INTERNATIONAL STANDARD



647

INTERNATIONAL ORGANIZATION FOR STANDARDIZATION • МЕЖДУНАРОДНАЯ ОРГАНИЗАЦИЯ ПО СТАНДАРТИЗАЦИИ • ORGANISATION INTERNATIONALE DE NORMALISATION

Brown coals and lignites — Determination of the yields of tar, water, gas and coke residue by low temperature distillation

Charbons bruns et lignites — Détermination des rendements en goudron, en eau, en gaz et en résidu de coke par distillation à basse température

First edition — 1974-11-01

UDC 662.643 : 662.613.4

Ref. No. ISO 647-1974 (E)

Descriptors : coal, lignite, chemical analysis, determination of content, tars, moisture content, coal gas, coke, distillation.

Price based on 6 pages

FOREWORD

ISO (the International Organization for Standardization) is a worldwide federation of national standards institutes (ISO Member Bodies). The work of developing International Standards is carried out through ISO Technical Committees. Every Member Body interested in a subject for which a Technical Committee has been set up has the right to be represented on that Committee. International organizations, governmental and non-governmental, in liaison with ISO, also take part in the work.

Draft International Standards adopted by the Technical Committees are circulated to the Member Bodies for approval before their acceptance as International Standards by the ISO Council.

Prior to 1972, the results of the work of the Technical Committees were published as ISO Recommendations; these documents are now in the process of being transformed into International Standards. As part of this process, Technical Committee ISO/TC 27 has reviewed ISO Recommendation R 647 and found it technically suitable for transformation. International Standard ISO 647 therefore replaces ISO Recommendation R 647-1968 to which it is technically identical.

ISO Recommendation R 647 was approved by the Member Bodies of the following countries :

Australia	Germany	Romania
Austria	India	South Africa, Rep. of
Belgium	Ireland	Spain
Brazil	Italy	Sweden
Canada	Japan	Switzerland
Chile	Korea, Rep. of	Turkey
Czechoslovakia	Netherlands	United Kingdom
Denmark	New Zealand	U.S.S.R.
Egypt, Arab Rep. of	Poland	Yugoslavia
France	Portugal	

No Member Body expressed disapproval of the Recommendation.

No Member Body disapproved the transformation of ISO/R 647 into an International Standard.

Brown coals and lignites – Determination of the yields of tar, water, gas and coke residue by low temperature distillation

0 INTRODUCTION

The yield of the distillation products by low temperature distillation, especially the yield of tar, forms the basis for the classification of brown coal and lignite for use in low temperature carbonization.

1 SCOPE AND FIELD OF APPLICATION

This International Standard specifies a method for the determination of the yields of tar, water, gas and coke residue obtained from brown coal and lignite by distillation to a final temperature of 520 °C.

2 REFERENCE

ISO/R 1015, *Determination of moisture in brown coals and lignites by the direct volumetric method.*

3 PRINCIPLE

The sample is heated in an aluminium retort to a temperature of 520 °C during a period of 80 min. The products of decomposition pass into a water-cooled receiver; the tar and water are condensed while gaseous products pass to atmosphere. The coke residue remaining in the retort is weighed. The receiver and its contents are also weighed and the mass of the water in it determined by entrainment with toluene or xylene: the mass of tar is obtained by difference.

The total water in the receiver includes the moisture in the coal as well as that from the decomposition of the coal. A separate determination of moisture in the coal, also by entrainment with toluene or xylene, is made so that the decomposition water can be calculated.

The percentage of gas (plus errors) is obtained by subtracting from 100 the sum of the percentages of coke residue, of tar and decomposition water. The results are reported on the "as analysed" and on the "dry" basis.

4 REAGENTS

4.1 Graphite paste, ground dry and made into a suitable paste with water or thick lubricating oil.

4.2 Xylene, boiling point 135 to 140 °C;

or **Toluene**, boiling point 110 °C.

5 APPARATUS

5.1 Retort, of aluminium, with the dimensions shown in figure 1; with the cover fitted, its capacity with the outlet tube shall be 170 ± 10 ml; the outlet tube shall be made of brass and its internal wall shall be clean and polished. A new assembly shall be heated at 520 °C for 20 min before use.

If, through wear, the upper edge of the conical portion of the cover is below the top surface of the retort, its free volume will be less than 160 ml and a new cover is required. The new oversize cover shall be ground so that when fitted the upper edge of the round portion is less than 7 mm above the top surface of the retort. This will ensure that the free volume of the retort does not exceed 180 ml.

5.2 Furnace, heated either electrically or by gas. For electrical heating, a resistance wire furnace or a silicon carbide rod furnace may be used.

5.3 Thermocouple and millivoltmeter, or a **nitrogen-filled mercury thermometer**, calibrated and capable of indicating the temperatures up to 550 °C.

NOTE – A new thermometer shall be aged and then calibrated before use and shall be rechecked at intervals of 1 month by comparing it with a standard thermometer in a manner approved by a national testing authority.

5.4 Receiver: round bottomed glass flask, capacity 750 ml, with conical ground joint and with either long or short neck depending on the method of connection to the retort (see figure 2), provided with a rubber or glass stopper.

5.5 Cooling bath, such that the distance between the receiver and the walls of the bath is not less than 20 mm. The water flow shall be adjusted to maintain a temperature of between 10 and 15 °C in the bath.

5.6 Distillation apparatus, suitable for the determination of moisture in brown coal or lignite, as specified in ISO/R 1015.

6 PREPARATION OF TEST SAMPLE

Spread the laboratory sample on a tray and allow it to attain approximate moisture equilibrium with the atmosphere. Carefully crush the sample so that at least 90 % passes through a sieve of 1 mm aperture whilst not more than 50 % passes through a sieve of 0,2 mm aperture. If the moisture content of the crushed sample is still greater than 20 %, further air-drying should be carried out to reduce the moisture content to between 10 and 20 %. The test sample may be stored in a hermetically sealed container. Alternatively, the sample may be kept for a period not longer than 1 week in a stoppered container filled to more than 80 % of its capacity.

NOTE – When samples are kept for longer than 1 week in containers which are not hermetically sealed or are not entirely filled, the loss of tar yield can be up to 0,5 % and in certain cases the loss may be considerably greater.

7 PROCEDURE

Weigh, to the nearest 0,05 g, about 50 g of the test sample and transfer it completely to the retort. Lightly smear the conical portion of the cover with the graphite paste, replace the cover and seal by rotating it. Determine the moisture content of the test sample at the same time by the method given in ISO/R 1015.

Weigh the receiver and stopper to the nearest 0,05 g and connect the receiver to the outlet tube of the retort by means of either a heat resistant stopper (see figure 2a) or a glass adapter tube (see figure 2b). In the latter case insert the brass outlet tube about 8 mm into the glass adapter tube and seal it to it by means of a short length of rubber tubing. Wind the joint with cotton, asbestos, linen, filter paper or similar material and cool by a stream of water while the retort is being heated. Place the retort in the furnace (see note 1) and the receiver in the cooling bath (see note 2) and ensure that the apparatus is gastight. Start the flow of water through the cooling bath and heat the retort according to the following schedule :

Time from start	Temperature
min	°C
10	220
20	310
30	380
40	440
50	480
60	505
70	520
80	520

Maintain the rate of heating within the limits shown in figure 3.

At the end of the above period stop the heating and remove the retort from the furnace with the receiver still connected; allow to stand for 10 min to enable the tar collected in the outlet tube to trickle down into the receiver. Disconnect the receiver from the retort and, if necessary, transfer the remaining tar from the outlet tube into the receiver with a small spatula (see note 3). Close the receiver and the outlet tube of the retort with stoppers and cool the retort to room temperature. Remove the coke residue carefully and weigh it to the nearest 0,05 g in a previously counterpoised weighing bottle.

Wipe off adhering water from the outside of the receiver and re-weigh to obtain the mass of the tar plus total water.

Add 200 ml of toluene or xylene to the receiver and determine the total water content by the method given in ISO/R 1015.

NOTES

- 1 It is necessary to pre-heat certain types of furnaces in order to reach 220 °C within 10 min of inserting the retort.
- 2 The receiver shall be immersed in the cooling bath as far as possible, but the rubber stopper or the ground joint shall not touch the water.
- 3 Only a very small residue of tar will be found in a clean smooth brass tube.

8 EXPRESSION OF RESULTS

The yields on the "as analysed" basis¹⁾ are given by the following formulae :

Coke residue, %

$$= \frac{m_4 \times 100}{m_0}$$

Tar, %

$$= \frac{(m_2 - m_1 - m_3) \times 100}{m_0}$$

Water (decomposition), %

$$= \frac{m_3 \times 100}{m_0} - M$$

Gas (plus errors), %

$$= 100 - (\text{coke} + \text{tar} + \text{total water})$$

$$= \frac{(m_0 + m_1 - m_2 - m_4) \times 100}{m_0}$$

where

m_0 is the mass, in grams, of sample;

m_1 is the mass, in grams, of empty receiver and stopper;

m_2 is the mass, in grams, of receiver and stopper, plus tar plus total water;

1) Calculation of the results to other bases is dealt with in ISO/R 1170.

m_3 is the mass, in grams, of total water determined by entrainment;

m_4 is the mass, in grams, of coke residue;

M is the moisture content, in percent, of the sample.

The yields on the "dry" basis are obtained by multiplying the above results by $\frac{100}{100 - M}$

The result, preferably the mean of duplicate determinations (see clause 9), should be reported to the nearest 0,1 %. Values for tar, coke residue, decomposition water and gas should be reported on the "as analysed" basis and on the "dry" basis. The tar content may also be calculated on the "dry, ash free" basis.

9 PRECISION OF THE METHOD

Test parameter (dry basis)	Maximum acceptable differences between results	
	Repeatability	Reproducibility
Tar	0,5 % absolute	0,7 % absolute
Water	0,4 % absolute	0,8 % absolute
Coke residue	0,7 % absolute	1,0 % absolute

9.1 Repeatability

The results of duplicate determinations, carried out at different times in the same laboratory, by the same operator, with the same apparatus, on representative portions taken from the same test sample, should not differ by more than the above values.

9.2 Reproducibility

The means of the results of duplicate determinations, carried out in each of two laboratories on test portions taken from the same laboratory sample, should not differ by more than the above values.

10 TEST REPORT

The test report shall include the following particulars :

- a) the reference of the method used;
- b) the results and the method of expression used;
- c) any unusual features noted during the determination;
- d) any operation not included in this International Standard, or regarded as optional.

Dimensions in millimetres

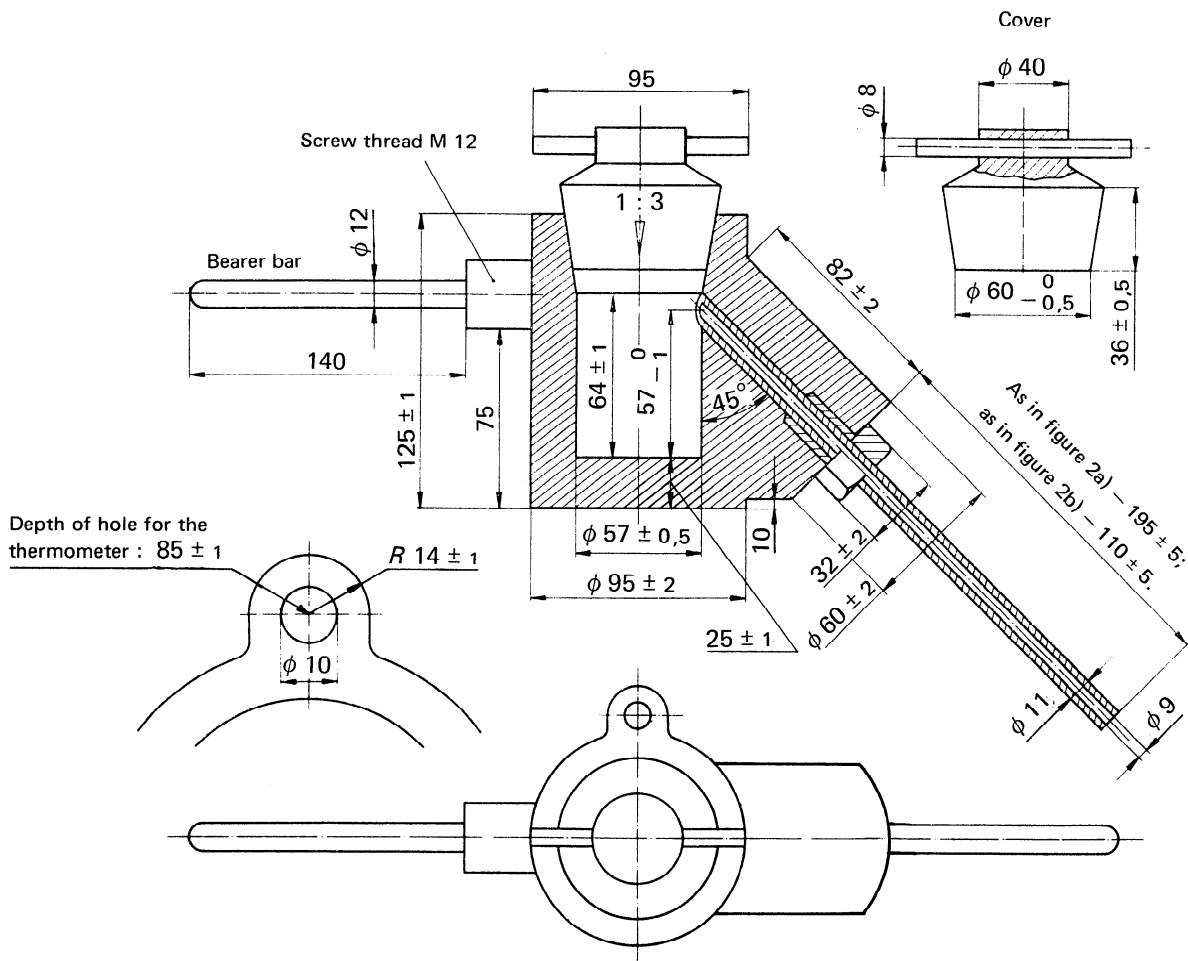

Materials : aluminium retort; aluminium content $> 99\%$
 volume of retort : 170 ± 10 ml
 outlet tube : brass.

FIGURE 1 - Retort

Dimensions in millimetres

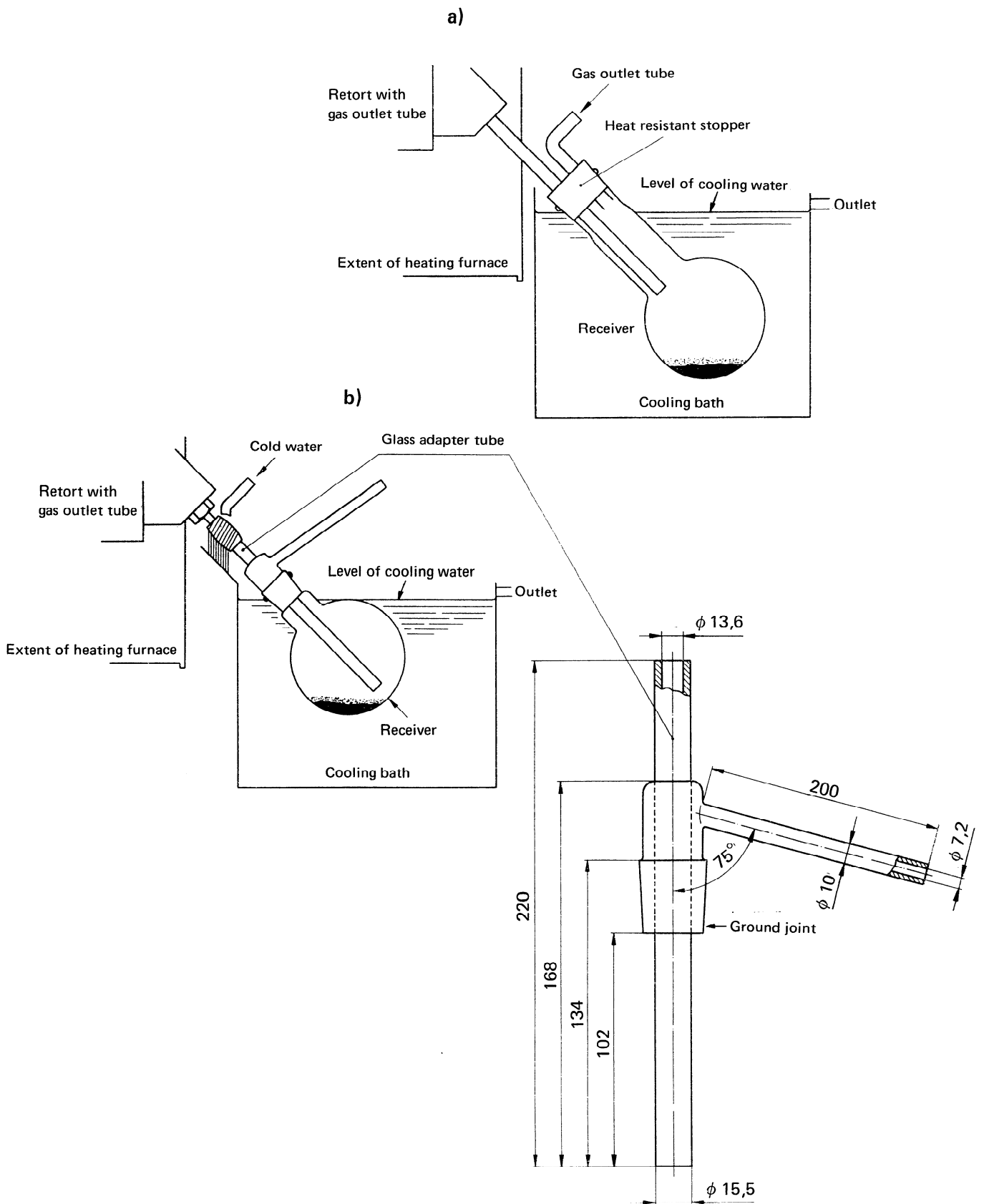

FIGURE 2 – Arrangement of the receiver in the cooling bath

Total time for low temperature distillation between 20 and 520 °C : 80 min

Effective time for low temperature distillation between 310 and 520 °C : 60 min

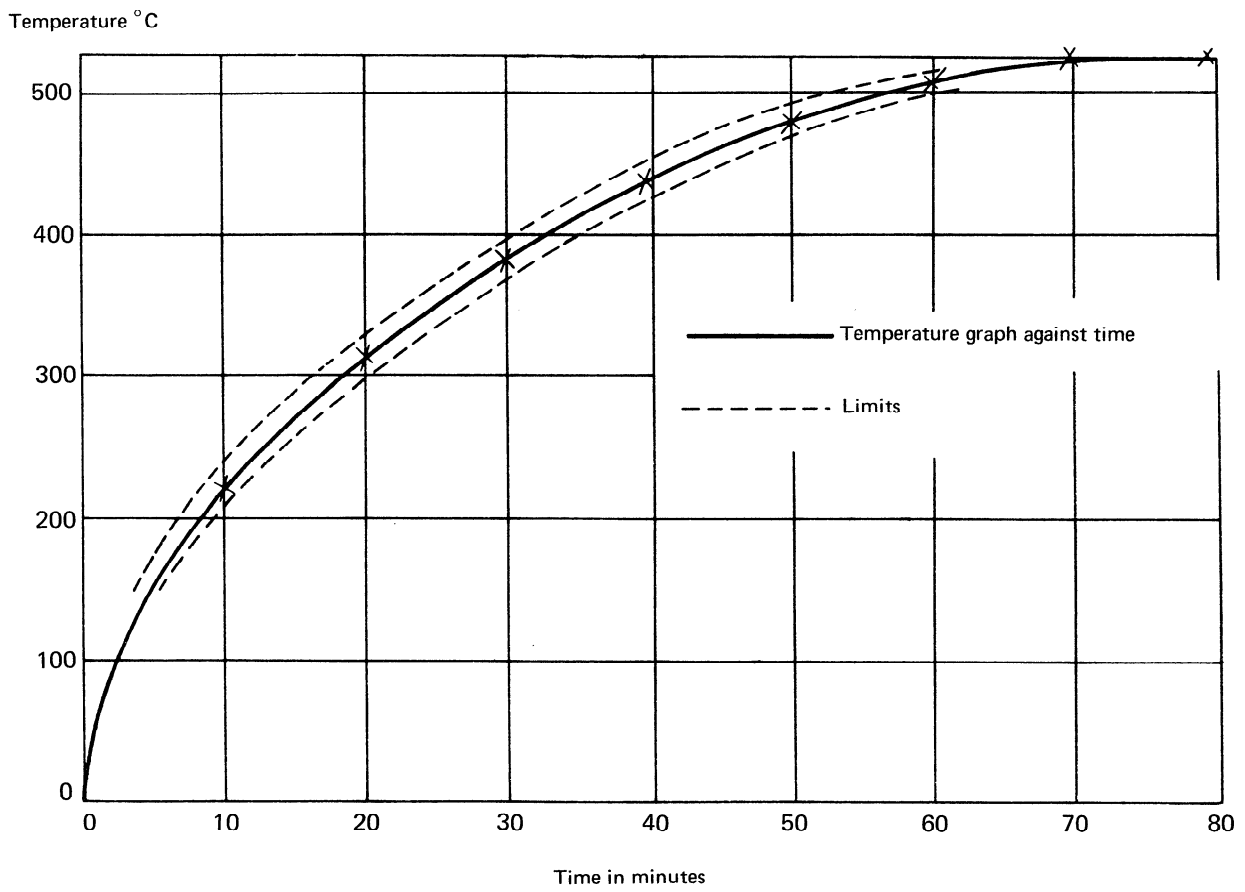

FIGURE 3 – Schedule of heating