



INTERNATIONAL STANDARD ISO 603-1:1999

ISO 603-2:1999
 ISO 603-3:1999
 ISO 603-4:1999
 ISO 603-5:1999
 ISO 603-6:1999
 ISO 603-7:1999
 ISO 603-8:1999
 ISO 603-9:1999
 ISO 603-10:1999
 ISO 603-11:1999
 ISO 603-12:1999
 ISO 603-13:1999
 ISO 603-14:1999
 ISO 603-15:1999
 ISO 603-16:1999

This material is reproduced from ISO documents under International Organization for Standardization (ISO) Copyright License Number HIS/CC/1996. Not for resale. No part of these ISO documents may be reproduced in any form, electronic retrieval system or otherwise, except as allowed in the copyright law of the country of use, or with the prior written consent of ISO (Case postale 56, 1211 Geneva 20, Switzerland, Fax +41 22 734 10 79), IHS or the ISO Licensor's members.

TECHNICAL CORRIGENDUM 1

Published 1999-11-15

INTERNATIONAL ORGANIZATION FOR STANDARDIZATION • МЕЖДУНАРОДНАЯ ОРГАНИЗАЦИЯ ПО СТАНДАРТИЗАЦИИ • ORGANISATION INTERNATIONALE DE NORMALISATION

Bonded abrasive products — Dimensions —

- Part 1: Grinding wheels for external cylindrical grinding between centres
- Part 2: Grinding wheels for centreless external cylindrical grinding
- Part 3: Grinding wheels for internal cylindrical grinding
- Part 4: Grinding wheels for surface grinding/peripheral grinding
- Part 5: Grinding wheels for surface grinding/face grinding
- Part 6: Grinding wheels for tool and tool room grinding
- Part 7: Grinding wheels for manually guided grinding
- Part 8: Grinding wheels for deburring and fettling/snagging
- Part 9: Grinding wheels for high-pressure grinding
- Part 10: Stones for honing and superfinishings
- Part 11: Hand finishing sticks
- Part 12: Grinding wheels for deburring and fettling on a straight grinder
- Part 13: Grinding wheels for deburring and fettling on a vertical grinder
- Part 14: Grinding wheels for deburring and fettling/snagging on an angle grinder
- Part 15: Grinding wheels for cutting-off on stationary or mobile cutting-off machines
- Part 16: Grinding wheels for cutting-off on hand held power tools

TECHNICAL CORRIGENDUM 1

Produits abrasifs agglomérés — Dimensions —

- Partie 1: Meules pour rectification cylindrique extérieure entre centres*
- Partie 2: Meules pour rectification cylindrique extérieure sans centres*
- Partie 3: Meules pour rectification cylindrique intérieure*
- Partie 4: Meules pour rectification plane/meulage tangentiel*
- Partie 5: Meules pour rectification plane/meulage latéral*
- Partie 6: Meules pour affûtage d'outils*
- Partie 7: Meules pour meulage à guidage manuel*
- Partie 8: Meules pour ébarbage et ébavurage*
- Partie 9: Meules pour meulage haute pression*
- Partie 10: Bâtons rodoirs et de super finition*
- Partie 11: Pierres à main*
- Partie 12: Meules pour ébarbage et ébavurage sur meuleuses portatives droites*
- Partie 13: Meules pour ébarbage et ébavurage sur meuleuses portatives à axe vertical*
- Partie 14: Meules pour ébarbage et ébavurage sur meuleuses portatives à renvoi d'angle*
- Partie 15: Meules pour tronçonnage sur machines fixes ou mobiles*
- Partie 16: Meules pour tronçonnage sur machines portatives*

RECTIFICATIF TECHNIQUE 1

ICS 25.100.70

Ref. No. ISO 603 (parts 1 to 16):1999/Cor.1:1999(E)

© ISO 1999 – All rights reserved

Printed in Switzerland

ISO 603 (parts 1 to 16):1999/Cor.1:1999(E)

Technical Corrigendum 1 to parts 1 to 16 of International Standard ISO 603 was prepared by Technical Committee ISO/TC 29, *Small tools*, Subcommittee SC 5, *Grinding wheels and abrasives*.

Page iii

Foreword

Paragraph 5, replace the reference to ISO 3290:1976 by ISO 3920:1976.

INTERNATIONAL STANDARD

ISO 603-4

First edition
1999-07-15

Bonded abrasive products — Dimensions —

Part 4: Grinding wheels for surface grinding/peripheral grinding

Produits abrasifs agglomérés — Dimensions —

Partie 4: Meules pour rectification plane/meulage tangentiel

This material is reproduced from ISO documents under International Organization for Standardization (ISO) Copyright License Number IHS/ICC/1996. Not for resale. No part of these ISO documents may be reproduced in any form, electronic retrieval system or otherwise, except as allowed in the copyright law of the country of use, or with the prior written consent of ISO (Case postale 56, 1211 Geneva 20, Switzerland, Fax +41 22 734 10 79), IHS or the ISO Licensor's members.



Reference number
ISO 603-4:1999(E)

Contents	Page
1 Scope	1
2 Normative references	2
3 Dimensions	3
3.1 Type 1: Straight grinding wheel	3
3.2 Type 5: Wheel recessed on one side	4
3.3 Type 7: Wheel recessed on both sides	6
3.4 Type 20: Wheel relieved on one side	8
3.5 Type 21: Wheel relieved on both sides	8
3.6 Type 22: Wheel relieved on one side and recessed on the other side	9
3.7 Type 23: Wheel relieved and recessed on one side	9
3.8 Type 24: Wheel relieved and recessed on one side and recessed on the other side	10
3.9 Type 25: Wheel relieved and recessed on one side and relieved on the other side	11
3.10 Type 26: Wheel relieved and recessed on both sides	12
3.11 Type 38: Hubbed wheel	13
3.12 Type 39: Double hubbed wheel	13
4 Designation	15
5 Specifications	15
5.1 Tolerances	15
5.2 Balancing	15
5.3 Marking	15
Bibliography	16

© ISO 1999

All rights reserved. Unless otherwise specified, no part of this publication may be reproduced or utilized in any form or by any means, electronic or mechanical, including photocopying and microfilm, without permission in writing from the publisher.

International Organization for Standardization
 Case postale 56 • CH-1211 Genève 20 • Switzerland
 Internet iso@iso.ch

Printed in Switzerland

Foreword

ISO (the International Organization for Standardization) is a worldwide federation of national standards bodies (ISO member bodies). The work of preparing International Standards is normally carried out through ISO technical committees. Each member body interested in a subject for which a technical committee has been established has the right to be represented on that committee. International organizations, governmental and non-governmental, in liaison with ISO, also take part in the work. ISO collaborates closely with the International Electrotechnical Commission (IEC) on all matters of electrotechnical standardization.

International Standards are drafted in accordance with the rules given in the ISO/IEC Directives, Part 3.

Draft International Standards adopted by the technical committees are circulated to the member bodies for voting. Publication as an International Standard requires approval by at least 75 % of the member bodies casting a vote.

International Standard ISO 603-4 was prepared by Technical Committee ISO/TC 29, *Small tools*, subcommittee SC 5, *Grinding wheels and abrasives*.

This first edition, together with ISO 603-1:1999 to ISO 603-3:1999 and ISO 603-5:1999 to ISO 603-16:1999, cancels and replaces ISO/R 603:1967, ISO 603-2:1981, ISO 1117:1975, ISO 2220:1972, ISO 2933:1974, ISO 3290:1976 and ISO 3921:1976 as a technical revision of these standards.

ISO 603 consists of the following parts, under the general title *Bonded abrasive products — Dimensions*:

- *Part 1: Grinding wheels for external cylindrical grinding between centres*
- *Part 2: Grinding wheels for centreless external cylindrical grinding*
- *Part 3: Grinding wheels for internal cylindrical grinding*
- *Part 4: Grinding wheels for surface grinding/peripheral grinding*
- *Part 5: Grinding wheels for surface grinding/face grinding*
- *Part 6: Grinding wheels for tool and tool room grinding*
- *Part 7: Grinding wheels for manually guided grinding*
- *Part 8: Grinding wheels for deburring and fettling/snagging*
- *Part 9: Grinding wheels for high-pressure grinding*
- *Part 10: Stones for honing and superfinishings*
- *Part 11: Hand finishing sticks*
- *Part 12: Grinding wheels for deburring and fettling on a straight grinder*
- *Part 13: Grinding wheels for deburring and fettling on a vertical grinder*
- *Part 14: Grinding wheels for deburring and fettling/snagging on an angle grinder*
- *Part 15: Grinding wheels for cutting-off on stationary or mobile cutting-off machines*
- *Part 16: Grinding wheels for cutting-off on hand held power tools*

Bonded abrasive products — Dimensions —

Part 4:

Grinding wheels for surface grinding/peripheral grinding

1 Scope

This part of ISO 603 specifies the nominal dimensions, in millimeters, of:

- Type 1: Straight grinding wheel
- Type 5: Wheel recessed on one side
- Type 7: Wheel recessed on both sides
- Type 20: Wheel relieved on one side
- Type 21: Wheel relieved on both sides
- Type 22: Wheel relieved on one side and recessed on the other side
- Type 23: Wheel relieved and recessed on one side
- Type 24: Wheel relieved and recessed on one side and recessed on the other side
- Type 25: Wheel relieved and recessed on one side and relieved on the other side
- Type 26: Wheel relieved and recessed on both sides.
- Type 38: Hubbed wheel
- Type 39: Double hubbed wheel

These bonded abrasive products are intended to be used for the grinding of plane surfaces where the workpiece is secured to a reciprocating table. The workpiece and the grinding wheel are mechanically guided.

2 Normative references

The following normative documents contain provisions which, through reference in this text, constitute provisions of this part of ISO 603. For dated references, subsequent amendments to, or revisions of, any of these publications do not apply. However, parties to agreements based on this part of ISO 603 are encouraged to investigate the possibility of applying the most recent editions of the normative documents indicated below. For undated references, the latest edition of the normative document referred to applies. Members of ISO and IEC maintain registers of currently valid International Standards.

ISO 525:1999, *Bonded abrasive products — General requirements.*

ISO 6103:1999, *Bonded abrasive products — Static balancing of grinding wheels — Testing.*

ISO 13942:—¹⁾, *Bonded abrasive products — Limit deviations and run-out tolerances.*

¹⁾ To be published.

3 Dimensions

3.1 Type 1: Straight grinding wheel

See Figure 1 and Table 1.

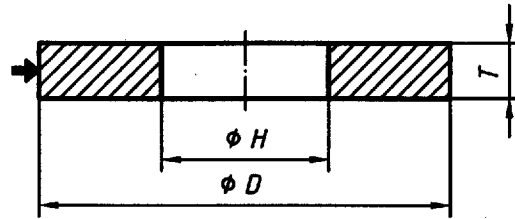

Figure 1 — Type 1

Table 1 — Dimensions of Type 1

<i>D</i>	<i>T</i>								<i>H</i>
	13	20	25	32	50	80	100	160	
150	X	—	—	—	—	—	—	—	32
180	X	—	—	—	—	—	—	—	
200	X	X	—	—	—	—	—	—	
	X	X	—	—	—	—	—	—	50,8
250	—	X	X	X	—	—	—	—	76,2
	—	X	X	X	—	—	—	—	
300	—	X	X	X	X	X	—	—	127
	—	X	X	X	X	X	—	—	76,2
350/356	—	—	—	X	X	X	—	—	127
	—	—	—	X	X	X	—	—	
400/406	—	—	—	X	X	X	X	—	203,2
500/508	—	—	—	—	X	X	X	X	
	600/610	—	—	—	—	X	X	X	304,8
750/762	—	—	—	—	X	X	X	X	

3.2 Type 5: Wheel recessed on one side

See Figure 2 and Table 2.

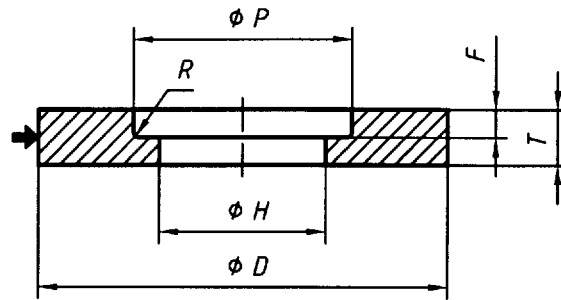

Figure 2 — Type 5

Table 2 — Dimensions of Type 5

<i>D</i>	<i>T</i>	<i>H</i>	<i>P</i>	<i>F</i>	<i>R_{max}</i>
150	25	32	80	10	1
	32			13	
180	25		100	10	32
	32			13	
200	25	32	110	10	
	32			13	
200	25	50,8	110	10	
	32			13	
250	32	50,8	150	13	
	40				
250	32	76,2	150	13	
	40				
300	40	76,2	150	13	
	50				
300	40	127	190	5	
	50				
350/356	40	127	215		13
	50				
400/406	40	127	215		13
	50				
450/457	63	127	215		25
	80				
450/457	40	203,2	280		13
	50				
	63				25
	80				
500/508	40	203,2	400		13
	50				
	63			25	
	80				
500/508	40	304,8	400	13	
	50				
	63			25	
	80				
600/610	63	203,2	400	13	
	80			25	
	100			50	
600/610	63	304,8	400	13	
	80			25	
	100			50	
750/762	63	304,8	400	13	
	80			25	
	100			50	
900/914	63	304,8	450	13	
	80			25	
	100			50	

3.3 Type 7: Wheel recessed on both sides

See Figure 3 and Table 3.

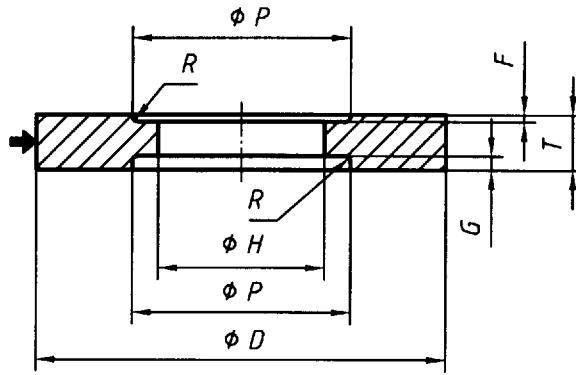

Figure 3 — Type 7

Table 3 — Dimensions of Type 7

<i>D</i>	<i>T</i>	<i>H</i>	<i>P</i>	<i>F</i>	<i>G</i>	<i>R</i> _{max}
300	40	76,2	150	6	6	3,2
	50			10	10	
300	40	127	190	6	6	5
	50		215	10	10	
350/356	40	127		215	10	
	50		215		10	
400/406	40	127		215	10	
	50		215		10	
450/457	63	127		215	13	
	80		215		13	
450/457	50	203,2		280	10	
	63		280		13	
	80				280	13
500/508	40	203,2	400	10		10
	50			400	13	13
	63					
	80					
500/508	40	304,8	400		10	10
	50			400	13	13
	63					
	80					
600/610	50	203,2	400		10	10
	63			400	13	13
	80					
	100				400	25
600/610	50	304,8	400			
	63			400	13	13
	80					
	100				400	25
750/762	80	304,8	400			
	100			400	25	
900/914	80	304,8	450			13
	100			450	25	

3.4 Type 20: Wheel relieved on one side

See Figure 4 and Table 4.

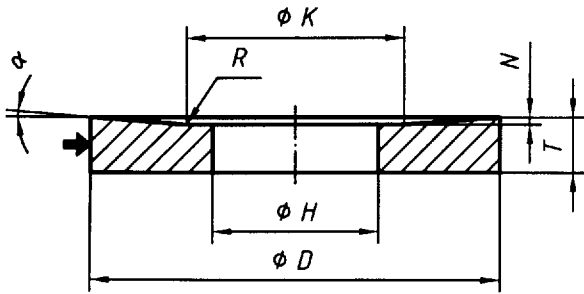

Figure 4 — Type 20

3.5 Type 21: Wheel relieved on both sides

See Figure 5 and Table 4.

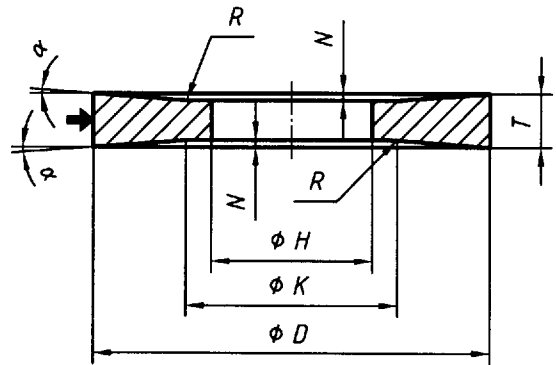

Figure 5 — Type 21

Table 4 — Dimensions of Type 20 and Type 21

D	T											H	K	N ^a		R _{max}
	13	16	20	25	32	40	50	63	80	100	125			$\alpha \approx 2^\circ$	$\alpha \approx 4^\circ$	
250	X	X	X	X	X	X	—	—	—	—	—	76,2	150	2	4	3,2
												127	190	1	2	5
300	X	X	X	X	X	X	X	—	—	—	—	76,2	150	3	5	3,2
												127	190	2	4	5
300/356	—	—	X	X	X	X	X	X	—	—	—	127	215	2	5	
400/406	—	—	X	X	X	X	X	X	X	—	—			3	7	
450/457	—	—	X	X	X	X	X	X	X	—	—	127	215	4	8	
												203,2	280	3	6	
500/508	—	—	X	X	X	X	X	X	X	—	—	203,2	400	2	4	8
												304,8				
600/610	—	—	—	—	X	X	X	X	X	X	—	203,2		4	7	
												304,8				
750/762	—	—	—	—	X	X	X	X	X	X	X	304,8	400	6	13	

^a The values N or 2N are taken less than or equal to half thickness T.

3.6 Type 22: Wheel relieved on one side and recessed on the other side

See Figure 6 and Table 5.

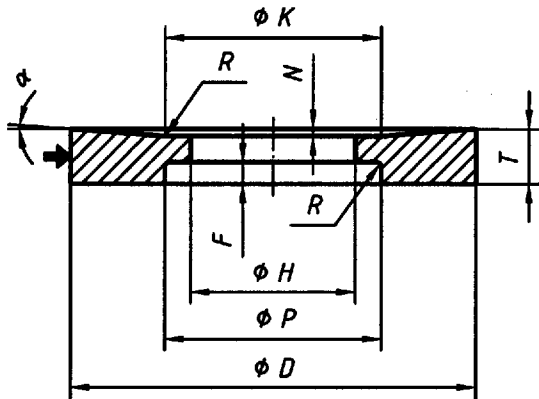

Figure 6 — Type 22

3.7 Type 23: Wheel relieved and recessed on one side

See Figure 7 and Table 5.

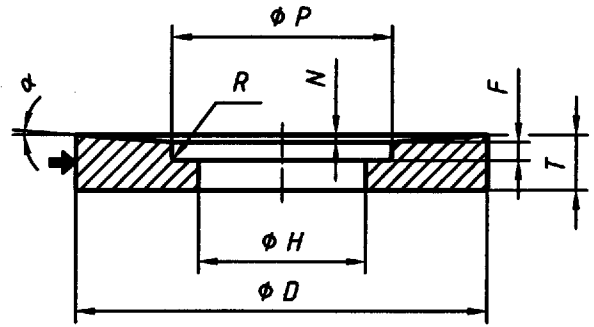

Figure 7 — Type 23

Table 5 — Dimensions of Type 22 and Type 23

D	T	H	$K=P$	F	N		R_{max}
					$\alpha = 2^\circ$	$\alpha = 4^\circ$	
300	40	76,2	150	13	3	5	3,2
	50				3	5	
300	40	127	190	13	2	4	5
	50				2	4	
350/356	40	127	215	13	2	5	
	50				2	5	
400/406	40	127	215	13	3	7	
	50				3	7	
450/457	63	127	215	25	4	8	
	80				4	8	
450/457	40	203,2	280	13	3	6	
	50				3	6	
	63			3	6		
	80			25	3	6	
500/508	40	203,2	400	13	2	4	
	50				2	4	
	63			2	4		
	80			25	2	4	
500/508	40	304,8	400	13	2	4	
	50				2	4	
	63			2	4		
	80			25	2	4	
600/610	63	203,2	400	13	4	7	
	80			25	4	7	
	100			40	4	7	
600/610	63	304,8	400	13	4	7	
	80			25	4	7	
	100			40	4	7	
750/762	63	304,8	400	13	6	13	
	80			25	6	13	
	100			40	6	—	

3.8 Type 24: Wheel relieved and recessed on one side and recessed on the other side

See Figure 8 and Table 6.

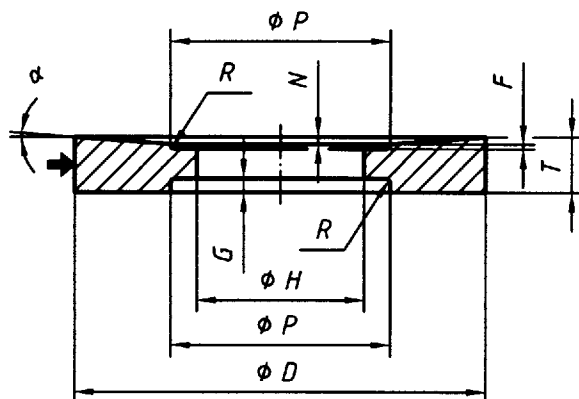

Figure 8 — Type 24

Table 6 — Dimensions of Type 24

D	T	H	P	F ^a	G ^a	N ^a		R _{max}
						$\alpha \approx 2^\circ$	$\alpha \approx 4^\circ$	
300	40	76,2	150	6	6	2	4	3,2
	50			10	10	3	—	
300	40	127	190	6	6	2	4	5
	50			10	10	3	—	
350/356	40	127	215	6	6	2	5	
	50					2	5	
400/406	40	127	215	6	6	3	7	
	50					3	7	
450/457	63	127	215	10	13	4	8	
	80			13		4	8	
450/457	50	203,2	280	6	6	3	6	
	63			13	3	6		
	80				3	6		
500/508	40	203,2	400	6	6	2	4	8
	50			13	2	4		
	63				2	4		
	80			2	4			
500/508	40	304,8	400	6	6	2	4	
	50			13	2	4		
	63				2	4		
	80			2	4			
600/610	50	203,2	400	6	6	4	7	
	63			13	4	—		
	80				4	7		
	100			25	4	7		
600/610	50	304,8	400	6	6	4	7	
	63			13	4	—		
	80				4	7		
	100			25	4	7		
750/762	80	304,8	400	13	13	6	13	
	100			25	6	—		

^a The values $N + F + G$ are taken less than or equal to half thickness T .

3.9 Type 25: Wheel relieved and recessed on one side and relieved on the other side

See Figure 9 and Table 7.

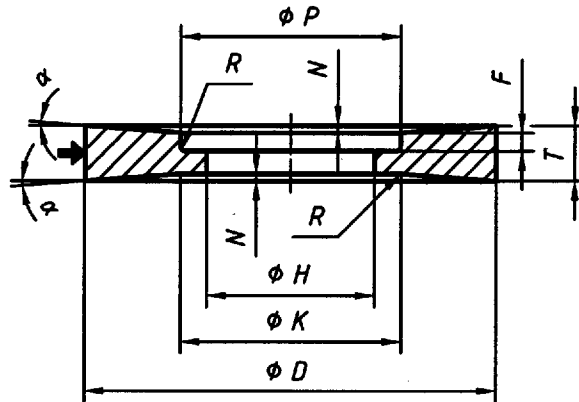

Figure 9 — Type 25

Table 7 — Dimensions of Type 25

D	T	H	K = P	F ^a	N ^a		R _{max}
					α	α	
300	40	76,2	150	13	3	—	3,2
	50				3	5	
300	40	127	190	13	2	—	5
	50				2	4	
350/356	40	127	215	13	2	—	
	50				2	5	
400/406	40	127	215	13	3	—	
	50				3	6	
450/457	63	127	215	13	4	8	
	80			25	4	7	
450/457	40	203,2	280	13	3	—	
	50				3	6	
	63			3	6		
	80			25	3	6	
500/508	40	203,2	400	13	2	—	
	50				2	4	
	63			2	4		
	80			25	2	4	
500/508	40	304,8	400	13	2	—	
	50				2	4	
	63			2	4		
	80			25	2	4	
600/610	63	203,2	400	13	4	7	
	80			25	4	7	
	100			40	4	—	
600/610	63	304,8	400	13	4	7	
	80			25	4	7	
	100			40	4	—	
750/762	63	304,8	400	13	6	—	
	80			25	6	—	
	100			40	5	—	

^a The values $2N + F$ are taken less than or equal to half thickness T .

3.10 Type 26: Wheel relieved and recessed on both sides

See Figure 10 and Table 8.

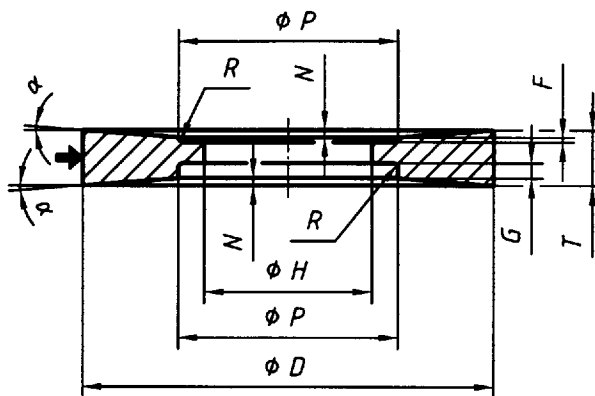

Figure 10 — Type 26

Table 8 — Dimensions of Type 26

D	T	H	P	F ^a	G ^a	N ^a		R _{max}
						α ≈ 2°	α ≈ 4°	
300	40	76,2	150	6	6	2	4	3,2
	50			10		2	—	
300	40	127	190	6	6	2	4	5
	50			10		2	—	
350/356	40	127	215	6	6	2	—	
	50			6		2	5	
400/406	40	127	215	6	6	3	—	
	50			6		3	6	
450/457	63	127	215	6	6	4	8	
	80			13		4	7	
450/457	50	203,2	280	6	6	3	6	
	63			13		3	6	
	80				13	3	6	
500/508	40	203,2	400	6	6	2	4	8
	50			13		2	4	
	63				13	2	—	
	80			13	2	4		
500/508	40	304,8	400	6	6	2	4	
	50			13		2	4	
	63				13	2	—	
	80			13	2	4		
600/610	50	203,2	400	6	6	4	—	
	63			13		—	—	
	80				13	4	—	
	100			25	4	—		
600/610	50	304,8	400	6	6	4	—	
	63			13		—	—	
	80				13	4	—	
	100			25	4	—		
750/762	80	304,8	400	13	13	6	—	
	100					25	6	—

^a The values 2N + F + G are taken less than or equal to half thickness T.

3.11 Type 38: Hubbed wheel

See Figure 11 and Table 9.

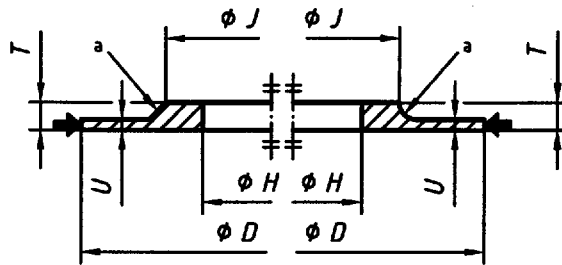

a Chamfer or radius left to the manufacturer's discretion.

Figure 11 — Type 38

3.12 Type 39: Double hubbed wheel

See Figure 12 and Table 9.

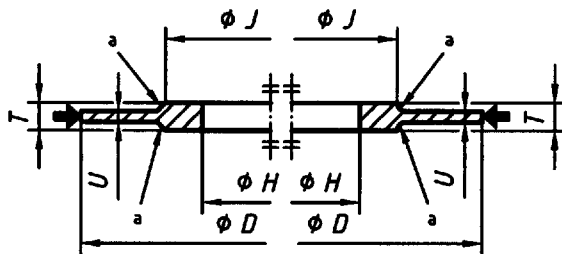

a Chamfer or radius left to the manufacturer's discretion.

Figure 12 — Type 39

Table 9 — Dimensions of Type 38 and Type 39

D	J	T	U								H
			3	5	8	13	20	25	32	40	
250	180	13	X	X	X	—	—	—	—	—	76,2
	190		—	—	—	—	—	—	—	—	127
250	180	20	—	—	—	X	—	—	—	—	76,2
	190		—	—	—	—	—	—	—	—	127
300	180	13	—	X	X	—	—	—	—	—	76,2
	220		—	—	—	—	—	—	—	—	127
300	180	20	—	—	—	X	—	—	—	—	76,2
	220		—	—	—	—	—	—	—	—	127
350/356	245	20	—	—	X	—	—	—	—	—	127
		25	—	—	—	X	X	—	—	—	
400/406	245	20	—	—	X	—	—	—	—	—	127
		25	—	—	—	X	—	—	—	—	
		32	—	—	—	—	X	—	—	—	
450/457	245	20	—	—	X	—	—	—	—	—	127
		25	—	—	—	X	—	—	—	—	
		32	—	—	—	—	X	X	—	—	
500/508	420	25	—	—	—	X	—	—	—	203,2	
500/508		32	—	—	—	—	X	X	—	304,8	
600/610	420	25	—	—	—	X	—	—	—	—	203,2
		32	—	—	—	—	X	—	—	—	304,8
600/610	420	40	—	—	—	—	—	X	X	—	203,2
600/610		32	—	—	—	—	—	—	—	—	304,8
750/762	420	32	—	—	—	X	X	—	—	—	304,8
		40	—	—	—	—	—	X	—	—	
		50	—	—	—	—	—	—	X	X	
900/914	550	32	—	—	—	X	X	—	—	—	304,8
		40	—	—	—	—	—	X	—	—	
		50	—	—	—	—	—	—	X	X	
1 060/1 067	550	32	—	—	—	X	X	—	—	—	304,8
		40	—	—	—	—	—	X	—	—	
		50	—	—	—	—	—	—	X	X	

4 Designation

A complete designation of a bonded abrasive product in accordance with this part of ISO 603 shall be consist of the following information:

- a) designation of the bonded abrasives, e.g. "Grinding wheel";
- b) reference of this part of ISO 603;
- c) type (shape);
- d) dimensions;
- e) specifications of an internal nature;
- f) the maximum operating speed.

} In accordance with ISO 525
and this part of ISO 603

EXAMPLE

A grinding wheel for surface grinding/peripheral grinding, Type 25, $D = 450$ mm, $K = 280$ mm, $T = 80$ mm, $N = 6$ mm, $H = 203,2$ mm, $P = 280$ mm, $F = 25$ mm, nature of abrasive A, grain size 46, grade I, structure 7, nature of bond V and a maximum operating speed of 32 m/s is designated as follows:

Grinding wheel ISO 603-4 - 25 - 450/280 × 80/6 × 203,2 - 280/25 - A 46 I7V - 32 m/s

5 Specifications

The specifications are left to the manufacture's discretion, see ISO 525.

5.1 Tolerances

Limit deviations and run-out tolerances in accordance with ISO 13942.

5.2 Balancing

Balancing is in accordance with ISO 6103.

5.3 Marking

Marking of bonded abrasive products is in accordance with ISO 525.

Bibliography

- [1] ISO 8486-1, *Bonded abrasives — Determination and designation of grain size distribution — Part 1: Macrogrits F4 to F220.*
- [2] ISO 8486-2, *Bonded abrasives — Determination and designation of grain size distribution — Part 2: Microgrits F230 to F1200.*

ICS 25.100.70

Price based on 16 pages
