

INTERNATIONAL STANDARD

ISO
603-11

First edition
1999-07-15

Bonded abrasive products — Dimensions —

Part 11: Hand finishing sticks

Produits abrasifs agglomérés — Dimensions —

Partie 11: Pierres à main



Reference number
ISO 603-11:1999(E)

Foreword

ISO (the International Organization for Standardization) is a worldwide federation of national standards bodies (ISO member bodies). The work of preparing International Standards is normally carried out through ISO technical committees. Each member body interested in a subject for which a technical committee has been established has the right to be represented on that committee. International organizations, governmental and non-governmental, in liaison with ISO, also take part in the work. ISO collaborates closely with the International Electrotechnical Commission (IEC) on all matters of electrotechnical standardization.

International Standards are drafted in accordance with the rules given in the ISO/IEC Directives, Part 3.

Draft International Standards adopted by the technical committees are circulated to the member bodies for voting. Publication as an International Standard requires approval by at least 75 % of the member bodies casting a vote.

International Standard ISO 603-11 was prepared by Technical Committee ISO/TC 29, *Small tools*, subcommittee SC 5, *Grinding wheels and abrasives*.

This first edition, together with ISO 603-1:1999 to ISO 603-10:1999 and ISO 603-12:1999 to ISO 603-16:1999, cancels and replaces ISO/R 603:1967, ISO 603-2:1981, ISO 1117:1975, ISO 2220:1972, ISO 2933:1974, ISO 3290:1976 and ISO 3921:1976 as a technical revision of these standards.

ISO 603 consists of the following parts, under the general title *Bonded abrasive products — Dimensions*:

- *Part 1: Grinding wheels for external cylindrical grinding between centres*
- *Part 2: Grinding wheels for centreless external cylindrical grinding*
- *Part 3: Grinding wheels for internal cylindrical grinding*
- *Part 4: Grinding wheels for surface grinding/peripheral grinding*
- *Part 5: Grinding wheels for surface grinding/face grinding*
- *Part 6: Grinding wheels for tool and tool room grinding*
- *Part 7: Grinding wheels for manually guided grinding*
- *Part 8: Grinding wheels for deburring and fettling/snagging*
- *Part 9: Grinding wheels for high-pressure grinding*
- *Part 10: Stones for honing and superfinishings*
- *Part 11: Hand finishing sticks*
- *Part 12: Grinding wheels for deburring and fettling on a straight grinder*

© ISO 1999

All rights reserved. Unless otherwise specified, no part of this publication may be reproduced or utilized in any form or by any means, electronic or mechanical, including photocopying and microfilm, without permission in writing from the publisher.

International Organization for Standardization
Case postale 56 • CH-1211 Genève 20 • Switzerland
Internet iso@iso.ch

Printed in Switzerland

- *Part 13: Grinding wheels for deburring and fettling on a vertical grinder*
- *Part 14: Grinding wheels for deburring and fettling/snagging on an angle grinder*
- *Part 15: Grinding wheels for cutting-off on stationary or mobile cutting-off machines*
- *Part 16: Grinding wheels for cutting-off on hand held power tools*

Bonded abrasive products — Dimensions —

Part 11: Hand finishing sticks

1 Scope

This part of ISO 603 specifies the nominal dimensions, in millimeters, of:

— Type 90: Hand finishing sticks

These bonded abrasive products are intended to be used for the generation and sharpening of any tool surface. The workpiece is held in the hand and the finishing stick is guided by hand.

2 Normative reference

The following normative document contains provisions which, through reference in this text, constitute provisions of this part of ISO 603. For dated references, subsequent amendments to, or revisions of, any of these publications do not apply. However, parties to agreements based on this part of ISO 603 are encouraged to investigate the possibility of applying the most recent edition of the normative document indicated below. For undated references, the latest edition of the normative document referred to applies. Members of ISO and IEC maintain registers of currently valid International Standards.

ISO 525:1999, *Bonded abrasive products — General requirements*.

3 Dimensions

See Table 1.

Table 1 — Dimensions of Type 9010, Type 9011, Type 9020, Type 9030 and Type 9040

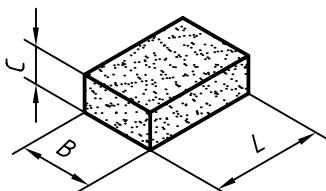
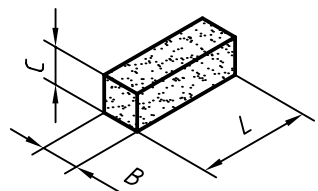
Type 9010			Type 9011	
				
<i>B</i>	<i>C</i>	<i>L</i>	<i>B = C</i>	<i>L</i>
6	3	100	6	100
10	5		10	—
13	6		—	—
25	13	150	—	150
16	8		13	
15	10		16	
20	10		20	150
50	25	200	25	—
20	15		20	200
30	20		—	—
50	25	—	—	—

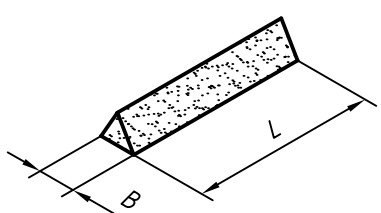
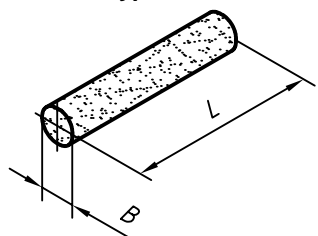
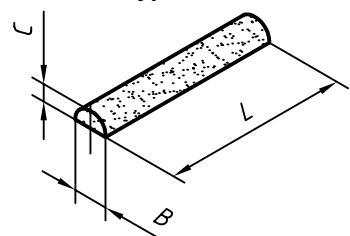
Type 9020		Type 9030		Type 9040	
					
<i>B</i>	<i>L</i>	<i>B</i>	<i>L</i>	<i>B = 2C</i>	<i>L</i>
6	100	6	100	6	100
8		8		8	
10		10		10	
13	150	10	150	10	150
10		13		13	
13		16		16	
16	200	20	200	20	200
20		25	250	25	250
25	250	—	—	—	—
30		—	—	—	—

4 Designation

A complete designation of a bonded abrasive product in accordance with this part of ISO 603 shall be consist of the following information:

- a) designation of the bonded abrasives, e.g. "Hand finishing stick";
- b) reference of this part of ISO 603;
- c) type (shape);
- d) dimensions;
- e) specifications of an internal nature;

} In accordance with ISO 525
and this part of ISO 603

EXAMPLE

A hand finishing stick for the generation of any tool surface, Type 9020, $B = 13$ mm, $L = 100$ mm, nature of abrasive C, grain size 150, bond V is designated as follows:

Hand finishing stick ISO 603-11 - 9020 - 13 × 100 - C 150V

5 Specifications

The specifications are left to the manufacture's discretion, see ISO 525.

5.1 Marking

Marking of bonded abrasive products is in accordance with ISO 525.

Bibliography

- [1] ISO 8486-1, *Bonded abrasives — Determination and designation of grain size distribution — Part 1: Macrogrits F4 to F220.*
- [2] ISO 8486-2, *Bonded abrasives — Determination and designation of grain size distribution — Part 2: Microgrits F230 to F1200.*

