**Conical fittings with 6 % (Luer) taper for
syringes, needles and certain other medical
equipment —**

**Part 2:
Lock fittings**

*Assemblages coniques à 6 % (Luer) des seringues et aiguilles
et de certains autres appareils à usage médical —*

Partie 2: Assemblages à verrouillage



Contents	Page
1 Scope	1
2 Normative references	1
3 Dimensions and tolerances	1
4 Requirements.....	6
5 Test methods	6

© ISO 1998

All rights reserved. Unless otherwise specified, no part of this publication may be reproduced or utilized in any form or by any means, electronic or mechanical, including photocopying and microfilm, without permission in writing from the publisher.

International Organization for Standardization
Case postale 56 • CH-1211 Genève 20 • Switzerland
Internet iso@iso.ch

Printed in Switzerland

Foreword

ISO (the International Organization for Standardization) is a worldwide federation of national standards bodies (ISO member bodies). The work of preparing International Standards is normally carried out through ISO technical committees. Each member body interested in a subject for which a technical committee has been established has the right to be represented on that committee. International organizations, governmental and non-governmental, in liaison with ISO, also take part in the work. ISO collaborates closely with the International Electrotechnical Commission (IEC) on all matters of electrotechnical standardization.

International Standards are drafted in accordance with the rules given in the ISO/IEC Directives, Part 3.

Draft International Standards adopted by the technical committees are circulated to the member bodies for voting. Publication as an International Standard requires approval by at least 75 % of the member bodies casting a vote.

International Standard ISO 594-2 was prepared by Technical Committee ISO/TC 84, *Medical devices for injections*.

This second edition cancels and replaces the first edition (ISO 594-2:1991), of which it constitutes a minor revision.

It corresponds to European Standard EN 1707:1996, prepared by Technical Committee CEN/TC 205, *Non-active medical devices*.

ISO 594 consists of the following parts, under the general title *Conical fittings with a 6 % (Luer) taper for syringes, needles and certain other medical equipment*:

- *Part 1: General specifications*
- *Part 2: Lock fittings*

Conical fittings with 6 % (Luer) taper for syringes, needles and certain other medical equipment — Part 2: Lock fittings

1 Scope

This part of ISO 594 specifies requirements for conical lock fittings with a 6 % (Luer) taper for use with hypodermic syringes and needles and with certain other apparatus for medical use, e.g. transfusion equipment.

The requirements apply to fittings made of rigid and of semi-rigid materials and include test methods, but exclude provision for more flexible or elastomeric materials.

NOTE 1 It is not practicable to define the characteristics of rigid or semi-rigid materials with precision, but glass and metal may be considered as typical rigid materials. In contrast many plastics materials may be regarded as semi-rigid.

NOTE 2 The Luer lock fitting was designed for use at pressures of the order of 300 kPa or lower. Its use in other applications may require consideration to establish its suitability.

2 Normative references

The following normative documents contain provisions which, through reference in this text, constitute provisions of this part of ISO 594. For dated references, subsequent amendments to, or revisions of, any of these publications do not apply. However, parties to agreements based on this part of ISO 594 are encouraged to investigate the possibility of applying the most recent editions of the normative documents indicated below. For undated references, the latest edition of the normative document referred to applies. Members of ISO and IEC maintain registers of currently valid International Standards.

ISO 468, *Surface roughness — Parameters, their values and general rules for specifying requirements.*

ISO 594-1:1986, *Conical fittings with a 6 % (Luer) taper for syringes, needles and certain other medical equipment — Part 1: General requirements.*

ISO 7886-1, *Sterile hypodermic syringes for single use — Part 1: Syringes for manual use.*

3 Dimensions and tolerances

3.1 Male and female 6 % (Luer) conical fittings

The dimensions and tolerances for the male and female fittings specified in ISO 594-1 apply to the relevant conical part of the fitting described in clause 4 of this part of ISO 594.

3.2 Male and female 6 % (Luer) conical lock fittings

3.2.1 Rigid materials

The dimensions of male and female lock fittings made of rigid materials shall be as shown in Figures 1 to 4 and as given in Table 1.

3.2.2 Semi-rigid materials

For fittings made using semi-rigid materials, because of their nature it is not possible to specify the fittings dimensions accurately. Design and dimensions of fittings made of these materials may vary from those designated in Figures 1 and 4 and given in Table 1. However, the fittings shall meet the specified performance requirements when fitted to reference fittings as specified in 5.1.

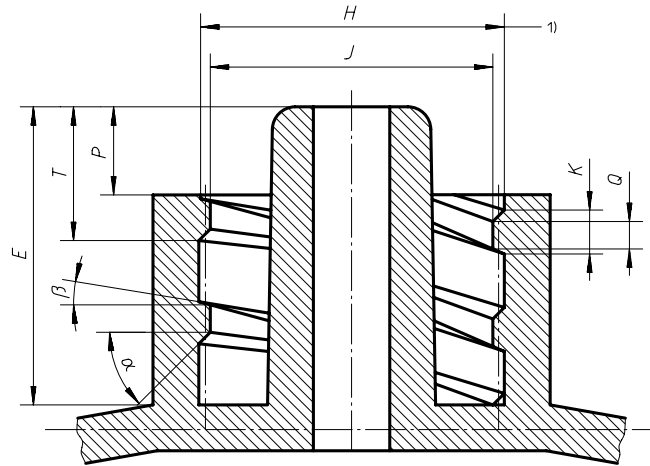

1) Double-start, right-hand thread of 2,5 mm pitch.

Figure 1 — Male 6 % (Luer) conical lock fitting with permanently connected internally threaded collar

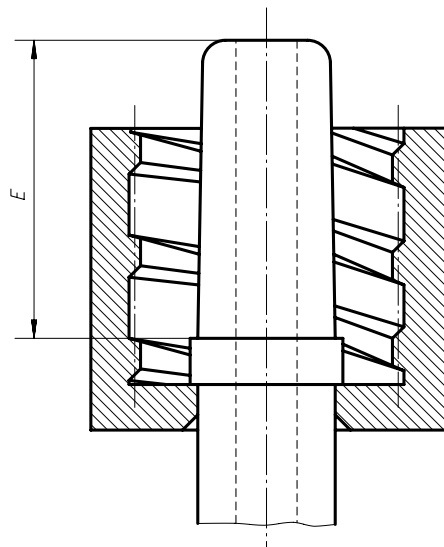

NOTE For other dimensions, see Figure 1.

Figure 2 — Male 6 % (Luer) conical lock fitting with rotatable internally threaded collar

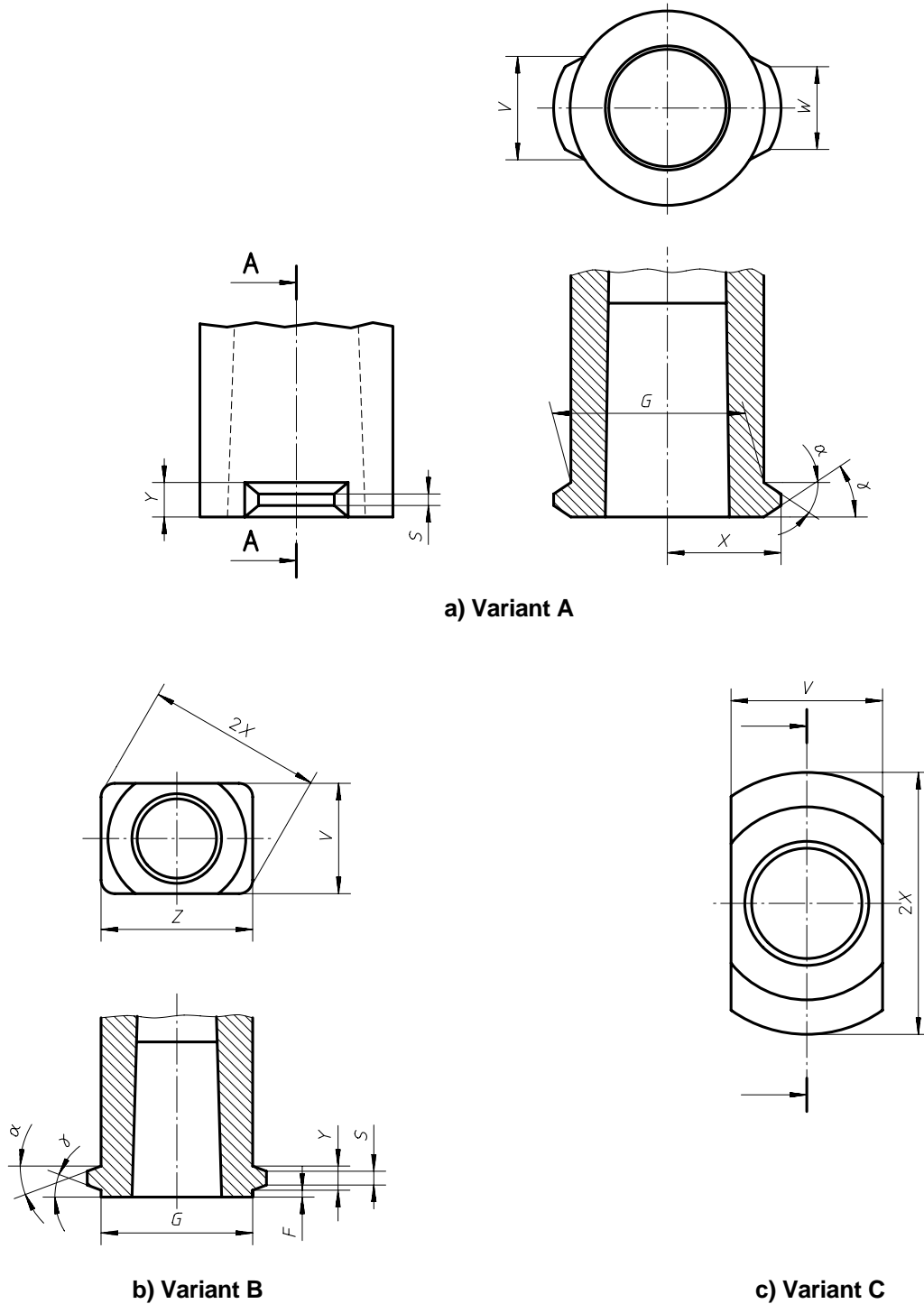

a) Variant A

b) Variant B

c) Variant C

NOTE 1 If a female 6 % (Luer) conical lock fitting has lugs in a plane inclined to the axis of fitting, the lugs should form a part of the thread form shown in Figure 4. In this case, 'V' does not apply.

NOTE 2 Variants B and C are intended to be used for the design of rigid fittings only.

NOTE 3 To ensure compatibility with existing rigid fittings, a maximum $K = 0,8$ mm is preferred.

Figure 3 — Female 6 % (Luer) conical lock fittings with lugs in a plane at right angles to axis of fitting

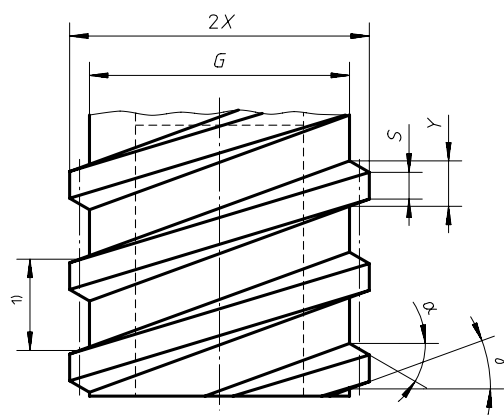

1) Pitch.

NOTE For other dimensions, see Figure 3.

Figure 4 — Female 6 % (Luer) lock conical fitting with external thread

Table 1 — Dimensions of 6 % (Luer) rigid conical lock fittings

Dimensions in millimetres

Symbol	Designation	Dimensions	
		Figures 1, 2, 3a) and 4	Figures 3b) and 3c)
α	Angle of thread or lug bearing surface against separation with the plane perpendicular to the axis of lock fitting	$25^{\circ} +5^{\circ}$ 0°	$25^{\circ} +5^{\circ}$ 0°
β	Minimum angle of internal thread non-bearing surface against separation with the plane perpendicular to the axis of lock fitting	25°	—
γ	Minimum angle of external thread or lug non-bearing surface against separation with the plane perpendicular to the axis of the lock fitting	0°	0°
E	Minimum length of male lock fitting	7,5	—
F	Nominal distance from the face of the fitting to the base of the lug	—	0,20
G	Maximum outside diameter of female lock fitting at base of lugs or maximum inside diameter of external thread. This diameter shall not be increased for a distance from the hub face of 5,5 mm	6,73	5,7
H	Root diameter of the thread of male lock fitting	$8,0 \pm 0,1$	—
J	Crest diameter of the thread of male lock fitting	$7,0 \pm 0,2$	—
K	Maximum thread width of male lock fitting at root	1	—
P	Minimum projection of nozzle from collar	2,1	—
Q	Minimum thread crest width of male lock fittings	0,3	—
S	Lug crest width or thread crest width of female lock fitting with lugs or external thread	0,3 min.	0,27 max.
T	Maximum distance from tip of male lock fitting to the bottom of first complete thread form of the internal thread	3,2	—
V	Maximum chord length at base of lug in a plane at right angles to axis of fitting only, to be measured on a chord of a circle the diameter of which is J min. (7,0 mm)	3,5	5,0
W	Minimum chord length at extremity of lug in a plane at right angles to axis of fitting only (W shall not be greater than V)	2,71	—
X	Distance from axis of female lock fitting to extremity of lug	—	—
$2X$	Outside diameter across the lugs or external thread	$7,83 \begin{smallmatrix} 0 \\ -0,1 \end{smallmatrix}$	$7,80 \begin{smallmatrix} 0 \\ -0,1 \end{smallmatrix}$
Y	Maximum width of base of lug (axial) or thread at base, of female lock fitting to be measured at a point corresponding to an outside diameter equal to G (6,73 max.)	1,2	1,30
Z	Width across the lugs at external thread	—	$6,50 \begin{smallmatrix} 0 \\ -0,1 \end{smallmatrix}$
Pitch	Nominal pitch of double-start, right-hand thread of female lock fitting - 5 mm lead	2,5	—

4 Requirements

4.1 Gauging

When tested with the appropriate gauge, the conical part of the lock fitting shall comply with ISO 594-1.

4.2 Leakage

4.2.1 Liquid leakage

When the fitting is tested in accordance with 5.2, there shall be no leakage sufficient to form a falling drop.

4.2.2 Air leakage

When the fitting is tested in accordance with 5.3, there shall be no signs of continued formation of air bubbles. Bubbles formed during the first 5 s shall be disregarded.

4.3 Separation force

When the fitting is tested in accordance with 5.4, it shall remain attached to the reference fitting.

4.4 Unscrewing torque

When the fitting is tested in accordance with 5.5, it shall remain attached to the reference fitting.

4.5 Ease of assembly

When the fitting under test is mounted by hand on the appropriate reference fitting in accordance with 5.6, the following criterion, as appropriate, shall be satisfied:

- a) rigid fittings: no resistance shall be observed until the taper of the fitting under test and the reference fitting fit together securely;
- b) semi-rigid fittings: a satisfactory fit shall be achieved by applying an axial force not exceeding 20 N while applying a torque not exceeding 0,08 N·m.

4.6 Resistance to overriding

When the fitting is tested in accordance with 5.7, the reference fitting shall not override the threads or lugs of the fitting under test.

4.7 Stress cracking

When the fitting is tested in accordance with 5.8, there shall be no evidence of stress cracking of the fitting.

NOTE Materials used for fittings should be resistant to stress cracking in environments likely to be encountered in use (e.g. when in contact with solvents, surface-active agents, etc.).

5 Test methods

5.1 General

Tests shall be carried out using the appropriate reference fitting; reference fittings are shown in Figures 5 to 8. The reference fittings shall be manufactured from hardened corrosion-resistant materials with a surface roughness value, R_a , not exceeding 0,8 μm (in accordance with ISO 468) on critical surfaces. The dimensions of the conical part of these reference fittings shall be in accordance with those specified in Figures 4 and 5 of ISO 594-1:1986.

5.2 Liquid leakage from fitting assembly under pressure

5.2.1 Connect the fitting to be tested to a reference fitting, the dimensions of which are in accordance with those shown in Figure 5 or Figure 7, as appropriate. Dry both fittings. Assemble the fittings by applying an axial force not exceeding 27,5 N while applying a torque not exceeding 0,12 N·m.

5.2.2 Introduce water into the assembly and expel the air. Ensure that the outside of the fitting assembly is dry.

5.2.3 With the axis of the lock fitting horizontal, seal the assembly outlet and bring the internal water pressure to an effective pressure of 300 kPa to 330 kPa and maintain the pressure for 30 s.

If the intended use is on a device employing higher pressure, then this shall be taken into consideration during testing.

5.3 Air leakage into fitting assembly during aspiration

5.3.1 General

Other validated test methods (e.g. methods involving automatic testing) may be used if good correlation is shown with the reference test given in 5.3.2 or 5.3.3. In cases of dispute, the methods given in this part of ISO 594 shall be the referee methods.

5.3.2 Male fitting

5.3.2.1 Connect the male fitting to a female reference fitting, the dimensions of which are in accordance with those shown in Figure 5. Dry both fittings. Connect the male fitting to the female reference fitting by applying an axial force not exceeding 27,5 N while applying a torque not exceeding 0,12 N·m.

5.3.2.2 Connect the female reference fitting, via a leakproof joint of minimal volume, to a syringe which has passed the test in accordance with ISO 7886-1 for leakage past the piston during aspiration.

5.3.2.3 Draw into the syringe, through the assembly, a volume of recently boiled and cooled water exceeding 25 % of the graduated capacity of the syringe. Avoid wetting the outside of the assembly.

5.3.2.4 Expel the air except for a small residual air bubble and adjust the volume of water in the syringe to 25 % of the graduated capacity.

5.3.2.5 Occlude the device below the fitting assembly. With the nozzle of the syringe pointing downwards, withdraw the plunger to nominal capacity and hold for 15 s.

5.3.3 Female fitting

Follow the same test procedure as specified in 5.3.2, but using a syringe with a male reference fitting, the dimensions of which are in accordance with those shown in Figure 7, to mate with the female fitting under test.

5.4 Separation force of fitting assembly

5.4.1 Connect the fitting to be tested to a reference fitting, the dimensions of which are in accordance with those shown in Figure 6 or Figure 8 as appropriate; follow the same assembly procedure as specified in 5.2.1 for liquid leakage testing.

5.4.2 Apply an axial force progressively up to 35 N in a direction away from the test fixture. Apply the force at a rate of approximately 10 N/s and maintain it for not less than 10 s. Do not apply any force in other directions or any inertial loading.

5.5 Unscrewing torque of fitting assembly

5.5.1 Follow the same assembly procedure as specified in 5.4.1.

5.5.2 Apply an unscrewing torque of $(0,02 \begin{smallmatrix} 0 \\ -0,002 \end{smallmatrix})$ N·m to the assembly and maintain for not less than 10 s. Do not apply any force in other directions or any inertial loading.

5.6 Ease of assembly

Mount by hand the fitting under test on the male or female reference fitting (see Figures 5 and 7) as appropriate. For rigid fittings, assemble the fittings securely; for semi-rigid fittings, apply an axial force not exceeding 20 N together with a torque not exceeding 0,08 N·m.

5.7 Resistance to overriding

Follow the same procedure as specified in 5.2.1 for liquid leakage testing, but using the appropriate reference fitting shown in Figure 6 or Figure 8; apply a torque not less than 0,15 N·m to the fitting under test and hold constant for 5 s.

5.8 Stress cracking

5.8.1 Connect the fitting to be tested to a reference fitting, the dimensions of which are in accordance with those shown in Figures 5 and 7, as appropriate. Dry both fittings. Assemble the fittings by applying an axial force not less than 27,5 N for 5 s while applying a torque not less than 0,12 N·m.

5.8.2 Allow the fittings to remain assembled for (48 ± 1) h at (20 ± 5) °C.

NOTE The use of (27 ± 5) °C is accepted as an alternative to (20 ± 5) °C for tropical countries.

Dimensions in millimetres

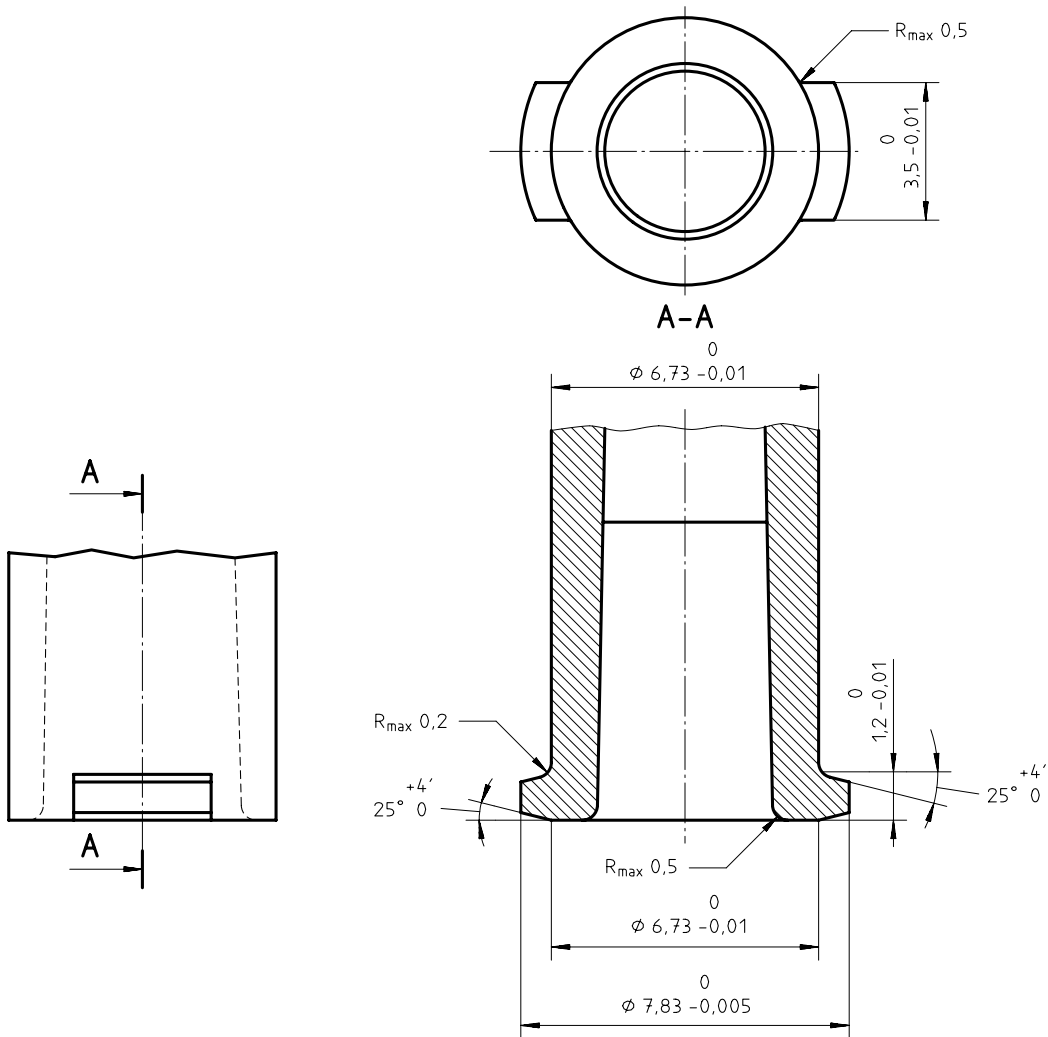

NOTE All outside edges of lug or thread form shall have a radius between 0,15 mm and 0,2 mm (unless otherwise specified).

Figure 5 — Female reference conical fitting for testing male 6 % (Luer) lock fittings for leakage, ease of assembly, unscrewing torque and stress cracking (see 5.2, 5.3, 5.5, 5.6 and 5.8)

Dimensions in millimetres

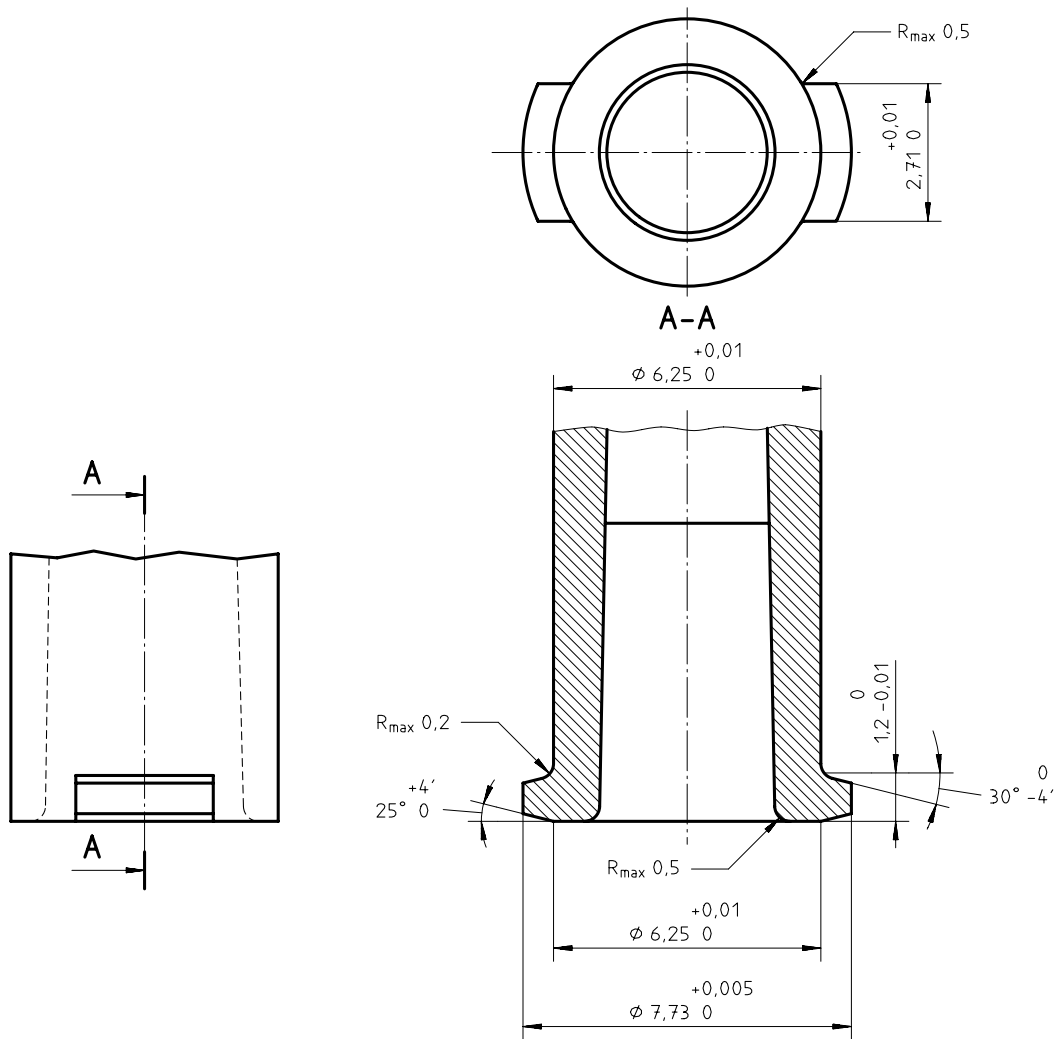

NOTE All outside edges of lug or thread form shall have a radius between 0,15 mm and 0,2 mm (unless otherwise specified).

Figure 6 — Female reference conical fitting for testing male 6 % (Luer) lock fittings for separation force and resistance to overriding (see 5.4 and 5.7)

Dimensions in millimetres

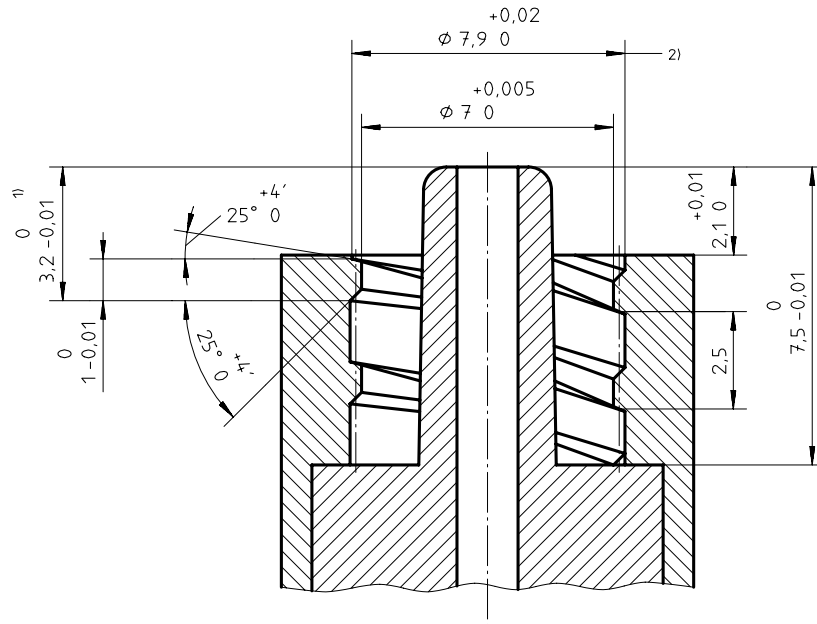

- 1) Maximum distance from tip of male lock fitting to the bottom of first complete thread form of the internal thread (see *T* in Table 1).
- 2) Double-start, right-hand thread of 2,5 mm pitch.

Figure 7 — Male reference conical fitting for testing female 6 % (Luer) lock fittings for leakage, ease of assembly, unscrewing torque and stress cracking (see 5.2, 5.3, 5.5, 5.6 and 5.8)

Dimensions in millimetres

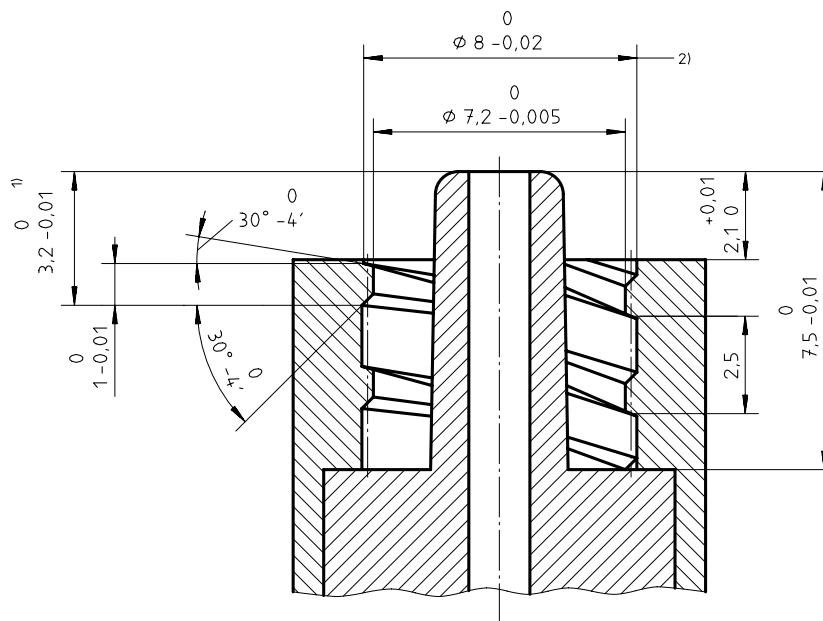

- 1) Maximum distance from tip of male lock fitting to the first complete thread form of the internal thread (see *T* in Table 1).
- 2) Double-start, right-hand thread of 2,5 mm pitch.

Figure 8 — Male reference conical fitting for testing female 6 % (Luer) lock fittings for separation force and resistance to overriding (see 5.4 and 5.7)

ICS 11.040.20

Descriptors: medical equipment, syringes, hypodermic needles, fittings, conical clamping connections, locking devices, specifications, dimensions, tests, pressure tests.

Price based on 11 pages
