

C-36-25

INTERNATIONAL STANDARD ISO 572-1976 (E)/ERRATUM



Published 1976-10-15

INTERNATIONAL ORGANIZATION FOR STANDARDIZATION • МЕЖДУНАРОДНАЯ ОРГАНИЗАЦИЯ ПО СТАНДАРТИЗАЦИИ • ORGANISATION INTERNATIONALE DE NORMALISATION

Textile machinery and accessories — Shuttles for pirn changing automatic looms — Dimensions**ERRATUM***Page 2*In the heading of the table, replace *D* by *d*.

INTERNATIONAL STANDARD**572**

INTERNATIONAL ORGANIZATION FOR STANDARDIZATION · МЕЖДУНАРОДНАЯ ОРГАНИЗАЦИЯ ПО СТАНДАРТИЗАЦИИ · ORGANISATION INTERNATIONALE DE NORMALISATION

Textile machinery and accessories — Shuttles for pirn changing automatic looms — Dimensions*Matériel pour l'industrie textile — Navettes pour changement automatique de canettes — Dimensions*

First edition — 1976-08-01

UDC 677.058.4

Ref. No. ISO 572-1976 (E)

Descriptors : textile machinery, automatic looms, shuttles, specification, dimensions, nomenclature, definitions.

Price based on 2 pages

FOREWORD

ISO (the International Organization for Standardization) is a worldwide federation of national standards institutes (ISO Member Bodies). The work of developing International Standards is carried out through ISO Technical Committees. Every Member Body interested in a subject for which a Technical Committee has been set up has the right to be represented on that Committee. International organizations, governmental and non-governmental, in liaison with ISO, also take part in the work.

Draft International Standards adopted by the Technical Committees are circulated to the Member Bodies for approval before their acceptance as International Standards by the ISO Council.

Prior to 1972, the results of the work of the Technical Committees were published as ISO Recommendations; these documents are now in the process of being transformed into International Standards. As part of this process, Technical Committee ISO/TC 72 has reviewed ISO Recommendation R 572 and found it technically suitable for transformation. International Standard ISO 572 therefore replaces ISO Recommendation R 572-1967 to which it is technically identical.

ISO Recommendation R 572 was approved by the Member Bodies of the following countries :

Chile	Greece	Switzerland
Czechoslovakia	Korea, Rep. of	Turkey
Egypt, Arab Rep. of	Netherlands	United Kingdom
France	Poland	
Germany	Spain	

The Member Bodies of the following countries expressed disapproval of the Recommendation on technical grounds :

India
U.S.S.R.

The Member Bodies of the following countries disapproved the transformation of ISO/R 572 in an International Standard :

Belgium
Germany
India
Poland

Textile machinery and accessories — Shuttles for pirn changing automatic looms — Dimensions

1 SCOPE AND FIELD OF APPLICATION

This International Standard specifies the dimensions of 90° shuttles for pirn changing automatic looms used in the textile industry.

2 REFERENCE

ISO 143, *Textile machinery and accessories — Weft pirns for automatic looms*.¹⁾

¹⁾ At present at the stage of draft. (Revision of ISO/R 143-1960.)

3 DIMENSIONS

Dimensions in millimetres

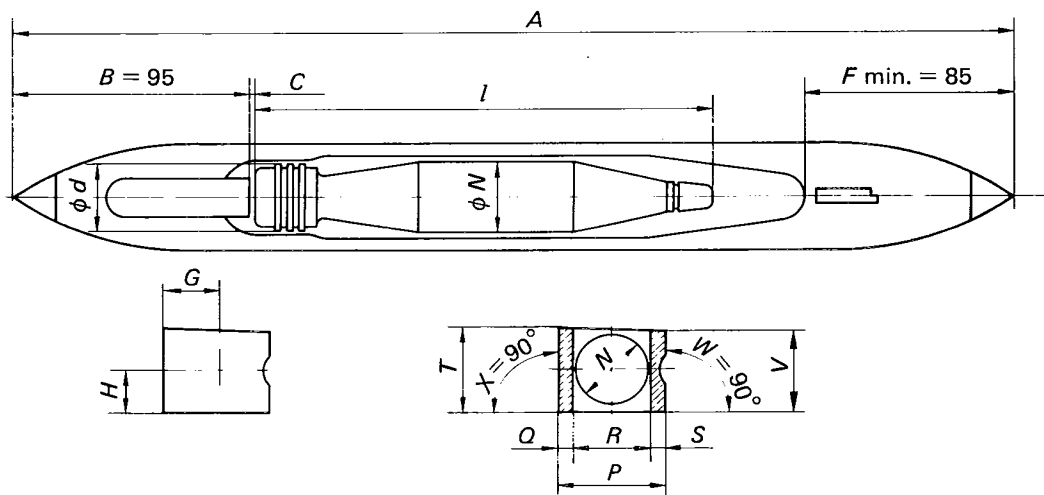

- A = overall length of shuttle
- B = distance from tip of shuttle at jaw end to end of guide or cover
- C = clearance between guide or cover and pin base as maximum and minimum
- d = diameter of pin over rings (ISO 143)
- F = distance from tip of shuttle at eye end to nearest point of cut out at base of shuttle
- G = distance from back wall of shuttle to centre of tip
- H = distance from base of shuttle to centre of tip
- l = length of pin (ISO 143)
- N = maximum diameter of full pin (according to pin type and shuttle type)
- P = width of shuttle at base
- Q = thickness of back wall of shuttle
- R = width between back and front walls of shuttle
- S = thickness of front wall of shuttle
- T = height of shuttle at back wall
- V = height of shuttle at back wall
- W = angle of front wall with base
- X = angle of back wall with base

Dimensions in millimetres

P × T		A	D × l (ISO 143)
Narrow series	Wide series		
42 × 29	46 × 29	385	24,4 × 172
46 × 32	50 × 32	385	27,2 × 172
46 × 32	50 × 32	410	27,2 × 190
46 × 35	50 × 35	425	30,3 × 200
46 × 35	50 × 35	450	30,3 × 220
52 × 39	—	450	34,0 × 220
—	55 × 42	450	34,0 × 220
—	55 × 42	475	34,0 × 240
60 × 46	—	475	34,0 × 240