

Fifth edition
2014-07-15

Corrected version
2014-09-15

**Rolling bearings — Radial bearings
— Geometrical product specifications
(GPS) and tolerance values**

*Roulements — Roulements radiaux — Spécification géométrique des
produits (GPS) et valeurs de tolérance*



Reference number
ISO 492:2014(E)

© ISO 2014



COPYRIGHT PROTECTED DOCUMENT

© ISO 2014

All rights reserved. Unless otherwise specified, no part of this publication may be reproduced or utilized otherwise in any form or by any means, electronic or mechanical, including photocopying, or posting on the internet or an intranet, without prior written permission. Permission can be requested from either ISO at the address below or ISO's member body in the country of the requester.

ISO copyright office
Case postale 56 • CH-1211 Geneva 20
Tel. + 41 22 749 01 11
Fax + 41 22 749 09 47
E-mail copyright@iso.org
Web www.iso.org

Published in Switzerland

Contents

	Page
Foreword	iv
Introduction	v
1 Scope	1
2 Normative references	1
3 Terms and definitions	1
4 Symbols	1
5 Limit deviations and tolerance values	17
5.1 General.....	17
5.2 Radial bearings except tapered roller bearings.....	18
5.3 Radial tapered roller bearings.....	28
5.4 Radial bearings, outer ring flanges.....	41
5.5 Basically tapered bores, tapers 1:12 and 1:30.....	42
Annex A (informative) Symbols and terms as given in ISO 492:2002 in relation to descriptions given in this International Standard	44
Annex B (informative) Example of drawing indications of characteristics with specification for radial bearings	48
Annex C (informative) Illustration of ISO 1132-1 and ISO 14405-1 terms and definitions	50
Annex D (informative) Description with illustrations for specification modifiers of linear sizes	57
Bibliography	66

Foreword

ISO (the International Organization for Standardization) is a worldwide federation of national standards bodies (ISO member bodies). The work of preparing International Standards is normally carried out through ISO technical committees. Each member body interested in a subject for which a technical committee has been established has the right to be represented on that committee. International organizations, governmental and non-governmental, in liaison with ISO, also take part in the work. ISO collaborates closely with the International Electrotechnical Commission (IEC) on all matters of electrotechnical standardization.

The procedures used to develop this document and those intended for its further maintenance are described in the ISO/IEC Directives, Part 1. In particular the different approval criteria needed for the different types of ISO documents should be noted. This document was drafted in accordance with the editorial rules of the ISO/IEC Directives, Part 2 (see www.iso.org/directives).

Attention is drawn to the possibility that some of the elements of this document may be the subject of patent rights. ISO shall not be held responsible for identifying any or all such patent rights. Details of any patent rights identified during the development of the document will be in the Introduction and/or on the ISO list of patent declarations received (see www.iso.org/patents).

Any trade name used in this document is information given for the convenience of users and does not constitute an endorsement.

For an explanation on the meaning of ISO specific terms and expressions related to conformity assessment, as well as information about ISO's adherence to the WTO principles in the Technical Barriers to Trade (TBT) see the following URL: [Foreword - Supplementary information](#)

The committee responsible for this document is ISO/TC 4, *Rolling bearings*, Subcommittee SC 4, *Tolerances, tolerance definitions and symbols (including GPS)*.

This fifth edition cancels and replaces the fourth edition (ISO 492:2002), which has been technically revised.

This corrected version of ISO 492:2014 incorporates the correction of the title.

Introduction

This International Standard is a machine element geometry standard as defined in the geometrical product specification (GPS) system as presented in master plan of ISO/TR 14638.^[12]

The fundamental rules of ISO/GPS given in ISO 8015^[8] apply to this International Standard and the default decision rules given in ISO 14253-1^[10] apply to the specifications made in accordance with this International Standard, unless otherwise indicated.

The connection between functional requirements, measuring technique and measuring uncertainty is always intended to be considered. The traditionally used measuring technique is described in ISO 1132-2.^[5] For measurement uncertainty it is intended that ISO 14253-2^[11] should be considered.

Rolling bearings — Radial bearings — Geometrical product specifications (GPS) and tolerance values

1 Scope

This International Standard specifies dimensional and geometrical characteristics, limit deviations from nominal sizes, and tolerance values to define the interface (except chamfers) of radial rolling bearings. Nominal boundary dimensions are defined in ISO 15, ISO 355[2] and ISO 8443[9].

This International Standard does not apply to certain radial bearings of particular types (e.g. needle roller bearings) or for particular fields of application (e.g. airframe bearings and instrument precision bearings). Tolerances for such bearings are given in the relevant International Standards.

Chamfer dimension limits are given in ISO 582.

2 Normative references

The following documents, in whole or in part, are normatively referenced in this document and are indispensable for its application. For dated references, only the edition cited applies. For undated references, the latest edition of the referenced document (including any amendments) applies.

ISO 15, *Rolling bearings — Radial bearings — Boundary dimensions, general plan*

ISO 582, *Rolling bearings — Chamfer dimensions — Maximum values*

ISO 1101, *Geometrical product specifications (GPS) — Geometrical tolerancing — Tolerances of form, orientation, location and run-out*

ISO 5593, *Rolling bearings — Vocabulary*

ISO 14405-1, *Geometrical product specifications (GPS) — Dimensional tolerancing — Part 1: Linear sizes*

ISO/TS 17863, *Geometrical product specification (GPS) — Geometrical tolerancing of moveable assemblies*

3 Terms and definitions

For the purposes of this document, the terms and definitions given in ISO 1101, ISO 5593, ISO 14405-1, and ISO/TS 17863 apply.

4 Symbols

To express that the ISO/GPS system, ISO 8015[8], is applied, the dimensional and geometrical characteristics shall be included in the technical product documentation (for example, on the drawing). The dimensional and geometrical specifications, associated to these characteristics are described in [Table 1](#) and [Figures 1](#) to [17](#).

Descriptions for symbols are in accordance with GPS terminology; relationships with traditional terms are described in [Annex A](#).

A tolerance value associated to a characteristic is symbolised by t followed by the symbol for the characteristic, for example t_{VB_s} .

In this International Standard, the ISO default specification operator for size is in accordance with ISO 14405-1, i.e. the two-point size is valid. Some specification modifiers are described in [Annex D](#).

The detailed definitions for terms in ISO 1101 and ISO 14405-1 and traditional terms in ISO 1132-1[4] are not fully equal. For differences, see [Annex C](#).

Table 1 — Symbols for nominal sizes, characteristics, and specification modifiers

Symbol for nominal dimension (size and distance) ^a	Symbol for characteristic ^a	GPS symbol and specification modifier ^{bc}	Description ^d	See Figure
B			Nominal inner ring width	1; 2; 12
	VBs		Symmetrical rings: range of two-point sizes of inner ring width	1; 12
			Asymmetrical rings: range of minimum circumscribed sizes of inner ring width, between two opposite lines, obtained from any longitudinal section which includes the inner ring bore axis	2; 7
	ΔBs		Symmetrical rings: deviation of a two-point size of inner ring width from its nominal size	1; 12
			Asymmetrical rings, upper limit: deviation of a minimum circumscribed size of inner ring width, between two opposite lines, in any longitudinal section which includes the inner ring bore axis, from its nominal size	2; 7
			Asymmetrical rings, lower limit: deviation of a two-point size of inner ring width from its nominal size	

Table 1 — (continued)

Symbol for nominal dimension (size and distance) ^a	Symbol for characteristic ^a	GPS symbol and specification modifier ^{bc}	Description ^d	See Figure
C			Nominal outer ring width	1; 7; 12
	VCs		Symmetrical rings: range of two-point sizes of outer ring width	1; 7
			Asymmetrical rings: range of minimum circumscribed sizes of outer ring width between two opposite lines, obtained from any longitudinal section which includes the outer ring outside surface axis	2; 12
	ΔCs		Symmetrical rings: deviation of a two-point size of outer ring width from its nominal size	1; 7
			Asymmetrical rings, upper limit: deviation of a minimum circumscribed size of outer ring width, between two opposite lines, in any longitudinal section which includes the outer ring outside surface axis, from its nominal size	2; 12
			Asymmetrical rings, lower limit: deviation of a two-point size of outer ring width from its nominal size	
C ₁			Nominal outer ring flange width	12
	VC1s		Range of two-point sizes of outer ring flange width	12
	ΔC1s		Deviation of a two-point size of outer ring flange width from its nominal size	12
d			Nominal bore diameter of a cylindrical bore or at the theoretical small end of a tapered bore	1 to 7; 12 to 16
	Vdmp		Range of mid-range sizes (out of two-point sizes) of bore diameter obtained from any cross-section of a cylindrical bore	1; 2; 12
	Δdmp		Cylindrical bore: deviation of a mid-range size (out of two-point sizes) of bore diameter in any cross-section from its nominal size	1; 2; 12
			Tapered bore: deviation of a mid-range size (out of two-point sizes) of bore diameter at the theoretical small end from its nominal size	7
	Vdsp		Range of two-point sizes of bore diameter in any cross-section of a cylindrical or tapered bore	1; 2; 7; 12
	Δds		Deviation of a two-point size of bore diameter of a cylindrical bore from its nominal size	1; 2; 12

Table 1 — (continued)

Symbol for nominal dimension (size and distance) ^a	Symbol for characteristic ^a	GPS symbol and specification modifier ^{bc}	Description ^d	See Figure
d_1			Nominal diameter at the theoretical large end of a tapered bore	7
	Δd_{1mp}	$\textcircled{\text{LP}} \textcircled{\text{SD}} \textcircled{\text{SCS}}^f$	Deviation of a mid-range size (out of two-point sizes) of bore diameter at the theoretical large end of a tapered bore from its nominal size	7
D			Nominal outside diameter	1 to 16
	VD_{mp}	$\textcircled{\text{LP}} \textcircled{\text{SD}} \textcircled{\text{ACS}} \textcircled{\text{SR}}$	Range of mid-range sizes (out of two-point sizes) of outside diameter obtained from any cross-section	1; 2; 7; 12
	ΔD_{mp}	$\textcircled{\text{LP}} \textcircled{\text{SD}} \textcircled{\text{ACS}}$	Deviation of a mid-range size (out of two-point sizes) of outside diameter in any cross-section from its nominal size	1; 2; 7; 12
	VD_{sp}	$\textcircled{\text{LP}} \textcircled{\text{SR}} \textcircled{\text{ACS}}$	Range of two-point sizes of outside diameter in any cross-section	1; 2; 7; 12
	ΔD_s	$\textcircled{\text{LP}}$	Deviation of a two-point size of outside diameter from its nominal size	1; 2; 7; 12
D_1			Nominal outside diameter of outer ring flange	12
	ΔD_{1s}	$\textcircled{\text{LP}}$	Deviation of a two-point size of outside diameter of outer ring flange from its nominal size	12
	Ke_a	\nearrow ^g	Circular radial run-out of outer ring outside surface of assembled bearing with respect to datum, i.e. axis, established from the inner ring bore surface	4; 5; 6; 9; 10; 11; 14; 15; 16
	Ki_a	\nearrow ^g	Circular radial run-out of inner ring bore surface of assembled bearing with respect to datum, i.e. axis, established from the outer ring outside surface	4; 5; 6; 9; 10; 11; 14; 15; 16
	S_d	\nearrow ^g	Circular axial run-out of inner ring face with respect to datum, i.e. axis, established from the inner ring bore surface	3; 8; 13
	SD	\perp	Perpendicularity of outer ring outside surface axis with respect to datum established from the outer ring face	3; 8
	SD_1	\perp	Perpendicularity of outer ring outside surface axis with respect to datum established from the outer ring flange back face	13

Table 1 — (continued)











Symbol for nominal dimension (size and distance) ^a	Symbol for characteristic ^a	GPS symbol and specification modifier ^{bc}	Description ^d	See Figure
	Sea	 g	Circular axial run-out of outer ring face of assembled bearing with respect to datum, i.e. axis, established from the inner ring bore surface	5; 6; 10; 11
	Sea1	 g	Circular axial run-out of outer ring flange back face of assembled bearing with respect to datum, i.e. axis, established from the inner ring bore surface	15; 16
	Sia	 g	Circular axial run-out of inner ring face of assembled bearing with respect to datum, i.e. axis, established from the outer ring outside surface	5; 6; 10; 11; 15; 16
SL^h			Taper slope is the difference between nominal diameters at the theoretical large end and small end of a tapered bore ($d_1 - d$)	7
	ΔSL		Deviation of taper slope of a tapered inner ring bore from its nominal size ⁱ	7
T			Nominal assembled bearing width	17
	ΔTs	 g	Deviation of minimum circumscribed size of assembled bearing width from its nominal size	17
T_1			Nominal effective width of inner subunit assembled with a master outer ring	17
	$\Delta T1s$	 g	Deviation of minimum circumscribed size of effective width (inner subunit assembled with a master outer ring) from its nominal size	17
T_2			Nominal effective width of outer ring assembled with a master inner subunit	17
	$\Delta T2s$	 g	Deviation of minimum circumscribed size of effective width (outer ring assembled with a master inner subunit) from its nominal size	17

Table 1 — (continued)

Symbol for nominal dimension (size and distance) ^a	Symbol for characteristic ^a	GPS symbol and specification modifier ^{bc}	Description ^d	See Figure
T_F			Nominal assembled flanged bearing width	17
	ΔTF_s	 ^g	Deviation of minimum circumscribed size of assembled flanged bearing width from its nominal size	17
T_{F2}			Nominal effective width of flanged outer ring assembled with a master inner subunit	17
	ΔTF_{2s}	 ^g	Deviation of minimum circumscribed size of effective width (flanged outer ring assembled with a master inner subunit) from its nominal size	17
α			Frustum angle of tapered inner ring bore ^h	7; 8; 9; 10; 11
a^k			Distance from face to define the restricted area for SD or SD1	3; 8; 13

a Symbols as defined in ISO 15241[15] except for the format used.
 b Symbols as defined in ISO 1101 and ISO 14405-1.
 c Specification modifier  shall not be indicated on a drawing, if the two-point size is applied for both specified limits.
 d Description based on ISO 1101, ISO 5459[Z] and ISO 14405-1.
 e Specification modifier  is not appropriate in cases where no opposite material is existing, e.g. tapered roller bearing outer ring with large back face chamfer and small front face. Solutions need to be developed within the framework of the GPS system and considered in future revisions of this International Standard.
 f Specification modifier **SCS** can be omitted on the drawing.
 g Symbols for direction of gravity , fixed parts **FP** and movable parts **MP**, according to ISO/TS 17863; see [Figures 4, 5, 6, 9, 10, 11, 14, 15, 16, and 17](#).
 h SL is a distance.
 i Description based on ISO 1119.[3]
 k For $r_{s,min} \leq 0,6$: $a = r_{s,max,axial} + 0,5$; for $r_{s,min} > 0,6$: $a = 1,2 \times r_{s,max,axial}$; $r_{s,max,axial}$ see ISO 582. For definitions of $r_{s,min}$ and $r_{s,max,axial}$ see ISO 582.

The indications in [Figures 1 to 17](#) illustrate the correlation of interface dimensions and corresponding dimensional and geometrical tolerance symbols.

The specifications for single components are illustrated in [Figures 1, 2, 3, 7, 8, 12, and 13](#). The specifications for assembled components are illustrated in [Figures 4, 5, 6, 9, 10, 11, 14, 15, 16, and 17](#).

NOTE [Figures 1 to 17](#) are drawn schematically and do not necessarily show all design details.

Two examples of a real drawing indication are given in [Annex B](#).

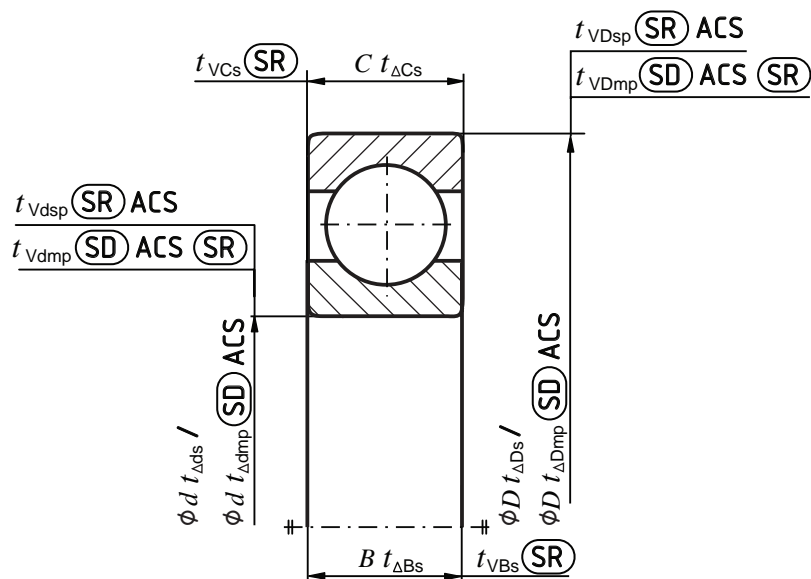
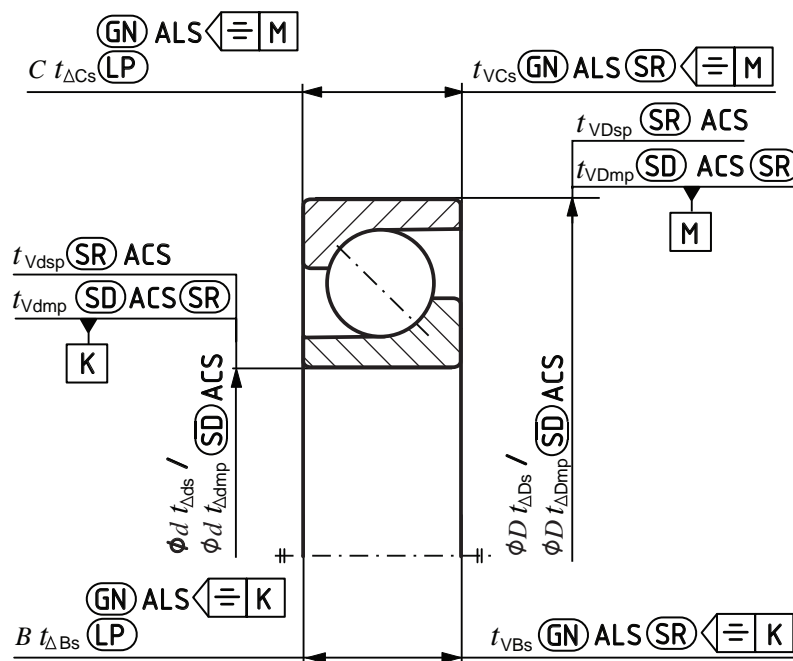

Figure 1 — Size specification for single components for bearing with cylindrical bore and symmetrical rings



NOTE t_{VBs} and t_{VCs} are not relevant for tapered roller bearings.

Figure 2 — Size specification for single components for bearing with cylindrical bore and asymmetrical rings

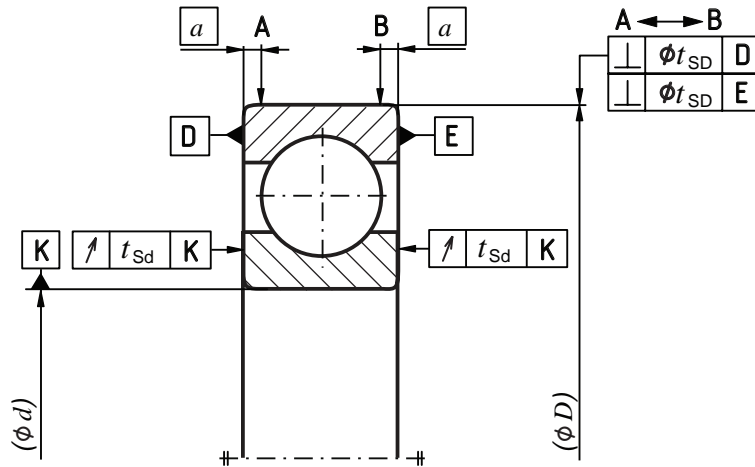
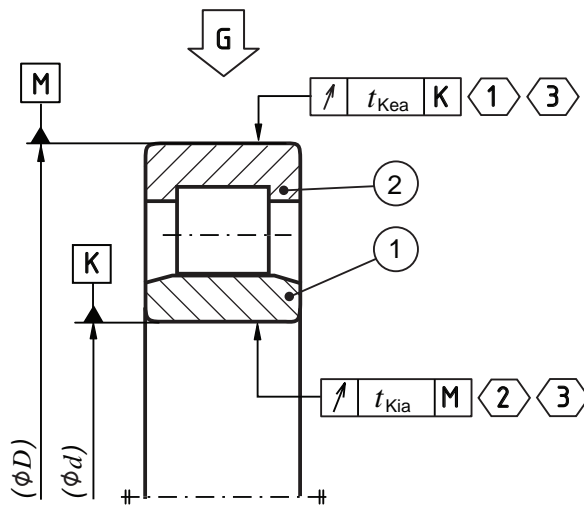

Figure 3 — Geometrical tolerances for single components for bearing with cylindrical bore



① ≡ FP ① - MP ②, G

② ≡ FP ② - MP ①, G

③ ≡ the rolling elements shall be in contact with both the inner and outer ring raceways

Figure 4 — Geometrical tolerances for assembled bearing with cylindrical bore — Cylindrical roller bearing, spherical roller bearing, toroidal roller bearing and self-aligning ball bearing

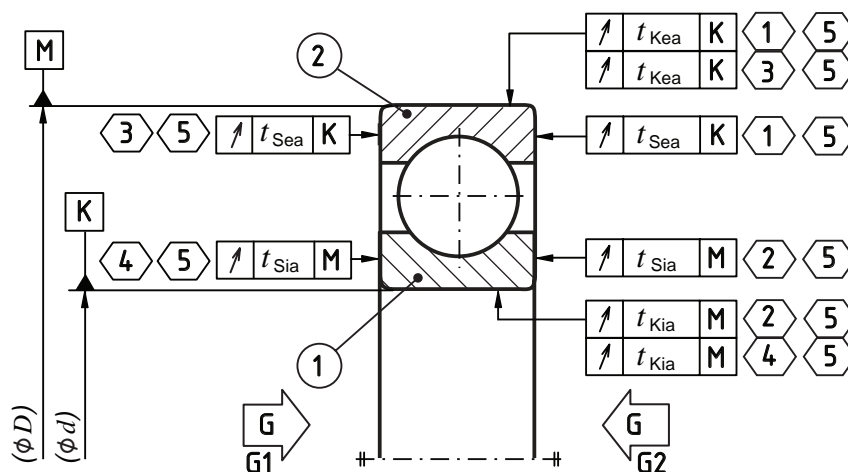

① ≡ FP ① - MP ②, G2

② ≡ FP ② - MP ①, G2

③ ≡ FP ① - MP ②, G1

④ ≡ FP ② - MP ①, G1

⑤ ≡ the rolling elements shall be in contact with both the inner and outer ring raceways

Figure 5 — Geometrical tolerances for assembled bearing with cylindrical bore — Deep-groove ball bearing, double-row deep-groove ball bearing, double-row angular contact ball bearing and four-point-contact ball bearing

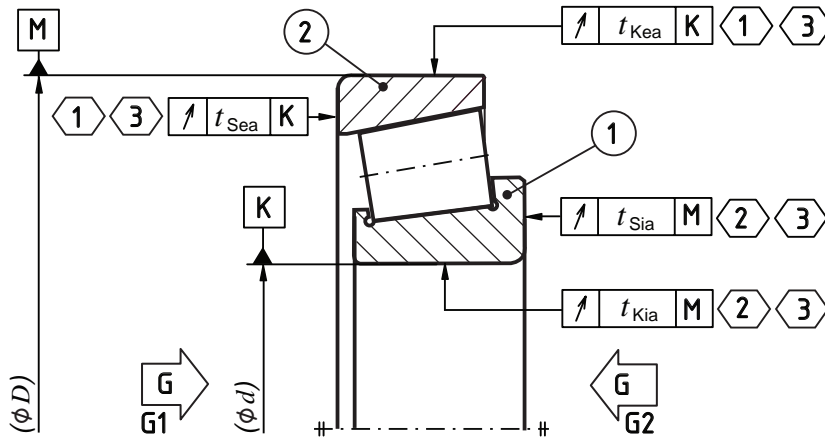

① ≡ FP ① - MP ②, G1

② ≡ FP ② - MP ①, G2

③ ≡ the rolling elements shall be in contact with both the inner and outer ring raceways and, in a tapered roller bearing, the inner ring back face rib

Figure 6 — Geometrical tolerances for assembled bearing with cylindrical bore — Single-row angular contact ball bearing and tapered roller bearing

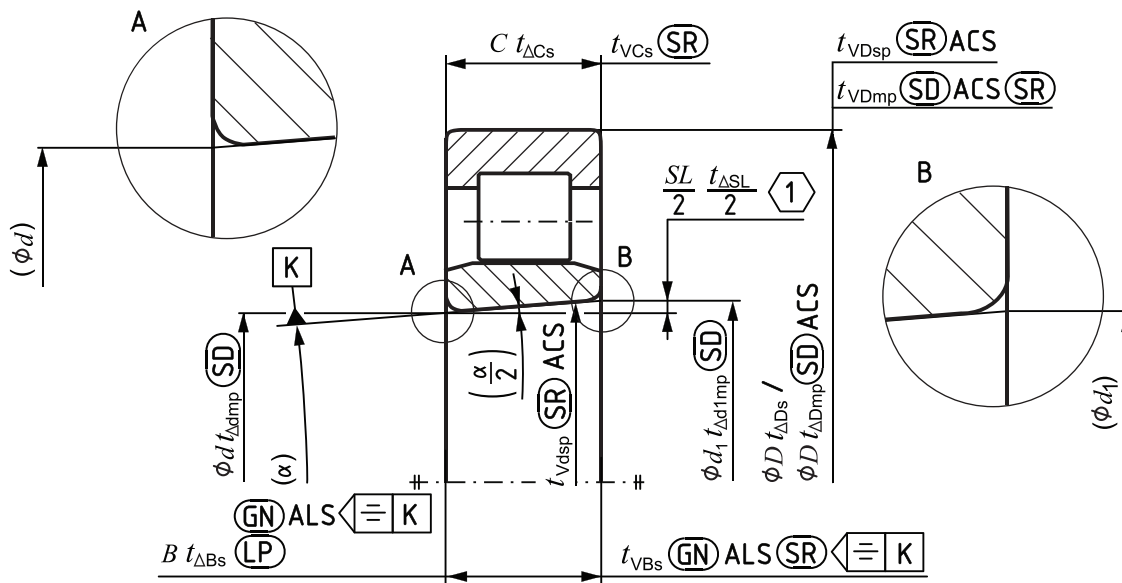

① ≡ SL is a calculated nominal size from d and d_1 , i.e. $SL = (d_1 - d) = 2B \tan(\alpha/2)$; ΔSL is a calculated characteristic, i.e. $\Delta SL = \Delta d_{1mp} - \Delta d_{mp}$

NOTE For indications on asymmetrical outer rings, see [Figure 2](#).

Figure 7 — Size specification for single components for bearing with tapered bore

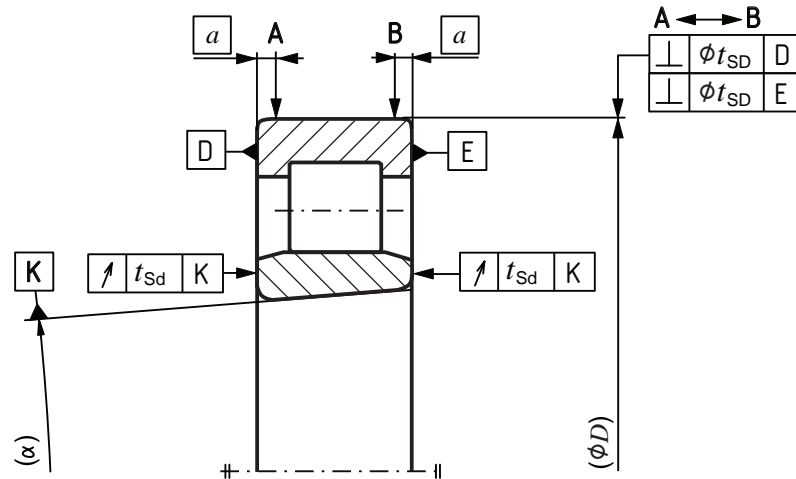
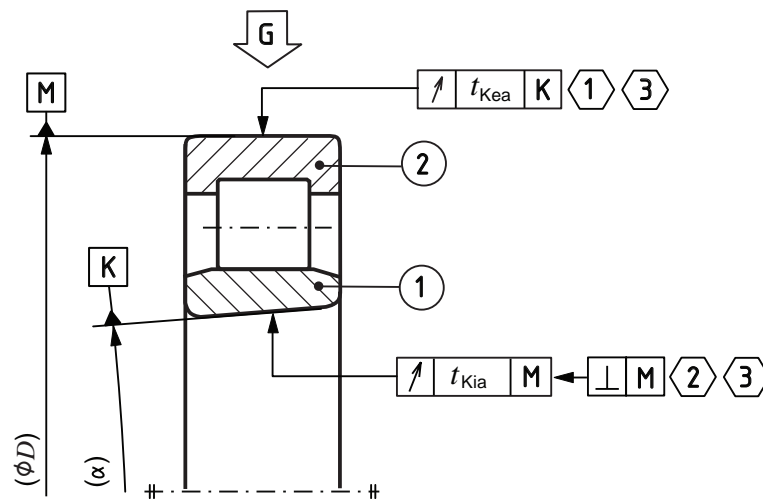

Figure 8 — Geometrical tolerances for single components for bearing with tapered bore



① ≡ FP (1) - MP (2), G

② ≡ FP (2) - MP (1), G

③ ≡ the rolling elements shall be in contact with both the inner and outer ring raceways

Figure 9 — Geometrical tolerances for assembled bearing with tapered bore — Cylindrical roller bearing, spherical roller bearing, toroidal roller bearing and self-aligning ball bearing

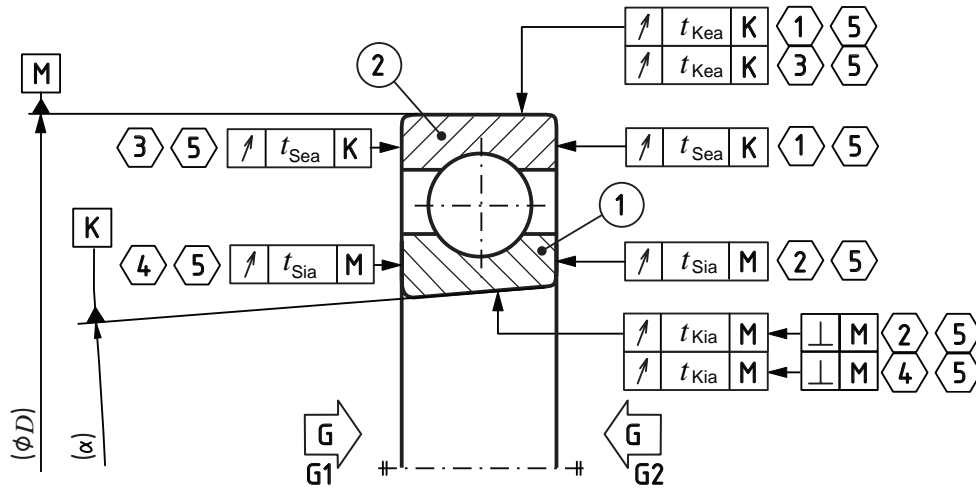

① ≡ FP ① - MP ②, G2

② ≡ FP ② - MP ①, G2

③ ≡ FP ① - MP ②, G1

④ ≡ FP ② - MP ①, G1

⑤ ≡ the rolling elements shall be in contact with both the inner and outer ring raceways

Figure 10 — Geometrical tolerances for assembled bearing with tapered bore — Deep-groove ball bearing, double-row deep-groove ball bearing, double-row angular contact ball bearing and four-point-contact ball bearing

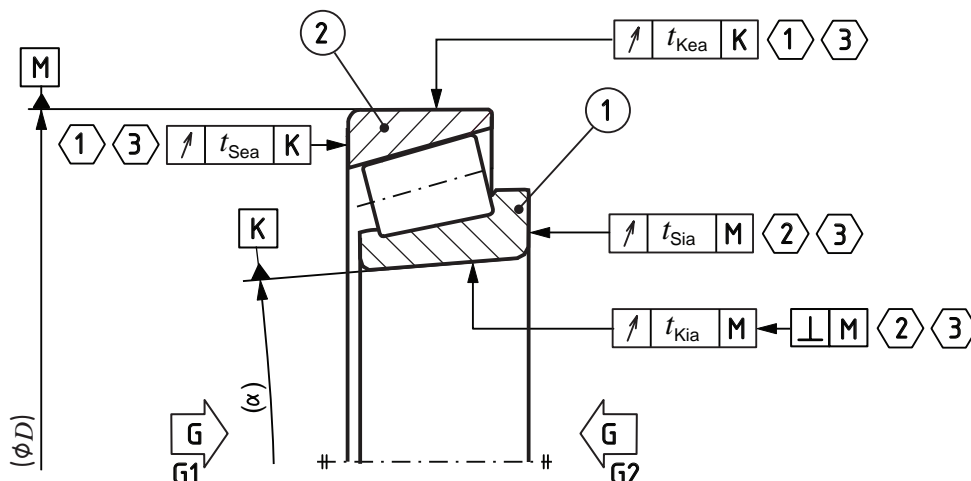

① ≡ FP ① - MP ②, G1

② ≡ FP ② - MP ①, G2

③ ≡ the rolling elements shall be in contact with both the inner and outer ring raceways and, in a tapered roller bearing, the inner ring back face rib

Figure 11 — Geometrical tolerances for assembled bearing with tapered bore — Single-row angular contact ball bearing and tapered roller bearing

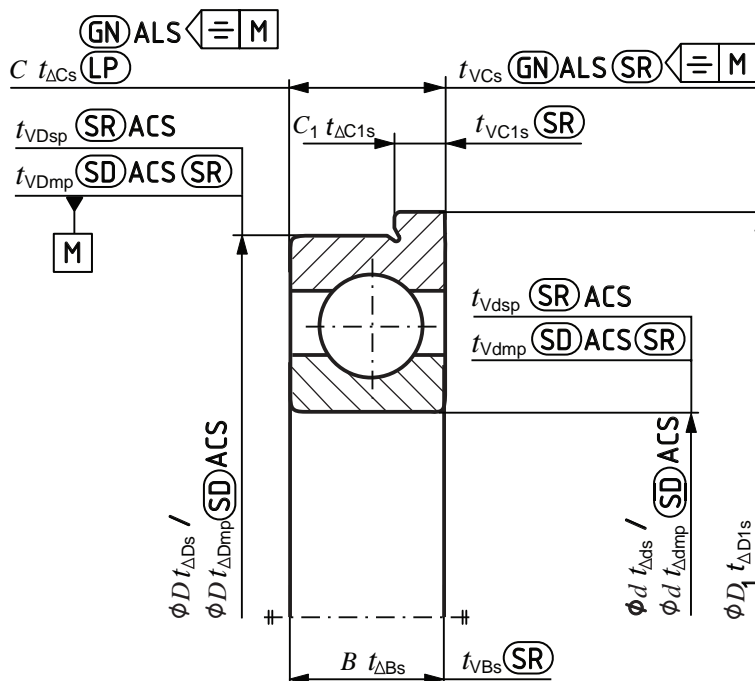

NOTE See Figure 2 for indications on asymmetrical inner ring.

Figure 12 — Size specification for single components for bearing with flanged outer ring

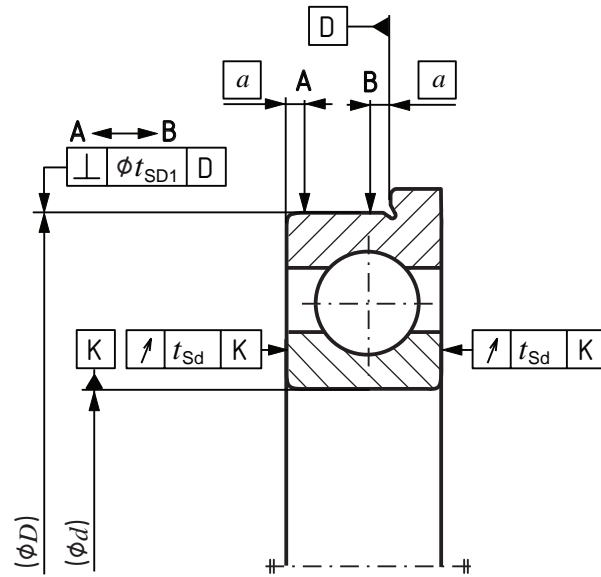
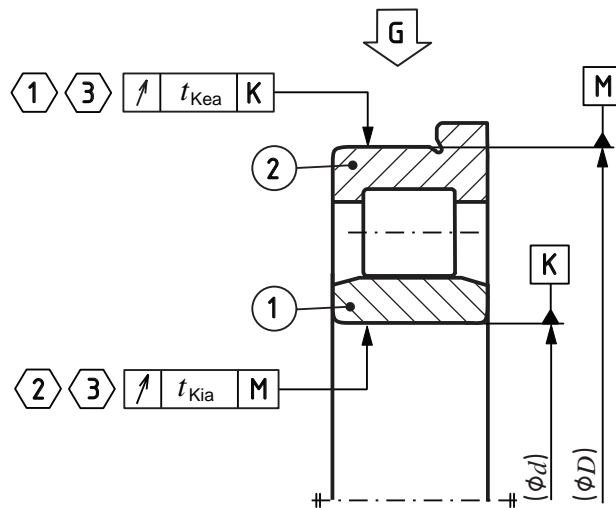

Figure 13 — Geometrical tolerances for single components for bearing with flanged outer ring



① = FP ① - MP ②, G

② = FP ② - MP ①, G

③ = the rolling elements shall be in contact with both the inner and outer ring raceways

Figure 14 — Geometrical tolerances for assembled bearing with flanged outer ring — Cylindrical roller bearing, spherical roller bearing, toroidal roller bearing and self-aligning ball bearing

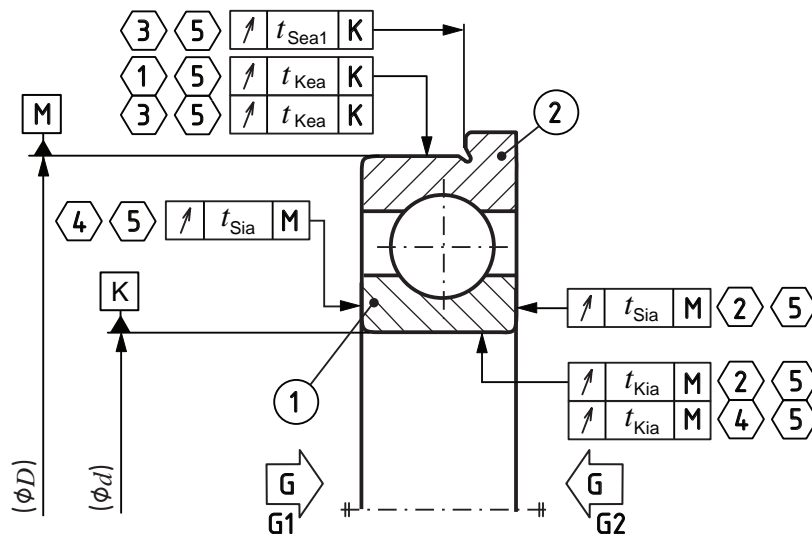

① ≡ FP ① - MP ②, G2

② ≡ FP ② - MP ①, G2

③ ≡ FP ① - MP ②, G1

④ ≡ FP ② - MP ①, G1

⑤ ≡ the rolling elements shall be in contact with both the inner and outer ring raceways

Figure 15 — Geometrical tolerances for assembled bearing with flanged outer ring — Deep-groove ball bearing, double-row deep-groove ball bearing, double-row angular contact ball bearing and four-point-contact ball bearing

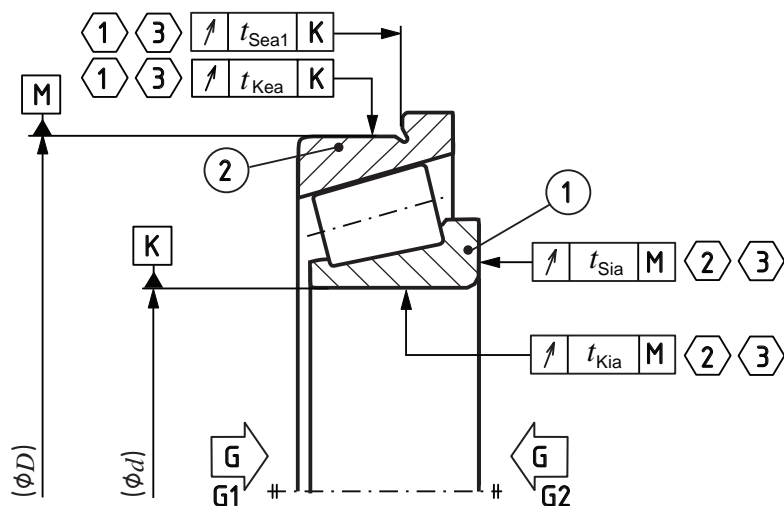

① ≡ FP ① - MP ②, G1

② ≡ FP ② - MP ①, G2

③ ≡ the rolling elements shall be in contact with both the inner and outer ring raceways and, in a tapered roller bearing, the inner ring back face rib

Figure 16 — Geometrical tolerances for assembled bearing with flanged outer ring — Single-row angular contact ball bearing and tapered roller bearing

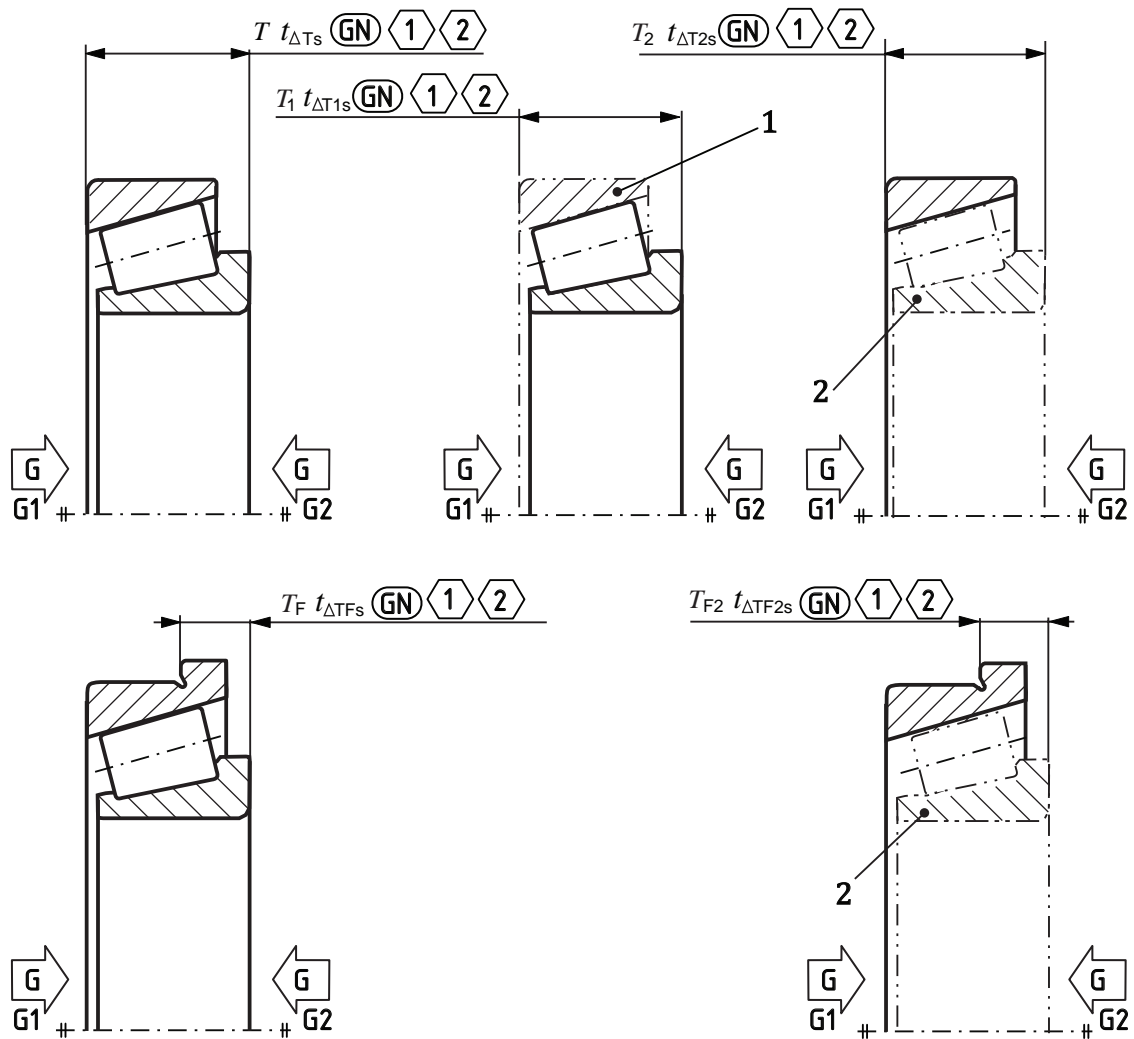

① = G1 or G2

② = the rolling elements shall be in contact with both the inner and outer ring raceways and the inner ring back face rib

Key

- 1 master outer ring
- 2 master inner subunit

Figure 17 — Additional symbols for assembled tapered roller bearings

5 Limit deviations and tolerance values

5.1 General

The bore diameter limit deviations and tolerance values for cylindrical bores are given in 5.2 and 5.3 and for flanges in 5.4. The limit deviations and tolerance values for tapered bore are given in 5.5.

The diameter series referred to in [Tables 2 to 11](#) are those defined in ISO 15. In the [Tables 2 to 27](#) the symbols U and L are used as follows:

- U = upper limit deviation;
- L = lower limit deviation.

5.2 Radial bearings except tapered roller bearings

5.2.1 Tolerance class — Normal

See [Tables 2](#) and [3](#).

Table 2 — Radial bearings except tapered roller bearings — Inner ring — Tolerance class — Normal

Limit deviations and tolerance values in micrometres

d mm		t _{Δdmp}		t _{Vdsp}			t _{Vdmp}	t _{Kia}	t _{ΔBs}			t _{VBs}
				Diameter series					All	Normal	Modified ^a	
>	≤	U	L	9	0, 1	2, 3, 4			U	L		
—	0,6	0	-8	10	8	6	6	10	0	-40	—	12
0,6	2,5	0	-8	10	8	6	6	10	0	-40	—	12
2,5	10	0	-8	10	8	6	6	10	0	-120	-250	15
10	18	0	-8	10	8	6	6	10	0	-120	-250	20
18	30	0	-10	13	10	8	8	13	0	-120	-250	20
30	50	0	-12	15	12	9	9	15	0	-120	-250	20
50	80	0	-15	19	19	11	11	20	0	-150	-380	25
80	120	0	-20	25	25	15	15	25	0	-200	-380	25
120	180	0	-25	31	31	19	19	30	0	-250	-500	30
180	250	0	-30	38	38	23	23	40	0	-300	-500	30
250	315	0	-35	44	44	26	26	50	0	-350	-500	35
315	400	0	-40	50	50	30	30	60	0	-400	-630	40
400	500	0	-45	56	56	34	34	65	0	-450	—	50
500	630	0	-50	63	63	38	38	70	0	-500	—	60
630	800	0	-75	—	—	—	—	80	0	-750	—	70
800	1 000	0	-100	—	—	—	—	90	0	-1 000	—	80
1 000	1 250	0	-125	—	—	—	—	100	0	-1 250	—	100
1 250	1 600	0	-160	—	—	—	—	120	0	-1 600	—	120
1 600	2 000	0	-200	—	—	—	—	140	0	-2 000	—	140

^a Applies to inner rings and outer rings of single bearings made for paired and stack assemblies. Also applies to inner rings with tapered bore with $d \geq 50$ mm.

Table 3 — Radial bearings except tapered roller bearings — Outer ring — Tolerance class — Normal

Limit deviations and tolerance values in micrometres

D mm		t _{ΔDmp}		t _{VDsp} ^a				t _{VDmp} ^a	t _{Kea}	t _{ΔCs}		t _{VCs} t _{VC1s} ^b
				Open bearings		Capped bearings				t _{ΔC1s} ^b		
				Diameter series						U	L	
>	≤	U	L	9	0, 1	2, 3, 4	2, 3, 4			U	L	
—	2,5	0	-8	10	8	6	10	6	15	Identical to t _{ΔBs} and t _{VBs} of an inner ring of the same bearing as the outer ring		
2,5	6	0	-8	10	8	6	10	6	15			
6	18	0	-8	10	8	6	10	6	15			
18	30	0	-9	12	9	7	12	7	15			
30	50	0	-11	14	11	8	16	8	20			
50	80	0	-13	16	13	10	20	10	25			
80	120	0	-15	19	19	11	26	11	35			
120	150	0	-18	23	23	14	30	14	40			
150	180	0	-25	31	31	19	38	19	45			
180	250	0	-30	38	38	23	—	23	50			
250	315	0	-35	44	44	26	—	26	60			
315	400	0	-40	50	50	30	—	30	70			
400	500	0	-45	56	56	34	—	34	80			
500	630	0	-50	63	63	38	—	38	100			
630	800	0	-75	94	94	55	—	55	120			
800	1 000	0	-100	125	125	75	—	75	140			
1 000	1 250	0	-125	—	—	—	—	—	160			
1 250	1 600	0	-160	—	—	—	—	—	190			
1 600	2 000	0	-200	—	—	—	—	—	220			
2 000	2 500	0	-250	—	—	—	—	—	250			

NOTE The limit deviations for the outside diameter, D₁, of an outer ring flange are given in [Table 25](#).

^a Applies before mounting and after removal of internal or external snap ring.

^b Applies to groove ball bearings only.

5.2.2 Tolerance class 6

See [Tables 4](#) and [5](#).

Table 4 — Radial bearings except tapered roller bearings — Inner ring — Tolerance class 6

Limit deviations and tolerance values in micrometres

<i>d</i> mm		<i>t</i> _{Δdmp}		<i>t</i> _{Vdsp}			<i>t</i> _{Vdmp}	<i>t</i> _{Kia}	<i>t</i> _{ΔBs}			<i>t</i> _{VBs}
				Diameter series					All	Normal	Modified ^a	
>	≤	U	L	9	0, 1	2, 3, 4			U	L		
—	0,6	0	-7	9	7	5	5	5	0	-40	—	12
0,6	2,5	0	-7	9	7	5	5	5	0	-40	—	12
2,5	10	0	-7	9	7	5	5	6	0	-120	-250	15
10	18	0	-7	9	7	5	5	7	0	-120	-250	20
18	30	0	-8	10	8	6	6	8	0	-120	-250	20
30	50	0	-10	13	10	8	8	10	0	-120	-250	20
50	80	0	-12	15	15	9	9	10	0	-150	-380	25
80	120	0	-15	19	19	11	11	13	0	-200	-380	25
120	180	0	-18	23	23	14	14	18	0	-250	-500	30
180	250	0	-22	28	28	17	17	20	0	-300	-500	30
250	315	0	-25	31	31	19	19	25	0	-350	-500	35
315	400	0	-30	38	38	23	23	30	0	-400	-630	40
400	500	0	-35	44	44	26	26	35	0	-450	—	45
500	630	0	-40	50	50	30	30	40	0	-500	—	50

^a Applies to inner rings and outer rings of single bearings made for paired and stack assemblies. Also applies to inner rings with tapered bore with *d* ≥ 50 mm.

Table 5 — Radial bearings except tapered roller bearings — Outer ring — Tolerance class 6

Limit deviations and tolerance values in micrometres

D mm		t _{ΔDmp}		t _{VDsp} ^a				t _{VDmp} ^a	t _{Kea}	t _{ΔCs} t _{ΔC1s} ^b		t _{VCs} t _{VC1s} ^b
				Open bearings		Capped bearings				U	L	
>	≤	U	L	Diameter series								
				9	0, 1	2, 3, 4	0, 1, 2, 3, 4					
—	2,5	0	-7	9	7	5	9	5	8	Identical to t _{ΔBs} and t _{VBs} of an inner ring of the same bearing as the outer ring		
2,5	6	0	-7	9	7	5	9	5	8			
6	18	0	-7	9	7	5	9	5	8			
18	30	0	-8	10	8	6	10	6	9			
30	50	0	-9	11	9	7	13	7	10			
50	80	0	-11	14	11	8	16	8	13			
80	120	0	-13	16	16	10	20	10	18			
120	150	0	-15	19	19	11	25	11	20			
150	180	0	-18	23	23	14	30	14	23			
180	250	0	-20	25	25	15	—	15	25			
250	315	0	-25	31	31	19	—	19	30			
315	400	0	-28	35	35	21	—	21	35			
400	500	0	-33	41	41	25	—	25	40			
500	630	0	-38	48	48	29	—	29	50			
630	800	0	-45	56	56	34	—	34	60			
800	1 000	0	-60	75	75	45	—	45	75			

NOTE The limit deviations for the outside diameter, D₁, of an outer ring flange are given in [Table 25](#).

^a Applies before mounting and after removal of internal or external snap ring.

^b Applies to groove ball bearings only.

5.2.3 Tolerance class 5

See [Tables 6](#) and [7](#).

Table 6 — Radial bearings except tapered roller bearings — Inner ring — Tolerance class 5

Limit deviations and tolerance values in micrometres

d mm		t _{Δdmp}		t _{Vdsp}		t _{Vdmp}	t _{Kia}	t _{Sd}	t _{Sia} ^a	t _{ΔBs}			t _{VBs}
				Diameter series						All	Normal	Modified ^b	
>	≤	U	L	9	0, 1, 2, 3, 4					U	L		
—	0,6	0	-5	5	4	3	4	7	7	0	-40	-250	5
0,6	2,5	0	-5	5	4	3	4	7	7	0	-40	-250	5
2,5	10	0	-5	5	4	3	4	7	7	0	-40	-250	5
10	18	0	-5	5	4	3	4	7	7	0	-80	-250	5
18	30	0	-6	6	5	3	4	8	8	0	-120	-250	5
30	50	0	-8	8	6	4	5	8	8	0	-120	-250	5
50	80	0	-9	9	7	5	5	8	8	0	-150	-250	6
80	120	0	-10	10	8	5	6	9	9	0	-200	-380	7
120	180	0	-13	13	10	7	8	10	10	0	-250	-380	8
180	250	0	-15	15	12	8	10	11	13	0	-300	-500	10
250	315	0	-18	18	14	9	13	13	15	0	-350	-500	13
315	400	0	-23	23	18	12	15	15	20	0	-400	-630	15

^a Applies to groove ball bearings only.

^b Applies to inner rings and outer rings of single bearings made for paired and stack assemblies. Also applies to inner rings with tapered bore with d ≥ 50 mm.

Table 7 — Radial bearings except tapered roller bearings — Outer ring — Tolerance class 5

Limit deviations and tolerance values in micrometres

<i>D</i> mm		<i>t</i> _{ΔDmp}		<i>t</i> _{VDsp} ^{ab}		<i>t</i> _{VDmp} ^b	<i>t</i> _{Kea}	<i>t</i> _{SD} ^{ce} <i>t</i> _{SD1} ^{de}	<i>t</i> _{Sea} ^{cd}	<i>t</i> _{Sea1} ^d	<i>t</i> _{ΔCs}		<i>t</i> _{VCs} <i>t</i> _{VC1s} ^d	
				Diameter series							<i>t</i> _{ΔC1s} ^d			
>	≤	U	L	9	0, 1, 2, 3, 4						U	L		
—	2,5	0	-5	5	4	3	5	4	8	11	Identical to <i>t</i> _{ΔBs} of an inner ring of the same bearing as the outer ring		5	
2,5	6	0	-5	5	4	3	5	4	8	11			5	
6	18	0	-5	5	4	3	5	4	8	11			5	
18	30	0	-6	6	5	3	6	4	8	11			5	
30	50	0	-7	7	5	4	7	4	8	11			5	
50	80	0	-9	9	7	5	8	4	10	14			6	
80	120	0	-10	10	8	5	10	4,5	11	16			8	
120	150	0	-11	11	8	6	11	5	13	18			8	
150	180	0	-13	13	10	7	13	5	14	20			8	
180	250	0	-15	15	11	8	15	5,5	15	21			10	
250	315	0	-18	18	14	9	18	6,5	18	25		11		
315	400	0	-20	20	15	10	20	6,5	20	28		13		
400	500	0	-23	23	17	12	23	7,5	23	33		15		
500	630	0	-28	28	21	14	25	9	25	35		18		
630	800	0	-35	35	26	18	30	10	30	42		20		

NOTE The limit deviations for the outside diameter, *D*₁, of an outer ring flange are given in [Table 25](#).

- a No values have been established for capped bearings.
- b Applies before mounting and after removal of internal or external snap ring.
- c Does not apply to bearings with flanged outer ring.
- d Applies to groove ball bearings only.
- e Tolerance values have become half the values compared to the previous edition of this International Standard because in this edition, SD and SD1 are defined as perpendicularity of outer ring outside surface axis with respect to datum established from the outer ring face or the outer ring flange back face.

5.2.4 Tolerance class 4

See [Tables 8](#) and [9](#).

Table 8 — Radial bearings except tapered roller bearings — Inner ring — Tolerance class 4

Limit deviations and tolerance values in micrometres

d mm		t _{Δdmp} ^a t _{Δds} ^b		t _{Vdsp}		t _{Vdmp}	t _{Kia}	t _{Sd}	t _{Sia} ^c	t _{ΔBs}			t _{VBs}
				Diameter series						All	Normal	Modified ^d	
>	≤	U	L	9	0, 1, 2, 3, 4					U	L		
—	0,6	0	-4	4	3	2	2,5	3	3	0	-40	-250	2,5
0,6	2,5	0	-4	4	3	2	2,5	3	3	0	-40	-250	2,5
2,5	10	0	-4	4	3	2	2,5	3	3	0	-40	-250	2,5
10	18	0	-4	4	3	2	2,5	3	3	0	-80	-250	2,5
18	30	0	-5	5	4	2,5	3	4	4	0	-120	-250	2,5
30	50	0	-6	6	5	3	4	4	4	0	-120	-250	3
50	80	0	-7	7	5	3,5	4	5	5	0	-150	-250	4
80	120	0	-8	8	6	4	5	5	5	0	-200	-380	4
120	180	0	-10	10	8	5	6	6	7	0	-250	-380	5
180	250	0	-12	12	9	6	8	7	8	0	-300	-500	6

^a These deviations apply to diameter series 9 only.

^b These deviations apply to diameter series 0, 1, 2, 3 and 4 only.

^c Applies to groove ball bearings only.

^d Applies to inner rings and outer rings of single bearings made for paired or stack assemblies.

Table 9 — Radial bearings except tapered roller bearings — Outer ring — Tolerance class 4

Limit deviations and tolerance values in micrometres

D mm		t _{ΔDmp} ^a t _{ΔDs} ^b		t _{VDsp} ^{cd}		t _{VDmp} ^d	t _{Kea}	t _{SD} ^{ef} t _{SD1} ^{fg}	t _{Sea} ^{eg}	t _{Sea1} ^g	t _{ΔCs}		t _{VCs}		
				9	0, 1, 2, 3, 4						t _{ΔC1s} ^g		t _{VC1s} ^g		
>	≤	U	L									U	L		
—	2,5	0	-4	4	3	2	3	2	5	7	Identical to t _{ΔBs} of an inner ring of the same bearing as the outer ring			2,5	
2,5	6	0	-4	4	3	2	3	2	5	7				2,5	
6	18	0	-4	4	3	2	3	2	5	7				2,5	
18	30	0	-5	5	4	2,5	4	2	5	7				2,5	
30	50	0	-6	6	5	3	5	2	5	7				2,5	
50	80	0	-7	7	5	3,5	5	2	5	7				3	
80	120	0	-8	8	6	4	6	2,5	6	8				4	
120	150	0	-9	9	7	5	7	2,5	7	10				5	
150	180	0	-10	10	8	5	8	2,5	8	11				5	
180	250	0	-11	11	8	6	10	3,5	10	14				7	
250	315	0	-13	13	10	7	11	4	10	14			7		
315	400	0	-15	15	11	8	13	5	13	18			8		

NOTE The limit deviations for the outside diameter, *D*₁, of an outer ring flange are given in [Table 25](#).

a These deviations apply to diameter series 9 only.

b These deviations apply to diameter series 0, 1, 2, 3 and 4 only.

c No values have been established for capped bearings.

d Applies before mounting and after removal of internal or external snap ring.

e Does not apply to bearings with flanged outer ring.

f Tolerance values have become half the values compared to the previous edition of this International Standard because in this edition, SD and SD1 are defined as perpendicularity of outer ring outside surface axis with respect to datum established from the outer ring face or the outer ring flange back face.

g Applies to groove ball bearings only.

5.2.5 Tolerance class 2

See [Tables 10](#) and [11](#).

Table 10 — Radial bearings except tapered roller bearings — Inner ring — Tolerance class 2

Limit deviations and tolerance values in micrometres

d mm		t _{Δdmp} ^a t _{Δds} ^b		t _{Vdsp}	t _{Vdmp}	t _{Kia}	t _{Sd}	t _{Sia} ^c	t _{ΔBs}			t _{VBs}
									All	Normal	Modified ^d	
>	≤	U	L						U	L		
—	0,6	0	-2,5	2,5	1,5	1,5	1,5	1,5	0	-40	-250	1,5
0,6	2,5	0	-2,5	2,5	1,5	1,5	1,5	1,5	0	-40	-250	1,5
2,5	10	0	-2,5	2,5	1,5	1,5	1,5	1,5	0	-40	-250	1,5
10	18	0	-2,5	2,5	1,5	1,5	1,5	1,5	0	-80	-250	1,5
18	30	0	-2,5	2,5	1,5	2,5	1,5	2,5	0	-120	-250	1,5
30	50	0	-2,5	2,5	1,5	2,5	1,5	2,5	0	-120	-250	1,5
50	80	0	-4	4	2	2,5	1,5	2,5	0	-150	-250	1,5
80	120	0	-5	5	2,5	2,5	2,5	2,5	0	-200	-380	2,5
120	150	0	-7	7	3,5	2,5	2,5	2,5	0	-250	-380	2,5
150	180	0	-7	7	3,5	5	4	5	0	-250	-380	4
180	250	0	-8	8	4	5	5	5	0	-300	-500	5

^a Applies to diameter series 9 only.

^b Applies to diameter series 0, 1, 2, 3, and 4 only.

^c Applies to groove ball bearings only.

^d Applies to inner rings and outer rings of single bearings made for paired or stack assemblies.

Table 11 — Radial bearings except tapered roller bearings — Outer ring — Tolerance class 2

Limit deviations and tolerance values in micrometres

D mm		t _{ΔDmp} ^a		t _{VDsp} ^{cd}	t _{VDmp} ^d	t _{Kea}	t _{SD} ^{ef} t _{SD1} ^{fg}	t _{Sea} ^{eg}	t _{Sea1} ^g	t _{ΔCs}		t _{VCs} t _{VC1s} ^g	
		t _{ΔDs} ^b								U	L		U
>	≤	U	L										
—	2,5	0	-2,5	2,5	1,5	1,5	0,75	1,5	3	Identical to t _{ΔBs} of an inner ring of the same bearing as the outer ring		1,5	
2,5	6	0	-2,5	2,5	1,5	1,5	0,75	1,5	3			1,5	
6	18	0	-2,5	2,5	1,5	1,5	0,75	1,5	3			1,5	
18	30	0	-4	4	2	2,5	0,75	2,5	4			1,5	
30	50	0	-4	4	2	2,5	0,75	2,5	4			1,5	
50	80	0	-4	4	2	4	0,75	4	6			1,5	
80	120	0	-5	5	2,5	5	1,25	5	7			2,5	
120	150	0	-5	5	2,5	5	1,25	5	7			2,5	
150	180	0	-7	7	3,5	5	1,25	5	7			2,5	
180	250	0	-8	8	4	7	2	7	10			4	
250	315	0	-8	8	4	7	2,5	7	10	5			
315	400	0	-10	10	5	8	3,5	8	11	7			

NOTE The limit deviations for the outside diameter, D₁, of an outer ring flange are given in [Table 25](#).

a These deviations apply to diameter series 9 only.

b These deviations apply to diameter series 0, 1, 2, 3 and 4 only.

c No values have been established for capped bearings.

d Applies before mounting and after removal of internal or external snap ring.

e Does not apply to bearings with flanged outer ring.

f Tolerance values have become half the values compared to the previous edition of this International Standard because in this edition, SD and SD1 are defined as perpendicularity of outer ring outside surface axis with respect to datum established from the outer ring face or the outer ring flange back face.

g Applies to groove ball bearings only.

5.3 Radial tapered roller bearings

5.3.1 Tolerance class — Normal

See [Tables 12](#) to [14](#).

Table 12 — Radial tapered roller bearings — Inner ring — Tolerance class — Normal

Limit deviations and tolerance values in micrometres

d mm		$t_{\Delta dmp}$		t_{Vdsp}	t_{Vdmp}	t_{Kia}
>	≤	U	L			
—	10	0	-12	12	9	15
10	18	0	-12	12	9	15
18	30	0	-12	12	9	18
30	50	0	-12	12	9	20
50	80	0	-15	15	11	25
80	120	0	-20	20	15	30
120	180	0	-25	25	19	35
180	250	0	-30	30	23	50
250	315	0	-35	35	26	60
315	400	0	-40	40	30	70
400	500	0	-45	45	34	80
500	630	0	-60	60	40	90
630	800	0	-75	75	45	100
800	1 000	0	-100	100	55	115
1 000	1 250	0	-125	125	65	130
1 250	1 600	0	-160	160	80	150
1 600	2 000	0	-200	200	100	170

Table 13 — Radial tapered roller bearings — Outer ring — Tolerance class — Normal

Limit deviations and tolerance values in micrometres

D mm		$t_{\Delta Dmp}$		t_{VDsp}	t_{VDmp}	t_{Kea}
$>$	\leq	U	L			
—	18	0	-12	12	9	18
18	30	0	-12	12	9	18
30	50	0	-14	14	11	20
50	80	0	-16	16	12	25
80	120	0	-18	18	14	35
120	150	0	-20	20	15	40
150	180	0	-25	25	19	45
180	250	0	-30	30	23	50
250	315	0	-35	35	26	60
315	400	0	-40	40	30	70
400	500	0	-45	45	34	80
500	630	0	-50	60	38	100
630	800	0	-75	80	55	120
800	1 000	0	-100	100	75	140
1 000	1 250	0	-125	130	90	160
1 250	1 600	0	-160	170	100	180
1 600	2 000	0	-200	210	110	200
2 000	2 500	0	-250	265	120	220

NOTE The limit deviations for the outside diameter, D_1 , of an outer ring flange are given in [Table 25](#).

Table 14 — Radial tapered roller bearings — Width — Inner rings, outer rings, single-row bearings and single-row subunits — Tolerance class — Normal

Limit deviation values in micrometres

<i>d</i> mm		<i>t</i> _{ΔBs}		<i>t</i> _{ΔCs}		<i>t</i> _{ΔTs}		<i>t</i> _{ΔT1s}		<i>t</i> _{ΔT2s}	
						<i>t</i> _{ΔTFs}				<i>t</i> _{ΔTF2s}	
>	≤	U	L	U	L	U	L	U	L	U	L
—	10	0	-120	0	-120	+200	0	+100	0	+100	0
10	18	0	-120	0	-120	+200	0	+100	0	+100	0
18	30	0	-120	0	-120	+200	0	+100	0	+100	0
30	50	0	-120	0	-120	+200	0	+100	0	+100	0
50	80	0	-150	0	-150	+200	0	+100	0	+100	0
80	120	0	-200	0	-200	+200	-200	+100	-100	+100	-100
120	180	0	-250	0	-250	+350	-250	+150	-150	+200	-100
180	250	0	-300	0	-300	+350	-250	+150	-150	+200	-100
250	315	0	-350	0	-350	+350	-250	+150	-150	+200	-100
315	400	0	-400	0	-400	+400	-400	+200	-200	+200	-200
400	500	0	-450	0	-450	+450	-450	+225	-225	+225	-225
500	630	0	-500	0	-500	+500	-500	—	—	—	—
630	800	0	-750	0	-750	+600	-600	—	—	—	—
800	1 000	0	-1 000	0	-1 000	+750	-750	—	—	—	—
1 000	1 250	0	-1 250	0	-1 250	+900	-900	—	—	—	—
1 250	1 600	0	-1 600	0	-1 600	+1 050	-1 050	—	—	—	—
1 600	2 000	0	-2 000	0	-2 000	+1 200	-1 200	—	—	—	—

5.3.2 Tolerance class 6X

See [Table 15](#).

The diameter tolerances and radial run-out for inner and outer rings of this tolerance class are the same as those given in [Tables 12](#) and [13](#) for the normal class.

Table 15 — Radial tapered roller bearings — Width — Inner rings, outer rings, single-row bearings and single-row subunits — Tolerance class 6X

Limit deviation values in micrometres

d mm		$t_{\Delta Bs}$		$t_{\Delta Cs}$		$t_{\Delta Ts}$ $t_{\Delta TFs}$		$t_{\Delta T1s}$		$t_{\Delta T2s}$ $t_{\Delta TF2s}$	
>	≤	U	L	U	L	U	L	U	L	U	L
—	10	0	-50	0	-100	+100	0	+50	0	+50	0
10	18	0	-50	0	-100	+100	0	+50	0	+50	0
18	30	0	-50	0	-100	+100	0	+50	0	+50	0
30	50	0	-50	0	-100	+100	0	+50	0	+50	0
50	80	0	-50	0	-100	+100	0	+50	0	+50	0
80	120	0	-50	0	-100	+100	0	+50	0	+50	0
120	180	0	-50	0	-100	+150	0	+50	0	+100	0
180	250	0	-50	0	-100	+150	0	+50	0	+100	0
250	315	0	-50	0	-100	+200	0	+100	0	+100	0
315	400	0	-50	0	-100	+200	0	+100	0	+100	0
400	500	0	-50	0	-100	+200	0	+100	0	+100	0

5.3.3 Tolerance class 5

See [Tables 16](#) to [18](#).

Table 16 — Radial tapered roller bearings — Inner ring — Tolerance class 5

Limit deviations and tolerance values in micrometres

<i>d</i> mm		<i>t</i> _{Δdmp}		<i>t</i> _{Vdsp}	<i>t</i> _{Vdmp}	<i>t</i> _{Kia}	<i>t</i> _{Sd}
		U	L				
>	≤						
—	10	0	-7	5	5	5	7
10	18	0	-7	5	5	5	7
18	30	0	-8	6	5	5	8
30	50	0	-10	8	5	6	8
50	80	0	-12	9	6	7	8
80	120	0	-15	11	8	8	9
120	180	0	-18	14	9	11	10
180	250	0	-22	17	11	13	11
250	315	0	-25	19	13	13	13
315	400	0	-30	23	15	15	15
400	500	0	-35	28	17	20	17
500	630	0	-40	35	20	25	20
630	800	0	-50	45	25	30	25
800	1 000	0	-60	60	30	37	30
1 000	1 250	0	-75	75	37	45	40
1 250	1 600	0	-90	90	45	55	50

Table 17 — Radial tapered roller bearings — Outer ring — Tolerance class 5

Limit deviations and tolerance values in micrometres

D mm		$t_{\Delta Dmp}$		t_{VDsp}	t_{VDmp}	t_{Kea}	t_{SD}^{ab} t_{SD1}^b
		U	L				
>	≤	0					
—	18	0	-8	6	5	6	4
18	30	0	-8	6	5	6	4
30	50	0	-9	7	5	7	4
50	80	0	-11	8	6	8	4
80	120	0	-13	10	7	10	4,5
120	150	0	-15	11	8	11	5
150	180	0	-18	14	9	13	5
180	250	0	-20	15	10	15	5,5
250	315	0	-25	19	13	18	6,5
315	400	0	-28	22	14	20	6,5
400	500	0	-33	26	17	24	8,5
500	630	0	-38	30	20	30	10
630	800	0	-45	38	25	36	12,5
800	1 000	0	-60	50	30	43	15
1 000	1 250	0	-80	65	38	52	19
1 250	1 600	0	-100	90	50	62	25
1 600	2 000	0	-125	120	65	73	32,5

NOTE The limit deviations for the outside diameter, D_1 , of an outer ring flange are given in [Table 25](#).

^a Does not apply to bearings with flanged outer ring.

^b Tolerance values have become half the values compared to the previous edition of this International Standard because in this edition, SD and SD1 are defined as perpendicularity of outer ring outside surface axis with respect to datum established from the outer ring face or the outer ring flange back face.

Table 18 — Radial tapered roller bearings — Width — Inner rings, outer rings, single-row bearings and single-row subunits — Tolerance class 5

Limit deviation values in micrometres

<i>d</i> mm		<i>t</i> _{ΔBs}		<i>t</i> _{ΔCs}		<i>t</i> _{ΔTs}		<i>t</i> _{ΔT1s}		<i>t</i> _{ΔT2s}	
						<i>t</i> _{ΔTFs}				<i>t</i> _{ΔTF2s}	
>	≤	U	L	U	L	U	L	U	L	U	L
—	10	0	-200	0	-200	+200	-200	+100	-100	+100	-100
10	18	0	-200	0	-200	+200	-200	+100	-100	+100	-100
18	30	0	-200	0	-200	+200	-200	+100	-100	+100	-100
30	50	0	-240	0	-240	+200	-200	+100	-100	+100	-100
50	80	0	-300	0	-300	+200	-200	+100	-100	+100	-100
80	120	0	-400	0	-400	+200	-200	+100	-100	+100	-100
120	180	0	-500	0	-500	+350	-250	+150	-150	+200	-100
180	250	0	-600	0	-600	+350	-250	+150	-150	+200	-100
250	315	0	-700	0	-700	+350	-250	+150	-150	+200	-100
315	400	0	-800	0	-800	+400	-400	+200	-200	+200	-200
400	500	0	-900	0	-900	+450	-450	+225	-225	+225	-225
500	630	0	-1 100	0	-1 100	+500	-500	—	—	—	—
630	800	0	-1 600	0	-1 600	+600	-600	—	—	—	—
800	1 000	0	-2 000	0	-2 000	+750	-750	—	—	—	—
1 000	1 250	0	-2 000	0	-2 000	+750	-750	—	—	—	—
1 250	1 600	0	-2 000	0	-2 000	+900	-900	—	—	—	—

5.3.4 Tolerance class 4

See [Tables 19](#) to [21](#).**Table 19 — Radial tapered roller bearings — Inner ring — Tolerance class 4**

Limit deviations and tolerance values in micrometres

<i>d</i> mm		<i>t</i> _{Δds}		<i>t</i> _{Vdsp}	<i>t</i> _{Vdmp}	<i>t</i> _{Kia}	<i>t</i> _{Sd}	<i>t</i> _{Sia}
		U	L					
>	≤							
—	10	0	-5	4	4	3	3	3
10	18	0	-5	4	4	3	3	3
18	30	0	-6	5	4	3	4	4
30	50	0	-8	6	5	4	4	4
50	80	0	-9	7	5	4	5	4
80	120	0	-10	8	5	5	5	5
120	180	0	-13	10	7	6	6	7
180	250	0	-15	11	8	8	7	8
250	315	0	-18	12	9	9	8	9

Table 20 — Radial tapered roller bearings — Outer ring — Tolerance class 4

Limit deviations and tolerance values in micrometres

<i>D</i> mm		<i>t</i> _{ΔDs}		<i>t</i> _{VDsp}	<i>t</i> _{VDmp}	<i>t</i> _{Kea}	<i>t</i> _{SD} ^{ab} <i>t</i> _{SD1} ^b	<i>t</i> _{Sea} ^a	<i>t</i> _{Sea1}
		U	L						
>	≤								
—	18	0	-6	5	4	4	2	5	7
18	30	0	-6	5	4	4	2	5	7
30	50	0	-7	5	5	5	2	5	7
50	80	0	-9	7	5	5	2	5	7
80	120	0	-10	8	5	6	2,5	6	8
120	150	0	-11	8	6	7	2,5	7	10
150	180	0	-13	10	7	8	2,5	8	11
180	250	0	-15	11	8	10	3,5	10	14
250	315	0	-18	14	9	11	4	10	14
315	400	0	-20	15	10	13	5	13	18

NOTE The limit deviations for the outside diameter, *D*₁, of an outer ring flange are given in [Table 25](#).

^a Does not apply to bearings with flanged outer ring.

^b Tolerance values have become half the values compared to the previous edition of this International Standard because in this edition, SD and SD1 are defined as perpendicularity of outer ring outside surface axis with respect to datum established from the outer ring face or the outer ring flange back face.

Table 21 — Radial tapered roller bearings — Width — Inner rings, outer rings, single-row bearings and single-row subunits — Tolerance class 4

Limit deviation values in micrometres

d mm		$t_{\Delta Bs}$		$t_{\Delta Cs}$		$t_{\Delta Ts}$ $t_{\Delta TFs}$		$t_{\Delta T1s}$		$t_{\Delta T2s}$ $t_{\Delta TF2s}$	
>	≤	U	L	U	L	U	L	U	L	U	L
—	10	0	-200	0	-200	+200	-200	+100	-100	+100	-100
10	18	0	-200	0	-200	+200	-200	+100	-100	+100	-100
18	30	0	-200	0	-200	+200	-200	+100	-100	+100	-100
30	50	0	-240	0	-240	+200	-200	+100	-100	+100	-100
50	80	0	-300	0	-300	+200	-200	+100	-100	+100	-100
80	120	0	-400	0	-400	+200	-200	+100	-100	+100	-100
120	180	0	-500	0	-500	+350	-250	+150	-150	+200	-100
180	250	0	-600	0	-600	+350	-250	+150	-150	+200	-100
250	315	0	-700	0	-700	+350	-250	+150	-150	+200	-100

5.3.5 Tolerance class 2

See [Tables 22](#) to [24](#).

Table 22 — Radial tapered roller bearings — Inner ring — Tolerance class 2

Limit deviations and tolerance values in micrometres

<i>d</i> mm		<i>t</i> _{Δs}		<i>t</i> _{Vdsp}	<i>t</i> _{Vdmp}	<i>t</i> _{Kia}	<i>t</i> _{Sd}	<i>t</i> _{Sia}
		U	L					
>	≤	U	L					
—	10	0	-4	2,5	1,5	2	1,5	2
10	18	0	-4	2,5	1,5	2	1,5	2
18	30	0	-4	2,5	1,5	2,5	1,5	2,5
30	50	0	-5	3	2	2,5	2	2,5
50	80	0	-5	4	2	3	2	3
80	120	0	-6	5	2,5	3	2,5	3
120	180	0	-7	7	3,5	4	3,5	4
180	250	0	-8	7	4	5	5	5
250	315	0	-8	8	5	6	5,5	6

Table 23 — Radial tapered roller bearings — Outer ring — Tolerance class 2

Limit deviations and tolerance values in micrometres

<i>D</i> mm		<i>t</i> _{ΔDs}		<i>t</i> _{VDsp}	<i>t</i> _{VDmp}	<i>t</i> _{Kea}	<i>t</i> _{SD} ^{ab} <i>t</i> _{SD1} ^b	<i>t</i> _{Sea} ^a	<i>t</i> _{Sea1}
		U	L						
>	≤								
—	18	0	-5	4	2,5	2,5	0,75	2,5	4
18	30	0	-5	4	2,5	2,5	0,75	2,5	4
30	50	0	-5	4	2,5	2,5	1	2,5	4
50	80	0	-6	4	2,5	4	1,25	4	6
80	120	0	-6	5	3	5	1,5	5	7
120	150	0	-7	5	3,5	5	1,75	5	7
150	180	0	-7	7	4	5	2	5	7
180	250	0	-8	8	5	7	2,5	7	10
250	315	0	-9	8	5	7	3	7	10
315	400	0	-10	10	6	8	3,5	8	11

NOTE The limit deviations for the outside diameter, *D*₁, of an outer ring flange are given in [Table 25](#).

^a Does not apply to bearings with flanged outer ring.

^b Tolerance values have become half the values compared to the previous edition of this International Standard because in this edition, SD and SD1 are defined as perpendicularity of outer ring outside surface axis with respect to datum established from the outer ring face or the outer ring flange back face.

Table 24 — Radial tapered roller bearings — Width — Inner rings, outer rings, single-row bearings and single-row subunits — Tolerance class 2

Limit deviation values in micrometres

<i>d</i> mm		<i>t</i> _{ΔBs}		<i>t</i> _{ΔCs}		<i>t</i> _{ΔTs}		<i>t</i> _{ΔT1s}		<i>t</i> _{ΔT2s}	
						<i>t</i> _{ΔTFs}				<i>t</i> _{ΔTF2s}	
>	≤	U	L	U	L	U	L	U	L	U	L
—	10	0	-200	0	-200	+200	-200	+100	-100	+100	-100
10	18	0	-200	0	-200	+200	-200	+100	-100	+100	-100
18	30	0	-200	0	-200	+200	-200	+100	-100	+100	-100
30	50	0	-240	0	-240	+200	-200	+100	-100	+100	-100
50	80	0	-300	0	-300	+200	-200	+100	-100	+100	-100
80	120	0	-400	0	-400	+200	-200	+100	-100	+100	-100
120	180	0	-500	0	-500	+200	-250	+100	-100	+100	-150
180	250	0	-600	0	-600	+200	-300	+100	-150	+100	-150
250	315	0	-700	0	-700	+200	-300	+100	-150	+100	-150

5.4 Radial bearings, outer ring flanges

See [Table 25](#).

Table 25 — Flange outside diameter limit deviations

Limit deviation values in micrometres

D_1 mm		$t_{\Delta D1s}$			
		Locating flange		Non-locating flange	
>	≤	U	L	U	L
—	6	0	-36	+220	-36
6	10	0	-36	+220	-36
10	18	0	-43	+270	-43
18	30	0	-52	+330	-52
30	50	0	-62	+390	-62
50	80	0	-74	+460	-74
80	120	0	-87	+540	-87
120	180	0	-100	+630	-100
180	250	0	-115	+720	-115
250	315	0	-130	+810	-130
315	400	0	-140	+890	-140
400	500	0	-155	+970	-155
500	630	0	-175	+1 100	-175
630	800	0	-200	+1 250	-200
800	1 000	0	-230	+1 400	-230
1 000	1 250	0	-260	+1 650	-260
1 250	1 600	0	-310	+1 950	-310
1 600	2 000	0	-370	+2 300	-370
2 000	2 500	0	-440	+2 800	-440

5.5 Basically tapered bores, tapers 1:12 and 1:30

Tolerances for tapered bores for tolerance class Normal are given in [Tables 26](#) and [27](#).

The tolerances for a tapered bore comprise

- $t_{\Delta dmp}$,
- a taper tolerance, given by limits deviations for taper slope, $t_{\Delta SL}$, and
- t_{Vdsp} .

NOTE See [Figure 7](#).

Table 26 — Tapered bore, taper 1:12

Limit deviations and tolerance values in micrometres

d mm		$t_{\Delta dmp}$		$t_{\Delta SL}$		t_{Vdsp}^{ab}
>	≤	U	L	U	L	
—	10	+22	0	+15	0	9
10	18	+27	0	+18	0	11
18	30	+33	0	+21	0	13
30	50	+39	0	+25	0	16
50	80	+46	0	+30	0	19
80	120	+54	0	+35	0	22
120	180	+63	0	+40	0	40
180	250	+72	0	+46	0	46
250	315	+81	0	+52	0	52
315	400	+89	0	+57	0	57
400	500	+97	0	+63	0	63
500	630	+110	0	+70	0	70
630	800	+125	0	+80	0	—
800	1 000	+140	0	+90	0	—
1 000	1 250	+165	0	+105	0	—
1 250	1 600	+195	0	+125	0	—

^a Applies in any cross-section of the bore.
^b Does not apply to diameter series 7 and 8.

Table 27 — Tapered bore, taper 1:30

Limit deviations and tolerance values in micrometres

d mm		$t_{\Delta dmp}$		$t_{\Delta SL}$		t_{Vdsp}^{ab}
>	≤	U	L	U	L	
—	50	+15	0	+30	0	19
50	80	+15	0	+30	0	19
80	120	+20	0	+35	0	22
120	180	+25	0	+40	0	40
180	250	+30	0	+46	0	46
250	315	+35	0	+52	0	52
315	400	+40	0	+57	0	57
400	500	+45	0	+63	0	63
500	630	+50	0	+70	0	70
^a Applies in any cross-section of the bore. ^b Does not apply to diameter series 7 and 8.						

Annex A (informative)

Symbols and terms as given in ISO 492:2002 in relation to descriptions given in this International Standard

Table A.1 — Description of symbols

Symbol for nominal dimension (size and distance)	Symbol for characteristic	Term as given in ISO 492:2002	Description given in this International Standard
B		Nominal inner ring width	Nominal inner ring width
	VBs	Variation of inner ring width	<p>Symmetrical rings: range of two-point sizes of inner ring width</p> <p>Asymmetrical rings: range of minimum circumscribed sizes of inner ring width between two opposite lines, obtained from any longitudinal section which includes the inner ring bore</p>
	ΔBs	Deviation of a single inner ring width	<p>Symmetrical rings: deviation of a two-point size of inner ring width from its nominal size</p>
			<p>Asymmetrical rings, upper limit: deviation of a minimum circumscribed size of inner ring width, between two opposite lines, in any longitudinal section which includes the inner ring bore axis, from its nominal size</p>
			<p>Asymmetrical rings, lower limit: deviation of two-point size of inner ring width from its nominal size</p>
C		Nominal outer ring width	Nominal outer ring width
	VCS	Variation of outer ring width	<p>Symmetrical rings: range of two-point sizes of outer ring width</p> <p>Asymmetrical rings: range of minimum circumscribed sizes of outer ring width between two opposite lines, obtained from any longitudinal section which includes the outer ring outside surface axis</p>
	ΔCs	Deviation of a single outer ring width	<p>Symmetrical rings: deviation of a two-point size of outer ring width from its nominal size</p>
			<p>Asymmetrical rings, upper limit: deviation of a minimum circumscribed size of outer ring width between two opposite lines, in any longitudinal section which includes the outer ring outside surface axis, from its nominal size</p>
			<p>Asymmetrical rings, lower limit: deviation of a two-point size of outer ring width from its nominal size</p>

Table A.1 — (continued)

Symbol for nominal dimension (size and distance)	Symbol for characteristic	Term as given in the previous edition of this International Standard (ISO 492:2002)	Description given in this International Standard
C_1		Nominal outer ring flange width	Nominal outer ring flange width
	VC1s	Variation of outer ring flange width	Range of two-point sizes of outer ring flange width
	$\Delta C1s$	Deviation of a single outer ring flange width	Deviation of a two-point size of outer ring flange width from its nominal size
d		Nominal bore diameter	Nominal bore diameter of a cylindrical bore or at the theoretical small end of a tapered bore
	Vdmp	Variation of mean bore diameter	Range of mid-range sizes (out of two-point sizes) of bore diameter obtained from any cross-section of a cylindrical bore
	Δdmp	Deviation of mean bore diameter in a single plane	Cylindrical bore: deviation of a mid-range size (out of two-point sizes) of bore diameter in any cross-section from its nominal size
		Deviation of mean bore diameter in a single plane at the theoretical small end of the bore	Tapered bore: deviation of a mid-range size (out of two-point sizes) of bore diameter at the theoretical small end from its nominal size
	Vdsp	Variation of bore diameter in a single plane	Range of two-point sizes of bore diameter in any cross-section of a cylindrical or tapered bore
	Δds	Deviation of a single bore diameter	Deviation of a two-point size of bore diameter of a cylindrical bore from its nominal size
d_1		Diameter at the theoretical large end of a basically tapered bore	Nominal diameter at the theoretical large end of a tapered bore
	$\Delta d1mp$	Deviation of mean bore diameter in a single plane at the theoretical large end of a basically tapered bore	Deviation of a mid-range size (out of two-point sizes) of bore diameter at the theoretical large end of a tapered bore from its nominal size
D		Nominal outside diameter	Nominal outside diameter
	VDmp	Variation of mean outside diameter	Range of mid-range size (out of two-point sizes) of outside diameter obtained from any cross-section
	ΔDmp	Deviation of mean outside diameter in a single plane	Deviation of a mid-range size (out of two-point sizes) of outside diameter in any cross-section from its nominal size
	VDsp	Variation of outside diameter in a single plane	Range of two-point sizes of outside diameter in any cross-section
	ΔDs	Deviation of a single outside diameter	Deviation of a two-point size of outside diameter from its nominal size

Table A.1 — (continued)

Symbol for nominal dimension (size and distance)	Symbol for characteristic	Term as given in ISO 492:2002	Description given in this International Standard
D_1		Nominal outside diameter of outer ring flange	Nominal outside diameter of outer ring flange
	$\Delta D1s$	Deviation of a single outside diameter of outer ring flange	Deviation of a two-point size of outside diameter of outer ring flange from its nominal size
	Kea	Radial run-out of outer ring of assembled bearing	Circular radial run-out of outer ring outside surface of assembled bearing with respect to datum, i.e. axis, established from the inner ring bore surface
	Kia	Radial run-out of inner ring of assembled bearing	Circular radial run-out of inner ring bore surface of assembled bearing with respect to datum, i.e. axis, established from the outer ring outside surface
	Sd	Perpendicularity of inner ring face with respect to the bore	Circular axial run-out of inner ring face with respect to datum, i.e. axis, established from the inner ring bore surface
	SD	Perpendicularity of outer ring outside surface with respect to the face	Perpendicularity of outer ring outside surface axis with respect to datum established from the outer ring face
	SD1	Perpendicularity of outer ring outside surface axis with respect to the flange back face	Perpendicularity of outer ring outside surface axis with respect to datum established from the outer ring flange back face
	Sea	Axial run-out of outer ring of assembled bearing	Circular axial run-out of outer ring face of assembled bearing with respect to datum, i.e. axis, established from the inner ring bore surface
	Sea1	Axial run-out of outer ring flange back face of assembled bearing	Circular axial run-out of outer ring flange back face of assembled bearing with respect to datum, i.e. axis, established from the inner ring bore surface
	Sia	Axial run-out of inner ring of assembled bearing	Circular axial run-out of inner ring face of assembled bearing with respect to datum, i.e. axis, established from the outer ring outside surface
SL		—	Taper slope is the difference between nominal diameters at the theoretical large end and small end of a tapered bore ($d_1 - d$)
	ΔSL	—	Deviation of taper slope of a tapered inner ring bore from its nominal size

Table A.1 — (continued)

Symbol for nominal dimension (size and distance)	Symbol for characteristic	Term as given in the previous edition of this International Standard (ISO 492:2002)	Description given in this International Standard
T		Assembled bearing width	Nominal assembled bearing width
	ΔT_s	Deviation of the actual (assembled) bearing width	Deviation of minimum circumscribed size of assembled bearing width from its nominal size
T_1		Effective width of inner subunit assembled with a master outer ring	Nominal effective width of inner subunit assembled with a master outer ring
	ΔT_{1s}	Deviation of the actual effective width of inner subunit assembled with a master outer ring	Deviation of minimum circumscribed size of effective width (inner subunit assembled with a master outer ring) from its nominal size
T_2		Effective width of outer ring assembled with a master inner subunit	Nominal effective width of outer ring assembled with a master inner subunit
	ΔT_{2s}	Deviation of the actual effective width of outer ring assembled with a master inner subunit	Deviation of minimum circumscribed size of effective width (outer ring assembled with a master inner subunit) from its nominal size
T_F		—	Nominal assembled flanged bearing width
	ΔT_{Fs}	—	Deviation of minimum circumscribed size of assembled flange bearing width from its nominal size
T_{F2}		—	Nominal effective width of flanged outer ring assembled with a master inner subunit
	ΔT_{F2s}	—	Deviation of minimum circumscribed size of effective width (flanged outer ring assembled with a master inner subunit) from its nominal size
α		Angle of taper (half the cone angle) of inner ring bore	Frustum angle of tapered inner ring bore
a		—	Distance from face to define the restricted area for SD or SD1

Annex B (informative)

Example of drawing indications of characteristics with specification for radial bearings

Figure B.1 gives an example of drawing indications of the characteristics given in this International Standard.

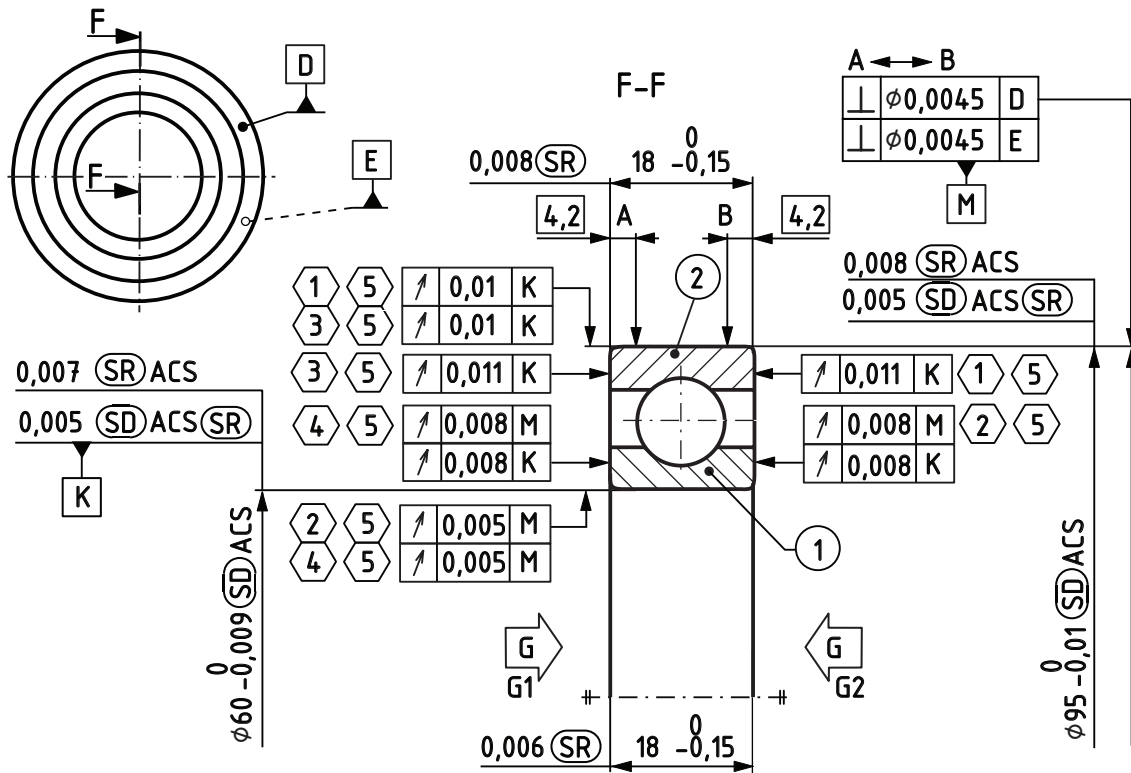

① ≡ FP (1) - MP (2), G2

② ≡ FP (2) - MP (1), G2

③ ≡ FP (1) - MP (2), G1

④ ≡ FP (2) - MP (1), G1

⑤ ≡ the rolling elements shall be in contact with both the inner and outer ring raceways

NOTE 1 Specification modifier (LP) is usually not indicated, because two-point size is the default specification for size.

NOTE 2 The dimensions and tolerance values correspond to a radial ball bearing according to dimension series 10, bore diameter 60, and tolerance class 5.

Figure B.1 — Example of drawing

Figure B.2 gives an example of drawing indications where tolerances are only indicated on main dimensions. For other tolerances, a reference to this International Standard and the relevant tolerance class is given.

All associated specification modifiers need to be indicated as well.

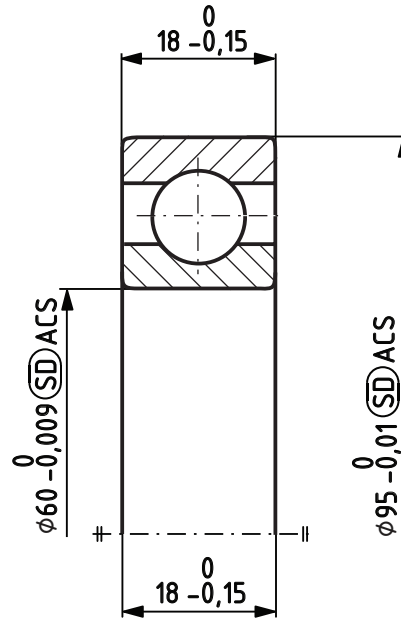

Other tolerances in accordance with ISO 492 - Tolerance class 5.

Figure B.2 — Example of drawing indications together with a specified tolerance class and standard reference

Annex C (informative)

Illustration of ISO 1132-1 and ISO 14405-1 terms and definitions

C.1 General

Due to the alignment with geometrical product specifications (GPS), the terms and definitions of some tolerance characteristics have been changed. This is obvious if the terms and definitions of ISO 1132-1^[4] (which were the basis of previous editions of ISO 492) and the terms and definitions of ISO/GPS standards are compared.

This Annex illustrates the differences in terms of some characteristics.

C.2 Single bore diameter versus two-point diameter

C.2.1 Single bore diameter according to ISO 1132-1

For graphical representation, see [Figures C.1](#) and [C.2](#).

C.2.1.1 single bore diameter

d_s
distance between two parallel tangents to the line of intersection of the actual bore surface and any radial plane

[SOURCE: ISO 1132-1:2000, 5.1.2]

C.2.1.2 radial plane

plane perpendicular to an axis

Note 1 to entry: For a bearing ring, it is generally acceptable to consider a radial plane as being parallel with the plane tangential to the reference face of the ring.

[SOURCE: ISO 1132-1:2000, 4.5]

C.2.1.3 inner ring axis

axis of the cylinder or cone inscribed in the basically cylindrical or tapered bore of an inner ring

[SOURCE: ISO 1132-1:2000, 4.2]

C.2.2 Two-point diameter according to ISO 14405-1 and ISO 14660-2

For graphical representation, see [Figure C.3](#).

C.2.2.1 Terms and definitions according to ISO 14405-1

C.2.2.1.1

two-point size

<local size> distance between two opposite points taken on the feature of size

Note 1 to entry: A two-point size taken on cylinder can be called a “two-point diameter”. In ISO 14660-2^[13] this is defined as a local diameter of an extracted cylinder.

Note 2 to entry: A two-point size taken on two opposite planes can be called a “two-point distance”. In ISO 14660-2^[13] this is defined as a local size of two parallel extracted surfaces.

[SOURCE: ISO 14405-1:2010, 3.10.1]

C.2.2.2 Terms and definitions according to ISO 14660-2

C.2.2.2.1

local size of an extracted cylinder

local diameter of an extracted cylinder

distance between two opposite points on the feature, where

- the connection line between the points includes the associated circle centre, and
- the cross-sections are perpendicular to the axis of the associated cylinder obtained from the extracted surface

[SOURCE: ISO 14660-2:1999, 3.5]

C.2.2.2.2

extracted median line of a cylinder

locus of centres of cross-sections, where

- the centres of cross-sections are centres of associated circles, and
- the cross-sections are perpendicular to the axis of the associated cylinder obtained from the extracted surface (i.e. the radius could be different from the nominal radius)

[SOURCE: ISO 14660-2:1999, 3.2]

C.2.2.2.3

extracted median line of a cylinder

For the default definition (unless otherwise specified) of the extracted median line of a cylinder, the following conditions apply:

- the associated circles are the total least squares circles;
- the associated cylinder is the total least squares cylinder

[SOURCE: ISO 14660-2:1999, 4.1.1]

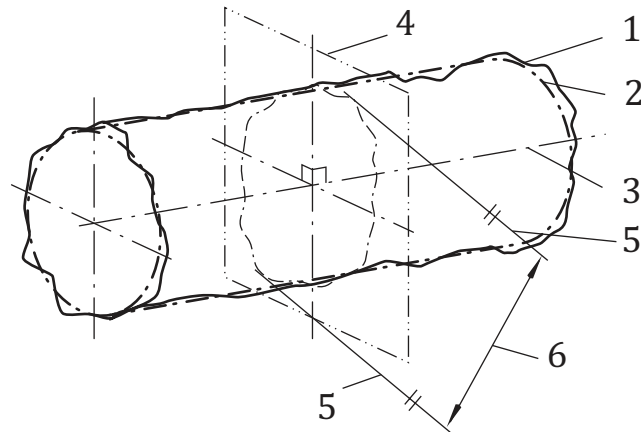

Key

- 1 actual bore surface (ISO 17450-1[14] real integral surface)
- 2 cylinder inscribed in the basically cylindrical bore (ISO 17450-1[14] associated integral cylinder)
- 3 axis of the cylinder inscribed in the basically cylindrical bore (ISO 17450-1[14] associated derived axis)
- 4 plane perpendicular to the axis
- 5 two parallel tangents to the line of intersection of the actual bore surface and any radial plane
- 6 single bore diameter

Figure C.1 — Single bore diameter

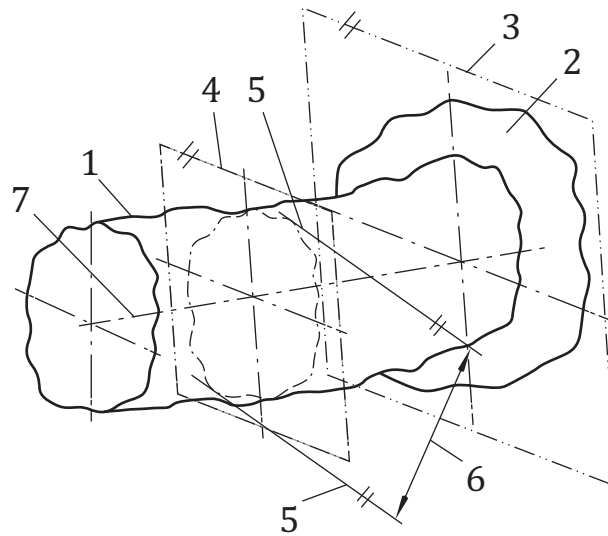
**Key**

- 1 actual bore surface (ISO 17450-1[14] real integral surface)
- 2 actual reference face of the inner ring (ISO 17450-1[14] real integral surface)
- 3 plane tangential to the actual reference face of the inner ring
- 4 plane parallel with the plane tangential to the actual reference face of the inner ring
- 5 two parallel tangents to the line of intersection of the actual bore surface and a plane parallel with the plane tangential to the actual reference face of the inner ring
- 6 single bore diameter
- 7 axis of the cylinder inscribed in the basically cylindrical bore (ISO 17450-1[14] associated derived axis) which is not perpendicular to the plane tangential to the reference face of the inner ring

Figure C.2 — Single bore diameter with radial plane parallel with a plane tangential to the reference face of the inner ring

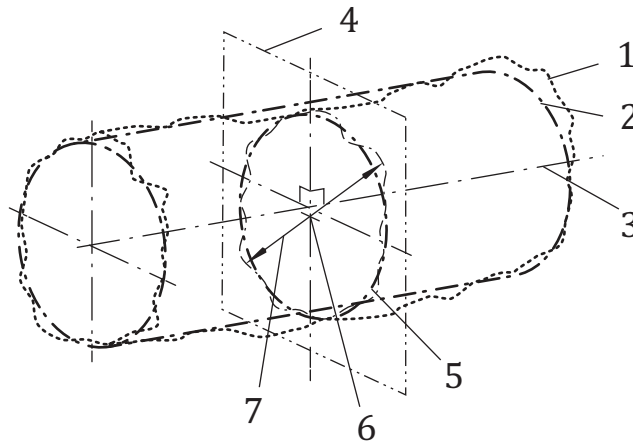

Key

- 1 extracted bore surface
- 2 associated cylinder (total least-squares cylinder)
- 3 associated cylinder axis
- 4 plane perpendicular to the associated axis
- 5 associated circle (total least-squares circle)
- 6 associated circle centre
- 7 example of a two-point diameter

Figure C.3 — Two-point diameter

C.3 Single ring width versus two-point distance

C.3.1 Single ring width according to ISO 1132-1[4]

For graphical representation, see [Figure C.4](#).

C.3.1.1

single ring width

B_s or C_s

distance between the points of intersection of the two actual side faces of a ring and a straight line perpendicular to the plane tangential to the reference face of the ring

[SOURCE: ISO 1132-1:2000[4], 5.3.2]

C.3.1.2

reference face of a ring

face of a ring designated as the reference face by the manufacturer of the bearing and which may be the datum for measurements

Note 1 to entry: For bearings designed to support axial loads, this is generally the back face.

[SOURCE:ISO 1132-1:2000[4], 4.4]

C.3.2 Two-point distance according to ISO 14405-1 and ISO 14660-2[13]

C.3.2.1 Terms and definitions according to ISO 14405-1

For graphical representation, see [Figure C.5](#).

C.3.2.1.1

two-point size

<local size> distance between two opposite points taken on the feature of size

Note 1 to entry: A two-point size taken on cylinder can be called a “two-point diameter”. In ISO 14660-2[13], this is defined as a local diameter of an extracted cylinder.

Note 2 to entry: A two-point size taken on two opposite planes can be called “two-point distance”. In ISO 14660-2 [13], this is defined as a local size of two parallel extracted surfaces.

[SOURCE: ISO 14405-1:2010, 3.10.1]

C.3.2.2 Terms and definitions according to ISO 14660-2[13]

C.3.2.2.1

local size of two parallel extracted surfaces

distance between two points on opposite extracted surfaces, where

- the connecting lines of sets of opposite points are perpendicular to the associated median plane, and
- the associated median plane is the median plane of two associated parallel planes obtained from the extracted surfaces (i.e. the distance between the two associated parallel planes could be different from the nominal distance)

[SOURCE: ISO 14660-2:1999, 3.6]

C.3.2.2.2

extracted median surface

locus of centrepoinTs between sets of opposite points of the opposite extracted surfaces, where

- the connecting lines of sets of opposite points are perpendicular to the associated median plane; and
- the associated median plane is the median plane of two associated parallel planes obtained from the extracted surfaces (i.e. the distance between the two associated parallel planes could be different from the nominal distance)

[SOURCE: ISO 14660-2:1999, 3.4]

C.3.2.2.3

extracted median surface

For the default definition (unless otherwise specified) of the extracted median surface, the following condition applies:

- the two associated parallel planes are obtained by the total least squares method

[SOURCE: ISO 14660-2:1999, 4.1.3]

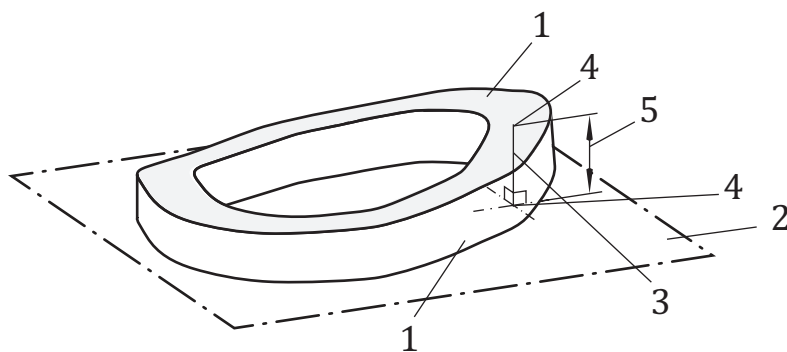

Key

- 1 actual side face (ISO 17450-1[14] real integral surface)
- 2 plane tangential to the reference face (ISO 17450-1[14] associated plane)
- 3 straight line perpendicular to the plane tangential to the reference face of the ring
- 4 points of intersection of the two actual side faces of a ring and a straight line perpendicular to the plane tangential to the reference face of the ring
- 5 single ring width

Figure C.4 — Single ring width

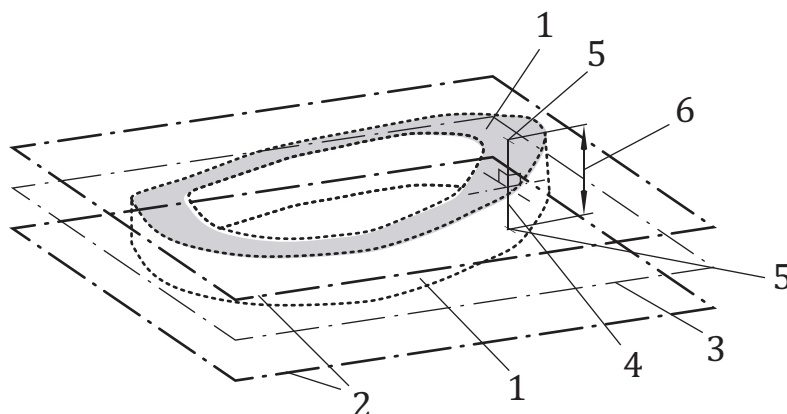

Key

- 1 extracted surface
- 2 associated plane (total least-squares method)
- 3 associated median plane
- 4 connecting lines of sets of opposite points perpendicular to the associated median plane
- 5 points of intersection of the two extracted surfaces and the connection line
- 6 two-point distance

Figure C.5 — Two-point distance

Annex D (informative)

Description with illustrations for specification modifiers of linear sizes

D.1 General

The symbols for specification modifiers of linear sizes used in this International Standard are specified in ISO 14405-1. This Annex mentions the descriptions with illustrations as terms and definitions of symbols for specification modifiers given in ISO 14405-1.

D.2 Specification modifiers and symbols



[Table D.1](#) shows symbols for specification modifiers for linear sizes. These definitions are given in [D.3](#) and [D.4](#). [Table D.2](#) shows combinations of symbols for specification modifiers. These descriptions are mentioned in [D.5](#).

Table D.1 — Specification modifiers for linear sizes

Symbol for specification modifier	Term	ISO 14405-1:2010 clause	Description with illustration
(LP)	Two-point size	3.10.1	Figure D.1
(SD)	Mid-range size	3.11.2.2.5	—
(SR)	Range of size	3.11.2.2.6	—
(GN)	Minimum circumscribed size	3.11.1.3	Figure D.2
ACS	Any cross-section	7.4	Figure D.3
SCS	Specific fixed cross-section	7.5	Figure D.4
ALS  ^a	Any longitudinal section constructed by an intersection plane	—	Figure D.5

^a Symbol for datum to be indicated.

Table D.2 — Combination of symbols for specification modifiers

Combination of symbols for specification modifier	Symbol for characteristic	Description according to Table 1	Description with illustration
	VDmp	Range of mid-range sizes (out of two-point sizes) of outside diameter obtain from any cross-section	Figure D.6
	Vdmp	Range of mid-range sizes (out of two-point sizes) of bore diameter obtained from any cross-section of a cylindrical bore	
	VBs	Asymmetrical rings: range of minimum circumscribed sizes of inner ring width, obtained from any longitudinal section which includes the inner ring bore axis	Figure D.7
	VCs	Asymmetrical rings: range of minimum circumscribed sizes of outer ring width, between two opposite lines, in any longitudinal section which includes the outer ring outside surface axis	
^a Symbol for datum to be indicated.			

D.3 Terms, definitions and modifiers specified in ISO 14405-1 and descriptions with illustrations

The following shows the terms and definitions of specification modifiers and description of general specification modifier specified in ISO 14405-1, together with the illustrations for the descriptions of specification modifiers.

D.3.1 specification modifier

GPS specification element that changes the default definition of the basic GPS specification when applied

Note 1 to entry: Specification modifiers may be defined by International Standards, national standards or company standards/documents

[SOURCE: ISO 14405-1:2010, 3.1]

D.3.2 feature of size

geometrical shape defined by a linear or angular dimension which is a *size* (D.3.3)

Note 1 to entry: The features of size can be a cylinder, a sphere, two parallel opposite surfaces, a cone, or a wedge.

Note 2 to entry: In International Standards such as ISO 286-1[1] and ISO 1938-1,[6] the meanings of the terms “plain workpiece” and “single features” are close to that of “feature of size”.

[SOURCE: ISO 14405-1:2010, 3.2, modified – Note 3 omitted]

D.3.3 size

intrinsic characteristic of a *feature of size* (D.3.2) that can be defined on a nominal feature or on an associated feature

Note 1 to entry: In ISO 14405-1, the size corresponds to the diameter of a cylinder, or to the distance between two parallel opposite planes. Depending on the type of feature of size, the terms “diameter” and “distance” are synonyms for size.

[SOURCE: ISO 14405-1:2010, 3.8, modified — Note 2 omitted]

D.3.4

size characteristic

characteristic relative to a *size* (D.3.3) and defined on an extracted feature

Note 1 to entry: A size can be evaluated by more than one size characteristic (e.g. the two-point diameter or the diameter of the associated feature, taken on the extracted feature).

[SOURCE: ISO 14405-1:2010, 3.9]

D.3.5

local size

size characteristic (D.3.4) having by definition a non-unique result of evaluation along and/or around the *feature of size* (D.3.2)

Note 1 to entry: For a given feature, an infinity of local sizes exists.

Note 2 to entry: In ISO 14405-1, “local size” is used instead of “local linear size”.

[SOURCE: ISO 14405-1:2010, 3.10, modified — Alternative terms and Note 3 omitted]

D.3.6

two-point size

<local size> distance between two opposite points taken on the *feature of size* (D.3.2)

Note 1 to entry: A two-point size taken on cylinder can be called a “two-point diameter”. In ISO 14660-2,^[13] this is defined as a local diameter of an extracted cylinder.

Note 2 to entry: A two-point size taken on two opposite planes can be called a “two-point distance”. In ISO 14660-2,^[13] this is defined as a *local size* (D.3.5) of two parallel extracted surfaces.

[SOURCE: ISO 14405-1:2010, 3.10.1]

See [Figure D.1](#).

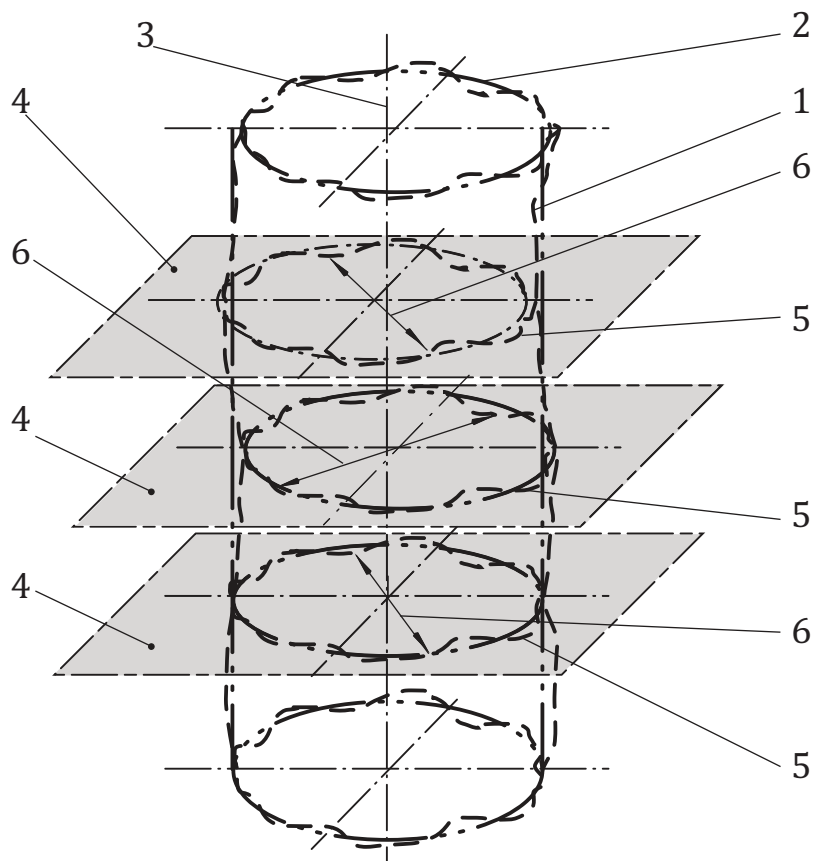

Key

- 1 extracted cylinder
- 2 associated cylinder
- 3 associated cylinder axis
- 4 any one of an infinite number of planes perpendicular to the associated axis
- 5 extracted circle
- 6 two-point size (diameter)

NOTE Three cross-sections are shown, but analogous to Note 1 to entry in D.3.5, infinity of cross-sections exists.

Figure D.1 — Two-point size

D.3.7

rank-order size

size characteristic (D.3.4) defined mathematically from a homogeneous set of *local size* (D.3.5) values obtained along and/or around the tolerated feature

Note 1 to entry: A rank-order size can be used to define an indirect global size (ISO 14405-1:2010, 3.11.2) (for example an average of a set of two-point size values taken on the extracted cylindrical surface) from a local size [*two-point size* (D.3.6)].

Note 2 to entry: A rank-order size can be used to define a local size from another local size (for example to define a rank-order section size from a two-point size taken in the section).

[SOURCE: ISO 14405-1:2010, 3.11.2.2 — Note 1 modified and Note 3 omitted]

D.3.8**mid-range size**

rank-order size (D.3.7) defined as the mean of the maximum and the minimum of the set of values of a *local size* (D.3.5) along and/or around the tolerated feature

[SOURCE: ISO 14405-1:2010, 3.11.2.2.5]

The specification of range of size should be indicated on the drawing with the modifier **(SD)**.

D.3.9**range of sizes**

rank-order size (D.3.7) defined as the difference between the maximum and the minimum of the set of values of a *local size* (D.3.5) along and/or around the tolerated feature

[SOURCE: ISO 14405-1:2010, 3.11.2.2.6]

The specification of range of size should be indicated on the drawing with the modifier **(SR)**.

D.3.10**minimum circumscribed size**

<global size> *size* (D.3.3) of the associated feature established from the extracted feature(s) with the minimum circumscribed criterion

Note 1 to entry: In the case of an external feature of size, the minimum circumscribed size was previously called “mating size for an external feature”.

[SOURCE: ISO 14405-1:2010, 3.11.1.3]

See [Figure D.2](#).

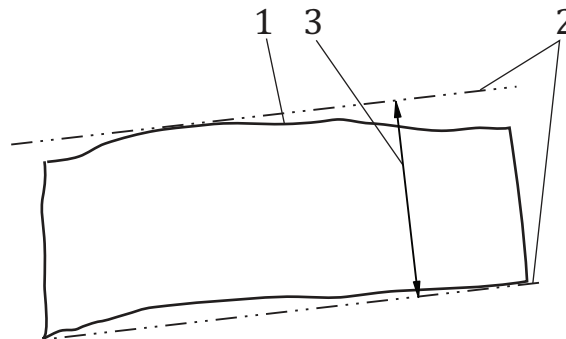
**Key**

- 1 an extracted feature
- 2 parallel planes or parallel lines
- 3 minimum distance between parallel planes or parallel lines

Figure D.2 — Minimum circumscribed size

D.3.11

any cross-section of a feature of size (ACS)

If the specification applies to any cross-section of either the complete feature of size or a fixed restricted portion of it, it should be indicated with the specification modifier “ACS”, or the cross-section should be toleranced and indicated on the drawing and the specification modifier “ACS” should be added to that tolerance; moreover, if any cross-sections are taken on a restricted portion of the complete feature of size, then the restricted portion should be indicated by using a long-dashed dotted wide line or by using the “between” symbol for the extension of an application for a restricted portion.

[SOURCE: ISO 14405-1:2010, 7.4, modified — shortened text.]

See [Figure D.3](#).

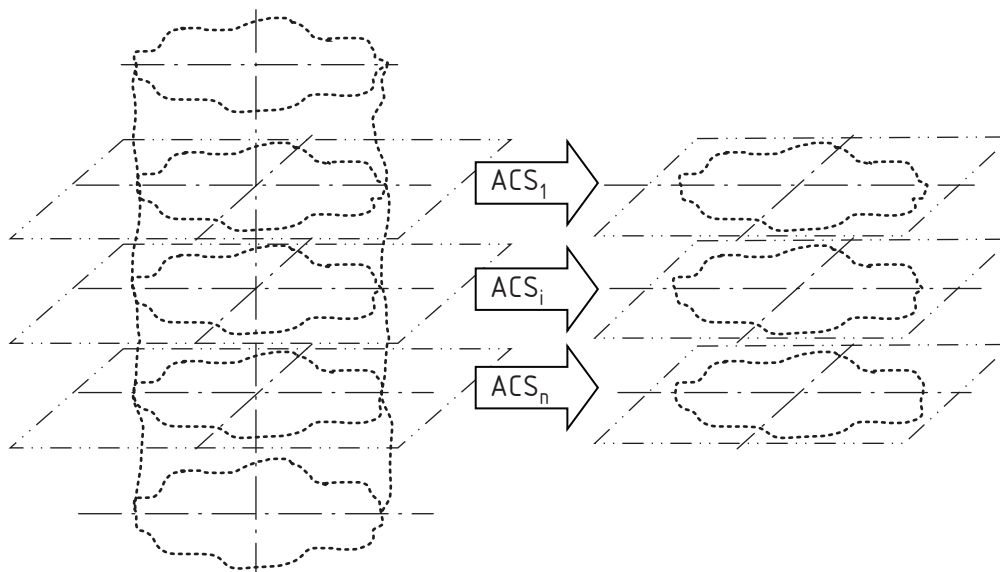

NOTE Three cross-sections are shown, but analogous to D.3.5 Note 1 to entry, infinity of cross-sections exists.

Figure D.3 — Any cross-section (ACS)

D.3.12

Specific cross-section of a feature of size (SCS)

If the specification applies to one defined cross-section of the complete feature of size (D.3.2), the cross-section should be placed in the feature by a dimension and the specification should be indicated in the cross-section on the drawing and the modifier “SCS” should be indicated; when no confusion about the nature of the specific cross-section is possible, the symbol “SCS” can be omitted.

[SOURCE: ISO 14405-1:2010, 7.5, modified — shortened text.]

See [Figure D.4](#).

Key

- 1 SCS (specific fixed cross-section) at theoretical small end of a tapered bore
- 2 SCS (specific fixed cross-section) at theoretical large end of a tapered bore

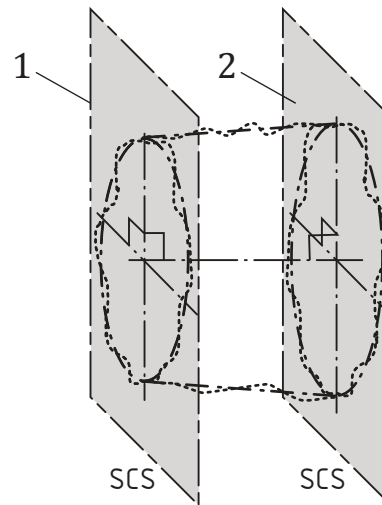

Figure D.4 — Specific cross-section (SCS)

D.4 Additional terms and descriptions with illustrations

D.4.1 Any longitudinal section of a feature of size (ALS)

If the specification applies to any longitudinal section of the complete *feature of size* (D.3.2), it shall be indicated with the specification modifier “ALS”.

See [Figure D.5](#).

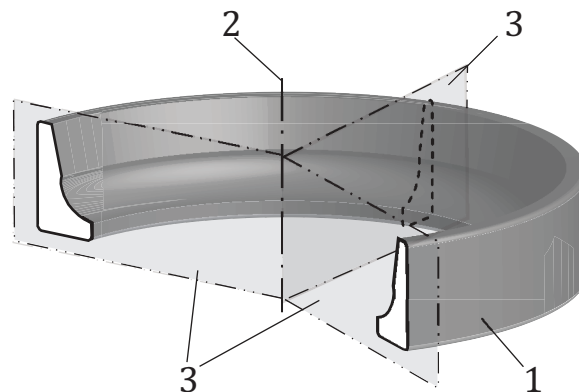

Key

- 1 associated cylinder
- 2 associated cylinder axis
- 3 ALS (any longitudinal section) which includes the outside surface axis

NOTE Three longitudinal sections are shown, but infinity of longitudinal sections exist.

Figure D.5 — Any longitudinal section (ALS)

D.5 Combination of symbols for specification modifiers

D.5.1 General

Symbols for specification modifiers are often used in combination. The following subclauses show descriptions of the combinations of specification modifiers specified in ISO 14405-1, together with the illustrations for the descriptions of the combinations of specification modifiers.

D.5.2 Example of symbol combination: $\textcircled{\text{LP}} \textcircled{\text{SD}} \text{ACS} \textcircled{\text{SR}}$

For example, “VDmp” is described in [Figure D.6](#).

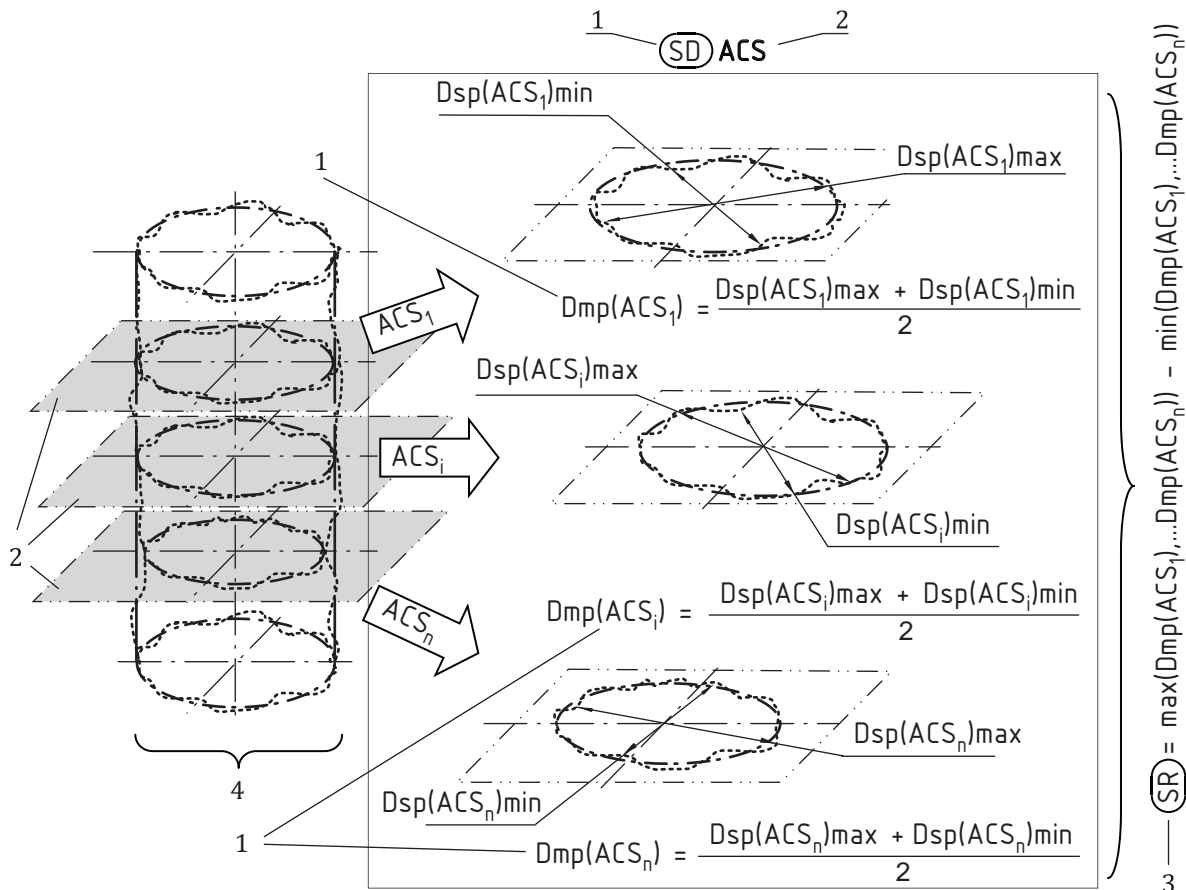

Key

- 1 mean of the maximum and minimum of the set of \emptyset Dsp values in an ACS
- 2 any cross-section
- 3 the difference between the maximum and minimum of the set of Dmp values
- 4 see [Figure D.1](#)

NOTE Three cross-sections are shown, but analogous to D.3.5 Note 1 to entry, infinity of cross-sections exists.

Figure D.6 — Combination of symbols, $\textcircled{\text{LP}} \textcircled{\text{SD}} \text{ACS} \textcircled{\text{SR}}$

D.5.3 Example of symbol combination: $\textcircled{\text{GN}} \text{ALS} \textcircled{\text{SR}} \textcircled{\text{M}}$

For example, “VCs” for asymmetrical rings is described in [Figure D.7](#).

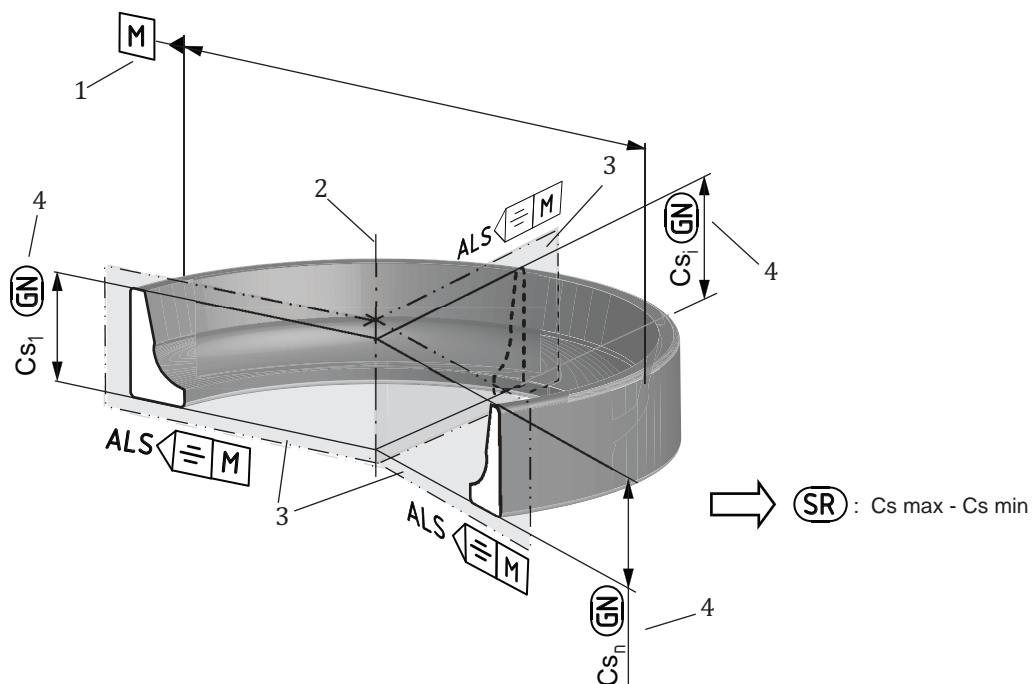

Key

- 1 datum feature indication
- 2 associated cylinder axis (datum M)
- 3 ALS (any longitudinal section), including associated cylinder axis (datum M)
- 4 minimum circumscribed size of outer ring width in ALS

NOTE Three longitudinal sections are shown, but infinity of longitudinal sections exists.

Figure D.7 — Combination of symbols, $\text{GN ALS SR} \leftarrow \text{M}$

Bibliography

- [1] ISO 286-1, *Geometrical product specifications (GPS) — ISO code system for tolerances on linear sizes — Part 1: Basis of tolerances, deviations and fits*
- [2] ISO 355, *Rolling bearings — Tapered roller bearings — Boundary dimensions and series designations*
- [3] ISO 1119, *Geometrical product specifications (GPS) — Series of conical tapers and taper angles*
- [4] ISO 1132-1, *Rolling bearings — Tolerances — Part 1: Terms and definitions*
- [5] ISO 1132-2, *Rolling bearings — Tolerances — Part 2: Measuring and gauging principles and methods*
- [6] ISO 1938-1:—¹⁾, *Geometrical product specifications (GPS) — Dimensional measuring equipment — Part 1: Plain limit gauges of linear size*
- [7] ISO 5459, *Geometrical product specifications (GPS) — Geometrical tolerancing — Datums and datum systems*
- [8] ISO 8015, *Geometrical product specifications (GPS) — Fundamentals — Concepts, principles and rules*
- [9] ISO 8443, *Rolling bearings — Radial ball bearings with flanged outer ring — Flange dimensions*
- [10] ISO 14253-1, *Geometrical product specifications (GPS) — Inspection by measurement of workpieces and measuring equipment — Part 1: Decision rules for proving conformity or nonconformity with specifications*
- [11] ISO 14253-2, *Geometrical product specifications (GPS) — Inspection by measurement of workpieces and measuring equipment — Part 2: Guidance for the estimation of uncertainty in GPS measurement, in calibration of measuring equipment and in product verification*
- [12] ISO/TR 14638, *Geometrical product specification (GPS) — Masterplan*
- [13] ISO 14660-2, *Geometrical Product Specifications (GPS) — Geometrical features — Part 2: Extracted median line of a cylinder and a cone, extracted median surface, local size of an extracted feature*
- [14] ISO 17450-1, *Geometrical product specifications (GPS) — General concepts — Part 1: Model for geometrical specification and verification*
- [15] ISO 15241, *Rolling bearings — Symbols for physical quantities*

1) To be published.

