

Third edition  
2013-07-01

Corrected version  
2015-06-01

---

---

**Steel and steel products — Location  
and preparation of samples and test  
pieces for mechanical testing**

*Acier et produits en acier — Position et préparation des échantillons  
et éprouvettes pour essais mécaniques*



Reference number  
ISO 377:2013(E)

© ISO 2013



**COPYRIGHT PROTECTED DOCUMENT**

© ISO 2013, Published in Switzerland

All rights reserved. Unless otherwise specified, no part of this publication may be reproduced or utilized otherwise in any form or by any means, electronic or mechanical, including photocopying, or posting on the internet or an intranet, without prior written permission. Permission can be requested from either ISO at the address below or ISO's member body in the country of the requester.

ISO copyright office  
Ch. de Blandonnet 8 • CP 401  
CH-1214 Vernier, Geneva, Switzerland  
Tel. +41 22 749 01 11  
Fax +41 22 749 09 47  
copyright@iso.org  
www.iso.org

# Contents

	Page
Foreword .....	iv
<b>1 Scope</b> .....	<b>1</b>
<b>2 Normative references</b> .....	<b>1</b>
<b>3 Terms and definitions</b> .....	<b>1</b>
<b>4 General requirements</b> .....	<b>2</b>
4.1 Representative testing .....	2
4.2 Identification of sample products, samples, rough specimens and test pieces .....	2
<b>5 Preparation of samples and selection of test pieces</b> .....	<b>3</b>
5.1 Selection and dimensions of samples and location of test pieces .....	3
5.2 Direction of axis of test pieces .....	3
5.3 Condition and separation of samples .....	4
5.3.1 General .....	4
5.3.2 Testing in the as-delivered condition .....	4
5.3.3 Testing in the reference condition .....	4
<b>6 Preparation of test pieces</b> .....	<b>4</b>
6.1 Cutting and machining .....	4
6.2 Reference heat treatment .....	5
<b>Annex A (normative) Location of samples and test pieces</b> .....	<b>6</b>

## Foreword

ISO (the International Organization for Standardization) is a worldwide federation of national standards bodies (ISO member bodies). The work of preparing International Standards is normally carried out through ISO technical committees. Each member body interested in a subject for which a technical committee has been established has the right to be represented on that committee. International organizations, governmental and non-governmental, in liaison with ISO, also take part in the work. ISO collaborates closely with the International Electrotechnical Commission (IEC) on all matters of electrotechnical standardization.

The procedures used to develop this document and those intended for its further maintenance are described in the ISO/IEC Directives, Part 1. In particular the different approval criteria needed for the different types of ISO documents should be noted. This document was drafted in accordance with the editorial rules of the ISO/IEC Directives, Part 2. [www.iso.org/directives](http://www.iso.org/directives)

Attention is drawn to the possibility that some of the elements of this document may be the subject of patent rights. ISO shall not be held responsible for identifying any or all such patent rights. Details of any patent rights identified during the development of the document will be in the Introduction and/or on the ISO list of patent declarations received. [www.iso.org/patents](http://www.iso.org/patents)

Any trade name used in this document is information given for the convenience of users and does not constitute an endorsement.

The committee responsible for this document is ISO/TC 17, *Steel*, Subcommittee SC 20, *General technical delivery conditions, sampling and mechanical testing methods*.

This third edition cancels and replaces the second edition (ISO 377:1997), which has been technically revised and includes ISO 377:1997/Cor.1:1997.

# Steel and steel products — Location and preparation of samples and test pieces for mechanical testing

## 1 Scope

This International Standard specifies requirements for the identification, location and preparation of samples and test pieces intended for mechanical tests on steel sections, bars, rod, flat products and tubular products as defined in ISO 6929. If agreed in the order, this International Standard can also apply to other metallic products. These samples and test pieces are for use in tests that are carried out in conformity with the methods specified in the product or material standard or, in the absence of this, in the standard for the test method.

Where the requirements of the order or product standard differ from those given in this International Standard, then the requirements of the order or product standard apply.

## 2 Normative references

The following referenced documents are indispensable for the application of this document. For dated references, only the editions cited apply. For undated references, the latest edition of the referenced document, (including any amendments) apply.

ISO 3785, *Metallic materials — Designation of test specimen axes in relation to product texture*

ISO 6929, *Steel products — Vocabulary*

## 3 Terms and definitions

For the purposes of this document, the terms and definitions given in ISO 6929 and the following apply.

### 3.1

#### **test unit**

number of pieces or the tonnage of products to accept or reject together, on the basis of the verification tests carried out on sample products in accordance with the requirements of the product standard or order

Note 1 to entry: See [Figure 1](#).

### 3.2

#### **sample product**

item (e.g. bar, sheet, coil) selected for inspection or testing

Note 1 to entry: See [Figure 1](#).

### 3.3

#### **sample**

sufficient quantity of material taken from the sample product for the purpose of producing one or more test pieces

Note 1 to entry: See [Figure 1](#).

Note 2 to entry: In certain cases, the sample can be the sample product.

**3.4  
rough specimen**

part of a sample having undergone mechanical treatment, for the purpose of producing a test piece

Note 1 to entry: See [Figure 1](#).

**3.5  
test piece**

part of a sample or rough specimen, with specified dimensions, machined or unmachined, brought to a required condition for submission to a given verification test

Note 1 to entry: See [Figure 1](#).

Note 2 to entry: In certain cases, the test piece can be the sample or the rough specimen.

**3.6  
reference condition**

condition of a sample, rough specimen or test piece having undergone a heat treatment to represent the intended final condition of the product

Note 1 to entry: In such cases, the sample, rough specimen or test piece is called the reference sample, reference rough specimen or reference test piece.

## **4 General requirements**

### **4.1 Representative testing**

Sample, rough specimens and test pieces selected in accordance with [Annex A](#) shall be considered to be representative of the product.

NOTE As a result of their production sequence, e.g. melting, casting hot or cold forming or both, heat treatment etc., steel products are not homogeneous. The mechanical properties of samples taken from other locations can be different.

### **4.2 Identification of sample products, samples, rough specimens and test pieces**

Sample products, samples, rough specimens and test pieces shall be marked to ensure traceability to the original product and their location and orientation in that product. For this purpose, if, during the preparation of any one or more of the samples, rough specimens or test pieces, removal of the marks cannot be avoided, transfer of these marks shall be carried out before the existing marks are removed or in the case of automatic preparation equipment before the test piece is removed from the equipment. In the case of specific inspection and where requested by the purchaser, the transfer of the marks shall be carried out in the presence of the purchaser's representative.

In the case of fully automatic in line preparation and testing systems, marking of samples, rough specimens and test pieces is not necessary if an adequate control system exists, which defines the procedures to follow in the event of system failure.

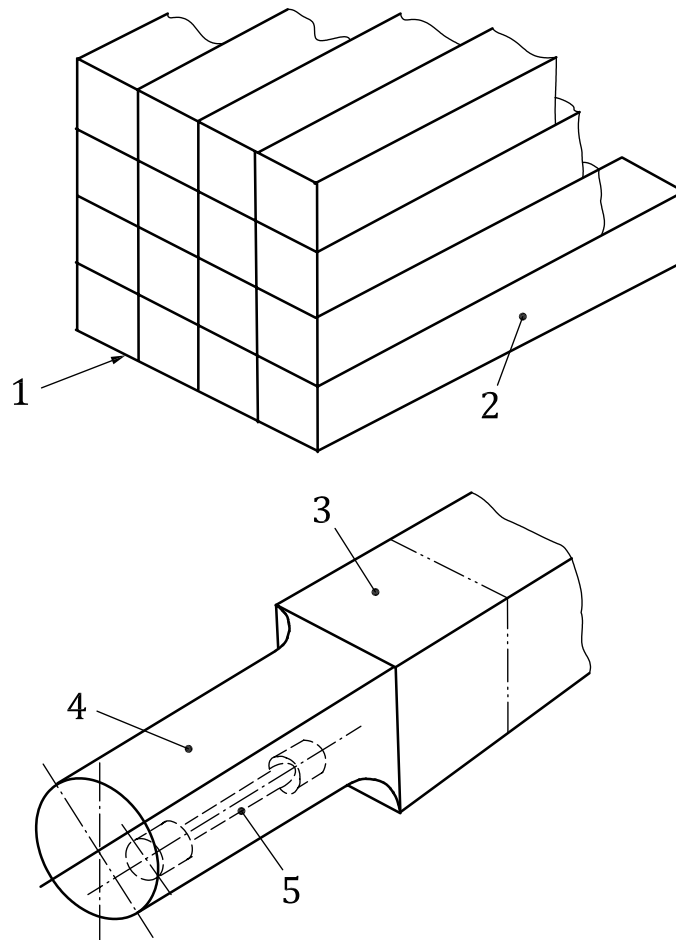

#### Key

- 1 test unit (3.1)
- 2 sample product (3.2)
- 3 sample (3.3)
- 4 rough specimen (3.4)
- 5 test piece (3.5)

Figure 1 — Examples of terms defined in [Clause 3](#)

## 5 Preparation of samples and selection of test pieces

### 5.1 Selection and dimensions of samples and location of test pieces

The sample shall be selected so that the test piece can be located as indicated in [Annex A](#). The sample shall have sufficient dimensions to allow sufficient test pieces required for carrying out specified tests, and for any retests that are necessary.

### 5.2 Direction of axis of test pieces

The direction of the test piece axis relative to the principle direction of working shall be as specified in the appropriate product standard or order. The designation of the test piece axis shall be in accordance with ISO 3785.

## 5.3 Condition and separation of samples

### 5.3.1 General

The material or product standard shall specify whether the test is intended to determine the properties

- a) in the as-delivered condition (see [5.3.2](#)); or
- b) in the reference condition (see [5.3.3](#)).

### 5.3.2 Testing in the as-delivered condition

A sample intended for testing in the as-delivered condition shall be separated from the product either

- a) after the forming or heat treatment processes or both have been completed; or
- b) before the heat treatment process, in which case the heat treatment of the separated sample shall be carried out under the same conditions as that of the product.

Separation of the sample shall be carried out in such a manner so as not to change the characteristics of that part of the sample used to provide the test pieces.

If flattening or straightening of the sample is unavoidable in the preparation of the test piece, the flattening or straightening shall be carried out cold unless otherwise specified in the product standard.

### 5.3.3 Testing in the reference condition

#### 5.3.3.1 Sample

A sample intended for testing in the reference condition shall be separated from the product at the stage of manufacture specified in the product standard or order.

Separation of the sample shall be carried out in such a manner so as not to change the characteristics of that part of the sample used to provide the test pieces after heat treatment.

Flattening or straightening, if necessary, can be carried out either hot or cold before any heat treatment. When carried out hot, it shall be at a temperature below the final heat treatment temperature.

#### 5.3.3.2 Rough specimen

A rough specimen intended for testing in the reference condition shall be prepared as follows.

- a) Mechanical treatment prior to heat treatment: when the sample is made smaller for the process of heat treatment, the product standard shall specify the dimensions to which the rough specimen shall be reduced and the reduction process e.g. forging, rolling, machining.
- b) Heat treatment: the heat treatment of the rough specimen shall take place in an environment where the uniformity of the temperature is adequately ensured and the temperature is measured by means of a calibrated instrument. The heat treatment shall be in accordance with the requirements of the product standard or of the order.

## 6 Preparation of test pieces

### 6.1 Cutting and machining

Cutting and machining of samples and rough specimens for the preparation of test pieces shall be carried out taking such precautions as necessary to avoid superficial work hardening and heating of the material likely to change the mechanical characteristics. After machining, any marks left by the tool that can interfere with the results of the test shall be removed, either by grinding (with ample coolant



supply) or by polishing, provided that the chosen method of finishing maintains the dimensions and shape of the test piece within the tolerances specified in the standard for the appropriate test.

The tolerances on the dimensions of the test pieces shall be those specified in the standards for the appropriate test methods.

## **6.2 Reference heat treatment**

When the required reference heat treatment is being carried out on the test piece, the provisions for heat treatment shall be the same as for the rough specimen [see [5.3.3.2 b](#)]).

## Annex A (normative)

### Location of samples and test pieces

#### A.1 General

This annex applies to the location of test pieces for the following product forms:

- sections;
- bars and rod;
- flat products;
- tubular products.

The location of test pieces for tensile and impact tests are indicated in [Figures A.1](#) to [A.15](#). For bend tests, the width position is as for the tensile test pieces.

When more than one test piece is required, they may be placed adjacent to each other in the location specified.

#### A.2 Sections

##### A.2.1 Location of test pieces across the width of section

The location of test pieces shall be in accordance with [Figure A.1](#).

For sections with tapered flanges; if agreed at the time of enquiry and ordering the sample may be taken from the web [see [Figure A.1 b](#)] and d)] or the sample from the tapered flange may be machined.

For products with non-tapered flanges greater than 150 mm, tensile samples shall be taken from the flange. For other products, if specified in national standards, the sample may be taken from the web.

For unequal leg angles, samples may be taken from either leg.

##### A.2.2 Location of test pieces in thickness of section

###### A.2.2.1 Tensile test pieces

The location of tensile test pieces shall be in accordance with [Figure A.2](#). The location of the test piece shall be under the outside surface of the flange unless otherwise specified in national standards. Full thickness test pieces [see [Figure A.2 a](#))] shall be used whenever machining and test equipment allows.

###### A.2.2.2 Impact test pieces

The location of impact test pieces shall be in accordance with [Figure A.3](#). The location of the test piece shall be under the outside surface of the flange unless otherwise specified in national standards.

### A.3 Round bars and rods

#### A.3.1 Tensile test pieces

The location of tensile test pieces shall be selected in accordance with [Figure A.4](#). Full section test pieces [see [Figure A.4 a](#)] shall be used whenever machining and test equipment allows.

#### A.3.2 Impact test pieces

The location of impact test pieces shall be selected in accordance with [Figure A.5](#).

### A.4 Hexagonal bars

#### A.4.1 Tensile test pieces

The location of tensile test pieces shall be selected in accordance with [Figure A.6](#).

Full section test pieces [see [Figure A.6 a](#)] shall be used whenever machining and test equipment allows.

#### A.4.2 Impact test pieces

The location of impact test pieces shall be selected in accordance with [Figure A.7](#).

### A.5 Rectangular bars

#### A.5.1 Tensile test pieces

The location of tensile test pieces shall be in accordance with [Figure A.8](#).

Full section or rectangular test pieces [see [Figures A.8 a](#)), b) or c)] shall be used whenever machining and test equipment allow.

#### A.5.2 Impact test pieces

The location of impact test pieces shall be in accordance with [Figure A.9](#).

### A.6 Flat products

#### A.6.1 Tensile test pieces

The location of tensile test pieces shall be in accordance with [Figure A.10](#).

Full section test pieces [see [Figure A.10 a](#)] shall be used whenever machining and test equipment allow. For quenched and tempered or thermomechanically rolled plates, the specimen thickness shall be either the full thickness or half the product thickness.

Where transverse tensile test pieces are specified and the width of flat product is not sufficient to take the test piece from the  $\frac{w}{4}$  location, then the centre of the test piece shall be as near to  $\frac{w}{4}$  as possible.

#### A.6.2 Impact test pieces

The location of impact test pieces shall be in accordance with [Figure A.11](#). Location d) is optional. For products of thickness  $\geq 40$  mm the location [[Figure A.11 a](#)), b) or c)] shall be specified in the product standard or in the order.

## A.7 Tubular products

### A.7.1 Tubes and circular hollow sections

#### A.7.1.1 Tensile test pieces

The location of tensile test pieces shall be selected in accordance with [Figure A.12](#). Full section test pieces [[Figure A.12 a](#)] shall be used whenever machining and test equipment allow.

For welded tubes, when testing the weld using strip test pieces, the weld shall be at the centre of the test piece.

NOTE 1 The full section test piece as shown in [Figure A.12 a](#)) is also applicable for a tube

- flattening test;
- drift expanding test;
- flanging test;
- ring expanding test;
- ring tensile test;
- bend test in full section.

NOTE 2 Test pieces shown in [Figure A.12 b](#)) are used for strip bend test.

If not specified in the product standard or in the order, the sampling position is at the discretion of the manufacturer.

#### A.7.1.2 Impact test pieces

The location of impact test pieces shall be in accordance with [Figure A.13](#). The locations apply to both seamless and welded tubes.

If not specified in the product standard or in the order, the sampling position is at the discretion of the manufacturer.

The orientation of test pieces is determined by the dimensions of the tube. Where a test piece is required in the transverse position the widest possible size between 10 mm and 5 mm shall be produced.

The minimum (nominal) diameter  $D_{\min}$  of the tube necessary to obtain such a test piece is given by Formula (A.1):

$$D_{\min} = (T - 5) + \frac{756,25}{T - 5} \quad (\text{A.1})$$

where  $T$  is the wall thickness.

Where the smallest permitted transverse test piece is not obtainable, the widest possible longitudinal size between 10 mm and 5 mm shall be used.

### A.7.2 Rectangular hollow sections

#### A.7.2.1 Tensile test pieces

The location of tensile test pieces shall be in accordance with [Figure A.14](#). Full section test pieces [see [Figure A.14 a](#)] shall be used whenever machining and test equipment allow.

**A.7.2.2 Impact test pieces**

The location of impact test pieces shall be in accordance with [Figure A.15](#).

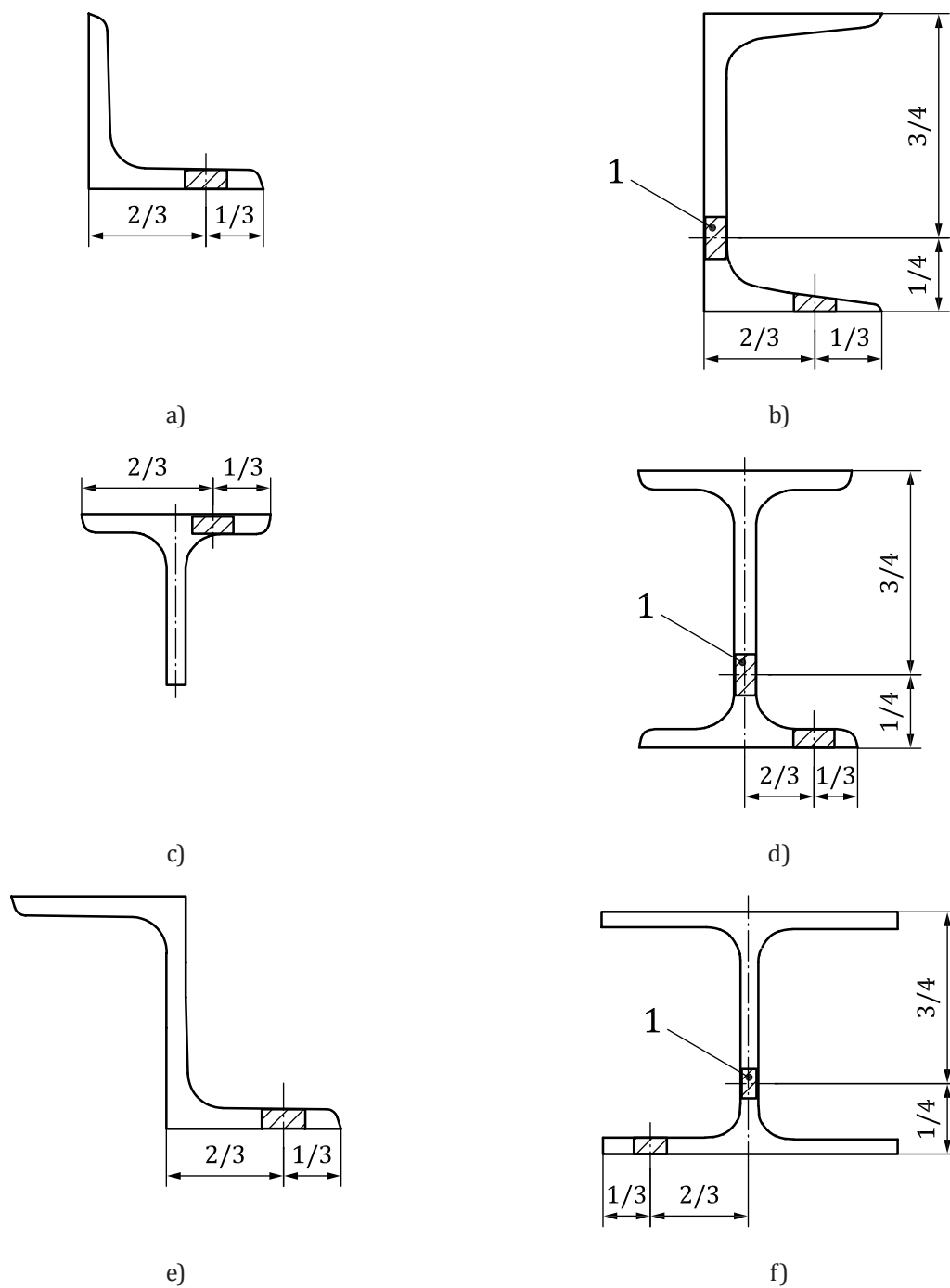

1 See [A.2.1](#).

**Figure A.1 — Sections — Location of test pieces for tensile and impact testing in width of flange (see [A.2.1](#))**

Dimensions in millimetres

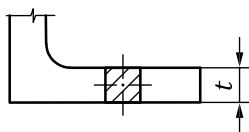

a) Full thickness test piece where  $t \leq 50$  mm

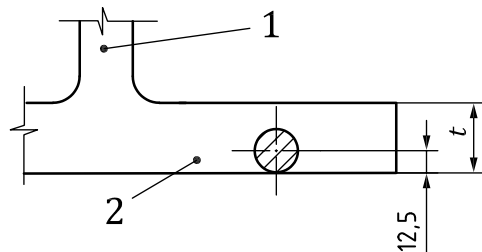

b) Round test piece where  $t \leq 50$  mm

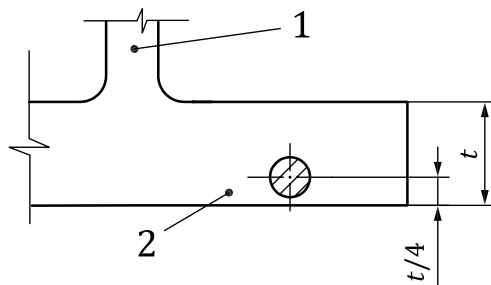

c) Round test piece where  $t > 50$  mm

**Key**

- 1 web
- 2 flange

**Figure A.2 — Sections — Location of test pieces for tensile testing in thickness of flange**  
(see [A.2.2.1](#))

Dimensions in millimetres

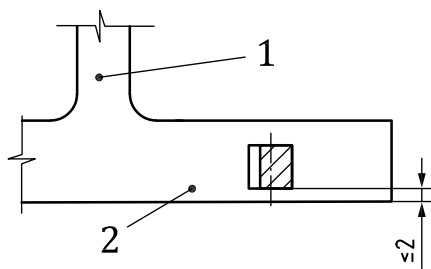

**Key**

- 1 web
- 2 flange

**Figure A.3 — Sections — Location of test pieces for impact testing in thickness of flange**  
(see [A.2.2.2](#))

Dimensions in millimetres

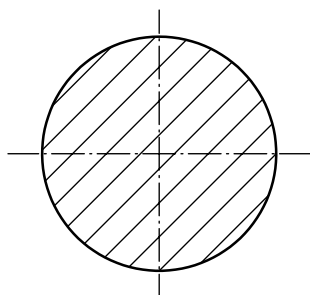

a) Full section test piece (preferred, see [A.3.1](#))

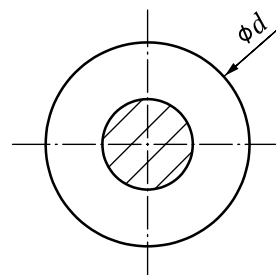

b) Round test piece where  $d \leq 25$  mm

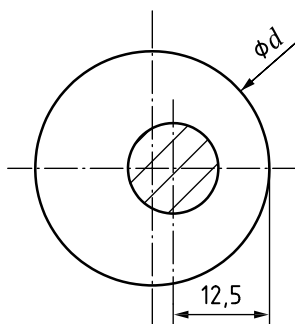

c) Round test piece where  $d > 25$  mm

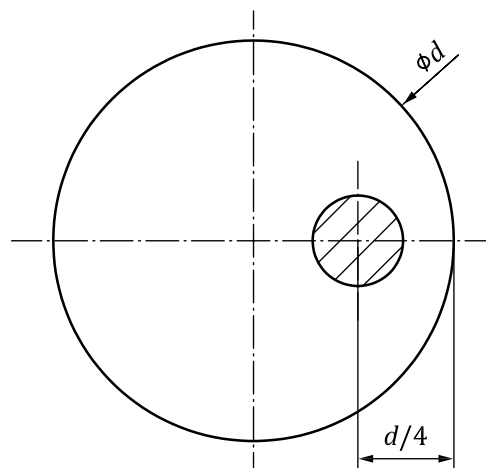

d) Round test piece where  $d > 50$  mm

**Figure A.4 — Round bar and rod — Location of test pieces for tensile testing**  
(see [A.3.1](#))

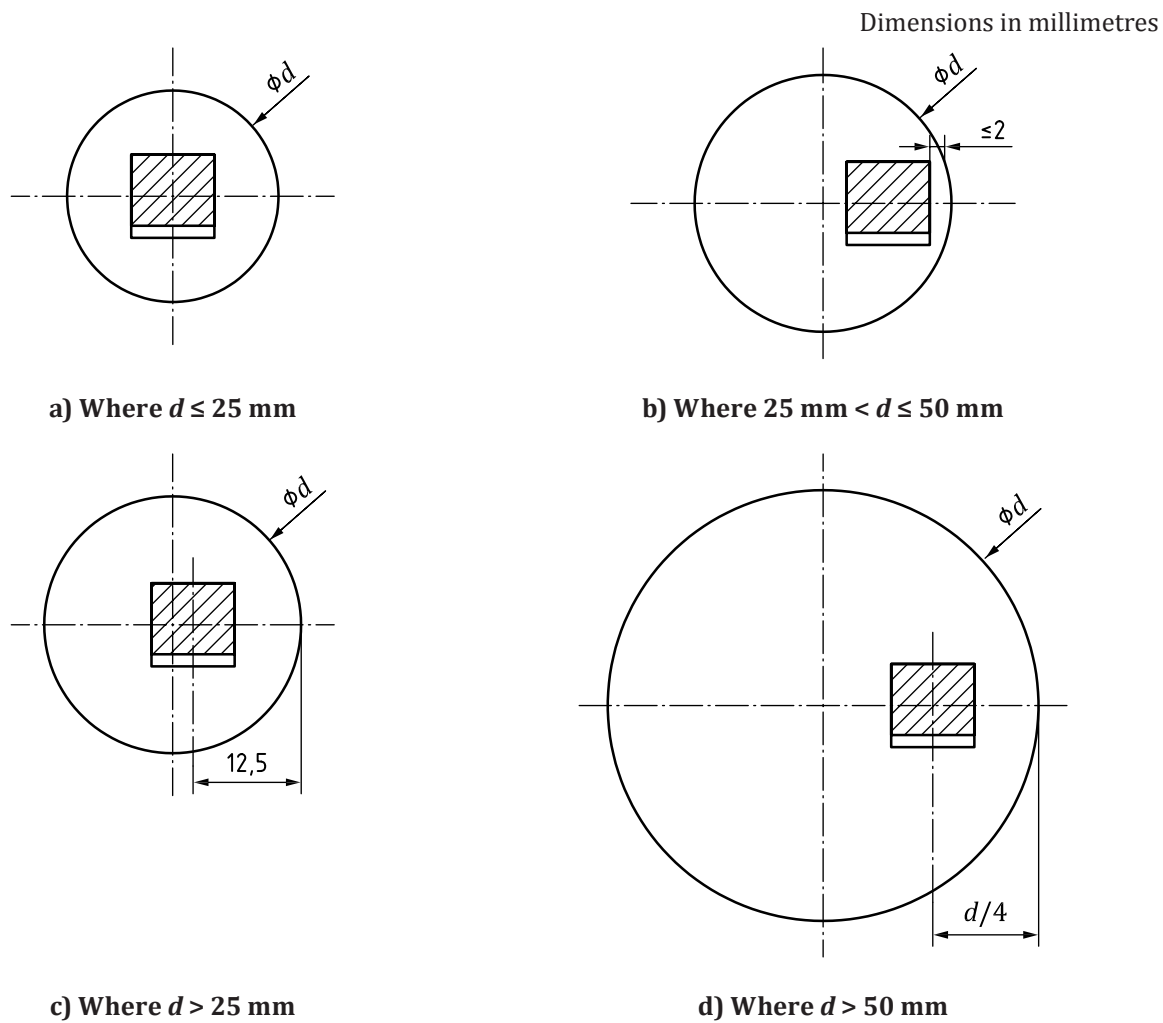
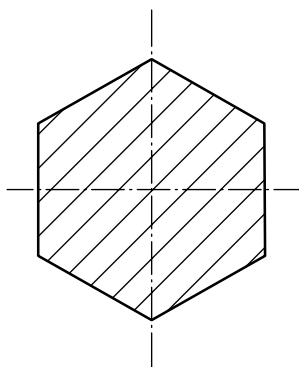

Figure A.5 — Round bar and rod — Location of test pieces for impact testing  
(see [A.3.2](#))



Dimensions in millimetres



a) Full section test piece (preferred, see [A.4.1](#))

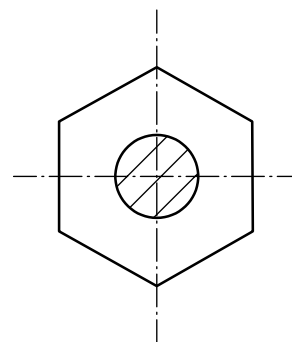

b) Round test piece where  $s \leq 25$  mm

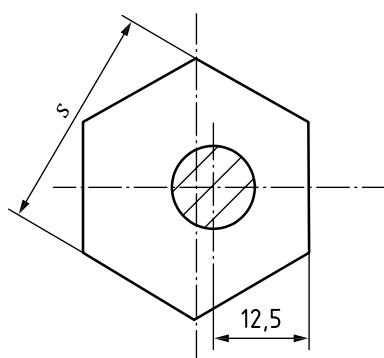

c) Round test piece where  $s > 25$  mm

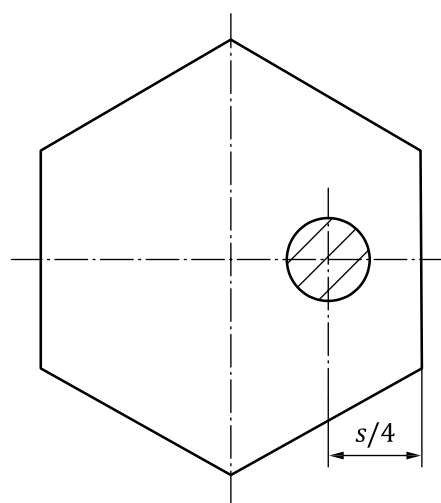

d) Round test piece where  $s > 50$  mm

**Figure A.6 — Hexagonal bar — Location of test pieces for tensile testing**  
(see [A.4.1](#))

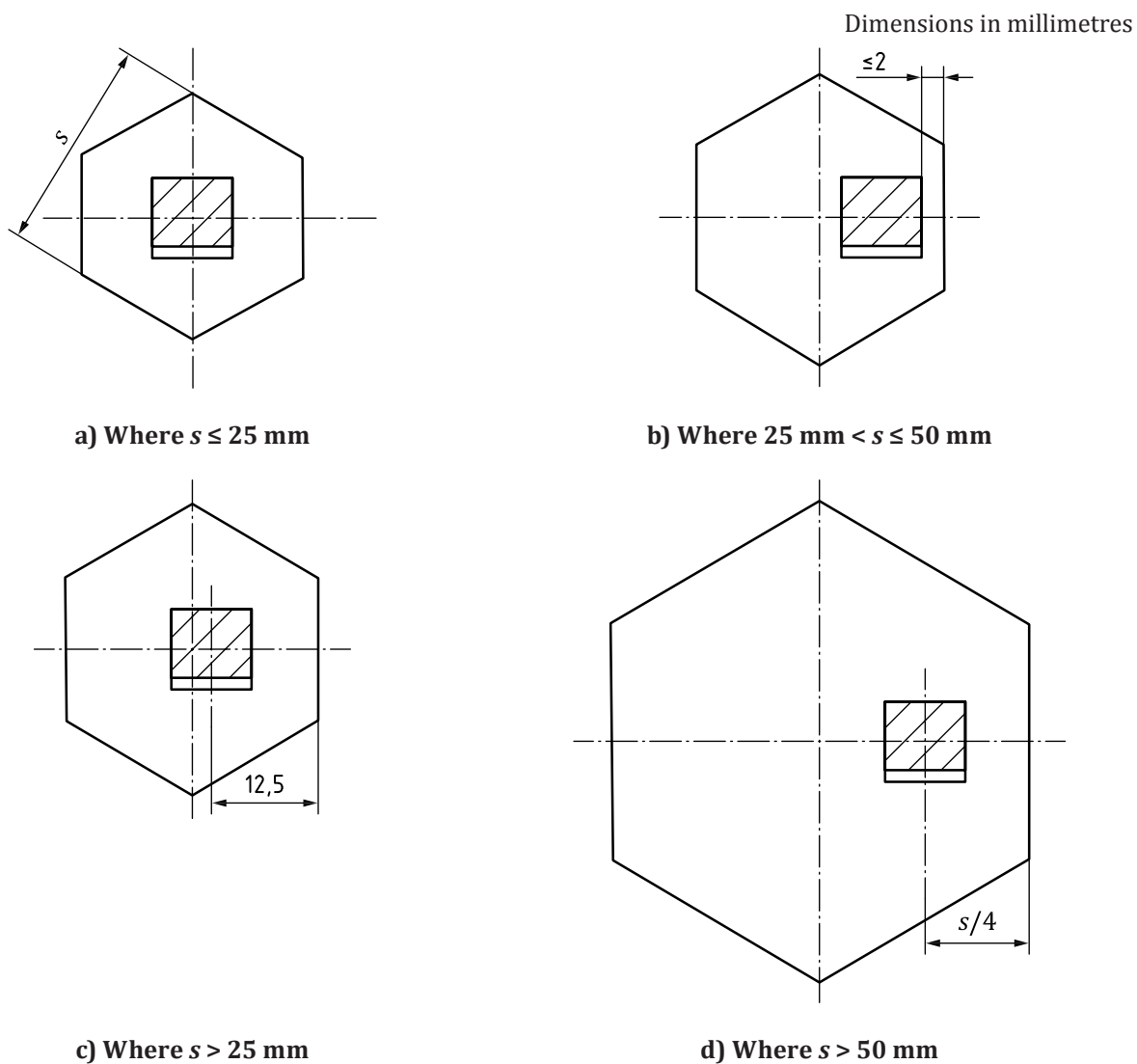
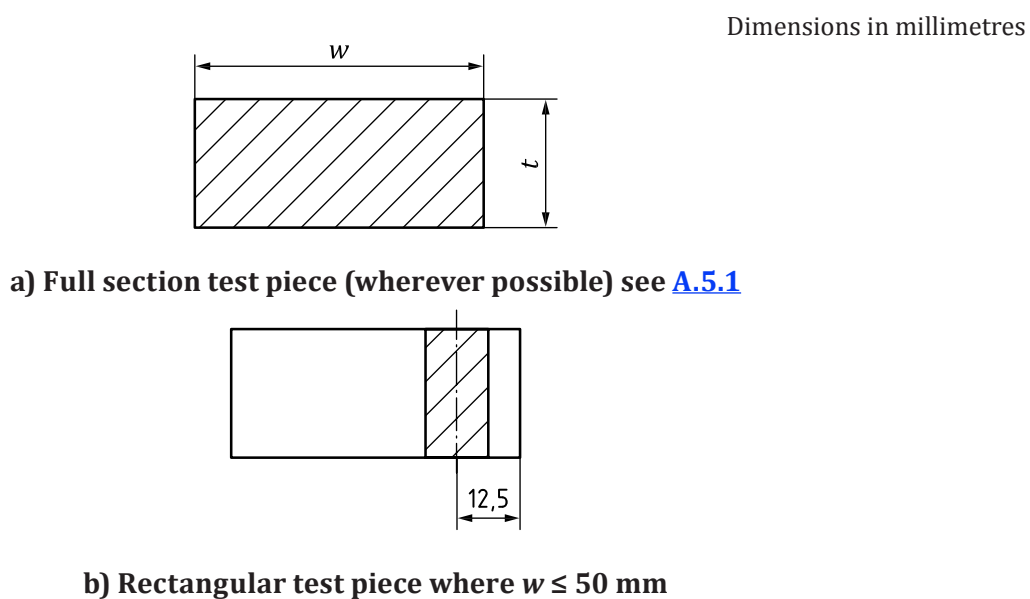
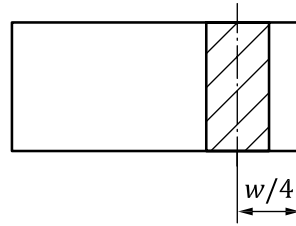
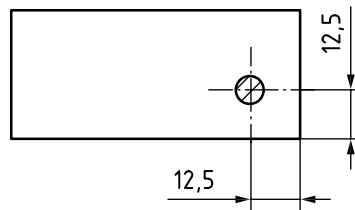

Figure A.7 — Hexagonal bar — Location of test pieces for impact testing  
(see [A.4.2](#))





c) Rectangular test piece where  $w > 50$  mm



d) Round test piece where  $w \leq 50$  mm and  $t \leq 50$  mm

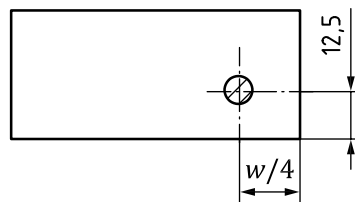

e) Round test piece where  $w > 50$  mm and  $t \leq 50$  mm

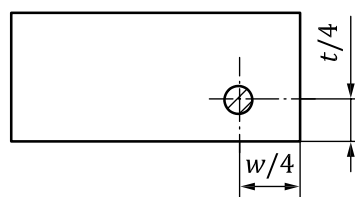

f) Round test piece where  $w > 50$  mm and  $t > 50$  mm

Figure A.8 — Rectangular bar — Location of test pieces for tensile testing  
(see [A.5.1](#))

Dimensions in millimetres

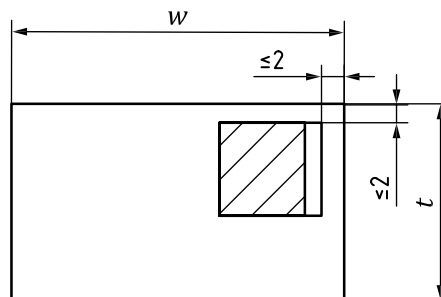

a) Where  $12 \text{ mm} \leq w \leq 50 \text{ mm}$  and  $t \leq 50 \text{ mm}$

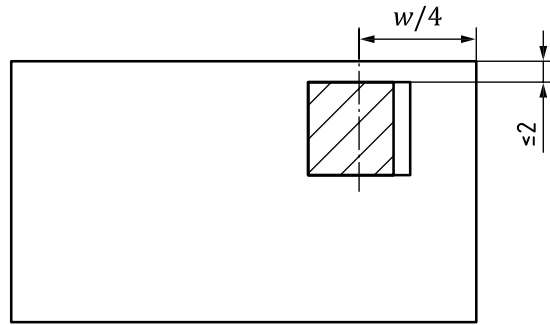

b) Where  $w > 50$  mm and  $t \leq 50$  mm

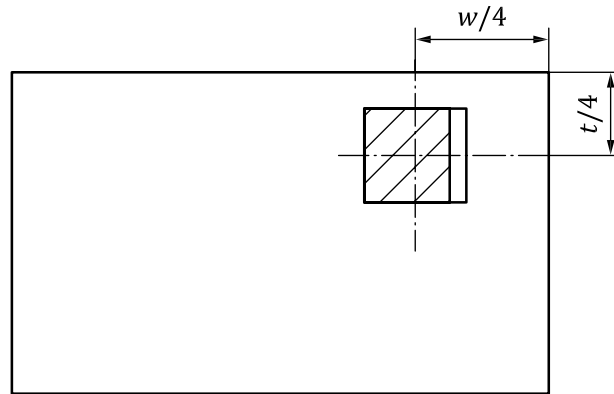

c) Where  $w > 50$  mm and  $t > 50$  mm

Figure A.9 — Rectangular bar — Location of test pieces for impact testing  
(see [A.5.2](#))

Dimensions in millimetres

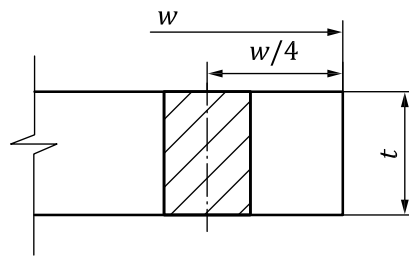
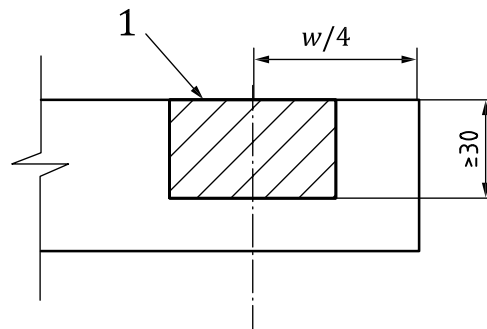
a) Full section test piece (preferred, see [A.6.1](#))

For quenched and tempered or thermomechanically rolled plates, the specimen [[Figure A.10 b](#)] shall be half the product thickness. In this case, the requirement for specimen thickness  $\geq 30$  mm does not apply.

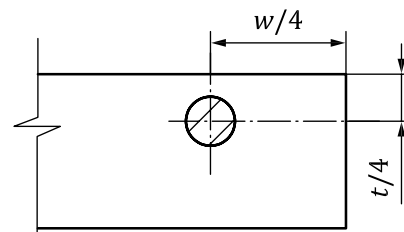
b) Rectangular test piece where  $t \geq 30$  mm

By agreement, the round test piece [[Figure A.10 c](#)] may be applied to flat products  $20 \text{ mm} \leq t < 25 \text{ mm}$ . In this case, the centre of the test piece shall be located at the centre of the thickness.

c) Round test piece where  $t \geq 25$  mm**Key**

1 rolled surface

**Figure A.10 — Flat products — Location of test pieces for tensile testing**  
(see [A.6.1](#))

Dimensions in millimetres

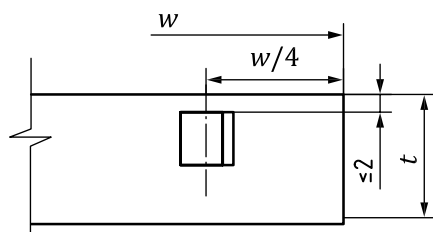

a) For all values of  $t$

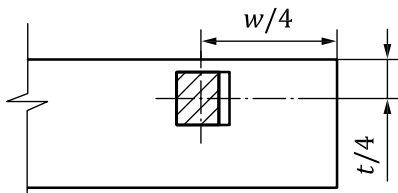

b) Where  $t \geq 40$  mm

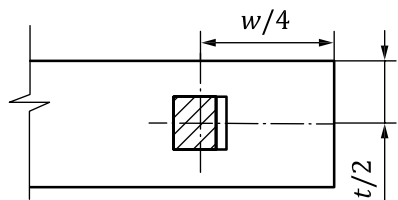

c) Where  $t \geq 40$  mm

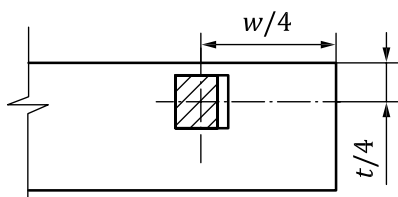

d) Where  $28 \text{ mm} \leq t < 40$  mm (optional)

Figure A.11 — Flat products — Location of test pieces for impact testing  
(see [A.6.2](#))

Dimensions in millimetres

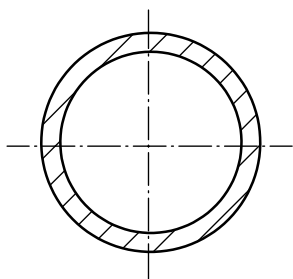

a) Full section test piece

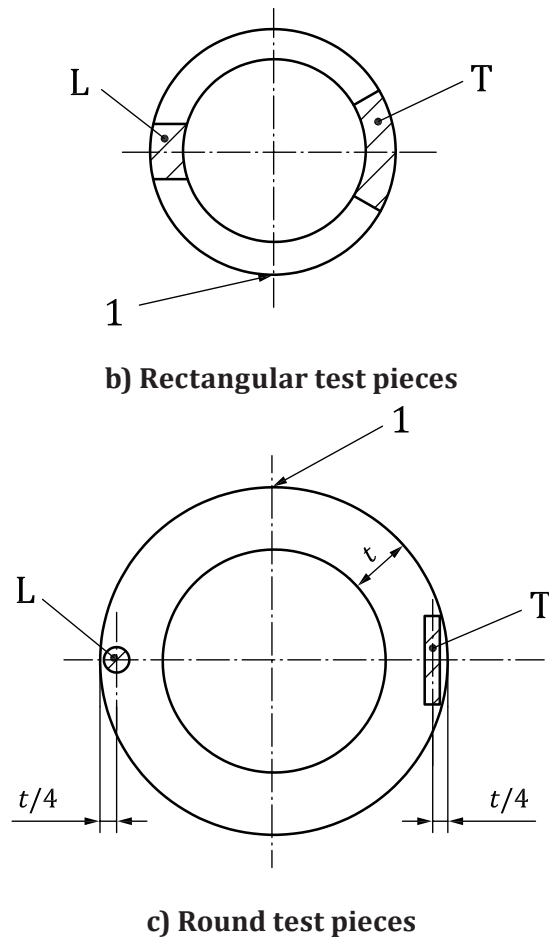
**Key**

- 1 weld joint for welded sections remote from test piece
- L longitudinal test piece
- T transverse test piece

**Figure A.12 — Tubular products — Location of test pieces for tensile testing of tubes and circular hollow sections**  
(see [A.7.1.1](#))

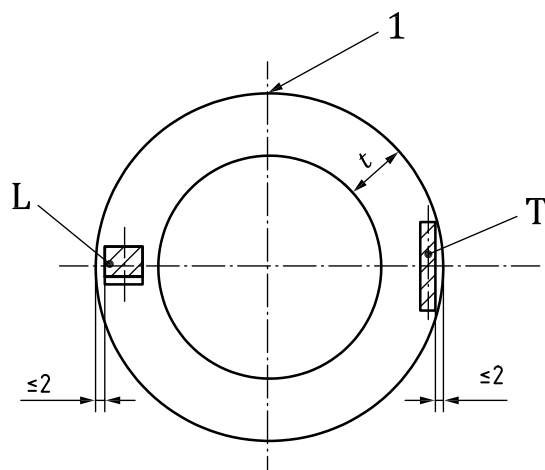

a) Impact test pieces

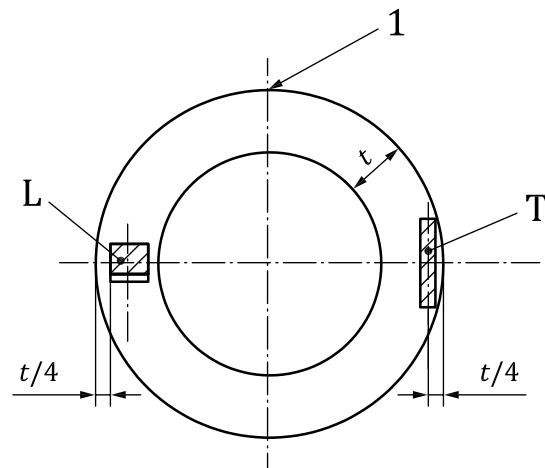

b) Impact test pieces where  $t > 40$  mm

**Key**

- 1 weld joint for welded sections remote from test piece
- L longitudinal test piece
- T transverse test piece

**Figure A.13 — Tubular products — Location of test pieces for impact testing of tubes and circular hollow sections**  
(see [A.7.1.2](#))



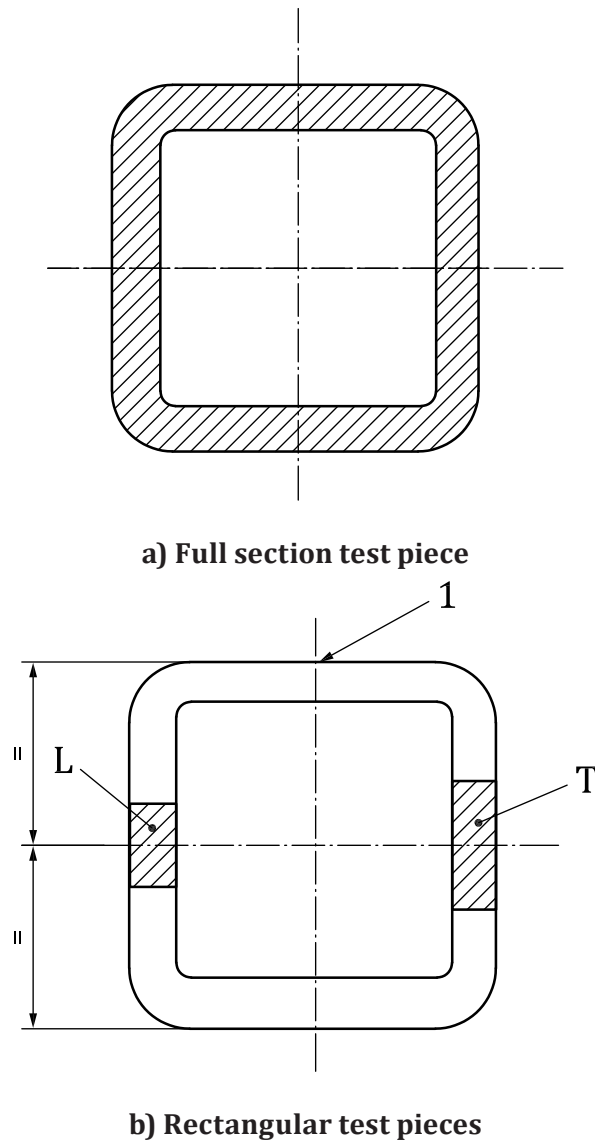

**Key**

- 1 weld joint for welded sections remote from test piece
- L longitudinal test piece
- T transverse test piece

**Figure A.14 — Tubular products — Location of test pieces for tensile testing of hollow sections**  
(see [A.7.2.1](#))

Dimensions in millimetres

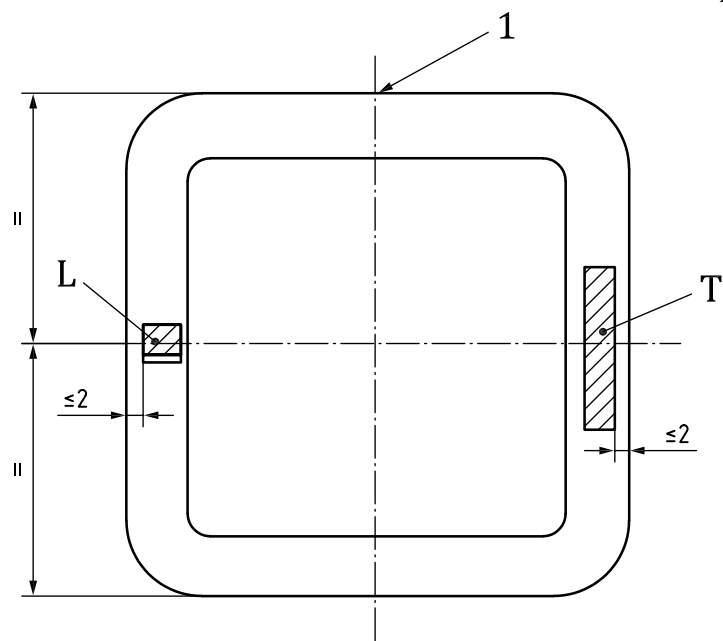

**Key**

- 1 weld joint for welded sections remote from test piece
- L longitudinal test piece
- T transverse test piece

**Figure A.15 — Tubular products — Location of test pieces for impact testing of hollow section**  
(see [A.7.2.2](#))



