

# INTERNATIONAL STANDARD

ISO  
366-1

First edition  
1988-02-01



---

INTERNATIONAL ORGANIZATION FOR STANDARDIZATION  
ORGANISATION INTERNATIONALE DE NORMALISATION  
МЕЖДУНАРОДНАЯ ОРГАНИЗАЦИЯ ПО СТАНДАРТИЗАЦИИ

---

## Textile machinery and accessories — Reeds —

### Part 1: Pitch bound reeds — Dimensions

*Matériel pour l'industrie textile — Peignes —*

*Partie 1: Peignes poissés — Dimensions*

Reference number  
ISO 366-1:1988 (E)

## Foreword

ISO (the International Organization for Standardization) is a worldwide federation of national standards bodies (ISO member bodies). The work of preparing International Standards is normally carried out through ISO technical committees. Each member body interested in a subject for which a technical committee has been established has the right to be represented on that committee. International organizations, governmental and non-governmental, in liaison with ISO, also take part in the work.

Draft International Standards adopted by the technical committees are circulated to the member bodies for approval before their acceptance as International Standards by the ISO Council. They are approved in accordance with ISO procedures requiring at least 75 % approval by the member bodies voting.

International Standard ISO 366-1 was prepared by Technical Committee ISO/TC 72, *Textile machinery and allied machinery and accessories*.

This first edition of ISO 366-1 cancels and replaces ISO 366 : 1982, of which it constitutes a minor revision.

Users should note that all International Standards undergo revision from time to time and that any reference made herein to any other International Standard implies its latest edition, unless otherwise stated.

© International Organization for Standardization, 1988 ●

Printed in Switzerland

# Textile machinery and accessories — Reeds —

## Part 1: Pitch bound reeds — Dimensions

### 0 Introduction

ISO 366 on reeds for use in the textile machinery industry comprises the following three parts:

Part 1: Pitch bound reeds — Dimensions. (This part of ISO 366.)

Part 2: Metal reeds with plate baulk — Dimensions.<sup>1)</sup>

Part 3: Metal reeds with double-spring baulk — Dimensions.<sup>2)</sup>

### 1 Scope and field of application

This part of ISO 366 specifies the dimensions of pitch bound reeds for use in the textile machinery industry.

1) At present at the stage of draft. (Revision of ISO 367 : 1976.)

2) At present at the stage of draft. (Revision of ISO 571 : 1976.)

ISO 366-1 : 1988 (E)

2 Dimensions

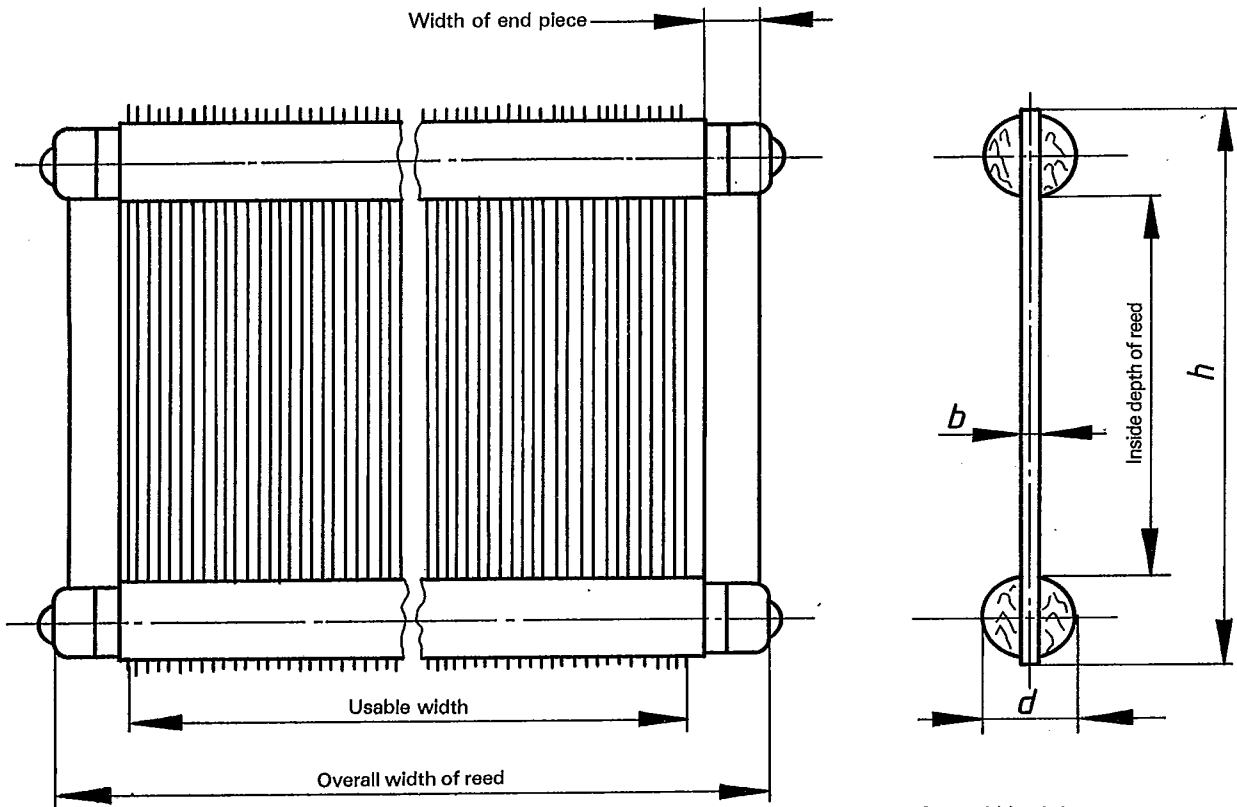

$b$  = width of dents  
 $d$  = thickness of reed baulk  
 $h$  = overall depth

Dimensions in millimetres

$h \backslash d$	$b$	(2,5)	3	4	5	6	8	10	12
	14	15	16	17	18	20	22	24	
110	x	x	x	x					
120	x	x	x	x					
130	x	x	x	x	x				
140	x	x	x	x	x	x			
150	x	x	x	x	x	x			
160			x	x	x	x	x		
180				x	x	x	x	x	
200				x	x	x	x	x	
220				x	x	x	x	x	
240				x	x	x	x	x	

NOTE — The value shown in parentheses should be avoided whenever possible.

UDC 677.054.845.2

Descriptors: weaving, textile machinery, reeds (textiles), dimensions.

Price based on 2 pages