

INTERNATIONAL STANDARD

ISO 303

Second edition
2002-09-01

Road vehicles — Installation of lighting and light signalling devices for motor vehicles and their trailers

*Véhicules routiers — Installation des feux d'éclairage et de signalisation
pour les véhicules à moteur et leurs remorques*



Reference number
ISO 303:2002(E)

© ISO 2002

PDF disclaimer

This PDF file may contain embedded typefaces. In accordance with Adobe's licensing policy, this file may be printed or viewed but shall not be edited unless the typefaces which are embedded are licensed to and installed on the computer performing the editing. In downloading this file, parties accept therein the responsibility of not infringing Adobe's licensing policy. The ISO Central Secretariat accepts no liability in this area.

Adobe is a trademark of Adobe Systems Incorporated.

Details of the software products used to create this PDF file can be found in the General Info relative to the file; the PDF-creation parameters were optimized for printing. Every care has been taken to ensure that the file is suitable for use by ISO member bodies. In the unlikely event that a problem relating to it is found, please inform the Central Secretariat at the address given below.

© ISO 2002

All rights reserved. Unless otherwise specified, no part of this publication may be reproduced or utilized in any form or by any means, electronic or mechanical, including photocopying and microfilm, without permission in writing from either ISO at the address below or ISO's member body in the country of the requester.

ISO copyright office
Case postale 56 • CH-1211 Geneva 20
Tel. + 41 22 749 01 11
Fax + 41 22 749 09 47
E-mail copyright@iso.ch
Web www.iso.ch

Printed in Switzerland

Contents

Page

Foreword	iv
1 Scope	1
2 Normative references	1
3 Terms and definitions	1
4 General specifications	5
4.1 Mounting of devices	5
4.2 Adjustment of setting	5
4.3 Angles of geometric visibility	5
4.4 Reference axis	5
4.5 Height and orientation check	5
4.6 Lamps constituting a pair	5
4.7 Vehicles with asymmetrical shape	5
4.8 Maximum and minimum heights	6
4.9 Width position	6
4.10 Flashing lamps	6
4.11 Avoiding light confusion	6
4.12 Assembly of lamps	6
4.13 Electrical connections	6
4.14 Lamp colours	6
4.15 Concealable lamps	7
4.16 Number of lamps	8
4.17 Lamps on movable components	8
4.18 Equivalent lamps	8
Annex A (normative) Lamp surfaces, reference axis and centre, and angles of geometric visibility	9
Annex B (normative) Illuminating and light-emitting surfaces	11
Annex C (normative) Visibility of red lamp to the front and of white lamp to the rear	13
Annex D (normative) Colorimetric characteristics of illuminating and signalling lights	15
Annex E (normative) Lighting devices — Specifications	17
Bibliography	67

Foreword

ISO (the International Organization for Standardization) is a worldwide federation of national standards bodies (ISO member bodies). The work of preparing International Standards is normally carried out through ISO technical committees. Each member body interested in a subject for which a technical committee has been established has the right to be represented on that committee. International organizations, governmental and non-governmental, in liaison with ISO, also take part in the work. ISO collaborates closely with the International Electrotechnical Commission (IEC) on all matters of electrotechnical standardization.

International Standards are drafted in accordance with the rules given in the ISO/IEC Directives, Part 3.

The main task of technical committees is to prepare International Standards. Draft International Standards adopted by the technical committees are circulated to the member bodies for voting. Publication as an International Standard requires approval by at least 75 % of the member bodies casting a vote.

Attention is drawn to the possibility that some of the elements of this International Standard may be the subject of patent rights. ISO shall not be held responsible for identifying any or all such patent rights.

ISO 303 was prepared by Technical Committee ISO/TC 22, *Road vehicles*, Subcommittee SC 8, *Lighting and signalling*.

This second edition cancels and replaces the first edition (ISO 303:1986), which has been technically revised.

Annexes A, B, C, D and E form a normative part of this International Standard.

Road vehicles — Installation of lighting and light signalling devices for motor vehicles and their trailers

1 Scope

This International Standard specifies the essential characteristics for the installation of lighting and light signalling devices on motor vehicles with or without bodywork and with at least four wheels, intended for on-road use and having a maximum design speed of more than 25 km/h, and their trailers. It is not applicable to vehicles that run on rails, to agricultural or forestry tractors and machinery, or to public works vehicles.

2 Normative references

The following normative documents contain provisions which, through reference in this text, constitute provisions of this International Standard. For dated references, subsequent amendments to, or revisions of, any of these publications do not apply. However, parties to agreements based on this International Standard are encouraged to investigate the possibility of applying the most recent editions of the normative documents indicated below. For undated references, the latest edition of the normative document referred to applies. Members of ISO and IEC maintain registers of currently valid International Standards.

ISO 612, *Road vehicles — Dimensions of motor vehicles and towed vehicles — Terms and definitions*

ISO 1176, *Road vehicles — Masses — Vocabulary and codes*

ISO 3833, *Road vehicles — Types — Terms and definitions*

ISO 4082, *Road vehicles — Motor vehicles — Flasher units*

ISO 4182, *Motor vehicles — Measurement of variations in dipped-beam headlamp angle as a function of load*

ISO 7227, *Road vehicles — Lighting and light signalling devices — Vocabulary*

ISO/TR 9819, *Road vehicles — Comparison tables of regulations on photometric requirements of light signalling devices*

ISO/TR 10603, *Road vehicles — Legal situation concerning lighting and light signalling devices*

3 Terms and definitions

For the purposes of this International Standard, terms and definitions given in ISO 612, ISO 3833, ISO 7227 and the following apply.

3.1

transverse plane

vertical plane perpendicular to the longitudinal median plane of the vehicle in accordance with ISO 612

3.2

ground

substantially horizontal surface on which the vehicle stands

3.3

unladen vehicle

vehicle without driver, crew, passengers and load, but with a full supply of fuel, spare wheel and normally carried tools

3.4

laden vehicle

vehicle loaded to its technically permissible maximum mass, as stated by the manufacturer, and with the distribution of this mass between the axles fixed by the manufacturer as specified in ISO 4182

3.5

extreme outer edge

plane on either side of the vehicle parallel to the longitudinal median plane of the vehicle (ISO 612) and touching its lateral outer edge, excepting the projection of

- tyres near their point of contact with the ground and connections for tyre-pressure gauges,
- any anti-skid devices mounted on the wheels,
- rear-view mirrors,
- side direction indicator lamps, end-outline marker lamps, front- and rear-position lamps, parking lamps, retro-reflectors and side-marker lamps, and
- customs seal affixed to the vehicle and devices for securing and protecting such seals

3.6

overall width

distance between the two vertical planes of the extreme outer edge

3.7

retro-reflecting device

retro-reflector

device used to indicate the presence of a vehicle or to identify a specific part of a vehicle by reflection of the light emanating from a light source not connected to the vehicle, the observer being near the source

[ISO 7227, definition 3.29]

NOTE For the purposes of this International Standard the following are not considered retro-reflectors: retro-reflecting number plates; the retro-reflecting signals mentioned in the European Agreement concerning the international carriage of dangerous goods on road (ADR); other retro-reflecting plates and signals that must be used to comply with national requirements for use as regards certain categories of vehicles or certain methods of operation.

3.8

illuminating surface

(lighting device) orthogonal projection of the full aperture of the reflector in a transverse plane

NOTE 1 If the lighting device has no reflector, the definition is the same as that given in 3.9 for the illuminating surface of a signalling device.

NOTE 2 If the lamp lens(es) extend(s) over part only of the full aperture of the reflector, then the projection of that part only is taken into account.

NOTE 3 In the case of a dipped-beam headlamp, having a screened light source giving a defined cut-off, the illuminating surface is limited by the apparent trace of the cut-off on to the lens. If the reflector and glass are adjustable relative to one another, the mean adjustment is used.

[ISO 7227, definition 3.35]

3.9**illuminating surface**

(signalling device) orthogonal projection of the lamp in a plane perpendicular to its reference axis and in contact with the exterior light-emitting surface of the lamp, this projection being bounded by the edges of screens situated in this plane, each allowing only 98 % of the total luminous intensity of the light to persist in the reference axis direction

[ISO 7227, definition 3.36]

3.10**reference axis**

axis of reference

characteristic axis of the light signal for use as the reference direction ($H = 0^\circ$, $V = 0^\circ$) for photometric measurements and when fitting the lamp on the vehicle

[ISO 7227, definition 3.40]

3.11**reference centre**

centre of reference

intersection of the reference axis with the light-emitting surface

[ISO 7227, definition 3.41]

3.12**angles of geometric visibility**

(lamp) angles which determine the widest solid angle in which the apparent surface of the lamp is visible

NOTE This solid angle is determined by the segments of a sphere in which the centre coincides with the reference centre of the lamp and the equator is parallel to the ground. These segments are determined in relation to the reference axis. The horizontal angles correspond to the longitude and the vertical angles to the latitude.

[ISO 7227, definition 3.42]

NOTE For the purposes of this International Standard, the horizontal angles are β_1 , corresponding to the outboard, and β_2 corresponding to the inboard, and the vertical angles are α_1 corresponding to "up" and α_2 corresponding to "down".

3.13**light-emitting surface**

all or surface part of the exterior surface of the transparent lens that encloses the lighting and light signalling devices and conforms to certain defined photometric and calorimetric conditions

[ISO 7227, definition 3.38]

3.14**apparent surface**

orthogonal projection of the light-emitting surface on a plane perpendicular to the observation direction and coinciding with the point on the lens closest to the observer

[ISO 7227, definition 3.39]

3.15**direction of observation**

direction from which the lamp is observed or tested, this testing being mainly conducted in the angles of geometric visibility or the angles of visibility of red light to the front and white light to the rear

3.16

single lamp

device or part of a device having one function and one illuminating surface, but possibly more than one light source

NOTE For installation on a vehicle, "single lamp" also means any assembly of two independent or grouped lamps, identical or not, having the same function, provided that the assembly complies with the specification for such a lamp. This possible combination does not apply to main beam headlamps, dipped-beam headlamps and front fog lamps.

[Adapted from ISO 7227, definition 3.7].

3.17

two lamps

even number of lamps

single apparent surface in the shape of a band or a strip, placed symmetrically in relation to the longitudinal median plane of the vehicle as defined in ISO 612, extending on both sides to within at least 0,4 m of the extreme outer edge, and being not less than 0,8 m long, the illumination of which is provided by not less than two light sources placed as close as possible to its ends

NOTE A single apparent surface may be constituted by a number of juxtaposed elements in the case where the projections of several individual apparent surfaces on a transverse plane occupy not less than 60 % of the area of the smallest rectangle circumscribing the projections of those individual apparent surfaces.

3.18

distance between two lamps

shortest distance between two apparent surfaces in the direction of the reference axis of two lamps facing in the same direction

NOTE Where the distance between the lamps clearly meets the requirements of this International Standard, the exact edges of apparent surfaces need not be determined.

3.19

movable component

body panel or other part of the vehicle, the position of which can be changed by tilting, rotating or sliding without the use of tools

NOTE The tiltable driver cab of a truck is not considered a movable component.

3.20

normal position

position of a movable component specified by the vehicle manufacturer for the normal condition of use and the park condition of the vehicle

3.21

normal condition of use

(motor vehicle) condition of being ready to move and with propulsion engine running, and with movable components in the normal position

3.22

normal condition of use

(trailer) condition of being connected to a drawing motor vehicle in the normal condition of use, with movable components in the normal position

3.23

park condition

(motor vehicle) condition of being at a standstill and propulsion engine not running, with movable components in the normal position

3.24

park condition

(trailer) condition of being connected to a drawing motor vehicle in the park condition, with movable components in the normal position

4 General specifications

4.1 Mounting of devices

The lighting and light signalling devices shall be so fitted that under the normal condition of use and notwithstanding the vibrations to which they may be subjected, they shall retain the characteristics specified by this International Standard and shall be in accordance with its requirements. In particular, it shall not be possible for the lamps to be inadvertently maladjusted.

4.2 Adjustment of setting

The main-beam, dipped-beam and front fog lamps shall be so installed that correct adjustment of their orientation can be easily carried out.

4.3 Angles of geometric visibility

There shall be no obstacle within the angles of geometric visibility that noticeably reduces the propagation of light from any part of the apparent surface of the lamp observed from infinity.

If viewed closer to the lamp, the direction of observation shall be moved in parallel to achieve the same result.

See annex A.

4.4 Reference axis

For all light signalling devices, including those mounted on the side panels, the reference axis of the lamp when fitted to the vehicle shall be parallel to the bearing plane of the vehicle on the road; in addition, it shall be perpendicular to the longitudinal median plane of the vehicle in the case of side retro-reflectors and of side-marker lamps, and parallel to that plane in the case of all other signalling devices. In each direction, a tolerance of $\pm 3^\circ$ may be allowed. Furthermore, any specific instructions as regards fitting laid down by the manufacturer shall be complied with.

See annex A.

4.5 Height and orientation check

In the absence of specific instructions, the height and orientation of lamps shall be verified with the vehicle unladen and placed on a flat, horizontal surface according to the normal condition of use.

4.6 Lamps constituting a pair

In the absence of specific instructions, lamps constituting a pair shall

- be fitted to the vehicle symmetrically in relation to the longitudinal median plane (this estimate to be based on the exterior geometrical form of the lamp and not on the edge of its illuminating surface, see annex B),
- be symmetrical to one another in relation to the longitudinal median plane (except with regard to the interior structure of the lamp),
- satisfy the same colorimetric requirements, and
- have substantially identical photometric characteristics.

4.7 Vehicles with asymmetrical shape

On vehicles whose external shape is asymmetrical, the requirements of 4.6 shall be satisfied so far as is possible.

4.8 Maximum and minimum heights

The maximum height above ground, H_1 , shall be measured from the highest point, and the minimum height above ground, H_2 , from the lowest point, of the apparent surface in the direction of the reference axis.

In the case of dipped-beam headlamps, H_2 shall be measured in relation to the ground from the lowest point of the effective outlet of the optical system (e.g. reflector, lens, projection lens), independent of its utilization.

Where H_1 and H_2 clearly meet the requirements of this International Standard, the exact edges of a surface need not be determined.

See annex E.

4.9 Width position

The position in respect of width shall be determined from the edge of the apparent surface in the direction of the reference axis, furthest from the longitudinal median plane of the vehicle when referred to the overall width, and from the inner edges of the apparent surface in the direction of the reference axis when referred to the distance between lamps.

Where the width position clearly meets the requirements of this International Standard, the exact edges of a surface need not be determined.

4.10 Flashing lamps

In the absence of specific instructions, no lamps other than direction indicator lamps and the vehicle hazard warning signals shall be flashing lamps, except that the side marker lamps may also flash at the same frequency (in phase or out of phase) with the front and rear direction indicators when a side direction indicator lamp is not installed.

4.11 Avoiding light confusion

To avoid confusion as to the direction in which a vehicle is facing, it is recommended that no red light be visible to the front (zone 1, see annex C), and no white light be visible to the rear (zone 2, see annex C), excepting white light to the rear from a reversing lamp and interior lighting.

4.12 Assembly of lamps

Lamps may be grouped, combined or reciprocally incorporated with one another provided that all requirements for each lamp regarding colour, position, orientation, geometric visibility, electrical connections and other requirements, if any, are fulfilled.

4.13 Electrical connections

The electrical connections shall be such that the front and rear position lamps, the end-outline marker lamps, if any, the side marker lamps, if any, and the rear registration plate lamp can only be switched on and off simultaneously. This condition does not apply when using front and rear position lamps, nor to side marker lamps when combined or reciprocally incorporated with the former, as parking lamps.

The electrical connections shall be such that the main-beam and dipped-beam headlamps and the front fog lamps cannot be switched on unless the lamps referred to in the preceding paragraph are also switched on. This requirement does not apply, however, to main-beam or dipped-beam headlamps when their luminous warnings consist of the intermittent lighting up at short intervals of the main-beam headlamp, the intermittent lighting up at short intervals of the dipped-beam headlamp, or the alternate lighting up at short intervals of the main-beam and dipped-beam headlamps.

4.14 Lamp colours

The colours of the light emitted by the lamps shall be in accordance with Table 1. For the colorimetric characteristics of lights, see annex D.

Table 1 — Lamp colours

Lamp	Colour
Dipped-beam headlamp	white
Main-beam headlamp	white
Front fog lamp	white or enlarged selective yellow
Front position lamp	white
Parking lamp	white in front, red at rear, amber if reciprocally incorporated in side direction indicator lamps or side-marker lamps.
Direction indicator lamp	amber
Stop lamp	red
Rear position lamp	red
Rear fog lamp	red
Reversing lamp	white
Rear registration plate lamp	white
Rear retro-reflector, triangular	red
Side retro-reflector (front and rear)	amber for front side retro-reflector, amber or red for rear side retro-reflector
Side marker lamp (front and rear)	amber for side front marker lamp, red or amber for rear side marker lamp
Side retro-reflector (intermediate)	amber
Side marker lamp (intermediate)	amber
End outline marker lamp	white in front, red at the rear
Front identification lamp	white
Rear identification lamp	red
Front retro-reflector, non triangular	identical to incident light
Rear retro-reflector, non triangular	red
Daytime running lamp	white
Hazard warning signal	amber
Cornering lamp	white

4.15 Concealable lamps

The concealment of lamps is prohibited excepting, and only when not in use, the

- main-beam headlamp,
- dipped-beam headlamp, and
- front fog lamp.

When all three of these lamps are concealed, the fitting of front retro-reflectors is recommended.

When concealable lamps are in use, they shall always be in their correct operating position, irrespective of any failure of the mechanism used for concealment.

4.16 Number of lamps

The number of lamps mounted on the vehicle shall be equal to the number specified for each lighting device in annex E.

4.17 Lamps on movable components

4.17.1 Lighting devices shall not be installed on glazing or on movable panels (e.g. deck lid, lift gate) unless such lighting devices are additional to primary lighting devices in compliance with the minimum requirements and mounted to fixed panels. Together, the combined primary and supplementary devices shall also meet all requirements. This includes

- position/park/tail/identification lamps,
- direction indicator lamps/hazard warning lamps (excluding side direction indicators), and
- reflex reflectors.

4.17.2 Headlamps may be mounted on movable panels, provided the headlamps in design position meet all requirements when active.

4.17.3 No movable component, with or without a lighting device installed, shall in any position hide more than 50 % of the apparent surface of a lighting device in accordance with 4.17.1 that provides the primary function when viewed in a direction parallel to the longitudinal axis of the vehicle.

4.18 Equivalent lamps

See ISO 7227.

Equivalent lamps may be installed providing they meet the requirements of this International Standard.

Annex A (normative)

Lamp surfaces, reference axis and centre, and angles of geometric visibility

The lamp surfaces, reference axis, reference centre and the angles of geometric visibility shall be in accordance with Figure A.1.

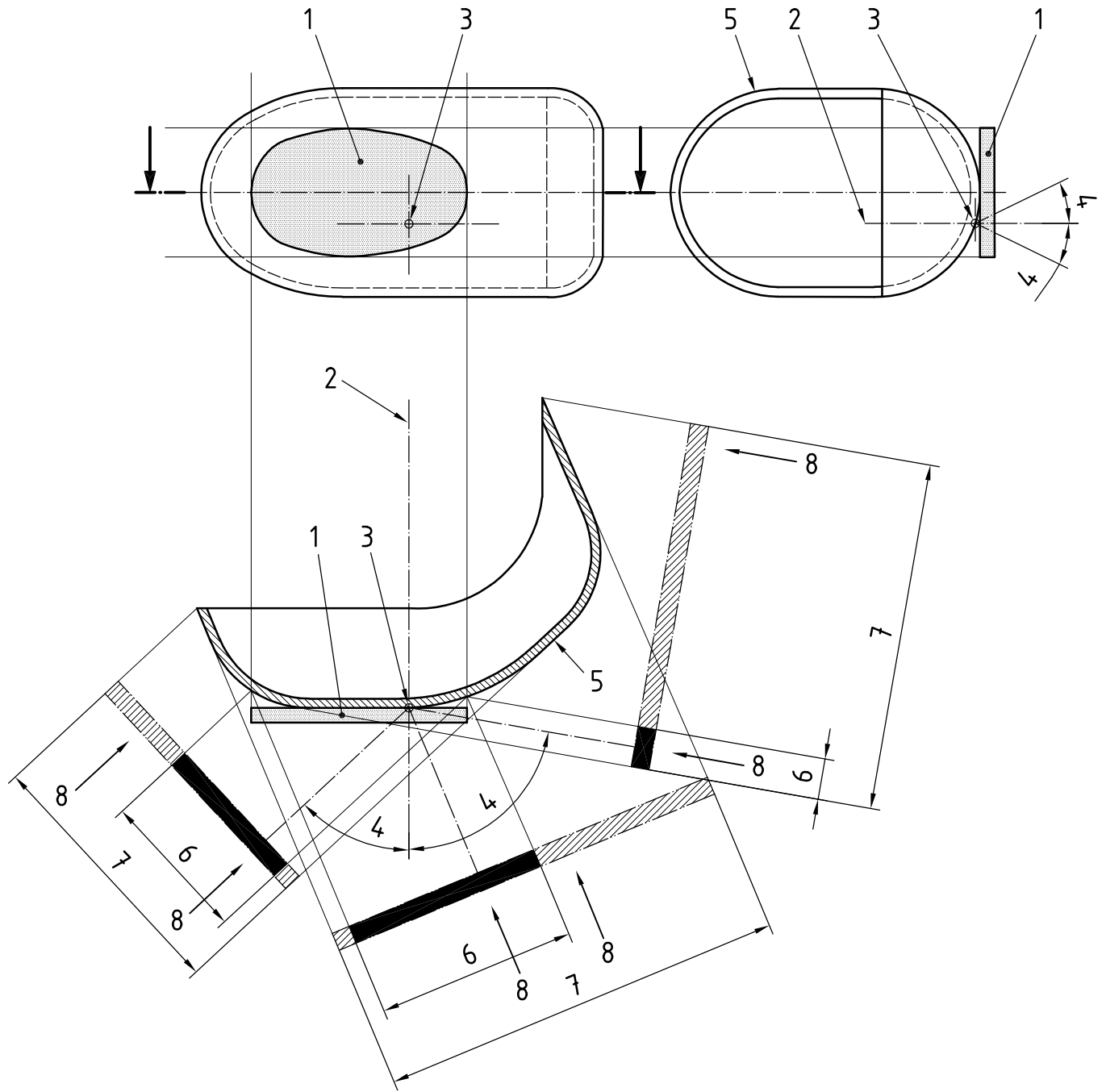

Notwithstanding the drawing, the apparent surface shall be considered as tangent to the light-emitting surface.

Key

- 1 Illuminating surface
- 2 Reference axis
- 3 Reference centre
- 4 Angle of geometric visibility
- 5 Light-emitting surface
- 6 Apparent surface based on illuminating surface
- 7 Apparent surface based on light-emitting surface
- 8 Direction of visibility

Figure A.1 — Lamp surfaces, reference axis and centre, and angle of geometric visibility

Annex B (normative)

Illuminating and light-emitting surfaces

The respective orthogonal projections of illuminating and light-emitting surfaces shall be in accordance with the examples shown in Figures B.1 and B.2.

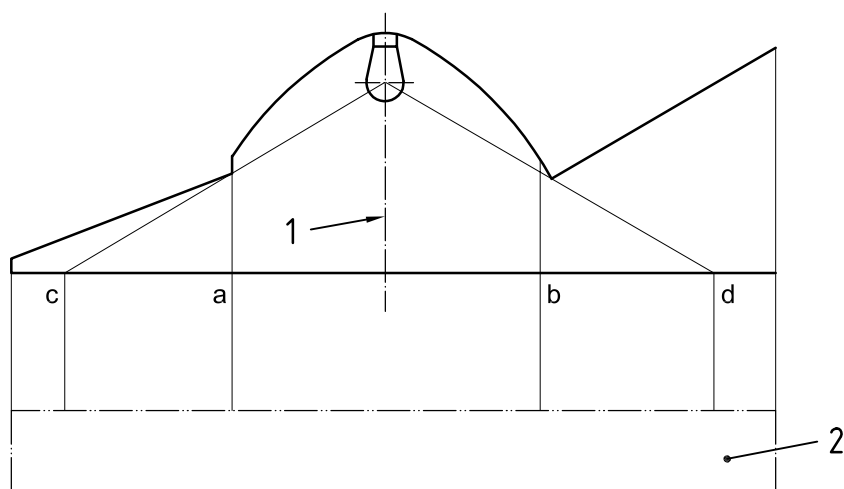

The orthogonal projection of the illuminating surface shall be as indicated by edges a and b.

The orthogonal projection of the light-emitting surface shall be as indicated by edges c and d.

Key

- 1 Axis of reference
- 2 Projection view

Figure B.1 — Apparent surface — Example 1

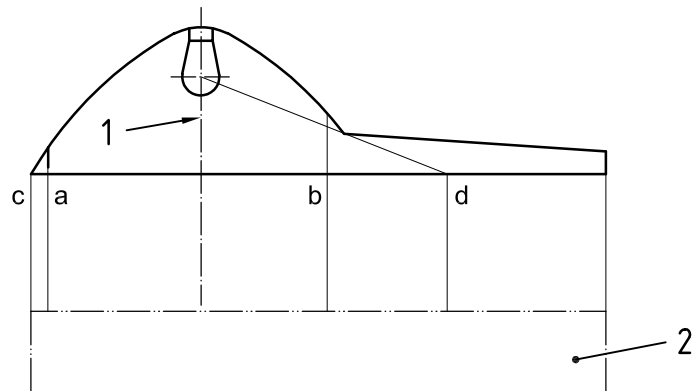

The orthogonal projection of the illuminating surface shall be as indicated by edges a and b.

The orthogonal projection of the light-emitting surface shall be indicated by edges c and d.

Key

- 1 Axis of reference
- 2 Projection view

Figure B.2 — Apparent surface — Example 2

Annex C (normative)

Visibility of red lamp to the front and of white lamp to the rear

The visibility required of a red lamp to the front of the vehicle and a white lamp to the rear shall be in accordance with Figures C.1 and C.2, respectively.

Dimensions in metres

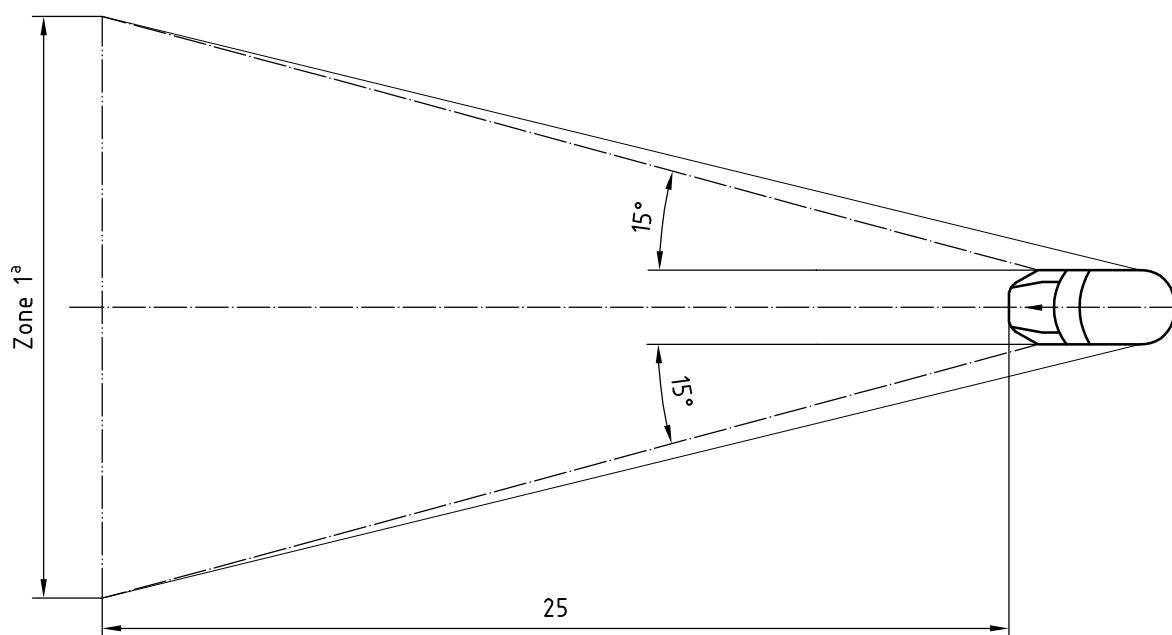

- ^a It is recommended that zone 1 extends in height above the ground from a minimum of 1 m to a maximum of 2,2 m.

Figure C.1 — Visibility of red lamp to front

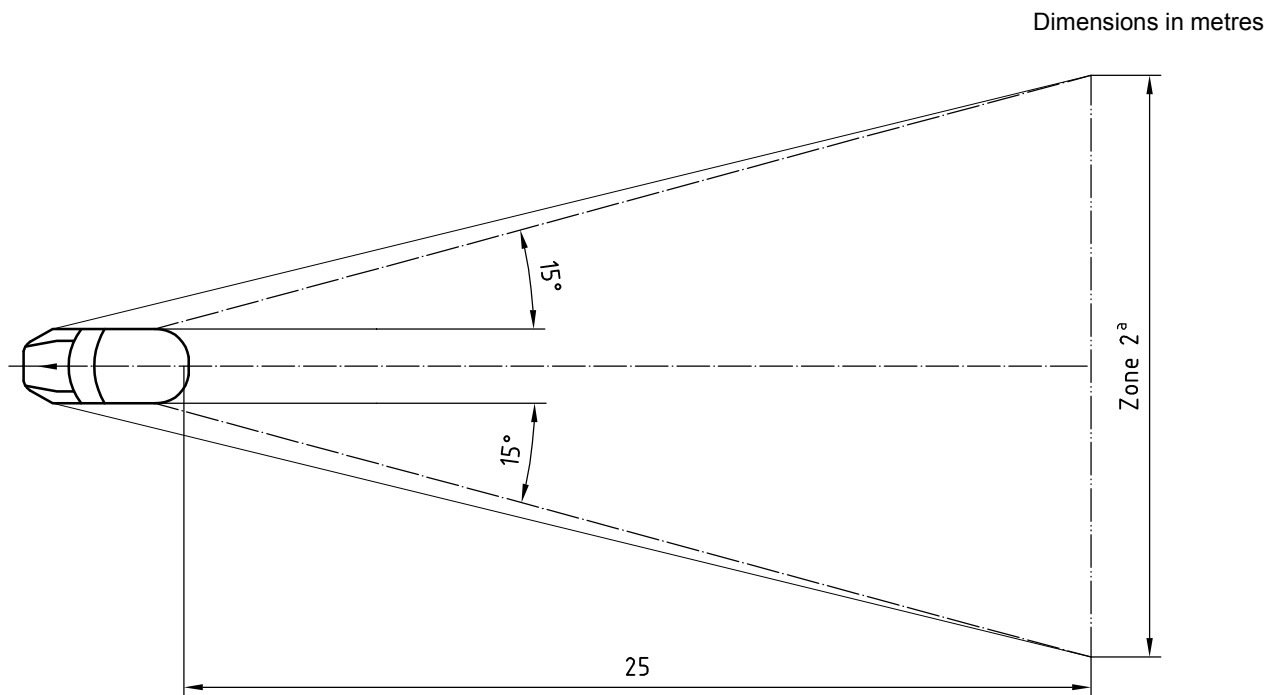

- ^a It is recommended that zone 2 extends in height above the ground from a minimum of 1 m to a maximum of 2,2 m.

Figure C.2 — Visibility of white lamp to rear

Annex D (normative)

Colorimetric characteristics of illuminating and signalling lights

D.1 Trichromatic coordinates

The trichromatic coordinates for illuminating and signalling lights shall be in accordance with Table D.1.

NOTE The trichromatic coordinates specified here do not necessarily conform with CIE S004 [1].

Table D.1 — Trichromatic coordinates

Red	Limit towards:	yellow	$y \leq 0,335$
		purple	$z \leq 0,008$
White	Limit towards:	blue	$x \geq 0,310$
		yellow	$x \leq 0,500$
		green	$y \leq 0,150 + 0,640x$
		green	$y \leq 0,440$
		purple	$y \geq 0,050 + 0,750x$
		red	$y \geq 0,382$
Amber	Limit towards:	green	$y \leq x - 0,120$
		red	$y \geq 0,390$
		white	$y = 0,790 - 0,670x$
Enlarged selective yellow	Limit towards:	red	$y \geq 0,138 + 0,580x$
		green	$y \leq 1,290x - 0,100$
		white	$y \geq -x + 0,940$
			$y \geq 0,440$
spectral value	$y \leq -x + 0,992$		

D.2 Colorimetric zones

Figure D.1 shows colorimetric zones corresponding to the recommended limits.

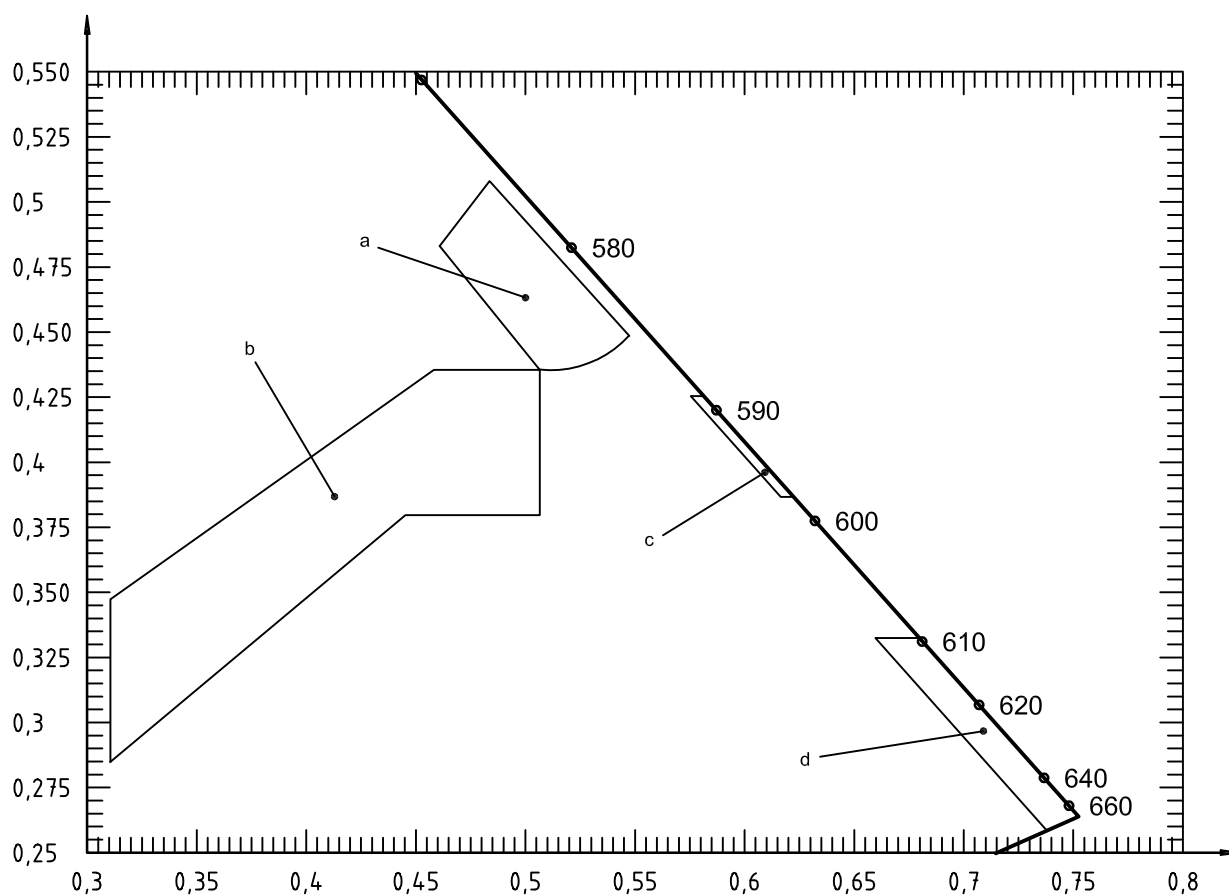

- a Enlarged selective yellow
- b White
- c Amber
- d Red

Figure D.1 — Colorimetric zones

Annex E (normative)

Lighting devices — Specifications

E.1 General

This annex gives the specifications for each type of lighting device that may be installed on the vehicle or trailer (see Table E.1 for index).

The layouts shown as figures are given as examples only, and are not restrictive.

Table E.1 — Specifications — Index

Lighting device	Clause
Dipped-beam headlamp	E.2
Main-beam headlamp	E.3
Front fog lamp	E.4
Front position lamp	E.5
Parking lamp	E.6
Front direction indicator lamp ^a	E.7
Side direction indicator lamp ^a	E.8
Rear direction indicator lamp ^a	E.9
Stop lamp	E.10
Stop lamp (centre high mounted)	E.11
Rear position lamp	E.12
Rear fog lamp	E.13
Reversing lamp	E.14
Rear registration plate lamp	E.15
Rear retro-reflector, non triangular	E.16
Side retro-reflector (front and rear)	E.17
Side marker lamp (front and rear)	E.18
Side retro-reflector (intermediate)	E.19
Side marker lamp (intermediate)	E.20
End outline marker lamp (front and rear)	E.21
Identification lamp (front and rear)	E.22
Front retro-reflector, non triangular	E.23
Rear retro-reflector, triangular	E.24
Daytime running lamp	E.25
Cornering lamp	E.26
^a Includes hazard warning signal.	

E.2 Dipped-beam headlamp

E.2.1 Layout

See Figure E.1.

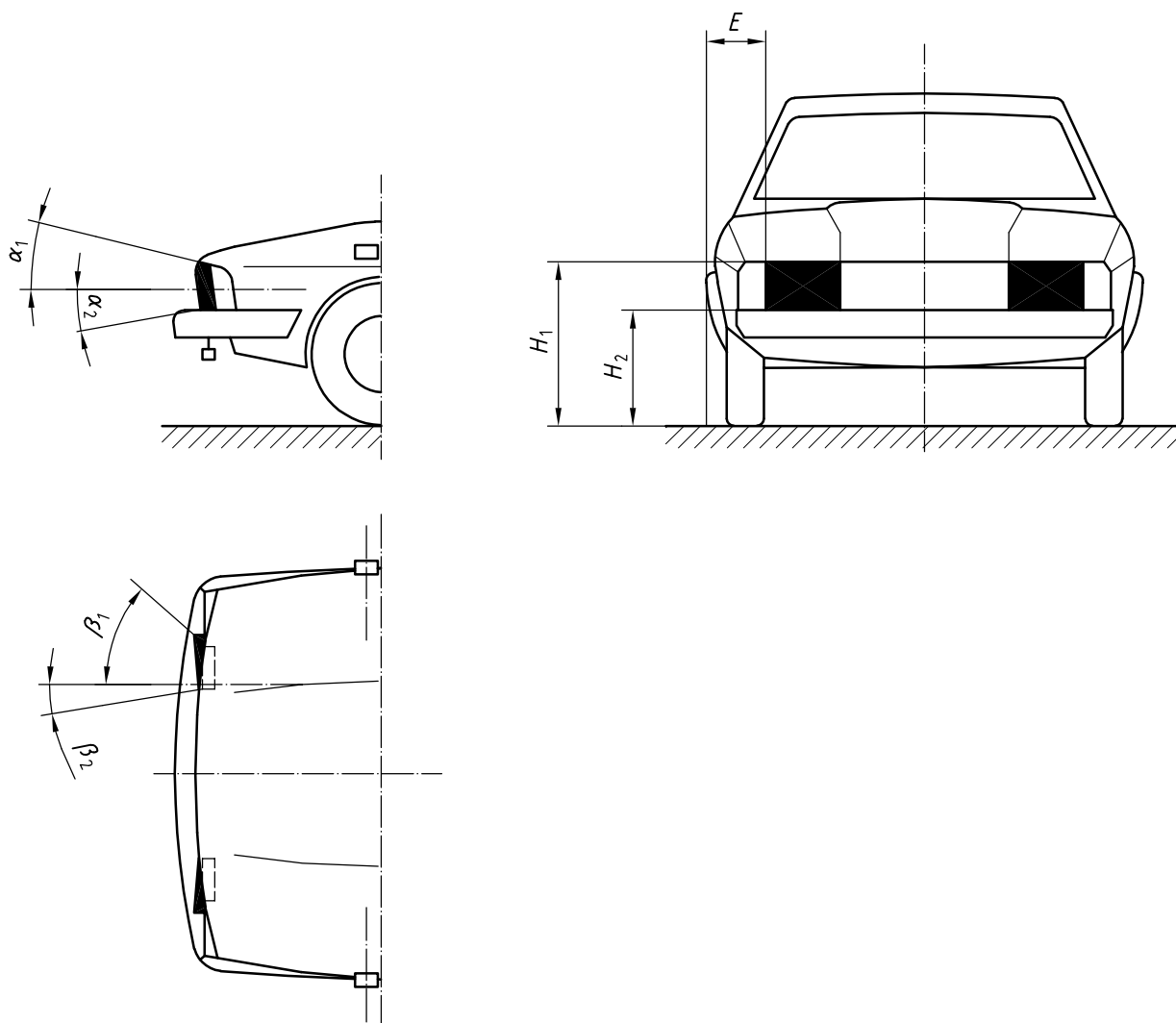

Figure E.1 — Dipped-beam headlamp

E.2.2 Application

For motor vehicles only.

E.2.3 Number

Two.

E.2.4 Dimensions (in millimetres)

$$H_1 \leq 1\,200$$

$$H_2 \geq 500$$

$$E \leq 400$$

E.2.5 Minimum angles of geometric visibility

$$\alpha_1: 15^\circ$$

$$\alpha_2: 10^\circ$$

$$\beta_1: 45^\circ$$

$$\beta_2: 10^\circ$$

E.2.6 Adjustment of dipped beam

The vertical inclination of the dipped beam shall be measured under static conditions and all loading conditions specified in ISO 4182. In the unladen vehicle state, with one person in the driving seat, the initial vertical downwards inclination shall be

a) for $h < 0,8$ m

— limits: between $-0,5$ % and $-2,5$ %

— initial aiming: between $-1,0$ % and $-1,5$ %

b) for $0,8 \leq h \leq 1,0$ m

— limits: between $-0,5$ % and $-2,5$ %

— initial aiming: between $-1,0$ % and $-1,5$ %

or, at the discretion of the manufacturer,

— limits: between $-1,0$ % and $-3,0$ %

— initial aiming: between $-1,5$ % and $-2,0$ %

c) for $h > 1,0$ m

— limits: between $-1,0$ % and $-3,0$ %

— initial aiming: between $-1,5$ % and $-2,0$ %

- d) for category N₃G (off-road) vehicles, where $h > 1,2$ m
 - limits for vertical inclination of cut-off: between $- 1,5$ % and $- 3,5$ %
 - initial aim: between $- 2,0$ % and $- 2,5$ %

The initial adjustment for each type of vehicle shall be expressly laid down by the manufacturer.

The vertical inclination shall remain between these limits under all loading conditions defined in ISO 4182.

E.2.7 Electrical connections

The control for changing over to the dipped-beam headlamps shall switch off all main-beam headlamps simultaneously.

The dipped beam may remain switched on at the same time as the main beam.

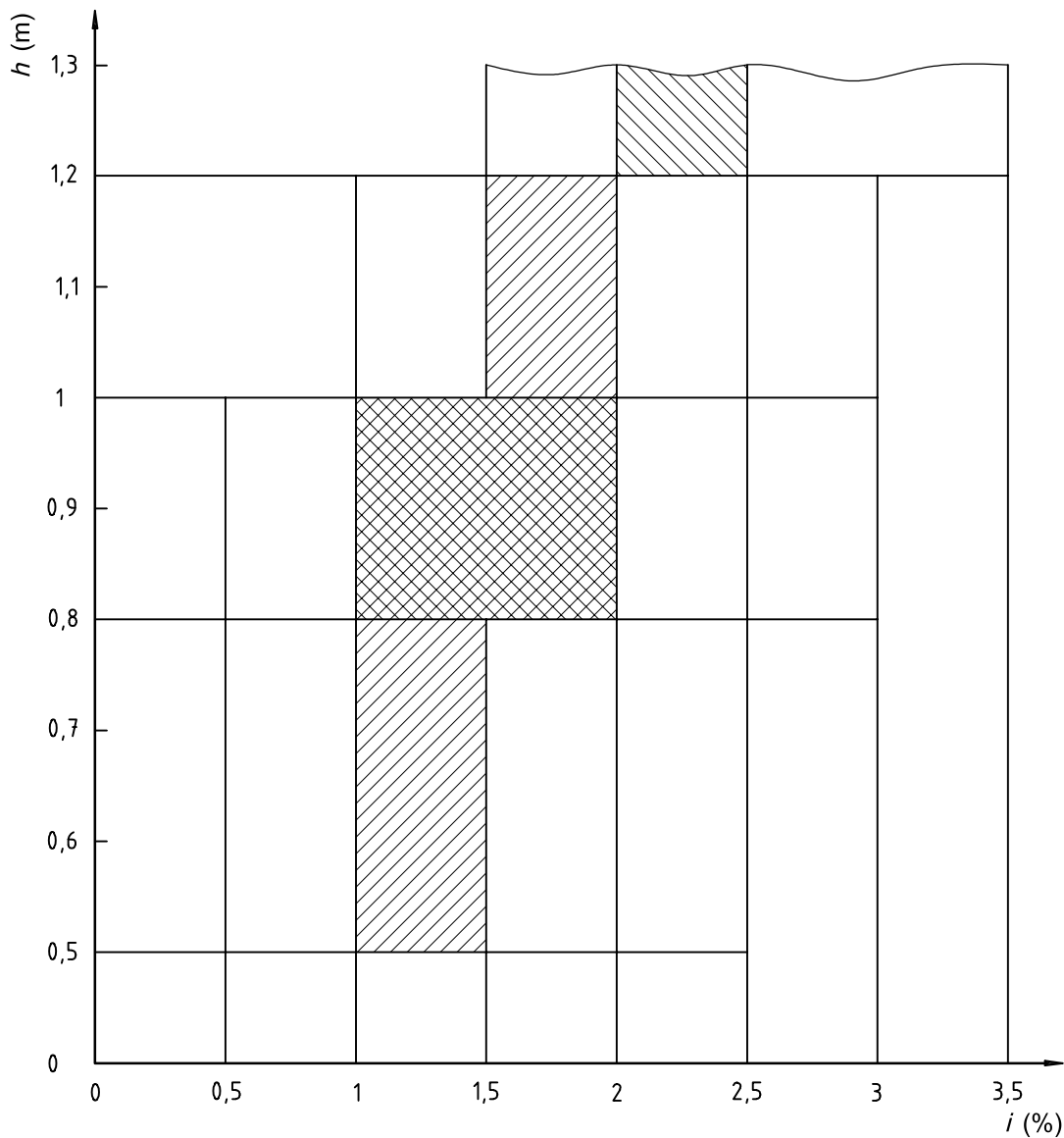

Figure E.2 — Dipped-beam vertical downwards inclination limit and initial aiming values

E.3 Main-beam headlamp

E.3.1 Layout

See Figure E.3.

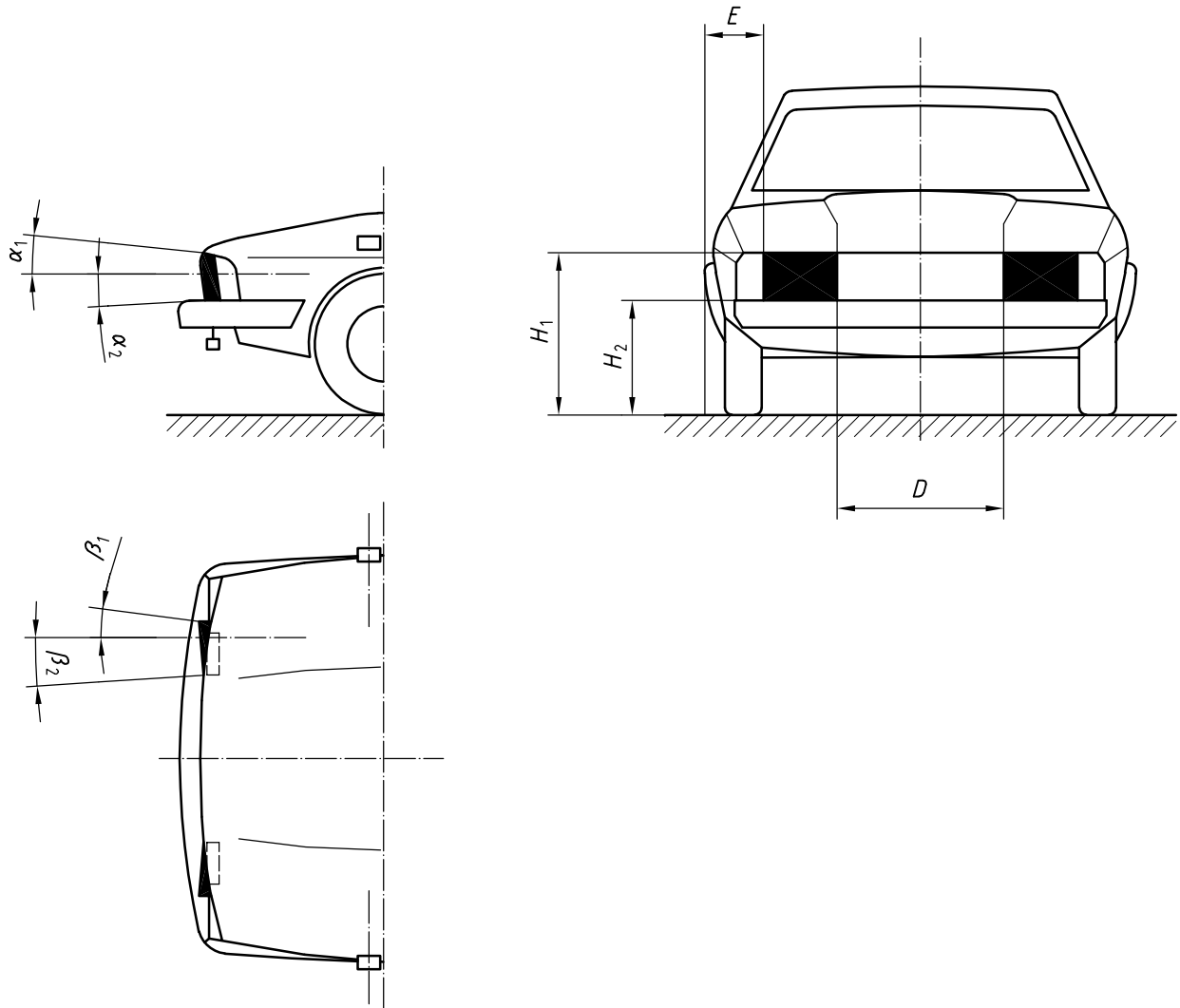

Figure E.3 — Main-beam headlamp

E.3.2 Application

For motor vehicles only.

E.3.3 Number

Two or four.

E.3.4 Dimensions (in millimetres)

H_1 : unspecified

H_2 : unspecified

E : unspecified

D : unspecified

E.3.5 Minimum angles of geometric visibility

The visibility of the illuminating surface, including its visibility in areas which do not appear to be illuminated in the direction of observation considered, shall be ensured within a divergent space defined by generating lines based on the perimeter of the illuminating surface and forming an angle of not less than 5° with the axis of reference of the headlamp. The origin of the angles of geometric visibility is the perimeter of the projection of the illuminating surface on a transverse plane tangent to the foremost part of the lens of the headlamp.

α_1 : 5°

α_2 : 5°

β_1 : 5°

β_2 : 5°

E.3.6 Electrical connections

The main-beam headlamps may be switched on either all simultaneously or in pairs.

For changing over from the dipped to the main beam, at least one pair of the main-beam headlamps shall be switched on.

For changing over from the main to the dipped beam, all main-beam headlamps shall be switched off simultaneously.

The dipped beam may remain switched on at the same time as the main beam.

E.4 Front fog lamp

E.4.1 Layout

See Figure E.4.

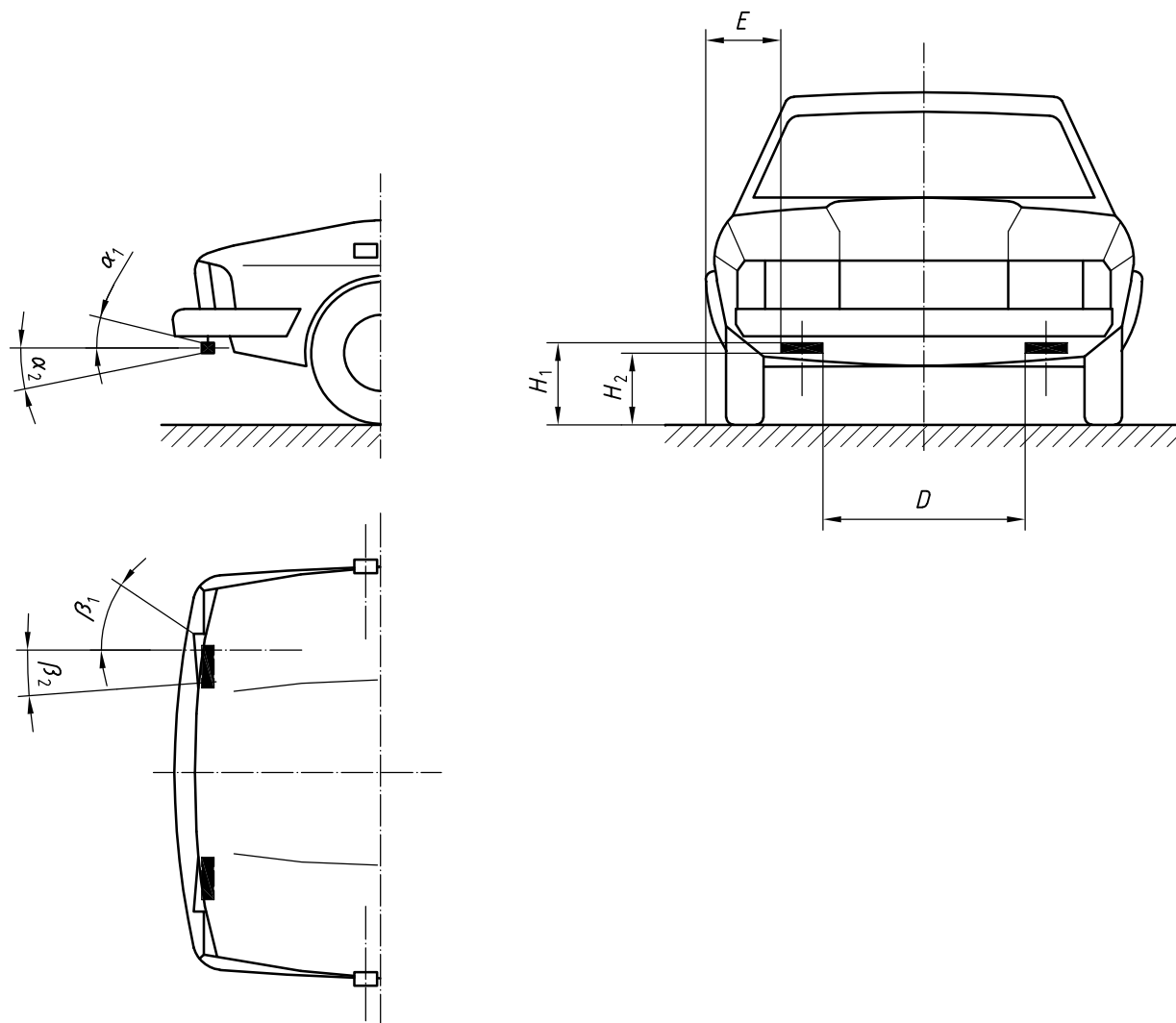

Figure E.4 — Front fog lamp

E.4.2 Application

For motor vehicles only.

E.4.3 Number

Two.

E.4.4 Dimensions (in millimetres)

$H_1 \leq 800$ (the front fog lamp shall not be higher than the dipped-beam headlamp)

$H_2 \geq 250$

D : unspecified

$E \leq 400$

E.4.5 Minimum angles of geometric visibility

$$\alpha_1: 5^\circ$$

$$\alpha_2: 5^\circ$$

$$\beta_1: 45^\circ$$

$$\beta_2: 10^\circ$$

E.4.6 Electrical connections

The front fog lamp shall be operated by means of an independent switch.

E.5 Front position lamp

E.5.1 Layout

See Figure E.5.

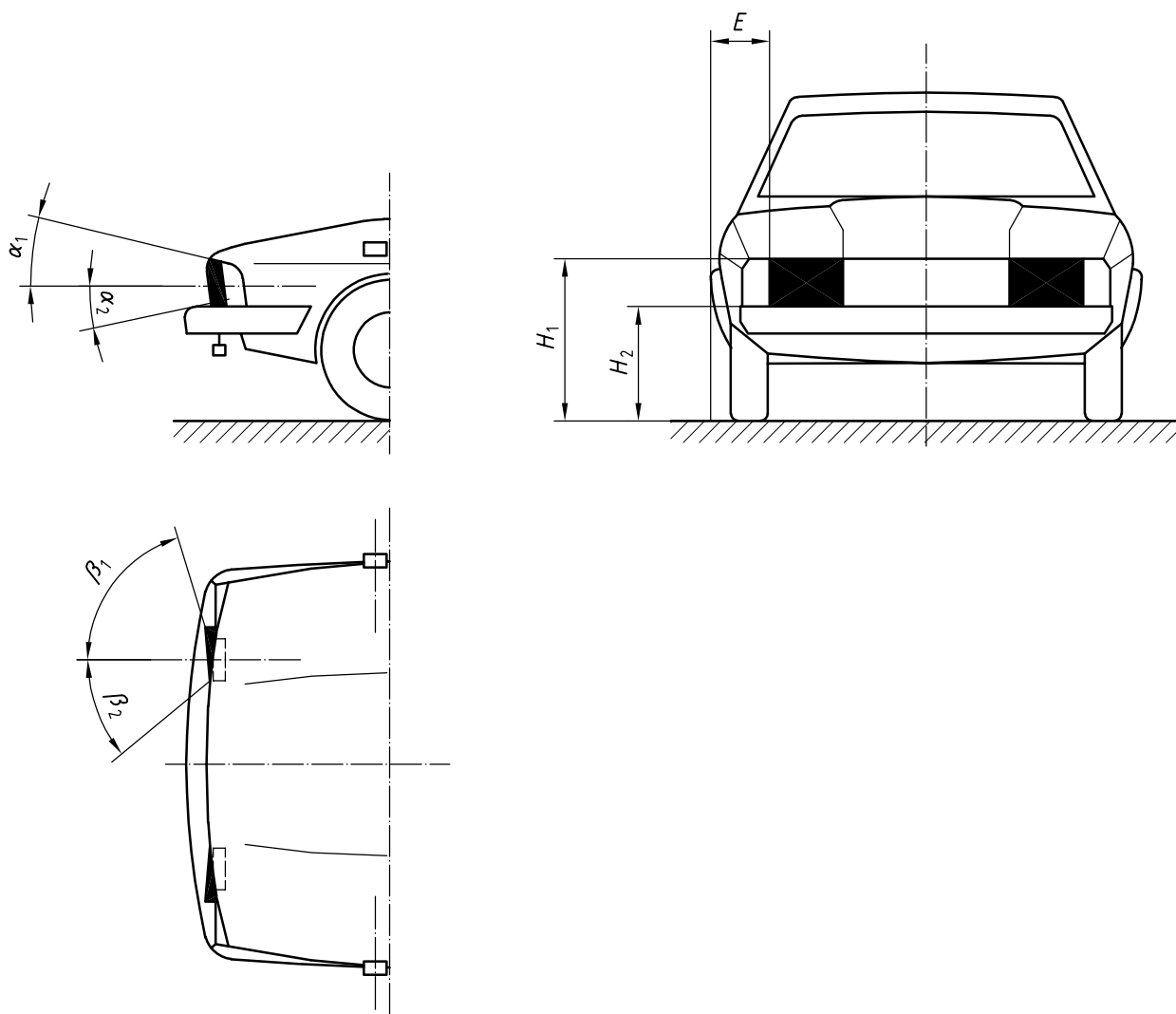

Figure E.5 — Front position lamp

E.5.2 Application

For motor vehicles and trailers.

E.5.3 Number

Two or four (except for single lamp).

E.5.4 Dimensions (in millimetres)

$H_1 \leq 1\,500$ (or $2\,100$ if the shape of the bodywork prevents compliance with $1\,500$)¹⁾

$H_2 \geq 350$

$E \leq 400$ for motor vehicles

$E \leq 150$ for trailers

E.5.5 Minimum angles of geometric visibility

α_1 : 15°

α_2 : 15° (5° if $H_2 < 750$ mm)

β_1 : 80° (or 45° if side marker lamps are installed on the vehicle)

β_2 : 45°

E.5.6 Electrical connections

See 4.13.

1) If there are two pairs of lamps, the value applies only to one of the two pairs.

E.6 Parking lamp

E.6.1 Layout

See Figure E.6.

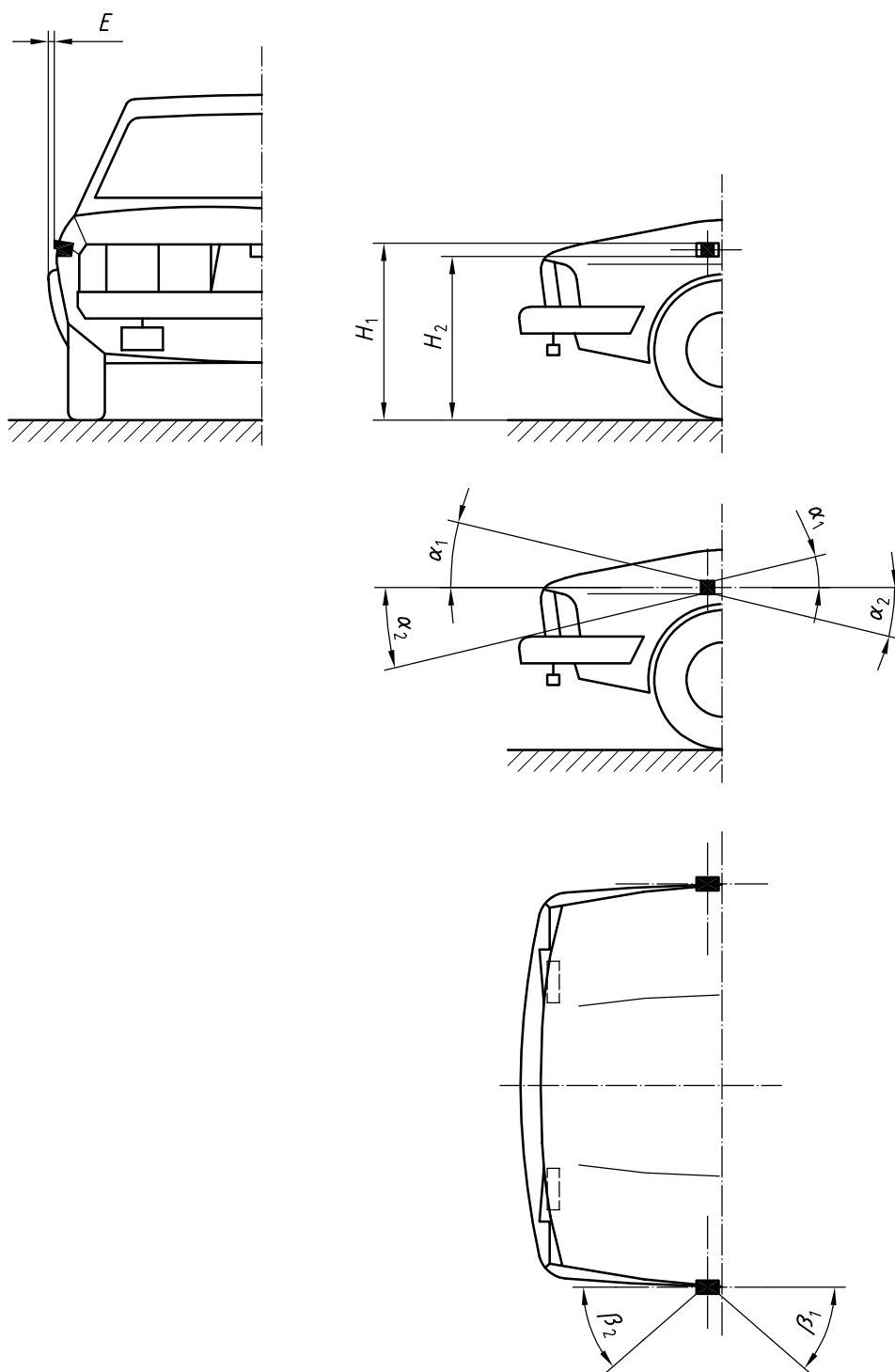

Figure E.6 — Parking lamp

E.6.2 Application

For motor vehicles only.

E.6.3 Number

Two.

E.6.4 Dimensions (in millimetres)

H_1 : unspecified

H_2 : unspecified

D : unspecified

$E \leq 400$

E.6.5 Minimum angles of geometric visibility

α_1 : 15°

α_2 : 15° (5° if $H_2 < 750$ mm)

β_1 : 45°

β_2 : 45°

E.6.6 Electrical connections

The connection shall allow parking lamps on the same side of the vehicle to be lit independently of any other lamps. Alternatively, lamps may be made functional by simultaneously switching on front and rear position lamps on the same side of the vehicle.

E.7 Front direction indicator lamp

E.7.1 Layout

See Figure E.7.

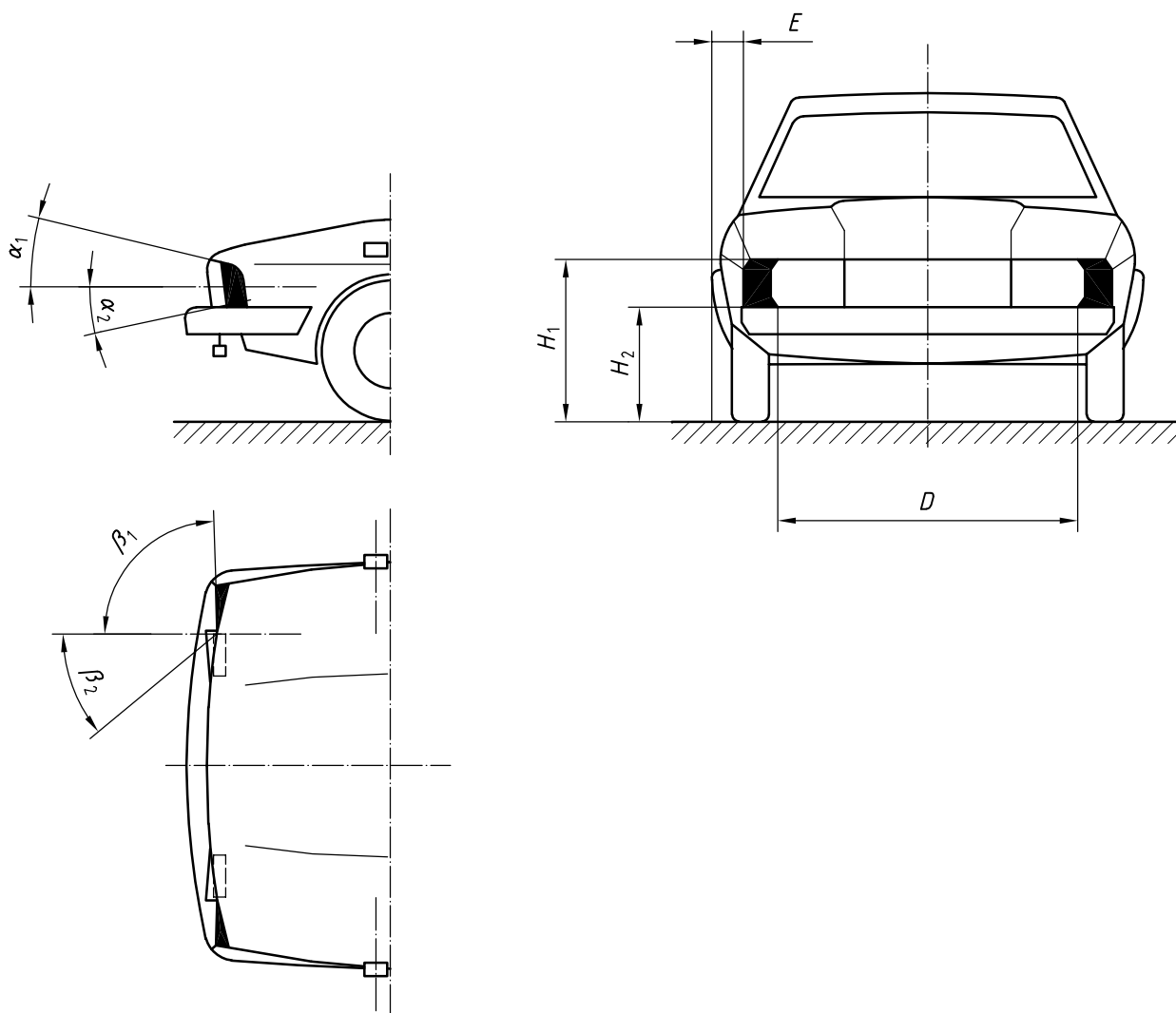

Figure E.7 — Front direction indicator lamp

E.7.2 Application

For motor vehicles only.

E.7.3 Number

Two.

E.7.4 Dimensions (in millimetres)

$$H_1 \leq 1\,500 \text{ (or } 2\,100 \text{ if the structure prevents compliance with } 1\,500)$$

$$H_2 \geq 350$$

$$D \geq 600$$

$$E \leq 400$$

E.7.5 Minimum angles of geometric visibility

$$\alpha_1: 15^\circ$$

$$\alpha_2: 15^\circ \text{ (} 5^\circ \text{ if } H_2 < 750 \text{ mm)}$$

$$\beta_1: 80^\circ \text{ (or } 45^\circ \text{ if flashing front side marker lamps are installed on the vehicle)}$$

$$\beta_2: 45^\circ$$

E.7.6 Electrical connections

Direction indicator lamps shall be switched on independently of the other lamps. All direction indicator lamps on one side of a vehicle shall be switched on and off by means of a single control and shall flash in phase. Side marker lamps may also flash at the same frequency (in or out of phase) as the front and rear direction indicators, when a side direction indicator lamp is not installed.

E.7.7 Special provisions

Consideration should be given to separating the front direction indicator from the passing beam/front fog lamp. Reference may be made to ISO/TR 10603 and ISO/TR 9819.

E.7.8 Other requirements and recommendations

- a) A flasher unit in accordance with ISO 4082 should be used.
- b) If the motor vehicle is authorized to draw a trailer, the control of the direction indicator lamps on the towing vehicle shall also operate the indicator lamps of the trailer.
- c) In the event of failure, other than short circuit, of one of the direction indicator lamps, the other(s) shall continue to flash, while the frequency under this condition may be different from that specified.
- d) "Hazard warning signal" means the simultaneous operation of at least front and rear vehicle direction indicators. If a trailer is being used, its direction indicator lamp shall also operate simultaneously. The hazard warning signal shall be able to function even though the "on-off" device of the engine is in a position which makes it impossible to run the engine.

E.8 Side direction indicator lamp

E.8.1 Layout

See Figure E.8.

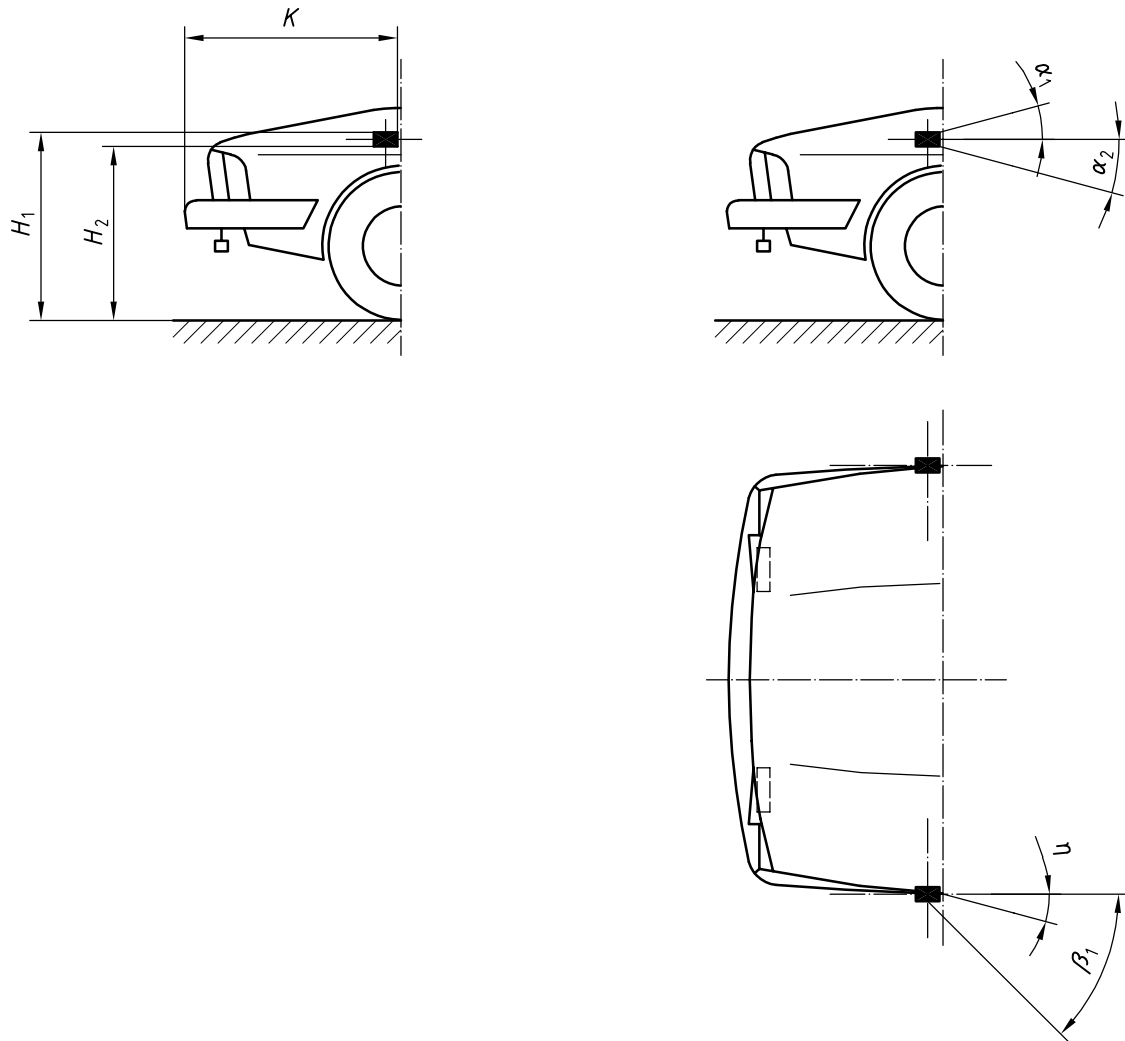

Figure E.8 — Side direction indicator lamp

E.8.2 Application

For motor vehicles only.

E.8.3 Number

Two.

E.8.4 Dimensions (in millimetres)

$H_1 \leq 1\,500$ (or 2 300 if the structure prevents compliance with 1 500)

$H_2 \geq 350$

$K \leq 1\,800$ (or 2 500 if the structure of the vehicle prevents compliance with the minimum angles of geometric visibility)

E.8.5 Minimum angles of geometric visibility

See Table E.2.

Table E.2 — Minimum angles of geometric visibility

Units in degrees

Passenger cars ^a	Commercial and public service vehicles ^a
α_1 : 15	α_1 : 30
α_2 : 15 (5 if $H_2 < 750$ mm)	α_2 : 5
β_1 : 60	β_1 : 60
η : 5	η : 5
NOTE The value η given for the dead angle of visibility to the rear of the repeating side indicator is an upper limit.	
^a See ISO 3833 for definitions.	

E.8.6 Electrical connections

Direction indicator lamps shall be switched on independently of the other lamps. All direction indicator lamps on one side of a vehicle shall be switched on and off by means of a single control and shall flash in phase. Side marker lamps may also flash at the same frequency (in or out of phase) as the front and rear direction indicators, when a side direction indicator lamp is not installed.

E.8.7 Special provision

Reference may be made to ISO/TR 10603 and ISO/TR 9819.

E.8.8 Other requirements and recommendations

- a) A flasher unit in accordance with ISO 4082 should be used.
- b) If the motor vehicle is authorized to draw a trailer, the control of the direction indicator lamps on the towing vehicle shall also operate the indicator lamps of the trailer.
- c) In the event of failure, other than short circuit, of one of the direction indicator lamps, the other(s) shall continue to flash, while the frequency under this condition may be different from that specified.
- d) "Hazard warning signal" means the simultaneous operation of at least front and rear vehicle direction indicators. If a trailer is being used, its direction indicator lamp shall also operate simultaneously. The hazard warning signal shall be able to function even though the "on/off" device of the engine is in a position which makes it impossible to run the engine.

E.9 Rear direction indicator lamp

E.9.1 Layout

See Figure E.9.

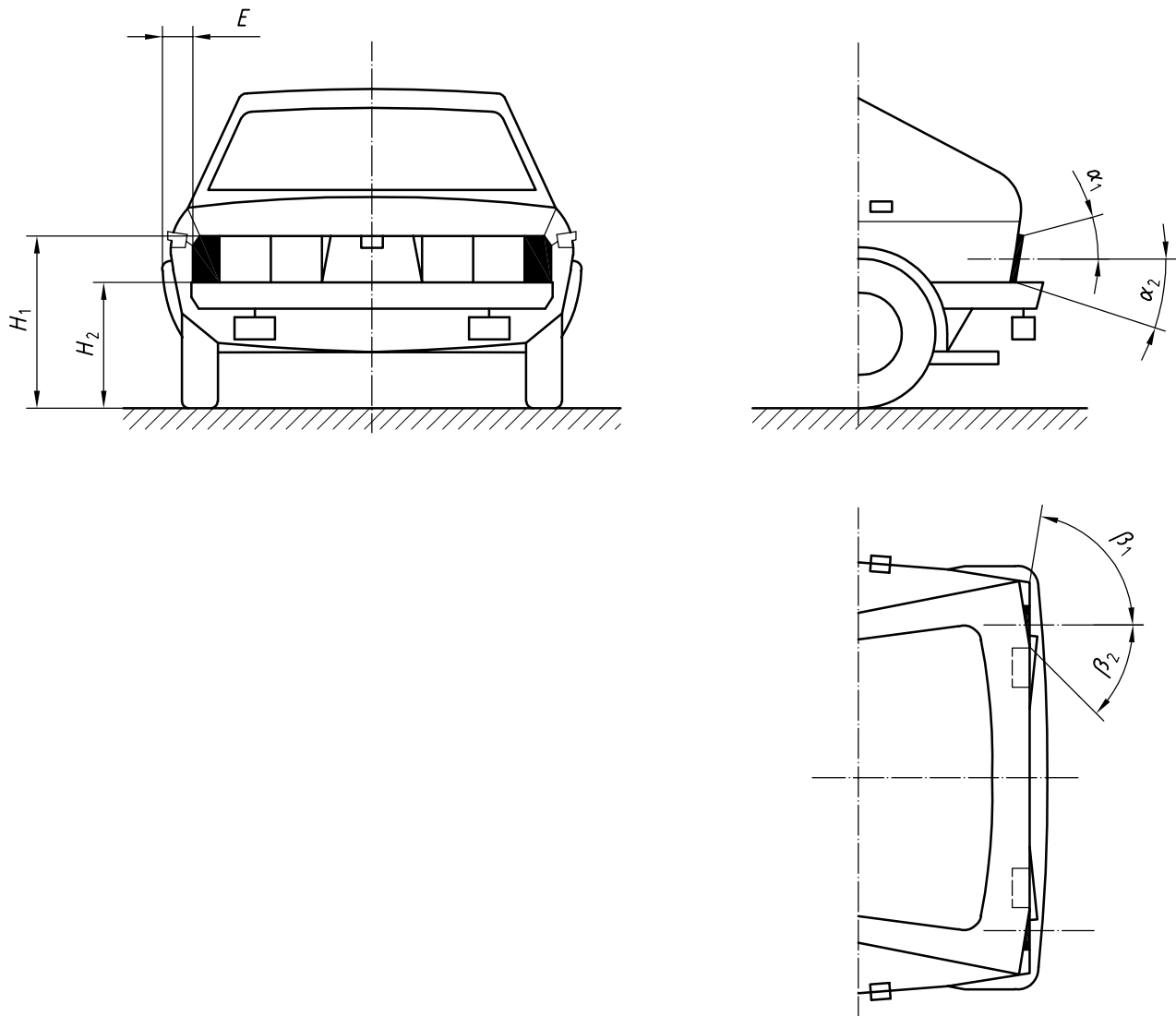

Figure E.9 — Rear direction indicator lamp

E.9.2 Application

For motor vehicles and trailers.

E.9.3 Number

Two or four (except for single lamp).

E.9.4 Dimensions (in millimetres)

$H_1 \leq 1\,500$ (or 2 100 if the structure prevents compliance with 1 500)

$H_2 \geq 350$

$D \geq 600$

$E \leq 400$

E.9.5 Minimum angles of geometric visibility

α_1 : 15°

α_2 : 15° (5° if $H_2 < 750$ mm)

β_1 : 80° (or 45° if flashing rear side marker lamps are installed on the vehicle)

β_2 : 45°

E.9.6 Electrical connections

Direction indicator lamps shall be switched on independently of the other lamps. All direction indicator lamps on one side of a vehicle shall be switched on and off by means of a single control and shall flash in phase. Side marker lamps may also flash at the same frequency (in or out of phase) as the front and rear direction indicators, when a side direction indicator lamp is not installed.

E.9.7 Other requirements and recommendations

- a) A flasher unit in accordance with ISO 4082 should be used.
- b) If the motor vehicle is authorized to draw a trailer, the control of the direction indicator lamps on the towing vehicle shall also operate the indicator lamps of the trailer.
- c) In the event of failure, other than short circuit, of one of the direction indicator lamps, the other(s) shall continue to flash, while the frequency under this condition may be different from that specified.
- d) "Hazard warning signal" means the simultaneous operation of at least front and rear vehicle direction indicators. If a trailer is being used, its direction indicator lamp shall also operate simultaneously. The hazard warning signal shall be able to function even though the "on/off" device of the engine is in a position which makes it impossible to run the engine.

E.10 Stop lamp

E.10.1 Layout

See Figure E.10.

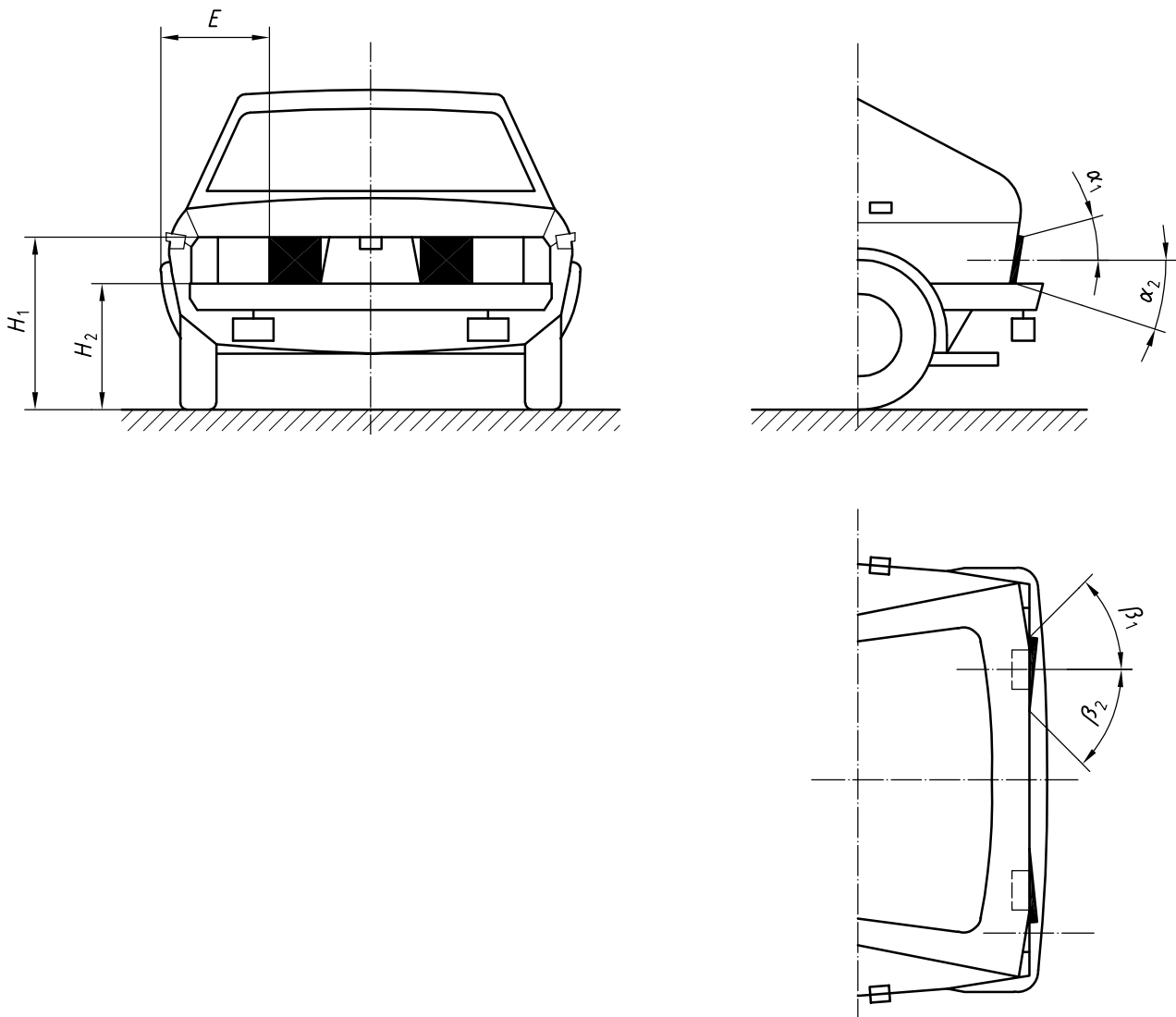

Figure E.10 — Stop lamp

E.10.2 Application

For motor vehicles and trailers.

E.10.3 Number

Two or four (except for single lamp).

E.10.4 Dimensions (in millimetres)

$$H_1 \leq 1\,500 \text{ (or } 2\,100 \text{ if the structure prevents compliance with } 1\,500\text{)}$$

$$H_2 \geq 350$$

$$E \leq 400$$

E.10.5 Minimum angles of geometric visibility

$$\alpha_1: 15^\circ$$

$$\alpha_2: 15^\circ \text{ (} 5^\circ \text{ if } H_2 < 750 \text{ mm)}$$

$$\beta_1: 80^\circ \text{ (or } 45^\circ \text{ if flashing rear side marker lamps are installed on the vehicle)}$$

$$\beta_2: 45^\circ$$

E.10.6 Electrical connections

The stop lamp shall light up when the service brake is applied. The stop lamp need not function if the device which starts or stops the engine, or both, is in a position that makes it impossible for the engine to operate.

The stop lamp may be activated by the application of a retarder or similar device.

E.10.7 Special provision

In all cases, the distance between the stop lamp and the rear fog lamp shall be greater than 100 mm.

E.11 Stop lamp (centre high-mounted)

E.11.1 Layout

See Figure E.11.

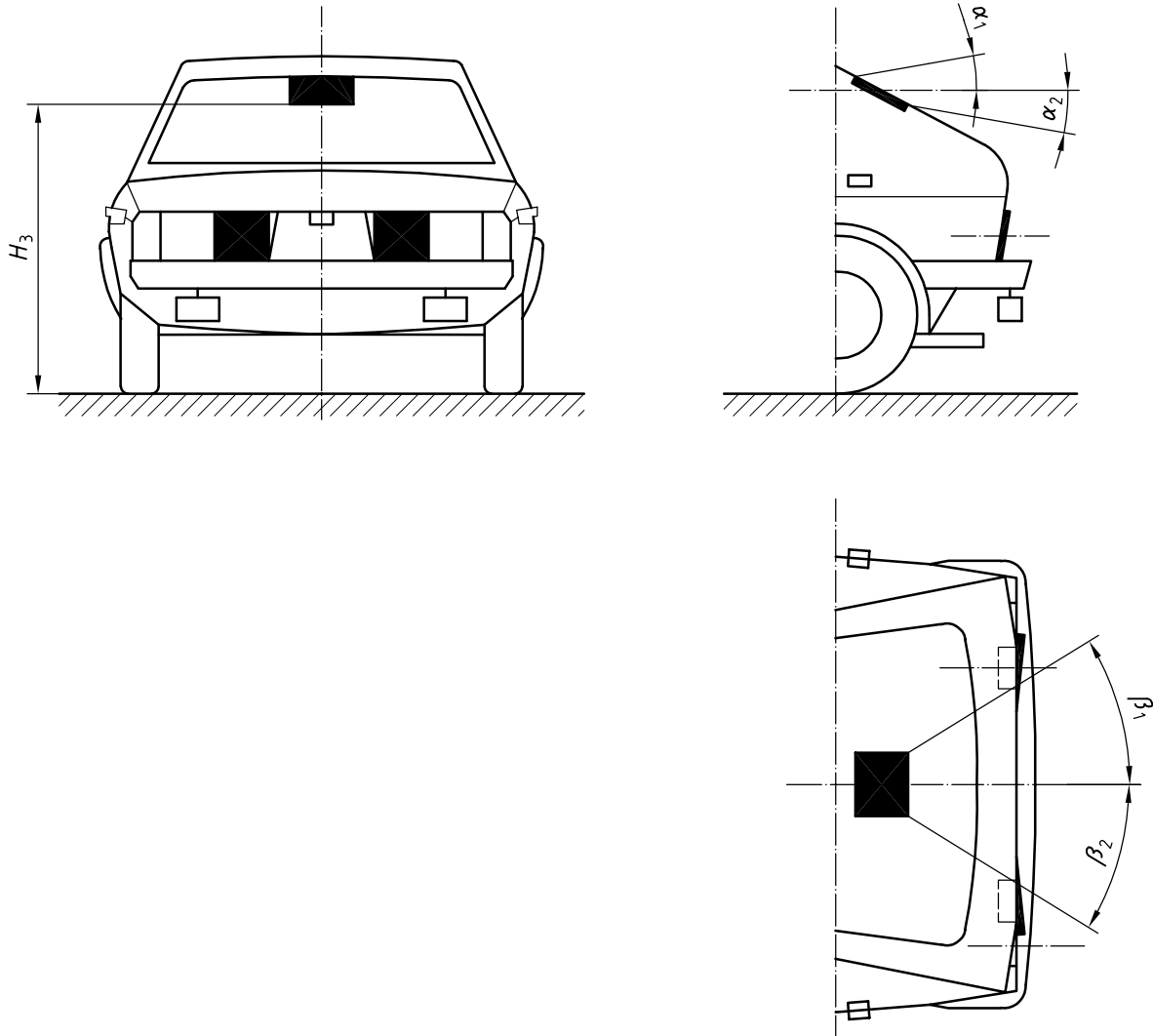

Figure E.11 — Stop lamp (centre high-mounted)

E.11.2 Application

For motor vehicles only.

E.11.3 Number

One — except when the longitudinal median plane of the vehicle is not located on a fixed body panel, but separates one or two movable parts of the vehicle (e.g. doors), and thus sufficient space is lacking for the installation of a single device on the longitudinal median plane above such movable parts. Then, and only then, either of the following may be installed:

- a) two devices;
- b) a single device offset to the left or to the right of the longitudinal median plane.

E.11.4 Dimensions

E.11.4.1 Width

The reference centre shall normally be situated on the longitudinal median plane of the vehicle.

However, when two devices are installed, they shall be positioned as close as possible to the longitudinal median plane, one on each side of this plane.

When a single device offset from the longitudinal median plane is installed, this offset shall not exceed 150 mm from the longitudinal median plane to the reference centre of the lamp.

E.11.4.2 H_3

The horizontal plane tangential to the lower edge of the apparent surface shall be either

- not more than 150 mm below the horizontal plane tangential to the lower edge of the exposed surface of the glass or glazing of the rear window, or
- not less than 850 mm above the ground.

However, the horizontal plane tangential to the lower edge of the apparent surface of the centre high-mounted stop lamp shall be at least above the horizontal plane tangential to the upper edge of the apparent surface of the standard stop lamps.

E.11.5 Minimum angles of geometric visibility

$$\alpha_1: 10^\circ$$

$$\alpha_2: 5^\circ$$

$$\beta_1: 10^\circ$$

$$\beta_2: 10^\circ$$

E.11.6 Electrical connections

The centre high-mounted stop lamp shall light up when the service brake is applied. The lamp need not function if the device which starts or stops the engine, or both, is in a position that makes it impossible for the engine to operate.

The centre high-mounted stop lamp may be activated by the application of a retarder or a similar device.

E.12 Rear position lamp

E.12.1 Layout

See Figure E.12.

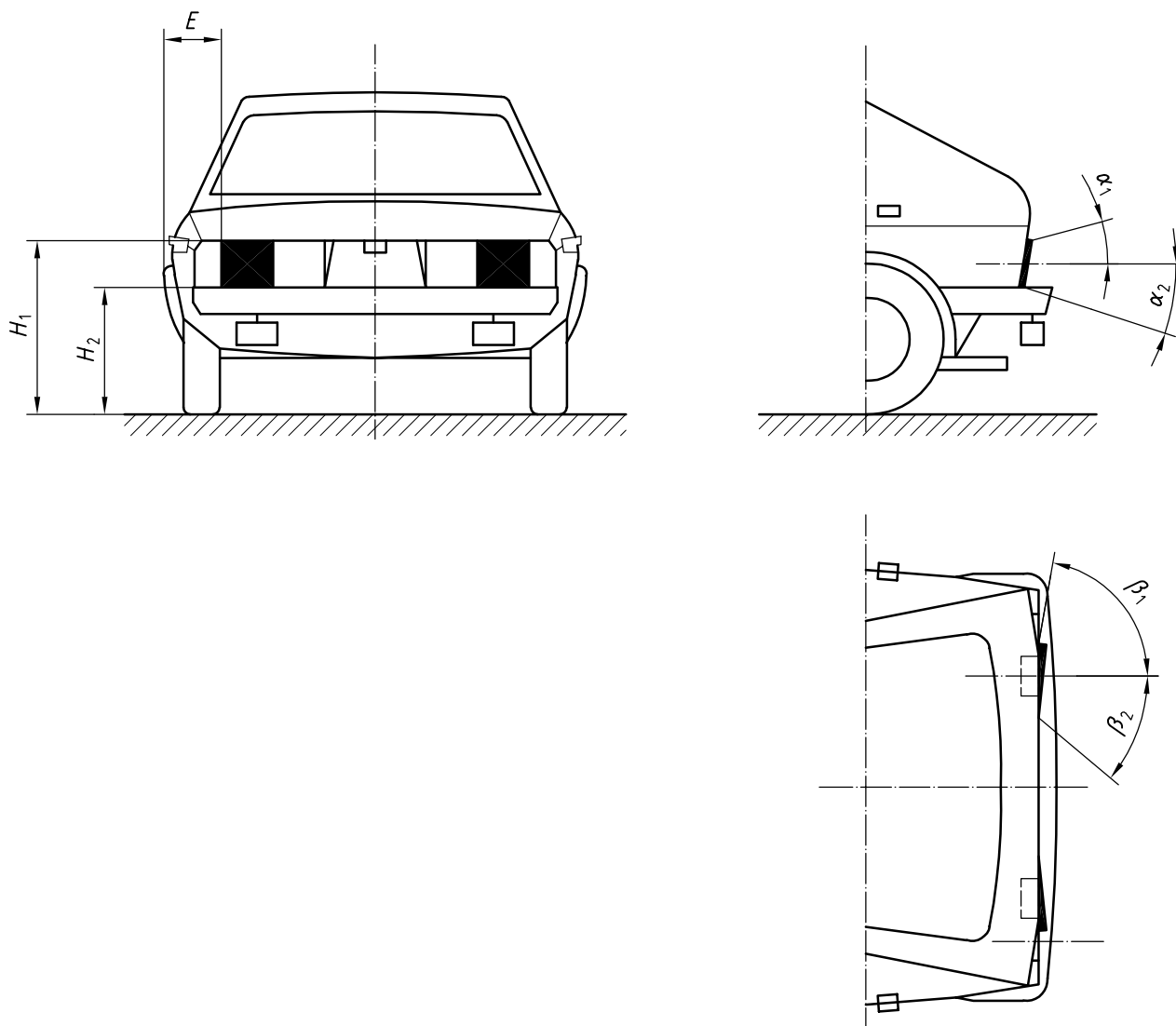

Figure E.12 — Rear position lamp

E.12.2 Application

For motor vehicles and trailers.

E.12.3 Number

Two or four (except for single lamp).

E.12.4 Dimensions (in millimetres)

$$H_1 \leq 1\,500 \text{ (or } 2\,100 \text{ if the structure prevents compliance with } 1\,500\text{)}$$

$$H_2 \geq 350$$

$$E \leq 400$$

E.12.5 Minimum angles of geometric visibility

$$\alpha_1: 15^\circ$$

$$\alpha_2: 15^\circ \text{ (} 5^\circ \text{ if } H_2 < 750 \text{ mm)}$$

$$\beta_1: 80^\circ \text{ (or } 45^\circ \text{ if side marker lamps are installed on the vehicle)}$$

$$\beta_2: 45^\circ$$

E.12.6 Electrical connections

See 4.13. The rear position lamps may be switched on at the same time as the daytime running lamps.

E.13 Rear fog lamp

E.13.1 Layout

See Figure E.13.

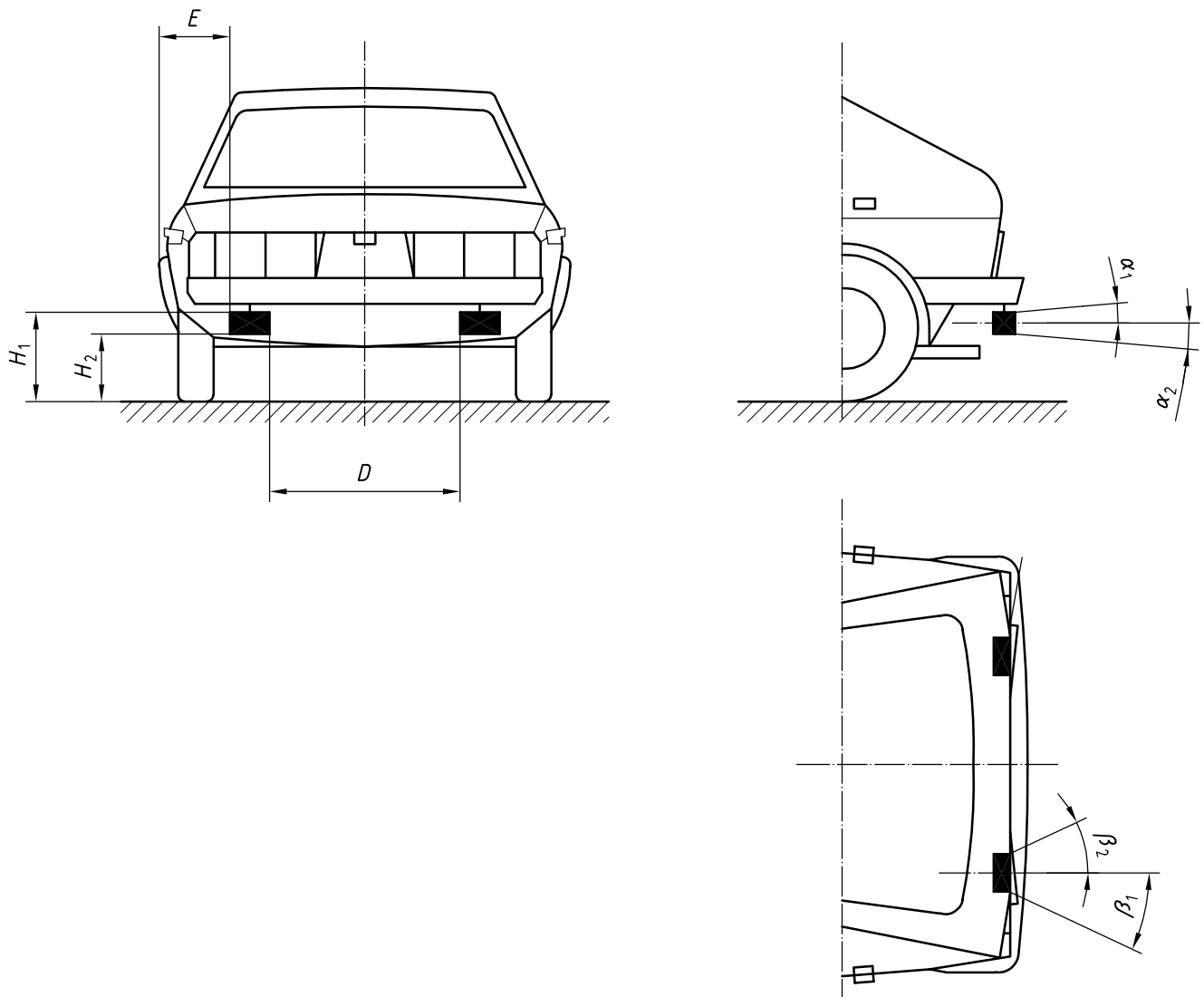

Figure E.13 — Rear fog lamp

E.13.2 Application

For motor vehicles and trailers.

E.13.3 Number

One or two.

E.13.4 Dimensions (in millimetres)

$$H_1 \leq 1000$$

$$H_2 \geq 250$$

D: unspecified

E: unspecified

E.13.5 Minimum angles of geometric visibility

$$\alpha_1: 5^\circ$$

$$\alpha_2: 5^\circ$$

$$\beta_1: 25^\circ$$

$$\beta_2: 25^\circ$$

E.13.6 Electrical connections

These shall be such that the rear fog lamp or lamps

- cannot be switched on unless the main beams, dipped beams or front fog lamps are lit, and
- can be switched off independently of any other lamp.

The rear fog lamp or lamps shall be able to continue to operate until the position lamps are switched off, and shall then remain off until deliberately switched on again. Alternatively, when the rear fog lamp switch is in the “on” position, a warning that is at least audible and which is additional to the mandatory telltale shall be given if the ignition is switched off or the ignition key is withdrawn and the driver’s door is opened — regardless of whether the main-beam headlamp, dipped-beam headlamp or front fog lamps are on or off.

Other than these provisions, operation of a rear fog lamp shall not be affected by switching on or off any other lamps.

If there is only one rear fog lamp, it shall be on the side of the longitudinal median plane of the vehicle opposite to the direction of traffic prescribed in the country of registration. The reference centre may also be situated on the median longitudinal plane of the vehicle.

E.13.7 Special provision

In all cases, the distance between the rear fog lamp and the stop lamp shall be greater than 100 mm.

E.14 Reversing lamp

E.14.1 Layout

See Figure E.14.

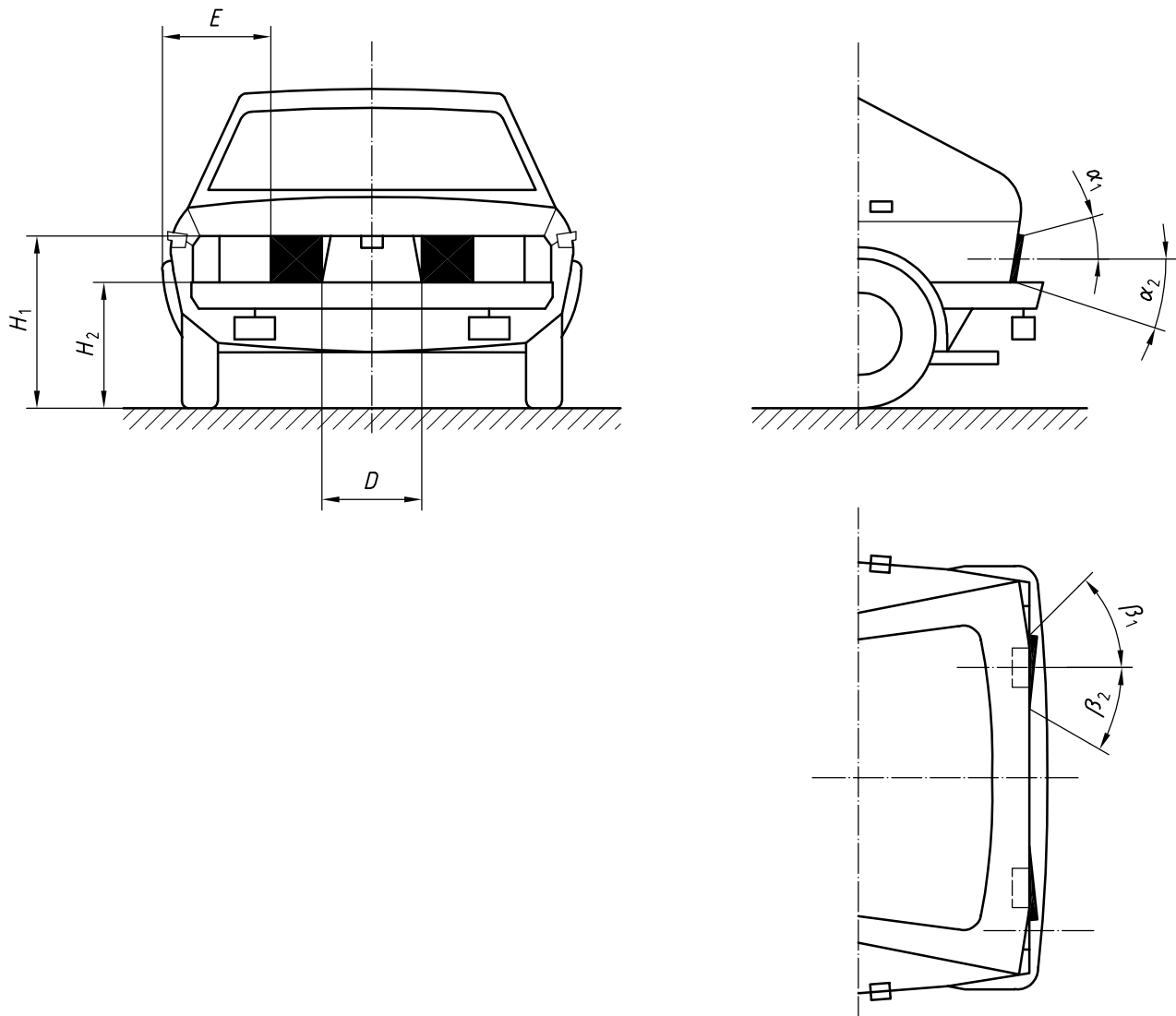

Figure E.14 — Reversing lamp

E.14.2 Application

For motor vehicles and trailers.

E.14.3 Number

One or two.

E.14.4 Dimensions (in millimetres)

$$H_1 \leq 1\,200$$

$$H_2 \geq 250$$

D: unspecified

E: unspecified

E.14.5 Minimum angles of geometric visibility

$$\alpha_1: 15^\circ$$

$$\alpha_2: 15^\circ$$

$$\beta_1: 45^\circ$$

$$\beta_2: 45^\circ \text{ (30^\circ for two lamps)}$$

E.14.6 Electrical connections

These shall be such that the reversing lamp can light up only if the reverse gear is engaged and if the device controlling the starting and stopping of the engine is in a position where operation of the engine is possible. The reversing lamp shall not light up or remain lit if either of the above conditions is not satisfied.

E.15 Rear registration plate lamp**E.15.1 Layout**

See Figure E.15.

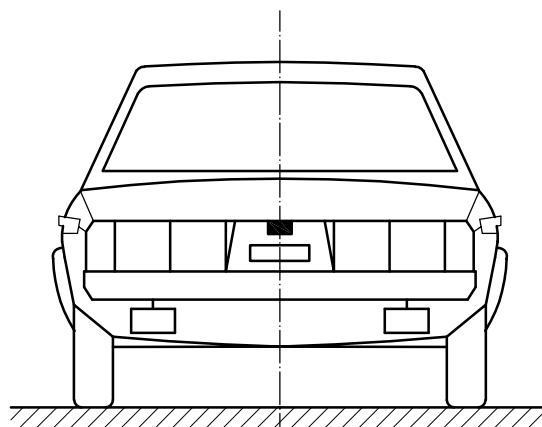

Figure E.15 — Rear registration plate lamp

E.15.2 Application

For motor vehicles and trailers.

E.15.3 Number

One.

E.15.4 Dimensions

Width, height and length shall be such that the device illuminates the area of the registration plate.

E.15.5 Position

The manufacturer of the device shall specify the position in which the device is to be fitted, in relation to the space for the registration plate.

The device shall be so designed that no light is emitted directly towards the rear, with the exception of red light if the device is combined or grouped with a rear lamp.

E.15.6 Electrical connections

See 4.13. The device shall illuminate only at the same time as rear position lamps.

E.16 Rear retro-reflector (non-triangular)

E.16.1 Layout

See Figure E.16.

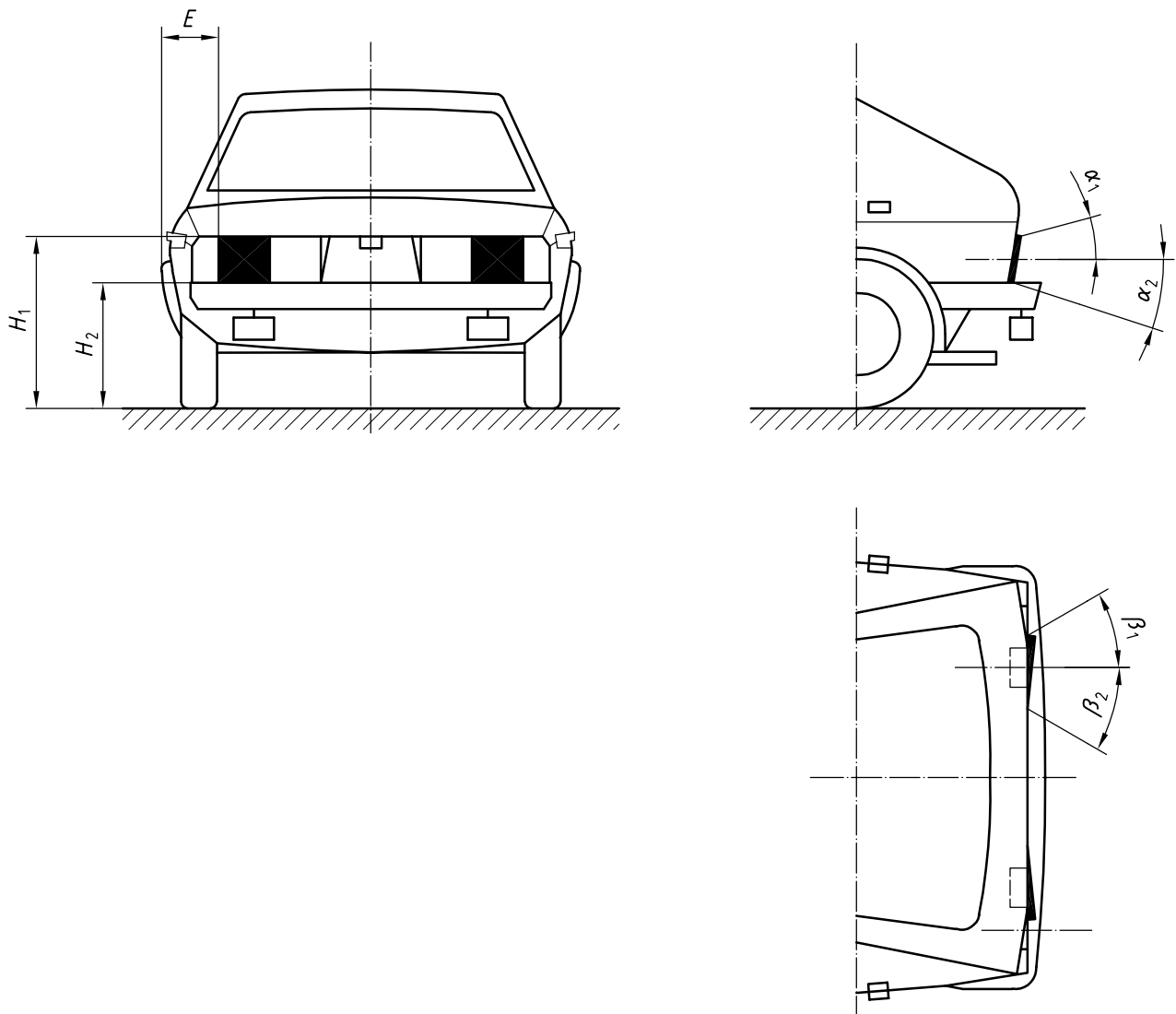

Figure E.16 — Non-triangular rear retro-reflector

E.16.2 Application

For motor vehicles only.

E.16.3 Number

Two — however, additional retro-reflecting devices and materials are permitted, provided they do not impair the effectiveness of other lighting and light signalling devices.

E.16.4 Dimensions (in millimetres)

$$H_1 \leq 900 \text{ (or 1 500 if the shape of the bodywork prevents compliance with 900)}^2)$$

$$H_2 \geq 250$$

$$E \leq 400^2)$$

E.16.5 Minimum angles of geometric visibility

$$\alpha_1: 15^\circ$$

$$\alpha_2: 15^\circ \text{ (5}^\circ \text{ if } H_2 < 750 \text{ mm)}$$

$$\beta_1: 30^\circ$$

$$\beta_2: 30^\circ$$

E.16.6 Shape

Non-triangular.

E.16.7 Configuration

The illuminating surface of the retro-reflector may have parts in common with the apparent surface of any other rear lamp.

2) Value applies to minimum retro-reflector only.

E.17 Side retro-reflector (front and rear)

E.17.1 Layout

See Figure E.17.

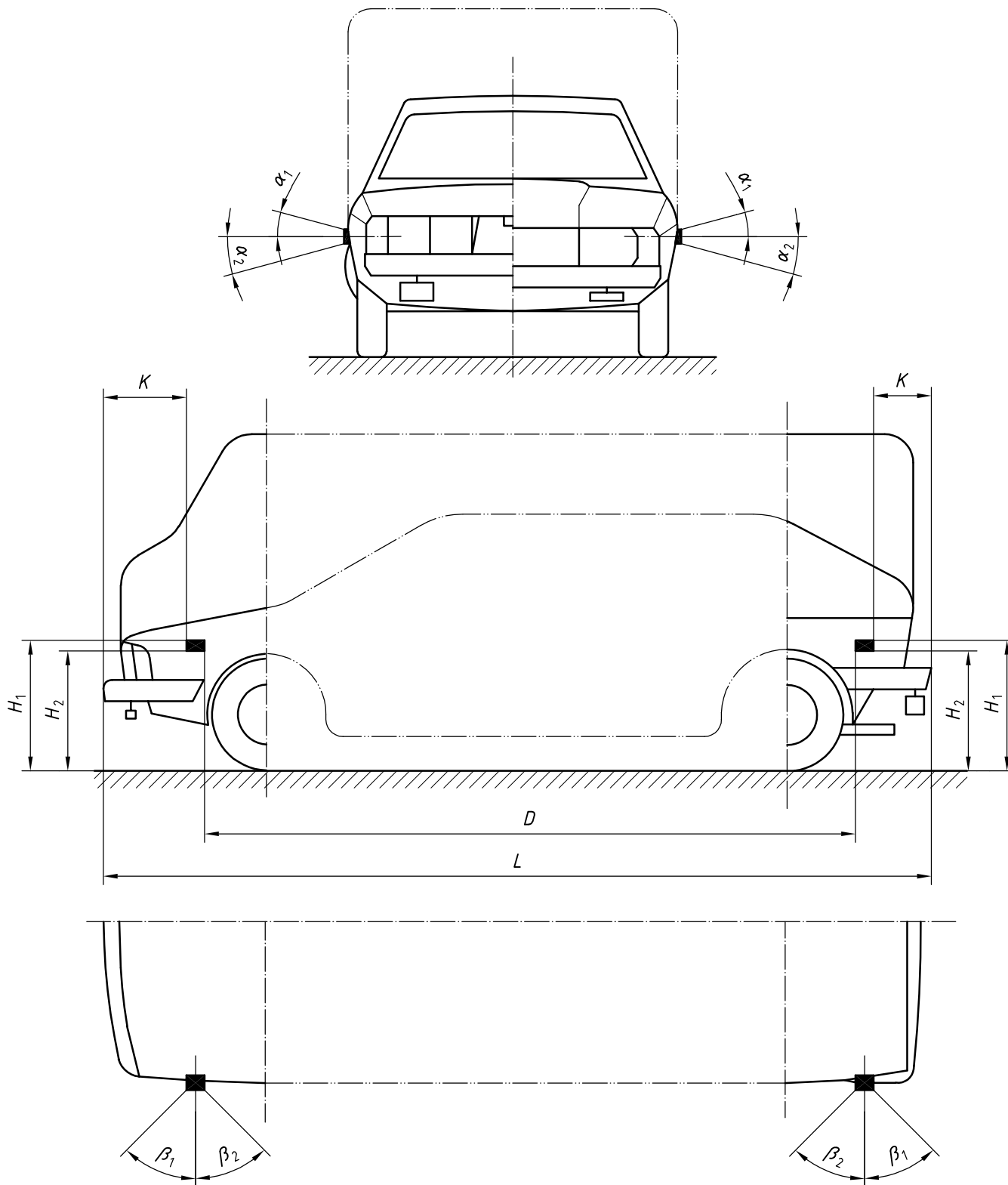

Figure E.17 — Front and rear side retro-reflectors

E.17.2 Application

For motor vehicles and trailers.

E.17.3 Number

Two front, two rear.

E.17.4 Dimensions (in millimetres)

$H_1 \leq 900$ (or 1 500 if the structure of the vehicle prevents compliance with 900)

$H_2 \geq 350$

D : unspecified

K : front — foremost reflex-reflector shall be no further than 3 m from front (in the case of trailers, inclusive of the drawbar)

K : rear — distance between rearmost reflex-reflector and rear of vehicle shall not exceed 1 m.

E.17.5 Minimum angles of geometric visibility

α_1 : 15°

α_2 : 15° (5° if $H_2 < 750$ mm)

β_1 : 45°

β_2 : 45°

E.17.6 Shape

Non-triangular.

E.17.7 Configuration

The illuminating surface of the retro-reflector may have parts in common with the apparent surface of any other lamp situated at the side.

E.18 Side marker lamp (front and rear)

E.18.1 Layout

See Figure E.18.

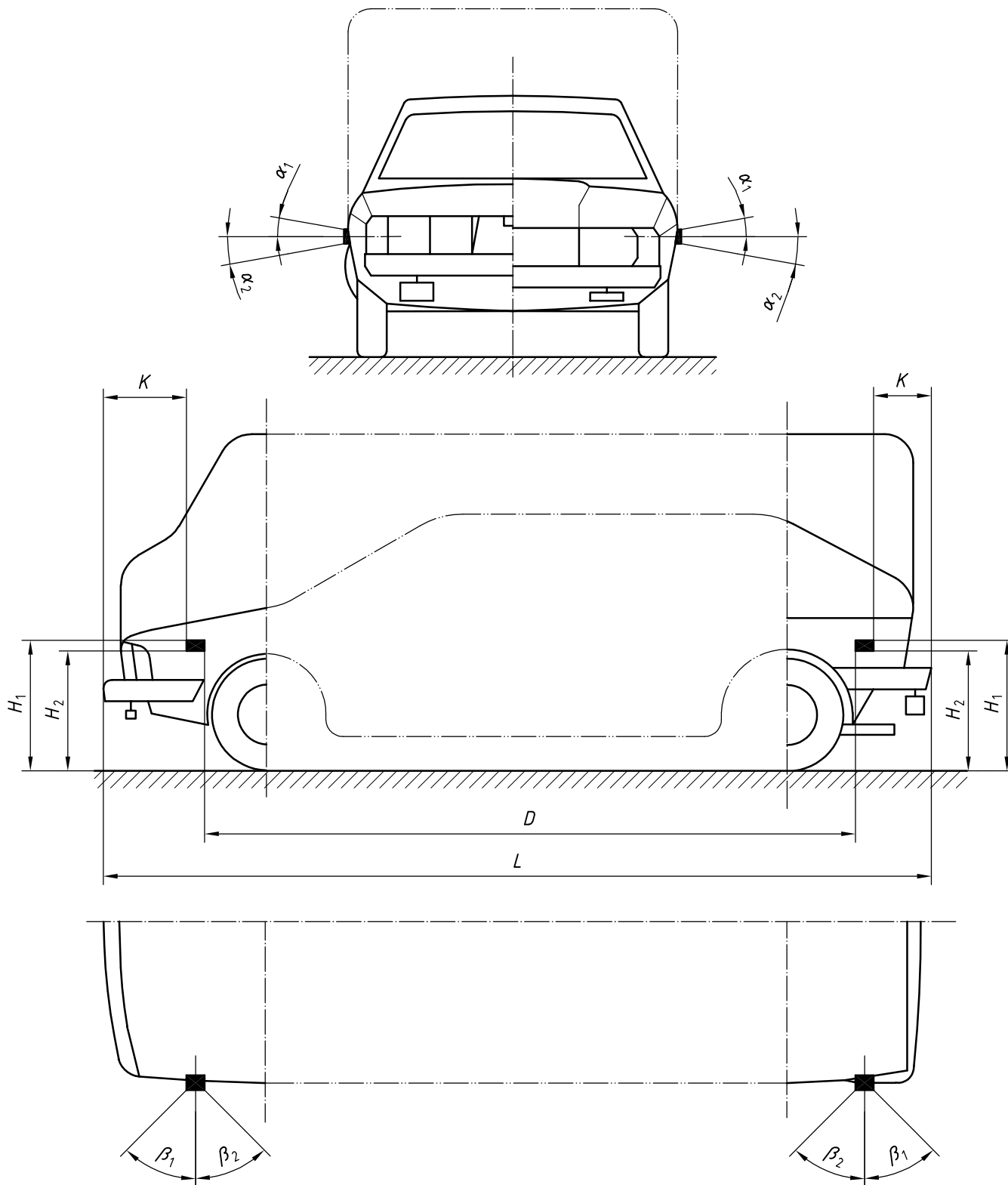

Figure E.18 — Front and rear side marker lamps

E.18.2 Application

For motor vehicles and trailers.

E.18.3 Number

Two front, two rear.

E.18.4 Dimensions (in millimetres)

$H_1 \leq 1\,500$ (or 2 100 if the shape of the bodywork prevents compliance with 1 500)

$H_2 \geq 350$

D : unspecified

K : front — foremost reflex-reflector shall be no further than 3 m from front (in the case of trailers, inclusive of the drawbar)

K : rear — distance between rearmost reflex-reflector and rear of vehicle shall not exceed 1 m.

E.18.5 Minimum angles of geometric visibility

α_1 : 10°

α_2 : 10° (5° if $H_2 < 750$ mm)

β_1 : 45°

β_2 : 30° for passenger cars less than 6 m in length; 45° for all other vehicles and trailers

E.19 Side retro-reflector (intermediate)

E.19.1 Layout

See Figure E.19.

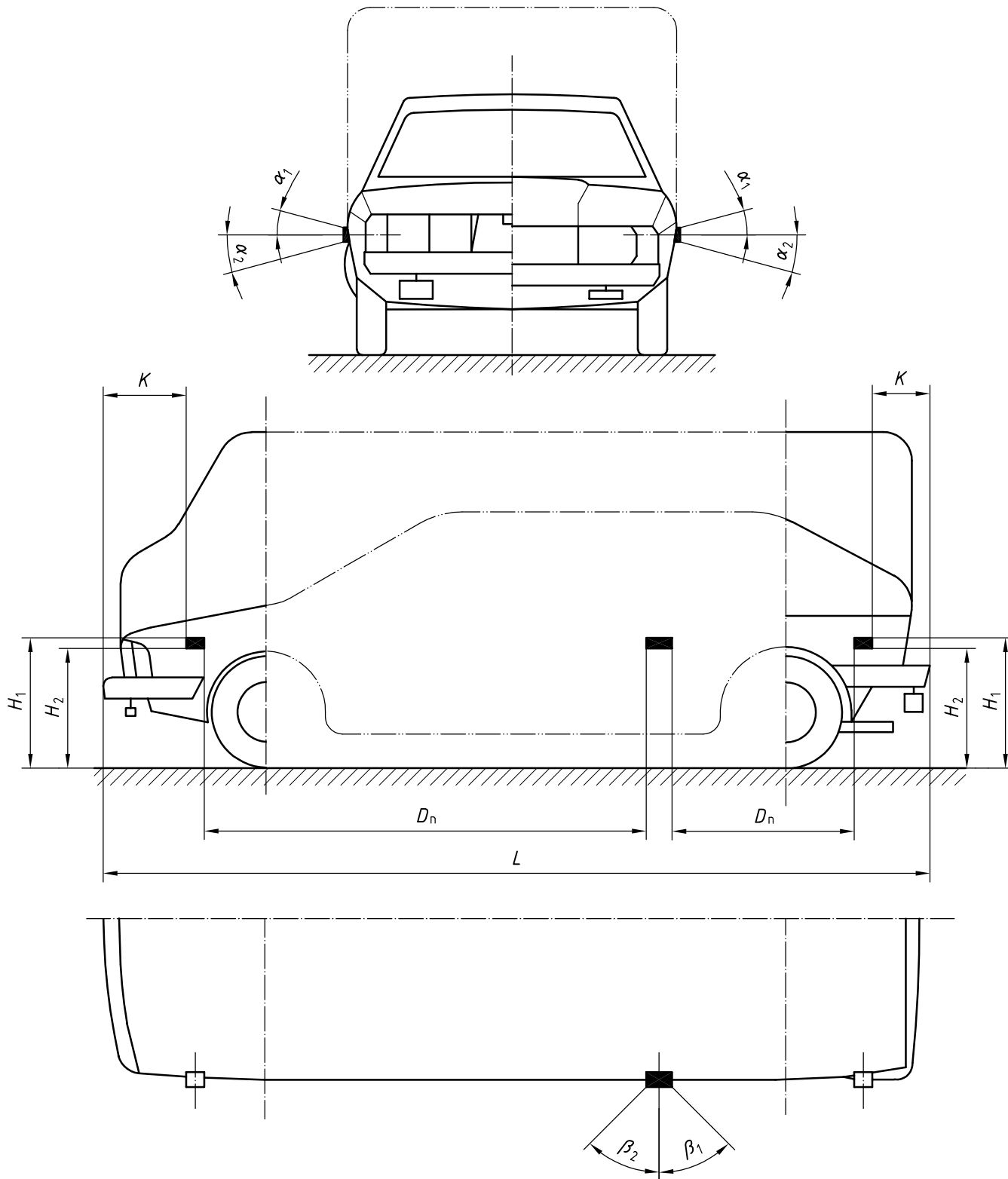

Figure E.19 — Intermediate side retro-reflector

E.19.2 Application

For motor vehicles and trailers exceeding 6 m in length.

E.19.3 Number

Such that D_n does not exceed 3 m.

E.19.4 Dimensions

D_n distance between two adjacent side retro-reflectors: it shall not exceed 3 m.

E.19.5 Minimum angles of geometric visibility

α_1 : 15°

α_2 : 15° (5° if $H_2 < 750$ mm)

β_1 : 45°

β_2 : 45°

E.19.6 Shape

Non-triangular.

E.19.7 Configuration

The illuminating surface of the side retro-reflector may have parts in common with the apparent surface of any other side lamp.

E.20 Side marker lamp (intermediate)

E.20.1 Layout

See Figure E.20.

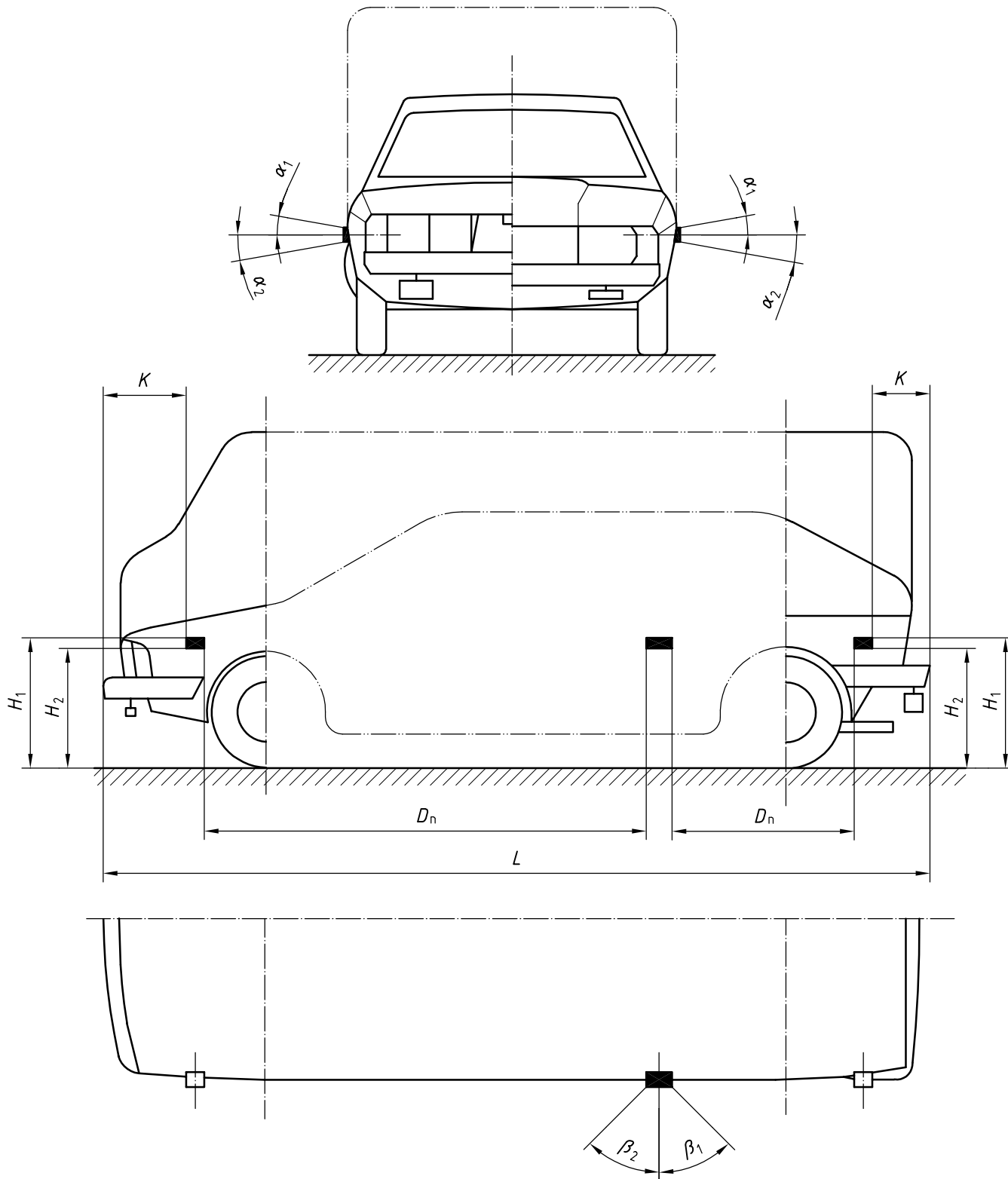

Figure E.20 — Intermediate side marker lamp

E.20.2 Application

For motor vehicles and trailers exceeding 6 m in length.

E.20.3 Number

Such that D_n does not exceed 3 m.

E.20.4 Dimensions

The distance between two adjacent side markers, D_n , shall not exceed 3 m.

E.20.5 Minimum angles of geometric visibility

α_1 : 10°

α_2 : 10° (5° if $H_2 < 750$ mm)

β_1 : 45°

β_2 : 45°

E.21 End-outline marker lamp (front and rear)

E.21.1 Layout

See Figure E.21.

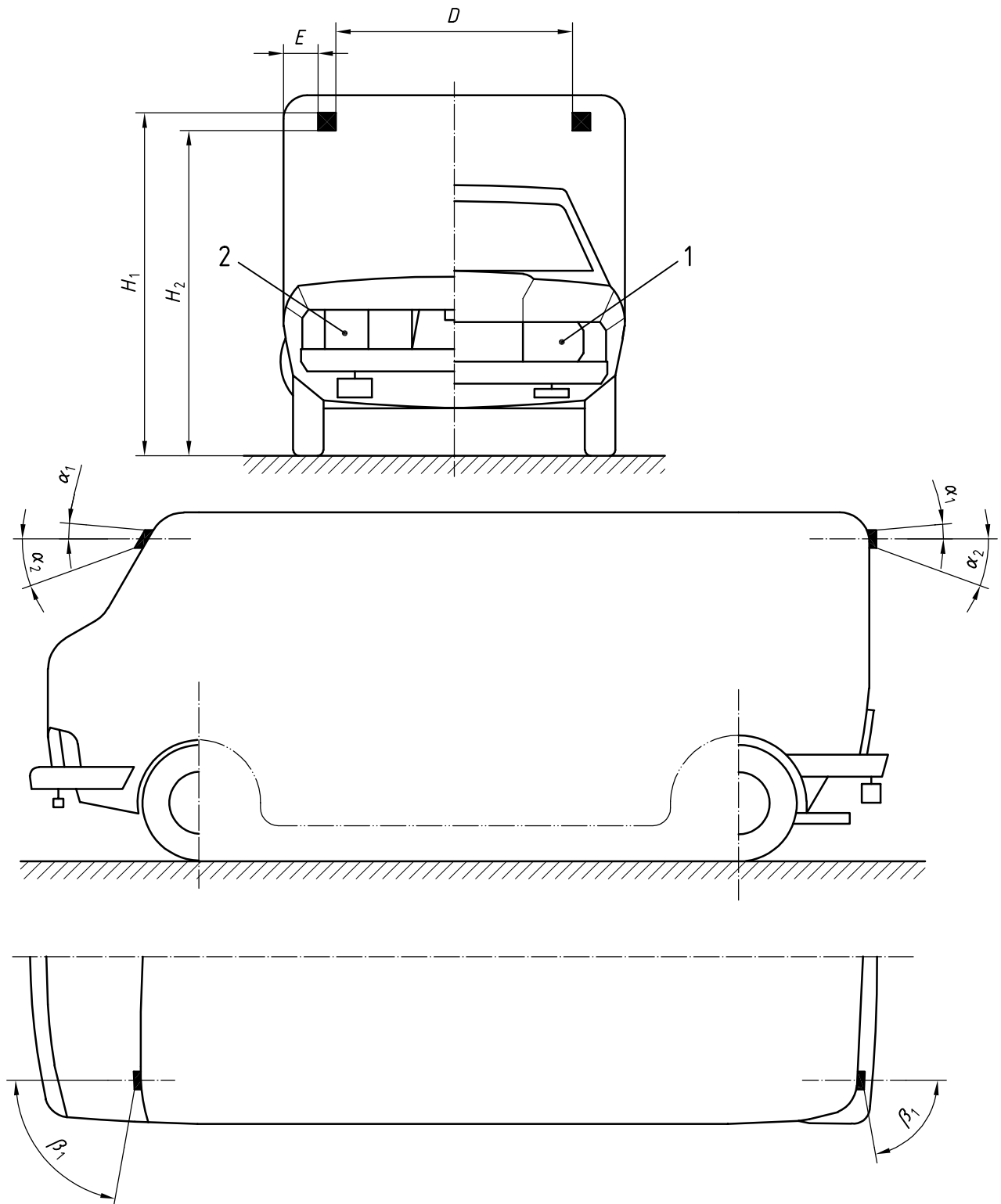

Key

- 1 Front
- 2 Rear

Figure E.21 — Front and rear end-outline marker lamps

E.21.2 Application

For motor vehicles, excluding passenger cars, and for trailers and semi-trailers.

E.21.3 Number

Two front, two rear.

E.21.4 Dimensions

E.21.4.1 Height

E.21.4.1.1 Front

E.21.4.1.1.1 Motor vehicles

The horizontal plane tangential to the upper edge of the apparent surface in the direction of the reference axis of the device shall not be lower than the horizontal plane tangential to the upper edge of the transparent zone of the wind-screen.

E.21.4.1.1.2 Trailers and semi-trailers

The maximum height shall be compatible with the requirements relating to the width, design and operational requirements of the vehicle and to the symmetry of the lamps.

E.21.4.1.2 Rear

The maximum height shall be compatible with the requirements relating to the width, design and operational requirements of the vehicle and to the symmetry of the lamps.

E.21.4.2 Width

At both front and rear, this shall extend as close as possible to the extreme outer edge of the vehicle. This requirement is deemed to have been met when the point on the apparent surface in the direction of the reference axis farthest from the vehicle's longitudinal median plane is not more than 400 mm from the extreme outer edge of the vehicle.

E.21.5 Minimum angles of geometric visibility

$$\alpha_1: 5^\circ$$

$$\alpha_2: 20^\circ$$

$$\beta_1: 80^\circ$$

$$\beta_2: 0^\circ$$

E.21.6 Configuration

Provided that all other requirements are met, the lamp visible from the front and the lamp visible from the rear on the same side of the vehicle may be combined in one device.

The position of an end-outline marker lamp in relation to a corresponding position lamp shall be such that the distance between the projections on a transverse vertical plane of the points nearest to one another on the apparent surface in the direction of the respective reference axes of the two lamps is not less than 200 mm.

E.22 Identification lamp (front and rear)

E.22.1 Layout

See Figure E.22.

E.22.2 Application

For motor vehicles, excluding passenger cars, and for trailers.

E.22.3 Number

Three front, three rear.

E.22.4 Dimensions

H_1 : as close as practicable to the top of the vehicle

H_2 : as close as practicable to the top of the vehicle

E : as close as practicable to vertical centreline

D : $150 \text{ mm} \leq D \leq 310 \text{ mm}$

where D is measured between the centres of the lamps.

E.22.5 Minimum angles of geometric visibility

α_1 : 10°

α_2 : 10°

β_1 : 45°

β_2 : 45°

E.22.6 Configuration

An identification lamp shall not be grouped, combined or reciprocally incorporated with other lamps.

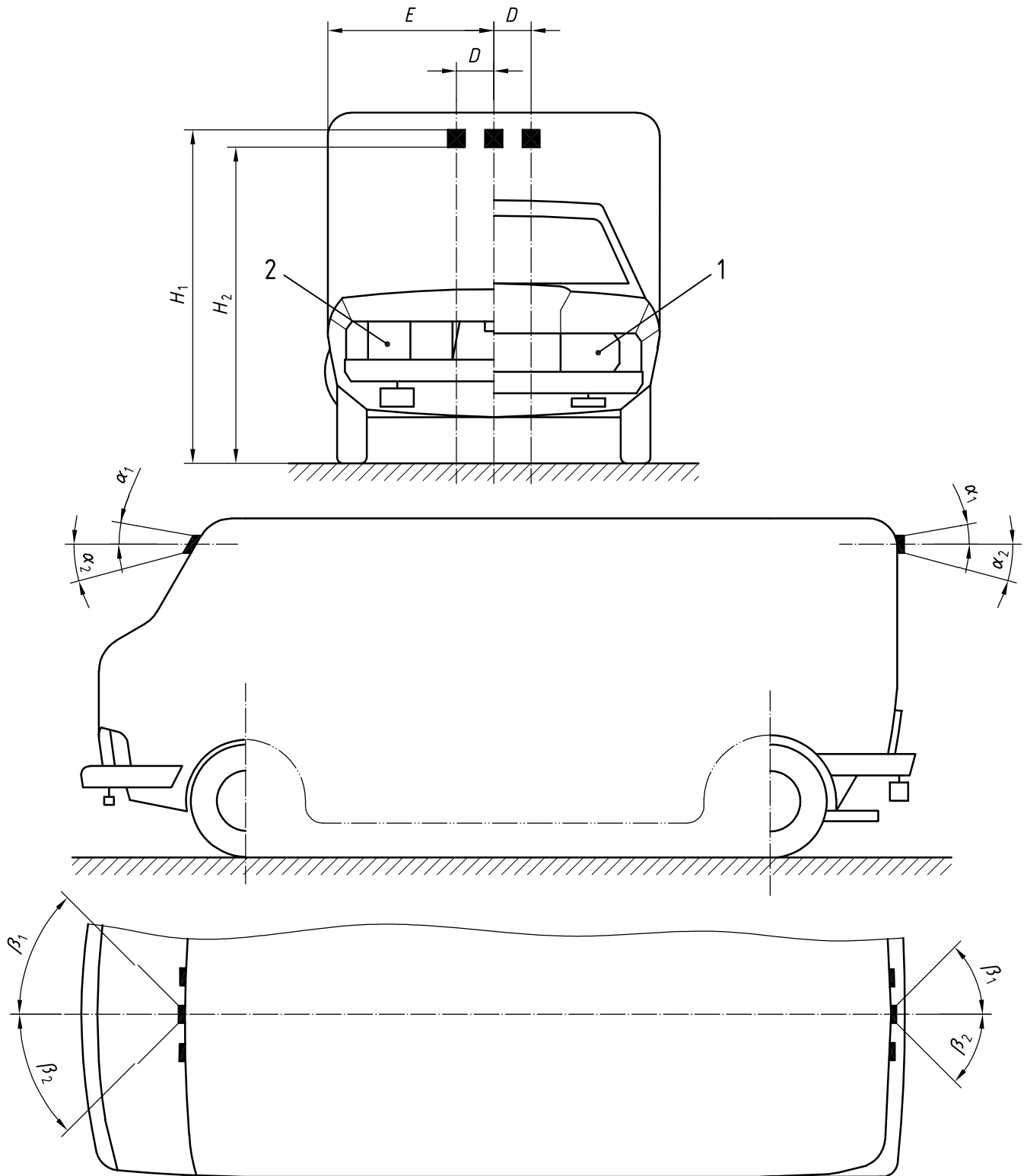

Key

- 1 Front
- 2 Rear

Figure E.22 — Front and rear identification lamps

E.23 Front retro-reflector (non-triangular)

E.23.1 Layout

See Figure E.23.

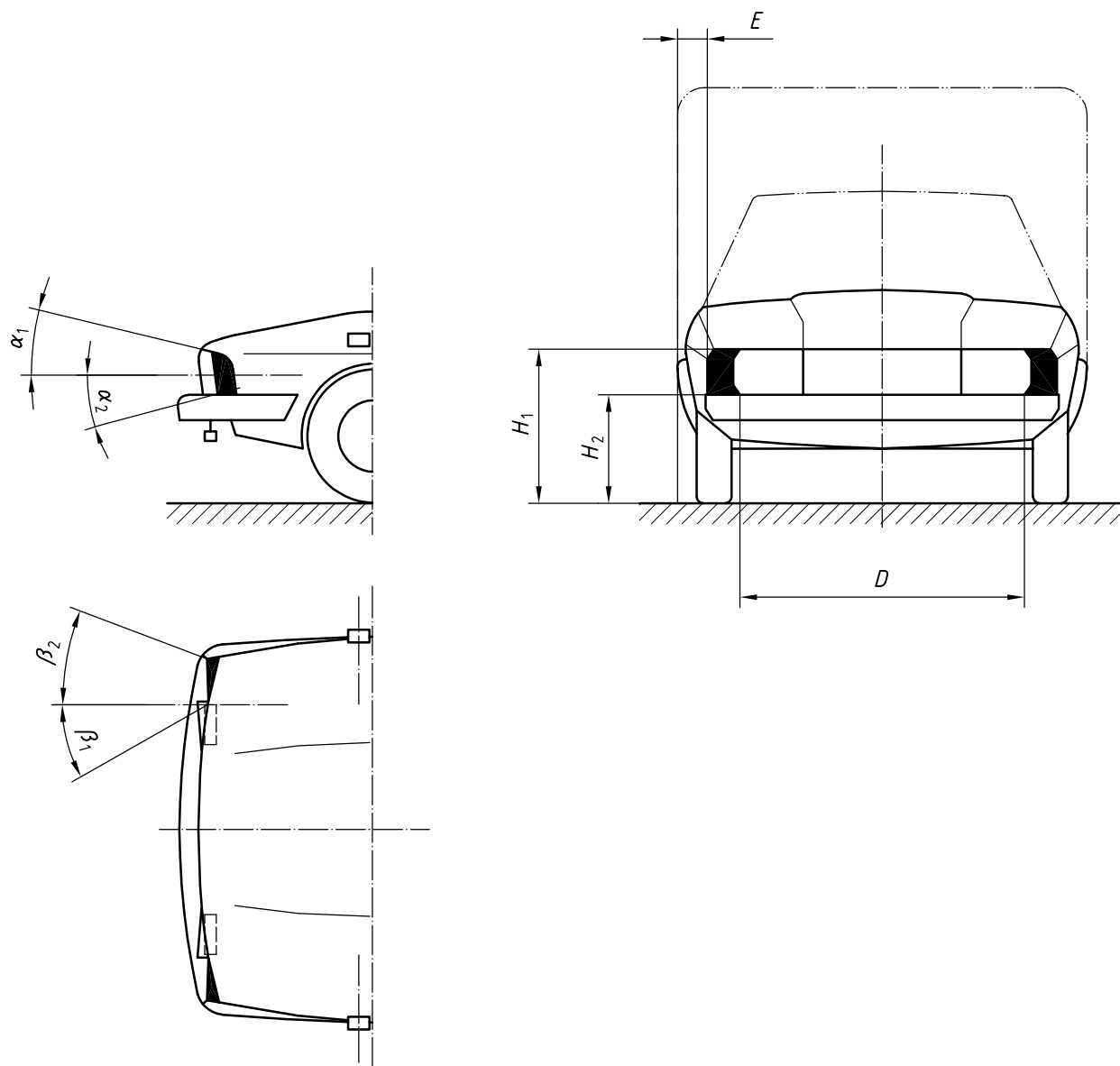

Figure E.23 — Front, non-triangular, retro-reflector

E.23.2 Application

For motor vehicles and trailers.

E.23.3 Number

Two — however, additional retro-reflecting devices and materials are permitted, provided they do not impair the effectiveness of other lighting and light signalling devices.

E.23.4 Dimensions (in millimetres)

$$H_1 \leq 900 \text{ (or 1 500 if the vehicle structure prevents compliance with 900)}^3)$$

$$H_2 \geq 250$$

$$E \leq 400 \text{ for motor vehicles; } \leq 150 \text{ for trailers}^3)$$

E.23.5 Minimum angles of geometric visibility

$$\alpha_1: 15^\circ$$

$$\alpha_2: 15^\circ \text{ (5}^\circ \text{ if } H_2 < 750 \text{ mm)}$$

$$\beta_1: 30^\circ$$

For trailers, this may be reduced to 10°. If, owing to the construction of the trailer, the value cannot be met by the minimum retro-reflector, then an additional retro-reflector shall be fitted, without the width limitation, which shall, in conjunction with the minimum retro-reflector, give the necessary visibility angle.

$$\beta_2: 30^\circ$$

E.23.6 Configuration

The illuminating surface of the front retro-reflector may have parts in common with any other lamp.

3) Both values apply to minimum retro-reflector only.

E.24 Rear retro-reflector (triangular)

E.24.1 Layout

See Figure E.24.

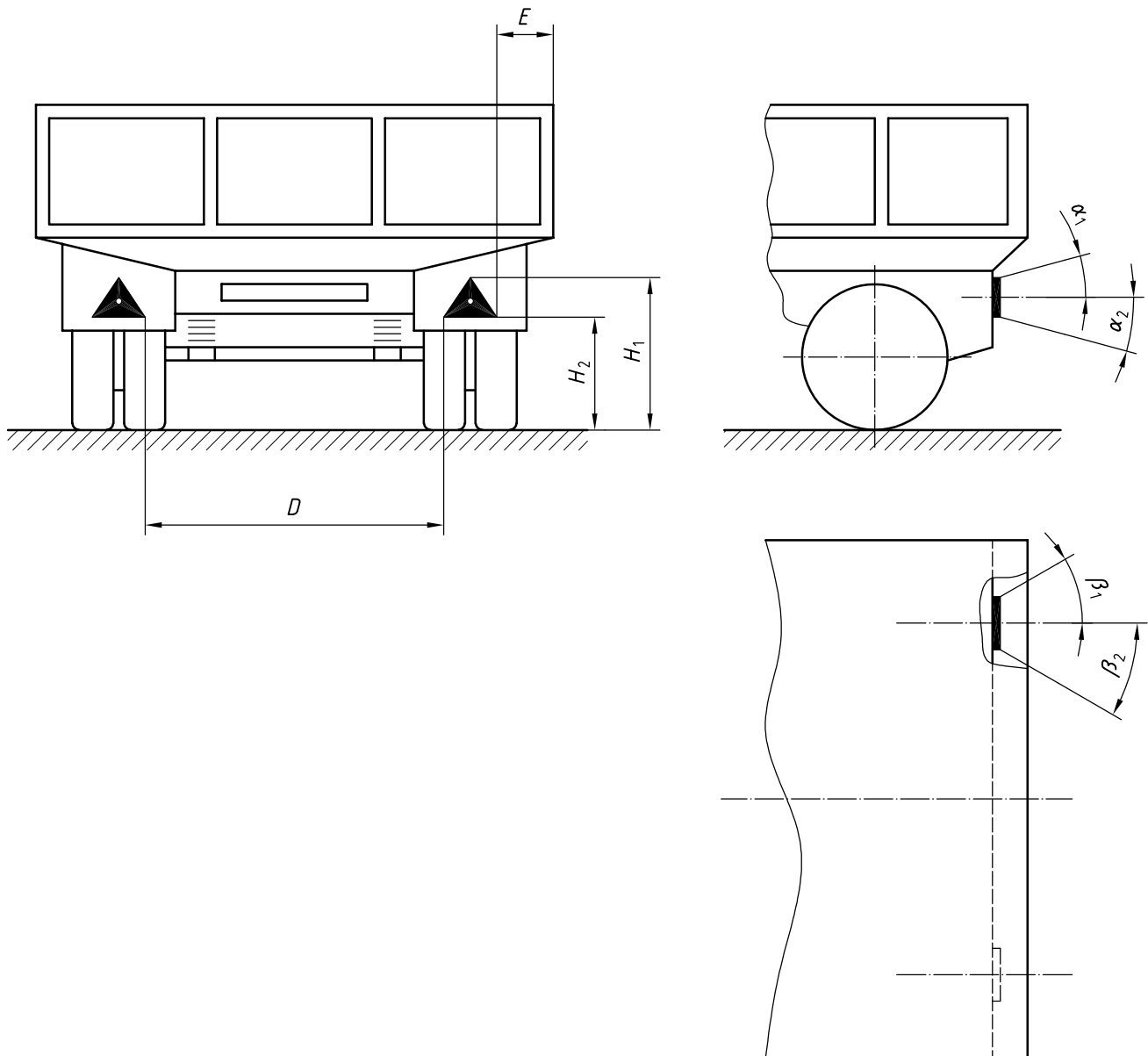

Figure E.24 — Rear triangular retro-reflector

E.24.2 Application

For trailers only.

E.24.3 Number

Two — additional retro-reflecting devices and materials may be used, provided they do not impair the effectiveness of other lighting and light signalling devices.

E.24.4 Dimensions (in millimetres)

$$H_1 \leq 900 \text{ (or 1 500 if the vehicle structure prevents compliance with 900)}$$

$$H_2 \geq 250$$

$$D \geq 600$$

$$E \leq 400$$

E.24.5 Minimum angles of geometric visibility

$$\alpha_1: 15^\circ$$

$$\alpha_2: 15^\circ \text{ (5}^\circ \text{ if } H_2 < 750 \text{ mm)}$$

$$\beta_1: 30^\circ$$

$$\beta_2: 30^\circ$$

E.24.6 Configuration

A rear retro-reflector shall not be grouped with a lamp.

E.24.7 Alignment

To the rear, the apex of the triangle shall be uppermost.

E.25 Daytime running lamp

E.25.1 Layout

See Figure E.25.

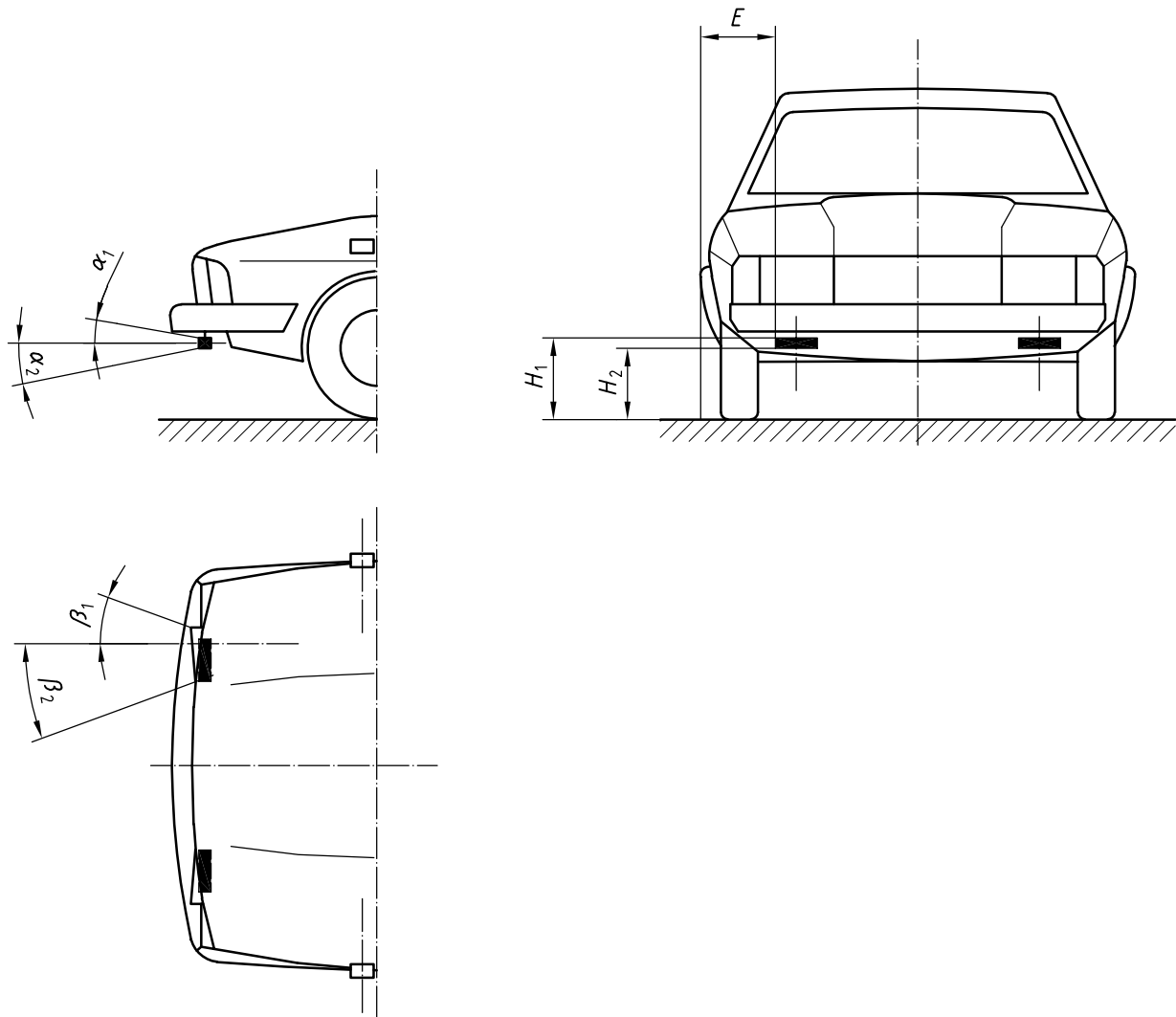

Figure E.25 — Daytime running lamp

E.25.2 Application

For motor vehicles only.

E.25.3 Number

Two.

E.25.4 Dimensions (in millimetres)

$$H_1 \leq 1\,500$$

$$H_2 \geq 250$$

$$E \leq 400$$

E.25.5 Minimum angles of geometric visibility

$$\alpha_1: 10^\circ$$

$$\alpha_2: 10^\circ$$

$$\beta_1: 20^\circ$$

$$\beta_2: 20^\circ$$

E.25.6 Electrical connections

The daytime running lamp shall switch off automatically when the headlamps are switched on, except when the headlamps are used to give intermittent luminous warnings at short intervals.

E.26 Cornering lamp

E.26.1 Layout

See Figure E.26.

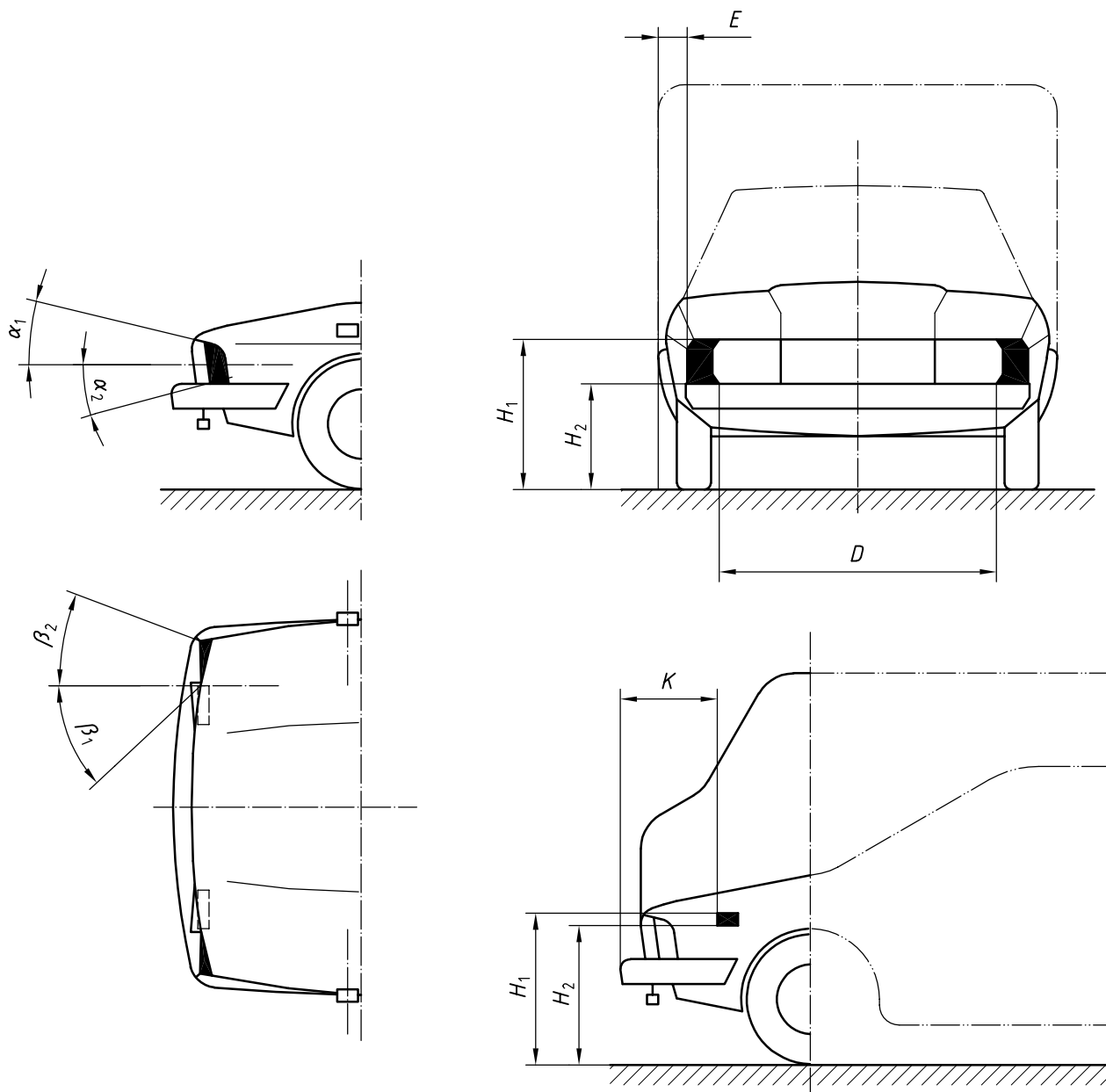

Figure E.26 — Cornering lamp

E.26.2 Application

For motor vehicles only.

E.26.3 Number

Two.

E.26.4 Dimensions (in millimetres)

H_1 : no point of the illuminating surface shall be higher than the highest point of the illuminating surface of the dipped-beam headlamp.

H_2 : unspecified

D : unspecified

E : unspecified

K : this shall be as close to the front as practicable.

E.26.5 Minimum angles of geometric visibility

α_1 : unspecified

α_2 : unspecified

β_1 : unspecified

β_2 : unspecified

E.26.6 Electrical connections

The cornering lamp shall be lighted only when the corresponding direction indicator is activated.

E.26.7 Special requirements

A lamp on the left side of the vehicle shall not illuminate on the right side of the reference centre.

A lamp on the right side of the vehicle shall not illuminate on the left side of the reference centre.

Bibliography

- [1] CIE⁴⁾ S004, *Colours of light signals*
- [2] ECE Regulation No. 48 — *Uniform provisions concerning the approval of vehicles with regard to the installation of lighting and light signalling devices*
- [3] 76/756/EEC Directive of July 27, 1976 on the approximation of the laws of the member states relating to the installation of lighting and light signalling devices
- [4] US Federal Motor Vehicle Safety Standard (FMVSS) No. 108, *Lamps, reflective devices and associated equipment*
- [5] Canadian Motor Vehicle Safety Standard (CMVSS) No. 108, *Lighting equipment*

4) International Commission on Illumination.

