

INTERNATIONAL STANDARD

ISO
299

Second edition
1987-04-01



INTERNATIONAL ORGANIZATION FOR STANDARDIZATION
ORGANISATION INTERNATIONALE DE NORMALISATION
МЕЖДУНАРОДНАЯ ОРГАНИЗАЦИЯ ПО СТАНДАРТИЗАЦИИ

Machine tool tables — T-slots and corresponding bolts

Tables de machines-outils — Rainures à T et boulons correspondants

Reference number
ISO 299 : 1987 (E)

Foreword

ISO (the International Organization for Standardization) is a worldwide federation of national standards bodies (ISO member bodies). The work of preparing International Standards is normally carried out through ISO technical committees. Each member body interested in a subject for which a technical committee has been established has the right to be represented on that committee. International organizations, governmental and non-governmental, in liaison with ISO, also take part in the work.

Draft International Standards adopted by the technical committees are circulated to the member bodies for approval before their acceptance as International Standards by the ISO Council. They are approved in accordance with ISO procedures requiring at least 75 % approval by the member bodies voting.

International Standard ISO 299 was prepared by Technical Committee ISO/TC 39, *Machine tools*.

This second edition cancels and replaces the first edition (ISO 299 : 1973), of which the dimensions in inches have been deleted and to which clause 5 has been added.

Users should note that all International Standards undergo revision from time to time and that any reference made herein to any other International Standard implies its latest edition, unless otherwise stated.

Machine tool tables — T-slots and corresponding bolts

1 Scope and field of application

This International Standard specifies, in millimetres, the dimensions and spacing of T-slots for machine tool tables.

It also specifies the metric dimensions of bolts to be used in these slots.

2 Dimensions of slots and bolts

The dimensions of T-slots and of the corresponding bolts are specified in table 1. The corresponding dimensions in inches,

except for the dimensions of bolts below 6 mm and above 36 mm for which there are no corresponding values, will form the subject of an addendum. The corresponding values will ensure practical interchangeability between machines made in either of the two measurement systems, as well as interchangeability with existing machines in many cases.

For reference or fixing slots, there is no interchangeability from one measurement system to the other, since the nominal dimension, A , will not be identical in this International Standard and its addendum.

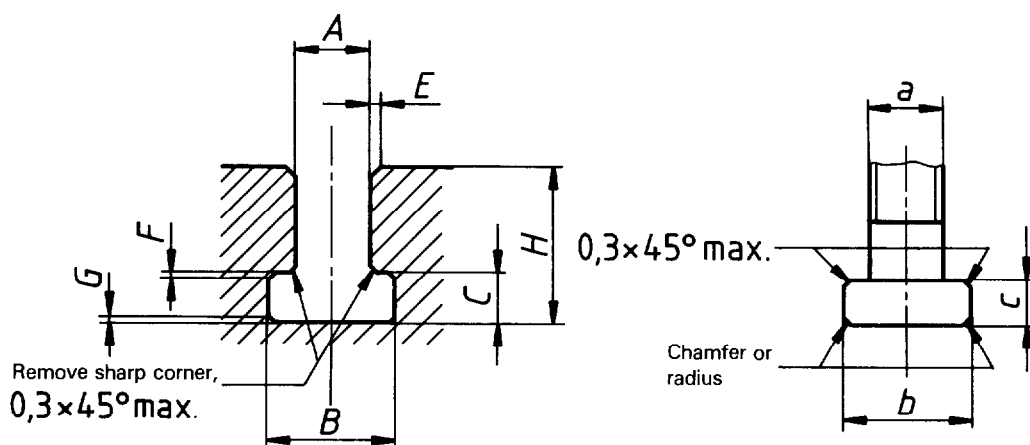

E, F and G : 45°-chamfer height or radius

Table 1

Slot										Bolt		
A	B		C		H		E	F	G	a	b	c
	min.	max.	min.	max.	min.	max.						
5	10	11	3,5	4,5	8	10	1	0,6	1	M4	9	3
6	11	12,5	5	6	11	13	1	0,6	1	M5	10	4
8	14,5	16	7	8	15	18	1	0,6	1	M6	13	6
10	16	18	7	8	17	21	1	0,6	1	M8	15	6
12	19	21	8	9	20	25	1	0,6	1	M10	18	7
14	23	25	9	11	23	28	1,6	0,6	1,6	M12	22	8
18	30	32	12	14	30	36	1,6	1	1,6	M16	28	10
22	37	40	16	18	38	45	1,6	1	2,5	M20	34	14
28	46	50	20	22	48	56	1,6	1	2,5	M24	43	18
36	56	60	25	28	61	71	2,5	1	2,5	M30	53	23
42	68	72	32	35	74	85	2,5	1,6	4	M36	64	28
48	80	85	36	40	84	95	2,5	2	6	M42	75	32
54	90	95	40	44	94	106	2,5	2	6	M48	85	36

Slots : Tolerances on A : H12 for fixing slots,
H8 for reference slots.

Bolt : Tolerances on a, b, c : usual tolerances for bolts and nuts.

NOTE — Although assembly by bolts is the only one shown, any other device complying with the same interchangeability conditions may be regarded as being in agreement with this International Standard.

3 Spacing of slots

For each dimension A of standardized T-slots, three or four values of pitch P are given in table 2, from which the manufacturer is advised, unless there is a justifiable reason to do otherwise, to choose the one best fitted to the dimensions of a given

table or plate and to the number of slots required for its use, additionally taking into account the advantage of providing, whenever possible, symmetrically arranged slots about a median slot which is usually machined as a reference slot. When there is an even number of slots, the reference slot shall be clearly identified on the machine table itself.

Table 2

Slot width, A	Pitch, $P^{1), 2)}$
5	20 – 25 – 32
6	25 – 32 – 40
8	32 – 40 – 50
10	40 – 50 – 63
12	(40) – 50 – 63 – 80
14	(50) – 63 – 80 – 100
18	(63) – 80 – 100 – 125
22	(80) – 100 – 125 – 160
28	100 – 125 – 160 – 200
36	125 – 160 – 200 – 250
42	160 – 200 – 250 – 320
48	200 – 250 – 320 – 400
54	250 – 320 – 400 – 500

1) Where values of P greater or less than those given in table 2 are absolutely necessary, they shall be chosen from the values of the R10 series of preferred numbers; where intermediate values are required, they shall be chosen from the values of the R20 series.

2) Where possible the pitches shown in parentheses should be avoided owing to the smaller thickness of material between the T-slots ($P_{\min} - B_{\max}$).

4 Tolerances on pitches of T-slots

Table 3

Pitch, P	Tolerance
20 and 25	$\pm 0,2$
32 to 100	$\pm 0,3$
125 to 250	$\pm 0,5$
320 to 500	$\pm 0,8$

NOTE – The tolerance on the pitch of any T-slot is non-cumulative.

5 Designation

The T-slots and the corresponding bolts shall be designated by the nominal dimension of the bolt thread, e.g. M10.

ISO 299 : 1987 (E)

UDC 621.9.06-229.311.

Descriptors : machine tools, machine tables, work-holding fixed tables, T slots, bolts, dimensions.

Price based on 3 pages
