**Conveyor belts — Electrical conductivity —
Specification and test method**

*Courroies transporteuses — Conductibilité électrique — Spécification et
méthode d'essai*



Reference number
ISO 284:2012(E)

© ISO 2012

.....



COPYRIGHT PROTECTED DOCUMENT

© ISO 2012

All rights reserved. Unless otherwise specified, no part of this publication may be reproduced or utilized in any form or by any means, electronic or mechanical, including photocopying and microfilm, without permission in writing from either ISO at the address below or ISO's member body in the country of the requester.

ISO copyright office
Case postale 56 • CH-1211 Geneva 20
Tel. + 41 22 749 01 11
Fax + 41 22 749 09 47
E-mail copyright@iso.org
Web www.iso.org

Published in Switzerland

Contents

Page

Foreword	iv
1 Scope	1
2 Normative references	1
3 Specification	1
4 Test method	1
4.1 Principle	1
4.2 Materials and apparatus	1
4.3 Test pieces	2
4.4 Atmosphere for conditioning and testing	3
4.5 Procedure	3
4.6 Expression of results	4
4.7 Test report	4
Annex A (informative) Variation of electrical resistance with temperature and humidity	5
Bibliography	6

Foreword

ISO (the International Organization for Standardization) is a worldwide federation of national standards bodies (ISO member bodies). The work of preparing International Standards is normally carried out through ISO technical committees. Each member body interested in a subject for which a technical committee has been established has the right to be represented on that committee. International organizations, governmental and non-governmental, in liaison with ISO, also take part in the work. ISO collaborates closely with the International Electrotechnical Commission (IEC) on all matters of electrotechnical standardization.

International Standards are drafted in accordance with the rules given in the ISO/IEC Directives, Part 2.

The main task of technical committees is to prepare International Standards. Draft International Standards adopted by the technical committees are circulated to the member bodies for voting. Publication as an International Standard requires approval by at least 75 % of the member bodies casting a vote.

Attention is drawn to the possibility that some of the elements of this document may be the subject of patent rights. ISO shall not be held responsible for identifying any or all such patent rights.

ISO 284 was prepared by Technical Committee ISO/TC 41, *Pulleys and belts (including veebelts)*, Subcommittee SC 3, *Conveyor belts*.

This fourth edition cancels and replaces the third edition (ISO 284:2003), of which it constitutes a minor revision.

Conveyor belts — Electrical conductivity — Specification and test method

1 Scope

This International Standard specifies the maximum electrical resistance of a conveyor belt and the corresponding test method.

The test is intended to ensure that the belt is sufficiently conductive to avoid the accumulation of electrical static charge which can be developed during service use.

This International Standard is not suitable or applicable to light conveyor belts as described in ISO 21183-1^[1], the static electrical properties of which are measured by ISO 21178^[2].

2 Normative references

The following documents, in whole or in part, are normatively referenced in this document and are indispensable for its application. For dated references, only the edition cited applies. For undated references, the latest edition of the referenced document (including any amendments) applies.

ISO 18573, *Conveyor belts — Test atmospheres and conditioning periods*

3 Specification

The electrical resistance of the conveyor belt when tested in accordance with the method described in Clause 4 shall not exceed $3 \times 10^8 \Omega$ (300 M Ω). Lower values may be specified for special applications.

4 Test method

4.1 Principle

An electric current of specified voltage is passed via electrodes through a suitably prepared test piece taken from the belt.

4.2 Materials and apparatus

4.2.1 Sheet of insulating material, a little larger than the test piece.

4.2.2 Two cylindrical and coaxial brass electrodes, the base of one being circular and the other annular.

The dimensions and masses are given in Figure 1. The bases of these electrodes shall be machined flat and polished. A flexible insulated wire shall be connected to each electrode.

4.2.3 Ohmmeter (resistance-measuring instrument), with a range up to $10^{10} \Omega$ and accurate to $\pm 5\%$.

4.2.4 Source of direct current, adjustable to 1 000 V, and not permitting a current greater than 10 mA or causing an energy dissipation of more than 1 W in the test piece.

The source of current may be either an accumulator or a rectified, stabilized AC-power supply.

4.2.5 Contact agent (to ensure good contact between electrodes and test piece), having an electrical surface resistivity no higher than $10^4 \Omega$.

A jelly of suitable composition is given in Table 1.

Table 1 — Suitable composition of contact agent

Component	Proportion mass fraction
Anhydrous polyethylene glycol (molecular mass: 600)	800 mg/g
Water	200 mg/g
Potassium chloride	10 mg/g
Soft soap (pharmaceutical quality)	1 mg/g

Dimensions in millimetres

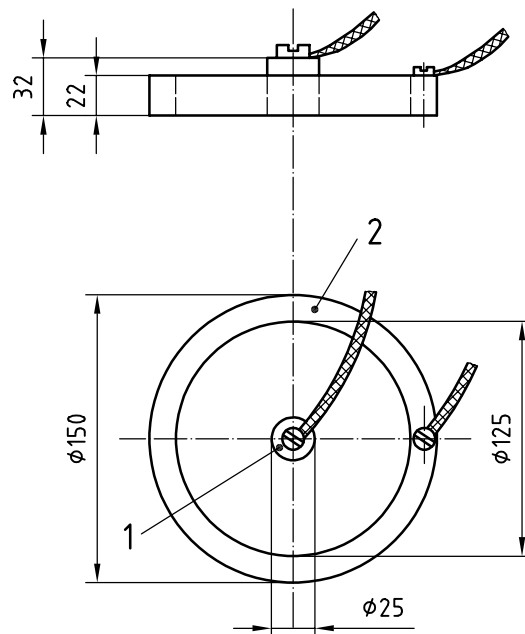

Key

- 1 electrode of minimum mass of 115 g
- 2 electrode of minimum mass of 900 g

Figure 1 — Electrodes

4.3 Test pieces

4.3.1 Dimensions

The test piece shall be square and shall be cut from the full thickness of the belt. The length of a side shall be 300 mm minimum.

4.3.2 Number

One test piece shall be taken. If the specification requires that two or more test pieces are to be taken but does not specify how they shall be selected, reference may be made to ISO 282^[3].

4.3.3 Cleaning of test surfaces

If suitable, clean both surfaces of the test piece by rubbing with Fuller's earth, (i.e. hydrated magnesium-aluminium silicate), for example, using a clean cloth. After cleaning away all traces of the powder, wipe the surface with a clean cloth moistened with distilled water, then dry with a clean cloth.

4.4 Atmosphere for conditioning and testing

Before testing, expose the test piece for at least 2 h to one of the standard laboratory atmospheres specified in ISO 18573. Conduct the test in this atmosphere (see Annex A). An atmosphere of $23\text{ °C} \pm 2\text{ °C}$ and $50\% \pm 5\%$ relative humidity is preferred.

4.5 Procedure

4.5.1 Check test room atmosphere.

4.5.2 Paint on one of the surfaces of the test piece the contact agent (4.2.5) in the two areas illustrated in Figure 2. Great care shall be taken to ensure the accuracy of the dimensions of the areas, but the symmetry of the centre is not critical. If the test piece surface is flat, this jelly may be painted on the bottom surface of the cleaned electrodes. In the case of textured surfaces, the two areas shown in Figure 2 shall be painted on the test piece. The test shall be carried out immediately after painting.

NOTE In the case of covers with surface undulations, contact between the electrodes and the test piece can be improved by thin sheets of metal foil of the same dimensions as the brass electrodes, placed on the liquid contact agent and made to follow the form of the surface by rubbing lightly with the finger. The brass electrodes are then placed on the foil.

4.5.3 Place the test piece on the sheet of insulating material, with the test surface upwards.

4.5.4 Clean the lower faces of the brass electrodes and place them on the liquid contact agent pattern on the test piece.

4.5.5 Take care not to breathe on the test surface, as any condensation of moisture may falsify the result.

4.5.6 Connect the outer electrode to the earth or low-voltage terminal of the measuring instrument.

4.5.7 Connect the inner electrode to the high-voltage terminal of the measuring instrument.

4.5.8 Measure the resistance after applying the voltage for at least 1 min.

4.5.9 Repeat the test on the other surface of the test piece.

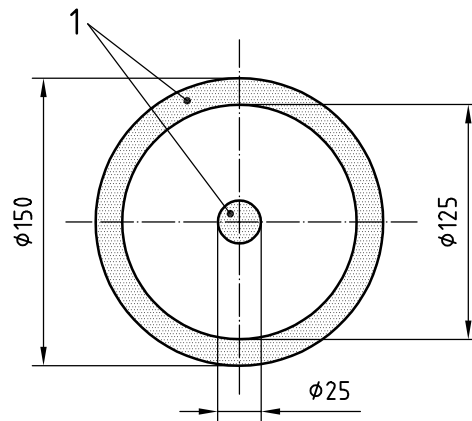
**Key**

- 1 contact agent (4.2.5)

Figure 2 — Design to be painted on the test piece

4.6 Expression of results

For each surface of the belt subjected to test, record the electrical resistance, in ohms.

4.7 Test report

The test report shall include the following information:

- complete designation of the conveyor belt material and the manufacturing date;
- reference to this International Standard, i.e. ISO 284:2012;
- test room temperature and relative humidity;
- conditioning period;
- contact agent applied;
- voltage applied to the electrodes;
- results of the tests;
- date of test;
- any deviations from the standard test.

Annex A (informative)

Variation of electrical resistance with temperature and humidity

A.1 General

The materials used for the covers of conveyor belts are, in terms of electrical resistance, sensitive to their temperature-history and their strain-history. This phenomenon arises because of the structural configuration of the conductive particles (e.g. carbon) in the polymer and the degree of their orientation, which can change, between the manufacturing stage and installation due to the strain-history of the belt.

The antistatic properties of the covers of conveyor belts are also influenced by their electrostatic charging characteristics, which are related to their relative permittivity, a full discussion of which can be found in IEC 60250^[4].

A.2 Conformity

The surface electrical resistance of a conveyor belt cover as measured by this method may vary if the temperature in the test laboratory varies during the test and will fall dramatically if the relative humidity rises above 50 %. If a test result does not prove conformity with the requirements of this specification, it is advisable for the test to be repeated at the higher limit of temperature and humidity required by the product specification.

Bibliography

- [1] ISO 21183-1, *Light conveyor belts — Part 1: Principal characteristics and applications*
- [2] ISO 21178, *Light conveyor belts — Determination of electrical resistances*
- [3] ISO 282, *Conveyor belts — Sampling*
- [4] IEC 60250, *Recommended methods for the determination of the permittivity and dielectric dissipation factor of electrical insulating materials at power, audio and radio frequencies including metre wavelengths*

ICS 53.040.10

Price based on 6 pages