

---

---

**Test code for machine tools —**

Part 10:

**Determination of the measuring  
performance of probing systems of  
numerically controlled machine tools**

*Code d'essai des machines-outils —*

*Partie 10: Détermination des performances de mesure des systèmes de  
palpage des machines-outils à commande numérique*





**COPYRIGHT PROTECTED DOCUMENT**

© ISO 2016, Published in Switzerland

All rights reserved. Unless otherwise specified, no part of this publication may be reproduced or utilized otherwise in any form or by any means, electronic or mechanical, including photocopying, or posting on the internet or an intranet, without prior written permission. Permission can be requested from either ISO at the address below or ISO's member body in the country of the requester.

ISO copyright office  
Ch. de Blandonnet 8 • CP 401  
CH-1214 Vernier, Geneva, Switzerland  
Tel. +41 22 749 01 11  
Fax +41 22 749 09 47  
copyright@iso.org  
www.iso.org

# Contents

	Page
Foreword .....	v
Introduction .....	vi
<b>1 Scope</b> .....	<b>1</b>
<b>2 Normative references</b> .....	<b>1</b>
<b>3 Terms and definitions</b> .....	<b>2</b>
3.1 General terms .....	2
3.2 Terms relating to the probing system .....	2
3.3 Terms relating to probing .....	5
3.4 Terms relating to scanning probes (See <a href="#">Annex B</a> ) .....	7
<b>4 Preliminary remarks</b> .....	<b>8</b>
4.1 Influences on the measurement performance of the probing system .....	8
4.2 Measurement units .....	9
4.3 Reference to ISO 230-1 .....	9
4.4 Recommended instrumentation and test equipment .....	9
4.5 Machine conditions prior to testing .....	9
4.6 Testing sequence .....	9
4.7 Tests to be performed .....	9
4.8 Sources of test uncertainty .....	10
4.9 Reporting of test results .....	10
<b>5 Thermal influences</b> .....	<b>11</b>
5.1 General .....	11
5.2 Environmental temperature variation error (ETVE) test .....	11
5.3 Other thermal distortion tests .....	11
<b>6 Probing of workpiece</b> .....	<b>12</b>
6.1 General .....	12
6.2 Probing repeatability .....	12
6.2.1 General .....	12
6.2.2 Probing repeatability test for single-point surface measurement, $R_{SPT,X}$ , $R_{SPT,Y}$ and $R_{SPT,Z}$ ( $R_{Single\_Point,X,Y,Z}$ ) .....	13
6.2.3 Probing repeatability test for circle centre location, $R_{CIR,X}$ and $R_{CIR,Y}$ ( $R_{CIRcle,X,Y}$ ) .....	13
6.2.4 Probing repeatability test for sphere centre location, $R_{SPH,X}$ , $R_{SPH,Y}$ and $R_{SPH,Z}$ ( $R_{SPHere,X,Y,Z}$ ) .....	14
6.3 Stylus tip offset test, $A$ .....	14
6.3.1 General .....	14
6.3.2 Test setup and procedure .....	14
6.3.3 Analysis of results .....	14
6.4 Probing-tool location repeatability test, $R_{PTL,X}$ , $R_{PTL,Y}$ and $R_{PTL,Z}$ ( $R_{Probing-Tool\_Location,X,Y,Z}$ ) .....	15
6.4.1 General .....	15
6.4.2 Test setup and procedure .....	15
6.4.3 Analysis of results .....	15
6.5 2D probing error test, $P_{FTU,2D}$ ( $P_{Form\_Tactile\_Unique,2D}$ ) .....	15
6.5.1 General .....	15
6.5.2 Test setup and procedure .....	16
6.5.3 Analysis of results .....	16
6.6 3D probing error test, $P_{FTU,3D}$ ( $P_{Form\_Tactile\_Unique,3D}$ ) .....	17
6.6.1 General .....	17
6.6.2 Test setup and procedure .....	17
6.6.3 Analysis of test results .....	18
6.7 Workpiece position and orientation tests, $E_{PLA,Z}$ , $E_{LIN,Y}$ , $E_{COR,X}$ , $E_{COR,Y}$ and $E_{COR,Z}$ ( $E_{PLAne,Z}$ ), ( $E_{LINE,Y}$ ), ( $E_{CORner\ coordinates,X,Y,Z}$ ) .....	18

6.7.1	General	18
6.7.2	Test setup	21
6.7.3	Test procedure	22
6.7.4	Analysis of results	23
6.7.5	Alternative workpiece position and orientation test	23
6.8	Combined workpiece machining and location test, $E_{CML,X}$ , $E_{CML,Y}$ , $E_{CML,Z}$ , $R_{CML,X}$ , $R_{CML,Y}$ and $R_{CML,Z}$ ( $E$ Combined Machining and Location, X,Y,Z), ( $R$ Combined Machining and Location, X,Y,Z)	25
6.8.1	General	25
6.8.2	Test setup and procedure	25
6.8.3	Analysis of results	26
6.9	Time delay variation tests	26
6.9.1	General	26
6.9.2	Time delay variation test for individual axes, $E_{SPT,TD,X}$ , $E_{SPT,TD,Y}$ , $E_{SPT,TD,Z}$ ( $E_{Single-Point}$ , Time Delay variation, X,Y,Z)	27
6.9.3	Time delay variation test for XY plane circle measurement, $E_{CIR,TD,X}$ , $E_{CIR,TD,Y}$ , $E_{CIR,TD,D}$ and $E_{CIR,TD,F}$ ( $E_{CIRcle}$ , Time Delay variation, X,Y), ( $E_{CIRcle}$ , Time Delay variation, Diameter) and ( $E_{CIRcle}$ , Time Delay variation, Form)	28
6.9.4	Time delay variation test for sphere measurement, $E_{SPH,TD,X}$ , $E_{SPH,TD,Y}$ , $E_{SPH,TD,Z}$ , $E_{SPH,TD,D}$ and $E_{SPH,TD,F}$ ( $E_{SPHere}$ , Time Delay variation, X,Y,Z), ( $E_{SPHere}$ , Time Delay variation, Diameter) and ( $E_{SPHere}$ , Time Delay variation, Form)	29
6.10	Feature size measurement performance tests	30
6.10.1	General	30
6.10.2	Web size measurement performance test, $E_{WEB,X}$ , $E_{WEB,Y}$ , $R_{WEB,X}$ and $R_{WEB,Y}$	31
6.10.3	Circle diameter measurement performance test, $E_{CIR,D}$ and $R_{CIR,D}$ ( $E_{CIRcle}$ , Diameter) and ( $R_{CIRcle}$ , Diameter)	31
6.10.4	Sphere diameter measurement performance test, $E_{SPH,D}$ and $R_{SPH,D}$ ( $E_{SPHere}$ , Diameter) and ( $R_{SPHere}$ , Diameter)	32
<b>7</b>	<b>Probing of tools</b>	<b>32</b>
7.1	General	32
7.2	Tool-setting system qualification	33
7.3	Tool-setting repeatability	33
7.3.1	General	33
7.3.2	Tool length-setting repeatability with a non-rotating tool, $R_{SET,L,N}$ ( $R_{SETting,Length,Non-rotating}$ )	34
7.3.3	Tool length-setting repeatability of a rotating tool, $R_{SET,L,R}$ ( $R_{SETting,Length,Rotating}$ )	34
7.3.4	Tool diameter setting repeatability, $R_{SET,D,R}$ ( $R_{SETting,Diameter,Rotating}$ )	35
<b>Annex A (informative) Alphabetical cross-references and short description of symbols</b>		<b>37</b>
<b>Annex B (informative) Measuring performance with scanning probes</b>		<b>39</b>
<b>Bibliography</b>		<b>45</b>

## Foreword

ISO (the International Organization for Standardization) is a worldwide federation of national standards bodies (ISO member bodies). The work of preparing International Standards is normally carried out through ISO technical committees. Each member body interested in a subject for which a technical committee has been established has the right to be represented on that committee. International organizations, governmental and non-governmental, in liaison with ISO, also take part in the work. ISO collaborates closely with the International Electrotechnical Commission (IEC) on all matters of electrotechnical standardization.

The procedures used to develop this document and those intended for its further maintenance are described in the ISO/IEC Directives, Part 1. In particular the different approval criteria needed for the different types of ISO documents should be noted. This document was drafted in accordance with the editorial rules of the ISO/IEC Directives, Part 2 (see [www.iso.org/directives](http://www.iso.org/directives)).

Attention is drawn to the possibility that some of the elements of this document may be the subject of patent rights. ISO shall not be held responsible for identifying any or all such patent rights. Details of any patent rights identified during the development of the document will be in the Introduction and/or on the ISO list of patent declarations received (see [www.iso.org/patents](http://www.iso.org/patents)).

Any trade name used in this document is information given for the convenience of users and does not constitute an endorsement.

For an explanation on the meaning of ISO specific terms and expressions related to conformity assessment, as well as information about ISO's adherence to the WTO principles in the Technical Barriers to Trade (TBT) see the following URL: [Foreword - Supplementary information](#)

The committee responsible for this document is ISO/TC 39, *Machine tools*, Subcommittee SC 2, *Test conditions for metal cutting machine tools*.

This second edition cancels and replaces the first edition (ISO 230-10:2011), of which it constitutes a minor revision. It also incorporates the amendment ISO 230-10:2011/Amd 1:2014. In [Table B.1](#) an entry with the value of "R x 0,050" has been replaced with "R x 0,500".

ISO 230 consists of the following parts, under the general title *Test code for machine tools*:

- *Part 1: Geometric accuracy of machines operating under no-load or quasi-static conditions*
- *Part 2: Determination of accuracy and repeatability of positioning numerically controlled axes*
- *Part 3: Determination of thermal effects*
- *Part 4: Circular tests for numerically controlled machine tools*
- *Part 5: Determination of the noise emission*
- *Part 6: Determination of positioning accuracy on body and face diagonals (Diagonal displacement tests)*
- *Part 7: Geometric accuracy of axes of rotation*
- *Part 8: Vibrations [Technical Report]*
- *Part 9: Estimation of measurement uncertainty for machine tool tests according to series ISO 230, basic equations [Technical Report]*
- *Part 10: Determination of the measuring performance of probing systems of numerically controlled machine tools*

The following part is under preparation:

- *Part 11: Measuring instruments and their application to machine tool geometry tests [Technical Report]*

## Introduction

The purpose of ISO 230 (all parts) is to standardize methods of testing the accuracy of machine tools, excluding portable power tools.

This part of ISO 230 concerns test procedures to evaluate the measuring performance of contacting probing systems (used in a discrete-point probing mode) integrated with a numerically controlled machine tool. The test procedures are not intended to distinguish between the various causes of errors. They intend to demonstrate the combined influence of the environment, machine tool, probing system and probing software on the measuring performance.

The results of these tests do not reflect on the performance of the machine tool in a metal cutting mode. When the tests are required for acceptance purposes, it is up to the user to choose, in agreement with the manufacturer/supplier, those tests relating to the properties of the components of the machine probing system, which are of interest.

The results of these tests do not reflect on the performance of the machine tool used as a coordinate measuring machine (CMM). Such performance involves traceability issues and it is intended that they be evaluated according to ISO 10360-2 and ISO 10360-5.

An alphabetical list and short description of the symbols used in this part of ISO 230 is given in [Annex A](#).

Test procedures to measure performance with scanning probes are given in [Annex B](#).

# Test code for machine tools —

## Part 10:

# Determination of the measuring performance of probing systems of numerically controlled machine tools

## 1 Scope

This part of ISO 230 specifies test procedures to evaluate the measuring performance of contacting probing systems (used in a discrete-point probing mode) integrated with a numerically controlled machine tool.

It does not include other types of probing systems, such as those used in scanning mode or non-contacting probing systems. The evaluation of the performance of the machine tool, used as a coordinate measuring machine (CMM), is outside the scope of this part of ISO 230. Such performance evaluation involves traceability issues, is strongly influenced by machine tool geometric accuracy and can, in addition to the machine tool probing system tests specified in this part of ISO 230, be evaluated according to ISO 10360-2 and ISO 10360-5.

Numerically controlled machine tools can apply contacting probing systems in machining process applications, such as

- identification that the correct workpiece has been loaded before machining,
- location and/or alignment of the workpiece,
- measurement of the workpiece after machining, but while still on the machine,
- measurement of the position and orientation of the machine tool rotary axes,
- measurement and setting of the cutting tool (radius, length and offset of the tool), and
- detection of tool breakage.

NOTE 1 This part of ISO 230 focuses on machining centres, but it is intended that other types of machines, for instance turning and grinding centres, be included in a future revision of this part of ISO 230.

NOTE 2 This part of ISO 230 does not include non-contacting type of probes (e.g. optical probes), but it is intended that they be included in a future revision of this part of ISO 230.

## 2 Normative references

The following documents, in whole or in part, are normatively referenced in this document and are indispensable for its application. For dated references, only the edition cited applies. For undated references, the latest edition of the referenced document (including any amendments) applies.

ISO 230-1, *Test code for machine tools — Part 1: Geometric accuracy of machines operating under no-load or quasi-static conditions*

ISO 230-2, *Test code for machine tools — Part 2: Determination of accuracy and repeatability of positioning of numerically controlled axes*

ISO 230-3:2007, *Test code for machine tools — Part 3: Determination of thermal effects*

ISO 10360-5:2010, *Geometrical product specifications (GPS) — Acceptance and reverification tests for coordinate measuring machines (CMM) — Part 5: CMMs using single and multiple stylus contacting probing systems*

### **3 Terms and definitions**

For the purposes of this document, the following terms and definitions apply.

NOTE In measuring mode, machine tools are used like CMMs. Therefore, definitions for probing systems performance tests for CMMs apply also for machine tools. However, since not all machine tool users are familiar with the use of CMMs, this part of ISO 230 provides definitions specifically with machine tools in mind, making sure that they do not create any conflicts with CMM definitions.

#### **3.1 General terms**

##### **3.1.1**

##### **machine coordinate system**

##### **MCS**

coordinate system fixed with respect to physical or calculated axes of a machine tool

[SOURCE: ISO 10360-1:2000, 2.5 — modified.]

##### **3.1.2**

##### **workpiece coordinate system**

##### **WCS**

coordinate system fixed with respect to a workpiece

[SOURCE: ISO 10360-1:2000, 2.4]

##### **3.1.3**

##### **measuring volume**

three-dimensional space encompassing all linear coordinates that are accessible for measurement on the machine tool

[SOURCE: ISO 10360-1:2000, 2.3 — modified.]

#### **3.2 Terms relating to the probing system**

##### **3.2.1**

##### **probe**

device that senses a feature and generates the signal(s) during probing

[SOURCE: ISO 10360-1:2000, 3.1 — modified.]

Note 1 to entry: There are several types of probes used on machine tools and they use different technologies to achieve the same aim.

Note 2 to entry: Probes can either be “switching” types or “proportional” types. These are all available as either “contacting” or “non-contacting” systems. Non-contacting systems are not part of the scope of this part of ISO 230.

##### **3.2.1.1**

##### **switching probe**

probe that gives a binary signal as a result of contact with a surface being measured (detected)

##### **3.2.1.2**

##### **proportional probe**

probe that gives a signal (analogue or digital) proportional to a displacement of the stylus tip



### 3.2.1.3 contacting probe

probe that needs material contact with a surface being measured (detected) in order to function

[SOURCE: ISO 10360-1:2000, 3.2 — modified.]

EXAMPLE Electrical circuit breakage, strain gauge.

Note 1 to entry: The contacting feed speed applied to obtain the material contact can influence the performance of such probes. Proper contacting feed speed is specified in the manufacturer's/supplier's instructions.

Note 2 to entry: For best performance, the contacting feed speed applied during measurement is the same as the feed speed applied during probe qualification.

### 3.2.1.4 non-contacting probe

probe that needs no material contact with a surface being measured in order to function

[SOURCE: ISO 10360-1:2000, 3.3 — modified.]

EXAMPLE Optical and laser systems, inductive and capacitive systems.

Note 1 to entry: Non-contacting probes are not included in the scope of this part of ISO 230.

## 3.2.2 probing system

system consisting of a *probe* (3.2.1), signal transmission system (e.g. optical, radio, wire), signal conditioning hardware, the probing hardware and software and, where present, probe extensions, probe changing system, stylus and stylus extensions, when used in conjunction with a suitable numerically controlled machine tool

[SOURCE: ISO 10360-1:2000, 2.6 — modified.]

Note 1 to entry: Tests specified in this part of ISO 230 are referred to probing systems consisting of contacting probes equipped with a single stylus system that is parallel to the machine tool spindle axis average line, as depicted in [Figure 2](#). For applications using stylus systems equipped with multiple styli (see [Figure 3](#)), and for application where measurement is performed by using multiple orientations of the spindle axis average line with respect to the WCS, additional tests are specified in ISO 10360-5.

## 3.2.3 probing system qualification

establishment of the parameters of a probing system (based on manufacturer's/supplier's instructions) necessary for subsequent measurements

Note 1 to entry: *Effective stylus tip diameter* (3.2.5) and location of the stylus tip centre with respect to the MCS are typical parameters established by probing system qualification.

Note 2 to entry: Suppliers' technical literature sometimes refers to probing system qualification with the expression "probing system calibration"; this expression is not appropriate.

## 3.2.4 pre-travel

distance between the point of first material contact of the probe stylus tip with the surface being measured (detected) and the point where the probe signal is generated

Note 1 to entry: Pre-travel is affected by probe construction, probing direction, probing speed, switching force, stylus system length and compliance, time delay between probing signal and machine tool position transducer read-out, etc.

Note 2 to entry: Pre-travel variation (commonly referred to as "lobing"), under specified probing conditions, is a very important probing system characteristic.

Note 3 to entry: Some probe qualification techniques can significantly reduce the effects of probing system pre-travel variation.

3.2.5

**effective stylus tip diameter**  
**effective stylus tip size**

stylus tip dimension used by some probing software to compensate for measured feature size, etc.

Note 1 to entry: The effective stylus tip diameter (size) is associated with probing system performance and is determined by appropriate probing system qualification, rather than by simply measuring the stylus tip size.

3.2.6

**stylus tip**

physical element that establishes the contact with the object to measure

[SOURCE: ISO 10360-1:2000, 4.2 — modified.]

3.2.7

**stylus system**

system composed of a stylus and stylus extension(s) (if any)

[SOURCE: ISO 10360-1:2000, 4.4 — modified.]

Note 1 to entry: Stylus extensions can reduce stylus system stiffness and can adversely influence probing system performance. Therefore, performance tests are carried out using the particular stylus extension(s) of interest.

3.2.8

**stylus system length**

<spherical stylus tip> distance from the centre of the stylus tip to the shoulder of the stylus system

Note 1 to entry: See [Figure 1](#).

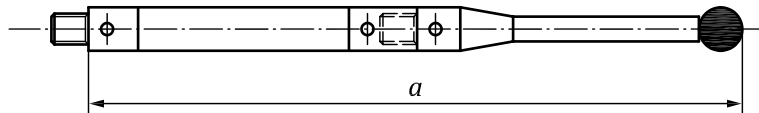

**Key**

a stylus system length

**Figure 1 — Stylus system length**

3.2.9

**probing tool**

device consisting of a probe and its stylus system, attached to a tool holder

Note 1 to entry: See [Figure 2](#).

3.2.10

**probing-tool length**

distance from the most protruding point of the stylus tip to the machine tool spindle reference surface or gauge line that connects to the probing tool

Note 1 to entry: See [Figure 2](#).

Note 2 to entry: Some probing systems establish the probing-tool length as the distance from the centre of the stylus tip surface to the machine tool spindle reference surface that connects to the probing tool.

Note 3 to entry: For solid-shank-type tool holders, the spindle reference surface is at the spindle cone gauge line. For other tool holders (hollow shank), the spindle reference surface is the spindle face.

Note 4 to entry: The procedure for establishing the length of the probing tool is specified in manufacturer's/supplier's instructions.

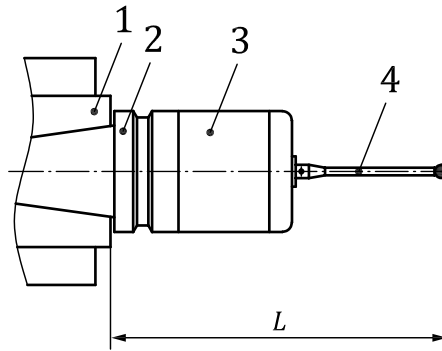
**Key**

- 1 spindle
- 2 tool holder
- 3 probe
- 4 stylus
- $L$  probing-tool length

**Figure 2 — Probing-tool length****3.2.11****stylus tip offset**

effective distance from the centre of the stylus tip to the axis average line of the spindle, in which the probing tool is mounted

**3.3 Terms relating to probing****3.3.1****probing****probe**

measurement action that results in the determination of values (e.g. coordinate values, length values, false/true values)

[SOURCE: ISO 10360-1:2000, 2.7 — modified.]

Note 1 to entry: Probing associated with the measurement of cutting tools does not necessarily result in the determination of coordinate values.

Note 2 to entry: Probing associated with tool breakage detection results in the determination of a false/true state.

**3.3.1.1****1D probing**

measurement allowing for probing motion parallel to one machine coordinate system axis or to one workpiece coordinate system axis at one time only

Note 1 to entry: 1D measurement capability is associated with the probing system performance, not only with the contacting probe capabilities.

**3.3.1.2****2D probing**

measurement allowing for probing motion along a vector in a plane

Note 1 to entry: Typical contacting probes that operate in the  $-X$ ,  $+X$ ,  $-Y$ ,  $+Y$  and  $-Z$  directions, and in any combination of such directions, are sometimes referred to as 2,5D probes. These contacting probes do not allow for (or allow for very limited) traction in the  $+Z$  direction.

Note 2 to entry: Measurement in the +Z direction capability can be obtained by the use of stylus systems equipped with multiple styli, as depicted in [Figure 3](#), where stylus tip 2 (moving in the +Z direction) contacts the workpiece surface and causes the probe to generate the signal as a consequence of the deflection in the -Z direction.

Note 3 to entry: Independent qualification for stylus tip 1 and for stylus tip 2, and additional tests, are specified in ISO 10360-5.

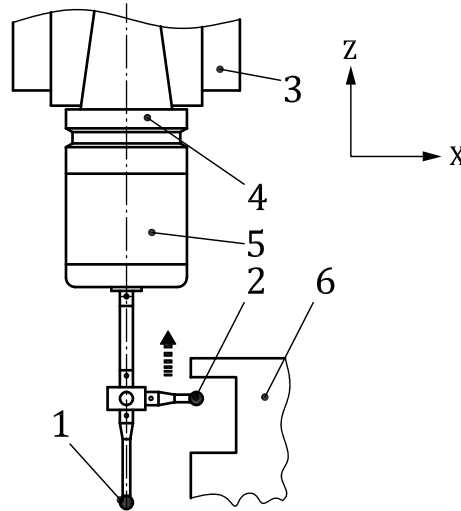

**Key**

- 1 stylus tip 1
- 2 stylus tip 2
- 3 spindle
- 4 tool holder
- 5 probe
- 6 workpiece

**Figure 3 — Probing-tool equipped with 2 styli**

**3.3.1.3**

**3D probing**

measurement allowing for probing motion along any vector in space

**3.3.2**

**probing repeatability**

degree of closeness of coordinate values provided by the probing system when it is repeatedly applied to the same measurand under the same test conditions

Note 1 to entry: This definition specifically refers to the scope of this part of ISO 230 and the probing systems under test; it is not extended to the general definition associated with the metrological characteristics defined in other International Standards.

Note 2 to entry: Probing repeatability can be expressed quantitatively in terms of the dispersion characteristics of the measured values or by the range of measured values.

Note 3 to entry: Probing repeatability relates to the complete probing system. It is not comparable with “probe repeatability” as defined in the probe suppliers’ handbooks.

### 3.3.3 probing error

$P_{FTU}$

error within which the range of the radii of a reference artefact can be determined by a machine tool using one stylus system

Note 1 to entry: The symbol,  $P_{FTU}$ , is taken from ISO 10360-5:2010, 3.6 and 3.9. The character  $P$  indicates that the error is related primarily to the probing system performance, the character  $F$  indicates that it is a form error, the character  $T$  refers to a contacting (tactile) probing system and the character  $U$  indicates the use of a single (unique) stylus.

Note 2 to entry: A typical reference artefact for 2D probing is a ring calibrated for form. A typical reference artefact for 3D probing is a sphere calibrated for form.

Note 3 to entry: 2D probing error is addressed in [6.5](#) and 3D probing error is addressed in [6.6](#).

## 3.4 Terms relating to scanning probes (See [Annex B](#))

### 3.4.1 rest position

position of the centre of the probe's stylus tip when it is stationary and not deflected by contact with a surface

Note 1 to entry: The rest position is a nominal position that is established during qualification. The actual rest position at any time typically varies slightly from this value.

### 3.4.2 maximum scanning deflection

maximum deflection that can be applied to the centre of the probe's stylus tip during a scanning measurement specified by the manufacturer

Note 1 to entry: The maximum scanning deflection can vary with direction of deflection ( $x,y,z$ ).

### 3.4.3 probe over-travel limit

maximum deflection of the centre of the probe stylus tip from the rest position that can be applied without causing damage to the probe stylus assembly

### 3.4.4 minimum scanning deflection

minimum deflection of the centre of the stylus tip from its rest position that is allowed during a scanning measurement

Note 1 to entry: Deflection is programmed to be large enough to ensure that the stylus tip maintains contact with the surface throughout the measurement.

### 3.4.5 scanning measurement range

maximum allowed distance between the nominal scan line and the actual scan line, as specified by the manufacturer/supplier

Note 1 to entry: This distance may be expressed separately for the different axes of the probe, e.g.  $\pm 0,3$  mm in  $X$  and  $Y$ ,  $\pm 0,2$  mm in  $Z$ .

Note 2 to entry: The scanning measurement range is less than the difference between the maximum scanning deflection and the minimum scanning deflection for a number of reasons, including

- deviation from the pre-defined tool-path caused by machine tool path following errors,
- approximations during tool-path generation (e.g. approximating a curve by straight line segments), and

— additional probe deflection caused by movement along the surface (e.g. friction, local surface normal deviations, surface finish).

**3.4.6**

**stylus tip normal acceleration**

acceleration of the centre of the stylus tip relative to the surface being measured, normal to the target surface

Note 1 to entry: Stylus tip normal acceleration is sometimes considered to limit the scanning feed speed for features that have sharp scanning path variations, and would therefore demand high rates of acceleration from the machine tool axes. Scanning performance is affected mostly by acceleration normal to the surface being measured, as machine position errors in the direction of the target scan line do not usually lead to significant measurement errors.

**3.4.7**

**indicated tip centre point**

indicated position of the centre of the stylus tip during a measurement

Note 1 to entry: This is also known as an “indicated measured point” (see ISO 10360-1:2000, 2.12).

**3.4.8**

**scanning sphere centre position reproducibility**

maximum variation of the sphere centre positions obtained through multiple measurements compared to the sphere centre position obtained by the first measurement

**3.4.9**

**pre-defined path scanning**

method of scanning in which the motion of the probing system between two defined end points is directed by a target scan line

[SOURCE: ISO 10360-1:2000, 7.5]

Note 1 to entry: In this method of scanning, feedback from the probing system is not used to direct the motion of the probing system.

**4 Preliminary remarks**

**4.1 Influences on the measurement performance of the probing system**

Measurement performance of the probing system includes the machine tool characteristics over a limited, small volume and shall not be simply derived from the stand-alone probe specifications.

The main influences on performance of probing systems of a machine tool are the following:

- a) repeatability of machine tool;
- b) geometric accuracy of machine tool, i.e. positioning accuracy (including resolution, backlash), straightness, roll, pitch, yaw error motion, squareness between axes, etc.;
- c) contamination of surfaces being measured (detected);
- d) probing error and repeatability of probing system, including probing-tool changing and relocation;
- e) probing system qualification;
- f) temperature influences on machine tool, probing system, artefact and workpiece/tool, including drift of moving axes and spindles;
- g) feed speed and accelerations during measurement;
- h) standoff and overtravel distances;

- i) time delay and time delay variation between probing signal and read-out of machine tool position transducers;
- j) surface of workpiece/tool probed.

Workpiece probing repeatability shall be checked in accordance with the tests in [6.2](#); probing-tool location repeatability shall be checked in accordance with the test in [6.4](#); tool setting repeatability shall be checked in accordance with the tests in [7.3](#).

Testing for performance of workpiece probing system and geometric accuracy of the machine tool (in a limited, small volume) is given in [6.5](#) and [6.6](#).

Testing for time delay variation between probing signal and read-out of machine position transducers is given in [6.9](#); feature size measurement performance tests are given in [6.10](#).

Temperature influences are best observed using procedures given in [5.2](#) and in ISO 230-3.

## 4.2 Measurement units

In this part of ISO 230, all linear dimensions and deviations are expressed in millimetres. All angular dimensions are expressed in degrees. Angular deviations are, in principle, expressed in ratios but in some cases, microradians or arc-seconds may be used for clarification purposes. The following expression should be used for conversion of the units of angular deviations or tolerances:

$$0,010/1\ 000 = 10\ \mu\text{rad} \approx 2''$$

## 4.3 Reference to ISO 230-1

To apply this part of ISO 230, reference should be made to ISO 230-1, especially for the installation of the machine before testing.

## 4.4 Recommended instrumentation and test equipment

The measuring instruments indicated in the tests described in the following clauses are examples only. Other instruments measuring the same quantities and having the same or smaller measurement uncertainty may be used. Linear displacement sensors shall have a resolution of 0,001 mm or better.

## 4.5 Machine conditions prior to testing

Before starting the measurements, the machine tool geometric performance shall be assessed in accordance with relevant International Standards (e.g. ISO 230-1, ISO 230-2, ISO 230-3, ISO 10791-1).

NOTE Appropriate national standards can apply.

In addition, the procedures for probe configuration and qualification shall be performed according to the conditions specified by the manufacturer/supplier.

## 4.6 Testing sequence

The sequence in which the tests are presented in this part of ISO 230 does not define the practical order of testing. The tests described in [Clauses 5, 6](#) and [7](#) may be performed either singly or in any combination.

## 4.7 Tests to be performed

When testing a machine, it is neither always necessary nor possible to carry out all the tests described in this part of ISO 230. When the tests are required for acceptance purposes, it is up to the user to choose, in agreement with the manufacturer/supplier, those tests which are of interest. These tests shall be clearly stated when ordering a machine. Mere reference to this part of ISO 230 for the acceptance tests,



without specifying the tests that shall be carried out, and without agreement on the relevant expenses, cannot be considered binding for any contracting party.

### 4.8 Sources of test uncertainty

The tests described in this part of ISO 230 reveal the characteristics of the probing system as a measuring instrument. Therefore, they are characteristically different from the tests described in other parts of ISO 230. For example, when testing the repeatability of positioning of a numerically controlled machine tool axis, the aim is to determine the repeatability of a specific machine tool characteristic under specified repeated measurement conditions. It shall be considered that this part of ISO 230 focuses on the determination of the performances of a specific measuring system: the probing system itself; therefore, consideration is made to estimate test uncertainty components rather than measurement uncertainty components as specified by ISO/TR 230-9.

Valuable information may be gathered from ISO/TS 23165.

The main contributors to the test uncertainty for probing system measurement performance tests are as follows:

- the uncertainty of the calibration of the reference artefact, i.e. test ring or test sphere, where applicable;
- the alignment of the reference ring(s), where applicable;
- the fixturing of the reference artefact, where applicable;
- the compensation of thermally induced errors, when measuring at temperatures outside the manufacturer's/supplier's environmental temperature guidelines, performed in accordance with [5.1](#);

NOTE If tests are performed at temperatures complying with the manufacturer's/supplier's guidelines or if no environmental temperature guidelines are given, the test results properly represent the metrological characteristics of the probing system under test; therefore, there is no contribution to the test uncertainty.

- the environmental temperature variation error (ETVE or drift) during the time of measurement, respectively the repeatability of the measurements due to the actual test environment exceeding the manufacturer's/supplier's environmental temperature guidelines.

### 4.9 Reporting of test results

Relevant parameters of the test shall be reported, including the following:

- a) identification of machine tool;
- b) identification of measuring software;
- c) identification of probe/sensor;
- d) identification of stylus system components and length;
- e) probe switching force setting, where applicable;
- f) position and orientation of the probe/sensor, if not fixed by design of the machine tool;
- g) type, dimension and identification of artefact or tool measured;
- h) location of the artefact in the machine tool measuring volume, where applicable;
- i) feed speed during probe qualification and during test;
- j) probing distance during probe qualification and during test;
- k) probing points number and distribution;
- l) programmed spindle speed, where applicable;



- m) relevant machine temperatures and ambient temperatures;
- n) warm-up cycle.

## 5 Thermal influences

### 5.1 General

According to ISO 1, the reference temperature for industrial dimensional measurements is 20 °C; therefore, the measuring instruments and the measured objects should be in equilibrium with the environment where the temperature is kept at 20 °C. If the environment is at a temperature other than 20 °C, nominal differential thermal expansion (NDE) correction between the measurement system and the measured object shall be made to correct the results to correspond to 20 °C. Built-in NDE correction, used for the normal operation of the machine tool, shall be used; additional NDE correction, just for the measurements, shall not be used to correct the thermal distortions of machine position transducers.

### 5.2 Environmental temperature variation error (ETVE) test

An ETVE test (as specified in ISO 230-3:2007, Clause 5) shall be conducted prior to the probe evaluation tests. The duration of the ETVE test should be agreed on between the manufacturer/supplier and user and should include the anticipated probing time.

ETVE tests are designed to reveal the effects of environmental temperature changes on the machine. They shall not be used for machine comparison.

The manufacturer/supplier (of the machine tool or of the probing system) shall define the thermal environment in which the specified probing system performance can be achieved. It shall be the responsibility of the user to provide an acceptable thermal environment for the probing operation. However, if the user follows the guidelines provided by the probing system/machine manufacturer/supplier, or if no guidelines are provided, the responsibility for probing performance according to the specification reverts to the machine tool or probing system manufacturer/supplier.

If probing capability is added to an existing machine, specification for thermal environment is subject to an agreement between the manufacturer/supplier and the user.

The ETVE test shall be performed probing a sphere/a ring/a plane several times and evaluating the change of the sphere centre/circle centre coordinates or the plane location. The test should last for a period that equates to the nominal duration of the probing system tests.

The presentation of the results shall be in accordance with ISO 230-3:2007, 5.3.

### 5.3 Other thermal distortion tests

If the probing system is applied just after machining operations or between machining operations, the effects of cooling of the machine tool, especially the machine tool spindle, shall be considered. In such cases, a temperature variation error test shall be carried out after warming up of the main spindle and/or machine tool axes, e.g. by performing movements of a typical machining operation prior to measurements. The machine tool movements that shall be performed (for instance spindle speed, duration of movement, movement of axes, feed speeds) for the temperature variation error test are subject to agreement between the manufacturer/supplier and user and shall consider the typical operations of the machine tool.

Individual performance tests in [Clauses 6](#) and [7](#) may be carried out after performing typical movements corresponding to machining operations, which are subject to agreement between the manufacturer/supplier and user.

## 6 Probing of workpiece

### 6.1 General

Probes used on machining centres for the probing of workpiece are typically connected to the machine tool spindle. For many probing applications, the centre of the stylus tip should be located on the spindle axis average line in order to allow for proper identification of the workpiece coordinate system (WCS) with respect to the machine coordinate system (MCS). In other typical applications (for example: measurement of the distance between two nominally parallel machined surfaces, measurement of the diameter of a hole or a boss, etc.), where the alignment of the stylus tip to the spindle axis average line is not of primary concern, care should be taken to ensure that the spindle orientation with respect to the MCS does not change during subsequent probing in order to avoid the stylus tip offset becoming a significant component of probing error.

Prior to test execution, stylus tip on-centre adjustment shall be performed according to the manufacturer's/supplier's instructions. The adjustment procedure shall be repeated whenever the stylus system connection to the probe is altered. This includes disassembling and re-assembling the same stylus tip as different assembling torques can possibly change the stylus tip centre position.

Probing system qualification shall be performed according to the manufacturer's/supplier's instructions and shall be repeated after stylus tip on-centre adjustment.

Suppliers' technical literature sometimes refers to probing system qualification with the expression "probing system calibration"; this expression is not appropriate and should be avoided.

Tests in this part of ISO 230 are presented assuming that the probing system is aligned with the machine tool Z-axis of motion and that the stylus tip centre is aligned with the spindle axis average line, assumed to be nominally parallel to the Z-axis of motion. For applications using tilting or indexing heads, for any new orientation, probing system qualification shall be performed again. For such applications, use of ISO 10360-5 is recommended.

The user is free, where applicable, to choose the location in which to mount the reference artefact within the specified measuring volume. However, the reference artefact shall not be placed at a location used for the probing system qualification.

The reference artefact should always be mounted and clamped to ensure sufficient setup rigidity when submitted to the specific probing system switching force, yet avoiding deformation of the artefact. Machine tool probe switching force may vary from as little as 0,2 N for strain gauge switching probes to a few newtons for conventional switching probes. Switching force for the Z-axis direction is typically significantly higher than the X- and Y-axis direction switching force.

### 6.2 Probing repeatability

#### 6.2.1 General

Typical workpiece probing systems for machining centres offer measuring capabilities designed to perform quick, simplified in-process measurements and measurement of the workpiece after machining, but while still on the machine. Such systems usually provide information on the size and the location of workpiece features, such as holes, bosses, web, pockets, corners and single-point surface measurements, but they usually do not provide evaluation of form error of the measured workpiece feature.

Enhanced machine tool probing systems exist that offer complex measurement capabilities, such as measurement of free-form deviation from the mathematical model. Other probing systems allow for the implementation of measurement strategies that are typically available only on CMMs.

Probing repeatability should, in principle, be associated with every single measuring task that can be performed by a specific probing system. This approach would lead to a significant testing effort that is considered to be unjustified.

A workpiece probing system is typically used for workpiece position and orientation measurements aimed at locating the WCS with respect to the MCS, and for simple feature location and size measurements. Probing repeatability tests are therefore specified for flat-surface location measurements, and cylinder and sphere centre location measurements.

Probing repeatability for size measurements is addressed in [6.10](#).

## **6.2.2 Probing repeatability test for single-point surface measurement, $R_{SPT,X}$ , $R_{SPT,Y}$ and $R_{SPT,Z}$ ( $R_{Single\_Point,X,Y,Z}$ )**

### **6.2.2.1 General**

It shall be noted that single-point surface measurement is an extremely simplified measuring method. The determination of the coordinates of a single point of a (flat) surface can be assumed to individually represent the (flat) surface itself only when the orientation and position of the surface with respect to the relevant coordinate system are known.

### **6.2.2.2 Test setup and procedure**

Select a test artefact (block) with at least three flat surfaces nominally square to each other. For most applications, a standard gauge block, with side surfaces' flatness within 0,080 mm is adequate for this test.

NOTE The test artefact referred to in [6.7.2](#) can also be suitable for this test.

Align the test artefact to the MCS in order to orient the three planes square to the X-, Y- and Z-axis, respectively.

Acquire and record the X-axis coordinate of a contact point approaching the test artefact surface in the X-axis direction. Repeat the acquisition and the recording of the X-axis coordinate values nine times for a total of ten measurements.

Repeat the procedure for the Y-axis and for the Z-axis.

### **6.2.2.3 Analysis of results**

Compute  $R_{SPT,X}$  as the range of recorded values for the X-axis coordinate.

Compute  $R_{SPT,Y}$  as the range of recorded values for the Y-axis coordinate.

Compute  $R_{SPT,Z}$  as the range of recorded values for the Z-axis coordinate.

## **6.2.3 Probing repeatability test for circle centre location, $R_{CIR,X}$ and $R_{CIR,Y}$ ( $R_{CIRcle,X,Y}$ )**

### **6.2.3.1 Test setup and procedure**

Set up a reference ring with a bore diameter of approximately 25 mm and align it to the MCS in order that the axis of the ring bore is parallel to the Z-axis of the machine.

Measure the centre coordinates of the reference ring bore by probing it with four points. Establish a WCS datum point at the measured centre.

Repeat the measurement ten times, recording the bore centre X- and Y- axis coordinates.

### **6.2.3.2 Analysis of results**

Compute  $R_{CIR,X}$  as the range of recorded values for the X-axis coordinate of the centre.

Compute  $R_{CIR,Y}$  as the range of recorded values for the Y-axis coordinate of the centre.

**6.2.4 Probing repeatability test for sphere centre location,  $R_{SPH,X}$ ,  $R_{SPH,Y}$  and  $R_{SPH,Z}$  ( $R_{SPH,Here, X,Y,Z}$ )**

**6.2.4.1 Test setup and procedure**

Set up a reference sphere with a nominal diameter of approximately 25 mm.

Measure the centre coordinates of the reference sphere by probing it with five points according to the manufacturer's/supplier's instructions. Establish a WCS datum point at the measured centre of the reference sphere.

Repeat the measurement ten times, recording the sphere centre X-, Y- and Z-axis coordinates.

**6.2.4.2 Analysis of results**

Compute  $R_{SPH,X}$  as the range of recorded values for the X-axis coordinate of the sphere centre.

Compute  $R_{SPH,Y}$  as the range of recorded values for the Y-axis coordinate of the sphere centre.

Compute  $R_{SPH,Z}$  as the range of recorded values for the Z-axis coordinate of the sphere centre.

**6.3 Stylus tip offset test,  $A$**

**6.3.1 General**

Prior to test execution, the stylus tip shall be centred to the spindle axis average line according to the manufacturer's/supplier's instructions.

Some enhanced probing system allow for automatic detection and compensation of stylus tip offset. If such performance exists, the relevant manufacturer's/supplier's procedure shall be executed before test execution.

**6.3.2 Test setup and procedure**

Locate a reference ring (or a reference sphere) within the machine tool measuring volume. When a reference ring is being used, align it to the MCS in order that the axis of the ring bore is parallel to the Z-axis of the machine.

Centre the reference ring bore (or the sphere) to the spindle axis average line by using a linear displacement sensor and establish a WCS datum point at the identified centre.

Measure the centre coordinates of the reference ring bore (or the centre of the equator of the reference sphere) by probing it with four points. Repeat the measurement ten times, recording the centre X- and Y-axis coordinates.

**6.3.3 Analysis of results**

Calculate  $X_0$  as the average of the ten measured X-axis coordinates and  $Y_0$  as the average of the ten measured Y-axis coordinates.

The offset,  $A$ , of the stylus tip to the spindle axis average line, is given by Formula (1):

$$A = \sqrt{X_0^2 + Y_0^2} \tag{1}$$

The calculated value for  $A$  shall be noted as a possible component to subsequent tests measurement uncertainty.

NOTE Stylus tip offset determined by this procedure includes the probing error,  $P_{FTU,2D}$  (see 6.5).

## 6.4 Probing-tool location repeatability test, $R_{PTL,X}$ , $R_{PTL,Y}$ and $R_{PTL,Z}$ ( $R_{\text{Probing-Tool\_Location,X,Y,Z}}$ )

### 6.4.1 General

The aim of this test is to evaluate the repeatability of the relocation of the probing tool with respect to the MCS after a manual or an automatic tool change.

### 6.4.2 Test setup and procedure

Set up a reference ring with a bore diameter of approximately 25 mm and align it to the MCS in order that the axis of the ring bore is parallel to the Z-axis of the machine.

- a) Measure the centre coordinates of the reference ring bore by probing it with four points and measure the reference ring top surface by single-point probing. Establish a WCS datum point at the measured centre of the reference ring and at the measured reference ring top surface.
- b) Repeat the measurement, recording the bore centre X- and Y-axis coordinates and the Z-axis coordinate.
- c) Remove and relocate the probing tool. If intended use foresees the use of an automatic tool changer, before the probe is returned to the spindle, the tool changer shall be indexed by at least one position and returned in order to include the repeatability of this system.
- d) Repeat the procedure nine times, starting from item b), in order to perform a total of ten measurements.

In some high-speed milling applications, the tool holder is not provided with driving dogs. In such applications, the relative angular position between the spindle and the probing tool is not controlled. It is therefore recommended to complement item c) by subsequently incrementing the relative angular position by approximately 15°.

A reference sphere may be used instead of the reference ring, unless otherwise stated by the manufacturer/supplier. When using a reference sphere, the sphere shall be probed with five points. The WCS datum point shall be established at the measured centre of the sphere.

### 6.4.3 Analysis of results

Compute  $R_{PTL,X}$  as the range of the recorded values of the X-axis coordinate of the bore centre.

Compute  $R_{PTL,Y}$  as the range of the recorded values of the Y-axis coordinate of the bore centre.

Compute  $R_{PTL,Z}$  as the range of the recorded values of the Z-axis coordinates of the top surface.

If a reference sphere is used,  $R_{PTL,X}$ ,  $R_{PTL,Y}$  and  $R_{PTL,Z}$  shall be computed as the range of the recorded values of X, Y and Z coordinates of the sphere centre.

## 6.5 2D probing error test, $P_{FTU,2D}$ ( $P_{\text{Form\_Tactile\_Unique,2D}}$ )

### 6.5.1 General

The aim of this test is to evaluate the 2D probing error of a particular probing system by measuring a reference ring calibrated for form. This error is strongly influenced by the probing system pre-travel variation, which is itself influenced by

- a) probing system and machine tool repeatability,
- b) probe switching force,
- c) stylus system length and construction,



- d) measurement feed speed,
- e) approaching distance for measurement points,
- f) probe qualification,
- g) variation of time delay between probing signal and read-out of machine tool position transducers,
- h) vibrations, and
- i) thermal drifts.

NOTE Some enhanced probing systems can apply software compensation to minimize pre-travel variation.

[Figure 4](#) shows a representation of 2D probing error for a typical probing system.

Relevant parameters, such as probe switching force, stylus system component length and material composition (e.g. steel, ceramics, carbon fibre), measurement feed speed and approaching distance for measuring points shall be conforming to the manufacturer's/supplier's specification. If some parameters are not specified, the user shall select them according to the intended use.

The number of probing points shall be agreed on between the manufacturer/supplier and the user, taking into account the intended use and the capabilities of the probing system. It is nevertheless recommended to acquire the coordinates of 36 points equally spaced along the ring circumference.

### 6.5.2 Test setup and procedure

Set up a reference ring with a bore diameter of approximately 25 mm and align it to the MCS in order that the axis of the ring bore is parallel to the Z-axis of the machine.

Measure the centre coordinates of the reference ring bore by probing it with four points. Establish a WCS datum point at the measured centre of the reference ring.

Next, probe the reference ring in radial directions with the acquisition of the chosen number of points equally spaced along the ring circumference, recording the X- and Y-axis coordinates of every single point.

### 6.5.3 Analysis of results

The centre of the measured circle is computed using the manufacturer/supplier-recommended algorithms (e.g. the least square best fit). The coordinates of this centre shall be subtracted from the X- and Y- coordinates of each point. For each of the measured points, radial distance,  $r$ , to the centre is calculated as the square root of the sum of the squares of these coordinate differences.

Calculate the probing error,  $P_{FTU,2D}$ , as the range of the measured radial distances,  $r_{\max} - r_{\min}$ .

The probing error,  $P_{FTU,2D}$ , can be represented on a polar plot (see [Figure 4](#)).

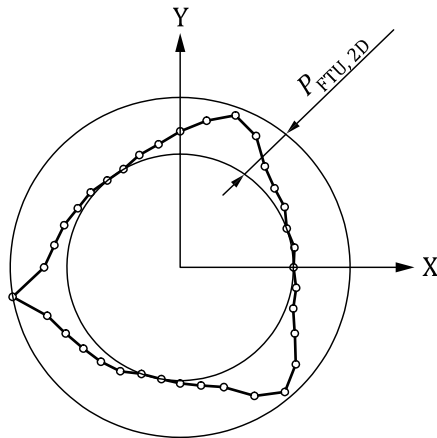

Figure 4 — Example of polar plot of  $P_{FTU,2D}$  values for a 36-point test

## 6.6 3D probing error test, $P_{FTU,3D}$ ( $P_{Form\_Tactile\_Unique,3D}$ )

### 6.6.1 General

This test is similar to the test specified in 6.5 but its aim is to test the performance of a probing system with 3D capabilities. The general information presented in 6.5.1 is also applicable, but the reference artefact is a sphere calibrated for form.

Typical probing systems propose sphere measurement by a very limited number of probing points (usually four or five points). Although intended use shall be taken into due account, it is considered that the execution of the test described in this clause can provide valuable information for a better understanding of the probing system performance.

The number of probing points shall be agreed on between the manufacturer/supplier and the user, taking into account the intended use and the capabilities of the probing system. It is nevertheless recommended to acquire the coordinates of 25 points approximately evenly distributed over at least a hemisphere of the test sphere.

### 6.6.2 Test setup and procedure

A reference sphere with a nominal diameter of approximately 25 mm shall be used. The form of the reference sphere shall be calibrated, since the form error influences the test results, and shall be taken into account for proving conformance or non-conformance with the specifications.

Measure the centre coordinates of the reference sphere by probing it with five points. Establish a WCS datum point at the measured centre of the reference sphere.

Probe the reference sphere in 3D radial vector directions with the acquisition of the chosen number of points, which are approximately evenly distributed over at least a hemisphere of the test sphere. Their position shall be at the discretion of the user and, if not specified, the following probing pattern is recommended (see Figure 5):

- one point on the pole (defined by the direction of the spindle axis) of the reference sphere;
- four points (equally spaced)  $22,5^\circ$  below the pole;
- eight points (equally spaced)  $45^\circ$  below the pole and rotated  $22,5^\circ$  relative to the previous group;
- four points (equally spaced)  $67,5^\circ$  below the pole and rotated  $22,5^\circ$  relative to the previous group;
- eight points (equally spaced)  $90^\circ$  below the pole (i.e. on the equator) and rotated  $22,5^\circ$  relative to the previous group.

The number of probing points and the recommended target positions have been selected for compatibility with ISO 10360-5:2010, 6.2. For some applications, this test may be performed by probing 48 points, approximately evenly distributed over at least a hemisphere of the test sphere.

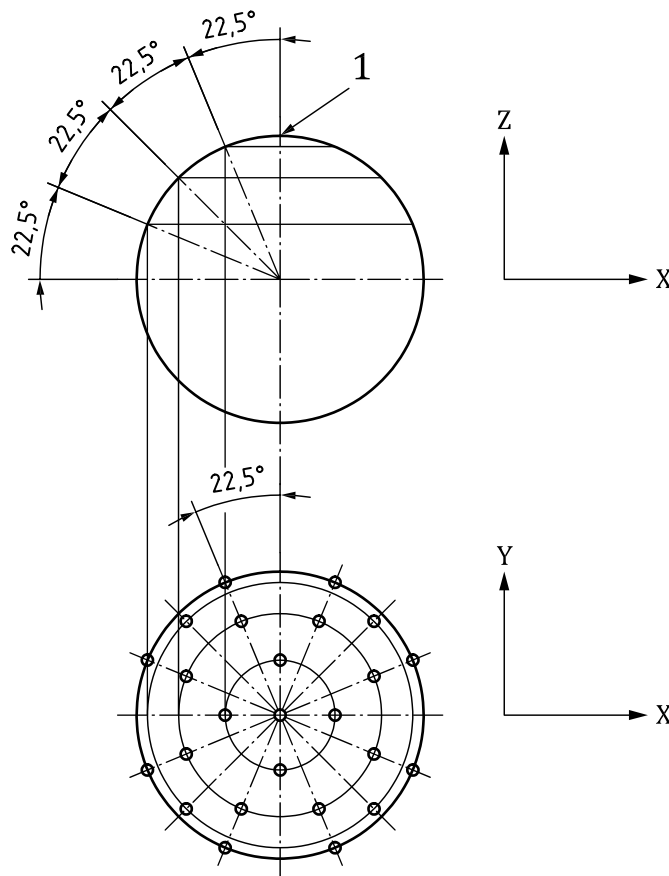

Key  
1 pole

Figure 5 — 3D target contact points for 3D probing error test  $P_{FTU,3D}$

### 6.6.3 Analysis of test results

Using all available measurements, the sphere centre is computed using the manufacturer/supplier-recommended algorithms (e.g. the least square best fit). The coordinates of this centre shall be subtracted from the X-, Y- and Z-axis coordinates of each point. For each point, radial distance,  $r$ , to the centre is calculated as the square root of the sum of the squares of these coordinate differences.

Calculate the probing error  $P_{FTU,3D}$  as the range of radial distances  $r_{max} - r_{min}$ .

### 6.7 Workpiece position and orientation tests, $E_{PLA,Z}$ , $E_{LIN,Y}$ , $E_{COR,X}$ , $E_{COR,Y}$ and $E_{COR,Z}$ ( $E_{PLAne,Z}$ ), ( $E_{LINE,Y}$ ), ( $E_{CORner}$ coordinates,X,Y,Z)

#### 6.7.1 General

In many applications, probing on a machine tool is used to reference a workpiece within the MCS and to locate it with respect to the spindle axis average line. These tests are designed to evaluate this ability of the probing system.



Best practice suggests that the proper identification of the WCS with respect to the MCS is performed in the following sequence:

- a) identification of the WCS reference plane;
- b) identification of the WCS orientation in the reference plane;
- c) definition of the WCS datum point.

If some steps of the suggested sequence are not performed (sometimes justified by projected time saving), assumptions are made that (if not corresponding to the real situation) can result in improper WCS identification.

#### **6.7.1.1 Identification of the WCS reference plane**

On a machining centre, the workpiece is connected to the machine tool table (or connected to a support which is connected to the machine table).

There would be no need to identify the WCS reference plane (assumed to be parallel to the XY plane) if it can be assumed that

- a) the machine tool table (or the workpiece support) is flat and parallel to the X- and Y-axes of motion (that define the machine tool XY coordinate plane),
- b) the bottom surface of the workpiece is parallel to its reference surface, and
- c) there are no disturbing elements (e.g. scratches, dirt, residual chips, etc.) influencing the connection between the workpiece and the table (or support).

When some of these conditions are not fulfilled, it can be advantageous to measure the workpiece reference plane in order to identify it, as an alternative to physically adjusting the workpiece itself.

Typical probing systems allow for measurement of a (nominally flat) workpiece reference surface by probing three points. Other sophisticated probing systems can offer the option to define the workpiece reference surface by multiple probing on a (known) surface, comparing the measured surface points to the mathematical model for the surface and applying best-fit strategies.

#### **6.7.1.2 Identification of the WCS orientation in the reference plane**

Typical probing systems allow for alignment of the WCS orientation in the reference plane by defining a line passing through two measured points on a (nominally) flat surface or passing through the centre coordinates of two cylindrical or spherical workpiece features.

It shall be noted that, if the workpiece reference plane was not adjusted to be parallel to the machine tool XY coordinate plane (or measured and compensated for), the measurement of a line would not properly identify the WCS orientation in the reference plane.

#### **6.7.1.3 Location of the WCS datum point**

Typical probing systems allow, at least, for the location of a datum point by combining the following capabilities:

- a) setting of individual axes datum points by probing a point on a plane;
- b) setting of the X- and Y-axis datum point on the corner between two planes or on the centre of a hole or boss;
- c) setting of the X-, Y- and Z-axis datum point on the centre coordinate of a sphere or on a corner identified as the intersection of three planes.

**6.7.1.4 Influence of probing system characteristics on workpiece coordinate system (WCS) identification**

6.7.1.4.1 The main probing system characteristics that influence the identification of the WCS are

- a) probing system repeatability (see 6.2),
- b) stylus tip offset error with respect to the spindle axis average line (see 6.3),
- c) probing-tool location repeatability (see 6.4),
- d) probing error (see 6.5 and 6.6),
- e) effective stylus tip diameter (see 6.10),
- f) variation of time delay between probing signal and read-out of machine tool position transducers (see 6.9),
- g) probe qualification, and
- h) thermal drifts.

Table 1 presents a simplified representation of the influence of main characteristics on some common measuring tasks to possibly help define probing strategies.

NOTE 1 Probing repeatability, variation of time delay, probe qualification and thermal drifts are not listed in Table 1 because, in practical terms, they influence all measuring tasks.

NOTE 2 Blank cells denote a very weak or insignificant influence of the specific characteristic on the measuring task.

NOTE 3 Assumption is made that WCS identification procedure is performed without intermediate probing-tool changes.

**Table 1 — Simplified representation of the influence of probing system characteristics on measuring tasks**

Measuring task	Stylus tip offset <sup>a</sup>	Probing-tool location repeatability <sup>b</sup>	Probing error <sup>c</sup>	Effective stylus tip diameter <sup>d</sup>
Single point surface detection	strong X, Y	strong	strong X, Y	strong
Angle of XY reference plane				
Angle of a line by two points				
Angle of a line passing through two centres				
Location of a line by two points	strong X, Y	strong	strong	strong
Location of a corner on a plane	strong X, Y	strong X, Y	strong	strong
Location of a corner as intersection of three planes	strong X, Y	strong	strong	strong
Centre location for a hole or boss	strong X, Y	strong	medium	
Centre location of a sphere	strong X, Y	strong	medium	
<sup>a</sup> See 6.3. <sup>b</sup> See 6.4. <sup>c</sup> See 6.5 and 6.6. <sup>d</sup> See 6.10.				

6.7.1.4.2 Analysis of Table 1 and good practice would suggest the following:

- a) identification of the WCS reference plane by probing a minimum of three points on a workpiece plane;
- b) identification of the orientation of the WCS in the reference plane by probing a line by two points (or more, if available) or by a line passing through the centre of two circles;
- c) definition of the WCS X- and Y-axis datum point as the centre coordinates of a hole or boss;
- d) definition of the WCS Z-axis datum point as the average of repeated single axis measurements (thus minimizing the effect of stylus tip alignment, probing-tool location repeatability and pre-travel variation that is virtually insignificant for the Z direction).

The WCS Z-axis datum point can also be defined by the WCS reference plane. If this feature is used, no additional probing for the Z-axis datum point is necessary.

### 6.7.2 Test setup

Select a test artefact similar to the one depicted in [Figure 6](#). The proposed artefact has a cubic form with a side length of approximately 50 mm. The bore has a diameter of approximately 25 mm. Planes A, B and D should preferably be ground and the geometrical characteristics of the test artefact should be known from previous measurement, e.g. on a CMM.

The proposed test artefact may also be used for periodic reverification of probing system performance.

Position the test artefact in a workpiece-representative position within the machine tool measuring volume and mount it deliberately skewed by approximately  $1^\circ$  in three directions with respect to the MCS.

Some probing systems only offer an alignment capability in the XY plane. In such cases, the test artefact shall be mounted with its top plane A parallel to the machine tool XY plane and one of its sides out of alignment with respect to the MCS by approximately  $1^\circ$ . In this case, step a) 1) of the test procedure given in [6.7.3](#) shall not be executed.

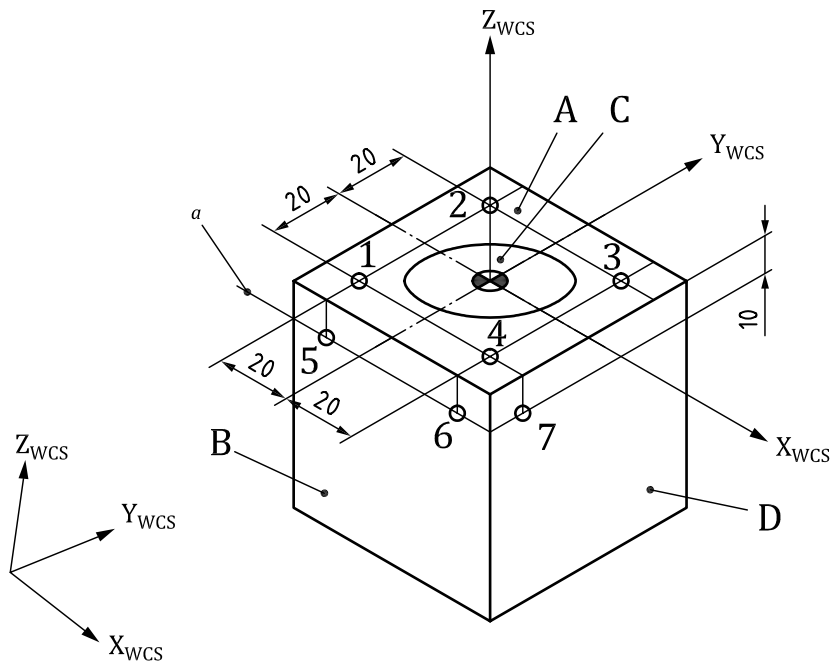

**Key**

- A plane A
- B plane B
- C bore C
- D plane D
- a Line L.
- 1 to 7 measuring points for WCS position and orientation verification

**Figure 6 — Sample WCS position and orientation test artefact**

**6.7.3 Test procedure**

Workpiece features shall be identified by probing them with the number of points that corresponds to the probing system’s intended use and applying the following procedure.

- a) Phase 1: WCS orientation and position identification.
  - 1) Set the WCS reference plane by probing the test artefact plane A (see [Figure 6](#)).
  - 2) Set the orientation of the WCS in the reference plane by probing line L on the test artefact plane B (see [Figure 6](#)).

NOTE 1 Best practice would suggest probing plane B as a plane, intersecting plane B with plane A and using the intersecting straight line as the orientation of the WCS in the reference plane A.

- 3) Set the WCS X- and Y-axis datum point by probing the bore C (see [Figure 6](#)).
- 4) Set again the WCS X- and Y-axis datum point by probing the bore C.

NOTE 2 This repeated operation is needed to minimize the effect of time delay between probing signal and read-out of machine tool position transducers (see [6.9](#)).

NOTE 3 Best practice would suggest probing the bore C as a cylinder, intersecting the axis of the cylinder with plane A, and taking the point of intersection as the X- and Y-axis datum.

- 5) Use plane A to set the WCS Z-axis datum point.
- b) Phase 2: WCS position and orientation verification.
- 1) Acquire and record the Z-axis coordinates ( $Z_{PLA}$ ) of four points by probing plane A in the Z-axis direction at the following coordinates: X-20,Y-20; X-20,Y20; X20,Y20; X20,Y-20 (points 1 to 4 in [Figure 6](#)).
  - 2) Acquire and record the Y-axis coordinates ( $Y_{LIN}$ ) of two points by probing the test artefact plane B in the Y-axis direction at coordinates: X-20, Z-10; X20, Z-10 (points 5 and 6 in [Figure 6](#)).
  - 3) Measure and record the X- and Y-axis coordinates ( $X_{BOR}$ ,  $Y_{BOR}$ ) of the bore C centre according to the probing system manufacturer's/supplier's instructions.
  - 4) Measure and record a corner X-, Y- and Z-axis coordinates ( $X_{COR}$ ,  $Y_{COR}$ ,  $Z_{COR}$ ) by probing a single point on each of the three D, B and A planes respectively (points 7, 6 and 4 in [Figure 6](#)).

#### 6.7.4 Analysis of results

Calculate the WCS reference plane identification error,  $E_{PLA,Z}$ , as the range of the recorded  $Z_{PLA}$  values.

NOTE  $E_{PLA,Z}$  includes reference plane flatness error.

Calculate the orientation of the WCS in the reference plane identification error,  $E_{LIN,Y}$ , as the difference between the recorded  $Y_{LIN}$  coordinate values.

Calculate the corner location errors,  $E_{COR,X}$ ,  $E_{COR,Y}$  and  $E_{COR,Z}$ , as the difference between the recorded  $X_{COR}$ ,  $Y_{COR}$ ,  $Z_{COR}$  corner coordinates and the corner coordinates known from previous measurement, e.g. CMM measurement.

#### 6.7.5 Alternative workpiece position and orientation test

##### 6.7.5.1 Test setup and procedure

The workpiece position and orientation test may also be performed using a standard gauge block with a calibrated length of approximately 50 mm (see [Figure 7](#)). This alternative test determines the WCS datum point on a corner of the gauge block. Therefore, it does not evaluate the corner location errors,  $E_{COR,X}$ ,  $E_{COR,Y}$  and  $E_{COR,Z}$ . Furthermore, there may be a difference in the error of identification of WCS X- and Y-axis datum point on the corner compared to the one corresponding to the WCS datum on the centre of the bore in the previous test (see [6.7.2](#)). This is due to the contribution of the effective stylus tip diameter error to the error of identification of the WCS datum point on the corner whereas such error contribution is minimized in the case of the WCS datum on the centre of the bore due to the selection of opposing probing points around the bore. Nevertheless, the effective stylus tip diameter error is derived from the measurement of the gauge block calibrated length and taken into account in determining the error of identification of the WCS datum point (see [6.7.5.2](#)).

Position the gauge block in a workpiece representative position within the machine tool measuring volume and mount it deliberately skewed by approximately  $1^\circ$  in three directions with respect to the MCS.

Some probing systems only offer an alignment capability in the XY plane. In such cases, the gauge block shall be mounted with its top surface parallel to the machine tool XY plane and one of its sides out of alignment with respect to the MCS by approximately  $1^\circ$ . In this case, step a) 1) of the following test procedure shall not be executed.

Workpiece features shall be identified by probing them with the number of points that corresponds to the probing system's intended use and applying the following procedure.

- a) Phase 1: WCS orientation and position identification.
  - 1) Set the WCS reference plane by probing the gauge block plane A (see [Figure 7](#)).

- 2) Set the orientation of the WCS in the reference plane by probing line L on the gauge block plane B, which is one of its lapped planes (see [Figure 7](#)).

NOTE 1 Best practice would suggest probing plane B as a plane, intersecting plane B with plane A and using the intersecting straight line as the orientation of the WCS in the reference plane A.

- 3) Set the WCS X-, Y- and Z-axis datum point at the front right top corner (see [Figure 7](#)), by probing a single point on each of the three D, B and A planes, respectively.
- 4) Set again the WCS X-, Y- and Z-axis datum point at the front right top corner.

NOTE 2 This repeated operation is needed to minimize the effect of time delay between probing signal and read-out of machine tool position transducers (see [6.9](#)).

NOTE 3 Best practice would suggest probing plane B and plane D by *n* points, intersecting planes A, B and D and using the intersection point as the WCS X-, Y- and Z-axis datum point.

b) Phase 2: WCS position and orientation verification.

- 1) Acquire and record the Z-axis coordinates,  $Z_{PLA}$ , of four points by probing plane A in the Z-axis direction at the following coordinates: X-5,Y5; X-30,Y5; X-30,Y45; X-5,Y45 (points 1 to 4 in [Figure 7](#)).
- 2) Acquire and record the Y-axis coordinates,  $Y_{LIN}$ , of two points by probing the gauge block plane B in the Y-axis direction at coordinates: X-30,Z-4; X-5,Z-4 (points 5 and 6 in [Figure 7](#)).
- 3) Measure and record the front right top corner X-, Y- and Z-axis coordinates,  $X_{COR}$ ,  $Y_{COR}$ ,  $Z_{COR}$ , by probing a single point on each of the three A, B and D planes respectively (points 7, 6 and 1 in [Figure 7](#)).
- 4) Measure the gauge block calibrated size,  $S_Y$ , using the probing system built-in cycle.

Dimensions in millimetres

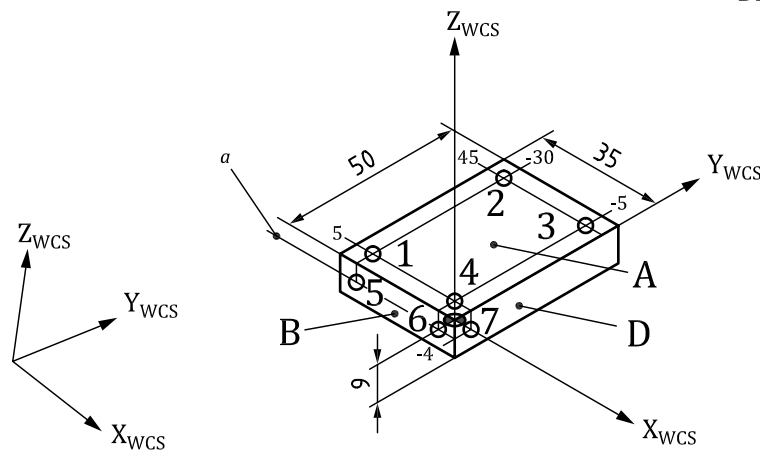

**Key**

- A plane A
- B plane B
- D plane D
- a Line L.

1 to 7 measuring points for WCS position and orientation verification

**Figure 7 — Alternative WCS position and orientation test using a gauge block**



### 6.7.5.2 Analysis of results

Calculate the WCS reference plane identification error,  $E_{PLA,Z}$ , as the range of the recorded  $Z_{PLA}$  values.

NOTE  $E_{PLA,Z}$  includes reference plane flatness error.

Calculate the orientation of WCS in the reference plane identification error,  $E_{LIN,Y}$ , as the difference between the recorded  $Y_{LIN}$  coordinate values.

Calculate the effective stylus tip diameter error,  $E_{EST,Y}$ , as the differences between the recorded  $S_Y$  value and the gauge block calibrated length.

Half of the  $E_{EST,Y}$  value can be estimated to be the additional contribution to the error of identification of the WCS datum point of the X- and Y-axes.

The corner location errors,  $E_{COR,X}$ ,  $E_{COR,Y}$  and  $E_{COR,Z}$ , are reported as the recorded  $X_{COR}$ ,  $Y_{COR}$ ,  $Z_{COR}$  corner coordinates.

## 6.8 Combined workpiece machining and location test, $E_{CML,X}$ , $E_{CML,Y}$ , $E_{CML,Z}$ , $R_{CML,X}$ , $R_{CML,Y}$ and $R_{CML,Z}$ ( $E$ Combined Machining and Location, X,Y,Z), ( $R$ Combined Machining and Location, X,Y,Z)

### 6.8.1 General

For some applications, workpiece position and orientation are measured to identify previously machined elements on the workpiece, in order to refer subsequent machining operations to them.

A practical test to compare actual machining to actual measurement requires machining a bore and an upper face on a test part and their measurement with the probing system: the measured bore centre X- and Y-axis coordinates should correspond to the programmed bore centre coordinates and the measured upper face Z-axis coordinate should correspond to the programmed Z-axis coordinate.

It shall be considered that such a test is additionally influenced by

- machined surface finish,
- milling tool length setting,
- probing-tool length setting, and
- machine thermal drift (e.g. spindle thermal drift).

### 6.8.2 Test setup and procedure

a) Phase 1: machining.

- 1) Rigidly mount a test part of at least 25 mm in thickness to the machine table in preparation for machining. The part material shall be agreed on between manufacturer/supplier and user or shall represent intended use.
- 2) A high-quality bore of approximately 25 mm in diameter shall be machined with a surface finish better than the probing system repeatability specification. A pre-drilling of a hole 1,25 mm undersized, followed by a pre-boring 0,2 mm undersized is recommended.
- 3) Face the part with an appropriate facing tool, either over its complete surface or at a spot, with a surface finish better than the probing system repeatability specification.

b) Phase 2: testing.

- 1) Mount the pre-qualified probing tool on the spindle.
- 2) Measure the bore centre using the manufacturer/supplier-recommended measuring cycle and record the X- and Y-axis bore centre coordinates,  $X_{BOR}$  and  $Y_{BOR}$ .

- 3) Measure the faced surface using the measuring cycle recommended by the manufacturer/supplier and record the milled surface Z-axis coordinate,  $Z_{PLA}$ .
- 4) Perform the standard probing-tool change procedure and repeat this testing procedure nine times starting from item b) 2) to acquire a total of ten sets of  $X_{BOR}$ ,  $Y_{BOR}$  and  $Z_{PLA}$  measured coordinates.

If intended use foresees the use of an automatic tool changer, before the probe is returned to the spindle, the tool changer should be indexed at least one position and returned in order to include the repeatability of this system.

In some high-speed milling applications, the tool holder is not provided with driving dogs. In such applications, the relative angular position between the spindle and the probing tool is not controlled. It is therefore recommended to complement this item by subsequently incrementing the relative probing-tool angular position by approximately 15°.

### 6.8.3 Analysis of results

Calculate the combined X-axis machining and location error,  $E_{CML,X}$ , by subtracting the average of the recorded  $X_{BOR}$  coordinates to the programmed bore coordinate.

Calculate the combined X-axis machining and location repeatability,  $R_{CML,X}$ , as the range of the recorded  $X_{BOR}$  coordinates.

Calculate the combined Y-axis machining and location error,  $E_{CML,Y}$ , by subtracting the average of the recorded  $Y_{BOR}$  coordinates to the programmed bore coordinate.

Calculate the combined Y-axis machining and location repeatability,  $R_{CML,Y}$ , as the range of the recorded  $Y_{BOR}$  coordinates.

Calculate the combined Z-axis machining and location error,  $E_{CML,Z}$ , by subtracting the average of the recorded  $Z_{PLA}$  coordinates to the programmed coordinate.

Calculate the combined Z-axis machining and location repeatability,  $R_{CML,Z}$ , as the range of the recorded  $Z_{PLA}$  coordinates.

## 6.9 Time delay variation tests

### 6.9.1 General

Probing systems for machine tools are expected to be sensitive to stylus tip deflection resulting from a surface contact and, at the same time, insensitive to stylus tip deflection resulting from machine tool vibration. These conflicting functional specifications are dealt with in different ways depending on probe-specific switching technology (electrical circuit breakage, strain gauge, etc.) and depending on specific probing system designs. Decreasing the sensitivity to vibration is sometimes achieved by applying “damping” strategies to probe signal conditioning electronics and/or logical processing of the probe signal by the machine tool CNC. Some CNC architectures employ very fast hardware registers to store the machine tool position transducer read-out whereas other CNC architectures acquire such data within the programmable logic controller (PLC) control loop cycle.

NOTE 1 For a constant probing feed speed of 480 mm/min, for example, the stylus tip moves 0,008 mm/ms, so a 5 ms delay would correspond to 0,040 mm. The time delay is accounted for in the determination of probing system effective stylus tip diameter during qualification but its variation is not accounted for.

NOTE 2 Although the main concern is time delay variation, attention is drawn to the fact that even constant time delays can cause probing errors if probing feed speed during measurement is different from the feed speed applied during probe qualification.

In principle, as the position of the workpiece feature that shall be measured is unknown, the actual approaching distance during probing is also unknown. Time delays may vary as a function of the



approaching distance because the actual stylus tip position is under CNC control, but time delay can be an unknown variable.

Different interactions between the CNC, PLC and probing system might lead to different time delays that, in turn, might significantly reduce the probing system overall performance.

NOTE 3 As the position of the workpiece feature being measured is unknown, the approaching direction applied for circle and sphere measurement is not exactly normal to the surface being measured (detected); thus time delay variation test results also include possible residual errors resulting from the effective stylus tip diameter compensation strategy applied by the probing system software.

The tests described in this clause are needed only for general performance characterization of particular probing systems and do not necessarily need to be repeated during probing system performance reverification tests unless the measurement feed speed is changed.

### 6.9.2 Time delay variation test for individual axes, $E_{SPT,TD,X}$ , $E_{SPT,TD,Y}$ , $E_{SPT,TD,Z}$ ( $E_{\text{Single-Point, Time Delay variation, X,Y,Z}}$ )

#### 6.9.2.1 Test setup and procedure

- a) Position the gauge block described in 6.7.5, Figure 7, and align it to the MCS in order to orient the three planes square to the X-, Y- and Z-axes, respectively.
- b) Set the WCS X-, Y- and Z-axis datum point at the front right-hand top corner (see Figure 7) by probing a single point on each of the three D, B and A planes, respectively.
- c) Sequentially position the machine axes to X5, Y5 and Z-4 (in front of point 7 in Figure 7).
- d) Acquire and record the  $X_{SPT,TD}$  coordinate value by probing a single point in the X-negative direction.
- e) Position the machine axis, incrementing the previous X-axis position by 0,010 mm (e.g. at the first repetition, the X-axis shall be positioned at X5, 010).
- f) Repeat the procedure starting from item d) in order to acquire and record a total of ten  $X_{SPT,TD}$  coordinate values.
- g) Sequentially position the machine axes to Y-5, Z-4 and X-5 (in front of point 6 in Figure 7).
- h) Acquire and record the  $Y_{SPT,TD}$  coordinate value by probing a single point in the Y-positive direction.
- i) Position the machine axis, decrementing the previous Y-axis position by 0,010 mm (e.g. at the first repetition, the Y-axis shall be positioned at Y-5, 010).
- j) Repeat the procedure, starting from item h) in order to acquire and record a total of ten  $Y_{SPT,TD}$  coordinate values.
- k) Sequentially position the machine axes to Z5, X-5 and Y5 (in front of point 4 in Figure 7).
- l) Acquire and record the  $Z_{SPT,TD}$  coordinate value by probing a single point in the Z-negative direction.
- m) Position the machine axis, incrementing the previous Z-axis position by 0,010 mm (e.g. at the first repetition, the Z-axis shall be positioned at Z5, 010).
- n) Repeat the procedure, starting from item l) in order to acquire and record a total of ten  $Z_{SPT,TD}$  coordinate values.

#### 6.9.2.2 Analysis of results

Calculate the single axis time delay variation error,  $E_{SPT,TD,X}$ , as the range of the measured  $X_{SPT,TD}$  values.

NOTE 1  $R_{SPT,X}$  repeatability for single-point surface measurement tested in 6.2.2 is included in  $E_{SPT,TD,X}$ .

Calculate the single axis time delay variation error,  $E_{SPT,TD,Y}$ , as the range of the measured  $Y_{SPT,TD}$  values.

NOTE 2  $R_{SPT,Y}$  repeatability for single-point surface measurement tested in 6.2.2 is included in  $E_{SPT,TD,Y}$ .

Calculate the single axis time delay variation error  $E_{SPT,TD,Z}$  as the range of the measured  $Z_{SPT,TD}$  values.

NOTE 3  $R_{SPT,Z}$  repeatability for single-point surface measurement tested in 6.2.2 is included in  $E_{SPT,TD,Z}$ .

**6.9.3 Time delay variation test for XY plane circle measurement,  $E_{CIR,TD,X}$ ,  $E_{CIR,TD,Y}$ ,  $E_{CIR,TD,D}$  and  $E_{CIR,TD,F}$  ( $E_{CIRcle}$ , Time Delay variation, X,Y), ( $E_{CIRcle}$ , Time Delay variation, Diameter) and ( $E_{CIRcle}$ , Time Delay variation, Form)**

#### 6.9.3.1 General

This test determines the ability of the probing system to measure the correct diameter and position of a circle when the measurement tool path is not exactly aligned with the circle. This test applies to typical probing systems that can measure a full circular artefact in the XY plane.

In advanced systems that are able to calculate circle features from 36 points, such as diameter, centre, and form error,  $F$ , it is recommended that this test be performed using 36 points as defined in the 2D probing error test,  $P_{FTU,2D}$  (see 6.5). This test is particularly useful for indicating the system 2D performance where the feature location is unknown (e.g. when locating a part).

#### 6.9.3.2 Test setup and procedure

- a) Set up a reference ring with a bore diameter of approximately 25 mm, calibrated for diameter and form, and align it to the MCS in order that the axis of the ring bore is parallel to the Z-axis of the machine.
- b) Measure the centre coordinates of the reference ring bore by probing it with four points. Establish a WCS datum point at the measured centre.
- c) Measure and record the centre coordinates,  $X_{CIR,TD}$  and  $Y_{CIR,TD}$ , of the reference ring and its diameter,  $D$ , and (for tests using 36 probing points) its form error,  $F$ .
- d) Repeat item c) nine times, adjusting the nominal position of the reference ring according to Table 2. The ring itself is not moved, but the new probing path for the bore measurement is generated assuming that the ring is located at the new offset position.

#### 6.9.3.3 Analysis of results

All calculations shall include the reference measurement results.

Calculate the X-axis time delay variation error  $E_{CIR,TD,X}$  for circle centre location as the range of the measured  $X_{CIR,TD}$  values.

NOTE 1  $R_{CIR,X}$  repeatability for circle centre location tested in 6.2.3 is included in  $E_{CIR,TD,X}$ .

Calculate the Y-axis time delay variation error  $E_{CIR,TD,Y}$  for circle centre location as the range of the measured  $Y_{CIR,TD}$  values.

NOTE 2  $R_{CIR,Y}$  repeatability for circle centre location tested in 6.2.3 is included in  $E_{CIR,TD,Y}$ .

Calculate the time delay variation error,  $E_{CIR,TD,D}$ , for diameter measurement as the range of the measured  $D$  values.

NOTE 3  $R_{CIR,D}$  repeatability for the circle diameter measurement tested in 6.10.3 is included in  $E_{CIR,TD,D}$ .

For tests using 36 probing points, calculate the time delay variation error,  $E_{CIR,TD,F}$  for circle form error measurement as the range of the measured form values,  $F$ , and also report  $E_{CIR,TD,F,MAX}$  as the maximum measured  $F$  value.

NOTE 4 The  $P_{FTU,2D}$  2D probing error tested in 6.5.3 is included in  $E_{CIR,TD,F,MAX}$ .

**Table 2 — X- and Y-axis offsets for time delay variation test for XY plane circle measurement**

Measurement number	Nominal centre coordinates with respect to the coordinates of the reference position		
	mm		
	X	Y	Z
1	0,000	0,300	0,000
2	0,193	0,230	0,000
3	0,295	0,052	0,000
4	0,260	-0,150	0,000
5	0,103	-0,282	0,000
6	-0,103	-0,282	0,000
7	-0,260	-0,150	0,000
8	-0,295	0,052	0,000
9	-0,193	0,230	0,000

NOTE Nominal centre positions in this table represent a spacing pattern, on the XY plane, of a circle of 0,3 mm radius with 40° increments.

**6.9.4 Time delay variation test for sphere measurement,  $E_{SPH,TD,X}$ ,  $E_{SPH,TD,Y}$ ,  $E_{SPH,TD,Z}$ ,  $E_{SPH,TD,D}$  and  $E_{SPH,TD,F}$  ( $E_{SPH,TD,F}$  (Time Delay variation, X,Y,Z), ( $E_{SPH,TD,D}$  (Time Delay variation, Diameter) and ( $E_{SPH,TD,F}$  (Time Delay variation, Form))**

#### 6.9.4.1 General

This test determines the ability of the probing system to calculate the correct diameter and position of a sphere when the measurement tool path is not exactly aligned with the feature. This test applies to typical probing systems that can measure a sphere.

In advanced systems that are able to calculate sphere features from 25 points such as centre, diameter and form error,  $F$ , it is recommended that this test be performed using 25 points as defined in the 3D probing error test,  $P_{FTU,3D}$  (see 6.6). This test is particularly useful for indicating the system 3D performance where the feature location is unknown (e.g. when locating a part).

#### 6.9.4.2 Test setup and procedure

- Position a reference sphere of approximately 25 mm in diameter, calibrated for diameter and form, in a workpiece representative position within the machine tool measuring volume.
- Measure the centre coordinates of the reference sphere by probing it with five points. Establish a WCS datum point at the measured centre of the reference sphere.
- Measure and record the centre coordinates,  $X_{SPH,TD}$ ,  $Y_{SPH,TD}$  and  $Z_{SPH,TD}$ , of the sphere and its diameter,  $D$ , and (for tests using 25 probing points) its form error,  $F$ .
- Repeat item c) nine times, adjusting the nominal position of the feature according to Table 3. The sphere itself shall not be moved, but the new probing path for the feature measurement is generated assuming that the sphere is located at the new offset position.

**6.9.4.3 Analysis of results**

All calculations shall include the reference measurement results.

Calculate the X-axis time delay variation error,  $E_{SPH,TD,X}$ , for sphere centre location as the range of the measured  $X_{SPH,TD}$  values.

NOTE 1  $R_{SPH,X}$  repeatability for sphere centre location tested in 6.2.4 is included in  $E_{SPH,TD,X}$ .

Calculate the Y-axis time delay variation error,  $E_{SPH,TD,Y}$ , for sphere centre location as the range of the measured  $Y_{SPH,TD}$  values.

NOTE 2  $R_{SPH,Y}$  repeatability for sphere centre location tested in 6.2.4 is included in  $E_{SPH,TD,Y}$ .

Calculate the Z-axis time delay variation error,  $E_{SPH,TD,Z}$ , for sphere centre location as the range of the measured  $Z_{SPH,TD}$  values.

NOTE 3  $R_{SPH,Z}$  repeatability for sphere centre location tested in 6.2.4 is included in  $E_{SPH,TD,Z}$ .

Calculate the time delay variation error,  $E_{SPH,TD,D}$ , for sphere diameter measurement as the range of the measured  $D$  values.

NOTE 4  $R_{SPH,D}$  repeatability for sphere diameter measurement tested in 6.10.4 is included in  $E_{SPH,TD,D}$ .

For tests using 25 probing points, calculate the time delay variation error,  $E_{SPH,TD,F}$ , for sphere form error measurement as the range of the measured form values  $F$  and also report  $E_{SPH,TD,F,MAX}$  as the maximum measured  $F$  value.

NOTE 5 The  $P_{FTU,3D}$  3D probing error tested in 6.6.3 is included in  $E_{SPH,TD,F,MAX}$ .

**Table 3 — X-, Y- and Z-axis offsets for time delay variation test for sphere measurement**

Measurement number	Nominal centre coordinates with respect to the coordinates of the reference position		
	mm		
	X	Y	Z
1	0,000	0,300	-0,150
2	0,260	-0,150	-0,150
3	-0,260	-0,150	-0,150
4	0,193	0,230	0,000
5	0,103	-0,282	0,000
6	-0,295	0,052	0,000
7	0,295	0,052	0,150
8	0,103	-0,282	0,150
9	-0,193	0,230	0,150

NOTE Nominal centre positions in this table represent a 0,3 mm radius circular pattern in the XY plane with 40° increments. This consists of three groups of three points, each at a different Z height, and with 120° increments in the XY plane.

**6.10 Feature size measurement performance tests**

**6.10.1 General**

Typical probing systems offer simplified measurement of distance between two (flat and parallel) surfaces (e.g. webs, slots and steps), circle diameter (e.g. bore and bosses) and sphere diameter. The results of these measurements are compared to the calibrated size of reference artefacts deliberately selected to have dimensions smaller than 60 mm in order to test the probing system performances in

a small, limited machine tool volume. This comparison provides limited size measurement traceability that should not be extrapolated to assume traceability for size measurement of workpiece features with different sizes.

NOTE 1 Measurements for distance between two flat and parallel surfaces and measurement for circle and sphere diameters are strongly influenced by the effective stylus tip diameter determined by probing system qualification.

NOTE 2 Measurements performed at different locations within the machine tool measuring volume might produce different results, e.g. due to geometric errors of the machine tool.

## 6.10.2 Web size measurement performance test, $E_{WEB,X}$ , $E_{WEB,Y}$ , $R_{WEB,X}$ and $R_{WEB,Y}$

### 6.10.2.1 General

Measuring the size of a web or pocket by probing two points on opposed surfaces is an extremely simplified operation that (strictly) only determines the distance between the two probed points.

### 6.10.2.2 Test setup and procedure

- a) Locate a reference gauge block with a size of approximately 50 mm, within the machine tool measuring volume, and align its reference faces to the MCS YZ plane.
- b) Measure and record the gauge block length,  $S_X$ , ten times using the probing system built-in cycle
- c) Align the gauge block reference faces to the MCS ZX plane.
- d) Measure and record the gauge block length,  $S_Y$ , ten times using the probing system built-in cycle.

### 6.10.2.3 Analysis of results

Compute the error for web size measurement along the X-axis,  $E_{WEB,X}$ , as the average of the differences between the recorded  $S_X$  values and the gauge-block calibrated length.

Compute the repeatability for web size measurement along the X-axis,  $R_{WEB,X}$ , as the range of the recorded  $S_X$  values.

Compute the error for web size measurement along the Y-axis,  $E_{WEB,Y}$ , as the average of the differences between the recorded  $S_Y$  values and the gauge-block calibrated length.

Compute the repeatability for web size measurement along the Y-axis,  $R_{WEB,Y}$ , as the range of the recorded  $S_Y$  values.

## 6.10.3 Circle diameter measurement performance test, $E_{CIR,D}$ and $R_{CIR,D}$ ( $E_{CIRcle, Diameter}$ ) and ( $R_{CIRcle, Diameter}$ )

### 6.10.3.1 General

Typical probing systems offer the capability to measure a circle by three or four points. Measurement of a circle by three points is a non-preferred method because the (possible) presence of contamination on the probed surface strongly influences the centre location and diameter measurements.

The number of points selected for the execution of this test shall be in accordance with the manufacturer's/supplier's instructions, but intended use shall be considered.

### 6.10.3.2 Test setup and procedure

- a) Set up a reference ring with a bore diameter of approximately 25 mm, calibrated for diameter and form, and align it to the MCS in order that the axis of the ring bore is parallel to the Z-axis of the machine.



- b) Measure the centre coordinates of the reference ring bore once. Establish a WCS datum point at the measured centre of the reference ring.
- c) Measure and record the ring diameter,  $D$ , ten times, probing it with the selected number of points.

#### 6.10.3.3 Analysis of results

Compute the error for circle diameter measurement,  $E_{CIR,D}$ , as the average of the differences between the recorded  $D$  values and the reference ring calibrated diameter.

Compute the repeatability for circle diameter measurement,  $R_{CIR,D}$ , as the range of the recorded  $D$  values.

#### 6.10.4 Sphere diameter measurement performance test, $E_{SPH,D}$ and $R_{SPH,D}$ ( $E_{SPH, \text{Diameter}}$ and $R_{SPH, \text{Diameter}}$ )

##### 6.10.4.1 General

Typical probing systems offer the capability to measure a sphere by four or five points. Measurement of a sphere by four points is a non-preferred method because the (possible) presence of contamination on the probed surface strongly influences the centre location and diameter measurements.

The number of points that shall be selected for the execution of this test shall be in accordance with the manufacturer's/supplier's instructions, but intended use shall be considered.

##### 6.10.4.2 Test setup and procedure

- a) Position a reference sphere of approximately 25 mm in diameter, calibrated for size and form, in a workpiece representative position within the machine tool measuring volume.
- b) Measure the centre coordinates of the reference sphere once. Establish a WCS datum point at the measured centre of the reference sphere.
- c) Measure and record the sphere diameter,  $D$ , ten times, probing it with the selected number of points.

##### 6.10.4.3 Analysis of results

Compute the error for sphere diameter measurement,  $E_{SPH,D}$ , as the average of the differences between the recorded  $D$  values and the reference sphere calibrated diameter.

Compute the repeatability for sphere diameter measurement,  $R_{SPH,D}$ , as the range of the recorded  $D$  values.

## 7 Probing of tools

### 7.1 General

Some machine tools are equipped with a sensor/probe system designed to set, under machine control, the length and/or diameter of a variety of rotating tools. Such tool setting systems are also sometimes used to reference the X-, Y- and Z-position of a non-rotating, geometrically accurate tool (e.g. a solid cylinder) or to detect broken tools.

In machining centre applications, tool setting systems are typically located near the edges of the machine working volume (or near the tool changer) and they are rigidly mounted in order to minimize deflection when submitted to typical switching forces of some newtons.

NOTE Some special-purpose tool-setting systems used for length setting of very small diameter tools have very limited switching forces.

Typical styli of tool-setting systems have a cylindrical or prismatic shape (see [Figure 8](#)) and their surface is wear-resistant.

Alignment of the stylus tip, which consists of aligning the stylus tip reference surfaces to the MCS, shall be performed in accordance with the manufacturer's/supplier's instructions.

Operation of the tool-setting system shall strictly conform to the manufacturer's/supplier's instructions. Additional attention shall be devoted to safety during measurement with rotating tools.

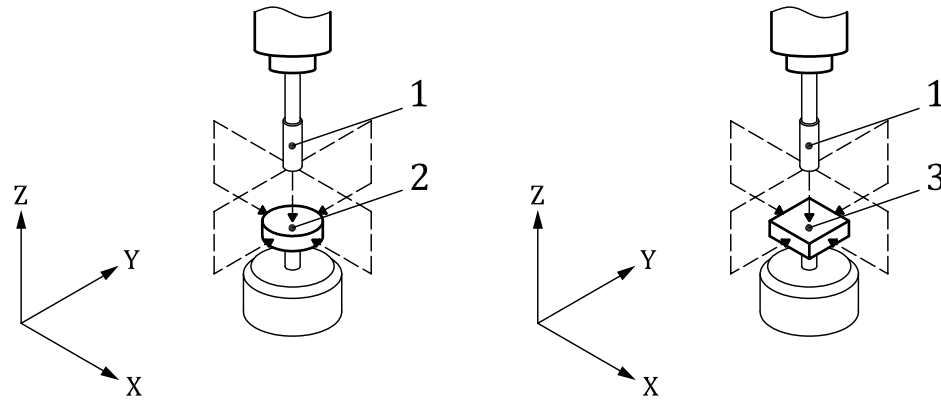

a) Tool-setting system with cylindrical shape

b) Tool-setting system with prismatic shape

#### Key

- 1 reference tool
- 2 disk type stylus tip
- 3 square type stylus tip
- machine tool movements

**Figure 8 — Sample qualification cycles for tool-setting system using a reference tool**

## 7.2 Tool-setting system qualification

Qualification of tool-setting systems is normally performed using a reference artefact representing the cutting tool (e.g. a solid cylinder, calibrated for diameter and length) applying an automatic built-in cycle aimed at defining

- a) stylus tip effective size, and
- b) stylus tip location with respect to the MCS.

Special care shall be devoted to the determination of the effective distance between the tool-setting system stylus and the spindle reference surface, as specified by the manufacturer's/supplier's instructions.

To determine such distance, an independent calibration of the length of the reference tool is required. This operation is indispensable to ensure tool-length setting performance and it is typically executed either by using an external tool-setting equipment or by measuring (directly on the machine tool) the distance between the spindle reference surface and the most protruding part of the reference tool with the help of a linear displacement sensor, taking the Z-axis displayed movement as the reference.

## 7.3 Tool-setting repeatability

### 7.3.1 General

Some tool-setting systems can only measure tool length without the spindle rotating. Others are capable of measuring length and diameter with the spindle rotating.

Some machines have a manual or robotic system to move the tool probe into the machine workspace. When testing these machines, after each tool measurement, the tool probe should be removed and moved again into the machine workspace.

The typical application of a properly qualified tool-setting system is relative measurement; therefore, only repeatability tests are addressed.

**7.3.2 Tool length-setting repeatability with a non-rotating tool,  $R_{SET,L,N}$  ( $R_{SETting,Length,Non-rotating}$ )**

**7.3.2.1 General**

Tool-length setting with a non-rotating tool is typically performed for drilling tools or for tools with a diameter smaller than the stylus diameter, thus ensuring that the longest tooth is detected.

Some systems also allow tool-length setting for non-rotating tools with large diameter where, with the help of spindle axis orientation, the most protruding cutter length is detected. See the manufacturer’s/supplier’s instructions.

**7.3.2.2 Test setup and procedure**

Position the spindle axis over the sensor/probe, programming (where applicable) the required offset (see [Figure 9](#)).

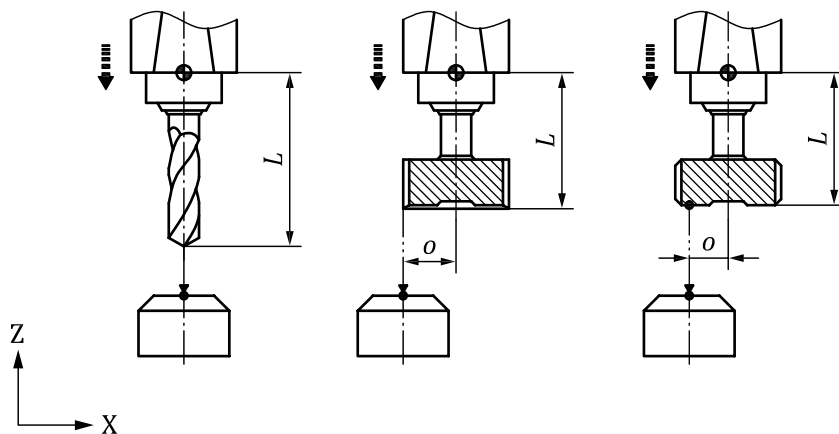

- Key**
- $L$  tool length
  - $o$  spindle axis offset

**Figure 9 — Tool-length setting repeatability measurement with a non-rotating tool**

Measure and record the tool-length,  $L$ , ten times using the cycle provided by the manufacturer/supplier. The spindle shall not be rotating.

Compute the tool-length setting repeatability,  $R_{SET,L,N}$ , as the range of the recorded  $L$  values.

**7.3.3 Tool length-setting repeatability of a rotating tool,  $R_{SET,L,R}$  ( $R_{SETting,Length,Rotating}$ )**

Tool-length measurement with a rotating tool may be performed for drills or ball end mills where the tangential speed of the rotating tool point contacting the probe/sensor is very small, or it may be performed for other types of tools by limiting the rotational speed and the feed speed in strict conformance with the manufacturer’s/supplier’s instructions (see [Figure 10](#)).

Tool rotation shall be in the opposite direction to normal cutting rotation.



**SAFETY PRECAUTIONS — Measurements with rotating tool involve safety issues. Attention should be paid to relevant safety standards.**

Measure and record the tool length,  $L$ , ten times, using the cycle provided by the manufacturer/supplier.

Compute the tool-length setting repeatability,  $R_{SET,L,R}$ , as the range of the recorded  $L$  values.

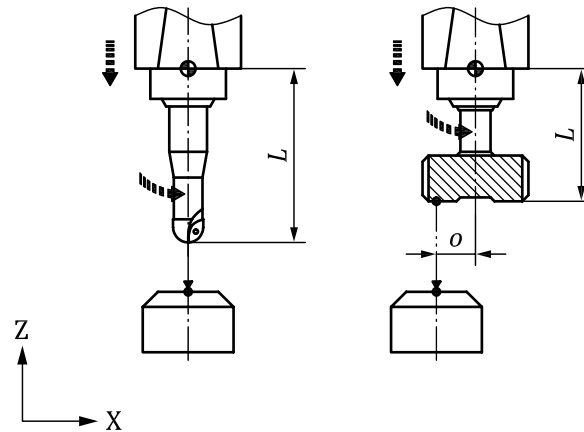

**Key**

- $L$  tool length
- $o$  spindle axis offset

**Figure 10 — Measurement of tool length-setting repeatability of a rotating tool**

**7.3.4 Tool diameter setting repeatability,  $R_{SET,D,R}$  ( $R_{SETting,Diameter,Rotating}$ )**

Tool rotation shall be in the opposite direction to normal cutting rotation. Measurement shall be performed in accordance with the manufacturer's/supplier's instructions (see [Figure 11](#)).

**SAFETY PRECAUTIONS — Measurements with rotating tool involve safety issues. Attention should be paid to relevant safety standards.**

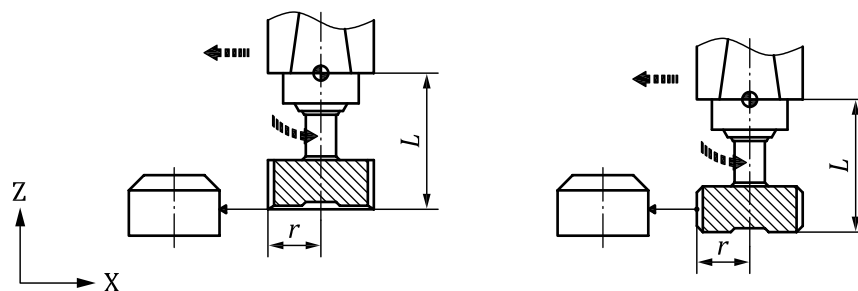

**Key**

- $L$  tool length
- $r$  tool radius

**Figure 11 — Measurement of tool diameter setting repeatability of a rotating tool**

Some tool-setting systems do not automatically control spindle speed and measuring feed speed to match the radius and the number of cutters of the tool. As safety issues are involved, additional attention is required and the following topics shall be considered:

- a) maximum tangential speed shall be defined by the manufacturer/supplier; an excessive tangential speed can deteriorate the performances of the probe/sensor;

- b) spindle speed for a given tool radius shall be automatically adapted (or programmed) according to item a);
- c) measurement feed speed shall be automatically adapted (or carefully selected) because the combination of non-synchronized angular location of the cutter with respect to the expected contacting point to the probe/sensor, approaching distance and feed speed would generate significant measurement uncertainty.

For a given maximum tangential speed  $S$ , the calculations in Formulae (2) and (3) shall be performed:

$$n = S / (2\pi \cdot r \cdot 0,001) \quad (2)$$

$$F = n \cdot \Delta \quad (3)$$

where

- $S$  is the tangential speed, in metres per minute;
- $r$  is the tool radius, in millimetres;
- $n$  is the calculated spindle speed, in rotations per minute;
- $F$  is the measurement feed speed, in millimetres per minute;
- $\Delta$  is the maximum expected measurement error, in millimetres.

The formulae refer to a single cutter tool. It shall be considered that, for multi-cutter tools, the single most protruding cutter has a higher probability of contacting the probe/sensor first; therefore, increasing the calculated feed speed in direct proportion to the number of cutters might underestimate the maximum expected measurement error.

**EXAMPLE** For a maximum tangential speed of 40 m/min and a single cutter tool with a radius of 40 mm, a maximum spindle speed of approximately 160 min<sup>-1</sup> is computed. For a maximum expected measurement error of 0,005 mm, a feed speed of 0,8 mm/min shall be programmed.

Position the Z-axis according to the manufacturer's/supplier's instructions for the specific tool type.

Measure and record the tool diameter ten times using the in-built cycle.

Compute the tool diameter setting repeatability,  $R_{SET,D,R}$ , as the range of the recorded values.

## Annex A (informative)

### Alphabetical cross-references and short description of symbols

**Table A1 — Alphabetical cross reference and short descriptions of symbols**

Symbol	Description	Subclause
<i>A</i>	Stylus tip offset	<a href="#">6.3</a>
<i>E<sub>CIR,D</sub></i>	Size error for circle diameter measurement	<a href="#">6.10.3</a>
<i>E<sub>CIR,TD,F</sub></i>	Range of measured circle form error for time delay variation test	<a href="#">6.9.3</a>
<i>E<sub>CIR,TD,F,MAX</sub></i>	Maximum measured circle form error for time delay variation test	<a href="#">6.9.3</a>
<i>E<sub>CIR,TD,D</sub></i>	Time delay variation error for the circle diameter measurement	<a href="#">6.9.3</a>
<i>E<sub>CIR,TD,X</sub></i>	X-axis circle centre location error for time delay variation test	<a href="#">6.9.3</a>
<i>E<sub>CIR,TD,Z</sub></i>	Y-axis circle centre location error for time delay variation test	<a href="#">6.9.3</a>
<i>E<sub>CML,X</sub></i>	X-axis combined machining and location error	<a href="#">6.8</a>
<i>E<sub>CML,Y</sub></i>	Y-axis combined machining and location error	<a href="#">6.8</a>
<i>E<sub>CML,Z</sub></i>	Z-axis combined machining and location error	<a href="#">6.8</a>
<i>E<sub>COR,X</sub></i>	X-axis error for corner location	<a href="#">6.7</a>
<i>E<sub>COR,Y</sub></i>	Y-axis error for corner location	<a href="#">6.7</a>
<i>E<sub>COR,Z</sub></i>	Z-axis error for corner location	<a href="#">6.7</a>
<i>E<sub>LIN,Y</sub></i>	WCS orientation in the reference plane identification error in the Y-axis direction	<a href="#">6.7</a>
<i>E<sub>SC,2D,DIA</sub></i>	Diameter error for 2D scanning test	<a href="#">B.6</a>
<i>E<sub>SC,2D,FORM</sub></i>	Form error for 2D scanning test	<a href="#">B.6</a>
<i>E<sub>SC,2D,POS</sub></i>	Positional reproducibility for 2D scanning test	<a href="#">B.6</a>
<i>E<sub>SC,3D,DIA</sub></i>	Diameter error for 3D scanning test	<a href="#">B.5</a>
<i>E<sub>SC,3D,POS</sub></i>	Positional reproducibility for 3D scanning test	<a href="#">B.5</a>
<i>E<sub>SC,3D,FORM</sub></i>	Form error for 3D scanning test	<a href="#">B.5</a>
<i>E<sub>SPH,D</sub></i>	Size error for sphere diameter measurement	<a href="#">6.10.4</a>
<i>E<sub>SPH,TD,F</sub></i>	Range of measured sphere form error for time delay variation test	<a href="#">6.9.4</a>
<i>E<sub>SPH,TD,F,MAX</sub></i>	Maximum measured sphere form error for time delay variation test	<a href="#">6.9.4</a>
<i>E<sub>SPH,TD,D</sub></i>	Error of sphere diameter measurement for time delay variation test	<a href="#">6.9.4</a>
<i>E<sub>SPH,TD,X</sub></i>	X-axis sphere centre location error for time delay variation test	<a href="#">6.9.4</a>
<i>E<sub>SPH,TD,Y</sub></i>	Y-axis sphere centre location error for time delay variation test	<a href="#">6.9.4</a>
<i>E<sub>SPH,TD,Z</sub></i>	Z-axis sphere centre location error for time delay variation test	<a href="#">6.9.4</a>
<i>E<sub>SPT,TD,X</sub></i>	X-axis error for single axis time delay variation test	<a href="#">6.9.2</a>
<i>E<sub>SPT,TD,Y</sub></i>	Y-axis error for single axis time delay variation test	<a href="#">6.9.2</a>
<i>E<sub>SPT,TD,Z</sub></i>	Z-axis error for single axis time delay variation test	<a href="#">6.9.2</a>
<i>E<sub>PLA,Z</sub></i>	WCS reference plane identification error in Z-axis direction	<a href="#">6.7</a>
<i>E<sub>WEB,X</sub></i>	Size error for web measurement in the X-axis direction	<a href="#">6.10.2</a>
<i>E<sub>WEB,Y</sub></i>	Size error for web measurement in the Y-axis direction	<a href="#">6.10.2</a>
<i>P<sub>FTU</sub></i>	Probing error definition	<a href="#">3.3.3</a>
<i>P<sub>FTU,2D</sub></i>	2D probing error	<a href="#">6.5</a>

Table A1 (continued)

Symbol	Description	Subclause
$P_{FTU,3D}$	3D probing error	<a href="#">6.6</a>
$R_{CIR,D}$	Repeatability of circle diameter measurement	<a href="#">6.10.3</a>
$R_{CIR,X}$	Repeatability of circle centre location in the X-axis direction	<a href="#">6.2.3</a>
$R_{CIR,Y}$	Repeatability of circle centre location in the Y-axis direction	<a href="#">6.2.3</a>
$R_{CML,X}$	X-axis combined machining and location repeatability	<a href="#">6.8</a>
$R_{CML,Y}$	Y-axis combined machining and location repeatability	<a href="#">6.8</a>
$R_{CML,Z}$	Z-axis combined machining and location repeatability	<a href="#">6.8</a>
$R_{PTL,X}$	Repeatability of probing-tool location in the X-axis direction	<a href="#">6.4</a>
$R_{PTL,Y}$	Repeatability of probing-tool location in the Y-axis direction	<a href="#">6.4</a>
$R_{PTL,Z}$	Repeatability of probing-tool location in the Z-axis direction	<a href="#">6.4</a>
$R_{SPH,X}$	Repeatability of sphere centre location in the X-axis direction	<a href="#">6.2.4</a>
$R_{SPH,Y}$	Repeatability of sphere centre location in the Y-axis direction	<a href="#">6.2.4</a>
$R_{SPH,Z}$	Repeatability of sphere centre location in the Z-axis direction	<a href="#">6.2.4</a>
$R_{SET,L,N}$	Tool-length setting repeatability with a non-rotating tool	<a href="#">7.3.2</a>
$R_{SET,L,R}$	Tool-length setting repeatability with a rotating tool	<a href="#">7.3.3</a>
$R_{SET,D,R}$	Tool diameter setting repeatability	<a href="#">7.3.4</a>
$R_{SPH,D}$	Repeatability of sphere diameter measurement	<a href="#">6.10.4</a>
$R_{SPT,X}$	Repeatability of single-point probing in the X-axis direction	<a href="#">6.2.2</a>
$R_{SPT,Y}$	Repeatability of single-point probing in the Y-axis direction	<a href="#">6.2.2</a>
$R_{SPT,Z}$	Repeatability of single-point probing in the Z-axis direction	<a href="#">6.2.2</a>
$R_{WEB,X}$	Repeatability of web size measurement in the X-axis direction	<a href="#">6.10.2</a>
$R_{WEB,Y}$	Repeatability of web size measurement in the Y-axis direction	<a href="#">6.10.2</a>
$T_{SC,2D}$	Time for 2D scanning test	<a href="#">B.6</a>
$T_{SC,3D}$	Time for 3D scanning test	<a href="#">B.5</a>

## Annex B (informative)

### Measuring performance with scanning probes

#### B.1 Introduction

This annex provides test procedures to evaluate the scanning performance of contacting probing systems, integrated with a numerically controlled machine tool, and used in a pre-defined path scanning mode (see [3.4.9](#)).

These tests are supplementary to the discrete point tests that are specified in [Clauses 6](#) and [7](#). Contacting probing systems that do not support discrete point measurement are not covered by this annex.

[Clauses 1](#) to [5](#) are applicable to this annex.

The test procedures are not intended to distinguish between the various causes of errors. They are intended to demonstrate the combined influence of the environment, machine tool, probing system and probing software on the measuring performance.

The tests in this annex are applicable to both acceptance testing and re-verification testing, and should be run periodically, after a crash of the probe or machine, or if any of the following probing conditions are changed:

- feed speed during measurement;
- stylus system (in particular stylus system length);
- feed speed during qualification;
- probing system orientation during measurement (e.g. vertical or horizontal orientation of probe);
- probe;
- nominal deflection;
- measurement range.

#### B.2 Terms and definitions

For the purpose of this annex, the terms and definitions given in [3.4](#) apply.

#### B.3 General considerations

Some sources of measurement error in continuous scanning systems on machine tools are different from those on a CMM. The main differences are as follows.

- A machine tool typically does not control probe deflection while scanning. This means that the positional uncertainty of the workpiece is more likely to affect measurement uncertainty on a machine tool.
- Machine tools are optimized for cutting, not measurement. Machine position reporting errors during qualification and subsequent measurements typically create differences between the measurement accuracy of inside and outside features, for example bores and bosses.

The following tests should be performed using the feed speed and the measurement range specified for the probing system or agreed between manufacturer/supplier and user.

The tests in this annex are sensitive to stylus configuration; especially stylus length and stylus tip diameter. For acceptance testing, the stylus configuration should be agreed between manufacturer/supplier and user. For verification testing, the tests should be run whenever a new stylus configuration is used.

For probing systems that control probe deflection using real-time feedback to adjust the measurement path, the less comprehensive but shorter test specified in ISO 10360-4 may be appropriate. For this type of system, if agreed between manufacturer/supplier and user, the scanning 3D performance test (see [B.5](#)) could be replaced by the test specified in ISO 10360-4. If this is done it is nevertheless recommended that the scanning 2D performance test (see [B.6](#)) is still performed.

NOTE The scanning 3D performance test contains the measurements required for ISO 10360-4. If required, the measurement data from the scanning 3D performance test can also be analysed to produce ISO 10360-4 results.

The 3D scanning performance test is performed on an external surface, whereas the 2D scanning performance test is performed on an internal surface. The two tests have been designed to be complementary to each other as scanning systems on machine tools can have significantly different uncertainties when scanning internal and external surfaces. It is recommended that both tests be performed.

The probe should be tool changed and, where applicable, the tool change indexer moved by at least one index position after qualification and between each test.

### B.4 Filtering parameters

The filtering algorithms and parameters used during these tests affect the results and should be agreed between manufacturer/supplier and user. They should be stated in the test report.

### B.5 Scanning 3D performance test, $E_{SC,3D,POS}$ , $E_{SC,3D,DIA}$ , $E_{SC,3D,FORM}$ , $T_{SC,3D}$ , ( $ERROR_{SCanning,3D,POSition}$ , $ERROR_{SCanning,3D,DIAMeter}$ , $ERROR_{SCanning,3D,FORM}$ and $Time_{SCanning,3D}$ )

#### B.5.1 General

This test determines the ability of the probing system to measure a test sphere when the measurement tool-path is not exactly aligned with the test sphere. This test applies to probing systems that can measure a sphere in continuous scanning mode, and simulates the deviation of workpiece position during in-process measurement.

The probe is operated over its full 3D measurement range in this test. This test does not include the effects of temperature variation on positional uncertainty. The user of a contact scanning system is advised to consider the effect of temperature variations on the measurement range requirements.

This test is designed to be run on three-axis machines, including machines that can only interpolate in XY, YZ and ZX planes. The test is specified assuming that the Z-axis of the probe is aligned with the Z-axis of the machine tool so that it is widely applicable.

The time for the test is recorded to give an indication of system speed, and because it may affect accuracy.

#### B.5.2 Sphere measurement sequence

See [Figure B.1](#).

- a) The coordinate system origin is at the centre of the sphere, and is aligned with the X-, Y- and Z-axes of the probe. The pole of the sphere is at  $X = 0$ ,  $Y = 0$ ,  $Z = r$  (radius of sphere).



b) The arrows on the diagram indicate the directions of travel along the target scan lines.

The direction and feed speed of the approach moves to the target scan lines should be in accordance with the manufacturer's/supplier's recommendations.

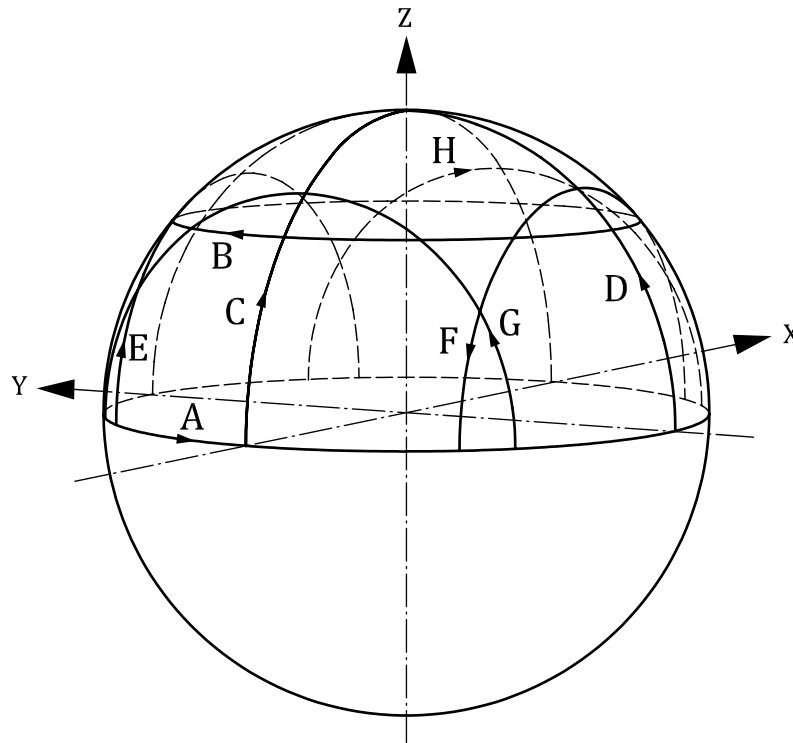

#### Key

- A target scan line A (CCW) is on the equator in the XY plane
- B target scan line B (CW) is parallel to the XY plane, 8 mm above the equator (diameter of sphere is 25 mm)
- C, D target scan lines C (CCW) and D (CW) are in the ZX and ZY planes respectively, and go through the pole
- E, F target scan lines E (CCW) and F (CW) are parallel to the ZX plane, at  $Y = +8$  mm and  $Y = -8$  mm, respectively
- G, H target scan lines G (CW) and H (CCW) are parallel to the ZY plane, at  $X = -8$  mm and  $X = +8$  mm respectively

**Figure B.1 — Target scan lines and required direction of travel for the scanning 3D performance test**

### B.5.3 Test set up and procedure

- a) Position a test sphere of approximately 25 mm diameter, calibrated for size and form, in a workpiece representative position within the machine tool measuring volume.
- b) The user is free to choose the location of the mounting of the test sphere within the specified measuring volume. However, it is recommended that the test sphere not be placed at the location used for the probing system qualification.
- c) The stylus tip and the reference/test sphere(s) should be cleaned before the probing system qualification so as to leave no residual contamination that could affect the measuring or test result.
- d) Ensure that the probing system has been qualified according to the manufacturer's/supplier's instructions.
- e) Measure the centre coordinates of the test sphere by probing it with five or more discrete points. Establish a WCS datum point at the measured centre of the test sphere.

- f) Use the sphere measurement sequence specified in B.5.2 to scan the sphere. The sphere should be scanned ten times setting the nominal position of the sphere according to the values in Table B.1.
- g) Record the time for the test  $T_{SC,3D}$  as the time taken to perform the test from the start of the first scan sequence of the first measurement (at the intermediate point) to the end of the last scan sequence of the last measurement (at the intermediate point).

NOTE The test sphere itself is not moved during this test; the scanning path for the sphere measurement is generated assuming that the test sphere is located at the specified nominal positions.

**Table B.1 — X-, Y-, and Z-axis offsets for the scanning 3D performance test**

Measurement number	Nominal centre position with respect to the reference position mm		
	X	Y	Z
1	0	0	0
2	0	$R_{XY}$	0
3	$R_{XY}$	0	0
4	$-R_{XY}$	0	0
5	0	$-R_{XY}$	0
6	0	0	$R_{ZPOS}$
7	0	0	$-R_{ZNEG}$
8	$R \times 0,683$	$R \times 0,183$	$R \times 0,707$
9	$R \times -0,500$	$R \times 0,500$	$R \times 0,707$
10	$R \times -0,183$	$R \times -0,683$	$R \times 0,707$

$R_{XY}$  is the XY-plane scanning measurement range as specified by the manufacturer/supplier.  
 $R_{ZPOS}$ , and  $R_{ZNEG}$  are the Z axis measurement range (positive and negative material condition respectively) as specified by the manufacturer/supplier.  
 $R$  is the smallest of  $R_{XY}$ ,  $R_{ZPOS}$ , and  $R_{ZNEG}$ .

**B.5.4 Analysis of results**

Filtering algorithms and parameters may be used for the analysis of the scanning 3D performance test as agreed between manufacturer/supplier and user. If filtering is applied, the parameters and algorithms used should be stated with the test results (see B.4).

For each sphere measurement, proceed as follows.

- Compute the centre location and diameter of the Gaussian (least squares) sphere (associated feature) using all of the tip centre points of all eight scans. Record these values as centre coordinates  $X_{SC,3D}$ ,  $Y_{SC,3D}$ ,  $Z_{SC,3D}$ , and the diameter  $D_{SC,3D}$  of the sphere.
- For each of the measured scan points, calculate the radial distance,  $r$ , to the centre coordinates of the sphere [according to item a)].
- Compute the scanning probing error,  $F_{SC,3D}$ , as the range of the calculated radial distances,  $r$ .

Using the above data, proceed as follows.

- a) Calculate the scanning 3D position reproducibility,  $E_{SC,3D,POS}$  as the maximum distance of any of the sphere centre locations  $X_{SC,3D}$ ,  $Y_{SC,3D}$ ,  $Z_{SC,3D}$  recorded in measurement 2 to 10 from the sphere centre location recorded in measurement 1.
- b) Calculate the scanning 3D diameter error  $E_{SC,3D,DIA}$  as the maximum deviation of any of the 10  $D_{SC,3D}$  measurements from the sum of the stylus tip diameter and the calibrated test sphere

diameter. If the scanning system can report the qualified diameter of the stylus tip, then this value should be used, otherwise the nominal diameter of the stylus tip should be used.

- c) Calculate the scanning 3D form error,  $E_{SC,3D,FORM}$  as the maximum of the form values  $F_{SC,3D}$  in any of the ten measurements.

NOTE The test sphere form error is included in the scanning 3D form error,  $E_{SC,3D,FORM}$ .

- d) Report the scanning 3D time  $T_{SC,3D}$ .

## **B.6 Scanning 2D performance test, $E_{SC,2D,POS}$ , $E_{SC,2D,DIA}$ , $E_{SC,2D,FORM}$ , $T_{SC,2D}$ (Error<sub>SCanning,2D,POSition</sub>, Error<sub>SCanning,2D,DIAMeter</sub>, Error<sub>SCanning,2D,FORM</sub> and Time<sub>SC,2D</sub>)**

### **B.6.1 General**

This test determines the ability of the probing system to calculate the diameter, position, and form of a reference ring when the measurement tool-path is not exactly aligned with the feature. This test applies to probing systems that can measure a reference ring, and simulates the deviation of workpiece position during in-process measurement.

The probe is operated over its full 2D measurement range in this test.

### **B.6.2 Reference ring measurement sequence**

The reference ring should be scanned using alternating clockwise and counter-clockwise circle measurements, e.g. the first scan is clockwise, the second is counter-clockwise, the third is clockwise, etc.

The direction and feed speed of the approach moves to the target scan lines should be in accordance with the manufacturer's/supplier's recommendations.

### **B.6.3 Test set up and procedure**

- a) Set up a reference ring, calibrated for size and form, with a bore diameter of approximately 30 mm and align it to the MCS in order that the axis of the ring bore is parallel to the Z-axis of the machine.
- b) The user is free to choose the location of the mounting of the reference ring within the specified measuring volume. However, it is recommended that the test ring not be placed at the location used for the probing system qualification.
- c) The stylus tip, the reference sphere, and the reference ring should be cleaned before the probing system qualification so as to leave no residual contamination which could affect the measuring or test result.
- d) Ensure that the probing system has been qualified according to the manufacturer's/supplier's instructions.
- e) Measure the centre coordinates of the reference ring by probing it with four or more discrete points. Establish a WCS datum point at the measured centre of the reference ring.
- f) Measure the reference ring nine times in continuous scanning mode, setting the nominal position of the feature according to [Table B.2](#).
- g) For each measurement, use the scanning system's built in results analysis for circle measurements, and record the centre coordinates  $X_{SC,2D}$ ,  $Y_{SC,2D}$ , its diameter  $D_{SC,2D}$  and its form  $F_{SC,2D}$ .
- h) Record the time for the test  $T_{SC,2D}$  as the time taken to perform the test from the start of the first scan sequence of the first measurement (at the intermediate point) to the end of the last scan sequence of the last measurement (at the intermediate point).

Table B.2 — X-, Y-, and Z-axis offsets for scanning 2D performance test

Measurement number	Nominal centre position with respect to the reference position mm		
	X	Y	Z
1	0,000	0,000	0
2	$R_{XY} \times 0,000$	$R_{XY} \times 1,000$	0
3	$R_{XY} \times 0,707$	$R_{XY} \times 0,707$	0
4	$R_{XY} \times 1,000$	$R_{XY} \times 0,000$	0
5	$R_{XY} \times 0,707$	$R_{XY} \times -0,707$	0
6	$R_{XY} \times 0,000$	$R_{XY} \times -1,000$	0
7	$R_{XY} \times -0,707$	$R_{XY} \times -0,707$	0
8	$R_{XY} \times -1,000$	$R_{XY} \times 0,000$	0
9	$R_{XY} \times -0,707$	$R_{XY} \times 0,707$	0

$R_{XY}$  is the XY-plane scanning measurement range as specified by the manufacturer/supplier.

NOTE The reference ring itself is not moved; the probing-path for the measurement is generated assuming that the feature is located at the specified nominal position.

#### B.6.4 Analysis of results

- Calculate the scanning 2D positional reproducibility error  $E_{SC,2D,POS}$  as the maximum distance of any of the reference ring centre locations recorded in measurements 2 to 9 from the centre location recorded in measurement 1.
- Calculate the scanning 2D diameter error  $E_{SC,2D,DIA}$  as the maximum deviation of any of the nine measurements from the calibrated reference ring diameter.
- Calculate the scanning 2D form error  $E_{SC,2D,FORM}$  as the maximum of the form values  $F_{SC,2D}$  in any of the nine measurements.

NOTE The test ring form error is included in the scanning 2D form error,  $E_{SC,2D,FORM}$ .

- Record the scanning time  $T_{SC,2D}$  value.

## Bibliography

- [1] ISO 1, *Geometrical Product Specifications (GPS) — Standard reference temperature for geometrical product specification and verification*
- [2] ISO 1101, *Geometrical product specifications (GPS) — Geometrical tolerancing — Tolerances of form, orientation, location and run-out*
- [3] ISO 10360-1:2000, *Geometrical Product Specifications (GPS) — Acceptance and reverification tests for coordinate measuring machines (CMM) — Part 1: Vocabulary*
- [4] ISO 10360-2, *Geometrical product specifications (GPS) — Acceptance and reverification tests for coordinate measuring machines (CMM) — Part 2: CMMs used for measuring linear dimensions*
- [5] ISO 10360-4, *Geometrical Product Specifications (GPS) — Acceptance and reverification tests for coordinate measuring machines (CMM) — Part 4: CMMs used in scanning measuring mode*
- [6] ISO 10791-1, *Test conditions for machining centres — Part 1: Geometric tests for machines with horizontal spindle (horizontal Z-axis)*
- [7] ISO/TS 23165, *Geometrical product specifications (GPS) — Guidelines for the evaluation of coordinate measuring machine (CMM) test uncertainty*
- [8] ISO 14253-1, *Geometrical product specifications (GPS) — Inspection by measurement of workpieces and measuring equipment — Part 1: Decision rules for proving conformity or nonconformity with specifications*
- [9] ISO 14253-2, *Geometrical product specifications (GPS) — Inspection by measurement of workpieces and measuring equipment — Part 2: Guidance for the estimation of uncertainty in GPS measurement, in calibration of measuring equipment and in product verification*
- [10] ASME B89.7.3.1-2001, *Guidelines for decision rules — Considering measurement uncertainty in determining conformance to specifications*
- [11] ASME B89.4.1-1997, *Methods for performance evaluation of Coordinate Measuring Machines*
- [12] ASME B5.54-2005, *Methods for Performance evaluation of Computer Numerically Controlled Machining Centers*
- [13] VDI/VDE 2617-1, *Accuracy of Coordinate Measuring Machines — Characteristics and their Checking — Generalities*
- [14] VDI/VDE 2617-3, *Accuracy of Coordinate Measuring Machines — Characteristics and their Checking — Characteristic Parameters and their Checking — Components of Measurement Deviation on the Machine*
- [15] ISO/TR 230-9, *Test code for machine tools — Part 9: Estimation of measurement uncertainty for machine tool tests according to series ISO 230, basic equations*

