

---

---

**Rolling bearings — Thrust bearings  
— Geometrical product specification  
(GPS) and tolerance values**

*Roulements — Butées — Spécification géométrique des produits  
(GPS) et valeurs de tolérance*



Reference number  
ISO 199:2014(E)

© ISO 2014



**COPYRIGHT PROTECTED DOCUMENT**

© ISO 2014

All rights reserved. Unless otherwise specified, no part of this publication may be reproduced or utilized otherwise in any form or by any means, electronic or mechanical, including photocopying, or posting on the internet or an intranet, without prior written permission. Permission can be requested from either ISO at the address below or ISO's member body in the country of the requester.

ISO copyright office  
Case postale 56 • CH-1211 Geneva 20  
Tel. + 41 22 749 01 11  
Fax + 41 22 749 09 47  
E-mail [copyright@iso.org](mailto:copyright@iso.org)  
Web [www.iso.org](http://www.iso.org)

Published in Switzerland

# Contents

	Page
<b>Foreword</b> .....	<b>iv</b>
<b>Introduction</b> .....	<b>v</b>
<b>1 Scope</b> .....	<b>1</b>
<b>2 Normative references</b> .....	<b>1</b>
<b>3 Terms and definitions</b> .....	<b>1</b>
<b>4 Symbols</b> .....	<b>1</b>
<b>5 Limit deviations and tolerance values</b> .....	<b>7</b>
5.1 General .....	7
5.2 Tolerance class Normal .....	8
5.3 Tolerance class 6 .....	10
5.4 Tolerance class 5 .....	12
5.5 Tolerance class 4 .....	14
<b>Annex A (informative) Symbols and terms as given in ISO 199:2005 in relationship to new descriptions given in this document</b> .....	<b>16</b>
<b>Annex B (informative) Example of drawing indications of characteristics with specification for thrust bearings</b> .....	<b>18</b>
<b>Annex C (informative) Illustration of ISO 1132-1[4] and ISO 14405-1 terms and definitions</b> .....	<b>20</b>
<b>Annex D (informative) Description with illustrations for specification modifiers of linear sizes</b> .....	<b>25</b>
<b>Bibliography</b> .....	<b>33</b>

## Foreword

ISO (the International Organization for Standardization) is a worldwide federation of national standards bodies (ISO member bodies). The work of preparing International Standards is normally carried out through ISO technical committees. Each member body interested in a subject for which a technical committee has been established has the right to be represented on that committee. International organizations, governmental and non-governmental, in liaison with ISO, also take part in the work. ISO collaborates closely with the International Electrotechnical Commission (IEC) on all matters of electrotechnical standardization.

The procedures used to develop this document and those intended for its further maintenance are described in the ISO/IEC Directives, Part 1. In particular the different approval criteria needed for the different types of ISO documents should be noted. This document was drafted in accordance with the editorial rules of the ISO/IEC Directives, Part 2 (see [www.iso.org/directives](http://www.iso.org/directives)).

Attention is drawn to the possibility that some of the elements of this document may be the subject of patent rights. ISO shall not be held responsible for identifying any or all such patent rights. Details of any patent rights identified during the development of the document will be in the Introduction and/or on the ISO list of patent declarations received (see [www.iso.org/patents](http://www.iso.org/patents)).

Any trade name used in this document is information given for the convenience of users and does not constitute an endorsement.

For an explanation on the meaning of ISO specific terms and expressions related to conformity assessment, as well as information about ISO's adherence to the WTO principles in the Technical Barriers to Trade (TBT) see the following URL: [Foreword - Supplementary information](#)

The committee responsible for this document is ISO/TC 4, *Rolling bearings*, Subcommittee SC 4, *Tolerances, tolerance definitions and symbols (including GPS)*.

This fourth edition cancels and replaces the third edition (ISO 199:2005), which has been technically revised.



## Introduction

This International Standard is a machine element geometry standard as defined in the geometrical product specification (GPS) system as presented in master plan of ISO/TR 14638.<sup>[10]</sup>

The fundamental rules of ISO/GPS given in ISO 8015<sup>[7]</sup> apply to this International Standard and the default decision rules given in ISO 14253-1<sup>[8]</sup> apply to the specifications made in accordance with this International Standard, unless otherwise indicated.

The connection between functional requirements, measuring technique and measuring uncertainty is always intended to be considered. The traditionally used measuring technique is described in ISO 1132-2.<sup>[5]</sup> For measurement uncertainty it is intended that ISO 14253-2<sup>[9]</sup> should be considered.



# Rolling bearings — Thrust bearings — Geometrical product specification (GPS) and tolerance values

## 1 Scope

This International Standard specifies dimensional characteristics, limit deviations from nominal values, and tolerance values to define the interface (except chamfers) of thrust rolling bearings. Nominal boundary dimensions are defined in ISO 104[1].

This International Standard is not applicable to certain thrust bearings (e.g. thrust needle roller bearings) or for particular fields of application (e.g. special thrust precision bearings). Tolerances for such bearings are given in the relevant International Standards.

Chamfer dimension limits are given in ISO 582[3].

## 2 Normative references

The following documents in whole or in part, are normatively referenced in this document and are indispensable for its application. For dated references, only the edition cited applies. For undated references, the latest edition of the referenced document (including any amendments) applies.

ISO 5593, *Rolling bearings — Vocabulary*

ISO 14405-1, *Geometrical product specifications (GPS) — Dimensional tolerancing — Part 1: Linear sizes*

ISO/TS 17863, *Geometrical product specification (GPS) — Geometrical tolerancing of moveable assemblies*

## 3 Terms and definitions

For the purposes of this document, the terms and definitions in ISO 5593, ISO 14405-1, and ISO/TS 17863 apply.

## 4 Symbols

To express that the ISO/GPS system, ISO 8015 [Z] is applied, the dimensional characteristics shall be included in the technical product documentation (for example on the drawing). The dimensional specifications, associated to these characteristics, are described in [Table 1](#) and [Figures 1](#) to [4](#).

Descriptions for symbols are in accordance with GPS terminology; relationships with traditional terms are described in [Annex A](#).

A tolerance value associated to a characteristic is symbolized by  $t$  followed by the symbol for characteristic, for example,  $t_{\Delta\text{dmp}}$ .

In this International Standard, the ISO default specification operator for size is in accordance with ISO 14405-1, i.e. the two-point size is valid. Some specification modifiers are described in [Annex D](#).





The detailed definitions for terms in ISO 14405-1 and traditional terms in ISO 1132-1[4] are not fully equal, for differences, see [Annex C](#).

Table 1 — Symbols for nominal sizes, characteristics and specification modifiers

Symbol for nominal size <sup>a</sup>	Symbol for characteristic <sup>a</sup>	GPS symbol and specification modifier <sup>b c</sup>	Description <sup>d</sup>	See Figure
<i>d</i>			Nominal bore diameter of shaft washer, single-direction bearing	1; 2
	$\Delta d_{mp}$	$\textcircled{LP} \textcircled{SD} ACS$	Deviation of a mid-range size (out of two-point sizes) of shaft washer bore diameter in any cross-section from its nominal size	1; 2
	$V d_{sp}$	$\textcircled{LP} \textcircled{SR} ACS$	Range of two-point sizes of shaft washer bore diameter in any cross-section	1; 2
<i>d</i> <sub>2</sub>			Nominal bore diameter of central shaft washer, double-direction bearing	3; 4
	$\Delta d_{2mp}$	$\textcircled{LP} \textcircled{SD} ACS$	Deviation of a mid-range size (out of two-point sizes) of central shaft washer bore diameter in any cross-section from its nominal size	3; 4
	$V d_{2sp}$	$\textcircled{LP} \textcircled{SR} ACS$	Range of two-point sizes of central shaft washer bore diameter in any cross-section	3; 4
<i>D</i>			Nominal outside diameter of housing washer	1; 2; 3; 4
	$\Delta D_{mp}$	$\textcircled{LP} \textcircled{SD} ACS$	Deviation of a mid-range size (out of two-point sizes) of housing washer outside diameter in any cross-section from its nominal size	1; 2; 3; 4
	$V D_{sp}$	$\textcircled{LP} \textcircled{SR} ACS$	Range of two-point sizes of housing washer outside diameter in any cross-section	1; 2; 3; 4
<i>T</i>			Nominal assembled bearing height, single-direction bearing	1; 2
	$\Delta T_s$	$\textcircled{GN}$ <sup>e</sup>	Deviation of minimum circumscribed size of assembled bearing height from its nominal size, single-direction bearing	1; 2



Table 1 — (continued)

Symbol for nominal size <sup>a</sup>	Symbol for characteristic <sup>a</sup>	GPS symbols and specification modifiers <sup>b c</sup>	Descriptions <sup>d</sup>	See Figure
$T_1$			Nominal assembled bearing height, double-direction bearing	3; 4
	$\Delta T1s$	 <sup>e</sup>	Deviation of minimum circumscribed size of assembled bearing height from its nominal size, double-direction bearing	3; 4
	$Se^f$		<b>Thrust cylindrical roller bearings:</b> range of two-point sizes of thickness between housing washer raceway and the back face	2; 4
			<b>Thrust ball bearings:</b> range of minimum spherical sizes between the raceway and the opposite back face of the housing washer, obtained from any longitudinal section which includes the housing washer outside surface axis	1; 3
	$Si^f$		<b>Thrust cylindrical roller bearings:</b> range of two-point sizes of thickness between shaft washer raceway and the back face	2
			<b>Thrust ball bearings:</b> range of minimum spherical sizes between the raceway and the opposite back face of the shaft washer, obtained from any longitudinal section which includes the shaft washer bore axis	1

<sup>a</sup> Symbols as defined in ISO 15241[12] except for the format used.

<sup>b</sup> Symbols as defined in ISO 14405-1.

<sup>c</sup> Specification modifier  shall not be indicated on a drawing, because two-point size is the default specification modifier for size.

<sup>d</sup> Descriptions based on ISO 14405-1.

<sup>e</sup> symbols for direction of gravity  according to ISO/TS 17863, see [Figures 1 to 4](#).

<sup>f</sup> Applies only to thrust ball bearings with 90° contact angle and thrust cylindrical roller bearings with 90° contact angle.

The indications in [Figures 1 to 4](#) illustrate the correlation of interface dimensions and corresponding dimensional tolerance symbols.

NOTE [Figures 1 to 4](#) are drawn schematically and do not necessarily show all design details.

Two examples of a real drawing indication are given in [Annex B](#).

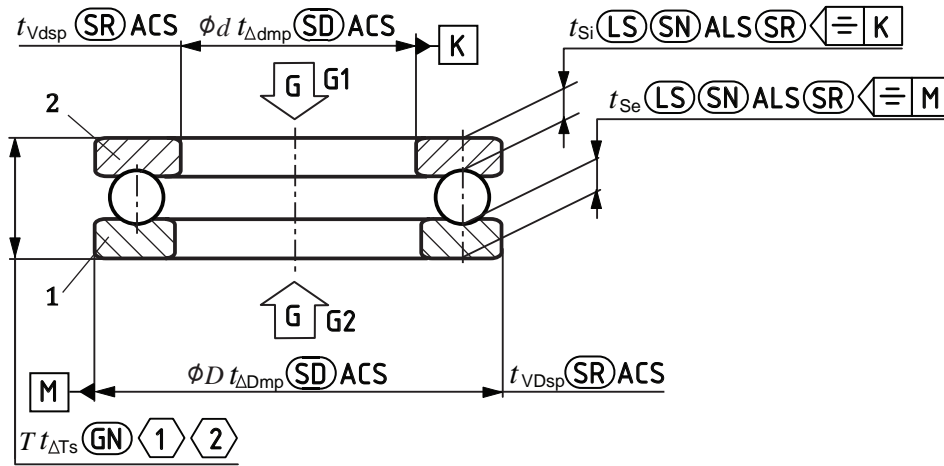

① = G1 or G2

② = the rolling elements shall be in contact with both shaft and housing washer raceways

**Key**

- 1 housing washer
- 2 shaft washer

**Figure 1 — Size specification for single-direction bearing — Thrust ball bearing**

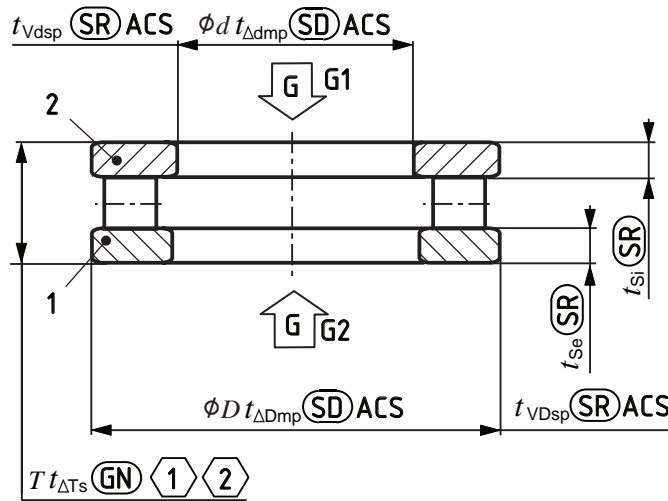

① = G1 or G2

② = the rolling elements shall be in contact with both shaft and housing washer raceways

**Key**

- 1 housing washer
- 2 shaft washer

**Figure 2 — Size specification for single-direction bearing — Thrust cylindrical roller bearing**

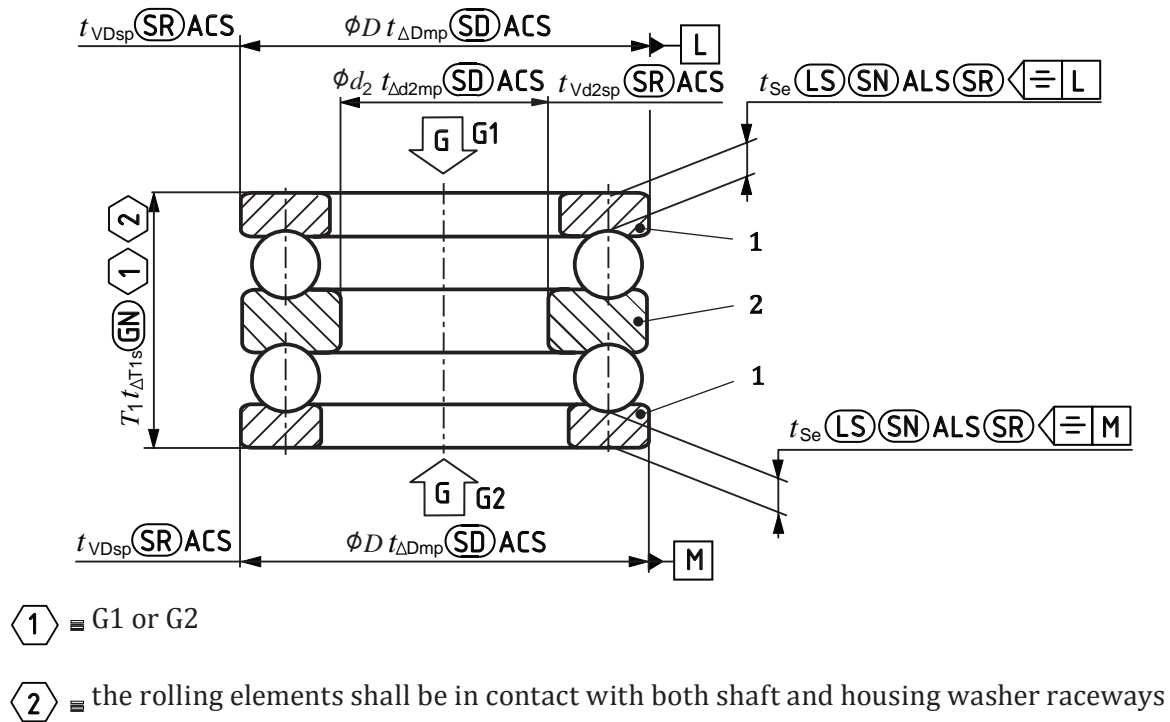

**Key**

- 1 housing washer
- 2 central shaft washer

**Figure 3 — Size specification for double-direction bearing — Thrust ball bearing**

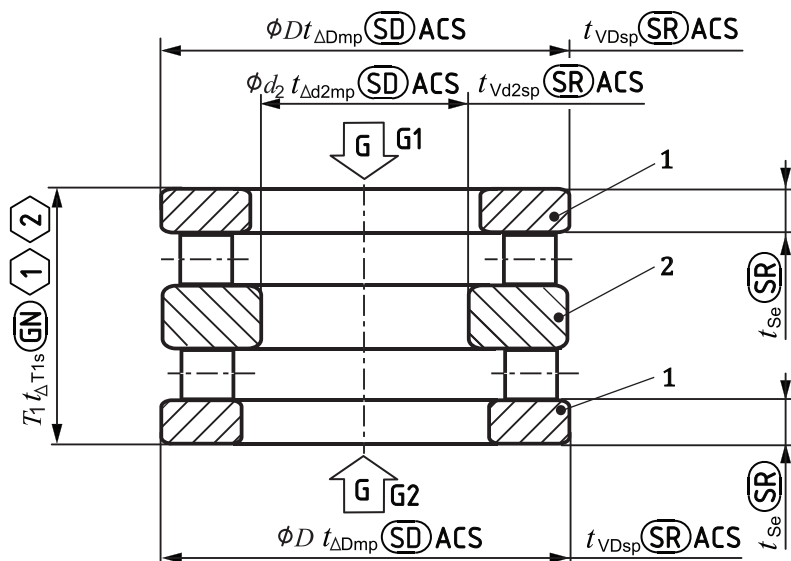

① = G1 or G2

② = the rolling elements shall be in contact with both shaft and housing washer raceways

**Key**

- 1 housing washer
- 2 central shaft washer

**Figure 4 — Size specification for double-direction bearing — Thrust cylindrical roller bearing**

## 5 Limit deviations and tolerance values

### 5.1 General

Limit deviations and tolerance values for single-direction and double-direction thrust bearings are given in [Tables 2 to 9](#).

NOTE Details, except for inner diameter, of the central washer will be dealt with in a future revision of this International Standard.

In [Tables 2 to 9](#), the symbols U and L are used as follows:

U = upper limit deviation;

L = lower limit deviation.

5.2 Tolerance class Normal

See [Tables 2](#) and [3](#).

**Table 2 — Shaft washer, central shaft washer, and bearing height — Tolerance class Normal**

Limit deviations and tolerance values in micrometers

d, d <sub>2</sub> mm		t <sub>Δdmp</sub> , t <sub>Δd2mp</sub>		t <sub>Vdsp</sub> , t <sub>Vd2sp</sub>	t <sub>Si</sub> <sup>a b</sup>	t <sub>ΔTs</sub>		t <sub>ΔT1s</sub>	
						U	L	U	L
>	≤	U	L			U	L	U	L
—	18	0	-8	6	10	+20	-250	+150	-400
18	30	0	-10	8	10	+20	-250	+150	-400
30	50	0	-12	9	10	+20	-250	+150	-400
50	80	0	-15	11	10	+20	-300	+150	-500
80	120	0	-20	15	15	+25	-300	+200	-500
120	180	0	-25	19	15	+25	-400	+200	-600
180	250	0	-30	23	20	+30	-400	+250	-600
250	315	0	-35	26	25	+40	-400	—	—
315	400	0	-40	30	30	+40	-500	—	—
400	500	0	-45	34	30	+50	-500	—	—
500	630	0	-50	38	35	+60	-600	—	—
630	800	0	-75	55	40	+70	-750	—	—
800	1 000	0	-100	75	45	+80	-1 000	—	—
1 000	1 250	0	-125	95	50	+100	-1 400	—	—
1 250	1 600	0	-160	120	60	+120	-1 600	—	—
1 600	2 000	0	-200	150	75	+140	-1 900	—	—
2 000	2 500	0	-250	190	90	+160	-2 300	—	—

NOTE For double-direction bearings, the values apply only up to and including d<sub>2</sub> = 190 mm.

<sup>a</sup> Applies only to thrust ball bearings with 90° contact angle and thrust cylindrical roller bearings with 90° contact angle.

<sup>b</sup> Is not applicable for central shaft washer.

**Table 3 — Housing washer — Tolerance class Normal**

Limit deviations and tolerance values in micrometers

$D$ mm		$t_{\Delta Dmp}$		$t_{VDsp}$	$t_{Se}^a$
$>$	$\leq$	U	L		
10	18	0	-11	8	Identical to $t_{Si}$ of shaft washer of same bearing
18	30	0	-13	10	
30	50	0	-16	12	
50	80	0	-19	14	
80	120	0	-22	17	
120	180	0	-25	19	
180	250	0	-30	23	
250	315	0	-35	26	
315	400	0	-40	30	
400	500	0	-45	34	
500	630	0	-50	38	
630	800	0	-75	55	
800	1 000	0	-100	75	
1 000	1 250	0	-125	95	
1 250	1 600	0	-160	120	
1 600	2 000	0	-200	150	
2 000	2 500	0	-250	190	
2 500	2 850	0	-300	225	

NOTE For double-direction bearings, the values apply only up to and including  $D = 360$  mm.

<sup>a</sup> Applies only to thrust ball bearings with 90° contact angle and thrust cylindrical roller bearings with 90° contact angle.

5.3 Tolerance class 6

See [Tables 4](#) and [5](#).

**Table 4 — Shaft washer, central shaft washer, and bearing height — Tolerance class 6**

Limit deviations and tolerance values in micrometers

d, d <sub>2</sub> mm		t <sub>Δdmp</sub> , t <sub>Δd2mp</sub>		t <sub>Vdsp</sub> , t <sub>Vd2sp</sub>	t <sub>Si</sub> <sup>a b</sup>	t <sub>ΔTs</sub>		t <sub>ΔT1s</sub>	
						U	L	U	L
>	≤	U	L			U	L	U	L
—	18	0	-8	6	5	+20	-250	+150	-400
18	30	0	-10	8	5	+20	-250	+150	-400
30	50	0	-12	9	6	+20	-250	+150	-400
50	80	0	-15	11	7	+20	-300	+150	-500
80	120	0	-20	15	8	+25	-300	+200	-500
120	180	0	-25	19	9	+25	-400	+200	-600
180	250	0	-30	23	10	+30	-400	+250	-600
250	315	0	-35	26	13	+40	-400	—	—
315	400	0	-40	30	15	+40	-500	—	—
400	500	0	-45	34	18	+50	-500	—	—
500	630	0	-50	38	21	+60	-600	—	—
630	800	0	-75	55	25	+70	-750	—	—
800	1 000	0	-100	75	30	+80	-1 000	—	—
1 000	1 250	0	-125	95	35	+100	-1 400	—	—
1 250	1 600	0	-160	120	40	+120	-1 600	—	—
1 600	2 000	0	-200	150	45	+140	-1 900	—	—
2 000	2 500	0	-250	190	50	+160	-2 300	—	—

NOTE For double-direction bearings, the values apply only up to and including d<sub>2</sub> = 190 mm.

<sup>a</sup> Applies only to thrust ball bearings with 90° contact angle and thrust cylindrical roller bearings with 90° contact angle.

<sup>b</sup> Is not applicable for central shaft washer.



Table 5 — Housing washer — Tolerance class 6

Limit deviations and tolerance values in micrometers

$D$ mm		$t_{\Delta Dmp}$		$t_{VDsp}$	$t_{Se}^a$
$>$	$\leq$	U	L		
10	18	0	-11	8	Identical to $t_{Si}$ of shaft washer of same bearing
18	30	0	-13	10	
30	50	0	-16	12	
50	80	0	-19	14	
80	120	0	-22	17	
120	180	0	-25	19	
180	250	0	-30	23	
250	315	0	-35	26	
315	400	0	-40	30	
400	500	0	-45	34	
500	630	0	-50	38	
630	800	0	-75	55	
800	1 000	0	-100	75	
1 000	1 250	0	-125	95	
1 250	1 600	0	-160	120	
1 600	2 000	0	-200	150	
2 000	2 500	0	-250	190	
2 500	2 850	0	-300	225	

NOTE For double-direction bearings, the values apply only up to and including  $D = 360$  mm.

<sup>a</sup> Applies only to thrust ball bearings with 90° contact angle and thrust cylindrical roller bearings with 90° contact angle.

5.4 Tolerance class 5

See Tables 6 and 7.

Table 6 — Shaft washer, central shaft washer, and bearing height — Tolerance class 5

Limit deviations and tolerance values in micrometers

d, d <sub>2</sub> mm		t <sub>Δdmp</sub> , t <sub>Δd2mp</sub>		t <sub>Vdsp</sub> , t <sub>Vd2sp</sub>	t <sub>Si</sub> <sup>a b</sup>	t <sub>ΔTs</sub>		t <sub>ΔT1s</sub>	
						U	L	U	L
>	≤	U	L			U	L	U	L
—	18	0	-8	6	3	+20	-250	+150	-400
18	30	0	-10	8	3	+20	-250	+150	-400
30	50	0	-12	9	3	+20	-250	+150	-400
50	80	0	-15	11	4	+20	-300	+150	-500
80	120	0	-20	15	4	+25	-300	+200	-500
120	180	0	-25	19	5	+25	-400	+200	-600
180	250	0	-30	23	5	+30	-400	+250	-600
250	315	0	-35	26	7	+40	-400	—	—
315	400	0	-40	30	7	+40	-500	—	—
400	500	0	-45	34	9	+50	-500	—	—
500	630	0	-50	38	11	+60	-600	—	—
630	800	0	-75	55	13	+70	-750	—	—
800	1 000	0	-100	75	15	+80	-1 000	—	—
1 000	1 250	0	-125	95	18	+100	-1 400	—	—
1 250	1 600	0	-160	120	25	+120	-1 600	—	—
1 600	2 000	0	-200	150	30	+140	-1 900	—	—
2 000	2 500	0	-250	190	40	+160	-2 300	—	—

NOTE For double-direction bearings, the values apply only up to and including d<sub>2</sub> = 190 mm.

<sup>a</sup> Applies only to thrust ball bearings with 90° contact angle and thrust cylindrical roller bearings with 90° contact angle.

<sup>b</sup> Is not applicable for central shaft washer.

Table 7 — Housing washer — Tolerance class 5

Limit deviations and tolerance values in micrometers

$D$ mm		$t_{\Delta Dmp}$		$t_{VDsp}$	$t_{Se}^a$
$>$	$\leq$	U	L		
10	18	0	-11	8	Identical to $t_{Si}$ of shaft washer of same bearing
18	30	0	-13	10	
30	50	0	-16	12	
50	80	0	-19	14	
80	120	0	-22	17	
120	180	0	-25	19	
180	250	0	-30	23	
250	315	0	-35	26	
315	400	0	-40	30	
400	500	0	-45	34	
500	630	0	-50	38	
630	800	0	-75	55	
800	1 000	0	-100	75	
1 000	1 250	0	-125	95	
1 250	1 600	0	-160	120	
1 600	2 000	0	-200	150	
2 000	2 500	0	-250	190	
2 500	2 850	0	-300	225	

NOTE For double-direction bearings, the values apply only up to and including  $D = 360$  mm.<sup>a</sup> Applies only to thrust ball bearings with 90° contact angle and thrust cylindrical roller bearings with 90° contact angle.

5.5 Tolerance class 4

See [Tables 8](#) and [9](#).

**Table 8 — Shaft washer, central shaft washer, and bearing height — Tolerance class 4**

Limit deviations and tolerance values in micrometers

$d, d_2$ mm		$t_{\Delta dmp}, t_{\Delta d2mp}$		$t_{Vdsp}, t_{Vd2sp}$	$t_{Si}$ <sup>a b</sup>	$t_{\Delta Ts}$		$t_{\Delta T1s}$	
						U	L	U	L
>	≤	U	L			U	L	U	L
—	18	0	-7	5	2	+20	-250	+150	-400
18	30	0	-8	6	2	+20	-250	+150	-400
30	50	0	-10	8	2	+20	-250	+150	-400
50	80	0	-12	9	3	+20	-300	+150	-500
80	120	0	-15	11	3	+25	-300	+200	-500
120	180	0	-18	14	4	+25	-400	+200	-600
180	250	0	-22	17	4	+30	-400	+250	-600
250	315	0	-25	19	5	+40	-400	—	—
315	400	0	-30	23	5	+40	-500	—	—
400	500	0	-35	26	6	+50	-500	—	—
500	630	0	-40	30	7	+60	-600	—	—
630	800	0	-50	40	8	+70	-750	—	—

NOTE For double-direction bearings, the values apply only up to and including  $d_2 = 190$  mm.

<sup>a</sup> Applies only to thrust ball bearings with 90° contact angle and thrust cylindrical roller bearings with 90° contact angle.

<sup>b</sup> Is not applicable for central shaft washer.

**Table 9 — Housing washer — Tolerance class 4**

Limit deviations and tolerance values in micrometers

$D$ mm		$t_{\Delta Dmp}$		$t_{VDsp}$	$t_{Se}^a$
$>$	$\leq$	U	L		
10	18	0	-7	5	Identical to $t_{Si}$ of shaft washer of same bearing
18	30	0	-8	6	
30	50	0	-9	7	
50	80	0	-11	8	
80	120	0	-13	10	
120	180	0	-15	11	
180	250	0	-20	15	
250	315	0	-25	19	
315	400	0	-28	21	
400	500	0	-33	25	
500	630	0	-38	29	
630	800	0	-45	34	
800	1 000	0	-60	45	

NOTE For double-direction bearings, the values apply only up to and including  $D = 360$  mm.

<sup>a</sup> Applies only to thrust ball bearings with 90° contact angle and thrust cylindrical roller bearings with 90° contact angle.

## Annex A (informative)

### Symbols and terms as given in ISO 199:2005 in relationship to new descriptions given in this document

**Table A.1 — Description of symbols**

Symbol for nominal size	Symbol for characteristic	Term as given in ISO 199:2005	Description given in this document
$d$		nominal bore diameter of shaft washer, single-direction bearing	nominal bore diameter of shaft washer, single-direction bearing
	$\Delta d_{mp}$	deviation of mean bore diameter in a single plane of shaft washer, single-direction bearing	deviation of a mid-range size (out of two-point sizes) of shaft washer bore diameter in any cross-section from its nominal size
	$V_{dsp}$	variation of bore diameter in a single plane of shaft washer, single-direction bearing	range of two-point sizes of shaft washer bore diameter in any cross-section
$d_2$		nominal bore diameter of central washer, double-direction bearing	nominal bore diameter of central shaft washer, double-direction bearing
	$\Delta d_{2mp}$	deviation of mean bore diameter in a single plane of central shaft washer, double-direction bearing	deviation of a mid-range size (out of two-point sizes) of central shaft washer bore diameter in any cross-section from its nominal size
	$V_{d2sp}$	variation of bore diameter in a single plane of central shaft washer, double-direction bearing	range of two-point sizes of central shaft washer bore diameter in any cross-section
$D$		nominal outside diameter of housing washer	nominal outside diameter of housing washer
	$\Delta D_{mp}$	deviation of mean outside diameter in a single plane of housing washer	deviation of a mid-range size (out of two-point sizes) of housing washer outside diameter in any cross-section from its nominal size
	$V_{Dsp}$	variation of outside diameter in a single plane of housing washer	range of two-point sizes of housing washer outside diameter in any cross-section
$T$		nominal bearing height, single-direction bearing	nominal assembled bearing height, single-direction bearing
	$\Delta T_s$	deviation of the actual bearing height, single-direction bearing	deviation of minimum circumscribed size of assembled bearing height from its nominal size, single-direction bearing

Table A.1 — (Continued)

Symbol for nominal size	Symbol for characteristic	Term as given in ISO 492:2002	Description given in this document
$T_1$		nominal bearing height, double-direction bearing	nominal assembled bearing height, double-direction bearing
	$\Delta T_{1s}$	deviation of the actual bearing height, double-direction bearing	deviation of minimum circumscribed size of assembled bearing height from its nominal size, double-direction bearing
	Se	variation in thickness between housing washer raceway and back face	<b>Thrust cylindrical roller bearing:</b> range of two-point sizes of thickness between housing washer raceway and the back face
			<b>Thrust ball bearings:</b> range of minimum spherical sizes between the raceway and the opposite back face of the housing washer, obtained from any longitudinal section which includes the housing washer outside surface axis
	Si	variation in thickness between shaft washer raceway and back face	<b>Thrust cylindrical roller bearing:</b> range of two-point sizes of thickness between shaft washer raceway and the back face
			<b>Thrust ball bearings:</b> range of minimum spherical sizes between the raceway and the opposite back face of the shaft washer, obtained from any longitudinal section which includes the shaft washer bore axis

## Annex B (informative)

### Example of drawing indications of characteristics with specification for thrust bearings

Figure B.1 gives an example of drawing indications of characteristics given in this International Standard.

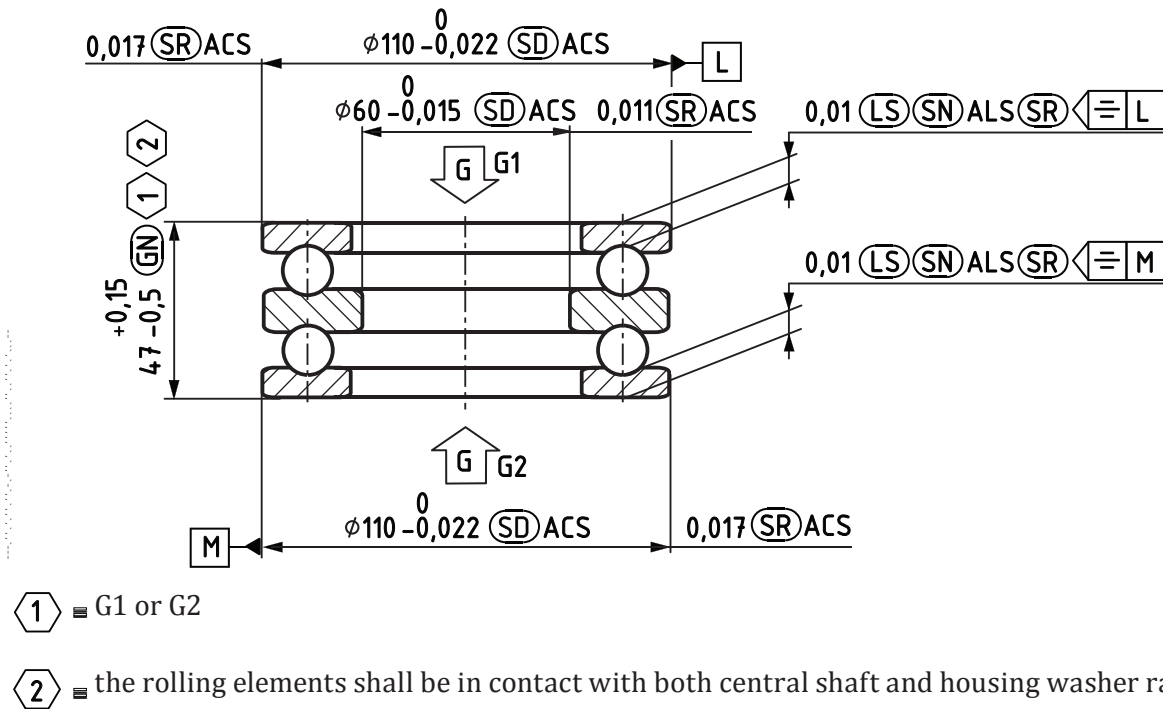

NOTE 1 Specification modifier (LP) is usually not indicated, because two-point size is the default specification for size.

NOTE 2 The dimensions and tolerance values correspond to a double-direction thrust ball bearing according to dimension series 22, bore diameter 60 mm, and tolerance class Normal.

**Figure B.1 — Drawing example**

Figure B.2 gives an example of drawing indications where tolerances are only indicated on main dimensions. For other tolerances, a reference to this International Standard and the relevant tolerance class is given.

All associated specification modifiers need to be indicated as well.



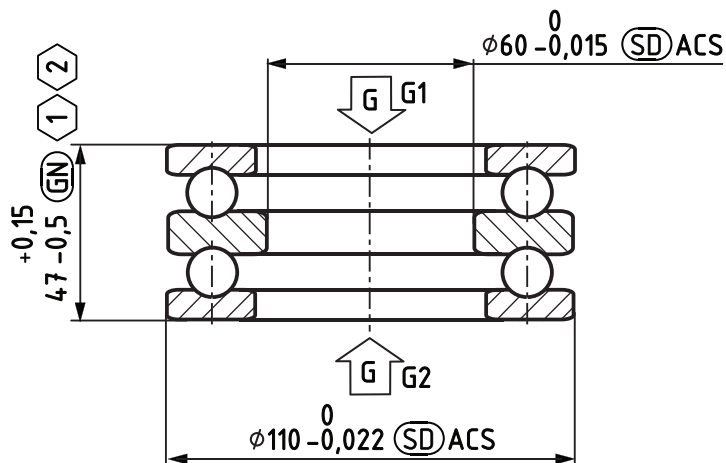

Other tolerances in accordance with ISO 199 Tolerance class Normal

① ≡ G1 or G2

② ≡ the rolling elements shall be in contact with both central shaft and housing washer raceways

**Figure B.2 — Example of drawing indications together with a specified tolerance class and standard reference**

## Annex C (informative)

### Illustration of ISO 1132-1<sup>[4]</sup> and ISO 14405-1 terms and definitions

#### C.1 General

Due to the alignment with geometrical product specifications (GPS), the terms and definitions of some tolerance characteristics have been changed. This is obvious if the terms and definitions in ISO 1132-1<sup>[4]</sup> (which were the basis of previous editions of this International Standard) and the terms and definitions in ISO/GPS standards are compared.

This Annex illustrates the differences in terms of some characteristics.

Definitions are slightly modified in order to fit to thrust bearing shaft washers. Otherwise, they are fully in line with ISO 1132-1.<sup>[4]</sup> [Figures C.1](#) to [C.3](#) do not show the proportions of a thrust bearing washer, because for better visibility of the details, a long cylinder is shown.

#### C.2 Single bore diameter versus two-point diameter

##### C.2.1 Single bore diameter according to ISO 1132-1<sup>[4]</sup>

For graphical representation, see [Figures C.1](#) and [C.2](#).

###### C.2.1.1

###### single bore diameter

$d_s$

distance between two parallel tangents to the line of intersection of the actual bore surface and any radial plane

[SOURCE: ISO 1132-1:2000, 5.1.2]

###### C.2.1.2

###### radial plane

plane perpendicular to an axis

Note 1 to entry: For a thrust bearing washer, it is generally acceptable to consider a radial plane as being parallel with the plane tangential to the back face of washer.

[SOURCE: ISO 1132-1:2000, 4.5, modified — The Note has been changed.]

###### C.2.1.3

###### washer axis

axis of the cylinder inscribed in the basically cylindrical bore of a washer

[SOURCE: ISO 1132-1:2000, 4.2, modified.]

## C.2.2 Two-point diameter according to ISO 14405-1 and ISO 14660-2<sup>[11]</sup>

For graphical representation see [Figure C.3](#).

### C.2.2.1 Terms and definitions according to ISO 14405-1

#### C.2.2.1.1

##### two-point size

<local size> distance between two opposite points taken on the feature of size

Note 1 to entry: A two-point size taken on cylinder can be called a “two-point diameter”. In ISO 14660-2,<sup>[11]</sup> this is defined as a local diameter of an extracted cylinder.

Note 2 to entry: A two-point size taken on two opposite planes can be called a “two-point distance”. In ISO 14660-2, this is defined as a local size of two parallel extracted surfaces.

[SOURCE: ISO 14405-1:2010, 3.10.1]

### C.2.2.2 Terms and definitions according to ISO 14660-2<sup>[11]</sup>

#### C.2.2.2.1

##### local size of an extracted cylinder

##### local diameter of an extracted cylinder

distance between two opposite points on the feature, where

- the connection line between the points includes the associated circle centre;
- the cross-sections are perpendicular to the axis of the associated cylinder obtained from the extracted surface

[SOURCE: ISO 14660-2:1999, 3.5]

#### C.2.2.2.2

##### extracted median line of a cylinder

locus of centres of cross-sections, where

- the centres of cross-sections are centres of associated circles;
- the cross-sections are perpendicular to the axis of the associated cylinder obtained from the extracted surface (i.e. the radius could be different from the nominal radius)

[SOURCE: ISO 14660-2:1999, 3.2]

#### C.2.2.2.3

##### extracted median line of a cylinder

For the default definition (unless otherwise specified) of the extracted median line of a cylinder, the following conditions apply:

- the associated circles are the total least squares circles;
- the associated cylinder is the total least squares cylinder.

[SOURCE: ISO 14660-2:1999, 4.1.1]

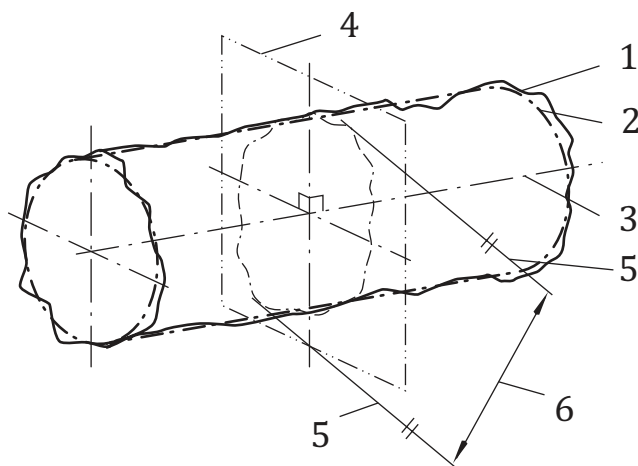

**Key**

- 1 actual bore surface (ISO 17450-1[13] real integral surface)
- 2 cylinder inscribed in the basically cylindrical bore (ISO 17450-1[13] associated integral cylinder)
- 3 axis of the cylinder inscribed in the basically cylindrical bore (ISO 17450-1[13] associated derived axis)
- 4 plane perpendicular to the axis
- 5 two parallel tangents to the line of intersection of the actual bore surface and any radial plane
- 6 single bore diameter

**Figure C.1 — Single bore diameter**

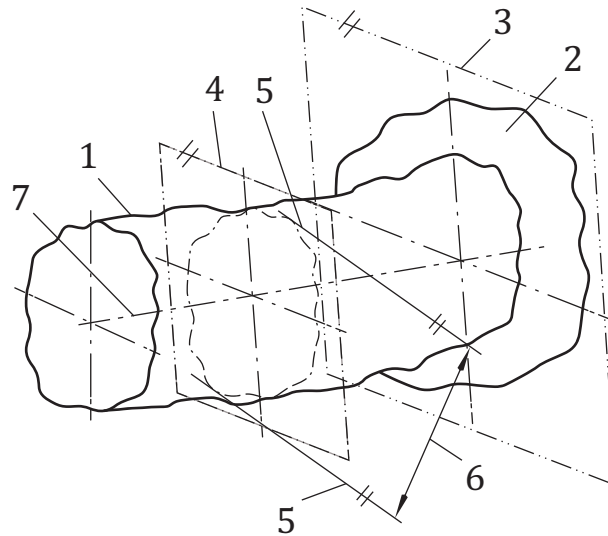

### Key

- 1 actual bore surface (ISO 17450-1[13] real integral surface)
- 2 actual back face of the shaft washer (ISO 17450-1[13] real integral surface)
- 3 plane tangential to the actual back face of the shaft washer
- 4 plane parallel with the plane tangential to the actual back face of the shaft washer
- 5 two parallel tangents to the line of intersection of the actual bore surface and a plane parallel with the plane tangential to the actual back face of the shaft washer
- 6 single bore diameter
- 7 axis of the cylinder inscribed in the basically cylindrical bore (ISO 17450-1[13] associated derived axis) which is not perpendicular to the plane tangential to the back face of the shaft washer

**Figure C.2 — Single bore diameter with radial plane parallel with a plane tangential to the reference face of the shaft washer**

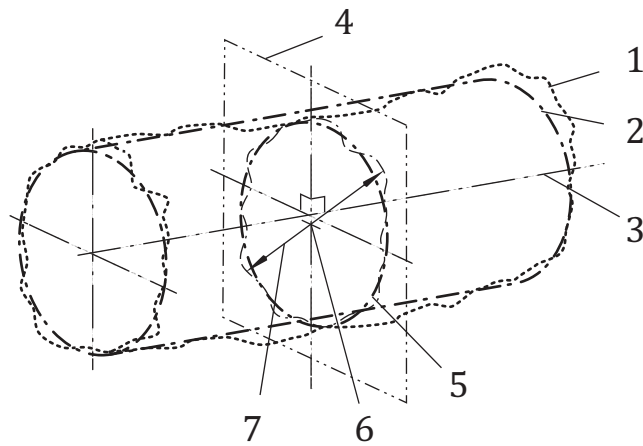

**Key**

- 1 extracted bore surface
- 2 associated cylinder (total least squares cylinder)
- 3 associated cylinder axis
- 4 plane perpendicular to the associated axis
- 5 associated circle (total least squares circle)
- 6 associated circle centre
- 7 example of a two-point diameter

**Figure C.3 — Two-point diameter**

## Annex D (informative)

### Description with illustrations for specification modifiers of linear sizes

#### D.1 General

The symbols for specification modifiers of linear sizes used in this International Standard are specified in ISO 14405-1. This Annex mentions the descriptions with illustrations as terms and definitions of symbols for specification modifiers given in ISO 14405-1.

#### D.2 Specification modifiers and symbols

[Table D.1](#) shows symbols for specification modifiers for linear sizes. These definitions are given in [D.3](#).

[Table D.2](#) shows combinations of symbols for specification modifiers. These descriptions are mentioned in [D.4](#).

**Table D.1 — Specification modifiers for linear sizes**

Symbol for specification modifier	Term	ISO 14405-1:2010 clause	Description with illustration
(LP)	Two-point size	3.10.1	<a href="#">Figure D.1</a>
(SD)	Mid-range size	3.11.2.2.5	—
(SR)	Range of size	3.11.2.2.6	—
(LS)	Spherical size (local size defined by a sphere)	3.10.4	<a href="#">Figure D.2</a>
(GN)	Minimum circumscribed size	3.11.1.3	<a href="#">Figure D.3</a>
ACS	Any cross-section	7.4	<a href="#">Figure D.4</a>
ALS 	Any longitudinal section constructed by intersection plane	—	<a href="#">Figures D.5</a>
(SN)	Minimum size	3.11.2.2.2	<a href="#">Figure D.6</a>

<sup>a</sup> Symbol for datum to be indicated.

**Table D.2 — Combination of symbols for specification modifiers**

Combination of symbols for specification modifier	Symbol for characteristic	Description according to <a href="#">Table 1</a>	Description with illustration
	Se	<b>Thrust ball bearings:</b> range of minimum spherical size between the raceway and the opposite back face of the housing washer, obtained from any longitudinal section which includes the housing washer outside outside surface axis	<a href="#">Figure D.6</a>
	Si	<b>Thrust ball bearings:</b> range of minimum spherical size between the raceway and the opposite back face of the shaft washer, obtained from any longitudinal section which includes the shaft washer bore axis	

<sup>a</sup> Symbol for datum to be indicated.

### D.3 Terms, definitions and modifiers specified in ISO 14405-1 and descriptions with illustrations

The following shows the terms and definitions of specification modifiers and description of general specification modifier specified in ISO 14405-1, together with the illustrations for the descriptions of specification modifiers.

#### D.3.1

##### specification modifier

GPS specification element that changes the default definition of the basic GPS specification when applied

Note 1 to entry: Specification modifiers can be defined by International Standards, national standards or company standards/documents.

[SOURCE: ISO 14405-1:2010, 3.1]

#### D.3.2

##### feature of size

geometrical shape defined by a linear or angular dimension which is a *size* (D.3.3)

Note 1 to entry: The features of size can be a cylinder, a sphere, two parallel opposite surfaces, a cone or a wedge.

Note 2 to entry: In International Standards such as ISO 286-1[2] and ISO 1938-1,[6] the meanings of the terms “plain workpiece” and “single features” are close to that of “feature of size”.

[SOURCE: ISO 14405-1:2010, 3.2, modified – NOTE 3 omitted]

#### D.3.3

##### size

intrinsic characteristic of a *feature of size* (D.3.2) that can be defined on a nominal feature or on an associated feature



Note 1 to entry: In ISO 14405-1, the size corresponds to the diameter of a cylinder or to the distance between two parallel opposite planes. Depending on the type of feature of size, the terms “diameter” and “distance” are synonyms for size.

[SOURCE: ISO 14405-1:2010, 3.8 – NOTE 2 omitted]

#### D.3.4

##### size characteristic

characteristic relative to a *size* (D.3.3) and defined on an extracted feature

Note 1 to entry: A size can be evaluated by more than one size characteristic (e.g. the two-point diameter or the diameter of the associated feature, taken on the extracted feature).

[SOURCE: ISO 14405-1:2010, 3.9]

#### D.3.5

##### local size

*size characteristic* (D.3.4) having by definition a non-unique result of evaluation along and/or around the *feature of size* (D.3.2)

Note 1 to entry: For a given feature, an infinity of local sizes exists.

Note 2 to entry: In ISO 14405-1, “local size” is used instead of “local linear size”.

[SOURCE: ISO 14405-1:2010, 3.10, modified — Alternative term and NOTE 3 omitted]

#### D.3.6

##### two-point size

(*local size* (D.3.5)) distance between two opposite points taken on the *feature of size* (D.3.2)

Note 1 to entry: A two-point size taken on cylinder can be called a “two-point diameter”. In ISO 14660-2,<sup>[11]</sup> this is defined as a local diameter of an extracted cylinder.

Note 2 to entry: A two-point size taken on two opposite planes can be called a “two-point distance”. In ISO 14660-2,<sup>[11]</sup> this is defined as a *local size* (D.3.5) of two parallel extracted surfaces.

[SOURCE: ISO 14405-1:2010, 3.10.1]

See [Figure D.1](#).

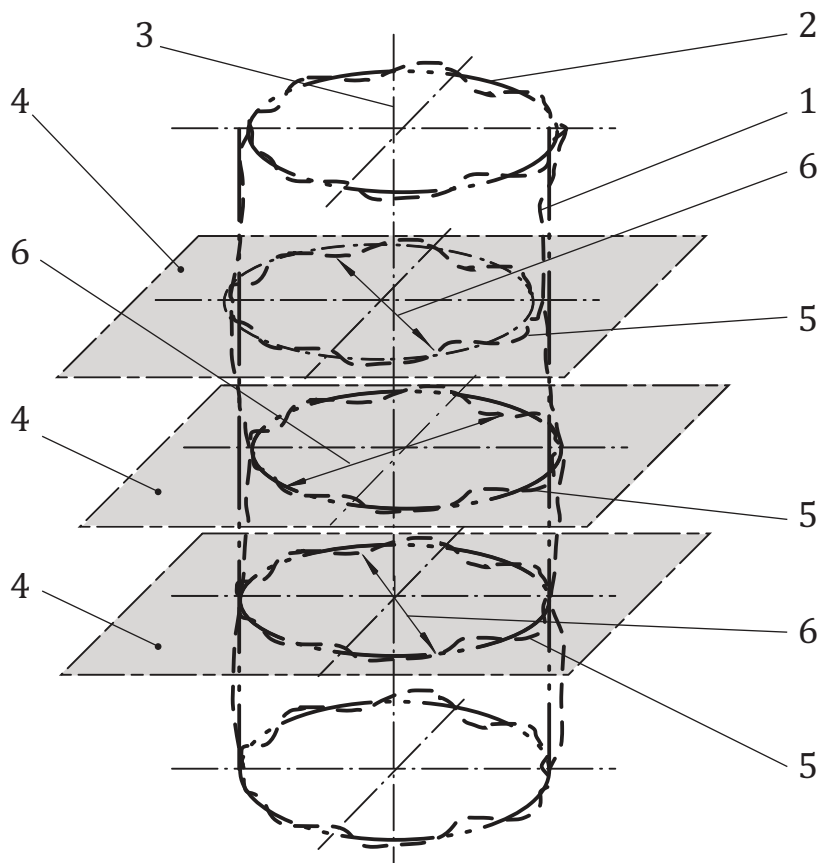

**Key**

- 1 extracted cylinder
- 2 associated cylinder
- 3 associated cylinder axis
- 4 any one of an infinite number of planes perpendicular to the associated axis
- 5 extracted circle
- 6 two-point size (diameter)

NOTE Three cross-sections are shown, but analogous to D.3.5 Note 1, infinity of cross-sections exist.

**Figure D.1 — Two-point size**

**D.3.7**

**rank-order size**

*size characteristic* (D.3.4) defined mathematically from a homogeneous set of *local size* (D.3.5) values obtained along and/or around the tolerance feature

Note 1 to entry: A rank-order size can be used to define an *indirect global size* (ISO 14405-1:2010, 3.11.2) (for example, an average of a set of two-point size values taken on the extracted cylindrical surface) from a local size [*two-point size* (D.3.6)].

Note 2 to entry: A rank-order size can be used to define a local size from another local size (for example, to define a rank-order section size from a two-point size taken in the section).

[SOURCE: ISO 14405-1:2010, 3.11.2.2, modified — Notes 1 and 2 have been altered and Note 3 omitted.]

**D.3.8**

**mid-range size**

*rank-order size* (D.3.7) defined as the mean of the maximum and the minimum of the set of values of a *local size* (D.3.5) along and/or around the tolerance feature

[SOURCE: ISO 14405-1:2010, 3.11.2.2.5]

The specification of mid-range size should be indicated on the drawing with the modifier **(SD)**.

**D.3.9****range of sizes**

*rank-order size* (D.3.7) defined as the difference between the maximum and the minimum of the set of values of a *local size* (D.3.5) along and/or around the tolerated feature

[SOURCE: ISO 14405-1:2010, 3.11.2.2.6]

The specification of range of size should be indicated on the drawing with the modifier **(SR)**.

**D.3.10****spherical size**

<local size> diameter of the maximum inscribed sphere

Note 1 to entry: This local size, defined by a sphere, applies to the feature of size types “cylinder” and “two parallel opposite planes”.

[SOURCE: ISO 14405-1:2010, 3.10.4]

See [Figure D.2](#).

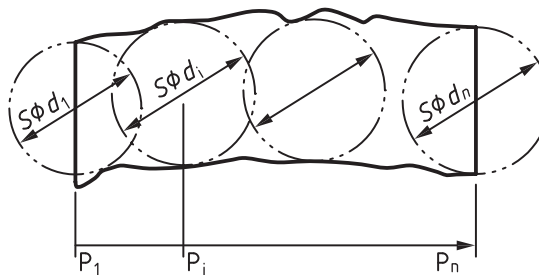
**Key**

P position

$S\phi d$  diameter of the maximum inscribed sphere

NOTE Four spheres are shown, but infinity of spheres exists.

**Figure D.2 — Spherical size**

**D.3.11****minimum circumscribed size**

<global size> *size* (D.3.3) of the associated feature established from the extracted feature(s) with the minimum circumscribed criterion

Note 1 to entry: In the case of an external feature of size, the minimum circumscribed size was previously called “mating size for an external feature”.

[SOURCE: ISO 14405-1:2010, 3.11.1.3]

See [Figure D.3](#).

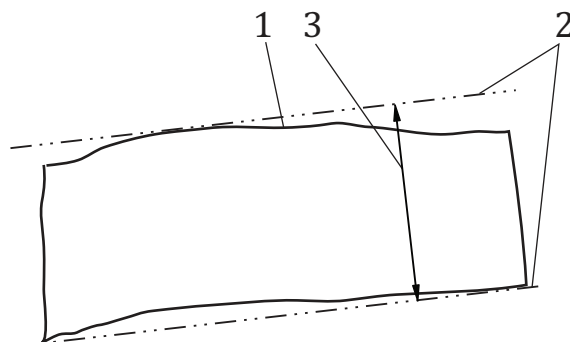

**Key**

- 1 extracted feature
- 2 parallel planes or parallel lines
- 3 minimum distance between parallel planes or parallel lines

**Figure D.3 — Minimum circumscribed size**

**D.3.12**

**minimum size**

*rank-order size* (D.3.7) defined as the minimum of set of values of a *local size* (D.3.5) along and/or around the tolerated feature

[SOURCE: ISO 14405-1:2010, 3.11.2.2.2]

**D.3.13**

**any cross section of a feature of size (ACS)**

If the specification applies to any cross section of either the complete feature of size or a fixed restricted portion of it, it should be indicated with the specification modifier “ACS”, or the cross section should be tolerated and indicated on the drawing and the specification modifier “ACS” should be added to that tolerance.

[SOURCE: ISO 14405-1:2010, 7.4, modified – shortened text]

See [Figure D.4](#).



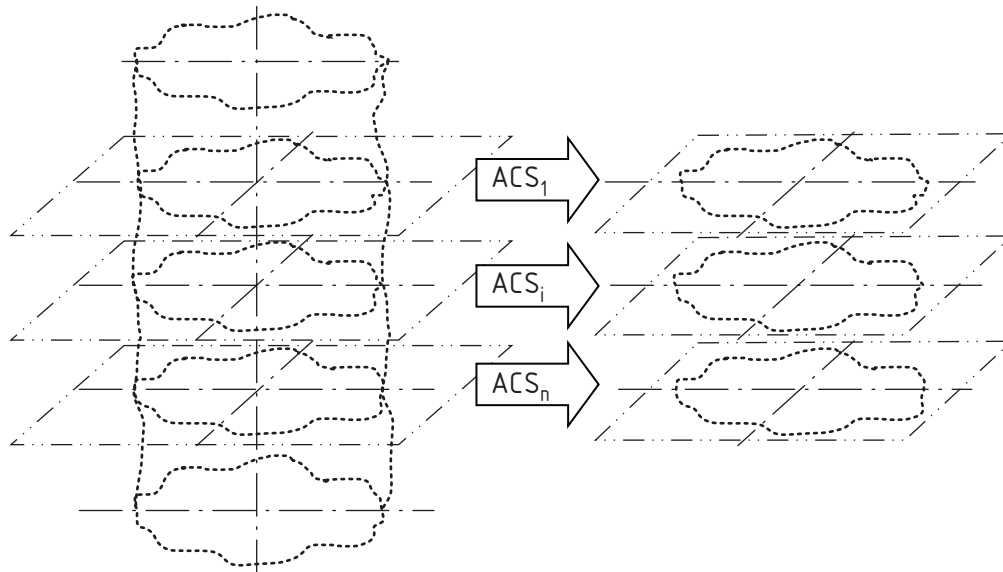

NOTE Three cross-sections are shown, but analogous to D.3.5, NOTE 1, infinity of cross sections exists.

Figure D.4 — Any cross-section (ACS)

## D.4 Additional terms and descriptions with illustrations

### D.4.1 Any longitudinal section of a feature of size (ALS)

If the specification applies to any longitudinal section of the complete feature of size (D.3.2), it shall be indicated with the specification modifier “ALS”

See [Figure D.5](#).

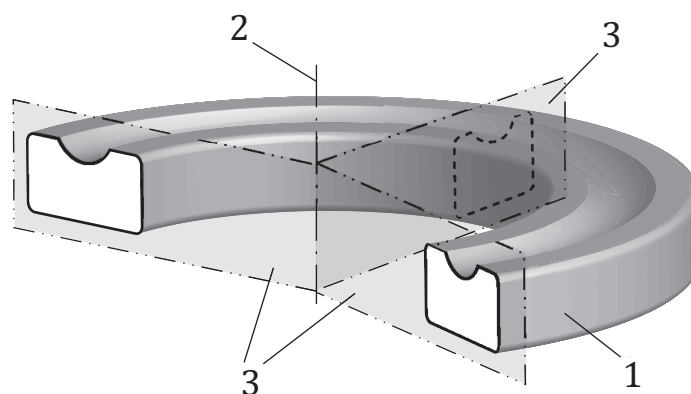

#### Key

- 1 associated cylinder
- 2 associated cylinder axis
- 3 ALS (any longitudinal section) which includes the outside surface axis

NOTE Three longitudinal sections are shown, but infinity of longitudinal sections exists.

Figure D.5 — Any longitudinal section (ALS)

## D.5 Combination of symbols for specification modifiers

### D.5.1 General

Symbols for specification modifiers often are used in combination. The following shows descriptions of the combinations of specification modifiers specified in ISO 14405-1, together with the illustrations for the descriptions of the combinations of specification modifiers.

### D.5.2 Example of symbols combination: $\text{LS} \text{SN} \text{ALS} \text{SR} \leftarrow \text{M}$

For  $\text{SN}$  see [Figure D.6](#).

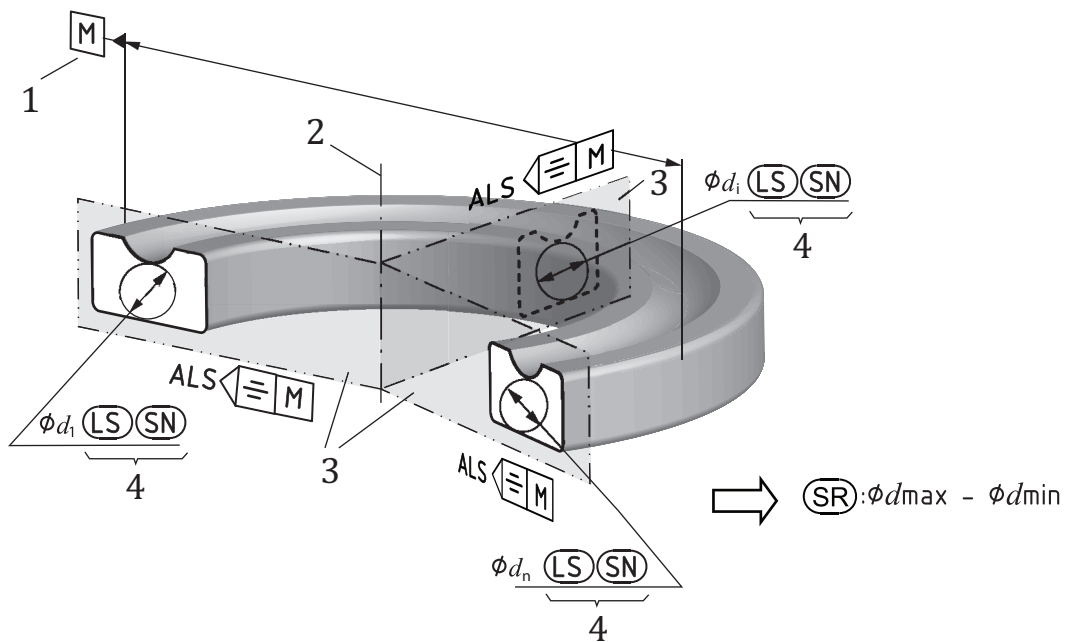

#### Key

- 1 datum feature indication
- 2 associated cylinder axis
- 3 ALS (any longitudinal section) including outside surface axis (Datum M)
- 4 smallest sphere out of a set of maximum inscribed spheres in any longitudinal section (ALS)

NOTE Three longitudinal sections are shown, but infinity of longitudinal sections exists.

Figure D.6 — Combination of symbols:  $\text{LS} \text{SN} \text{ALS} \text{SR} \leftarrow \text{M}$

## Bibliography

- [1] ISO 104, *Rolling bearings — Thrust bearings — Boundary dimensions, general plan*
- [2] ISO 286-1, *Geometrical product specifications (GPS) — ISO code system for tolerances on linear sizes — Part 1: Basis of tolerances, deviations and fits*
- [3] ISO 582, *Rolling bearings — Chamfer dimensions — Maximum values*
- [4] ISO 1132-1, *Rolling bearings — Tolerances — Part 1: Terms and definitions*
- [5] ISO 1132-2, *Rolling bearings — Tolerances — Part 2: Measuring and gauging principles and methods*
- [6] ISO 1938-1:—<sup>1)</sup>, *Geometrical product specifications (GPS) — Dimensional measuring equipment — Part 1: Plain limit gauges of linear size*
- [7] ISO 8015, *Geometrical product specifications (GPS) — Fundamentals — Concepts, principles and rules*
- [8] ISO 14253-1, *Geometrical product specifications (GPS) — Inspection by measurement of workpieces and measuring equipment — Part 1: Decision rules for proving conformity or nonconformity with specifications*
- [9] ISO 14253-2, *Geometrical product specifications (GPS) — Inspection by measurement of workpieces and measuring equipment — Part 2: Guidance for the estimation of uncertainty in GPS measurement, in calibration of measuring equipment and in product verification*
- [10] ISO/TR 14638, *Geometrical product specification (GPS) — Masterplan*
- [11] ISO 14660-2, *Geometrical Product Specifications (GPS) — Geometrical features — Part 2: Extracted median line of a cylinder and a cone, extracted median surface, local size of an extracted feature*
- [12] ISO 15241, *Rolling bearings — Symbols for physical quantities*
- [13] ISO 17450-1, *Geometrical product specifications (GPS) — General concepts — Part 1: Model for geometrical specification and verification*

---

1) To be published.

---

---

**ICS 21.100.20**

Price based on 30 pages