**Plastics — Determination of Charpy
impact properties —**

**Part 1:
Non-instrumented impact test**

*Plastiques — Détermination des caractéristiques au choc Charpy —
Partie 1: Essai de choc non instrumenté*



Reference number
ISO 179-1:2010(E)

© ISO 2010

PDF disclaimer

This PDF file may contain embedded typefaces. In accordance with Adobe's licensing policy, this file may be printed or viewed but shall not be edited unless the typefaces which are embedded are licensed to and installed on the computer performing the editing. In downloading this file, parties accept therein the responsibility of not infringing Adobe's licensing policy. The ISO Central Secretariat accepts no liability in this area.

Adobe is a trademark of Adobe Systems Incorporated.

Details of the software products used to create this PDF file can be found in the General Info relative to the file; the PDF-creation parameters were optimized for printing. Every care has been taken to ensure that the file is suitable for use by ISO member bodies. In the unlikely event that a problem relating to it is found, please inform the Central Secretariat at the address given below.



COPYRIGHT PROTECTED DOCUMENT

© ISO 2010

All rights reserved. Unless otherwise specified, no part of this publication may be reproduced or utilized in any form or by any means, electronic or mechanical, including photocopying and microfilm, without permission in writing from either ISO at the address below or ISO's member body in the country of the requester.

ISO copyright office
Case postale 56 • CH-1211 Geneva 20
Tel. + 41 22 749 01 11
Fax + 41 22 749 09 47
E-mail copyright@iso.org
Web www.iso.org

Published in Switzerland

Contents

Page

Foreword	iv
1 Scope	1
2 Normative references	2
3 Terms and definitions	2
4 Principle.....	3
5 Apparatus	3
5.1 Test machine.....	3
5.2 Micrometers and gauges	3
6 Test specimens.....	4
6.1 Preparation.....	4
6.1.1 Moulding and extrusion compounds	4
6.1.2 Sheets	4
6.1.3 Long-fibre-reinforced materials	4
6.1.4 Checking.....	7
6.1.5 Notching	7
6.2 Anisotropy.....	7
6.3 Shape and dimensions	8
6.3.1 Materials not exhibiting interlaminar shear fracture	8
6.3.2 Materials exhibiting interlaminar shear fracture (e.g. long-fibre-reinforced materials).....	9
6.4 Number of test specimens.....	9
6.5 Definition of span between specimen supports, L	10
6.6 Conditioning	11
7 Procedure	11
8 Calculation and expression of results	12
8.1 Unnotched specimens	12
8.2 Notched specimens.....	12
8.3 Statistical parameters	13
8.4 Significant figures	13
9 Precision.....	13
10 Test report.....	13
Annex A (informative) Additional methods for investigating the influence of surface effects.....	15
Annex B (informative) Precision data	17
Annex C (informative) Determining the notch tip radius using a CCD microscope	19
Bibliography.....	22

Foreword

ISO (the International Organization for Standardization) is a worldwide federation of national standards bodies (ISO member bodies). The work of preparing International Standards is normally carried out through ISO technical committees. Each member body interested in a subject for which a technical committee has been established has the right to be represented on that committee. International organizations, governmental and non-governmental, in liaison with ISO, also take part in the work. ISO collaborates closely with the International Electrotechnical Commission (IEC) on all matters of electrotechnical standardization.

International Standards are drafted in accordance with the rules given in the ISO/IEC Directives, Part 2.

The main task of technical committees is to prepare International Standards. Draft International Standards adopted by the technical committees are circulated to the member bodies for voting. Publication as an International Standard requires approval by at least 75 % of the member bodies casting a vote.

Attention is drawn to the possibility that some of the elements of this document may be the subject of patent rights. ISO shall not be held responsible for identifying any or all such patent rights.

ISO 179-1 was prepared by Technical Committee ISO/TC 61, *Plastics*, Subcommittee SC 2, *Mechanical properties*.

This second edition cancels and replaces the first edition (ISO 179-1:2000), which has been technically revised. The main changes are as follows:

- a new subclause (6.5) has been added, defining the span between the specimen supports and indicating a convenient position at which it can be measured;
- a new annex, Annex C, has been added, giving a method of measuring the radius of the notch in a notched specimen.

This second edition also incorporates the Amendment ISO 179-1:2000/Amd.1:2005.

ISO 179 consists of the following parts, under the general title *Plastics — Determination of Charpy impact properties*:

- *Part 1: Non-instrumented impact test*
- *Part 2: Instrumented impact test*

Plastics — Determination of Charpy impact properties —

Part 1: Non-instrumented impact test

1 Scope

1.1 This part of ISO 179 specifies a method for determining the Charpy impact strength of plastics under defined conditions. A number of different types of specimen and test configurations are defined. Different test parameters are specified according to the type of material, the type of test specimen and the type of notch.

1.2 The method can be used to investigate the behaviour of specified types of specimen under the impact conditions defined and for estimating the brittleness or toughness of specimens within the limitations inherent in the test conditions. It can also be used for the determination of comparative data from similar types of material.

1.3 The method has a greater range of applicability than that given in ISO 180^[1] and is more suitable for the testing of materials showing interlaminar shear fracture or of materials exhibiting surface effects due to environmental factors.

1.4 The method is suitable for use with the following range of materials:

- rigid thermoplastic moulding and extrusion materials (including filled and reinforced compounds in addition to unfilled types) and rigid thermoplastics sheets;
- rigid thermosetting moulding materials (including filled and reinforced compounds) and rigid thermosetting sheets (including laminates);
- fibre-reinforced thermosetting and thermoplastic composites incorporating unidirectional or multi-directional reinforcements (such as mats, woven fabrics, woven rovings, chopped strands, combination and hybrid reinforcements, rovings and milled fibres) or incorporating sheets made from pre-impregnated materials (prepregs), including filled and reinforced compounds;
- thermotropic liquid-crystal polymers.

1.5 Notched samples are not normally suitable for use with rigid cellular materials, long-fibre-reinforced composites or thermotropic liquid-crystal polymers. In these cases, unnotched samples may be used.

1.6 The method is suited to the use of specimens moulded to the chosen dimensions, machined from the central portion of a standard multipurpose test specimen (see ISO 3167) or machined from finished or semifinished products such as mouldings, laminates and extruded or cast sheet.

1.7 The method specifies preferred dimensions for the test specimen. Tests which are carried out on specimens of different dimensions or with different notches, or specimens which are prepared under different conditions, might produce results which are not comparable. Other factors, such as the energy capacity of the apparatus, the impact velocity and the conditioning of the specimens can also influence the results. Consequently, when comparative data are required, these factors must be carefully controlled and recorded.

1.8 The method should not be used as a source of data for design calculations. Information on the typical behaviour of a material can be obtained, however, by testing at different temperatures, by varying the notch radius and/or the specimen thickness and by testing specimens prepared under different conditions.

2 Normative references

The following referenced documents are indispensable for the application of this document. For dated references, only the edition cited applies. For undated references, the latest edition of the referenced document (including any amendments) applies.

ISO 291, *Plastics — Standard atmospheres for conditioning and testing*

ISO 293, *Plastics — Compression moulding of test specimens of thermoplastic materials*

ISO 294-1, *Plastics — Injection moulding of test specimens of thermoplastic materials — Part 1: General principles, and moulding of multipurpose and bar test specimens*

ISO 294-3, *Plastics — Injection moulding of test specimens of thermoplastic materials — Part 3: Small plates*

ISO 295, *Plastics — Compression moulding of test specimens of thermosetting materials*

ISO 1268-11, *Fibre-reinforced plastics — Methods of producing test plates — Part 11: Injection moulding of BMC and other long-fibre moulding compounds — Small plates*

ISO 2602, *Statistical interpretation of test results — Estimation of the mean — Confidence interval*

ISO 2818, *Plastics — Preparation of test specimens by machining*

ISO 3167, *Plastics — Multipurpose test specimens*

ISO 10724-1, *Plastics — Injection moulding of test specimens of thermosetting powder moulding compounds (PMCs) — Part 1: General principles and moulding of multipurpose test specimens*

ISO 13802, *Plastics — Verification of pendulum impact-testing machines — Charpy, Izod and tensile impact-testing*

3 Terms and definitions

For the purposes of this document, the following terms and definitions apply.

3.1

Charpy unnotched impact strength

a_{cU}
impact energy absorbed in breaking an unnotched specimen, referred to the original cross-sectional area of the specimen

NOTE It is expressed in kilojoules per square metre (kJ/m²).

3.2

Charpy notched impact strength

a_{cN}
impact energy absorbed in breaking a notched specimen, referred to the original cross-sectional area of the specimen at the notch, where N = A, B or C, depending on the notch type (see 6.3.1.1.2)

NOTE It is expressed in kilojoules per square metre (kJ/m²).

3.3 edgewise impact

e

direction of blow parallel to the dimension b , with impact on the narrow longitudinal surface $h \times l$ of the specimen (see Figure 1, left, and Figures 2 and 4)

3.4 flatwise impact

f

direction of blow parallel to the dimension h , with impact on the broad longitudinal surface $b \times l$ of the specimen (see Figure 1, right, and Figures 3 and 4)

3.5 normal impact

n

(laminar-reinforced plastics) impact with the direction of blow normal to the plane of reinforcement (see Figure 4)

3.6 parallel impact

p

(laminar-reinforced plastics) impact with the direction of blow parallel to the plane of reinforcement (see Figure 4)

4 Principle

The test specimen, supported near its ends as a horizontal beam, is impacted by a single blow of a striker, with the line of impact midway between the supports, and bent at a high, nominally constant, velocity.

In the case of edgewise impact with notched specimens, the line of impact is directly opposite the single notch (see Figure 1, left, and Figure 2).

5 Apparatus

5.1 Test machine

The principles, characteristics and verification of suitable test machines are detailed in ISO 13802.

ISO 13802 describes partial verification and full verification. In the case of full verification, some items are difficult to verify when the apparatus is assembled. Such verifications are assumed to be incumbent on the manufacturer.

5.2 Micrometers and gauges

Micrometers and gauges capable of measuring the essential dimensions of test specimens to an accuracy of 0,02 mm are required. For measuring the dimension b_N of notched specimens, the micrometer shall have a spindle with a measuring tip having a suitable profile to fit the shape of the notch.

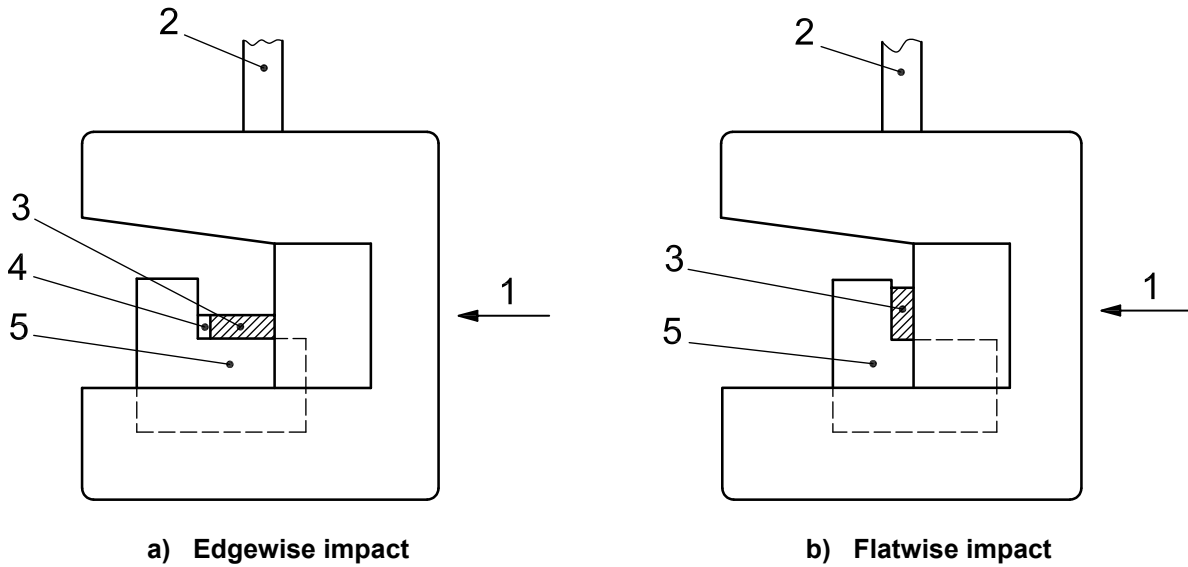

Key

- 1 direction of blow
- 2 rod of pendulum
- 3 test specimen
- 4 notch
- 5 support

Figure 1 — Striking edge and support blocks for type 1 test specimen at moment of impact

6 Test specimens

6.1 Preparation

6.1.1 Moulding and extrusion compounds

Specimens shall be prepared in accordance with the relevant material specification. The specimens shall be either directly compression moulded in accordance with ISO 293 or ISO 295 or injection moulded from the material in accordance with ISO 294-1, ISO 294-3 or ISO 10724-1, as appropriate, or machined in accordance with ISO 2818 from sheet that has been compression or injection moulded from the compound. Type 1 specimens may be cut from multipurpose test specimens complying with ISO 3167, type A.

6.1.2 Sheets

Specimens shall be machined from sheets in accordance with ISO 2818.

6.1.3 Long-fibre-reinforced materials

A panel shall be prepared in accordance with ISO 1268-11 or another specified or agreed upon preparation procedure. Specimens shall be machined in accordance with ISO 2818.

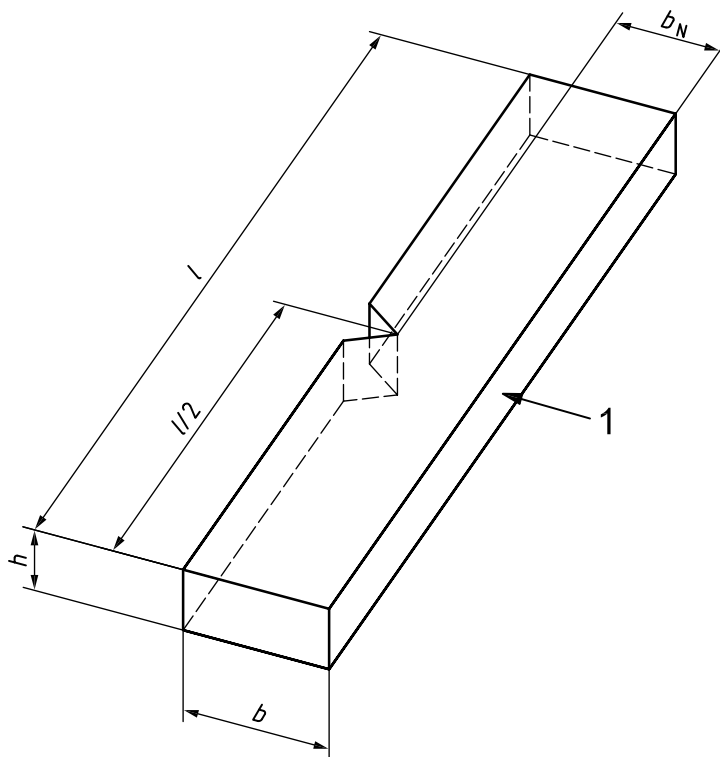

Key

1 direction of blow

Figure 2 — Charpy edgewise impact (e) with single-notched specimen

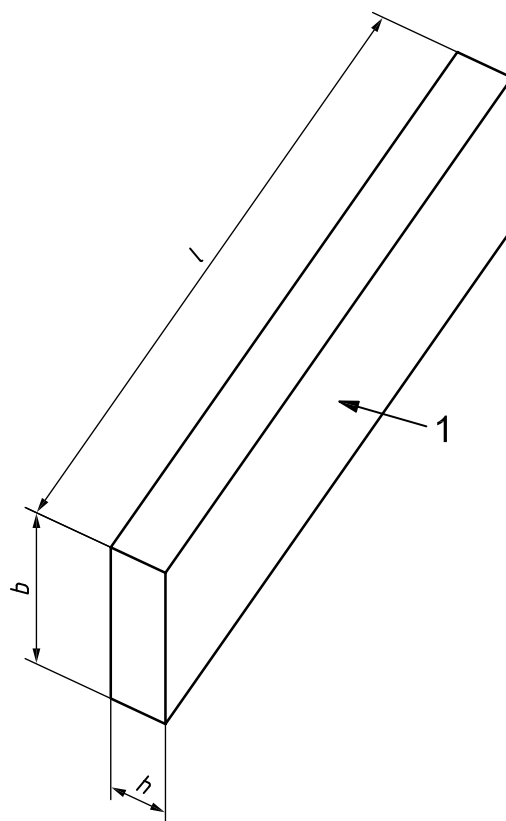

Key

1 direction of blow

Figure 3 — Charpy flatwise impact (f)

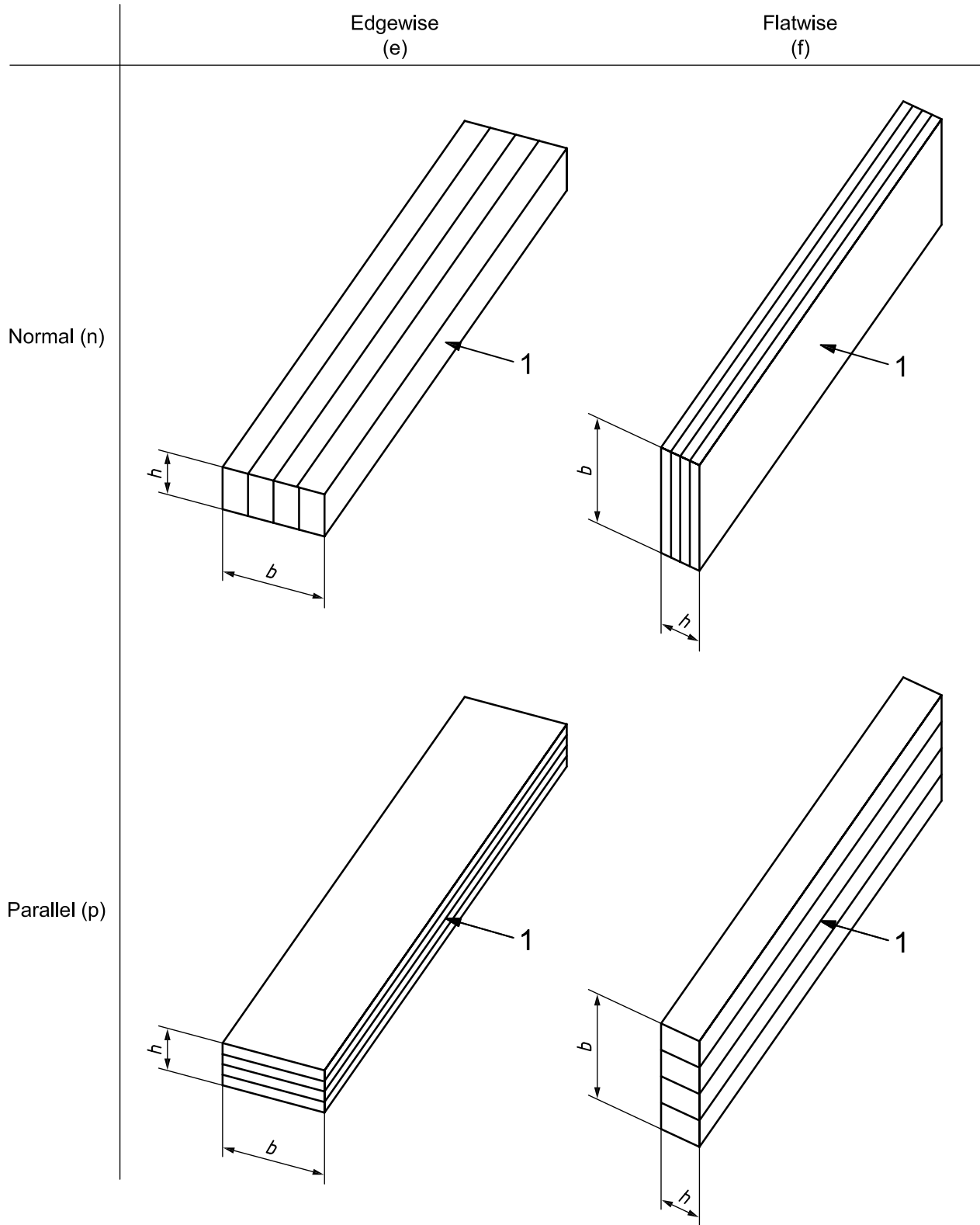

Key

1 direction of blow

Edgewise (e) and flatwise (f) indicate the direction of the blow with respect to the specimen thickness, h , and specimen width, b . Normal (n) and parallel (p) indicate the direction of the blow with respect to the laminate plane.

The Charpy “fn” and “ep” tests are used for laminates, while both the Charpy “en” and “ep” tests are used for other materials. The Charpy “fn” and “fp” tests are used for testing materials exhibiting surface effects.

Figure 4 — Scheme of designations describing the direction of blow

6.1.4 Checking

The specimens shall be free of twist and shall have mutually perpendicular parallel surfaces. The surfaces and edges shall be free from scratches, pits, sink marks and flash.

The specimens shall be checked for conformity with these requirements by visual observation against straightedges, set squares and flat plates, and by measuring with micrometer callipers.

Specimens showing measurable or observable departure from one or more of these requirements shall be rejected or machined to proper size and shape before testing.

6.1.5 Notching

6.1.5.1 Machined notches shall be prepared in accordance with ISO 2818. The profile of the cutting tooth shall be such as to produce in the specimen a notch of the contour and depth shown in Figure 5, at right angles to its principal axes (see Note).

NOTE The radius of the notch tip can be measured by the method given in Annex C.

6.1.5.2 Specimens with moulded-in notches may be used if specified for the material being tested (see Note).

NOTE Specimens with moulded-in notches do not give results comparable to those obtained from specimens with machined notches.

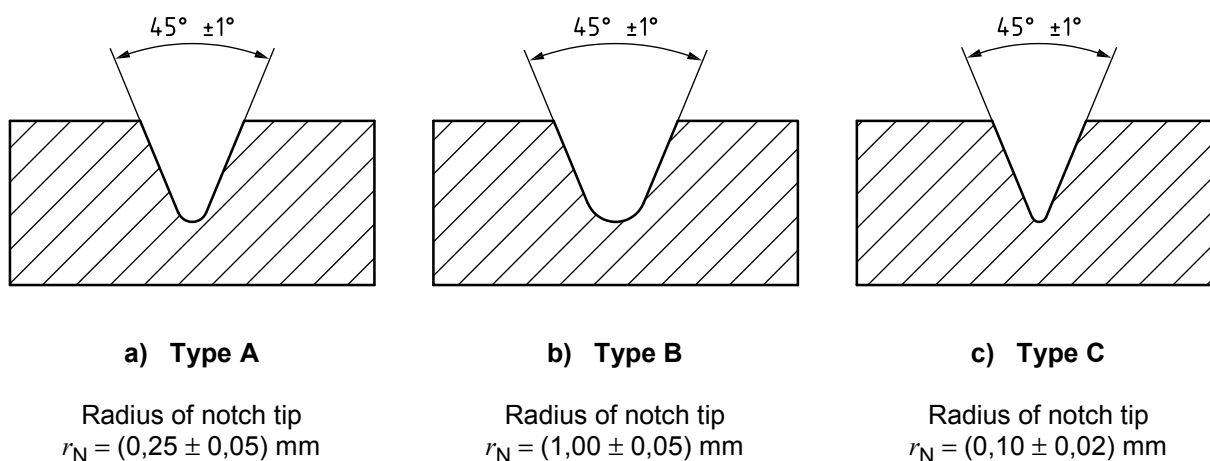

Figure 5 — Notch types

6.2 Anisotropy

Certain types of sheet or panel material or specimen taken from injection-moulded plates can show different impact properties, depending on the direction in the plane of the sheet or panel. In such cases, it is customary to cut groups of test specimens with their major axes respectively parallel and perpendicular to the direction of some feature of the sheet or panel which is either visible or inferred from knowledge of the method of manufacture.

6.3 Shape and dimensions

6.3.1 Materials not exhibiting interlaminar shear fracture

6.3.1.1 Moulding and extrusion compounds

6.3.1.1.1 Type 1 test specimens, unnotched or with one of three different types of notch, shall be used as specified in Tables 1 and 2 and shown in Figures 2 and 5. The notch shall be located at the centre of the specimen. Type 1 specimens (see Table 1) may be taken from the central part of the type A multipurpose test specimen specified in ISO 3167.

Table 1 — Specimen types, specimen dimensions and spans between specimen supports
(see Figures 2 and 6)

Dimensions in millimetres

Specimen type	Length ^a <i>l</i>	Width ^a <i>b</i>	Thickness ^a <i>h</i>	Span <i>L</i>
1	80 ± 2	10,0 ± 0,2	4,0 ± 0,2	62 ^{+0,5} _{-0,0}
2 ^b	25 <i>h</i>	10 or 15 ^c	3 ^d	20 <i>h</i>
3 ^b	11 <i>h</i> or 13 <i>h</i>			6 <i>h</i> or 8 <i>h</i>

^a The specimen dimensions (thickness, *h*, width, *b*, and length, *l*) are defined by $h < b < l$.

^b Specimen types 2 and 3 shall be used only for materials described in 6.3.2.

^c 10 mm for materials reinforced with a fine structure, 15 mm for those with a large stitch structure (see 6.3.2.2).

^d Preferred thickness. If the specimen is cut from a sheet or a piece, *h* shall be equal to the thickness of the sheet or piece, up to 10,2 mm (see 6.3.1.2)

**Table 2 — Method designations, specimen types, notch types and notch dimensions —
Materials not exhibiting interlaminar shear fracture**

Dimensions in millimetres

Method designation ^a	Specimen type	Blow direction	Notch type	Notch tip radius, <i>r_N</i> (see Figure 5)	Remaining width, <i>b_N</i> , at notch tip (see Figure 2)
ISO 179-1/1eA ^b	1	Edgewise	A	0,25 ± 0,05	8,0 ± 0,2
ISO 179-1/1eB			B	1,00 ± 0,05	8,0 ± 0,2
ISO 179-1/1eC			C	0,10 ± 0,02	8,0 ± 0,2
ISO 179-1/1eU ^b			Unnotched		
ISO 179-1/1fU ^c		Flatwise	Unnotched		

^a If specimens are taken from sheet or products, the thickness of the sheet or product shall be added to the designation. Unreinforced specimens shall not be tested with their machined surface under tension.

^b Preferred method.

^c Especially for the study of surface effects (see 6.3.1.1.3).

6.3.1.1.2 The preferred type of notch is type A (see Table 2 and Figure 5). For most materials, unnotched specimens or specimens with a single type A notch tested by edgewise impact (see 3.3) are suitable. If specimens with a type A notch do not break during the test, specimens with a type C notch shall be used. If information on the notch sensitivity of the material is desired, specimens with notch types A, B and C shall be tested.

6.3.1.1.3 Unnotched or double-notched specimens tested by flatwise impact (see 3.4) can be used to study surface effects (see 1.3 and Annex A).

6.3.1.2 Sheet materials

The recommended value of the thickness, h , is 4 mm. If the specimen is cut from a sheet or a piece taken from a structure, the thickness of the specimen, up to 10,2 mm, shall be the same as the thickness of the sheet or the structure.

Specimens taken from pieces thicker than 10,2 mm shall be machined to $(10 \pm 0,2)$ mm from one surface, provided that the sheet is homogeneous in its thickness and contains only one type of reinforcement uniformly distributed. If unnotched or double-notched specimens are tested by flatwise impact, the original surface shall be tested under tension.

6.3.2 Materials exhibiting interlaminar shear fracture (e.g. long-fibre-reinforced materials)

6.3.2.1 Unnotched specimens of type 2 or 3 are used. Apart from the thickness, the specimen dimensions are not specified. The most important parameter is the ratio of the span between the specimen supports to the specimen dimension in the direction of the blow (see Table 1).

Usually specimens are tested in the normal direction (see Figure 4).

6.3.2.2 "Flatwise normal" testing (see Figure 4): the width of specimen shall be 10 mm for materials reinforced with a fine structure (thin fabrics and parallel yarns) and 15 mm for materials reinforced with a large stitch structure (roving fabrics) or an irregularly manufactured structure.

6.3.2.3 "Edgewise parallel" testing (see Figure 4): when testing specimens in the parallel direction, the specimen dimension perpendicular to the blow direction shall be the thickness of the sheet from which the specimen was cut.

6.3.2.4 The length, l , of the specimen shall be chosen to give a span-to-thickness ratio, L/h , of 20 for type 2 specimens and 6 for type 3 specimens although, if the apparatus does not allow a ratio $L/h = 6$, a ratio $L/h = 8$ may be used, especially for thin sheets, as indicated in Table 1.

6.3.2.5 With type 2 specimens, tensile-type failure occurs; with type 3 specimens, interlaminar shear failure of the sheet usually occurs. The different types of failure which can occur are summarized in Table 3.





NOTE In some cases (thin-fabric reinforcement), shear failure does not occur. In the case of type 3 specimens, the fracture starts as a single or multiple shear failure and continues as tensile failure.

6.4 Number of test specimens

6.4.1 Unless otherwise specified in the standard for the material being tested, a set consisting of 10 specimens shall be tested. When the coefficient of variation (see ISO 2602) has a value of less than 5 %, a minimum number of five test specimens is sufficient.

6.4.2 If laminates are tested in the normal and parallel directions, 10 specimens shall be used for each direction.

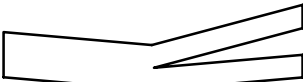
Table 3 — Method designation and specimen types — Materials exhibiting interlaminar shear fracture

Method designation	Specimen type	L/h	Type of failure	Schematic	
ISO 179-1/2 n or p ^a	2	20	Tension	t	
			Compression	c	
			Buckling	b	
ISO 179-1/3 n or p ^a	3	6 or 8	Shear	s	
			Multiple shear	ms	
			Shear followed by tensile fracture	st	

^a "n" is the normal direction and "p" is the parallel direction with respect to the sheet plane (see Figure 4).

6.5 Definition of span between specimen supports, L

The span between the specimen supports, L , is defined as the distance between the lines of contact of the specimen with the supports. Figure 6 shows the span, L , and a suitable way in which it can be calculated by measuring the radius of the supports and the distance between them.

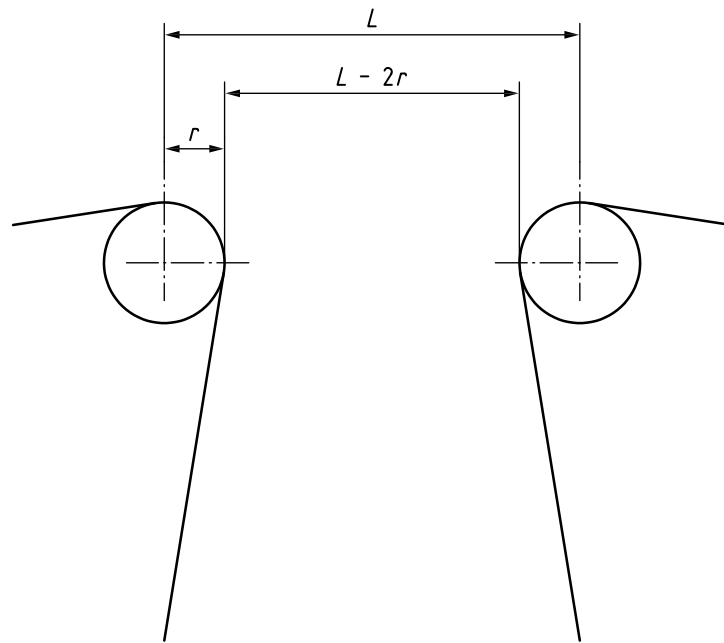

Figure 6 — Span, L , and suitable measurement position

6.6 Conditioning

Unless otherwise specified in the standard for the material under test, the specimens shall be conditioned for at least 16 h at $(23 \pm 2)^\circ\text{C}$ and $(50 \pm 5)\%$ relative humidity in accordance with ISO 291, unless other conditions are agreed upon by the interested parties. In the case of notched specimens, the conditioning time is after notching.

7 Procedure

7.1 Conduct the test in the same atmosphere as that used for conditioning, unless otherwise agreed upon by the interested parties, e.g. for testing at high or low temperatures.

7.2 Measure the thickness, h , and width, b , of each test specimen, in the centre, to the nearest 0,02 mm. In the case of notched specimens, carefully measure the remaining width, b_N , to the nearest 0,02 mm.

In the case of injection-moulded specimens, it is not necessary to measure the dimensions of each specimen. It is sufficient to measure one specimen from a set to make sure that the dimensions correspond to those in Table 1. With multiple-cavity moulds, ensure that the dimensions of the specimens are the same for each cavity.

Check the span between the specimen supports and adjust it, if necessary, in accordance with Table 1 and 6.5.

7.3 Check that the impact machine is able to perform the test with the specified velocity of impact and that it is in the correct range of absorbed energy, W , which shall be between 10 % and 80 % of the available energy at impact, E . If more than one of the pendulums conform to these requirements, the pendulum having the highest energy shall be used.

7.4 Determine the frictional losses and correct the absorbed energy in accordance with ISO 13802.

7.5 Lift the pendulum to the prescribed height and support it. Place the specimen on the supports in the machine in such a manner that the striking edge will hit the centre of the specimen. Carefully align notched specimens so that the centre of the notch is located directly in the plane of impact (see Figure 1, left).

7.6 Release the pendulum. Record the impact energy absorbed by the specimen and apply any necessary corrections for frictional losses, etc. (see 7.4).

7.7 For moulding and extrusion compounds, four types of failure, designated by the following code-letters, can occur:

- C complete break: a break in which the specimen separates into two or more pieces
- H hinge break: an incomplete break such that both parts of the specimen are held together only by a thin peripheral layer in the form of a hinge having low residual stiffness
- P partial break: an incomplete break that does not meet the definition for hinge break
- N non-break: there is no break, and the specimen is only distorted, possibly combined with stress whitening

8 Calculation and expression of results

8.1 Unnotched specimens

Calculate the Charpy impact strength of unnotched specimens, a_{cU} , expressed in kilojoules per square metre, using the following equation:

$$a_{cU} = \frac{E_c}{h \cdot b} \times 10^3 \quad (1)$$

where

E_c is the corrected energy, in joules, absorbed by breaking the test specimen;

h is the thickness, in millimetres, of the test specimen;

b is the width, in millimetres, of the test specimen.

8.2 Notched specimens

Calculate the Charpy impact strength of notched specimens, a_{cN} , expressed in kilojoules per square metre, with notches A, B or C, using the following equation:

$$a_{cN} = \frac{E_c}{h \cdot b_N} \times 10^3 \quad (2)$$

where

E_c is the corrected energy, in joules, absorbed by breaking the test specimen;

h is the thickness, in millimetres, of the test specimen;

b_N is the remaining width, in millimetres, of the test specimen.

8.3 Statistical parameters

Calculate as the test result the arithmetic mean of the individual test results and, if required, the standard deviation of the mean value, using the procedure given in ISO 2602. For each type of failure within one sample, the relevant numbers of specimens shall be given and mean values shall be calculated.

8.4 Significant figures

Report all calculated mean values to two significant figures.

9 Precision

See Annex B.

10 Test report

The test report shall include the following information:

- a) a reference to this part of ISO 179;
- b) the method used, designated in accordance with Table 2, e.g.:

Charpy impact test ISO 179-1/ 1 e A

Specimen type (see Table 1) _____

Direction of blow (see Figure 4) _____

Type of notch (see Figure 5) _____

or in accordance with Table 3, e.g.:

Charpy impact test ISO 179-1/ 2 n

Specimen type (see Table 1) _____

Direction of blow (see Figure 4) _____

- c) all information necessary for identification of the material tested, including type, source, manufacturer's code, grade and history, where these are known;
- d) a description of the nature and form of the material, i.e. whether a product, semifinished product, test plate or specimen, and including principal dimensions, shape, method of manufacture, etc., where these are known;
- e) the velocity of impact;
- f) the nominal pendulum energy;
- g) the method of test specimen preparation;
- h) if the material is in the form of a product or a semifinished product, the orientation of the test specimen in relation to the product or semifinished product from which it was cut;
- i) the number of specimens tested;
- j) the standard atmosphere used for conditioning and testing, plus any special conditioning treatment if required by the standard for the material or product;

- k) the type(s) of failure observed;
- l) the individual test results, presented as follows (see also Table 4):
 - 1) group the results according to the three basic types of failure:
 - C complete break, including hinge break H
 - P partial break
 - N non-break,
 - 2) select the most frequent type and record the mean value, x , of the impact strength as the test result for this type of failure, followed by the letter C or P for the type of failure,
 - 3) if the most frequent failure type is N, record the letter N only,
 - 4) add (between brackets) the letter C, P or N for the second most frequent failure type, but only if its frequency is higher than 1/3 (if not relevant, insert an asterisk);
- m) the standard deviations of the mean values, if required;
- n) the date(s) of testing.

Table 4 — Presentation of results

Type of failure			Designation
C	P	N	
x	*	*	$x\text{C}^*$
x	(P)	*	$x\text{C(P)}$
x	*	(N)	$x\text{C(N)}$
*	x	*	$x\text{P}^*$
(C)	x	*	$x\text{P(C)}$
*	x	(N)	$x\text{P(N)}$
*	*	N	N^*
(C)	*	N	N(C)
*	(P)	N	N(P)
x	Mean value of impact strength for most frequent failure type, excluding type N.		
C, P or N	Most frequent failure type.		
(C), (P) or (N)	Second most frequent failure type, to be recorded only if its frequency is higher than 1/3.		
*	Not relevant.		

Annex A (informative)

Additional methods for investigating the influence of surface effects

The following additional methods with double V-notches can be used for materials described in 6.3.1.

If the influence of surface effects on moderate- or high-impact materials is to be measured, flatwise impact may be used with double V-notches. Two notches are made perpendicular to the line of impact. The length of each notch is h , as shown in Figure A.1.

Table A.1 — Parameters for tests on double-notched specimens

Dimensions in millimetres

Method designation ^a	Specimen type	Blow direction	Notch type	Notch tip radius, r_N	Remaining width, b_N , at notch tip
			Double notch		
ISO 179-1/1fA	1	Flatwise	A	$0,25 \pm 0,05$	$6,0 \pm 0,2$
ISO 179-1/1fB	1	Flatwise	B	$1,00 \pm 0,05$	$6,0 \pm 0,2$
ISO 179-1/1fC	1	Flatwise	C	$0,10 \pm 0,02$	$6,0 \pm 0,2$
^a If specimens are taken from sheets or products, the thickness of the sheet or product shall be added to the designation.					

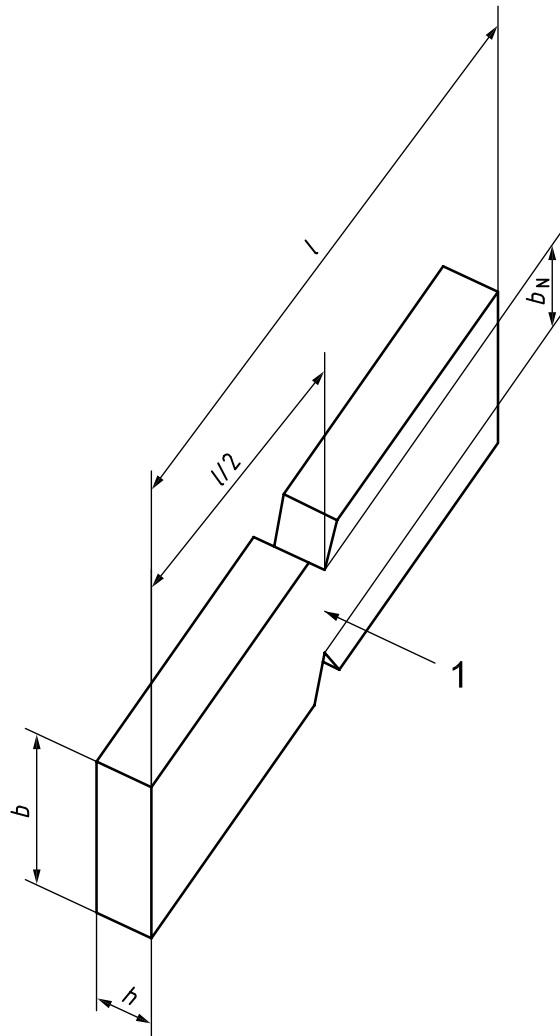

Key

1 direction of blow

Figure A.1 — Double-notched specimen

Annex B (informative)

Precision data

B.1 General

B.1.1 Tables B.1 and B.2 are based on round robins¹⁾ performed in accordance with ASTM E691. For each material, all the test bars were prepared by one source, except for notching. Notches were verified by the laboratory responsible for specimen distribution. Tables B.1 and B.2 are presented by analysis, day 1 and day 2. Each analysis is based on participating laboratories testing 10 specimens of each material. One specimen (determination) is a test result for calculating the statistics as per ASTM E691 statistical software.

B.1.2 Table B.1 is based on a round robin involving nine laboratories and three materials and Table B.2 is based on a round robin involving seven laboratories and two materials. The laboratories and materials were grouped by the required velocity (2,9 m/s or 3,8 m/s) due to the difficulty in finding laboratories that had the necessary pendulums to carry out testing at both velocities.

NOTE The following explanations of r and R (see Clause B.2) are only intended to present a meaningful way of considering the *approximate* precision of this test method. The data in Tables B.1 and B.2 are not intended to be rigorously applied to acceptance or rejection of material, as those data are specific to the round robin and might not be representative of other lots, conditions, materials or laboratories. Users of this test method are recommended to apply the principles of ASTM E691 to generate data specific to their laboratory and materials, or between specific laboratories. The principles of Clause B.2 would then be valid for such data.

B.2 Concept of r and R

If s_r and s_R have been calculated from a large enough body of data, and for test results that were from one test determination, then:

For the **repeatability**, r (comparing two test results for the same material, obtained by the same operator using the same equipment on the same day), the two test results should be judged not equivalent if they differ by more than the r -value for that material.

For the **reproducibility**, R (comparing two results for the same material, obtained by different operators using different equipment on different days), the two test results should be judged not equivalent if they differ by more than the R -value for that material.

Any judgment in accordance with the above would have an approximately 95 % (0,95) probability of being correct.

1) Supporting data are available from the Secretariat of TC 61/SC 2 at AENOR.

Table B.1 — Precision data for Charpy impact at 2,9 m/s

All values in kJ/m²

	Material	Average	s_r^a	s_R^b	r^c	R^d
Day 1	ABS	13,48	0,47	1,86	1,32	5,21
	GF-PBT	8,52	0,61	1,27	1,71	3,55
	Polypropylene	10,48	0,63	1,58	1,77	4,43
Day 2	ABS	13,44	0,45	1,90	1,25	5,31
	GF-PBT	8,54	0,60	1,29	1,68	3,62
	Polypropylene	10,80	0,65	1,45	1,82	4,06
<p>a s_r is the within-laboratory standard deviation.</p> <p>b s_R is the between-laboratory standard deviation.</p> <p>c $r = 2,83s_r$.</p> <p>d $R = 2,83s_R$.</p>						

Table B.2 — Precision data for Charpy impact at 3,8 m/s

All values in kJ/m²

	Material	Average	s_r^a	s_R^b	r^c	R^d
Day 1	Polycarbonate	91,69	5,30	8,37	14,85	23,43
	Polyurethane	94,33	5,37	6,21	15,03	17,38
Day 2	Polycarbonate	91,72	3,85	6,49	10,78	18,16
	Polyurethane	92,39	6,32	7,86	17,69	22,00
<p>a s_r is the within-laboratory standard deviation.</p> <p>b s_R is the between-laboratory standard deviation.</p> <p>c $r = 2,83s_r$.</p> <p>d $R = 2,83s_R$.</p>						

Annex C (informative)

Determining the notch tip radius using a CCD microscope

C.1 The Charpy test result is sometimes very sensitive to the radius of the notch tip. In such cases, it is necessary for the radius to be measured accurately. This annex illustrates the effect of notch tip radius on the Charpy impact strength and describes the CCD microscope method as a suitable way of measuring the notch radius.

C.2 Figure C.1 shows the effect of the notch radius on the Charpy impact strength of four types of plastics material.

C.3 Table C.1 compares three methods of determining the notch radius.

C.4 Figure C.2 shows a CCD microscope and a view of a typical notch. The notch radius can be determined from measurements at three points, using the following equations:

$$x^2 + y^2 + ax + by + c = 0$$

$$(x + a/2)^2 + (y + b/2)^2 = a^2/4 + b^2/4 - c$$

$$r_N = (a^2/4 + b^2/4 - c)^{1/2}$$

where

x and y are the x - and y -coordinates of a point;

a , b and c are constants;

r_N is the notch radius.

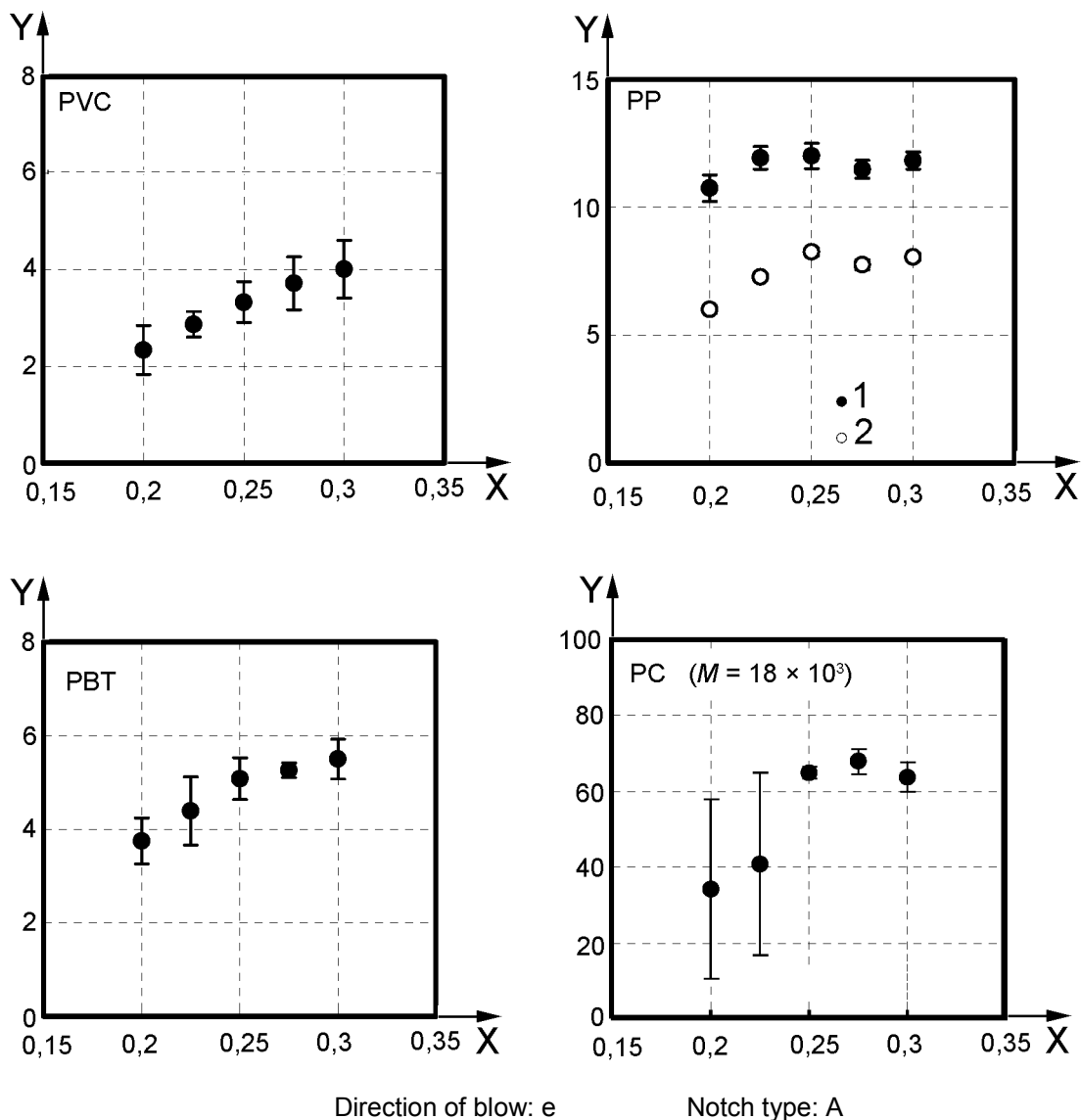

Key

- X notch tip radius (mm)
- Y impact strength (kJ/m²)
- 1 PP block copolymer
- 2 PP homopolymer

Figure C.1 — Effect of notch tip radius on Charpy impact strength

Table C.1 — Methods for determining the notch tip radius

Method	Principle	Determination	Procedure	Detection capability mm	Remarks
Digital-microscope method	Optical CCD microscope Simple, good precision	Digital	Notch profile obtained using CCD microscope (magnification $\times 100$ to $\times 600$). Radius calculated by digital processing (see Clause C.4).	1/1 000	Operation is quick and simple. Superior depth of field is beneficial for 3D image measurement.
Comparator method (ASTM D6110)	Optical comparison with template Indirect method, not simple	Comparison	Magnified image compared with a transparent template (prepared in advance) to determine whether notch tip radius falls within a specified range.	1/100	Method does not determine actual value of radius.
Stylus instrument method	Physical outline trace of notch with needle Simple but affected by vibration	Digital	Stylus used to explore surface of specimen and acquire notch profile. Radius calculated by digital processing.	1/1 000	Stylus is susceptible to vibration. Burr in notch can cause errors.

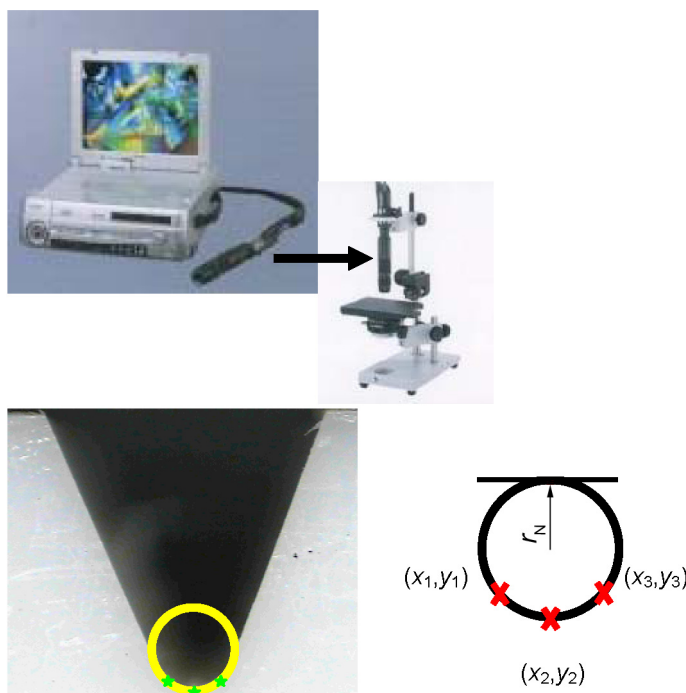

Figure C.2 — Typical CCD microscope and view of a typical notch

Bibliography

- [1] ISO 180, *Plastics — Determination of Izod impact strength*
- [2] ASTM E691, *Standard Practice for Conducting an Interlaboratory Study to Determine the Precision of a Test Method*
- [3] ASTM D6110, *Standard Test Method for Determining the Charpy Impact Resistance of Notched Specimens of Plastics*

ICS 83.080.01

Price based on 22 pages