

INTERNATIONAL STANDARD**142**

INTERNATIONAL ORGANIZATION FOR STANDARDIZATION • МЕЖДУНАРОДНАЯ ОРГАНИЗАЦИЯ ПО СТАНДАРТИЗАЦИИ • ORGANISATION INTERNATIONALE DE NORMALISATION

Textile machinery and accessories — Weaving preparatory machines — Definition of left and right sides*Matériel pour l'industrie textile — Machines de préparation pour le tissage — Définition des côtés droit et gauche*

First edition — 1976-10-15

UDC 677.054**Ref. No. ISO 142-1976 (E)****Descriptors :** textile machinery, weaving, preparation, warpers, quillers, winders, definitions, orientation, right side, left side.

Price based on 2 pages

FOREWORD

ISO (the International Organization for Standardization) is a worldwide federation of national standards institutes (ISO member bodies). The work of developing International Standards is carried out through ISO technical committees. Every member body interested in a subject for which a technical committee has been set up has the right to be represented on that committee. International organizations, governmental and non-governmental, in liaison with ISO, also take part in the work.

Draft International Standards adopted by the technical committees are circulated to the member bodies for approval before their acceptance as International Standards by the ISO Council.

Prior to 1972, the results of the work of the technical committees were published as ISO Recommendations; these documents are in the process of being transformed into International Standards. As part of this process, Technical Committee ISO/TC 72, *Textile machinery and accessories*, has reviewed ISO Recommendation R 142-1960 and found it technically suitable for transformation. International Standard ISO 142 therefore replaces ISO Recommendation R 142-1960, to which it is technically identical.

ISO Recommendation R 142 had been approved by the member bodies of the following countries :

Austria	Ireland	Romania
Belgium	Italy	Spain
Canada	Japan	Sweden
Chile	Netherlands	Switzerland
Denmark	New Zealand	United Kingdom
France	Norway	U.S.A.
Germany	Pakistan	U.S.S.R.
Greece	Poland	
India	Portugal	

No member body had expressed disapproval of the Recommendation.

The member bodies of the following countries disapproved the transformation of the Recommendation into an International Standard :

Belgium
France

Textile machinery and accessories – Weaving preparatory machines – Definition of left and right sides

1 SCOPE AND FIELD OF APPLICATION

This International Standard gives the definition of the left and right sides of weaving preparatory machines.

2 DEFINITION

To determine the side of weaving preparatory machines, the observer looks against the flow of material.

2.1 Warping machines

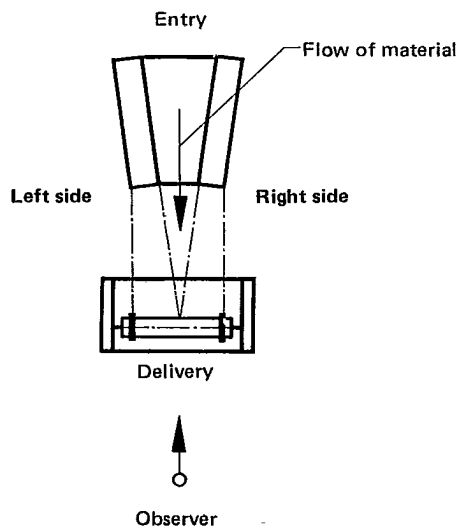

2.2 Sectional warping and beaming machines

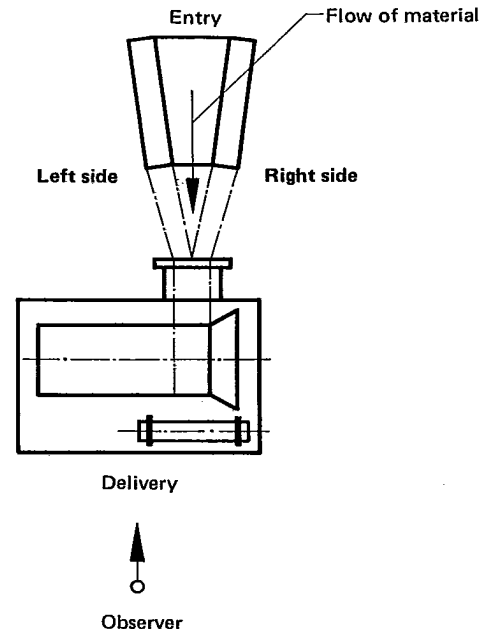

2.3 Warp sizing machine

