**Technical drawings — General
principles of presentation —**

**Part 24:
Lines on mechanical engineering
drawings**

*Dessins techniques — Principes généraux de représentation —
Partie 24: Traits utilisés pour les dessins industriels*



Reference number
ISO 128-24:2014(E)

© ISO 2014



COPYRIGHT PROTECTED DOCUMENT

© ISO 2014

All rights reserved. Unless otherwise specified, no part of this publication may be reproduced or utilized otherwise in any form or by any means, electronic or mechanical, including photocopying, or posting on the internet or an intranet, without prior written permission. Permission can be requested from either ISO at the address below or ISO's member body in the country of the requester.

ISO copyright office
Case postale 56 • CH-1211 Geneva 20
Tel. + 41 22 749 01 11
Fax + 41 22 749 09 47
E-mail copyright@iso.org
Web www.iso.org

Published in Switzerland

Contents

	Page
Foreword	iv
1 Scope	1
2 Normative references	1
3 General principles	2
4 Types of lines and their application	2
5 Line widths and line groups	4
Annex A (informative) Examples of application	5

Foreword

ISO (the International Organization for Standardization) is a worldwide federation of national standards bodies (ISO member bodies). The work of preparing International Standards is normally carried out through ISO technical committees. Each member body interested in a subject for which a technical committee has been established has the right to be represented on that committee. International organizations, governmental and non-governmental, in liaison with ISO, also take part in the work. ISO collaborates closely with the International Electrotechnical Commission (IEC) on all matters of electrotechnical standardization.

The procedures used to develop this document and those intended for its further maintenance are described in the ISO/IEC Directives, Part 1. In particular the different approval criteria needed for the different types of ISO documents should be noted. This document was drafted in accordance with the editorial rules of the ISO/IEC Directives, Part 2. www.iso.org/directives

Attention is drawn to the possibility that some of the elements of this document may be the subject of patent rights. ISO shall not be held responsible for identifying any or all such patent rights. Details of any patent rights identified during the development of the document will be in the Introduction and/or on the ISO list of patent declarations received. www.iso.org/patents

Any trade name used in this document is information given for the convenience of users and does not constitute an endorsement.

For an explanation on the meaning of ISO specific terms and expressions related to conformity assessment, as well as information about ISO's adherence to the WTO principles in the Technical Barriers to Trade (TBT) see the following URL: [Foreword - Supplementary information](#)

The committee responsible for this document is ISO/TC 10, *Technical product documentation*, Subcommittee SC 6, *Mechanical engineering documentation*.

This second edition cancels and replaces the first edition (ISO 128-24:1999), which has been technically revised.

ISO 128 consists of the following parts, under the general title *Technical drawings — General principles of presentation*:

- *Part 1: Introduction and index*
- *Part 15: Representation of shipbuilding drawings*
- *Part 20: Basic conventions for lines*
- *Part 21: Preparation of lines by CAD systems*
- *Part 22: Basic conventions and applications for leader lines and reference lines*
- *Part 23: Lines on construction drawings*
- *Part 24: Lines on mechanical engineering drawings*
- *Part 25: Lines on shipbuilding drawings*
- *Part 30: Basic conventions for views*
- *Part 34: Views on mechanical engineering drawings*
- *Part 40: Basic conventions for cuts and sections*
- *Part 44: Sections on mechanical engineering drawings*
- *Part 50: Basic conventions for representing areas on cuts and sections*

— *Part 71: Simplified representation for mechanical engineering drawings* [TS]

.....

Technical drawings — General principles of presentation —

Part 24: Lines on mechanical engineering drawings

1 Scope

This part of ISO 128 specifies general rules and basic conventions for the types of lines on mechanical engineering drawings.

2 Normative references

The following documents, in whole or in part, are normatively referenced in this document and are indispensable for its application. For dated references, only the edition cited applies. For undated references, the latest edition of the referenced document (including any amendments) applies.

ISO 128-20:1996, *Technical drawings — General principles of presentation — Part 20: Basic conventions for lines*

ISO 128-22:1999, *Technical drawings — General principles of presentation — Part 22: Basic conventions and applications for leader lines and reference lines*

ISO 128-30:2001, *Technical drawings — General principles of presentation — Part 30: Basic conventions for views*

ISO 128-40:2001, *Technical drawings — General principles of presentation — Part 40: Basic conventions for cuts and sections*

ISO 128-50:2001, *Technical drawings — General principles of presentation — Part 50: Basic conventions for representing areas on cuts and sections*

ISO 129-1, *Technical drawings — Indication of dimensions and tolerances — Part 1: General principles*

ISO 1101:2012, *Geometrical product specifications (GPS) — Geometrical tolerancing — Tolerances of form, orientation, location and run-out*

ISO 2203:1973, *Technical drawings — Conventional representation of gears*

ISO 3040:2009, *Geometrical product specifications (GPS) — Dimensioning and tolerancing — Cones*

ISO 5261:1995, *Technical drawings — Simplified representation of bars and profile sections*

ISO 6410-1:1993, *Technical drawings — Screw threads and threaded parts — Part 1: General conventions*

ISO 6428:1982, *Technical drawings — Requirements for microcopying*

ISO 10135:2007, *Geometrical product specifications (GPS) — Drawing indications for moulded parts in technical product documentation (TPD)*

ISO 10110-1:2006, *Optics and photonics — Preparation of drawings for optical elements and systems — Part 1: General*

ISO 15787:—¹⁾, *Technical product documentation — Heat-treated ferrous parts — Presentation and indications*

3 General principles

The basic types of lines, their designations and dimensions as well as general rules for draughting of lines are specified in ISO 128-20.

Requirements for microcopying are specified in ISO 6428.

4 Types of lines and their application

The first part of the line number in [Table 1](#) is the number of the basic type in accordance with ISO 128-20.

Table 1 — Types of lines and applications

No.	Line description and representation	Application		Reference	
01.1	Continuous narrow line 	.1	imaginary lines of intersection	—	
		.2	dimension lines	ISO 129-1	
		.3	extension lines	ISO 129-1	
		.4	leader lines and reference lines	ISO 128-22	
		.5	hatching	ISO 128-50	
		.6	outlines of revolved sections	ISO 128-40	
		.7	short centre lines	—	
		.8	root of screw threads	ISO 6410-1	
		.9	origin and terminations of dimension lines	ISO 129-1	
		.10	diagonals for the indication of flat surfaces	—	
		.11	bending lines on blanks and processed parts	—	
		.12	framing of details	—	
		.13	indication of repetitive details	—	
		.14	dimensioning and tolerancing lines for cones	ISO 3040	
		.15	location of laminations	—	
		.16	projection lines	—	
		.17	grid lines	—	
		Continuous narrow freehand line 	.18	preferably manually represented termination of partial or interrupted views, cuts and sections, if the limit is not a line of symmetry or a centre line ^a	—
		Continuous narrow line with zigzags 	.19	mechanically represented termination of partial or interrupted views, cuts and sections, if the limit is not a line of symmetry or a centre line ^a	—

^a It is recommended to use only one type of line on one drawing.

1) To be published. (Revision of ISO 15787:2001)

Table 1 (continued)

No.	Line description and representation	Application		Reference
01.2	Continuous wide line —————	.1	visible edges	ISO 128-30
		.2	visible outlines	ISO 128-30
		.3	crests of screw threads	ISO 6410-1
		.4	limit of length of full depth thread	ISO 6410-1
		.5	main representations in diagrams, maps, flow charts	—
		.6	system lines (structural metal engineering)	ISO 5261
		.7	parting lines of moulds in views	ISO 10135
		.8	direction changes of lines of cuts and section arrows	ISO 128-40
02.1	Dashed narrow line -----	.1	hidden edges	ISO 128-30
		.2	hidden outlines	ISO 128-30
02.2	Dashed wide line -----	.1	indication of permissible areas of surface treatment, e.g. heat treatment	ISO 15787
04.1	Long-dashed dotted narrow line - - - - -	.1	centre lines	—
		.2	lines and planes of symmetry	—
		.3	pitch circle of gears	ISO 2203
		.4	pitch circle of holes	—
		.5	indication of expected or wished spread of surface-hardened areas, e.g. heat treatment	ISO 15787
		.6	cutting line	ISO 128-40
04.2	Long-dashed dotted wide line - - - - -	.1	indication of (limited) required areas of surface treatment, e.g. heat treatment, restricted tolerated feature	ISO 15787 ISO 1101
		.2	position of cutting planes	ISO 128-40
05.1	Long-dashed double-dotted narrow line - -	.1	outlines of adjacent parts	—
		.2	extreme positions of movable parts	—
		.3	centroidal lines	—
		.4	initial outlines prior to forming	—
		.5	parts situated in front of a cutting plane	—
		.6	outlines of alternative executions	—
		.7	outlines of the finished part within blanks	ISO 10135
		.8	framing of particular fields/areas	ISO 15787
		.9	projected tolerance zone	ISO 1101
		.10	optical axes	ISO 10110-1
		.11	indication of structural outlines used in mechanical processes	ISO 15787
07.2	Dotted wide line1	indication of areas where heat treatment is not permissible	ISO 15787

^a It is recommended to use only one type of line on one drawing.

Examples of applications are given in [Annex A](#).

5 Line widths and line groups

On mechanical engineering drawings, two line widths are normally used. The proportions between the line widths should be 1:2.

The line groups are specified as shown in [Table 2](#).

Table 2 — Line groups

Dimensions in millimetres

Line group	Line widths for line no.	
	01.2 – 02.2 – 04.2	01.1 – 02.1 – 04.1 – 05.1
0,25	0,25	0,13
0,35	0,35	0,18
0,5 ^a	0,5	0,25
0,7 ^a	0,7	0,35
1	1	0,5
1,4	1,4	0,7
2	2	1

^a Preferred line groups

The widths and groups of lines should be chosen according to the type, size and scale of the drawing and according to the requirements for microcopying and/or other methods of reproduction.

Annex A (informative)

Examples of application

[Table A.1](#) gives examples of the application of the different types of lines indicating the reference number given in [Table 1](#). The figures are shown in first angle projection. It is understood that third angle projection could be used as well.

Table A.1 — Examples of application

01.1	Continuous narrow line
01.1.1	<p style="text-align: center;">Imaginary lines of intersection</p> 
01.1.2	<p style="text-align: center;">Dimension lines</p> 
01.1.3	<p style="text-align: center;">Extension lines</p> 
01.1.4	<p style="text-align: center;">Leader lines and reference lines</p> 
01.1.5	<p style="text-align: center;">Hatching</p> 

Table A.1 (continued)

01.1.6	<p>Outlines of revolved sections</p> 
01.1.7	<p>Short centre lines</p> 
01.1.8	<p>Root of screw threads</p> 
01.1.9	<p>Origin and terminations of dimension lines</p> 
01.1.10	<p>Diagonals for the indication of flat surfaces</p> 
01.1.11	<p>Bending lines on blanks and processed parts</p> 
01.1.12	<p>Framing of details</p> 

Table A.1 (continued)

<p>01.1.13</p>	<p>Indication of repetitive details, e.g. root diameters of gears</p> 
<p>01.1.14</p>	<p>Dimensioning and tolerancing lines for cones</p> 
<p>01.1.15</p>	<p>Location of laminations, e.g. transformer plates</p> 
<p>01.1.16</p>	<p>Projection lines</p> 
<p>01.1.17</p>	<p>Grid lines</p> 
<p>01.1.18</p>	<p>Continuous narrow freehand lines</p> 

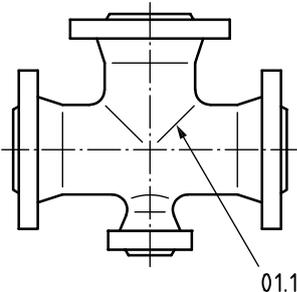
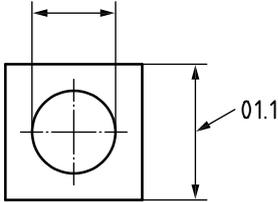
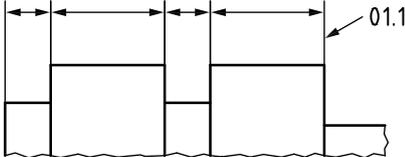
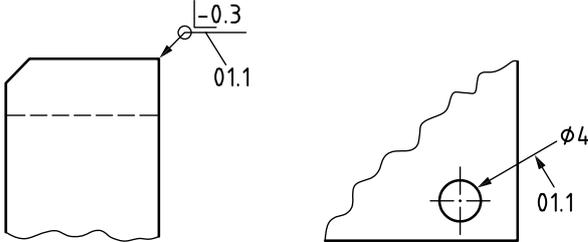
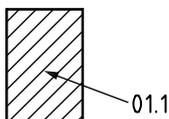
Table A.1 (continued)

01.1.19	<p>Continuous narrow lines with zigzags</p> 
01.2	<p>Continuous wide line</p>
01.2.1	<p>Visible edges</p> 
01.2.2	<p>Visible outlines</p> 
01.2.3	<p>Crests of screw threads</p> 
01.2.4	<p>Limit of length of full-depth thread</p> 
01.2.5	<p>Main representations in diagrams, maps, flow charts</p> 

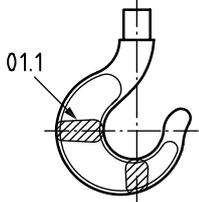
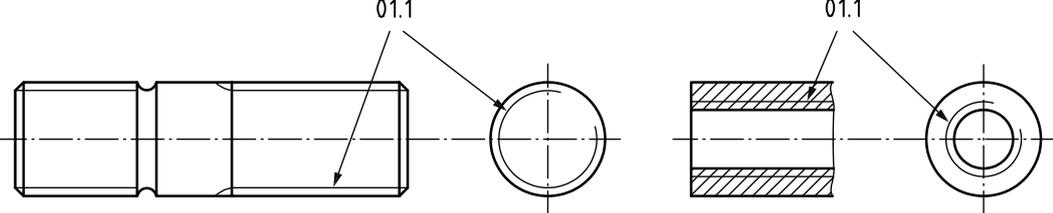
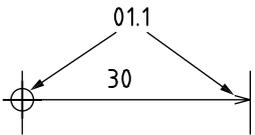
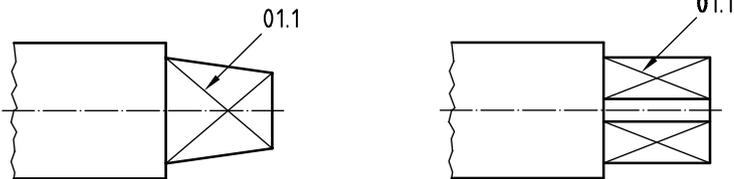
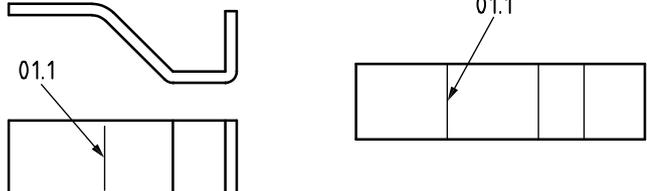
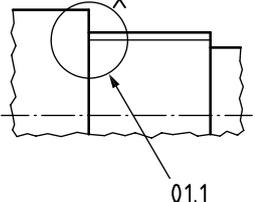
Table A.1 (continued)

<p>01.2.6</p>	<p>System lines</p>
<p>01.2.7</p>	<p>Parting lines of moulds in views</p>
<p>01.2.8</p>	<p>Direction changes of lines of cuts and section arrows</p>

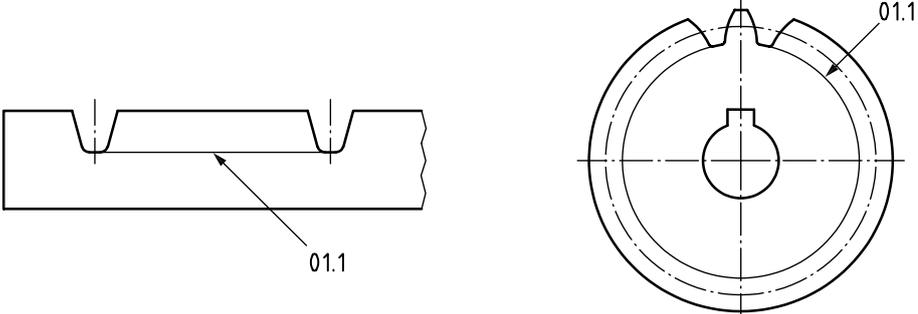
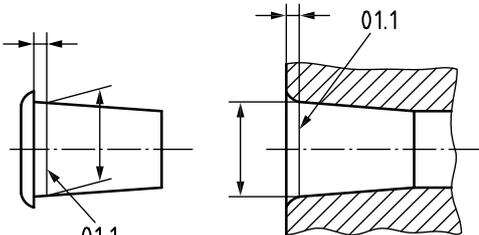
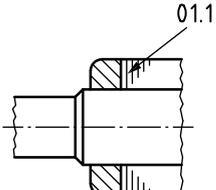
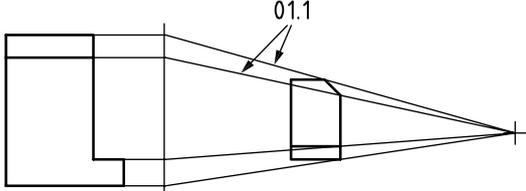
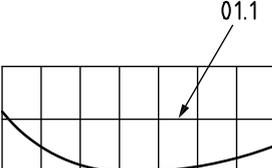
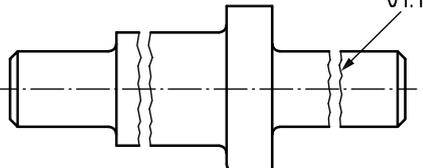
Table A.1 (continued)

<p>02.1</p>	<p>Dashed narrow line</p>
<p>02.1.1</p>	<p>Hidden edges</p> 
<p>02.1.2</p>	<p>Hidden outlines</p> 
<p>02.2</p>	<p>Dashed wide line</p>
<p>02.2.1</p>	<p>Indication of the permissible surface treatment, e.g. heat treatment</p> 
<p>04.1</p>	<p>Long-dashed dotted narrow line</p>
<p>04.1.1</p>	<p>Centre lines</p> 
<p>04.1.2</p>	<p>Lines and planes of symmetry</p> 

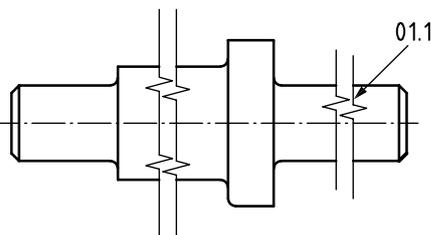
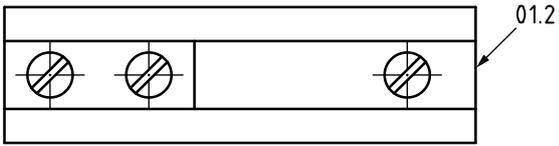
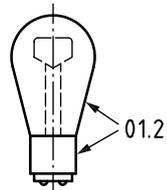
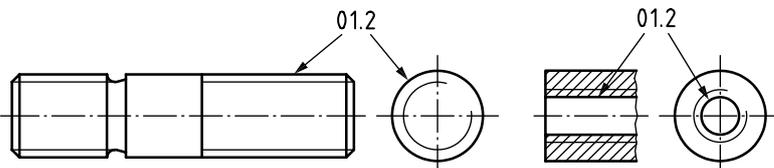
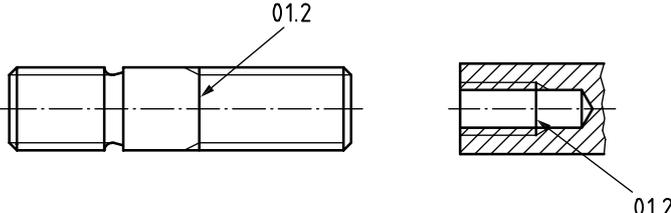
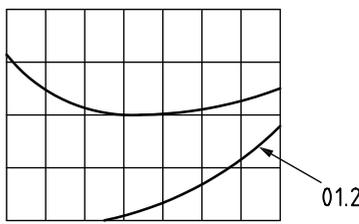
Table A.1 (continued)

<p>04.1.3</p>	<p>Pitch circles of gears</p> 
<p>04.1.4</p>	<p>Pitch circles of holes</p> 
<p>04.1.5</p>	<p>Indication of expected or wished spread of surface-hardened areas, e.g. heat treatment</p> 
<p>04.1.6</p>	<p>Cutting line</p> 

Table A.1 (continued)

<p>04.2</p>	<p>Long-dashed dotted wide line</p>
<p>04.2.1</p>	<p>Indication of the limited areas (heat treatment, measuring area, restricted toleranced feature)</p>  
<p>04.2.2</p>	<p>Position of cutting planes</p> 
<p>05.1</p>	<p>Long dashed double-dotted narrow line</p>
<p>05.1.1</p>	<p>Outlines of adjacent parts</p> 

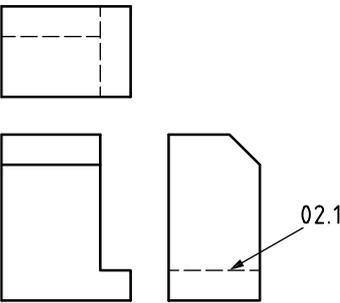
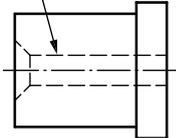
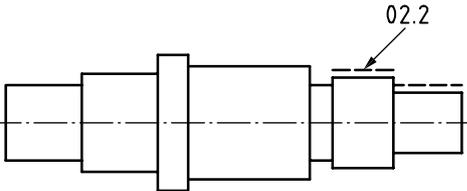
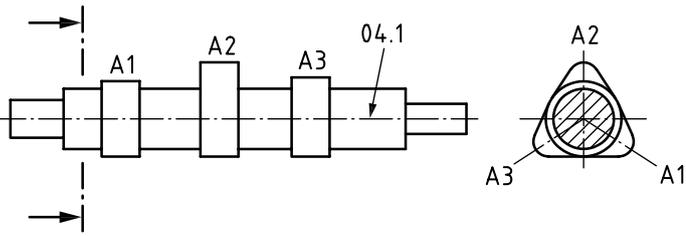
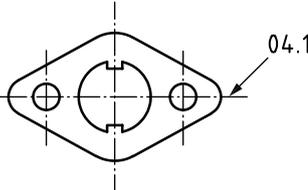
Table A.1 (continued)

<p>05.1.2</p>	<p>Extreme positions of movable parts</p> 
<p>05.1.3</p>	<p>Centroidal lines</p> 
<p>05.1.4</p>	<p>Initial outlines prior to forming</p> 
<p>05.1.5</p>	<p>Parts situated in front of a cutting plane</p> 
<p>05.1.6</p>	<p>Outlines of alternative executions</p> 

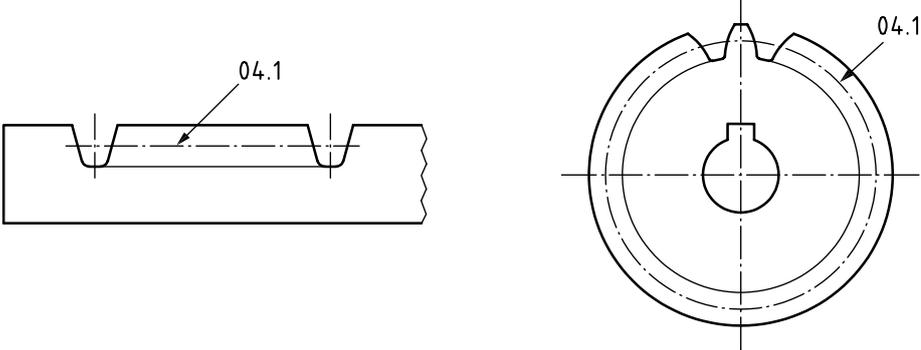
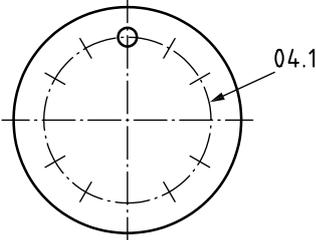
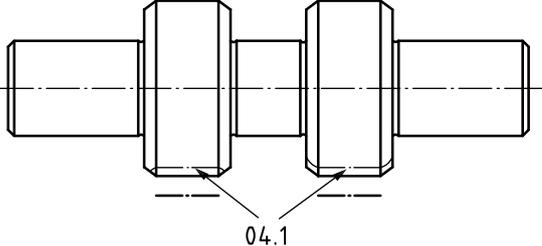
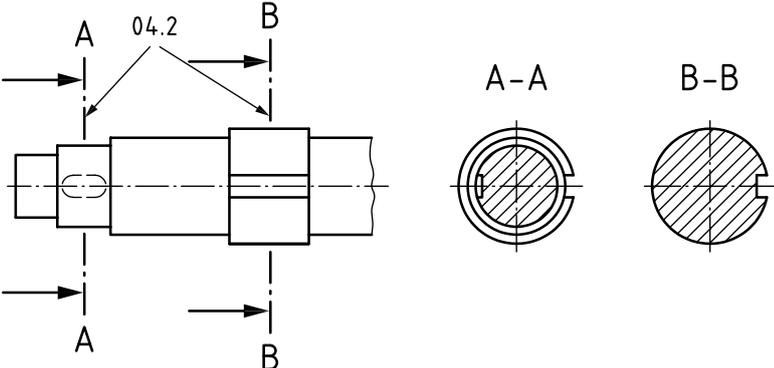
Table A.1 (continued)

<p>05.1.7</p>	<p>Outlines of the finished part within blanks</p> 
<p>05.1.8</p>	<p>Framings of particular fields/areas</p> 
<p>05.1.9</p>	<p>Projected tolerance zone</p> 
<p>05.1.10</p>	<p>Optical axis</p> 
<p>05.1.11</p>	<p>Indication of structural outlines used in mechanical processes</p> 

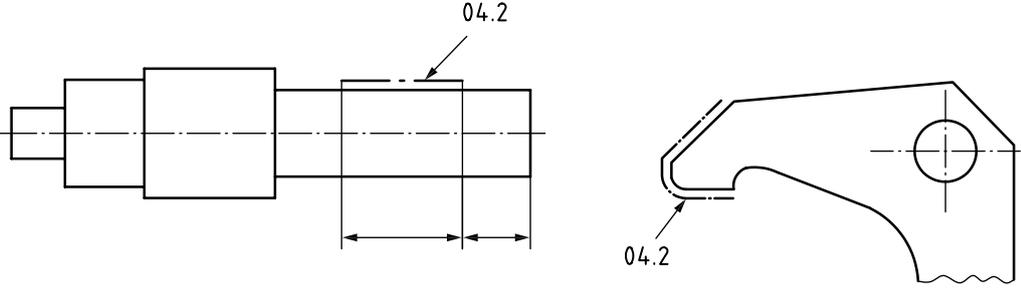
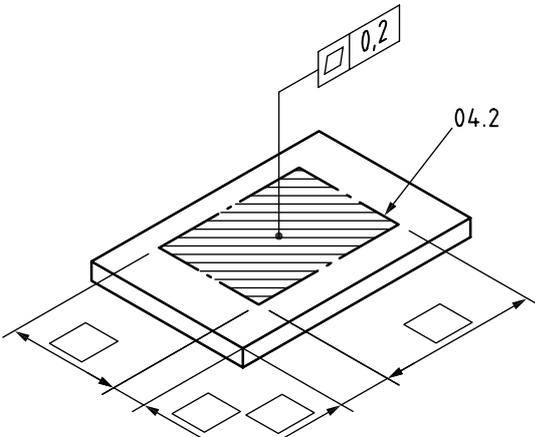
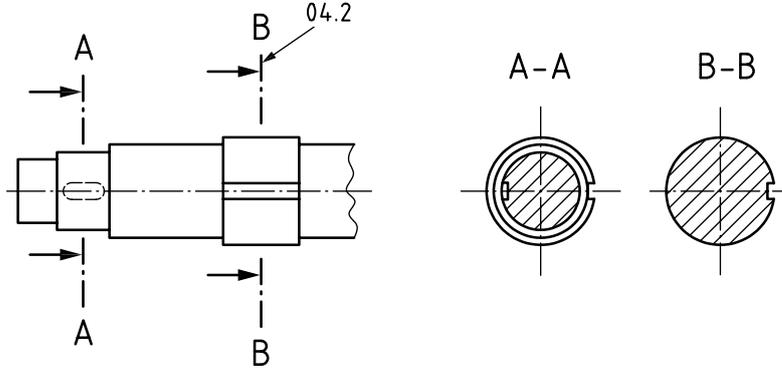
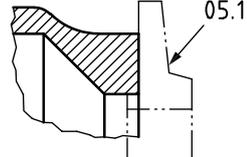
Table A.1 (continued)

07.2	Dotted wide line
07.2	<p data-bbox="598 324 1284 358">Indication of areas where heat treatment is not permissible</p>  <p data-bbox="885 369 933 392">07.2</p> <p>The diagram shows a shaft with a hole on the left and a cross-section on the right. A dotted wide line encloses the left portion of the shaft, with an arrow pointing to it from the label '07.2'.</p>

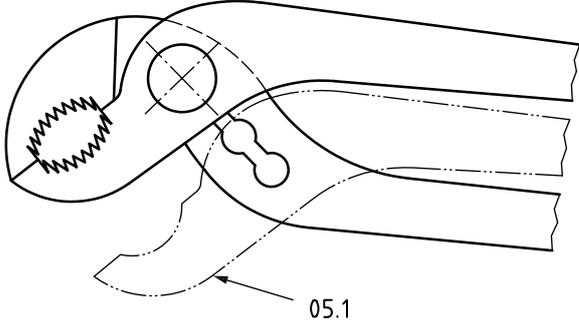
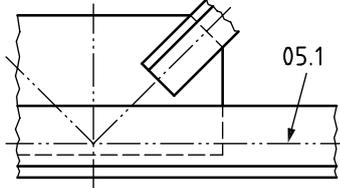
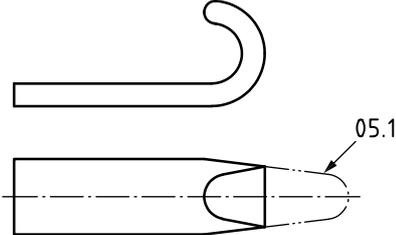
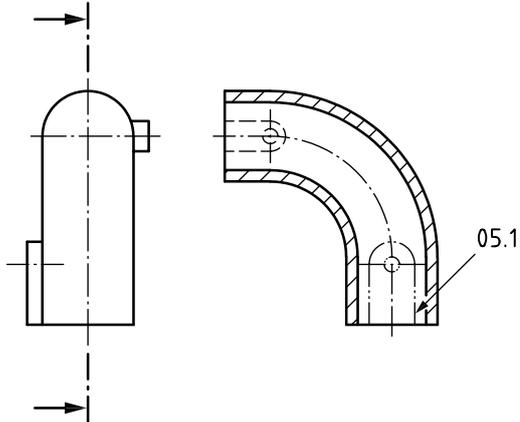
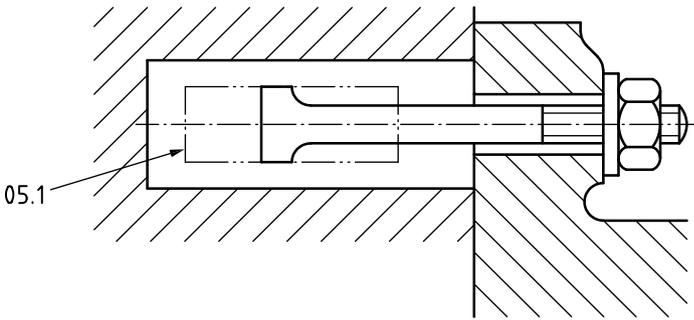
07.2

ICS 01.100.20

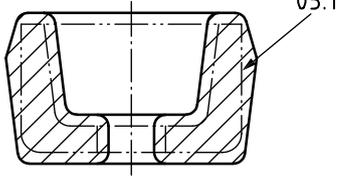
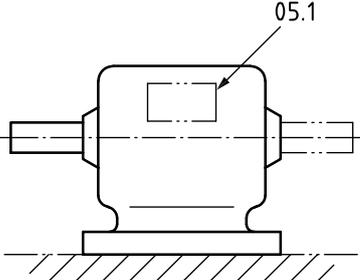
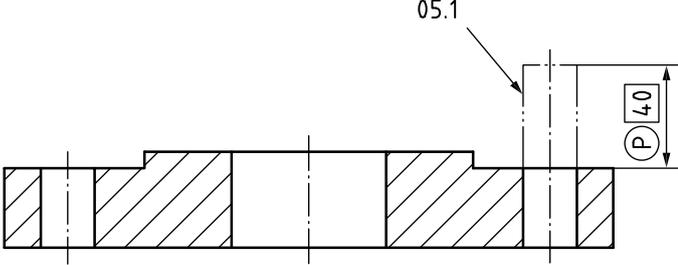
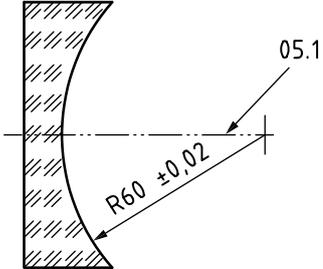
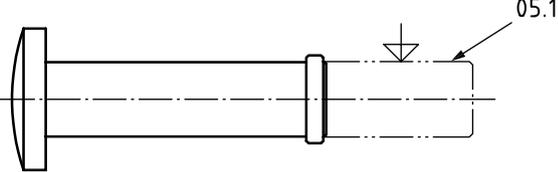
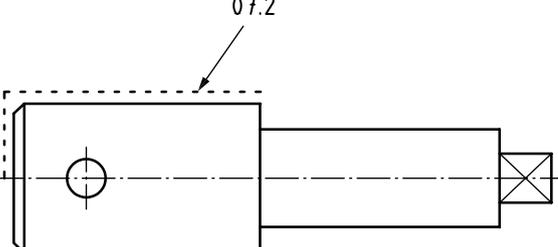
Price based on 15 pages

© ISO 2014 – All rights reserved