



INTERNATIONAL ORGANIZATION FOR STANDARDIZATION • МЕЖДУНАРОДНАЯ ОРГАНИЗАЦИЯ ПО СТАНДАРТИЗАЦИИ • ORGANISATION INTERNATIONALE DE NORMALISATION

Technical drawings — General principles of presentation

Dessins techniques — Principes généraux de représentation

First edition — 1982-07-01

UDC 744.4

Ref. No. ISO 128-1982 (E)

Descriptors : technical drawings, graphic symbols, generalities.

Foreword

ISO (the International Organization for Standardization) is a worldwide federation of national standards institutes (ISO member bodies). The work of developing International Standards is carried out through ISO technical committees. Every member body interested in a subject for which a technical committee has been set up has the right to be represented on that committee. International organizations, governmental and non-governmental, in liaison with ISO, also take part in the work.

Draft International Standards adopted by the technical committees are circulated to the member bodies for approval before their acceptance as International Standards by the ISO Council.

International Standard ISO 128 was developed by Technical Committee ISO/TC 10, *Technical drawings*, and was circulated to the member bodies in April 1980.

It has been approved by the member bodies of the following countries :

Australia	France	Norway
Belgium	Greece	Poland
Brazil	India	Romania
Canada	Italy	South Africa, Rep. of
China	Japan	Spain
Czechoslovakia	Korea, Rep. of	Sweden
Egypt, Arab Rep. of	Mexico	USSR
Finland	Netherlands	

The member bodies of the following countries expressed disapproval of the document on technical grounds :

Austria
Denmark
Germany, F.R.
Switzerland
United Kingdom
USA

This International Standard together with ISO 6410-1981 cancels and replaces ISO Recommendation R 128-1959 of which it constitutes a technical revision.

Contents

	Page
1 Scope and field of application	1
2 Views	1
3 Lines	4
4 Sections.....	7
5 Other conventions	11

Technical drawings – General principles of presentation

1 Scope and field of application

This International Standard specifies the general principles of presentation to be applied to technical drawings following the orthographic projection methods.

Additional International Standards are under preparation for other methods of representation.

This International Standard is intended for all kinds of technical drawings (mechanical, electrical, architectural, civil engineering, etc.). However, it is recognized that in some specific technical areas the general rules and conventions cannot adequately cover all the needs of specialized practices, and that additional rules are required which may be specified in separate standards. For these areas the general principles should however, be respected in order to facilitate international exchange of drawings and to ensure the coherence of drawings in a comprehensive system relating to several technical functions.

Attention has been given in this International Standard to the requirements of reproduction, including microcopying.

2 Views

2.1 Designation of views

View in direction a = View from the front

View in direction b = View from above

View in direction c = View from the left

View in direction d = View from the right

View in direction e = View from below

View in direction f = View from the rear

The front view (principal view) having been chosen (see 2.4), the other customary views make with it and between themselves angles of 90° or multiples of 90° (see figure 1).

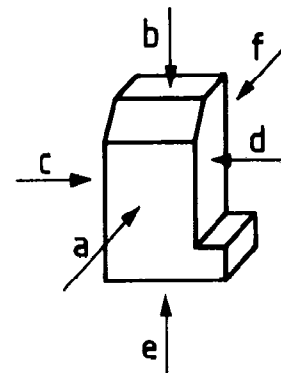

Figure 1

2.2 Relative position of views

Two alternative orthographic projection methods, of equal standing, can be used :

- the first angle projection method (formerly referred to as method E),
- the third angle projection method (formerly referred to as method A).

NOTES

1 For uniformity among the figures given throughout this International Standard, as examples, the relative positions of views are those provided by the first angle projection method. It should be understood, however, that each of the two methods could equally have been used without prejudice to the principle established.

2 The figures shown are not intended as design examples and are depicted in the simplest form to illustrate the text.

2.2.1 First angle projection method

With reference to the front view (a), the other views are arranged as follows (see figure 2) :

The view from above (b), is placed underneath

The view from below (e), is placed above

The view from the left (c), is placed on the right

The view from the right (d), is placed on the left

The view from the rear (f) may be placed on the left, or on the right, as convenient.

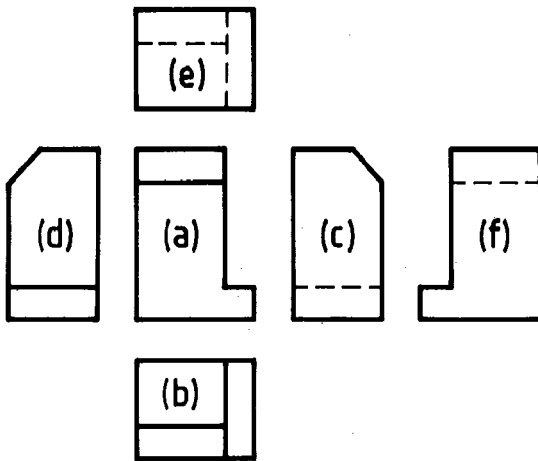

Figure 2

The distinguishing symbol of this method is shown in figure 3.



Figure 3

2.2.2 Third angle projection method

With reference to the front view (a), the other views are arranged as follows (see figure 4) :

The view from above (b), is placed above

The view from below (e), is placed underneath

The view from the left (c), is placed on the left

The view from the right (d), is placed on the right

The view from the rear (f) may be placed on the left, or on the right, as convenient.

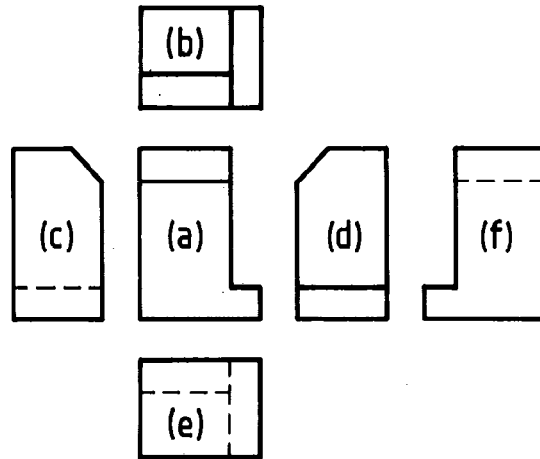

Figure 4

The distinguishing symbol of this method is shown in figure 5.



Figure 5

2.2.3 Layout of views using reference arrows

In those cases where it is an advantage to position the views not according to the strict pattern of the first or the third angle projection methods, the use of reference arrows permits the various views to be freely positioned.

With the exception of the principal view, each view shall be identified by a capital letter which is repeated near the arrow needed to indicate the direction of viewing for the relevant view.

The designated views may be located irrespective of the principal view. The capital letters identifying the referenced views shall be placed either immediately below or above the relevant views. In any one drawing the references shall be placed in the same way. No other indication is necessary (see figure 6).

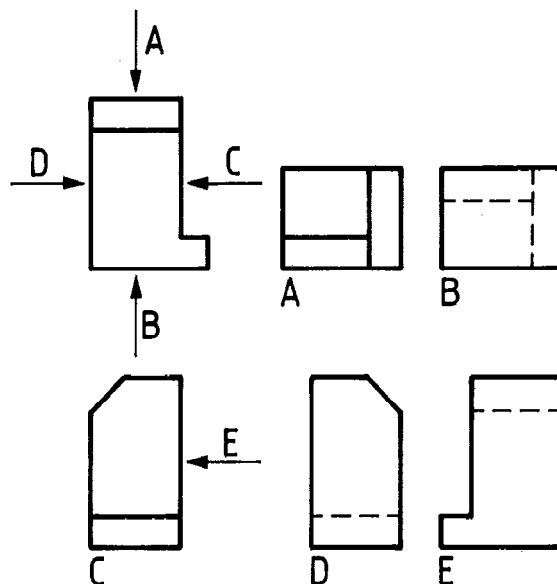

Figure 6

2.3 Indication of method

Where one of the methods specified in 2.2.1 and 2.2.2 is being used, the said method must be indicated on the drawing by means of its distinguishing symbol as shown in figures 3 or 5.

The symbol shall be placed in a space provided for the purpose in the title block of the drawing.

For the layout of views using reference arrows specified in 2.2.3, no distinguishing symbol is required.

2.4 Choice of views

The most informative view of an object shall be used as the front or principal view. Generally, this view shows the part in the functioning position. Parts which can be used in any position should preferably be drawn in the main position of manufacturing or mounting.

When other views (including sections) are needed, these shall be selected according to the following principles :

- to limit the number of views and sections to the minimum necessary and sufficient to fully delineate the object without ambiguity;
- to avoid the need for hidden outlines and edges;
- to avoid unnecessary repetition of detail.

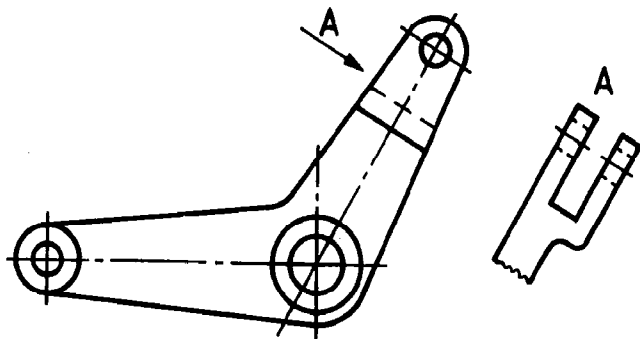

Figure 7

2.5 Special views

If a direction of viewing different from those shown in 2.1 is necessary, or if a view cannot be placed in its correct position using the methods shown in 2.2.1 and 2.2.2, reference arrows as indicated in 2.2.3 shall be used for the relevant view (see figures 7 and 8).

Whatever the direction of viewing, the capital letters referencing the views shall always be positioned normal to the direction of reading.

2.6 Partial views

Partial views may be used where complete views would not improve the information to be given. The partial view shall be cut off by a continuous thin freehand line (type C) or straight lines with zigzags (type D) (see figures 7, 9, 10 and others).

2.7 Local views

Provided that the presentation is unambiguous, it is permitted to give a local view instead of a complete view for symmetrical items. The local view should be drawn in third angle projection, regardless of the arrangement used for the general execution of the drawing.

Local views shall be drawn with continuous thick lines (type A), and shall be connected to the principal view by a centre line (type G). Examples of local views are shown in the figures 41, 42, 43 and 44.

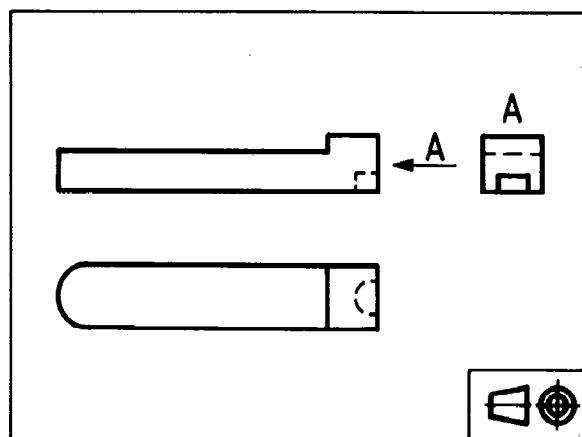

Figure 8

3 Lines









3.1 Types of lines

Only the types and thicknesses of line shown in the following table shall be used.

In cases where other types or thicknesses of line are used for special fields (for example electrical or pipe-work diagrams), or if the lines specified in the table are used for applications other than those detailed in the last column of the table, the conventions adopted must be indicated in other International Standards or explained by notes on the drawing concerned.

Typical applications of different types of lines are shown in figures 9 and 10.

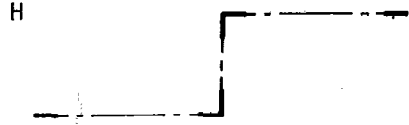
Table

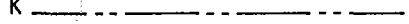
Line	Description	General applications See figures 9, 10 and other relevant figures
A 	Continuous thick	A1 Visible outlines A2 Visible edges
B 	Continuous thin (straight or curved)	B1 Imaginary lines of intersection B2 Dimension lines B3 Projection lines B4 Leader lines B5 Hatching B6 Outlines of revolved sections in place B7 Short centre lines
C 	Continuous thin freehand ²⁾	C1 Limits of partial or interrupted views and sections, if the limit is not a chain thin line (see figures 53 and 54)
D1 	Continuous thin (straight) with zigzags	D1
E 	Dashed thick ²⁾	E1 Hidden outlines E2 Hidden edges
F 	Dashed thin	F1 Hidden outlines F2 Hidden edges
G 	Chain thin	G1 Centre lines G2 Lines of symmetry G3 Trajectories
H 	Chain thin, thick at ends and changes of direction	H1 Cutting planes
J 	Chain thick	J1 Indication of lines or surfaces to which a special requirement applies
K 	Chain thin double-dashed	K1 Outlines of adjacent parts K2 Alternative and extreme positions of movable parts K3 Centroidal lines K4 Initial outlines prior to forming (see figure 58) K5 Parts situated in front of the cutting plane (see figure 48)

1) This type of line is suited for production of drawings by machines.

2) Although two alternatives are available, it is recommended that on any one drawing, only one type of line be used.

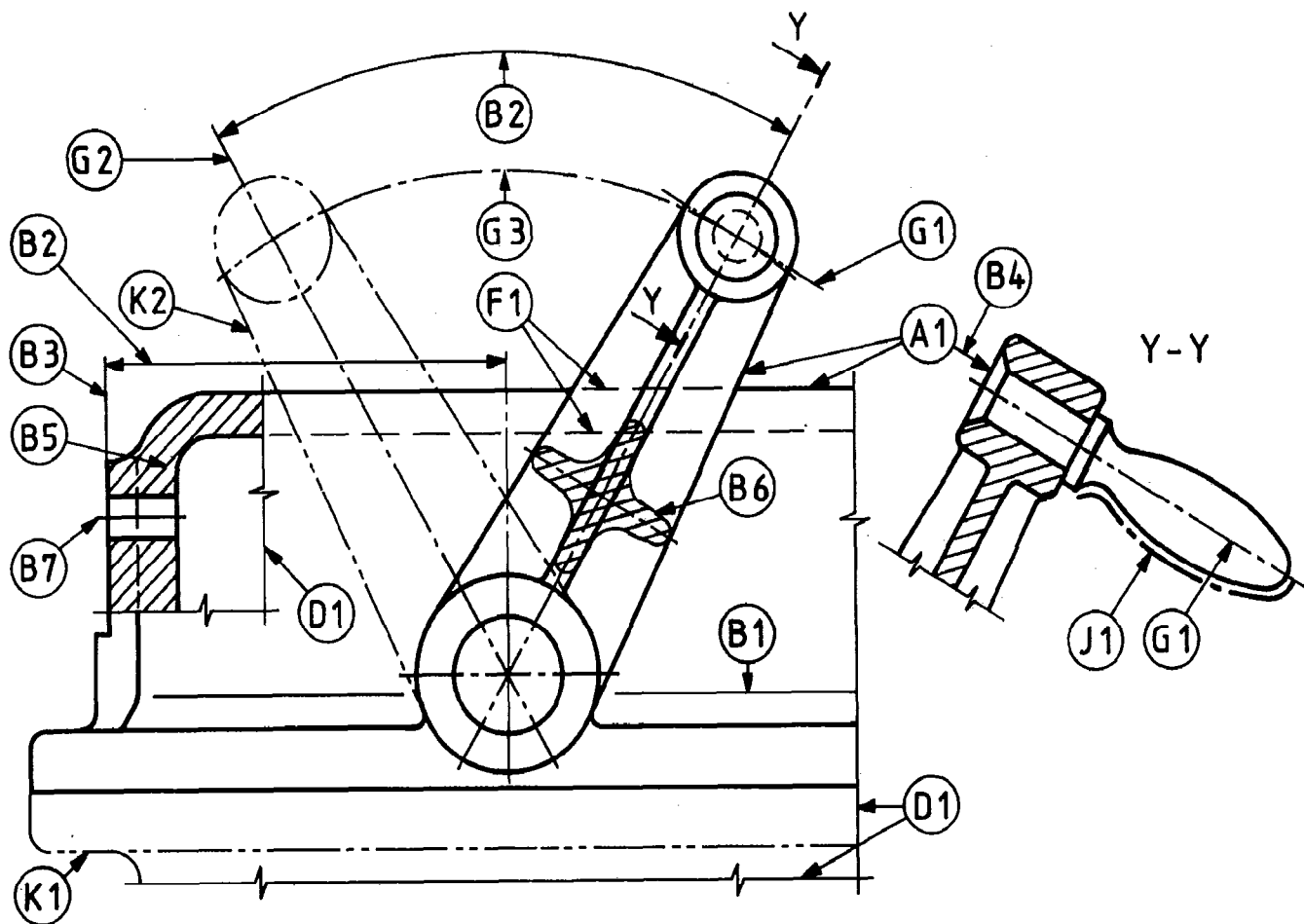

Figure 9

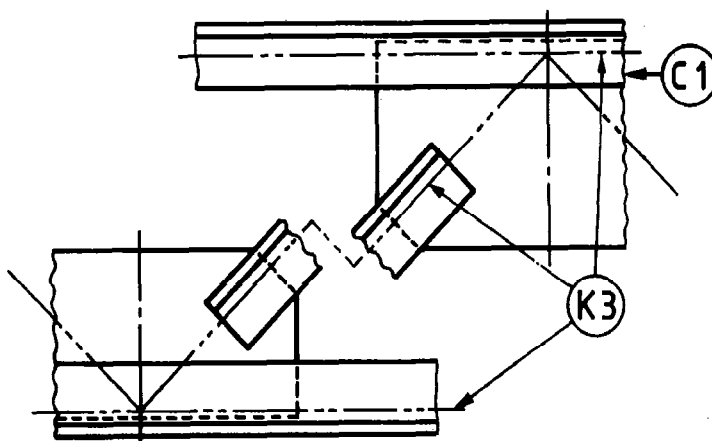

Figure 10

3.2 Thicknesses of lines

Two thicknesses of line are used. The ratio of the thick to the thin line shall not be less than 2:1.

The thickness of lines should be chosen according to the size and the type of the drawing from the following range :

0,18, 0,25, 0,35, 0,5, 0,7, 1, 1,4 and 2 mm¹⁾

For all views of one piece to the same scale, the thickness of the lines should be the same.

3.3 Spacing of lines

The minimum space between parallel lines, including hatching, should never be less than twice the thickness of the heaviest line. It is recommended that these spaces should never be less than 0,7 mm.

3.4 Order of priority of coinciding lines

When two or more lines of different type coincide, the following order of priority should be observed (see figure 11).

- 1) visible outlines and edges (continuous thick line, type A);
- 2) hidden outlines and edges (dashed line, type E or F);
- 3) cutting planes (chain thin line, thick at ends and changes of cutting planes, type H);
- 4) centre lines and lines of symmetry (chain thin line, type G);
- 5) centroidal lines (chain thin double-dashed line, type K);
- 6) projection lines (continuous thin line, type B).

Adjacent outlines of assembled parts shall coincide, black thin sections excepted (see 4.3 and figure 23).

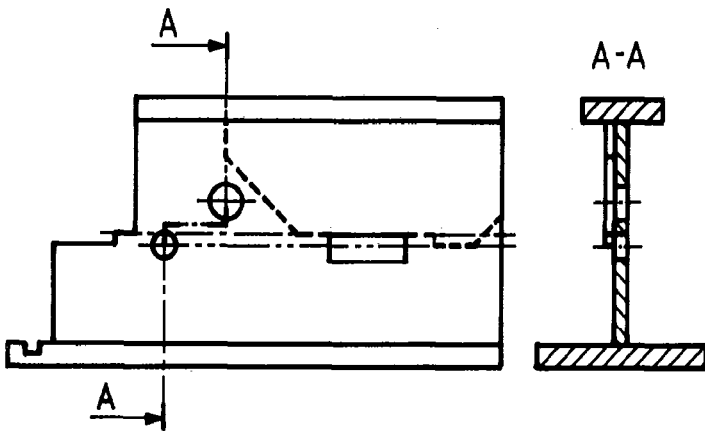

Figure 11

3.5 Termination of leader lines

A leader line is a line referring to a feature (dimension, object, outline, etc.).

Leader lines should terminate :

- with a dot, if they end within outlines of an object (see figure 12);
- with an arrow head, if they end on the outline of an object (see figure 13);
- without dot or arrowhead, if they end on a dimension line (see figure 14).

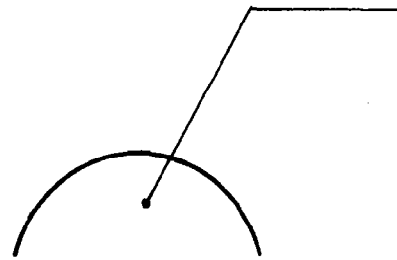

Figure 12

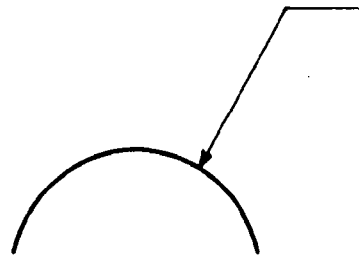

Figure 13

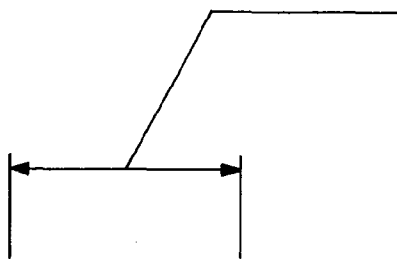

Figure 14

1) Owing to difficulties in certain methods of reproduction, the line thickness of 0,18 mm should be avoided.

4 Sections¹⁾

4.1 Notes on hatching of sections

Hatching is generally used to show areas of sections. Allowance must be made for the methods of reproduction that are to be used.

The simplest form of hatching is usually adequate for the purpose, and may be based upon continuous thin lines (type B) at a convenient angle, preferably 45°, to the principal outlines or lines of symmetry of the sections (see figures 15, 16 and 17).



Figure 15



Figure 16

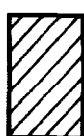

Figure 17

Separate areas of a section of the same component shall be hatched in an identical manner. The hatching of adjacent components shall be carried out with different directions or spacings (see figures 18 and 19).

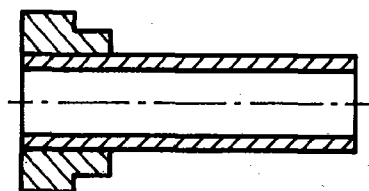

Figure 18

Spacing between the hatching lines should be chosen in proportion to the size of the hatched areas, provided that the requirements for minimum spacing are maintained (see 3.3).

In the case of large areas, the hatching may be limited to a zone following the contour of the hatched area (see figure 19).

Where sections of the same part in parallel planes are shown side by side, the hatching shall be identical, but may be offset along the dividing line between the sections if greater clarity is considered necessary (see figure 20).

Hatching shall be interrupted when it is not possible to place inscriptions outside the hatched area (see figure 21).

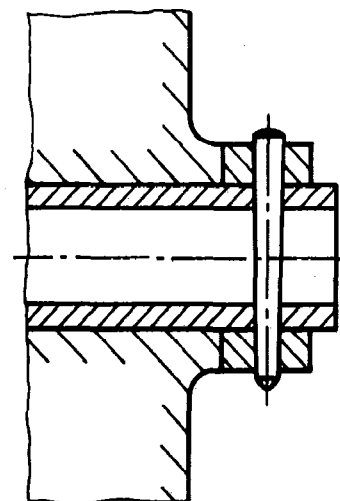

Figure 19

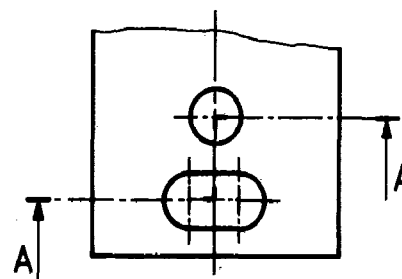
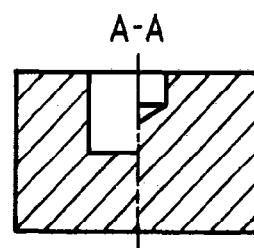

Figure 20

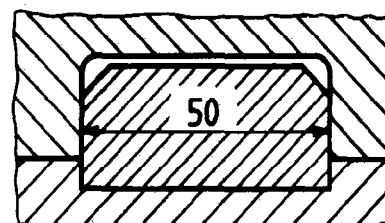

Figure 21

1) In the French language, two terms are employed for section :

“Section” : A section at the cutting plane showing no other outlines.

“Coupe” : A section (or sectional view) at the cutting plane including other visible outlines situated beyond the cutting plane when seen in the direction of viewing.

4.2 Hatching to indicate type of materials

Hatching may be used to indicate type of materials in sections.

If different types of hatching are used to indicate different materials, the meaning of these hatchings shall be clearly defined on the drawing, or by reference to appropriate standards.

4.3 Thin sections

Thin sections may be shown entirely black (see figure 22); a space of not less than 0,7 mm must be left between adjacent sections of this type (see figure 23).



Figure 22



Figure 23

4.4 Notes on sections

The general rules for the arrangement of views (see 2.2) apply equally when drawing sections.

Where the location of a single cutting plane is obvious, no indication of its position or identification is required (see figures 24 and 35).

Where the location is not obvious, or where it is necessary to distinguish between several cutting planes (see figures 25 to 29), the position of the cutting plane(s) shall be indicated by means of a thin chain line, thick at ends and changes of direction (type H). The cutting plane should be identified by designations, for example capital letters, and the direction of viewing should be indicated by arrows. The section should be indicated by the relevant designations (see figures 25 to 29).

The designations on the referenced sections shall be placed either immediately below or above the relevant sections, but in any one drawing the references shall be placed in the same way. No other indication is necessary.

In certain cases, the parts located beyond the cutting plane need not be drawn completely.

In principle, ribs, fasteners, shafts, spokes of wheels, and the like are not cut in longitudinal sections, and therefore should not be hatched (see figures 28 and 29).

4.5 Cutting planes (examples)

Section in one plane (see figures 24 and 25)

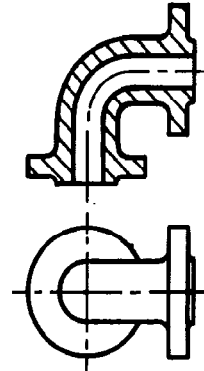

Figure 24

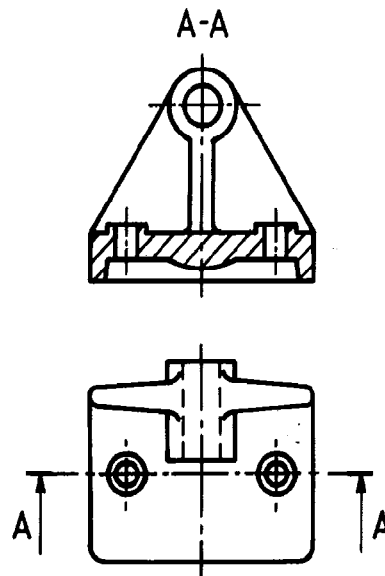

Figure 25

Section in two parallel planes (see figure 26)

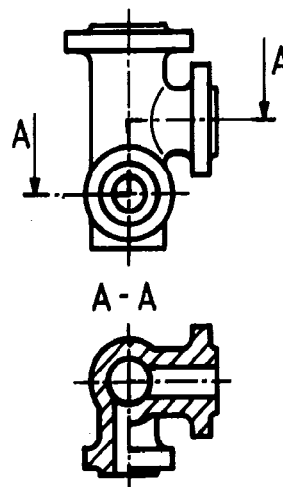

Figure 26

Section in three contiguous planes (see figure 27)

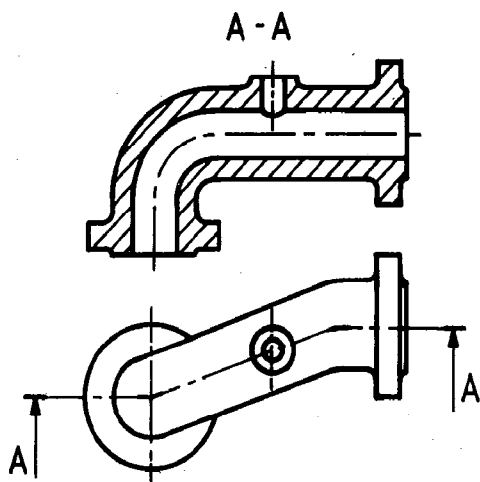

Figure 27

Section in two intersecting planes, one shown revolved into the plane of projection (see figure 28)

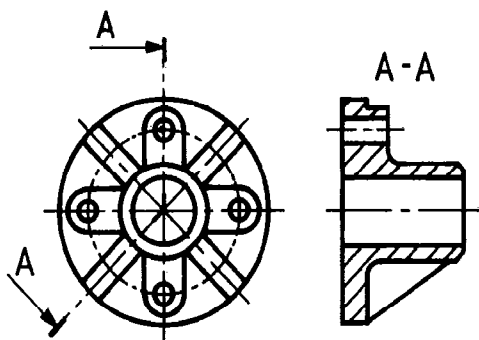

Figure 28

In the case of parts of revolution containing regularly spaced details that require to be shown in section, but are not situated in the cutting plane, provided that no ambiguity can arise, such details may be depicted by rotating them into the cutting plane (see figure 29); but some indication of having done so is recommended.

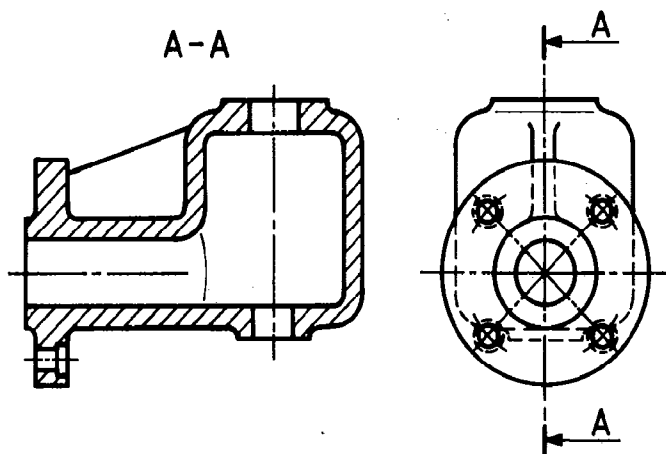

Figure 29

4.6 Sections revolved in the relevant view or removed sections

Cross-sections may be revolved in the relevant view or removed.

4.6.1 When revolved in the relevant view, the outline of the section shall be drawn with continuous thin lines (type B) and further identification is not necessary (see figure 30).

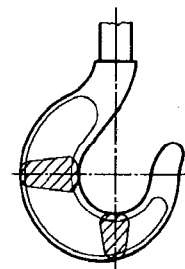

Figure 30

4.6.2 When removed, the outline of the section shall be drawn with continuous thick lines (type A). The removed section may be placed

- either near to and connected with the view by a chain thin line (type G) [see figure 31a);
- or in a different position and identified in the conventional manner as in 4.4 by designations [see figure 31b)].

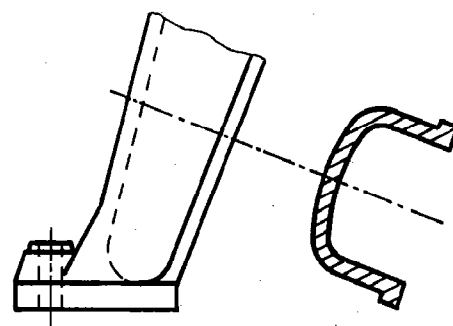

Figure 31a)

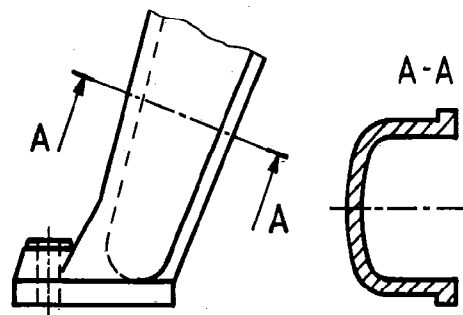

Figure 31b)

4.7 Half sections

Symmetrical parts may be drawn half in full view and half in section (see figure 32).

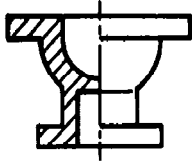

Figure 32

tinuous thin freehand line (type C) (see figure 33) or by continuous thin straight line with zigzags (type D) (see figure 9).

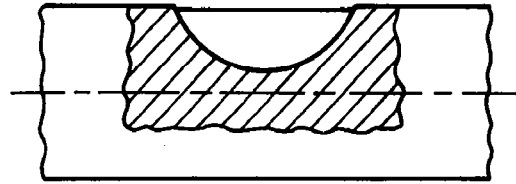

Figure 33

4.8 Local sections

A local section may be drawn if a complete or a half section is not convenient. The local break can be shown by either a con-

4.9 Arrangement of successive sections

Successive sections may be arranged in a manner similar to the examples shown in figures 34, 35 and 36 as convenient for the layout and understanding of the drawing.

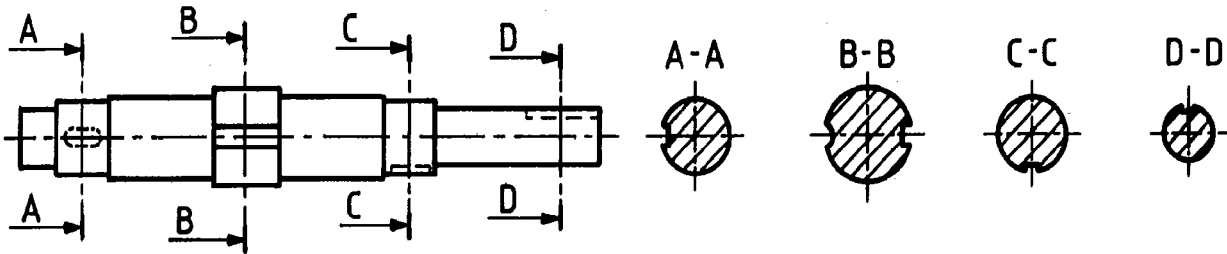

Figure 34

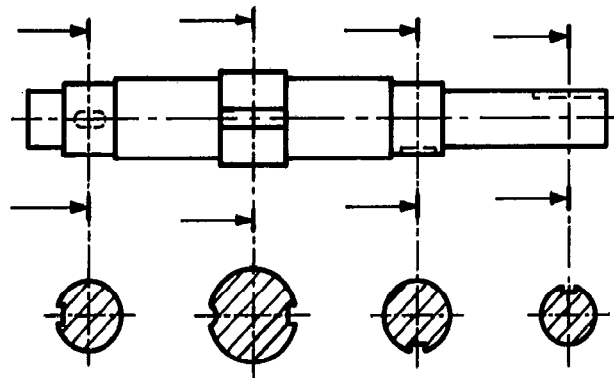

Figure 35

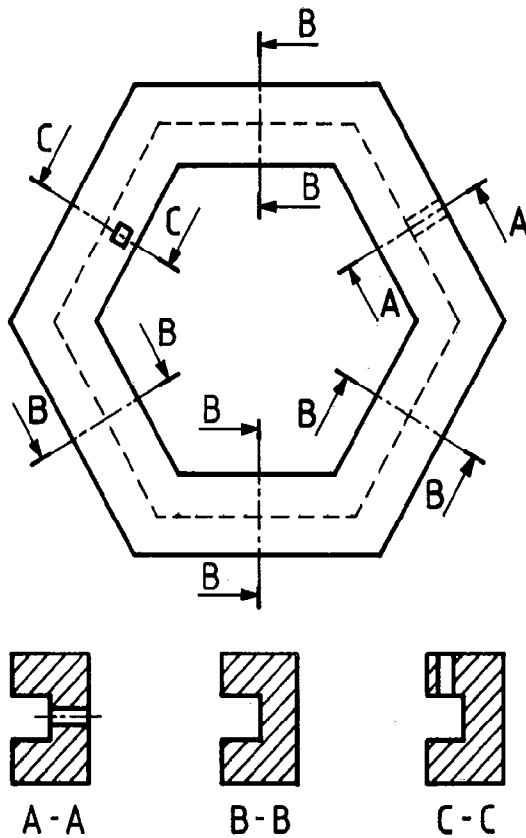

Figure 36

5 Other conventions

5.1 Adjacent parts

Where their representation is necessary, parts adjacent to an object shall be drawn with chain thin double-dashed lines (type K). The adjacent part shall not hide the principal part, but may be hidden by the latter (see figure 37).

Adjacent parts in sections shall not be hatched.

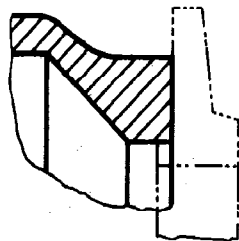

Figure 37

5.2 Intersections

5.2.1 True intersections

True geometric intersection lines shall be drawn with continuous thick lines (type A), when visible, or with dashed lines (type E or F) when hidden (see figure 38).

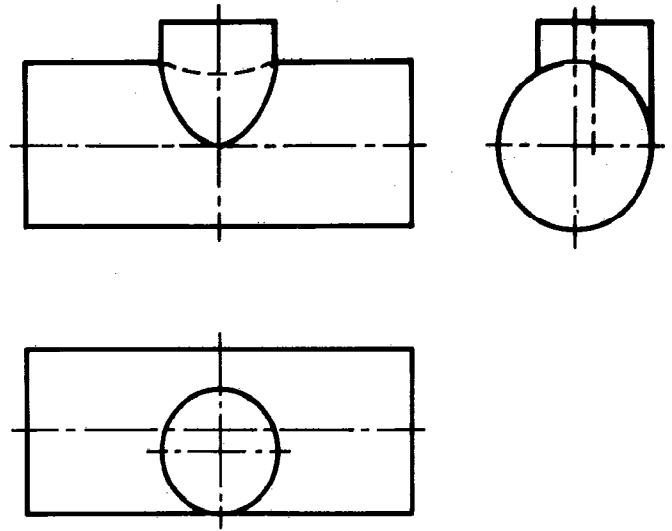

Figure 38

5.2.2 Imaginary intersections

Imaginary intersection lines (such as fillets or rounded corners) may be indicated in a view by means of continuous thin lines (type B), not touching the outlines (see figure 39).

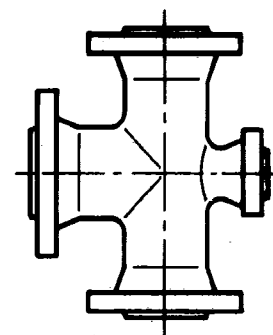

Figure 39

5.2.3 Simplified representation of intersections

Simplified representations of true geometric or imaginary intersection lines may be applied at intersections :

between two cylinders : the curved lines of intersection are replaced by straight lines (see figures 40, 41 and 43);

— between a cylinder and a rectangular prism : the displacement of the straight line of intersection is omitted (see figures 42 and 44).

As the difference in size between the intersecting parts increases, the simplified representation (see figures 40 to 44) only gives a better approach to a real intersection, provided that the axes of the intersecting parts are both mutually perpendicular and intersect, or nearly so.

NOTE - This simplified representation should be avoided if it affects the comprehensibility of the drawing.

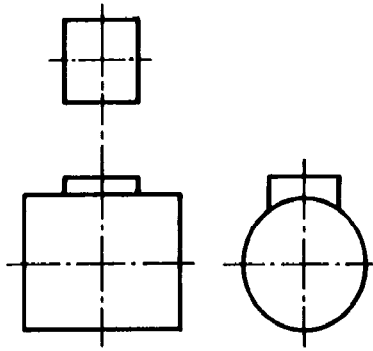

Figure 42

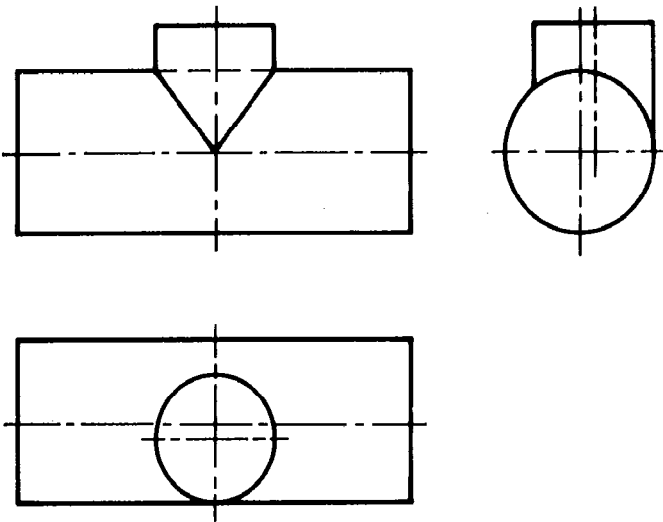

Figure 40

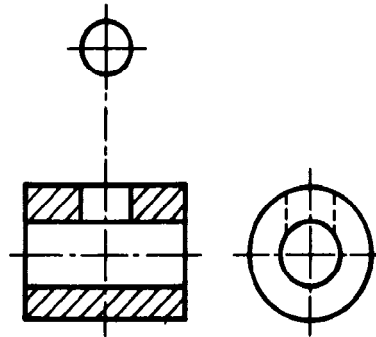

Figure 43

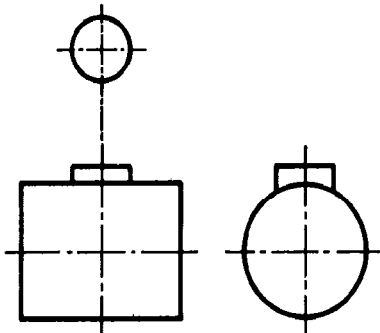

Figure 41

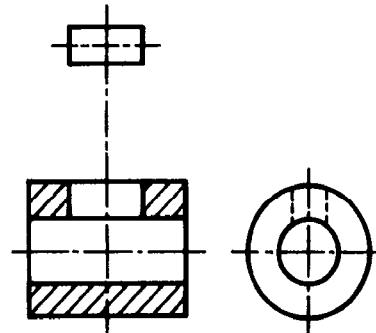

Figure 44

5.3 Conventional representation of square ends and openings

5.3.1 Square ends on shafts

In order to avoid drawing a supplementary view or section, square ends (see figure 45) or tapered square ends on shafts (see figure 46) may be indicated by diagonals drawn as continuous thin lines (type B).

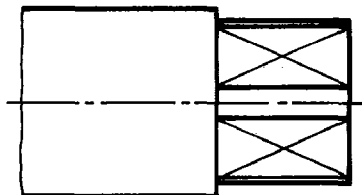

Figure 45

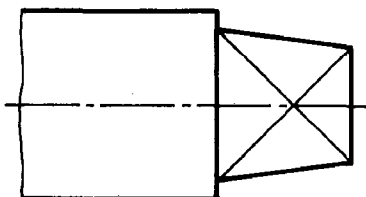

Figure 46

5.3.2 Square and rectangular openings

In order to indicate an opening in a flat part in frontal view, without aid of additional sections, this opening may be shown by drawing its diagonals in continuous thin lines (type B) (see figure 47).

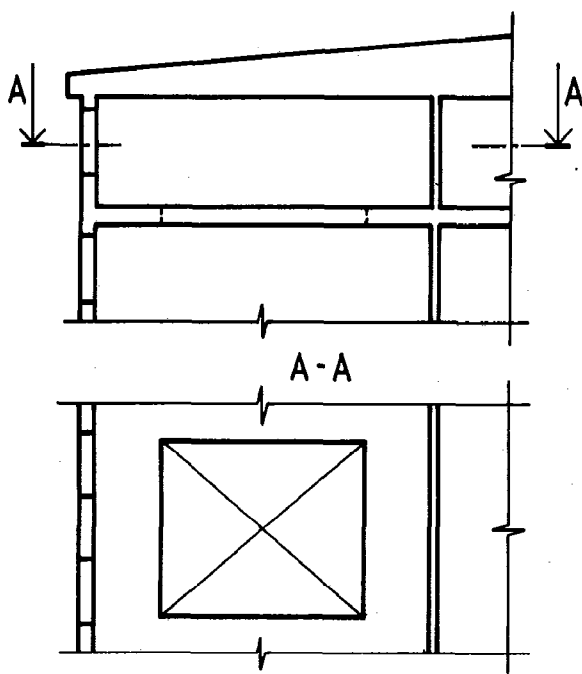

Figure 47

5.4 Parts located in front of a cutting plane

If, it is necessary to indicate parts located in front of the cutting plane, these parts are to be represented by chain thin double-dashed lines (type K) (see figure 48).

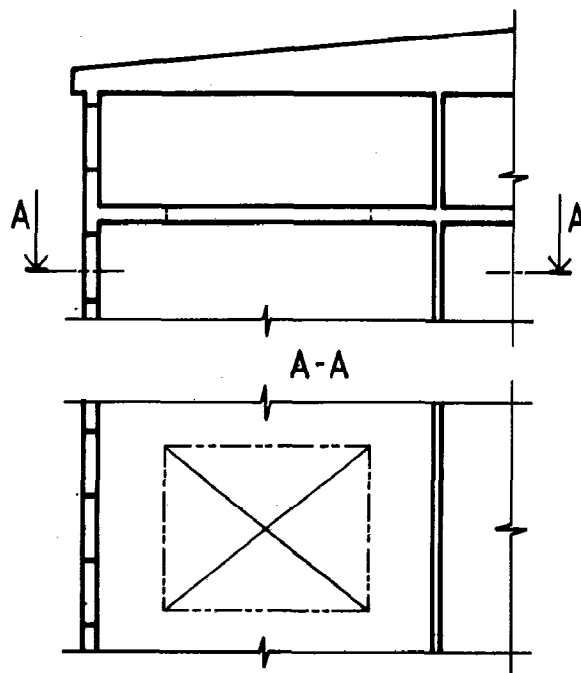

Figure 48

5.5 Views of symmetrical parts

To save time and space, symmetrical objects may be drawn as a fraction of the whole (see figures 49 to 52).

The line of symmetry is identified at its ends by two thin short parallel lines drawn at right angles to it (see figures 49, 50 and 52).

Another method is to show the lines representing the object extending a little beyond the line of symmetry (see figure 51). In this case, the short parallel lines may be omitted.

NOTE — In the application of this practice, it is essential that due care is taken to avoid loss of understanding of the drawing.

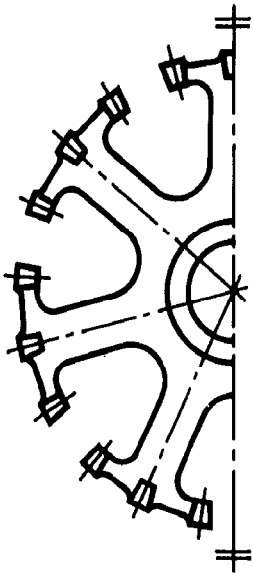

Figure 49

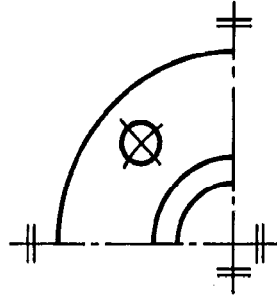

Figure 50

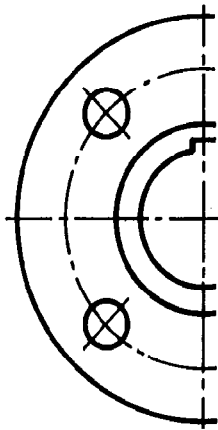

Figure 51

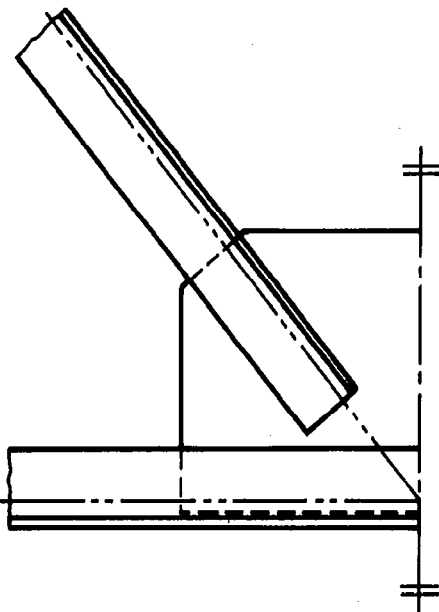

Figure 52

5.6 Interrupted views

In order to save space, it is permissible to show only those portions of a long object which are sufficient for its definition. The limits of the parts retained are shown as for partial views (see 2.6), and the portions are drawn close to each other (see figures 53 and 54).

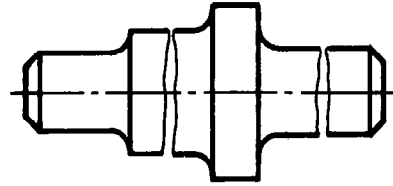

Figure 53

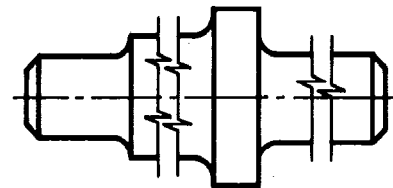

Figure 54

5.7 Simplified representation of repetitive features

The presentation of repetitive features may be simplified as shown in figures 55 and 56.

NOTE — In all cases, the number and kind of repetitive features should be defined by dimensioning or by a note.

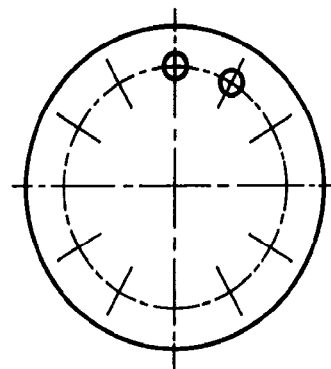

Figure 55

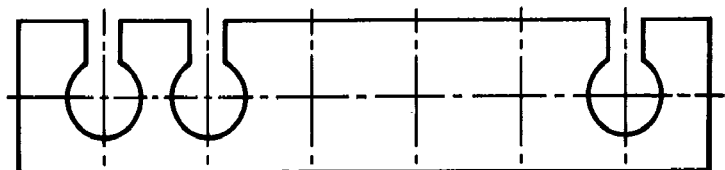

Figure 56

5.8 Elements on a larger scale

In cases where the scale is so small that details of the feature cannot be shown or dimensioned, the feature of the part may be framed by a continuous thin line (type B) and identified by a capital letter [see figure 57a)].

The relevant feature is then drawn to a stated larger scale accompanied by its identification letter [see figure 57b)].

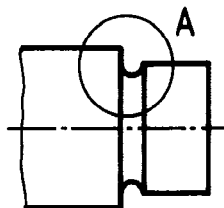

Figure 57a)

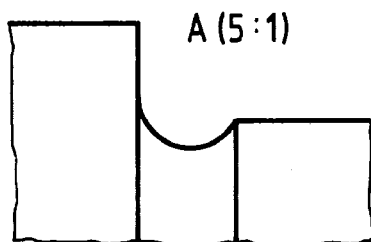

Figure 57b)

5.9 Initial outlines

When it is necessary to depict the initial outlines of a part prior to forming, the initial outline shall be indicated by chain thin double-dashed lines (type K) (see figure 58).

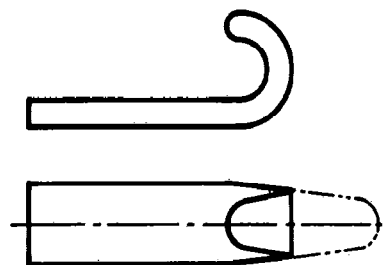

Figure 58

5.10 Use of colours

The use of colours on technical drawings is not recommended. If it is essential for clarity to use colours, then their meanings shall be clearly shown on the drawing or in other relevant documents.

5.11 Transparent objects

All objects made of transparent material should be drawn as non-transparent.