International Standard



109

INTERNATIONAL ORGANIZATION FOR STANDARDIZATION • МЕЖДУНАРОДНАЯ ОРГАНИЗАЦИЯ ПО СТАНДАРТИЗАЦИИ • ORGANISATION INTERNATIONALE DE NORMALISATION

Textile machinery — Working widths of weaving machines

Matériel pour l'industrie textile — Largeurs de tissage des machines à tisser

First edition — 1982-09-15

UDC 677.054.4

Ref. No. ISO 109-1982 (E)

Descriptors : textile machinery, weaving machines, dimensions, width, designation, symbols.

Foreword

ISO (the International Organization for Standardization) is a worldwide federation of national standards institutes (ISO member bodies). The work of developing International Standards is carried out through ISO technical committees. Every member body interested in a subject for which a technical committee has been set up has the right to be represented on that committee. International organizations, governmental and non-governmental, in liaison with ISO, also take part in the work.

Draft International Standards adopted by the technical committees are circulated to the member bodies for approval before their acceptance as International Standards by the ISO Council.

International Standard ISO 109 was developed by Technical Committee ISO/TC 72, *Textile machinery and allied machinery and accessories*, and was circulated to the member bodies in June 1981.

It has been approved by the member bodies of the following countries :

Australia	Japan	South Africa, Rep. of
Czechoslovakia	Korea, Rep. of	Switzerland
France	Mexico	Turkey
Germany, F. R.	Poland	USSR
India	Romania	Yugoslavia

The member bodies of the following countries expressed disapproval of the document on technical grounds :

Belgium
United Kingdom

This International Standard cancels and replaces ISO Recommendation R 109-1968, of which it constitutes a technical revision.

Textile machinery — Working widths of weaving machines

1 Scope and field of application

This International Standard defines the working width as well as other terms which relate to the main dimensions of the working widths of weaving machines.

This International Standard is applicable to weaving machines with or without shuttles, such as to weaving machines with projectiles or rapiers.

2 Definitions and dimensions

2.1 Definitions

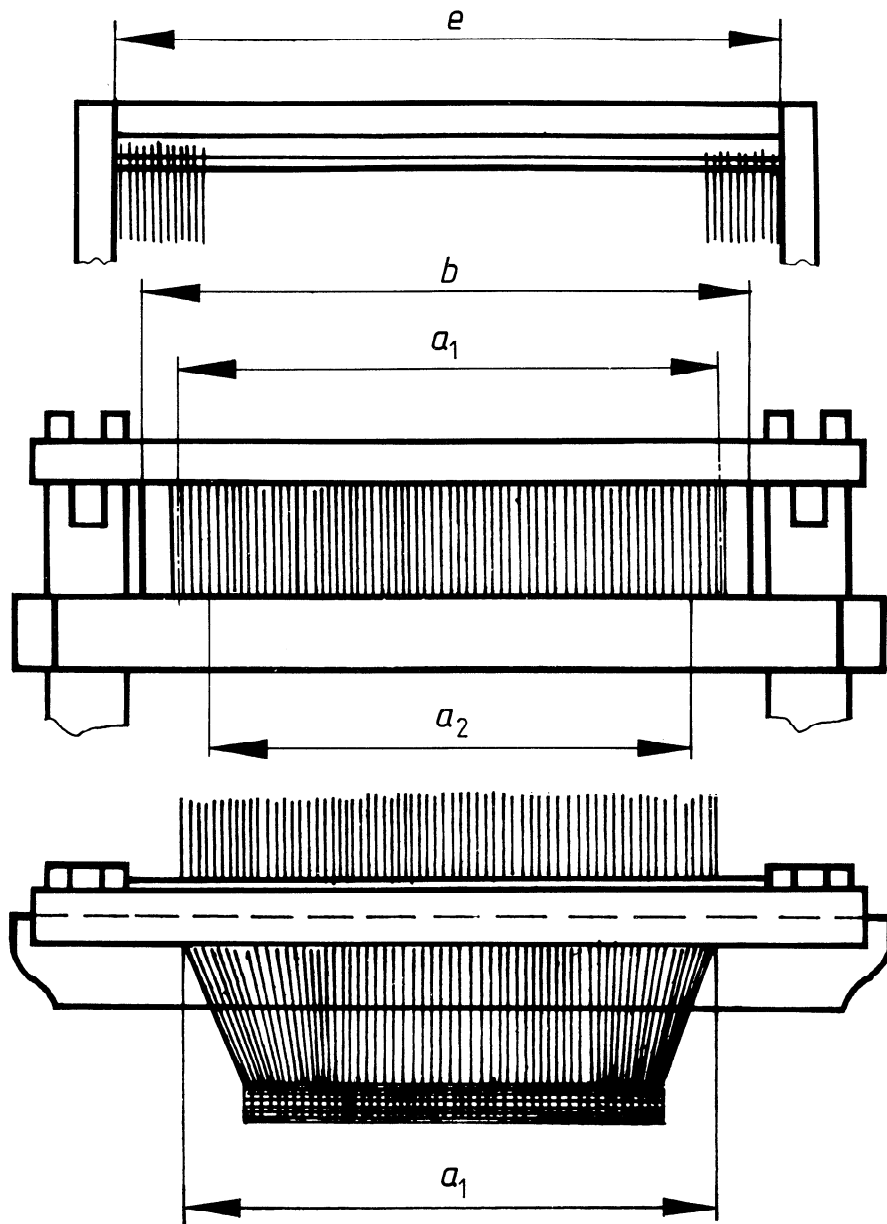

Symbol	Designation	Definition
a_1	Maximum working width	Maximum weavable width of the warp sheet in the reed including the auxiliary selvages when required.
a_2	Minimum working width	Minimum weavable width of the warp sheet in the reed including the auxiliary selvages when required.
b	Reed space	Maximum space available for the insertion of the reed.
e	Usable width of heald frame	Usable width of the heald carrying rod being at disposal for stringing the healds.

2.2 Dimensions

The maximum working widths will be in intervals of 100 mm beginning with the maximum working width of 800 mm.

It is recommended that future steps be in 200 mm intervals.

The dimensions of various weaving machine components, such as the weaver's beam, the warp stop motion, the heald frames, the cloth roller, etc., should be determined, in each individual case, so as to agree with the desired maximum working width.