

# INTERNATIONAL STANDARD

# ISO 105-Z06

First edition  
1998-06-01

---

---

## **Textiles — Tests for colour fastness — Part Z06: Evaluation of dye and pigment migration**

*Textiles — Essais de solidité des teintures —*

*Partie Z06: Évaluation de la migration des teintures et pigments*

This material is reproduced from ISO documents under International Organization for Standardization (ISO) Copyright License number IHS/ICC/1996. Not for resale. No part of these ISO documents may be reproduced in any form, electronic retrieval system or otherwise, except as allowed in the copyright law of the country of use, or with the prior written consent of ISO (Case postale 56, 1211 Geneva 20, Switzerland, Fax +41 22 734 10 79), IHS or the ISO Licensor's members.



Reference number  
ISO 105-Z06:1998(E)

**ISO 105-Z06:1998(E)****Foreword**

ISO (the International Organization for Standardization) is a worldwide federation of national standards bodies (ISO member bodies). The work of preparing International Standards is normally carried out through ISO technical committees. Each member body interested in a subject for which a technical committee has been established has the right to be represented on that committee. International organizations, governmental and non-governmental, in liaison with ISO, also take part in the work. ISO collaborates closely with the International Electrotechnical Commission (IEC) on all matters of electrotechnical standardization.

Draft International Standards adopted by the technical committees are circulated to the member bodies for voting. Publication as an International Standard requires approval by at least 75 % of the member bodies casting a vote.

International Standard ISO 105-Z06 was prepared by Technical Committee ISO/TC 38, *Textiles*, Subcommittee SC 1, *Tests for coloured textiles and colorants*.

ISO 105 was previously published in thirteen "parts", each designated by a letter (e.g. "Part A»), with publication dates between 1978 and 1985. Each part contained a series of "sections", each designated by the respective part letter and by a two-digit serial number (e.g. "Section A01"). These sections are now being republished as separate documents, themselves designated "parts" but retaining their earlier alphanumeric designations. A complete list of these parts is given in ISO 105-A01.

Annex A of this part of ISO 105 is for information only.

© ISO 1998

All rights reserved. Unless otherwise specified, no part of this publication may be reproduced or utilized in any form or by any means, electronic or mechanical, including photocopying and microfilm, without permission in writing from the publisher.

International Organization for Standardization  
Case postale 56 • CH-1211 Genève 20 • Switzerland  
Internet central@iso.ch  
X.400 c=ch; a=400net; p=iso; o=isocs; s=central

Printed in Switzerland

# Textiles — Tests for colour fastness —

## Part Z06: Evaluation of dye and pigment migration

### 1 Scope

This part of ISO 105 describes a method for assessing the migration propensity of a pad liquor system containing dyes or pigments, subsequently referred to as colorants, and which may also contain different types and amounts of migration inhibitors. The degree of migration is obtained by visual examination or by reflectance measurements.

The test method may be used to compare the migration propensity of dyes and the effect on migration of different types of migration inhibitors, thickeners and electrolyte. The method may also be used to evaluate a pad liquor with which migration has been found on a continuous dye range.

### 2 Normative reference

The following standard contains provisions which, through reference in this text, constitutes provisions of this part of ISO 105. At the time of publication, the edition indicated was valid. All standards are subject to revision and parties to agreements based on this part of ISO 105 are encouraged to investigate the possibility of applying the most recent edition of the standard listed below. Members of IEC and ISO maintain registers of currently valid International Standards.

ISO 105-A02: 1993, *Textiles - Tests for colour fastness - Part A02 Grey scale for assessing change in colour.*

### 3 Definitions

For the purposes of this part of ISO 105, the following definitions apply.

**3.1 dye:** Colorant applied to or formed on a substrate, via the molecularly dispersed state, which exhibits some degree of permanence.

**3.2 migration:** Movement of a chemical, dye or pigment between fibres, within a substrate or between substrates due to capillary forces.

NOTE — Migration may occur in textile processing, testing, storage and use.

**3.3 pigment:** Colorant in particulate form which is insoluble in a substrate, but which can be dispersed in the substrate to modify its colour.

**3.4 pad:** Impregnation of a substrate (usually fabric) with a liquor, followed by squeezing between rollers.

**ISO 105-Z06:1998(E)****4 Principle**

Fabric impregnated with test colorant alone, or with test colorant and migration inhibitor, is dried while partially covered with a watch glass, permitting differential drying and therefore, migration to occur. The degree of migration is evaluated by visual examination or by reflectance measurements of the covered and uncovered areas.

**NOTES**

- 1 When drying conditions are not constant and/or uniform, uneven migration may occur, causing shade variations during a run, or shade differences between the face and back, or between the side and centre of the fabric.
- 2 The pad liquor composition may be modified by varying the amount or type of migration inhibitor and tested in the laboratory prior to the application on the range. The colorant concentration, the fabric and the wet pickup should be the same in the laboratory as used on the range. It is then possible to correlate the test results with the improvement experienced in practice.

Two procedures are described:

**Procedure A.** The fabric assembly is allowed to dry at room temperature. The procedure is very simple, but time-consuming (overnight).

**Procedure B.** The fabric assembly is dried in a laboratory dryer or oven, either with, or without air circulation. This procedure is faster but somewhat more complicated than procedure A.

**5 Apparatus and materials****5.1 Fabric pieces for dyeing.**

NOTE — For disperse dyes, vat dyes and pigments, generally the preferred fabric is a blend of 65 %:35 % (*m/m*) polyester: cotton gabardine or heavy twill, heat set, bleached and mercerized. For soluble dyes with affinity to cellulose (e.g. reactive dyes), the preferred fabric is a bleached and mercerized 100 % cotton gabardine or heavy twill. However, any other fabric intended for use on a continuous dye range may be chosen.

**5.2 Balance,** capable of weighing to an accuracy of 1 mg.

**5.3 Laboratory padder.**

**5.4 Glass plate,** 350 mm x 600 mm, for procedure A.

**5.5 Watch glasses,** 90 mm diameter with 22 mm arch punch.

**5.6 Laboratory pin frame,** for procedure B.

**5.7 Aluminium rings,** 110 mm outer diameter, 80 mm inner diameter, 1 mm thickness, for procedure B.

**5.8 Clips,** e.g. metal binder clips for procedure B.

**5.9 Laboratory dryer or oven,** for procedure B.

**5.10 Grey scale for assessing change in colour,** in accordance with ISO 105-A02.

**5.11 Spectrophotometer,** for reflectance measurements.

**6 Test specimen**

Colorant(s), migration inhibitor, thickening agent and other auxiliaries (e.g. electrolyte for reactive dyes) in desired concentration(s) to be tested as appropriate.

**7 Procedure**

**WARNING** — It is the user’s responsibility to use safe and proper techniques in handling materials in this test method and to follow good laboratory practices. Consult manufacturers for specific details, such as material safety data sheets and other manufacturers’ recommendations. Users should also comply with any national and local safety regulations.

**7.1 Procedure A**

Cut a 150 mm × 300 mm piece of fabric (5.1), weigh it using the balance (5.2) and then pad it using the laboratory padder (5.3) at (20 ± 2) °C. If other padding temperatures are used, these shall be stated in the test report. Generally the wet pickup is 60 % by mass, but may be adjusted to simulate wet pickup of a particular fabric to be run on a particular range. The pad bath contains colorants and usually, auxiliaries.

**NOTE** — Observe padder safety. Normal safeguards on padders should not be removed. Ensure that there is an adequate guard at the roller nip point. A foot-operated kick-off is recommended.

Obtain the desired wet pickup by adjusting the pressure at the nip of the pad rolls. Calculate the percent wet pickup as the mass gained by the substrate after padding using the following equation:

$$WP = 100 \times \left( \frac{m_1}{m_0} - 1 \right)$$

where

- WP is the percent mass wet pickup;
- $m_1$  is the mass of the fabric after padding;
- $m_0$  is the mass of the fabric before padding.

Immediately after padding place the fabric on a flat glass plate (5.4). Place the watch glass (5.5) on the fabric as shown in figure 1, and leave the fabric to dry at room temperature. Remove the watch glass and determine the degree of migration in accordance with clause 8 by comparing the dye concentration in the area of the fabric which was covered by the watch glass to the dye concentration in the area of the fabric which was not covered.

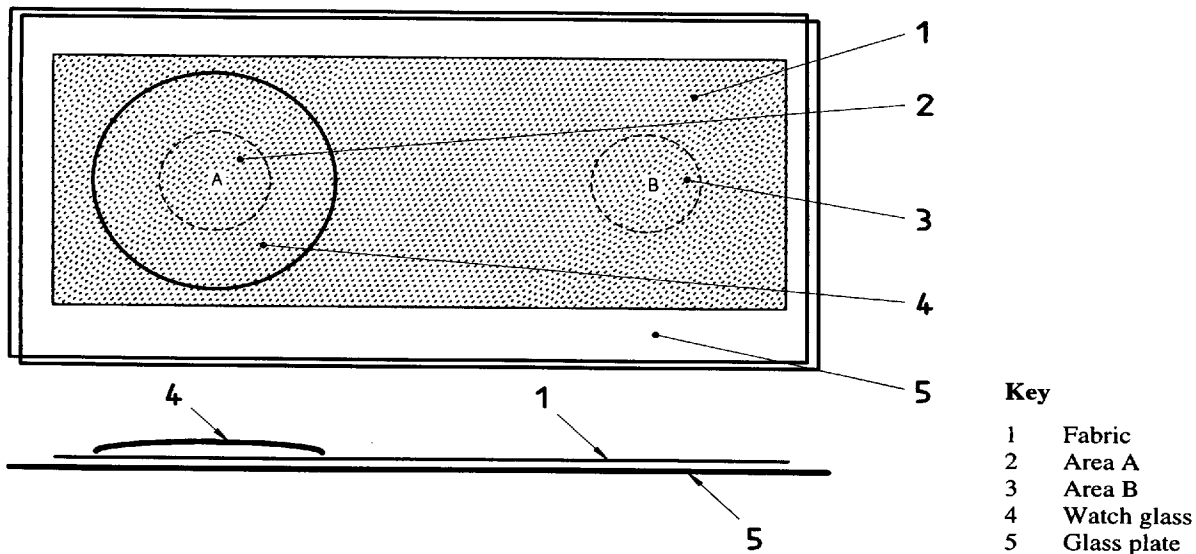

**Figure 1 — Layout of apparatus for inducing colorant migration using procedure A**

**7.2 Procedure B**

Proceed as described in procedure A, using a piece of fabric sufficiently large (usually about 110 mm x 220 mm) to fit a laboratory pin frame (5.6).

Immediately after padding mount the fabric taut on the pin frame (5.6), sandwiched between two watch glasses (5.5), one on the fabric face and one directly underneath on the back of the fabric. Hold the watch glasses in place with two aluminium rings (5.7) and clips (5.8) as shown in figure 2. Dry the fabric assembly horizontally at  $(100 \pm 2) \text{ }^\circ\text{C}$  for approximately 7 min (or until dry) in a laboratory dryer or oven (5.9).

Remove the watch glasses and remove the fabric from the pin frame. Determine the degree of migration in accordance with clause 8 by comparing the dye concentration in the area of the fabric which was covered by the watch glasses, to the dye concentration in the area of the fabric which was not covered.

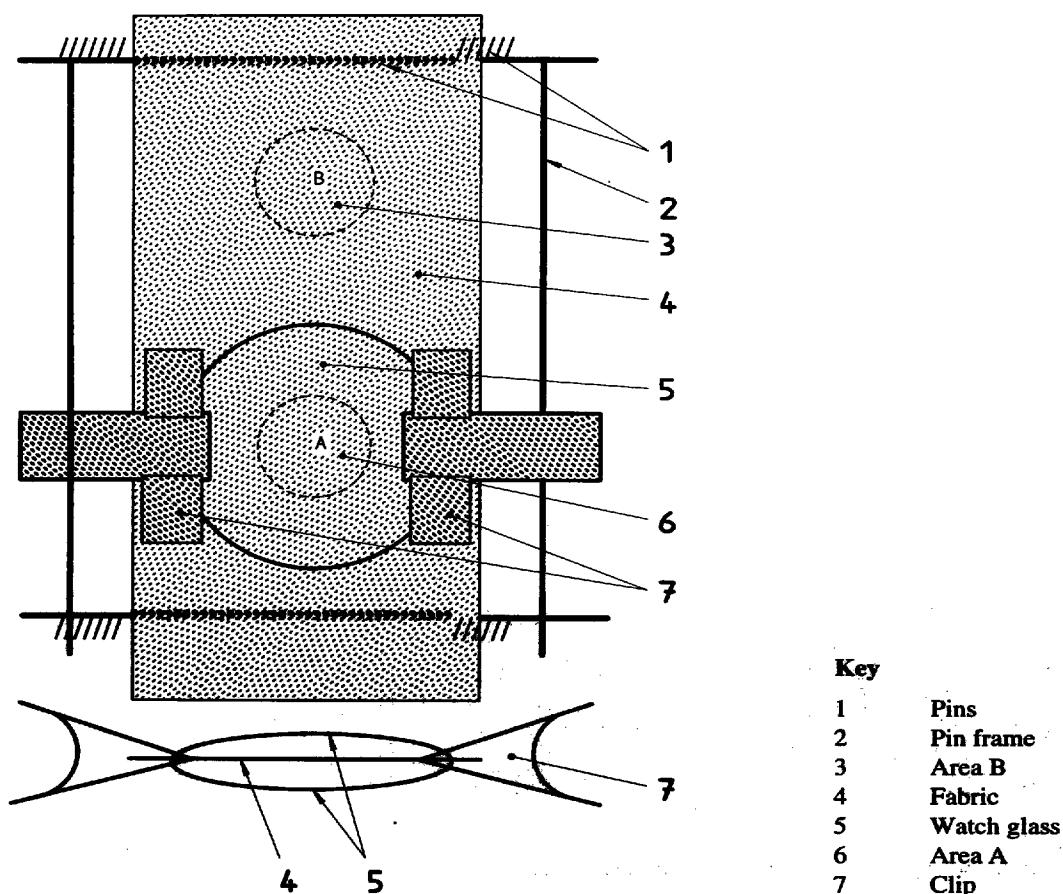

**Figure 2 — Layout of apparatus for inducing colorant migration using procedure B**

## 8 Evaluation

### 8.1 Visual evaluation

Compare the depth of colour on the area of the fabric which was covered by the watch glass(es) (area A in figures 1 and 2) to the depth of colour on the area of the fabric which was not covered (area B in figures 1 and 2), using the grey scale for assessing change in colour (5.10).

Assess the migration of the colorant(s) on the following scale:

- Grade 5 — no migration
- Grade 4 — slight migration
- Grade 3 — medium migration
- Grade 2 — severe migration
- Grade 1 — very severe migration

### 8.2 Reflectance evaluation

**8.2.1** Using a spectrophotometer (5.11) determine the wavelength of maximum absorption on the area of the fabric which was not covered with the watch glass(es) (area B in figures 1 and 2). This is the reference area.

**8.2.2** Measure the reflectance at the wavelength of maximum absorption as determined in 8.2.1 on the area of the fabric which was covered by the watch glass(es) (area A in figures 1 and 2) and on the area of the fabric which was not covered (area B in figures 1 and 2). Convert these values to  $K/S$  using the following equation:

$$K/S = (1 - R)^2/2R$$

where

- $K/S$  is the ratio of light absorption to light scattering (Kubelka Munk function);
- $R$  is the reflectance factor at the wavelength of maximum absorption of the reference area (8.2.1).

Calculate the colorant migration as a percentage to the nearest 1% from the following equation:

$$M = 100[1 - (K/S)_a/(K/S)_b]$$

where

- $M$  is the percent migration;
- $(K/S)_a$  is the  $K/S$  value calculated from the reflectance of area A;
- $(K/S)_b$  is the  $K/S$  value calculated from the reflectance of area B.

NOTE — More accurate results may be obtained when, prior to the evaluation or measurement, the dye on the fabric is fixed by appropriate conventional methods, e.g. thermofix for disperse dyes, pad steam for vat and reactive dyes. (Resin-curing of pigments does not normally change the shade.)

## 9 Test report

The test report shall include the following information:

- a) Reference to this part of ISO 105, i.e. ISO 105-Z06:1998;
- b) The pad liquor composition, including concentration of colorant(s) and, when used, migration inhibitor, thickener and electrolyte;
- c) The substrate used and the wet pickup;

- d) For procedure A: room temperature and relative humidity during drying;
- e) For procedure B: whether dried with or without air circulation;
- f) For visual examination: the grey scale grade;
- g) For reflectance measurements: the percentage colorant migration calculated from 8.2;
- h) Details of any deviations from the test procedure.

NOTE — Precision for this test method has not been established. Users should use standard statistical techniques in making any comparison of test results for either within-laboratory or between-laboratory averages.



**Annex A**  
**(informative)**

**Bibliography**

- [1] GERBER, H., *Melliand Textil Berichte*, Vol. 53, No.3, p335, 1972.
- [2] ETTERS, J.N., *Textile Chemist and Colorist*, Vol. 4, No.6, p160, 1972.
- [3] LEHMANN, H. and SOMM, F., *Textile Praxis International*, Vol. 28, No.1, p52, 1973.
- [4] ETTERS, J.N., *Modern Knitting Management*, Vol. 51, No.2, p24, 1973.
- [5] URBANIK, A. and ETTERS, J.N., *Textile Research Journal*, Vol. 43, p657, 1973.
- [6] AATCC Northern Piedmont Section, *Textile Chemist and Colorist*, Vol. 7, No. 11, p192, 1975.

---

---

**ICS 59.080.01**

**Descriptors:** textiles, dyes, colour fastness, tests, colour-fastness tests, determination, migrations, pigments.

Price based on 7 pages

---

---