

INTERNATIONAL
STANDARD

ISO
105-E11

Third edition
1994-09-15

Textiles — Tests for colour fastness —
Part E11:
Colour fastness to steaming

Textiles — Essais de solidité des teintures —

Partie E11: Solidité des teintures au vaporisage à la pression atmosphérique



Reference number
ISO 105-E11:1994(E)

Foreword

ISO (the International Organization for Standardization) is a worldwide federation of national standards bodies (ISO member bodies). The work of preparing International Standards is normally carried out through ISO technical committees. Each member body interested in a subject for which a technical committee has been established has the right to be represented on that committee. International organizations, governmental and non-governmental, in liaison with ISO, also take part in the work. ISO collaborates closely with the International Electrotechnical Commission (IEC) on all matters of electrotechnical standardization.

Draft International Standards adopted by the technical committees are circulated to the member bodies for voting. Publication as an International Standard requires approval by at least 75 % of the member bodies casting a vote.

International Standard ISO 105-E11 was prepared by Technical Committee ISO/TC 38, *Textiles*, Subcommittee SC 1, *Tests for coloured textiles and colorants*.

This third edition cancels and replaces the second edition (ISO 105-E11:1987), of which it constitutes a technical revision.

ISO 105 was previously published in thirteen "parts", each designated by a letter (e.g. "Part A"), with publication dates between 1978 and 1985. Each part contained a series of "sections", each designated by the respective part letter and by a two-digit serial number (e.g. "Section A01"). These sections are now being republished as separate documents, themselves designated "parts" but retaining their earlier alphanumeric designations. A complete list of these parts is given in ISO 105-A01.

© ISO 1994

All rights reserved. Unless otherwise specified, no part of this publication may be reproduced or utilized in any form or by any means, electronic or mechanical, including photocopying and microfilm, without permission in writing from the publisher.

International Organization for Standardization
Case Postale 56 • CH-1211 Genève 20 • Switzerland

Printed in Switzerland

Textiles — Tests for colour fastness —

Part E11: Colour fastness to steaming

1 Scope

This part of ISO 105 specifies a method for determining the resistance of the colour of textiles of all kinds and in all forms to the action of steam under atmospheric pressure.

2 Normative references

The following standards contain provisions which, through reference in this text, constitute provisions of this part of ISO 105. At the time of publication, the editions indicated were valid. All standards are subject to revision, and parties to agreements based on this part of ISO 105 are encouraged to investigate the possibility of applying the most recent editions of the standards indicated below. Members of IEC and ISO maintain registers of currently valid International Standards.

ISO 105-A01:1994, *Textiles — Tests for colour fastness — Part A01: General principles of testing.*

ISO 105-A03:1993, *Textiles — Tests for colour fastness — Part A03: Grey scale for assessing staining.*

ISO 105-F:1985, *Textiles — Tests for colour fastness — Part F: Standard adjacent fabrics.*

3 Principle

A specimen of the textile in contact with specified adjacent fabrics is rolled into a cylinder and placed in the neck of a flask containing boiling water. The staining of the adjacent fabrics is assessed by comparison with the grey scale.

4 Apparatus

4.1 Glass tube, open at both ends, with 30 mm inside diameter, mounted in a cork stopper and fitted into the neck of a wide-neck conical flask of about 2 litres capacity. A wire ring is fixed in the cork stopper, with the loop covered with a thin fabric to catch spray. The flask contains about 0,5 litre of water, to which some small beads are added (see figure 1).

4.2 Adjacent fabric, complying with the relevant sections F01 to F08 of ISO 105-F:1985, measuring 40 mm × 100 mm, of the same fibre as the specimen.¹⁾

4.3 Two cotton adjacent fabrics, complying with section F02 of ISO 105-F:1985, each measuring 40 mm × 100 mm¹⁾.

4.4 Undyed scoured wool felt.

4.5 Grey scale for assessing staining, complying with ISO 105-A03.

1) The length of 100 mm may be reduced if the fabric to be tested is too thick for the cylinder to be inserted into the tube. To facilitate rolling, stitch the composite specimen at one end.

5 Test specimen

5.1 If the textile to be tested is fabric, prepare a composite specimen measuring 40 mm × 100 mm ¹⁾ by placing successively on a piece of cotton adjacent fabric (4.3) the textile to be tested, a piece of adjacent fabric (4.2) and a further piece of cotton adjacent fabric (4.3). Roll this composite specimen into a cylinder, with the fabric being tested as near the middle as possible.

5.2 If the textile to be tested is yarn, knit it into fabric and use a piece 40 mm × 100 mm ¹⁾; treat as in 5.1.

5.3 If the textile to be tested is loose fibre, comb and compress enough of it to form a sheet 40 mm × 100 mm ¹⁾, and place it on a piece of cotton adjacent fabric (4.3); place successively on this a piece of adjacent fabric (4.2) and a further piece of cotton adjacent fabric (4.3). Roll the composite specimen into a cylinder, with the fibre to be tested as near the middle as possible.

6 Procedure

6.1 Bring the water in the conical flask (see 4.1) to the boil. Wrap the cylindrical composite specimen in felt (4.4) so that the whole fits snugly into the glass tube (4.1) in the neck of the flask and is retained by protuberances in the lower part of the tube. Steam for 30 min.

6.2 Remove the composite specimen from the tube, separate the components and dry by hanging in air at a temperature not exceeding 60 °C.

6.3 Assess the staining of the adjacent fabrics by comparison with the grey scale (4.5).

7 Test report

The test report shall include the following information:

- the number and year of publication of this part of ISO 105, i.e. ISO 105-E11:1994;
- all details necessary for the identification of the sample tested;
- the numerical grey scale rating for staining of the adjacent fabrics.

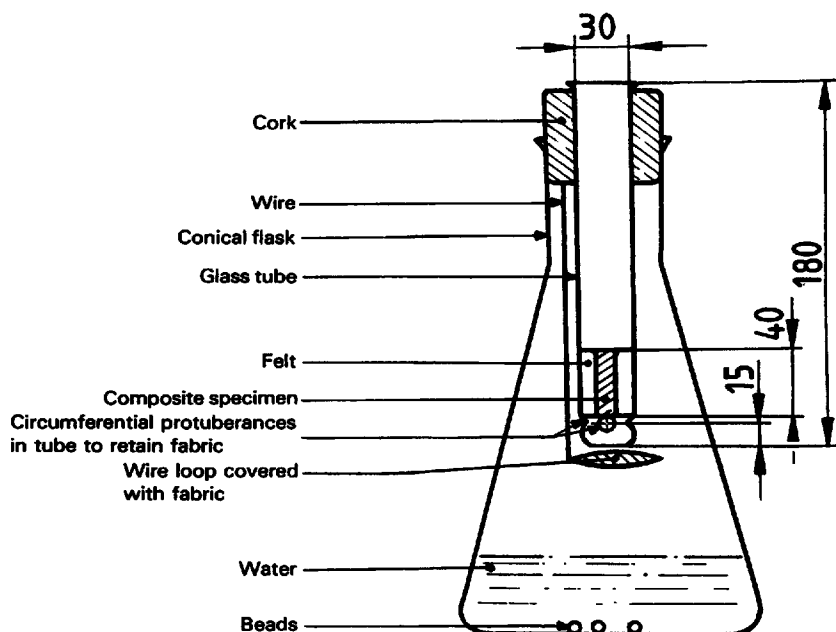

Figure 1 — Apparatus for determining colour fastness to steaming under atmospheric pressure

ICS 59.080.10

Descriptors: textiles, dyes, tests, water resistance tests, water vapor tests, determination, colour fastness, steam.

Price based on 2 pages
