

INTERNATIONAL STANDARD

**ISO
90-3**

Second edition
2000-08-01

Light gauge metal containers — Definitions and determination of dimensions and capacities —

Part 3: Aerosol cans

*Réipients métalliques légers — Définitions et détermination des
dimensions et des capacités*

Partie 3: Boîtiers pour aérosols



Reference number
ISO 90-3:2000(E)

© ISO 2000

PDF disclaimer

This PDF file may contain embedded typefaces. In accordance with Adobe's licensing policy, this file may be printed or viewed but shall not be edited unless the typefaces which are embedded are licensed to and installed on the computer performing the editing. In downloading this file, parties accept therein the responsibility of not infringing Adobe's licensing policy. The ISO Central Secretariat accepts no liability in this area.

Adobe is a trademark of Adobe Systems Incorporated.

Details of the software products used to create this PDF file can be found in the General Info relative to the file; the PDF-creation parameters were optimized for printing. Every care has been taken to ensure that the file is suitable for use by ISO member bodies. In the unlikely event that a problem relating to it is found, please inform the Central Secretariat at the address given below.

© ISO 2000

All rights reserved. Unless otherwise specified, no part of this publication may be reproduced or utilized in any form or by any means, electronic or mechanical, including photocopying and microfilm, without permission in writing from either ISO at the address below or ISO's member body in the country of the requester.

ISO copyright office
Case postale 56 • CH-1211 Geneva 20
Tel. + 41 22 749 01 11
Fax + 41 22 749 09 47
E-mail copyright@iso.ch
Web www.iso.ch

Printed in Switzerland

Contents

Page

Foreword	iv
Introduction	v
1 Scope	1
2 Terms and definitions	1
3 Determination of dimensions	7
4 Determination of capacities	9
5 Tolerances on capacities	10
6 Designation	11
Annexe A (informative) Dimensions of the top end of three-piece necked-in tinfoil cans	12
Bibliography	13

© ISO 2000. All rights reserved.

Foreword

ISO (the International Organization for Standardization) is a worldwide federation of national standards bodies (ISO member bodies). The work of preparing International Standards is normally carried out through ISO technical committees. Each member body interested in a subject for which a technical committee has been established has the right to be represented on that committee. International organizations, governmental and non-governmental, in liaison with ISO, also take part in the work. ISO collaborates closely with the International Electrotechnical Commission (IEC) on all matters of electrotechnical standardization.

International Standards are drafted in accordance with the rules given in the ISO/IEC Directives, Part 3.

Draft International Standards adopted by the technical committees are circulated to the member bodies for voting. Publication as an International Standard requires approval by at least 75 % of the member bodies casting a vote.

Attention is drawn to the possibility that some of the elements of this part of ISO 90 may be the subject of patent rights. ISO shall not be held responsible for identifying any or all such patent rights.

International Standard ISO 90-3 was prepared by Technical Committee ISO/TC 52, *Light gauge metal containers*, Subcommittee SC 6, *Aerosol containers*.

This second edition cancels and replaces the first edition (ISO 90-3:1986) which has been technically revised.

ISO 90 consists of the following parts, under the general title *Light gauge metal containers — Definitions and determination of dimensions and capacities*:

- *Part 1: Open-top cans*
- *Part 2: General use containers*
- *Part 3: Aerosol cans*

NOTE An "open-top can" is a can one end of which is double-seamed after filling. A "general use container" is a container which is sealed after filling with a closure that need not be double-seamed.

Annex A of this International Standard is for information only.

Introduction

ISO 90 consists of three parts which group definitions, methods of determination of dimensions and capacities, as well as tolerances and designations of rigid containers made of metal with a maximum nominal material thickness of 0,49 mm.

Light gauge metal containers — Definitions and determination of dimensions and capacities —

Part 3: Aerosol cans

1 Scope

This part of ISO 90 defines the diameters, apertures, constructions, shapes and capacities of round, aerosol cans. It specifies methods for determining diameters, gross lidded and brimful capacities. It also gives tolerances on capacity and recommends an international designation.

NOTE A list of standards dealing with materials used for aerosol cans is given in the Bibliography.

2 Terms and definitions

For the purposes of this part of ISO 90, the following terms and definitions apply. The figures given in this clause illustrate the terminology.

2.1

aerosol can

rigid can made of light gauge metal with a maximum nominal material thickness of 0,49 mm; non-refillable can intended to contain a product which is dispensed by pre-stored pressure in a controlled manner through a valve

2.2 Heights

2.2.1

body height

H_1

height of the body over the double seams (three piece aerosol cans only)

See Figure 1 a).

2.2.2

overall height

H_3

height of the unclosed container

See Figures 1 a) and 1 b).

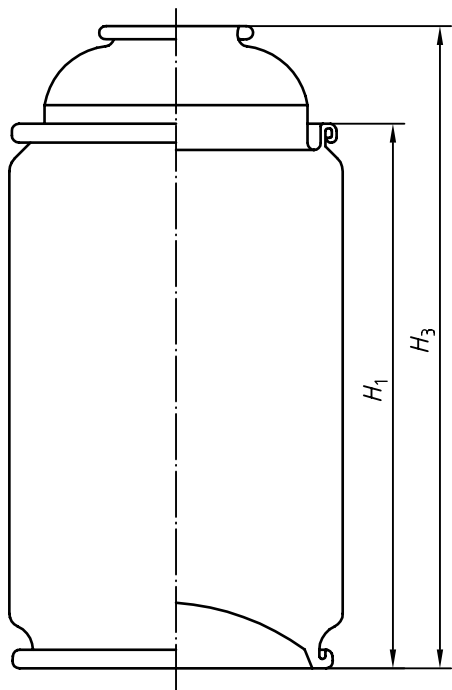

a) Body and overall heights

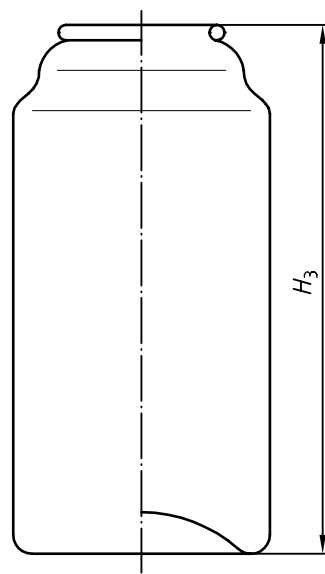

b) Overall height

Figure 1 — Heights

2.3**aperture**

circular opening designed to be sealed by a valve component of which the valve is located in a valve cup

2.4 Constructions**2.4.1****three-piece can**

can made from three main components: body, top end and bottom end

See Figure 2.

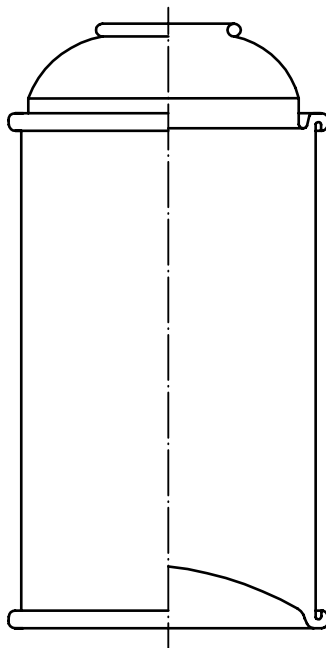

Figure 2 — Three-piece can

2.4.2

two-piece can

(extruded or drawn and wall-ironed) can made from two main components: the body and top end or the body with bottom end

See Figure 3.

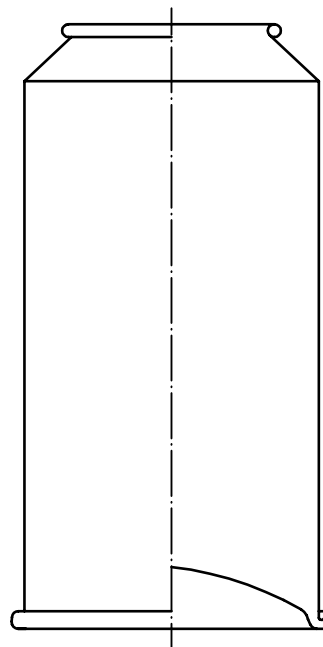
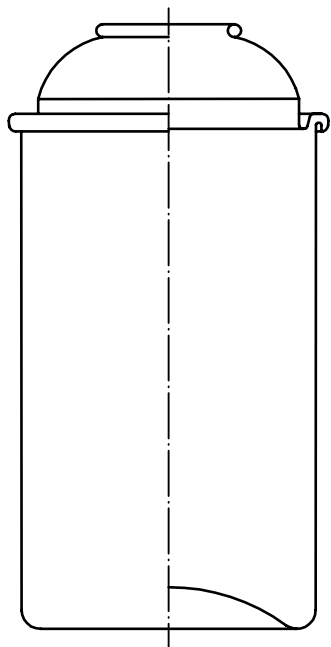

a) Extruded body with bottom (one piece) and top end

b) Drawn and wall-ironed body with shoulder on top (one piece) and bottom end

Figure 3 — Two-piece can

2.4.3

monobloc can

extruded or drawn and wall ironed one-piece can for which a variety of shoulders exists

See Figure 4. Typical shoulders are shown in Figures 4 b) to 4 f).

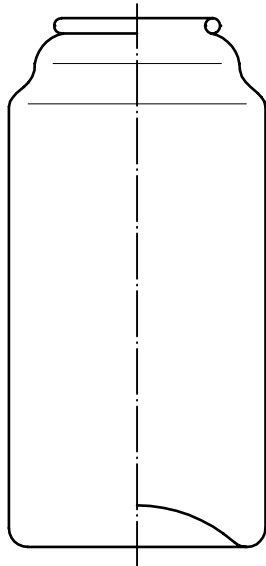

a) Monobloc can

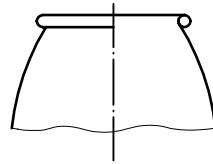

b) Ogival shoulder

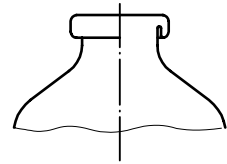

c) Ogival shoulder with reduced opening

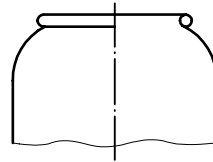

d) Spherical shoulder

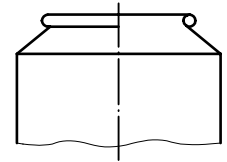

e) Flat shoulder

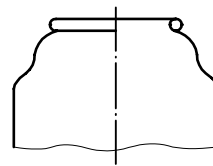

f) Shaped shoulder

Figure 4 — Monobloc can

2.5 Shapes

2.5.1

straight-sided can

can which has a constant diameter from top to bottom, local variations caused by special features being disregarded

See Figure 5.

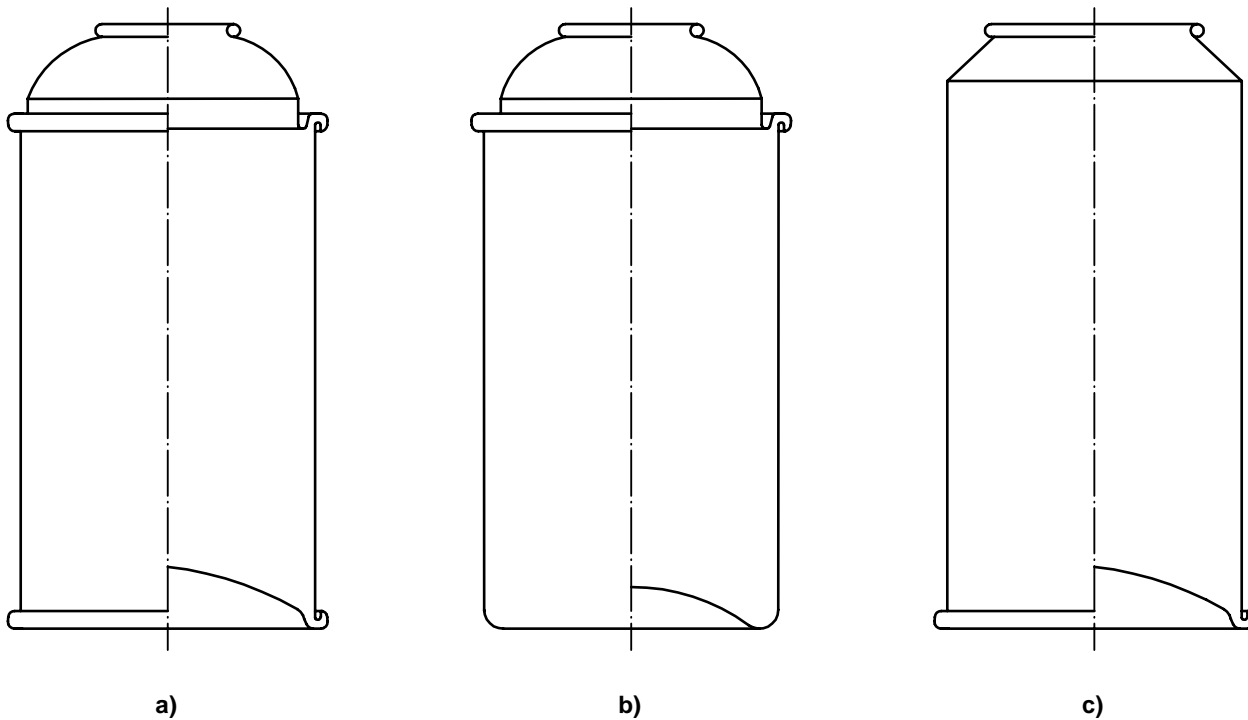

Figure 5 — Straight-sided can

2.5.2 necked-in can

can which has a body reduced diameter at one [see Figures 6 a) and 6 b)] or both [see Figure 6 c)] ends

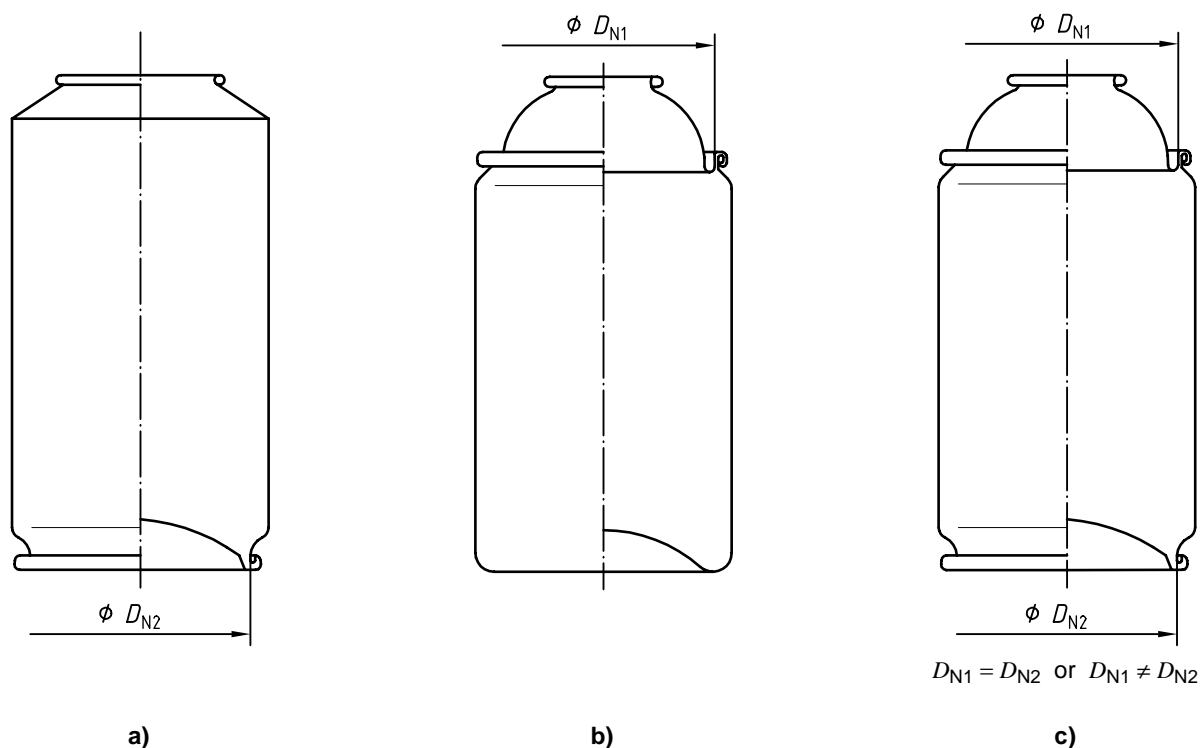

Figure 6 — Necked-in can

2.6 Capacities

2.6.1 gross lidded capacity

C_1

total capacity of a can, fitted with a valve, valve cup and dip tube

NOTE Gross lidded capacity is expressed in millilitres.

2.6.2 brimful capacity

C_2

total capacity of a can without a closure, determined according to 4.2

NOTE Brimful capacity is expressed in millilitres.

3 Determination of dimensions

3.1 Measurement of diameters

3.1.1 Measure the internal body diameter using a plug gauge or derive it from the external diameter.

3.1.2 Measure the external body diameter using a vernier calliper.

3.1.3 Measure the necked-in diameter using a plug gauge applied to the internal diameter of the extremity to which the end is to be fixed.

3.2 Measurement of height

Measure the body height and/or the overall height using a vernier calliper or a height gauge.

3.3 Nominal dimensions

NOTE Annex A gives information on the dimensions of the top end of three-piece necked-in tinplate cans.

3.3.1 Nominal diameters

3.3.1.1 Determination

The nominal diameter is determined by rounding the body or necked-in diameter to the nearest whole millimetre (if the first decimal is 5 or above, round up; in all other cases, round down).

3.3.1.2 Characteristic dimensions

3.3.1.2.1 Aerosol cans

Internal diameter D_i [see Figure 7 a)].

External diameter D_e [see Figure 7 b)].

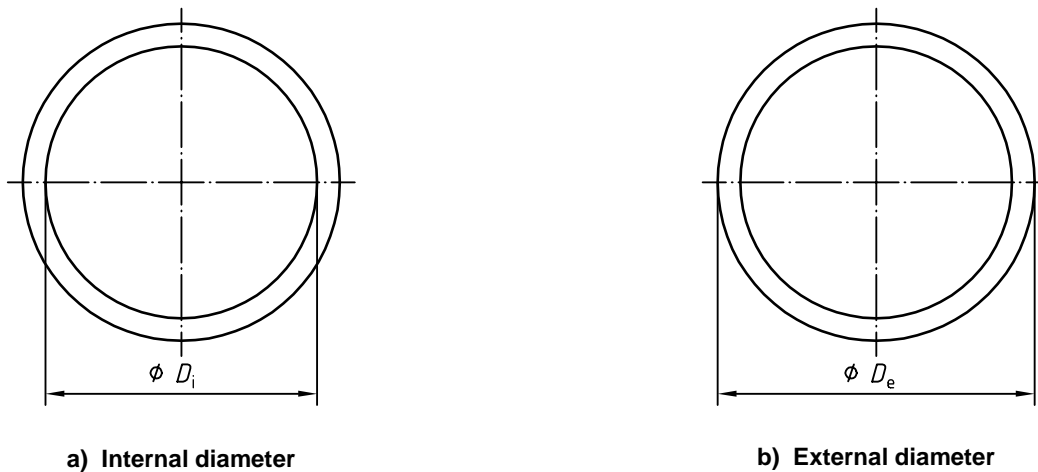

Figure 7 — Diameters

3.3.1.2.2 Necked-in cans

Diameter(s) D_{N1} and/or D_{N2} (see 2.5.2 and Figure 6).

3.3.2 Nominal height

The nominal heights H_1 or H_3 shall be expressed by rounding the height to the nearest whole millimetre (if the first decimal is 5 or above round up; in all other cases, round down).

4 Determination of capacities

4.1 General

The methods for determining capacities all rely on obtaining the mass of water in the can. For cans with a capacity equal to or greater than 400 ml, a correction factor (see 4.1.1) may be applied, but only if a very precise determination of capacity is necessary.

4.1.1 Temperature-dependent correction factor

Table 1 gives the values of correction factors for the determination of capacity with respect to the temperature of water.

Table 1 — Correction factors

Water temperature °C	Correction factor <i>F</i>
12	1,000 5
14	1,000 8
16	1,001 1
18	1,001 4
20	1,001 8
22	1,002 2
24	1,002 7
26	1,003 3
28	1,003 8
30	1,004 4

4.1.2 Accuracy of balances

The scales used for weighing the cans shall not exceed the values of accuracy specified in Table 2.

Table 2 — Balance accuracy

Mass of can <i>m</i> g	Accuracy g
$m \leq 50$	± 0,2
$50 < m \leq 500$	± 0,5
$500 < m$	± 1,0

4.2 Determination of brimful capacity, C_2

4.2.1 Close the can with a rigid disc of transparent plastic with two holes, 3 mm in diameter and about 7 mm apart, or one hole, 6 mm in diameter.

4.2.2 Determine the mass of the empty can together with the disc, m_{d1} , in grams, as accurately as possible (see 4.1.2).

4.2.3 If necessary, measure the temperature of the water to be used (see 4.1.1).

4.2.4 Fill the can with water, avoiding air bubbles.

4.2.5 Close the can with the disc, the hole(s) in the disc being as close as possible to the edge of the aperture, and complete filling through the holes. The can should be shaken, if necessary, during the filling process to ensure the release of any trapped air.

4.2.6 Remove any surplus water from the outside of the can.

4.2.7 Determine the mass of the filled can together with the disc, m_{d2} , in grams, as accurately as possible (see 4.1.2).

4.2.8 The difference between the weighings, $(m_{d2} - m_{d1})$, if necessary multiplied by the relevant correction factor (see 4.1.1), represents the brimful capacity, C_2 , in millilitres, of the can.

5 Tolerances on capacities

5.1 General

For standardized capacities, tolerances are as given in Table 3.

At least 99,7 % of the individual cans shall lie within these limits¹⁾.

5.2 Tolerances

Tolerances for gross lidded or brimful capacities are given in Table 3.

Table 3 — Tolerances on capacities

Gross lidded, C_1 or brimful capacity, C_2 ml	Tolerances	
	%	ml
< 80	± 5	
80 to 100		± 4
101 to 150	± 4	
151 to 200		± 6
201 to 430	± 3	
431 to 650		± 13
651 to 1 000	± 2	
1 001 to 1 400		± 20

¹⁾ This percentage is derived from statistical theory: when a variable, x is distributed according to a normal distribution of parameters μ and σ (where μ is the arithmetical mean and σ is the standard deviation), 99,7 % of its values are between $(\mu - 3\sigma)$ and $(\mu + 3\sigma)$.

6 Designation

It is recommended that aerosol cans be designated internationally in the following manner:

- a) their nominal brimful capacity, C_2 , expressed in millilitres;
- b) their nominal diameters, expressed in millimetres, in accordance with 3.3.1;
- c) their height, expressed in millimetres, in accordance with 2.2 and 3.3.2.

EXAMPLES

Tinplate aerosol cans:

Cylindrical (straight-sided) cans	$C_2 - D_1 - H_1$
Necked-in cans (only top end)	$C_2 - D_1/D_{N1} - H_1$
Necked-in cans (only bottom end)	$C_2 - D_1/D_{N2} - H_1$
Necked-in cans (both ends)	$C_2 - D_1/D_{N1}/D_{N2} - H_1$

Aluminium aerosol cans:

Monobloc cans	$C_2 - D_e - H_3$
---------------	-------------------

© ISO 2000. All rights reserved.

Annex A
(informative)

Dimensions of the top end of three-piece necked-in tinsplate cans

See Figure A.1 for dimensions of the top end of three-piece necked-in tinsplate cans.

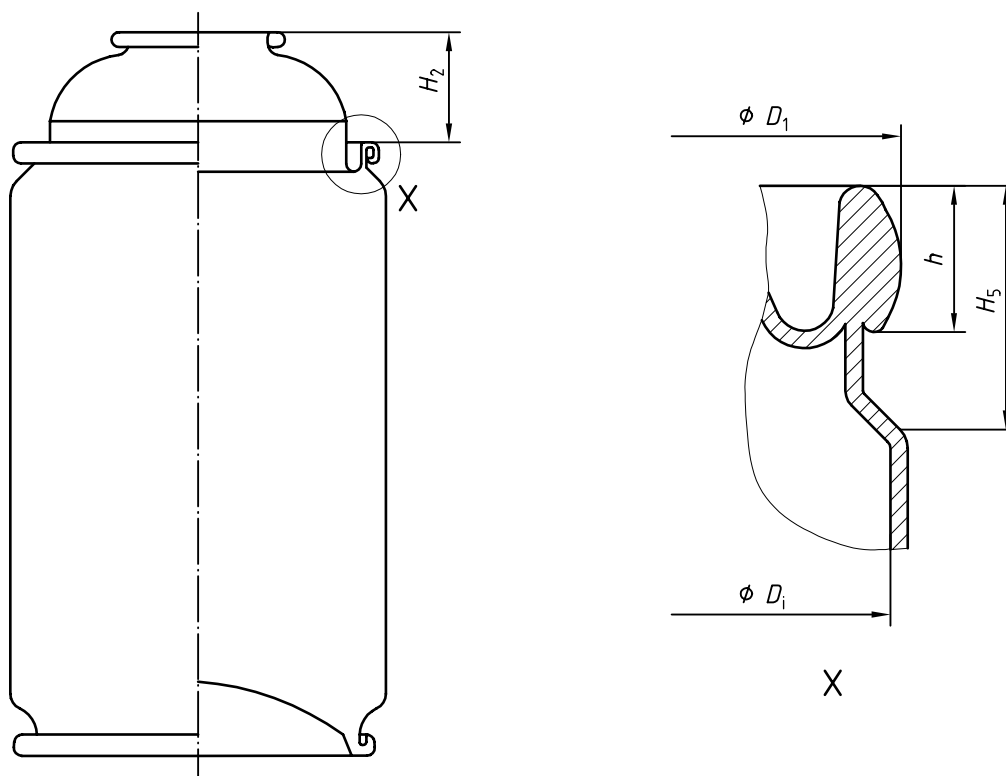

Key

- h Height of the seam
- D_1 External diameter of the seam
- H_2 Height of the top end
- H_5 Height of the neck
- D_i Internal diameter of the body

Figure A.1 — Top end of three-piece necked-in tinsplate can

Bibliography

Related standards dealing with materials used for aerosol cans

- [1] ISO 11949:1995, *Cold-reduced electrolytic tinplate.*
- [2] ISO 11950:1995, *Cold-reduced electrolytic chromium/chromium oxide-coated steel.*
- [3] EN 541:1995, *Aluminium and aluminium alloys — Rolled products for cans, closures and lids — Specifications.*

ICS 55.130

Price based on 13 pages

© ISO 2000 – All rights reserved