

INTERNATIONAL STANDARD

ISO
22

Second edition
1991-12-15

Belt drives — Flat transmission belts and corresponding pulleys — Dimensions and tolerances

*Transmissions par courroies — Courroies plates de transmission et
poulies correspondantes — Dimensions et tolérances*



Reference number
ISO 22:1991(E)

Foreword

ISO (the International Organization for Standardization) is a worldwide federation of national standards bodies (ISO member bodies). The work of preparing International Standards is normally carried out through ISO technical committees. Each member body interested in a subject for which a technical committee has been established has the right to be represented on that committee. International organizations, governmental and non-governmental, in liaison with ISO, also take part in the work. ISO collaborates closely with the International Electrotechnical Commission (IEC) on all matters of electrotechnical standardization.

Draft International Standards adopted by the technical committees are circulated to the member bodies for voting. Publication as an International Standard requires approval by at least 75 % of the member bodies casting a vote.

International Standard ISO 22 was prepared by Technical Committee ISO/TC 41, *Pulleys and belts (including veebelts)*, Sub-Committee SC 1, *Veebelts and grooved pulleys*.

This second edition cancels and replaces the first edition (ISO 22:1975), together with ISO 63:1975, ISO 99:1975 and ISO 100:1984, of which it constitutes a technical revision.

Annexes A and B of this International Standard are for information only.

© ISO 1991

All rights reserved. No part of this publication may be reproduced or utilized in any form or by any means, electronic or mechanical, including photocopying and microfilm, without permission in writing from the publisher.

International Organization for Standardization
Case Postale 56 • CH-1211 Genève 20 • Switzerland

Printed in Switzerland

Belt drives — Flat transmission belts and corresponding pulleys — Dimensions and tolerances

1 Scope

This International Standard specifies the principal dimensions of flat transmission belts and of the corresponding pulleys.

Annexes A and B give, respectively, recommended crowns of the pulleys and the ordinary recommended correspondance between the widths of belts and the widths of the pulleys used.

2 Normative reference

The following standard contains provisions which, through reference in this text, constitute provisions of this International Standard. At the time of publication, the edition indicated was valid. All standards are subject to revision, and parties to agreements based on this International Standard are encouraged to investigate the possibility of applying the most recent edition of the standard indicated below. Members of IEC and ISO maintain registers of currently valid International Standards.

ISO 3:1973, *Preferred numbers — Series of preferred numbers*.

3 Belts

3.1 Length

The lengths specified are the inside lengths under normal fitting tension.

The manufacturer shall take account of the difference between the length under normal fitting tension and the length without tension. This difference depends on the nature of the belt and its method of manufacture.

The belt lengths particularly recommended (preferential series) are given in table 1 and are selected

from the R 20 series of preferred numbers in accordance with ISO 3. The other values are chosen from the R 40 series.

Table 1 — Lengths of belts

Dimensions in millimetres

Preferential series ¹⁾	Secondary series
500	530
560	600
630	670
710	750
800	850
900	950
1 000	1 060
1 120	1 180
1 250	1 320
1 400	1 500
1 600	1 700
1 800	1 900
2 000	
2 240	
2 500	
2 800	
3 150	
3 550	
4 000	
4 500	
5 000	

1) Should the range of lengths given in table 1 be considered insufficient, it may be completed:

- outside the limits, with other terms from the R 20 series of preferred numbers;
- exceptionally, between two consecutive lengths with terms from the R 40 series (from 2 000 mm).

NOTE 1 If required for any technical reason, it is permissible to cut a length of belting and braid it together at the ends to form a belt of any length suitable for a particular application.

3.2 Width

The belt widths and their tolerances are given in table 2. The widths are selected from the R 10 series of numbers in accordance with ISO 3 for values less than or equal to 63 mm and from the R 20 series for higher values.

Table 2 — Widths of belts

Dimensions in millimetres

nom.	Width	tol.
16 20 25 32 40 50 63		± 2
71 80 90 100 112 125		± 3
140 160 180 200 224 250		± 4
280 315 355 400 450 500		± 5

4 Pulleys

4.1 Width

The widths, b , of pulleys and their tolerances are given in table 3. The widths are selected from the R 10 series of preferred numbers in accordance with ISO 3 for values less than or equal to 63 mm, and from the R 20 series for higher values.

Table 3 — Widths of pulleys

Dimensions in millimetres

nom.	b	tol.
20 25 32 40 50 63 71		± 1
80 90 100 112 125 140		$\pm 1,5$
160 180 200 224 250 280		± 2
315 355 400 450 500 560		± 3

4.2 Diameter

The diameter of a pulley for a flat transmission belt is the diameter, D , measured in the plane of symmetry of its rim (see figure A.1).

The diameters, D , of pulleys and their tolerances are given in table 4. The diameters are selected from the R 20 series of preferred numbers in accordance with ISO 3.

Table 4 — Diameters of pulleys

Dimensions in millimetres

nom.	D	tol.
40		$\pm 0,5$
45 50		$\pm 0,6$
56 63		$\pm 0,8$
71 80		± 1
90 100 112		$\pm 1,2$
125 140		$\pm 1,6$
160 180 200		± 2
224 250		$\pm 2,5$
280 315 355		$\pm 3,2$
400 450 500		± 4
560 630 710		± 5
800 900 1 000		$\pm 6,3$
1 120 1 250 1 400		± 8
1 600 1 800 2 000		± 10

Annex A (informative)

Crown

A.1 Shape of crown

It is recommended that the shape of the profile should be a regular, symmetrical curve.

A symmetrical profile with a flat central part is acceptable provided that:

- a) the flat part is tangential to the curve;
- b) its width is not more than 40 % of the width of the pulley.

A.2 Crown height values

The height, h , of the crown of a pulley for a flat transmission belt is given for information in either table A.1 or table A.2 and varies with the diameter D of the pulley (and, for the larger diameters, with the width b of the rim). The crown height may vary according to the materials used for belt construction (the belt manufacturer should be consulted).

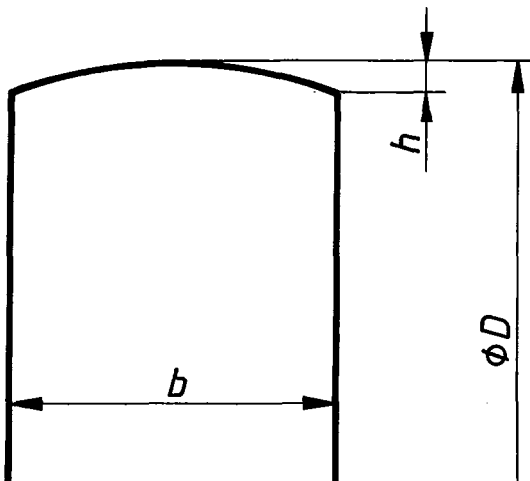

Figure A.1 — Crown of pulleys for flat transmission belts

A.2.1 Pulley diameters $40 \text{ mm} \leq D \leq 710 \text{ mm}$

For this series of pulley diameters, the crown height varies only with the diameter of the pulley and is unrelated to the width of the rim.

Table A.1 — Crown height values

Dimensions in millimetres

Pulley diameter D	Crown h nom.
$40 \leq D \leq 112$	0,3
$125 \leq D \leq 140$	0,4
$160 \leq D \leq 180$	0,5
$200 \leq D \leq 224$	0,6
$250 \leq D \leq 280$	0,8
$315 \leq D \leq 355$	1
$400 \leq D \leq 500$	1
$560 \leq D \leq 710$	1,2

A.2.2 Pulley diameters

$800 \text{ mm} \leq D \leq 2\,000 \text{ mm}$

For this series of pulley diameters, the crown height varies with both the diameter of the pulley and the width.

Table A.2 — Crown height values

Dimensions in millimetres

Pulley diameter D	Width	
	$b \leq 250$	$b \geq 280$
Crown h nom.		
$800 \leq D \leq 1\,000$	1,2	1,5
$1\,120 \leq D \leq 1\,400$	1,5	2
$1\,600 \leq D \leq 2\,000$	1,8	2,5

Annex B
(informative)

Ordinary recommended correspondance between belt widths and pulley widths

Table B.1 — Ordinary recommended correspondance

Dimensions in millimetres

Belt width	Pulley width
16 20 25 32 40 50 63	20 25 32 40 50 63 71
71 80 90 100 112 125	80 90 100 112 125 140
140 160 180 200 224 250	160 180 200 224 250 280
280 315 355 400 450 500	315 355 400 450 500 560

NOTE — If, for any technical reason, it is preferable to use a wider pulley for a particular belt, as frequently occurs with the narrower belts, such a pulley may be chosen from the series of pulleys given in table 3.

UDC 621.85.052.41:621.85.051

Descriptors: belt drives, belts, power transmission belts, pulleys, dimensions, dimensional tolerances.

Price based on 5 pages
