International Standard



21

INTERNATIONAL ORGANIZATION FOR STANDARDIZATION • МЕЖДУНАРОДНАЯ ОРГАНИЗАЦИЯ ПО СТАНДАРТИЗАЦИИ • ORGANISATION INTERNATIONALE DE NORMALISATION

Shipbuilding — Inland navigation — Cable-lifters for stud-link anchor chains

Construction navale — Navigation intérieure — Barbotins pour les chaînes d'ancre étançonnées

Second edition — 1985-06-15

UDC 629.122.015.64

Ref. No. ISO 21-1985 (E)

Descriptors : shipbuilding, inland navigation, ships, ships anchors, chains, windlasses, dimensions, designation.

Foreword

ISO (the International Organization for Standardization) is a worldwide federation of national standards bodies (ISO member bodies). The work of preparing International Standards is normally carried out through ISO technical committees. Each member body interested in a subject for which a technical committee has been established has the right to be represented on that committee. International organizations, governmental and non-governmental, in liaison with ISO, also take part in the work.

Draft International Standards adopted by the technical committees are circulated to the member bodies for approval before their acceptance as International Standards by the ISO Council. They are approved in accordance with ISO procedures requiring at least 75 % approval by the member bodies voting.

International Standard ISO 21 was prepared by Technical Committee ISO/TC 8, *Shipbuilding and marine structures*.

ISO 21 was first published in 1983. This second edition cancels and replaces the first edition, the basic dimensions table of which has been revised technically.

Shipbuilding — Inland navigation — Cable-lifters for stud-link anchor chains

1 Scope and field of application

This International Standard specifies types and basic dimensions of cable-lifters for stud-link anchor chains used on inland vessels.

2 Reference

ISO 1704, *Shipbuilding — Stud-link anchor chains*.¹⁾

3 Types

Cable-lifters are identified in three types:

- A — with five snugs
- B — with six snugs
- C — with seven snugs

4 Dimensions

Basic dimensions of cable-lifters shall correspond to those indicated in the figure and in the table.

5 Materials

Cable-lifters shall be manufactured of materials meeting the requirements of classification societies.

6 Manufacture

6.1 Proper bedding of the cable in the cable-lifter remains the manufacturer's responsibility.

6.2 Proper functioning of the windlass cable-lifter is to be verified during the ship's anchor trials.

7 Designation

The designation of cable-lifters in accordance with this International Standard shall contain the following elements in the order given:

- a) name: cable-lifter;
- b) number of this International Standard: ISO 21;
- c) type: see clause 3;
- d) chain-link nominal diameter: see the table.

Example:

A cable-lifter in accordance with this International Standard with five snugs, chain-link nominal diameter $d = 16$ mm shall be designated as follows:

Cable-lifter ISO 21 - A16

1) At present at the stage of draft. (Revision of ISO 1704-1973.)

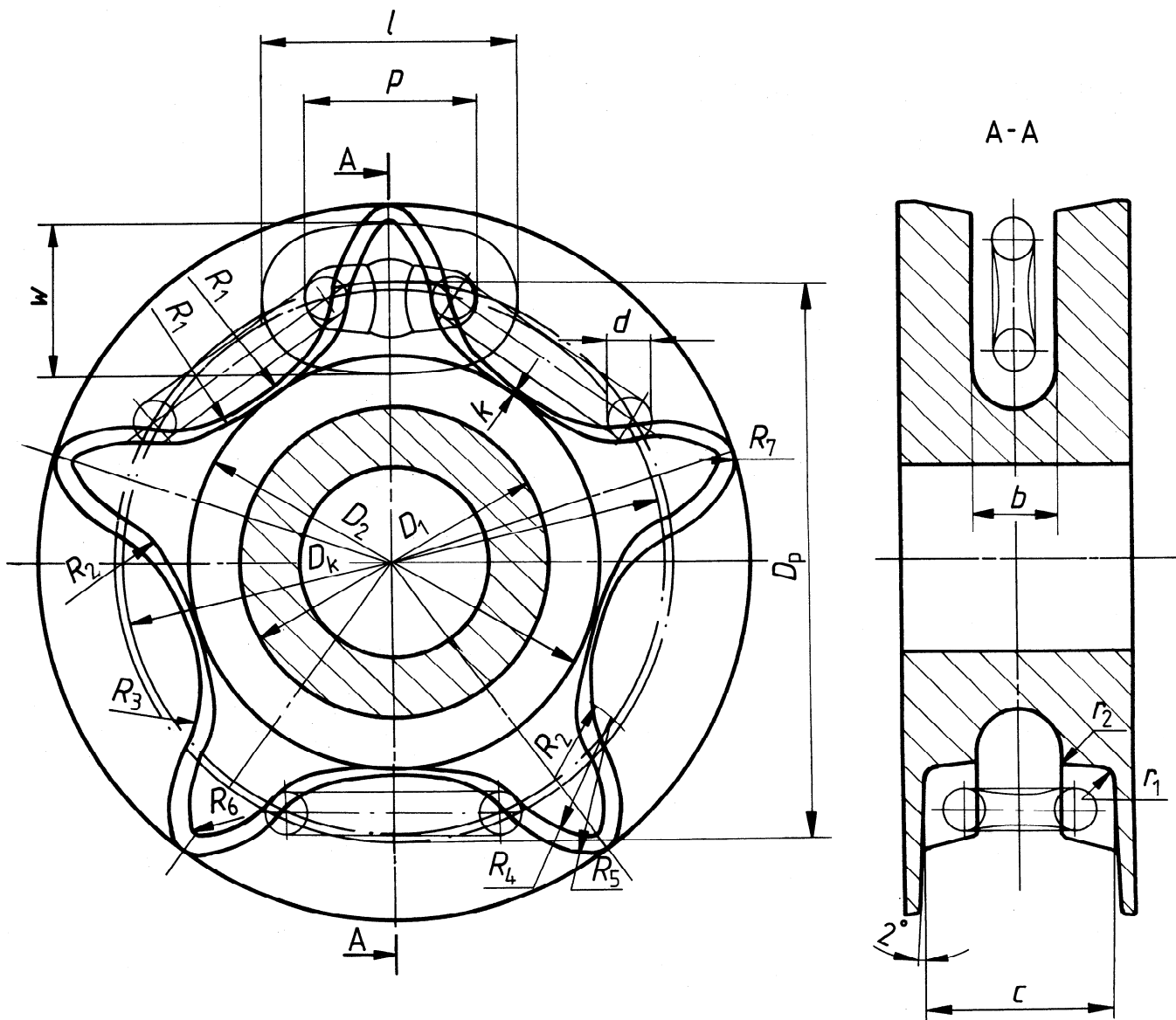

Figure — Cable-lifters for stud-link anchor chains

Table — Basic dimensions of cable-lifters for stud-link anchor chains

Dimensions in millimetres

Link ¹⁾				Cable-lifter																	
<i>d</i>	<i>l</i>	<i>p</i>	<i>w</i>	Type	<i>n</i> ²⁾	<i>D_p</i>	<i>D_k</i>	<i>D₁</i>	<i>D₂</i>	<i>R₁</i>	<i>R₂</i>	<i>R₃</i>	<i>R₄</i>	<i>R₅</i>	<i>R₆</i>	<i>R₇</i>	<i>r₁</i>	<i>r₂</i>	<i>k</i>	<i>b</i>	<i>c</i>
1	2	3	4	5	6	7	8	9	10	11	12	13	14	15	16	17	18	19	20	21	22
11	66	44	40	A	5	143	139	81	108	110	22	30	32	36	3	7	3,5	1,5	1,5	18	53
				B	6	170	166	109	137												
				C	7	198	193	126	160												
12,5	75	50	45	A	5	162	158	92	122	125	25	34	37	41	3	8	4	1,5	1,5	21	60
				B	6	194	189	124	156												
				C	7	225	219	144	181												
14	84	56	50	A	5	182	177	103	137	140	28	38	41	46	4	9	4,5	2	2	23,5	68
				B	6	217	200	131	166												
				C	7	252	246	161	203												
16	96	64	58	A	5	208	203	117	157	160	32	44	47	53	4	11	5	2	2	27	78
				B	6	248	242	158	200												
				C	7	288	281	184	232												
17,5	105	70	63	A	5	227	222	128	171	175	35	48	51	58	4,5	12	6	2	2	29	85,5
				B	6	271	264	173	219												
				C	7	316	308	202	255												
19	114	76	68	A	5	247	241	139	186	190	38	52	56	63	5	13	6	2,5	2,5	32	93
				B	6	294	287	188	237												
				C	7	341	332	218	275												
20,5	123	82	74	A	5	266	260	150	201	205	41	56	60	68	5,5	14	7	3	3	34,5	100
				B	6	317,5	309	203	252												
				C	7	369	360	236	298												
22	132	88	79	A	5	286	279	162	215	220	44	60	64	73	6	15	7	3	3	37	107
				B	6	341	332	237	275												
				C	7	396	386	253	319												
24	144	96	86	A	5	312	304	176	235	240	48	65	70	79	6	16	8	3	3	40,5	117
				B	6	372	362	238	300												
				C	7	433	422	277	349												
26	156	104	94	A	5	338	329	191	254	260	52	71	76	86	7	17	9	3,5	3,5	43	127
				B	6	403	392	257	325												
				C	7	468	456	299	377												
28	168	112	101	A	5	364	355	206	274	280	56	76	82	92	7	19	9	4	3,5	47	137
				B	6	434	423	277	350												
				C	7	505	492	323	407												
30	180	120	108	A	5	390	380	220	294	300	60	82	88	99	8	20	10	4	4	50,5	147
				B	6	465	453	297	375												
				C	7	539	523	344	435												
32	192	128	115	A	5	415	405	235	313	320	64	87	94	106	8,5	21	11	4	4	54	157
				B	6	496	483	317	400												
				C	7	576	561	368	465												
34	204	136	122	A	5	441	431	250	333	340	68	93	100	112	9	23	11	4,5	4,5	57	167
				B	6	526,5	513	337	425												
				C	7	613	597	392	494												

Table — Basic dimensions of cable-lifters for stud-link anchor chains (concluded)

Dimensions in millimetres

Link ¹⁾				Cable-lifter																	
<i>d</i>	<i>l</i>	<i>p</i>	<i>w</i>	Type	<i>n</i> ²⁾	<i>D_p</i>	<i>D_k</i>	<i>D₁</i>	<i>D₂</i>	<i>R₁</i>	<i>R₂</i>	<i>R₃</i>	<i>R₄</i>	<i>R₅</i>	<i>R₆</i>	<i>R₇</i>	<i>r₁</i>	<i>r₂</i>	<i>k</i>	<i>b</i>	<i>c</i>
1	2	3	4	5	6	7	8	9	10	11	12	13	14	15	16	17	18	19	20	21	22
36	216	144	130	A	5	467,5	456	264	352	360	72	98	105	118	9,5	24	12	5	5	60,5	177
				B	6	557,5	543	356	450												
				C	7	648	632	414	523												
38	228	152	137	A	5	493,5	481	279	372	380	76	104	111	125	10	25	13	5	5	64	187
				B	6	588,5	574	376	475												
				C	7	684	667	437	552												
40	240	160	144	A	5	519,5	507	294	392	400	80	109	117	132	11	27	13	5	5	67,5	197
				B	6	619,5	604	396	500												
				C	7	721	703	461	581												
42	252	168	151	A	5	545	532	308	411	420	84	115	123	139	11	28	14	5,5	5,5	69	204
				B	6	650	633	415	524												
				C	7	756	737	483	610												
44	264	176	158	A	5	572	558	323	431	440	88	120	129	145	12	29	15	6	6	73	213
				B	6	682	665	436	550												
				C	7	793	773	507	640												

1) Principal dimensions: *d* = nominal diameter of link (column 1)
l = length of link (column 2)
p = pitch of link (column 3)
w = width of link (column 4)

2) *n* = number of snugs

This page intentionally left blank

This page intentionally left blank