**Pipe threads where pressure-tight joints are
made on the threads —**

Part 2:
Verification by means of limit gauges

*Filetages de tuyauterie pour raccordement avec étanchéité dans le filet —
Partie 2: Vérification par calibres à limites*



Reference number
ISO 7-2:2000(E)

© ISO 2000

PDF disclaimer

This PDF file may contain embedded typefaces. In accordance with Adobe's licensing policy, this file may be printed or viewed but shall not be edited unless the typefaces which are embedded are licensed to and installed on the computer performing the editing. In downloading this file, parties accept therein the responsibility of not infringing Adobe's licensing policy. The ISO Central Secretariat accepts no liability in this area.

Adobe is a trademark of Adobe Systems Incorporated.

Details of the software products used to create this PDF file can be found in the General Info relative to the file; the PDF-creation parameters were optimized for printing. Every care has been taken to ensure that the file is suitable for use by ISO member bodies. In the unlikely event that a problem relating to it is found, please inform the Central Secretariat at the address given below.

© ISO 2000

All rights reserved. Unless otherwise specified, no part of this publication may be reproduced or utilized in any form or by any means, electronic or mechanical, including photocopying and microfilm, without permission in writing from either ISO at the address below or ISO's member body in the country of the requester.

ISO copyright office
Case postale 56 • CH-1211 Geneva 20
Tel. + 41 22 749 01 11
Fax + 41 22 749 09 47
E-mail copyright@iso.ch
Web www.iso.ch

Printed in Switzerland

Contents

Page

Foreword.....	iv
Introduction	v
1 Scope	1
2 Normative reference	1
3 Terms and definitions	1
4 Symbols	2
5 Design of gauges	3
5.1 General.....	3
5.2 Taper full form threaded plug gauges (gauges No. 1 and No. 2).....	4
5.3 Parallel full form threaded ring gauge (gauge No. 3).....	8
5.4 Taper plain ring gauge (gauge No. 4)	10
5.5 Taper modified thread form check plug gauge (gauge No. 5)	11
5.6 Parallel modified thread form check ring gauge (gauge No. 6)	13
6 Use of gauges and checking of pipe threads	14
6.1 General.....	14
6.2 Checking of internal taper (Rc) and internal parallel (Rp) threads.....	15
6.3 Checking of external taper (R) threads	16
7 Gauge dimensions and manufacturing tolerances, checking of new gauges and checking gauges for wear	17
7.1 Gauge dimensions and manufacturing tolerances	17
7.2 Checking of new gauges.....	23
7.3 Checking gauges for wear	26
7.4 Marking of gauges	28
Annex A (normative) Summary of gauges.....	29

Foreword

ISO (the International Organization for Standardization) is a worldwide federation of national standards bodies (ISO member bodies). The work of preparing International Standards is normally carried out through ISO technical committees. Each member body interested in a subject for which a technical committee has been established has the right to be represented on that committee. International organizations, governmental and non-governmental, in liaison with ISO, also take part in the work. ISO collaborates closely with the International Electrotechnical Commission (IEC) on all matters of electrotechnical standardization.

International Standards are drafted in accordance with the rules given in the ISO/IEC Directives, Part 3.

Draft International Standards adopted by the technical committees are circulated to the member bodies for voting. Publication as an International Standard requires approval by at least 75 % of the member bodies casting a vote.

Attention is drawn to the possibility that some of the elements of this part of ISO 7 may be the subject of patent rights. ISO shall not be held responsible for identifying any or all such patent rights.

International Standard ISO 7-2 was prepared by Technical Committee ISO/TC 5, *Ferrous metal pipes and metallic fittings*, Subcommittee SC 5, *Threaded or plain end butt-welding fittings, gauging of threads*.

This second edition cancels and replaces the first edition (ISO 7-2:1982), which has been technically revised.

ISO 7 consists of the following parts, under the general title *Pipe threads where pressure-tight joints are made on the threads*:

- *Part 1: Dimensions, tolerances and designation*
- *Part 2: Verification by means of limit gauges*

Annex A forms a normative part of this part of ISO 7.

Introduction

This revision of ISO 7-2 has been undertaken with the aim of providing a unified gauging system which could be adopted worldwide and thus eliminate the differing gauging results obtained with the use of gauges in accordance with ISO 7-2:1982 and existing national practices. This revision also includes details of plain ring gauges to provide additional means of checking ISO 7-1 external threads and a parallel modified thread form check ring gauge for checking taper full form threaded plug gauges.

Pipe threads where pressure-tight joints are made on the threads —

Part 2: Verification by means of limit gauges

1 Scope

This part of ISO 7 specifies a process using limit gauges, for the validation of taper internal and external threads and parallel internal threads on piping systems components and other products, the dimensions and tolerances of which are detailed in ISO 7-1.

The gauging system described may not be suitable, without special precautions, for gauging of threads on injection moulded plastic workpieces.

This part of ISO 7 does not cover completely all the requirements necessary for full control of thread quality and dimensions. Additional control of tools and equipment and visual inspection during production are required to ensure complete compliance with ISO 7-1, for example the length of useful thread on internally threaded workpieces should be checked by direct measurement.

Annex A gives a summary of the gauges included in this part of ISO 7, together with details of the thread elements controlled by each gauge and gauge identification numbers.

In the event of a dispute over compliance with the requirements of ISO 7-1, the gauges in this part of ISO 7 are to be considered as decisive for the thread elements which they control on the workpiece.

2 Normative reference

The following normative document contains provisions which, through reference in this text, constitute provisions of this part of ISO 7. For dated references, subsequent amendments to, or revisions of, any of these publications do not apply. However, parties to agreements based on this part of ISO 7 are encouraged to investigate the possibility of applying the most recent edition of the normative document indicated below. For undated references, the latest edition of the normative document referred to applies. Members of ISO and IEC maintain registers of currently valid International Standards.

ISO 7-1:1994, *Pipe threads where pressure-tight joints are made on the threads — Part 1: Dimensions, tolerances and designation.*

3 Terms and definitions

For the purposes of this part of ISO 7, the terms and definitions given in ISO 7-1 and the following apply.

3.1 accommodation length

distance from the face of an internally threaded workpiece to the first obstruction which the externally threaded workpiece will encounter on assembly

See Figure 3.

4 Symbols

The symbols used and their explanations are given in Table 1.

Table 1 — Symbols

Symbol	Explanation
b_1	Width of clearance groove at major diameter of parallel full form threaded ring gauges and minor diameter of taper full form threaded plug gauges
b_2	Width of clearance groove at major diameter of parallel modified thread form check ring gauges and at minor diameter of taper modified thread form check plug gauges
c	Height of tolerance step on plug gauges
D	Major diameter of internal thread at gauge plane
D_1	Minor diameter of internal thread at gauge plane
D_2	Pitch diameter of internal thread at gauge plane
D_4	Counterbore diameter of parallel full form threaded ring gauge and taper plain ring gauge
d	Major diameter of external thread at gauge plane
d_1	Minor diameter of external thread at gauge plane
d_2	Pitch diameter of external thread at gauge plane
F	Radial distance from the pitch diameter to the truncated crest, along the centreline of the thread profile
l_0	Overall length of taper full form threaded plug gauge and taper modified thread form check plug gauge
l_1	Length from end face to the gauge plane on taper full form threaded plug gauge
l_2	Length of tolerance step on plug gauges
l_3	Overall length of parallel full form threaded ring gauge, parallel modified thread form check ring gauge and length from gauge plane to small end of taper plain ring gauge
l_4	Length of tolerance step on ring gauges
l_5	Depth of counterbore on parallel full form threaded ring gauge
l_6	Overall length of taper full form threaded plug gauge with relief
l_7	Width of relief on taper full form threaded plug gauge with relief
l_8	Length from relief on taper full form threaded plug gauge with relief to large end of gauge
l_9	Overall length of taper plain ring gauge
l_{10}	Depth of counterbore on taper plain ring gauge
l_{11}	Distance from step on gauge Nos. 1 and 2 to face of gauge No. 6 when verifying pitch diameter of new gauge Nos. 1 and 2
l_{12}	Distance from step on gauge No. 5 to face of gauge No. 6 when verifying pitch diameter of new gauge No. 6
l_{13}	Distance from step on gauge Nos. 1 and 2 to face of gauge No. 6 when checking pitch diameter of gauge Nos. 1 and 2 for wear

Table 1 (concluded)

Symbol	Explanation
l_{14}	Distance from step on gauge No. 5 to face of gauge No. 3 when checking pitch diameter of gauge No. 3 for wear
P	Pitch
$T_{\alpha 1/2}$	Tolerance on flank angle of full form threads
$T_{\alpha 2/2}$	Tolerance on flank angle of modified form threads
T_{CP}	Tolerance on pitch diameter for taper modified thread form check plug gauge and parallel modified thread form check ring gauge
T_P	Tolerance on pitch
T_{PL}	Tolerance on pitch diameter and wear allowance for taper full form threaded plug gauges
T_R	Tolerance on pitch diameter and wear allowance for parallel full form threaded ring gauge and tolerance on diameter and wear allowance for taper plain ring gauge
T_1	Tolerance on the gauge length of an external thread
T_2	Tolerance on position of gauge plane on an internal thread
W	Permissible wear on diameter of all gauges except taper modified thread form check plug gauges
NOTE The values of D , D_1 , D_2 , d , d_1 and d_2 shown in Table 2 to Table 7 are basic values and are subject to the manufacturing tolerances specified in clause 7.	

5 Design of gauges

5.1 General

The taper full form threaded plug gauges and parallel full form threaded ring gauges (see 5.2 and 5.3) together with the taper plain ring gauges (see 5.4) have been chosen as representing the requirements for mating components or products within the tolerances of ISO 7-1.

Because of the 1:16 taper of the gauge and/or the threaded workpiece, it is possible to represent the maximum and minimum limits of diameter by means of tolerance steps within the axial length of the gauges.

The plain ring gauges included in this part of ISO 7, allow a combined check of the major diameter and the length of useful thread of externally threaded workpieces.

The taper modified thread form check plug gauge (see 5.5) and parallel modified thread form check ring gauge (see 5.6) for checking the manufacturing tolerances and wear allowances for the parallel full form threaded ring gauges and taper full form threaded plug gauges respectively, are made to a modified thread form.

Some dimensions given in this part of ISO 7 are more precise than the equivalent dimensions given in ISO 7-1. This greater precision is only intended to assist the gauge manufacturing process and is of no practical significance when using the gauges.

NOTE The expression "full form" has been used to describe those threaded plug and ring gauges which may be full form or alternatively have thread form relief at the discretion of the manufacturer, so as to differentiate from those threaded check plug and check ring gauges which are always of modified thread form.

5.2 Taper full form threaded plug gauges (gauges No. 1 and No. 2)

5.2.1 Taper full form threaded plug gauge (gauge No. 1)

This gauge is a 1:16 taper full form threaded plug gauge (see Figure 1) and is suitable for checking the major diameter (D) and pitch diameter (D_2) at the gauge plane of internal parallel (Rp) threads and internal taper (Rc) threads.

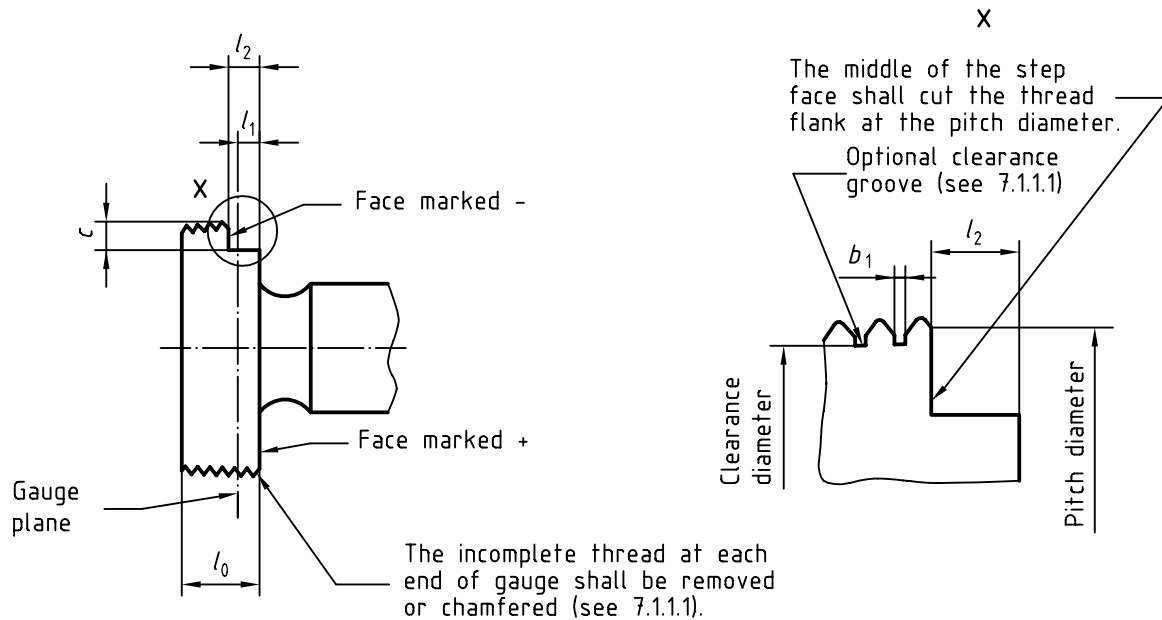

Figure 1 — Taper full form threaded plug gauge (gauge No. 1)

The dimensions of this gauge are given in Table 2 and manufacturing tolerances are given in 7.1.1.2.

The gauge incorporates a step equal in length to the total tolerance T_2 on the position of the gauge plane of the internal thread specified in ISO 7-1. To allow for the chamfer on the internal thread, the step is displaced by $0,5P$ relative to the gauge plane, such that the internally threaded workpiece can be verified with reference to its face.

The large diameter end face of the gauge is marked '+' (positive) and the face of the tolerance step is marked '-' (negative).

NOTE For sizes smaller than 1/2, the '+' and '-' markings may be omitted if not practicable.

Table 2 — Dimensions of taper full form threaded plug gauge (gauge No. 1)

Dimensions in millimetres

Designation of thread	Pitch <i>P</i>	Diameters at gauge plane			Overall length of gauge <i>l</i> ₀	Length from end face to the gauge plane <i>l</i> ₁	Length of tolerance step <i>l</i> ₂	Width of clearance groove <i>b</i> ₁ max.	Height of step <i>c</i>
		major <i>d, D</i>	Pitch <i>d</i> ₂ , <i>D</i> ₂	minor <i>d</i> ₁ , <i>D</i> ₁					
1	2	3	4	5	6	7	8	9	10
1/16	0,907	7,723	7,142	6,561	5,6	1,588	2,268	0,3	1,8
1/8	0,907	9,728	9,147	8,566	5,6	1,588	2,268	0,3	1,8
1/4	1,337	13,157	12,301	11,445	8,4	2,339	3,342	0,4	2,4
3/8	1,337	16,662	15,806	14,950	8,8	2,339	3,342	0,4	2,4
1/2	1,814	20,955	19,793	18,631	11,4	3,175	4,536	0,5	3,3
3/4	1,814	26,441	25,279	24,117	12,7	3,175	4,536	0,5	4,5
1	2,309	33,249	31,770	30,291	14,5	4,041	5,773	0,6	5,8
1 1/4	2,309	41,910	40,431	38,952	14,5	4,041	5,773	0,6	5,8
1 1/2	2,309	47,803	46,324	44,845	14,5	4,041	5,773	0,6	5,8
2	2,309	59,614	58,135	56,656	15	4,041	5,773	0,6	5,8
2 1/2	2,309	75,184	73,705	72,226	17,5	4,618	6,927	0,6	6,9
3	2,309	87,884	86,405	84,926	18,5	4,618	6,927	0,6	6,9
4	2,309	113,030	111,551	110,072	20	4,618	6,927	0,6	6,9
5	2,309	138,430	136,951	135,472	24	4,618	6,927	0,6	10
6	2,309	163,830	162,351	160,872	24	4,618	6,927	0,6	10

NOTE The values given in columns 3, 4 and 5 are basic values intended for the calculation of diameters at the gauge plane in accordance with 7.1.1.

5.2.2 Taper full form threaded plug gauge with relief (gauge No. 2)

This gauge is a 1:16 taper full form threaded plug gauge with relief of threads (see Figure 2) and is suitable for checking the major diameter (*D*) and pitch diameter (*D*₂) at the gauge plane, and the accommodation length (see Figure 3) of internal parallel (Rp) threads and internal taper (Rc) threads.

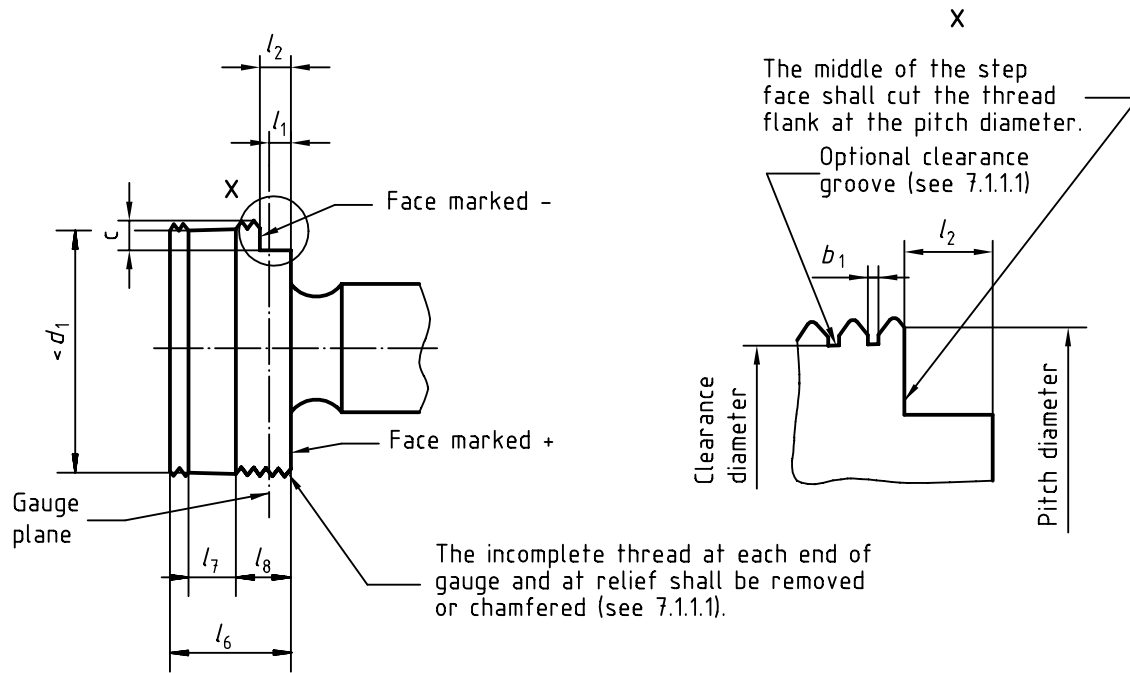
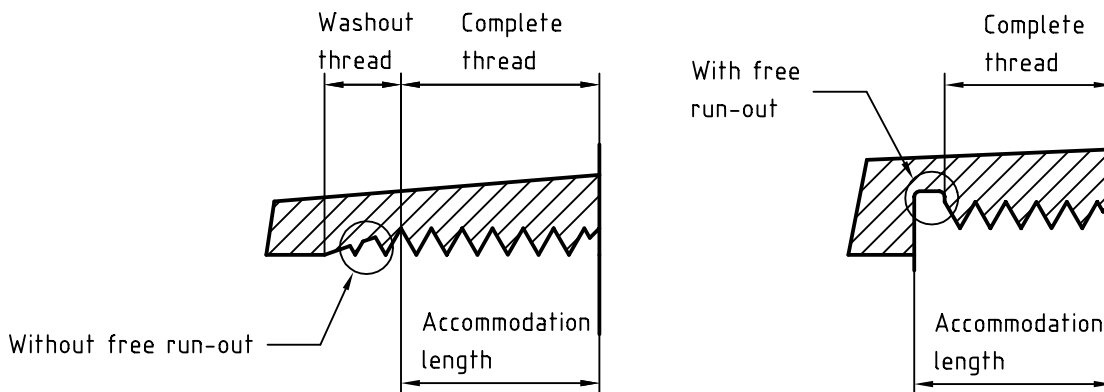

Figure 2 — Taper full form threaded plug gauge with relief (gauge No. 2)



NOTE Figure 3 is applicable to internal parallel (Rp) threads and internal taper (Rc) threads.

Figure 3 — Accommodation length

The dimensions of this gauge are given in Table 3 and manufacturing tolerances are given in 7.1.1.2.

The gauge incorporates a step equal in length to the total tolerance T_2 on the position of the gauge plane of the internal thread specified in ISO 7-1. To allow for the chamfer on the internal thread, the step is displaced by $0,5P$ relative to the gauge plane, such that the internally threaded workpiece can be checked with reference to its face. On sizes 1/4 and larger, a thread relief is provided part way along the gauge, thereby reducing the number of threads and consequential friction in contact with the internally threaded workpiece.

The overall length (l_6) of the gauge is equal to the length of useful thread for maximum gauge length plus $0,5P$.

The large diameter end face of the gauge is marked '+' (positive) and the face of the tolerance step is marked '-' (negative).

NOTE For sizes smaller than 1/2, the '+' and '-' markings may be omitted if not practicable.

Table 3 — Dimensions of taper full form threaded plug gauge with relief (gauge No. 2)

Dimensions in millimetres

Designation of thread	Pitch <i>P</i>	Diameters at gauge plane			Length from end face to the gauge plane <i>l</i> ₁	Length of tolerance step <i>l</i> ₂	Overall Length of gauge <i>l</i> ₆	Width of relief <i>l</i> ₇	Length from relief to large end of gauge <i>l</i> ₈	Width of clearance groove <i>b</i> ₁ max.	Height of step <i>c</i>
		major <i>d, D</i>	pitch <i>d</i> ₂ , <i>D</i> ₂	Minor <i>d</i> ₁ , <i>D</i> ₁							
1	2	3	4	5	6	7	8	9	10	11	12
1/16	0,907	7,723	7,142	6,561	1,588	2,268	7,823	—	—	0,3	1,8
1/8	0,907	9,728	9,147	8,566	1,588	2,268	7,823	—	—	0,3	1,8
1/4	1,337	13,157	12,301	11,445	2,339	3,342	11,699	2,3	5,3	0,4	2,4
3/8	1,337	16,662	15,806	14,950	2,339	3,342	12,033	2,7	5,3	0,4	2,4
1/2	1,814	20,955	19,793	18,631	3,175	4,536	15,872	3,2	7,3	0,5	3,3
3/4	1,814	26,441	25,279	24,117	3,175	4,536	17,233	4,5	7,3	0,5	4,5
1	2,309	33,249	31,770	30,291	4,041	5,773	20,204	4,1	9,2	0,6	5,8
1 1/4	2,309	41,910	40,431	38,952	4,041	5,773	22,513	6,4	9,2	0,6	5,8
1 1/2	2,309	47,803	46,324	44,845	4,041	5,773	22,513	6,4	9,2	0,6	5,8
2	2,309	59,614	58,135	56,656	4,041	5,773	26,842	10,7	9,2	0,6	5,8
2 1/2	2,309	75,184	73,705	72,226	4,618	6,927	31,316	14	10,4	0,6	6,9
3	2,309	87,884	86,405	84,926	4,618	6,927	34,491	17,1	10,4	0,6	6,9
4	2,309	113,030	111,551	110,072	4,618	6,927	40,407	23,1	10,4	0,6	6,9
5	2,309	138,430	136,951	135,472	4,618	6,927	44,737	27,4	10,4	0,6	10
6	2,309	163,830	162,351	160,872	4,618	6,927	44,737	27,4	10,4	0,6	10

NOTE The values given in columns 3, 4 and 5 are basic values intended for the calculation of diameters at the gauge plane in accordance with 7.1.1.

5.3 Parallel full form threaded ring gauge (gauge No. 3)

This gauge is a parallel full form threaded ring gauge (see Figure 4) and is suitable for checking the minor diameter (d_1) and pitch diameter (d_2) at the gauge plane of taper external (R) threads.

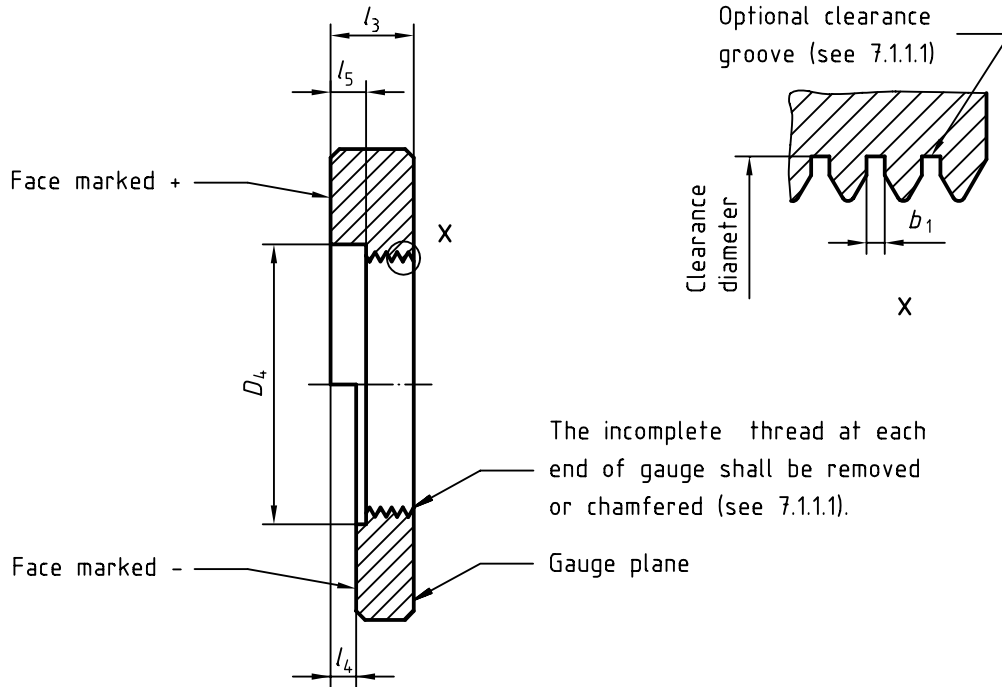

Figure 4 — Parallel full form threaded ring gauge (gauge No. 3)

The dimensions of this gauge are given in Table 4 and manufacturing tolerances are given in 7.1.1.2.

The gauge incorporates a step equal to the total tolerance T_1 on gauge length, specified in ISO 7-1. The step is situated between minimum and maximum gauge lengths measured from the gauge plane and is counterbored for the diameter D_4 to a depth l_5 .

The gauge plane is located at the face of the gauge, opposite to the step.

The overall length (l_3) of the gauge corresponds to the maximum gauge length.

The outer and inner faces of the tolerance step shall be marked '+' (positive) and '-' (negative) respectively.

NOTE These signs indicate the maximum and minimum gauge lengths, respectively the corresponding minimum and maximum allowable diameters of the external thread.

Table 4 — Dimensions of parallel full form threaded ring gauge (gauge No. 3)

Dimensions in millimetres

Designation of thread	Pitch P	Diameters at gauge plane			Width of clearance groove b_1 max.	Diameter of counter-bore D_4	Overall length of gauge l_3	Length of tolerance step l_4	Depth of counter-bore l_5
		major D, d	pitch D_2, d_2	minor D_1, d_1					
1	2	3	4	5	6	7	8	9	10
1/16	0,907	7,723	7,142	6,561	0,3	9,5	4,876	1,814	2
1/8	0,907	9,728	9,147	8,566	0,3	11,5	4,876	1,814	2
1/4	1,337	13,157	12,301	11,445	0,4	15,5	7,353	2,674	3
3/8	1,337	16,662	15,806	14,950	0,4	19	7,687	2,674	3,2
1/2	1,814	20,955	19,793	18,631	0,5	23,5	9,979	3,628	4,1
3/4	1,814	26,441	25,279	24,117	0,5	29	11,339	3,628	4,6
1	2,309	33,249	31,770	30,291	0,6	36	12,700	4,618	5,3
1 1/4	2,309	41,910	40,431	38,952	0,6	44,5	15,009	4,618	6,4
1 1/2	2,309	47,803	46,324	44,845	0,6	50,5	15,009	4,618	6,4
2	2,309	59,614	58,135	56,656	0,6	62	18,184	4,618	8
2 1/2	2,309	75,184	73,705	72,226	0,6	77,5	20,926	6,927	9,2
3	2,309	87,884	86,405	84,926	0,6	90,5	24,101	6,927	10,4
4	2,309	113,030	111,551	110,072	0,6	115,5	28,864	6,927	12,8
5	2,309	138,430	136,951	135,472	0,6	141	32,039	6,927	14,4
6	2,309	163,830	162,351	160,872	0,6	166,5	32,039	6,927	14,4

NOTE The values given in columns 3, 4 and 5 are basic values intended for the calculation of diameters at the gauge plane in accordance with 7.1.1.

5.4 Taper plain ring gauge (gauge No. 4)

This gauge is a 1:16 taper plain ring gauge (see Figure 5) and is suitable for checking the major diameter (d) and the related useful thread length on taper external (R) threads.

The dimensions of this gauge are given in Table 5 and manufacturing tolerances are given in 7.1.2.

The gauge incorporates a step equal in length to the total tolerance (T_1) on gauge length, specified in ISO 7-1. The step is situated between minimum and maximum gauge lengths measured from the gauge plane.

The overall length (l_9) of the gauge corresponds to the length of useful thread for maximum gauge length.

The small diameter end face of the gauge is marked '+' (positive) and the face of the tolerance step is marked '-' (negative).

NOTE These signs indicate the maximum and minimum gauge lengths, respectively the corresponding minimum and maximum allowable major diameters of the external thread.

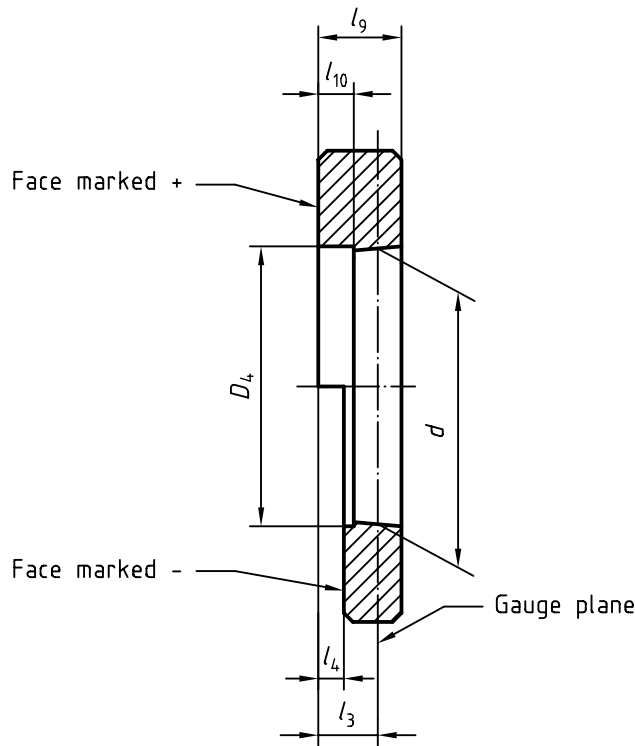

Figure 5 — Taper plain ring gauge (gauge No. 4)

Table 5 — Dimensions of taper plain ring gauge (gauge No. 4)

Dimensions in millimetres

Designation of thread	Diameter at gauge plane	Diameter of counterbore	Length from gauge plane to small end of gauge	Length of tolerance step	Overall length of gauge	Depth of counterbore
	d	D_4	l_3	l_4	l_9	l_{10}
1	2	3	4	5	6	7
1/16	7,723	9,5	4,876	1,814	7,369	2,3
1/8	9,728	11,5	4,876	1,814	7,369	2,3
1/4	13,157	15,5	7,353	2,674	11,030	3,3
3/8	16,662	19	7,687	2,674	11,364	3,3
1/2	20,955	23,5	9,979	3,628	14,965	4,5
3/4	26,441	29	11,339	3,628	16,326	4,5
1	33,249	36	12,700	4,618	19,049	5,8
1 1/4	41,910	44,5	15,009	4,618	21,358	5,8
1 1/2	47,803	50,5	15,009	4,618	21,358	5,8
2	59,614	62	18,184	4,618	25,688	5,8
2 1/2	75,184	77,5	20,926	6,927	30,161	8,1
3	87,884	90,5	24,101	6,927	33,336	8,1
4	113,030	115,5	28,864	6,927	39,253	8,1
5	138,430	141	32,039	6,927	43,582	8,1
6	163,830	166,5	32,039	6,927	43,582	8,1

NOTE The values given in column 2 are basic values intended for the calculation of diameters at the gauge plane in accordance with 7.1.2.

5.5 Taper modified thread form check plug gauge (gauge No. 5)

This check plug gauge (see Figure 6) is used to check the dimensions of the parallel threaded ring gauge (gauge No. 3) when manufacturing the ring gauge and for checking the ring gauge for wear.

The gauge is designed on the basis of the taper threaded plug gauge (gauge No. 1). The tolerance step has been retained, but with respect to the gauge plane it is positioned entirely in the plus tolerance zone.

The threads of the check plug gauge are truncated at the crests and provided with a clearance groove at the root of the thread in order to ensure the pitch diameters engage when gauging is carried out.

The dimensions of this check plug gauge are given in Table 6.

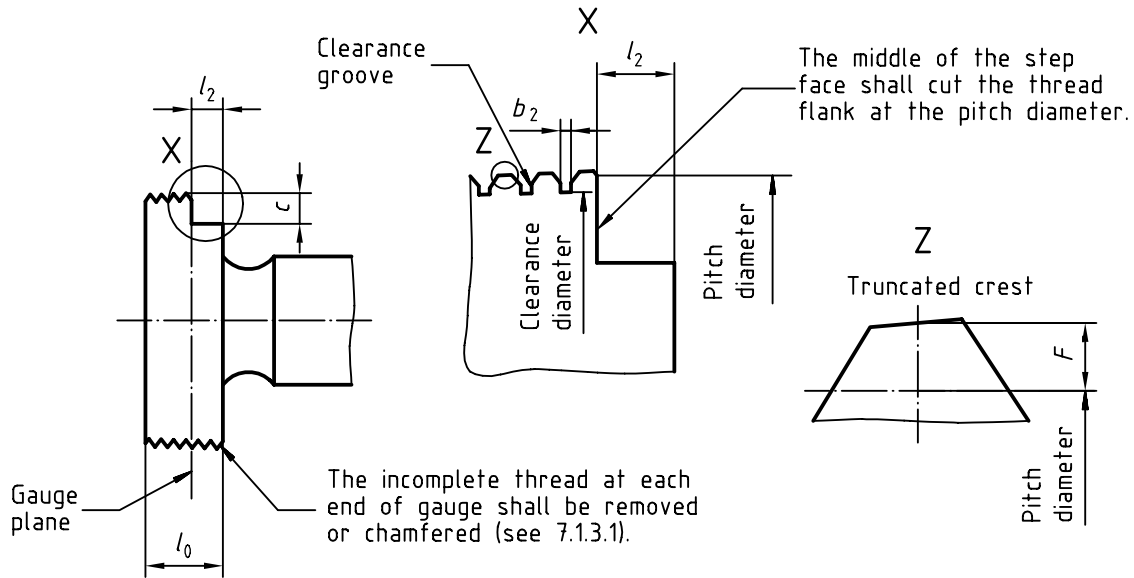

Figure 6 — Taper modified thread form check plug gauge (gauge No. 5)

Table 6 — Dimensions of taper modified thread form check plug gauge (gauge No. 5)

Dimensions in millimetres

Designation of thread	Pitch <i>P</i>	Diameters at gauge plane			Width of clearance groove <i>b₂</i>	Height of step <i>c</i>	Overall length of gauge <i>l₀</i>	Length of tolerance step <i>l₂</i>	Radial distance from pitch diameter to truncated crest <i>F</i>
		major <i>d, D</i>	pitch <i>d₂, D₂</i>	minor <i>d₁, D₁</i>					
1	2	3	4	5	6	7	8	9	10
1/16	0,907	7,723	7,142	6,561	0,3	1,8	5,6	2,268	0,145
1/8	0,907	9,728	9,147	8,566	0,3	1,8	5,6	2,268	0,145
1/4	1,337	13,157	12,301	11,445	0,4	2,4	8,4	3,342	0,214
3/8	1,337	16,662	15,806	14,950	0,4	2,4	8,8	3,342	0,214
1/2	1,814	20,955	19,793	18,631	0,5	3,3	11,4	4,536	0,290
3/4	1,814	26,441	25,279	24,117	0,5	4,5	12,7	4,536	0,290
1	2,309	33,249	31,770	30,291	0,8	5,8	14,5	5,773	0,369
1 1/4	2,309	41,910	40,431	38,952	0,8	5,8	14,5	5,773	0,369
1 1/2	2,309	47,803	46,324	44,845	0,8	5,8	14,5	5,773	0,369
2	2,309	59,614	58,135	56,656	0,8	5,8	15	5,773	0,369
2 1/2	2,309	75,184	73,705	72,226	0,8	6,9	17,5	6,927	0,369
3	2,309	87,884	86,405	84,926	0,8	6,9	18,5	6,927	0,369
4	2,309	113,030	111,551	110,072	0,8	6,9	20	6,927	0,369
5	2,309	138,430	136,951	135,472	0,8	10	24	6,927	0,369
6	2,309	163,830	162,351	160,872	0,8	10	24	6,927	0,369

NOTE The values given in columns 3, 4 and 5 are basic values intended for the calculation of diameters at the gauge plane in accordance with 7.1.3.

5.6 Parallel modified thread form check ring gauge (gauge No. 6)

This check ring gauge (see Figure 7) is provided to check the dimensions of the taper full form threaded plug gauges (gauge Nos. 1 and 2) when manufacturing the plug gauges and for checking the plug gauges for wear.

NOTE The use of gauge No. 6 when manufacturing gauge Nos. 1 and 2 is at the discretion of the gauge manufacturer. The use of gauge No. 6 for checking gauge Nos. 1 and 2 for wear is at the discretion of the gauge user.

The gauge is designed on the basis of the parallel full form threaded ring gauge (gauge No. 3) except that there is no tolerance step.

The threads of the check ring gauge are truncated at the crests and provided with a clearance groove at the root of the thread to ensure the pitch diameters engage when gauging is carried out.

The dimensions of the check ring gauge are given in Table 7.

One face of the gauge is marked to indicate the position of the gauge plane. This marking shall be "Gauge plane" or some other words or symbols agreed between the gauge manufacturer and the purchaser.

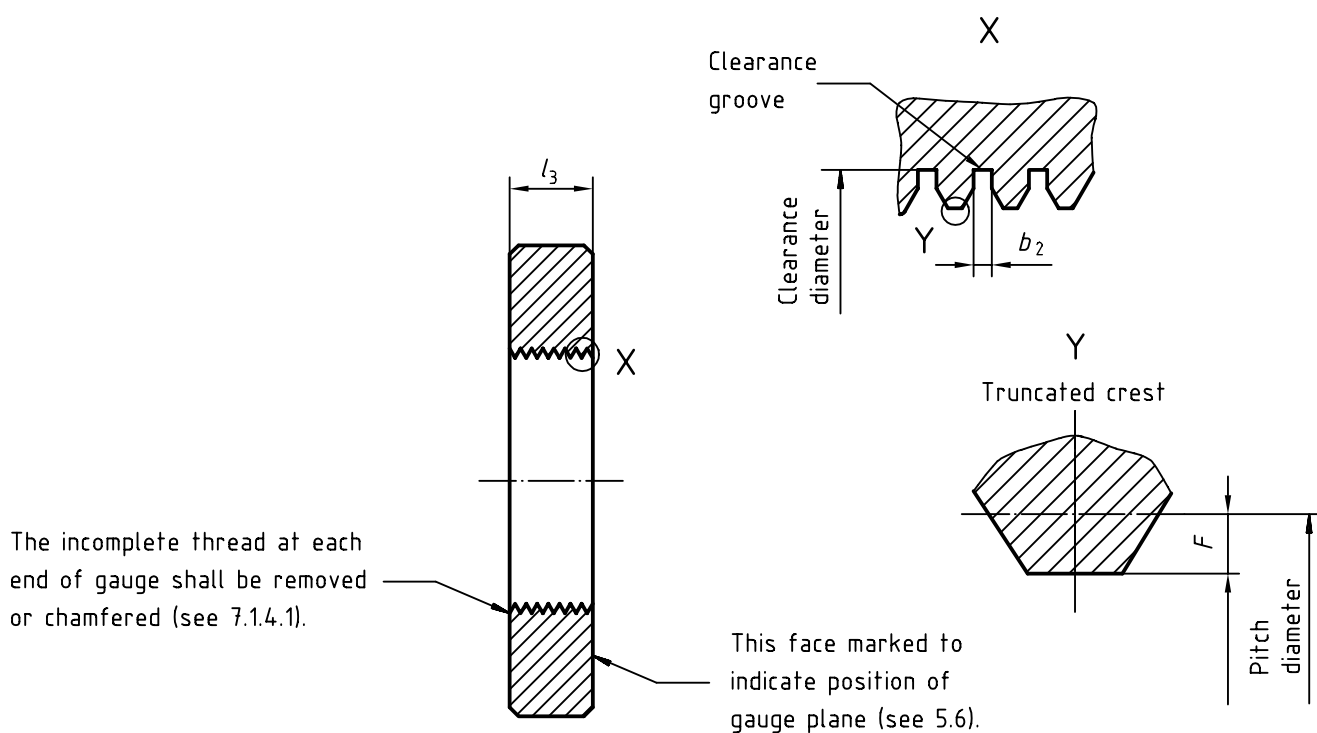

Figure 7 — Parallel modified thread form check ring gauge (gauge No. 6)

Table 7 — Dimensions of parallel modified thread form check ring gauge (gauge No. 6)

Dimensions in millimetres

Designation of thread	Pitch P	Diameters at gauge plane			Width of clearance groove b_2	Overall length of gauge l_3	Radial distance from pitch diameter to truncated crest F
		major d, D	pitch d_2, D_2	minor d_1, D_1			
1	2	3	4	5	6	7	8
1/16	0,907	7,723	7,142	6,561	0,3	4,8	0,145
1/8	0,907	9,728	9,147	8,566	0,3	4,8	0,145
1/4	1,337	13,157	12,301	11,445	0,4	7,3	0,214
3/8	1,337	16,662	15,806	14,950	0,4	7,6	0,214
1/2	1,814	20,955	19,793	18,631	0,5	9,9	0,290
3/4	1,814	26,441	25,279	24,117	0,5	11,3	0,290
1	2,309	33,249	31,770	30,291	0,8	12,7	0,369
1 1/4	2,309	41,910	40,431	38,952	0,8	15	0,369
1 1/2	2,309	47,803	46,324	44,845	0,8	15	0,369
2	2,309	59,614	58,135	56,656	0,8	18,1	0,369
2 1/2	2,309	75,184	73,705	72,226	0,8	20,9	0,369
3	2,309	87,884	86,405	84,926	0,8	24,1	0,369
4	2,309	113,030	111,551	110,072	0,8	28,8	0,369
5	2,309	138,430	136,951	135,472	0,8	32	0,369
6	2,309	163,830	162,351	160,872	0,8	32	0,369

NOTE The values given in columns 3, 4 and 5 are basic values intended for the calculation of diameters at the gauge plane in accordance with 7.1.4.

6 Use of gauges and checking of pipe threads

6.1 General

The gauging system described provides methods by which the requirements specified in ISO 7-1 can be controlled and checked, when used in conjunction with other means (not defined in this part of ISO 7) of controlling and checking the correctness of other thread elements.

NOTE Failure to control those thread elements which require checking by other means could adversely affect the gauging results obtained with this system.

It is intended that the full range of appropriate gauges is used when inspecting the threaded workpiece. The full range of gauges is shown in annex A. In the event of a dispute, the acceptance or rejection of the workpiece shall be based on the use of all appropriate gauges.

The gauging system described is equally applicable to parallel and taper internally threaded workpieces.

6.2 Checking of internal taper (Rc) and internal parallel (Rp) threads

When a check of both diameter and accommodation length of the internal threads on the workpiece is required, the gauging procedure in this clause should be applied. The use of gauge No. 2 may be omitted when the design of the workpiece ensures adequate accommodation length is available, but it should be noted that malformed threads may not be detected if gauge No. 2 is not used.

The internal thread meets the requirements of ISO 7-1 if each stage of inspection is satisfactory and the position of the gauge step relative to the end face of the threaded workpiece is the same at each stage within a total range of readings of $0,5P$.

NOTE 1 A variation in the relative position of the gauge steps of gauge Nos. 1 and 2 in excess of $0,5P$ but not greater than $1P$ is permissible when the manufacturer and purchaser agree that the use of a thread sealant during assembly of the workpiece will compensate for the increased difference in the gauging results.

NOTE 2 In the case of Rp threads, if the depth of chamfer at the pitch diameter of the threads is more or less than $0,5P$, then the gauging result will be slightly affected.

Stage 1: The taper threaded plug gauge (gauge No. 1) is screwed hand tight into the internal thread. The internal thread is within the permissible tolerance if the end face of the threaded workpiece lies between the step faces, or flush with one of the step faces on the gauge (see Figure 8).

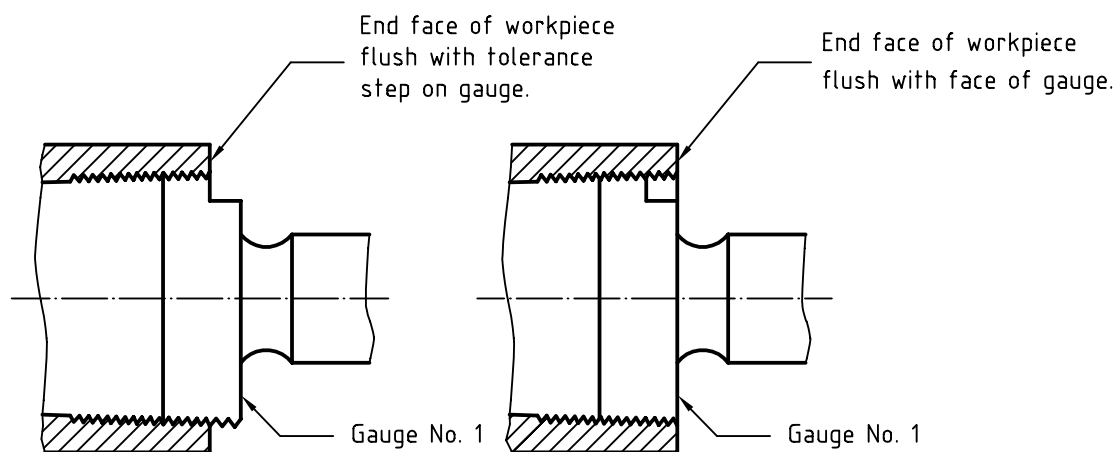

Figure 8 — Checking of internal taper (Rc) and parallel (Rp) threads — Stage 1

Stage 2: The taper threaded plug gauge with relief (gauge No. 2) is screwed hand tight into the internal thread. The internal thread is within the permissible tolerances if the end face of the threaded workpiece lies between the step faces, or flush with one of the step faces on the gauge (see Figure 9).

NOTE 3 If a workpiece is rejected by gauge No. 2 but accepted by gauge No. 1, then this may indicate a lack of accommodation length.

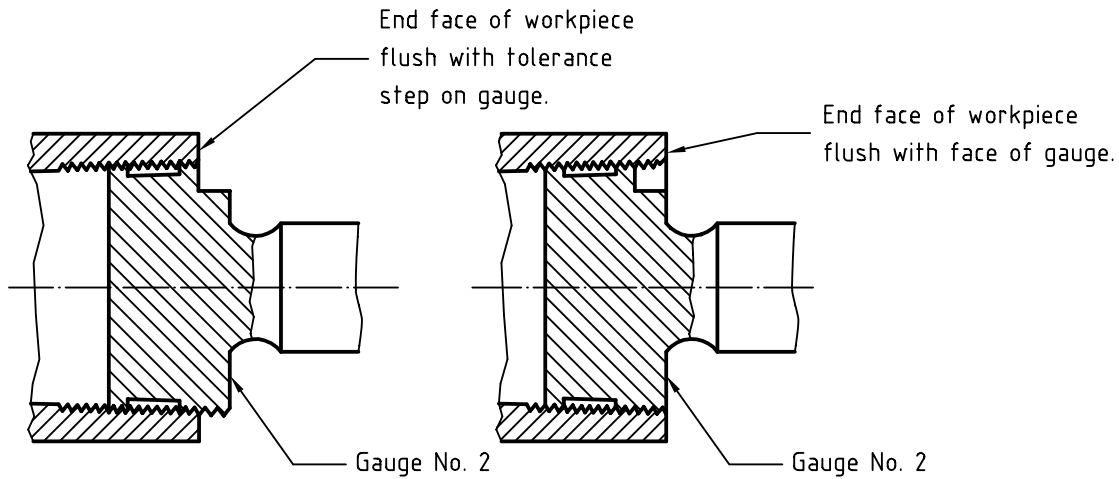

Figure 9 — Checking of internal taper (Rc) and parallel (Rp) threads — Stage 2

6.3 Checking of external taper (R) threads

When a complete check of the external threads on the workpiece is required, the gauging procedure in this clause should be applied.

The external thread meets the requirement of ISO 7-1 if each stage of inspection is satisfactory and the position of the gauge step relative to the end face of the threaded workpiece is the same at each stage within a total range of readings of $0,5P$.

NOTE A variation in the relative positions of the gauge steps of gauge Nos. 3 and 4 in excess of $0,5P$ but not greater than $1P$ is permissible when the manufacturer and purchaser agree that the use of a thread sealant during the assembly of the workpiece will compensate for the increased difference in the gauging results.

Stage 1: The threaded ring gauge (gauge No. 3) is screwed hand-tight onto the external thread. The external thread is within the permissible tolerances if the end face of the workpiece lies between the step faces, or flush with one of the step faces on the gauge (see Figure 10).

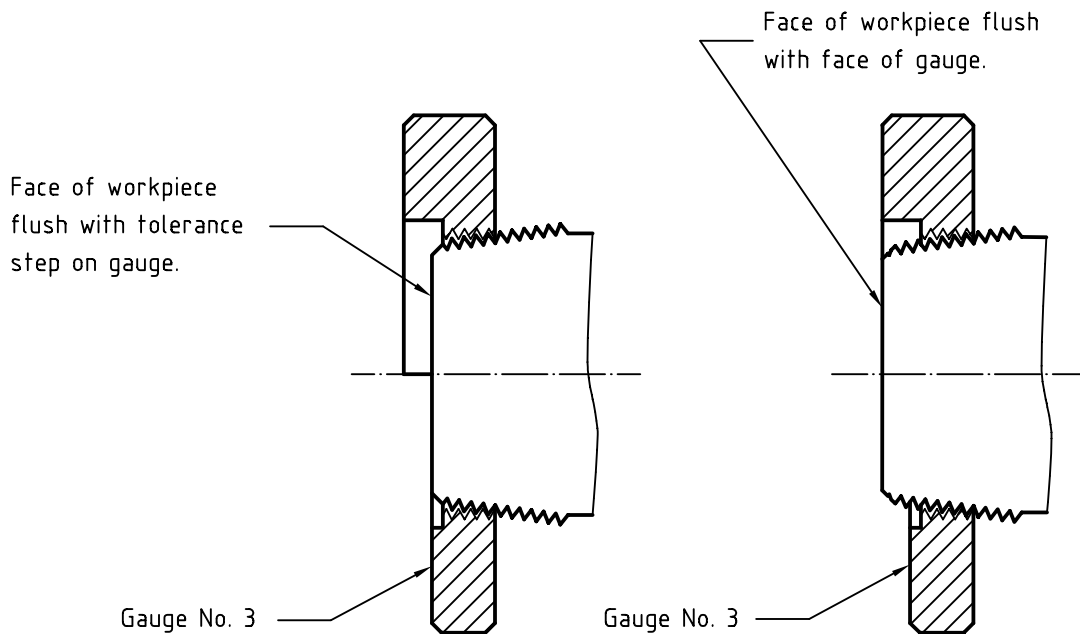

Figure 10 — Checking of external threads (R) — Stage 1

Stage 2: The taper plain ring gauge (gauge No. 4) is positioned hand tight over the external thread. The external thread is within the permissible tolerances if the end face of the threaded workpiece lies between the step faces, or flush with one of the step faces on the gauge (see Figure 11) and the roots of all threads within the area covered by the gauge are fully formed.

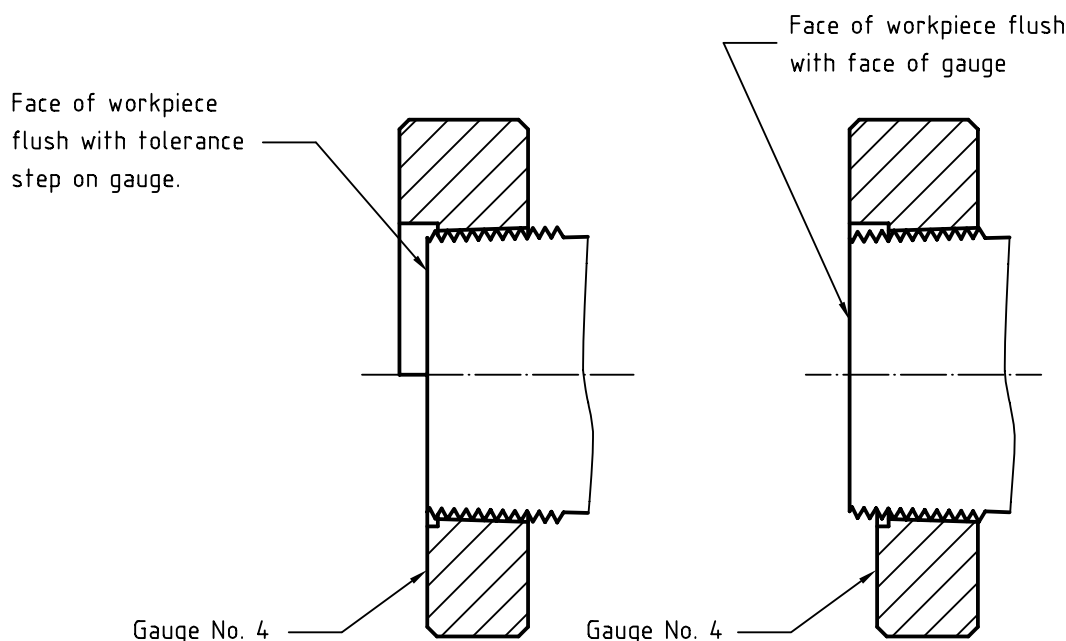

Figure 11 — Checking of external threads (R) — Stage 2

7 Gauge dimensions and manufacturing tolerances, checking of new gauges and checking gauges for wear

7.1 Gauge dimensions and manufacturing tolerances

7.1.1 Taper full form threaded plug gauges and parallel full form threaded ring gauges

7.1.1.1 Gauge dimensions

Dimensions of gauges shall be as given in 5.2 and 5.3 and tables 2 to 4, except that thread diameters of new plug gauges are enlarged by an amount T_{PL} and new ring gauges are reduced by an amount T_R from the basic diameters at the plane gauge so as to provide a wear allowance (see Table 9).

The root of the threads shall be either:

- a) full form with a radius equal to $0,137\ 329P$, or
- b) modified form with a clearance groove or a sharp form with a root radius less than $0,137\ 329P$. The clearance groove may be displaced relative to the centreline of the thread profile within the limits shown in Figure 12.

Incomplete threads, including threads which have been chamfered, may be damaged in use. The incomplete threads at each end of the gauge, and in the case of gauge No. 2 also at each end of the thread relief, shall therefore be removed or a chamfer provided as shown in Figures 13 a) and 13 b). The removal of incomplete threads is the preferred method. The amount of incomplete thread removal shall be between $0,5P$ and $1P$. On gauge No. 2 a minimum of one full thread must be retained between the relief and the tolerance step.

Formulae for the calculation of thread diameters of plug gauges and ring gauges are given in Table 8.

Formulae for the calculation of thread diameters of ring gauges in Table 8 exclude the pitch diameter because pitch diameters will be controlled by the taper modified thread form check plug gauge.

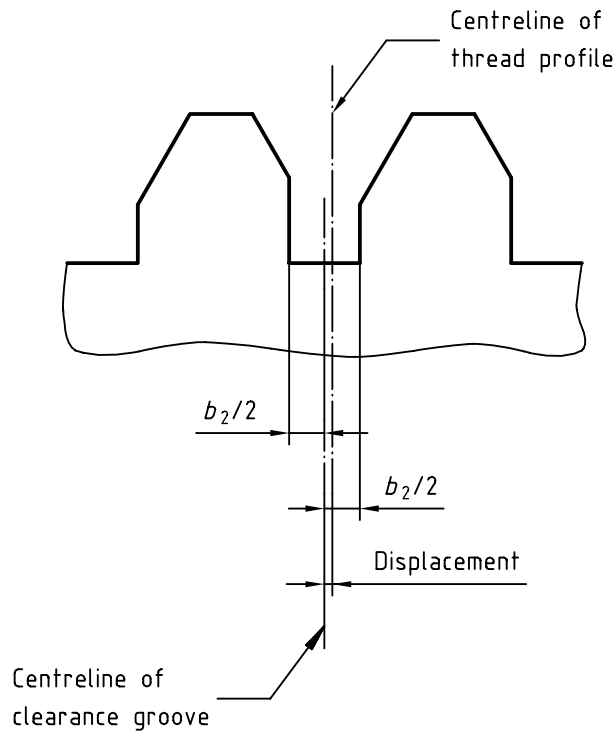

Dimensions in millimetres

Designation of thread	Displacement max.
1/16 to 3/8	0,04
1/2 to 6	0,05

Figure 12 — Permitted displacement of clearance groove

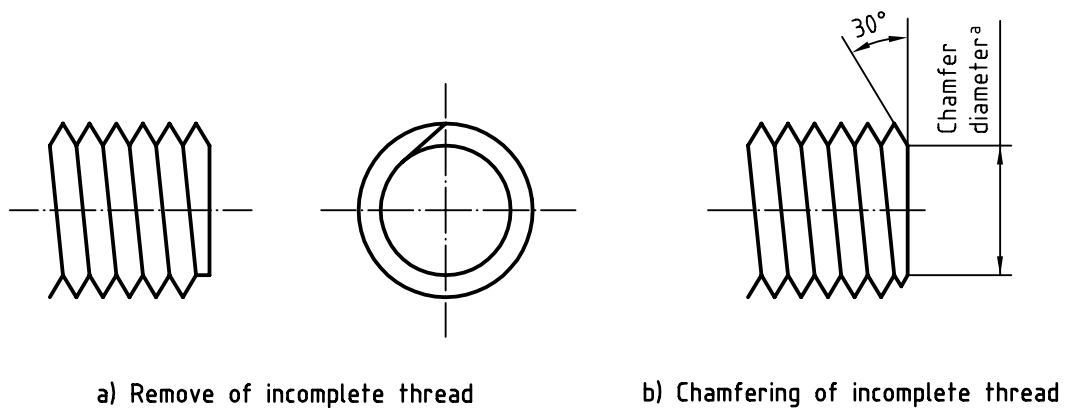

a) Remove of incomplete thread

b) Chamfering of incomplete thread

NOTE 1 Figure a) shows one complete thread removed.

NOTE 2 Figures a) and b) show external threads, equivalent requirements apply to internal threads.

^a At minor diameter (external threads) or major diameter (internal threads).

Figure 13 — Removal and chamfering of incomplete threads

7.1.1.2 Manufacturing tolerances and wear allowances

The tolerances for manufacturing are:

- tolerance on thread diameters and wear allowance: the tolerances on thread diameters and wear allowance are given in Table 9;
- tolerance on lengths: the tolerances on lengths are given in Table 10,
- tolerance on pitch: the tolerances on pitch are given in Table 11. The tolerance on the pitch applies to any number of threads situated within the threaded length of the gauge, but excludes the first full form thread at each end of the gauge;
- tolerance on flank angle: the tolerances on the flank angle of $27,5^\circ$ are given in Table 12;
- tolerance on taper: the tolerances on the taper of the full form threaded plug gauges measured on diameter are

$$(5 + l) \mu\text{m}$$

where l is the overall length (in millimetres) of the relevant gauge but excluding the first full thread at each end of the gauge.

EXAMPLE The tolerance on the diameter of a size 2 taper full form threaded plug gauge is $(5 + l_0) \mu\text{m} = (5 + 15) \mu\text{m} = 20 \mu\text{m}$.

NOTE The tolerance on taper is applied such that the tolerance will tend to increase the taper, that is the taper angle will become larger.

Table 8 — Formulae for the calculation of diameters at the gauge plane for gauge Nos. 1, 2 and 3

Diameter	Taper full form threaded plug gauges	Parallel full form threaded ring gauges
Major diameter (plug gauges) or clearance diameter (ring gauges)	$(D + T_{PL}) \pm T_{PL}$	$> d$
Pitch diameter	$(D_2 + T_{PL}) \pm 0,5 T_{PL}$	see 7.1.1.1
Minor diameter (ring gauges) or clearance diameter (plug gauges)	$< D_1$	$(d_1 - T_R) \pm T_R$

Table 9 — Diametral tolerances and wear allowances for gauge Nos. 1, 2, 3 and 4

Tolerances in micrometres

Designation of thread	T_R	T_{PL}
1/16 and 1/8	12	8
1/4 and 3/8	14	8
1/2 and 3/4	14	10
1 to 2	18	12
2 1/2 to 6	24	16

Table 10 — Tolerances on lengths

Tolerances in millimetres

Designation of thread	Tolerances on lengths			
	Dimensions			
	l_0, l_6, l_9	l_1, l_2, l_4	l_3	b_2
1/16 to 3/8	+ 0,013 0	± 0,013	0 - 0,013	± 0,04
1/2 and 3/4	+ 0,013 0	± 0,013	0 - 0,013	± 0,05
1	+ 0,013 0	± 0,025	0 - 0,025	± 0,05
1 1/4 to 6	+ 0,025 0	± 0,025	0 - 0,025	± 0,05

Table 11 — Tolerances on pitch

Tolerances in micrometres

Designation of thread	Tolerance on pitch T_P
1/16 to 3/4	8
1 to 2	10
2 1/2 to 6	12

Table 12 — Tolerances on flank angle

Tolerances in minutes

Designation of thread	Tolerance on flank angle	
	$T_{\alpha 1}/2$	$T_{\alpha 2}/2$
	Full form threads	Modified form threads
1/16 and 1/8	± 15	± 16
1/4 and 3/8	± 13	± 16
1/2 and 3/4	± 11	± 14
1 to 6	± 10	± 14

7.1.2 Taper plain ring gauges

7.1.2.1 Gauge dimensions

Dimensions of gauges shall be as given in 5.4 and Table 5, except that the diameters of new ring gauges are reduced by an amount T_R from the diameters at the gauge plane to provide a wear allowance (see Table 9).

Plain ring gauge:

$$\text{Diameter at gauge plane} = (d - T_R) \pm 0,75 T_R$$

7.1.2.2 Manufacturing tolerances and wear allowances

The tolerances for manufacturing are:

- tolerance on diameters and wear allowances: the tolerances on diameters and wear allowances are given in Table 9;
- tolerance on lengths: the tolerances on lengths are given in Table 10;
- tolerance on taper: The tolerances on the taper of the plain ring gauges measured on diameter is $(10 + l) \mu\text{m}$, where l is the overall length (in millimetres) of the relevant gauge.

NOTE 1 On the plain ring gauge the overall length will exclude the counterbore at the small end.

NOTE 2 The tolerance on taper is applied such that the tolerance will tend to reduce the taper, that is the taper angle will become smaller.

7.1.3 Taper modified thread form check plug gauges

7.1.3.1 Gauge dimensions

Dimensions of gauges shall be as given in 5.5 and Table 6, except that the thread diameters shall be reduced by an amount T_R from the basic diameters at the gauge plane to align with the same reduction in the full form threaded ring gauge dimensions. A further reduction shall be applied to the major diameter in the form of a truncation and to the minor diameter in the form of a clearance groove to ensure clearance at the crest and root in use.

The clearance groove may be omitted provided that the radius at the root of the thread is reduced such as to ensure there will be no interference with the crests of the threads on the parallel full form threaded ring gauges in use.

The incomplete threads at each end of the gauge shall be removed or a chamfer provided as shown in Figure 13. The amount of incomplete thread removed shall be between $0,5P$ and $1P$. The removal of incomplete threads is the preferred method.

Formulae for the calculation of thread diameters at the gauge plane are given in Table 13.

Table 13 — Formulae for calculation of diameters at the gauge plane for gauge No. 5

Diameter	Formula
Major diameter	$(d_2 - T_R + 2 F) \pm T_{CP}$
Pitch diameter	$(d_2 - T_R) \pm 0,5 T_{CP}$
Clearance diameter	$< (d_1 - T_R - 0,75 T_R)$

7.1.3.2 Manufacturing tolerances

The tolerances for manufacturing are:

- a) tolerances on thread diameters: the tolerances on thread diameters are given in Table 14;
- b) tolerances on lengths: the tolerances on lengths are given in Table 10;
- c) tolerances on pitch: the tolerances on pitch are given in Table 11;
- d) tolerances on flank angle: the tolerances on the flank angle of 27,5° are given in Table 12;
- e) tolerances on taper: the tolerances on taper shall be as given in 7.1.1.2 e).

Table 14 — Tolerances on thread diameter for gauge Nos. 5 and 6
Tolerances in micrometres

Designation of thread	T_{CP}
1/16 and 1/8	8
1/4 and 3/8	8
1/2 and 3/4	8
1 to 2	10
2 1/2 to 6	12

7.1.4 Parallel modified thread form check ring gauge

7.1.4.1 Gauge dimensions

Dimensions of gauges shall be as given in 5.6 and Table 7, except that the pitch diameters are adjusted such as to allow the pitch diameter to be verified with the taper modified thread form check plug gauge. The major and minor diameters are adjusted by a clearance groove and by truncation respectively to ensure clearance at the root and crest in use.

The clearance groove may be omitted provided that the radius at the root of the thread is reduced such as to ensure there will be no interference with the crests of the threads on the taper full form threaded plug gauges in use.

The incomplete threads at each end of the gauge shall be removed or a chamfer provided as shown in Figure 13. The amount of incomplete thread removed shall be between $0,5P$ and $1P$.

Formulae for the calculation of the major and minor thread diameters are given in Table 15. A formula for the calculation of pitch diameter is not given because the pitch diameter will be controlled by the taper modified thread form check plug gauge.

Table 15 — Formulae for the calculation of diameters at the gauge plane for gauge No. 6

Diameter	Formula
Clearance diameter	$> (d + 2 T_{PL})$
Pitch diameter	See 7.1.4.1
Minor diameter	$(D_2 - 2 F) \pm T_{PL}$

7.1.4.2 Manufacturing tolerances

The tolerances for manufacturing are:

- tolerances on thread diameters: the tolerances on thread diameters are given in Table 14;
- tolerances on lengths: the tolerances on lengths are given in Table 10;
- tolerances on pitch: the tolerances on pitch are given in Table 11;
- tolerances on flank angle: the tolerances on the flank angle of $27,5^\circ$ are given in Table 12.

7.2 Checking of new gauges

7.2.1 Checking of new taper full form threaded plug gauges

These shall be checked by direct measurement and shall conform to the dimensions and tolerances specified in 7.1.1.1. and 7.1.1.2 except that the pitch diameter may be checked with the parallel modified thread form check ring gauge at the discretion of the manufacturer unless specified otherwise by the purchaser. The face of the step of the taper full form threaded plug gauge shall be within the limits shown in Figure 14 relative to that face of the parallel modified thread form check ring gauge which is marked to indicate the position of the gauge plane.

NOTE In the event of a dispute regarding the pitch diameter of the taper full form threaded plug gauges, results obtained by direct measurement take precedence over results obtained from the use of the parallel modified thread form check ring gauge.

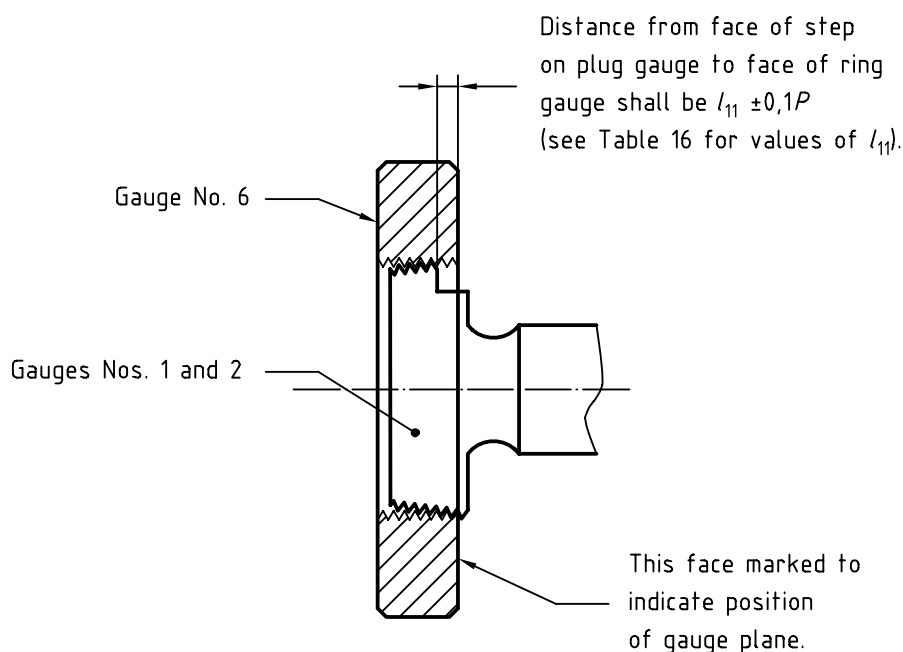

Figure 14 — Checking of pitch diameter of new taper full form threaded plug gauges using parallel modified thread check ring gauge

7.2.2 Checking of new parallel full form threaded ring gauges

The pitch diameter shall be checked with the taper modified thread form check plug gauge. Other dimensions shall be checked by direct measurement, and shall conform to the dimensions and tolerances given in 7.1.1.1. and 7.1.1.2.

The face of the step of the taper modified thread form check plug gauge shall lie within $\pm 0,1P$ of the face of the parallel full form threaded ring gauge at the face opposite to the step as shown in Figure 15.

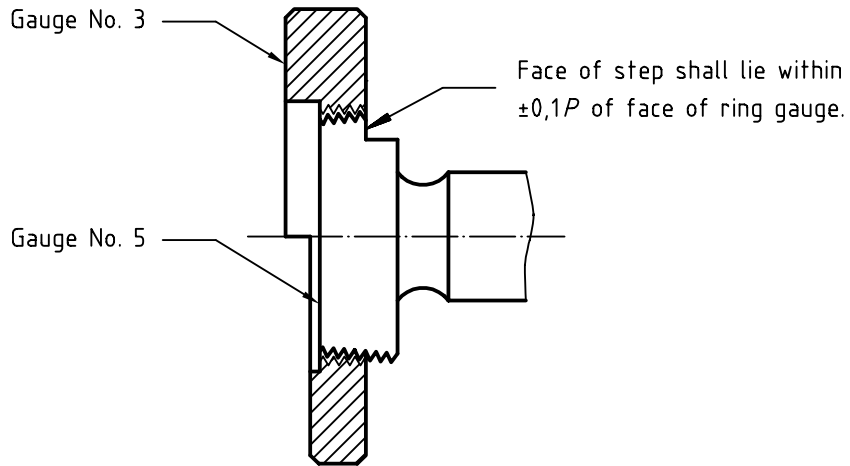

Figure 15 — Checking of pitch diameter of new parallel full form threaded ring gauges using taper modified thread form check plug gauges

Table 16 — Values of l_{11} , l_{12} , l_{13} and l_{14}

Dimensions in millimetres

Designation of thread	Dimensions			
	l_{11}	l_{12}	l_{13}	l_{14}
1/16	0,326	0,064	0,681	0,419
1/8	0,326	0,064	0,681	0,419
1/4	0,680	0,064	1,142	0,558
3/8	0,680	0,064	1,142	0,558
1/2	1,009	0,064	1,622	0,677
3/4	1,009	0,064	1,622	0,677
1	1,265	0,080	2,035	0,865
1 1/4	1,265	0,080	2,035	0,865
1 1/2	1,265	0,080	2,035	0,865
2	1,265	0,080	2,035	0,865
2 1/2	1,705	0,096	2,539	0,961
3	1,705	0,096	2,539	0,961
4	1,705	0,096	2,539	0,961
5	1,705	0,096	2,539	0,961
6	1,705	0,096	2,539	0,961

NOTE The values given in Table 16 have been calculated as follows:

$$l_{11} = 0,5T_2 - 0,5P - \frac{(T_{PL} + T_R)}{0,0625 \times 10^3} \text{ mm}$$

$$l_{12} = \frac{T_{CP}}{2 \times 0,0625 \times 10^3} \text{ mm}$$

$$l_{13} = 0,5T_2 - 0,5P - \frac{T_R}{0,0625 \times 10^3} + 0,25P \text{ mm}$$

$$l_{14} = \frac{T_R}{0,0625 \times 10^3} + 0,25P \text{ mm}$$

where T_2 and P are expressed in millimetres;

T_{PL} , T_R and T_{CP} are expressed in micrometres.

7.2.3 Checking of new plain taper ring gauges

These shall be checked by direct measurement and shall conform to the dimensions and tolerances specified in 7.1.2.1 and 7.1.2.2

7.2.4 Checking of new taper modified thread form check plug gauges

These shall be checked by direct measurement and shall conform to the dimensions and tolerances specified in 7.1.3.1 and 7.1.3.2.

7.2.5 Checking of new parallel modified thread form check ring gauges

The pitch diameter shall be checked with the taper modified thread form check plug gauge. Other dimensions shall be checked by direct measurement and shall conform to the dimensions and tolerances specified in 7.1.4.1 and 7.1.4.2. The face of the step of the taper modified thread form check plug gauge shall lie within the limits shown in Figure 16 relative to that face of the parallel modified thread form check ring gauge which is marked to indicate the position of the gauge plane.

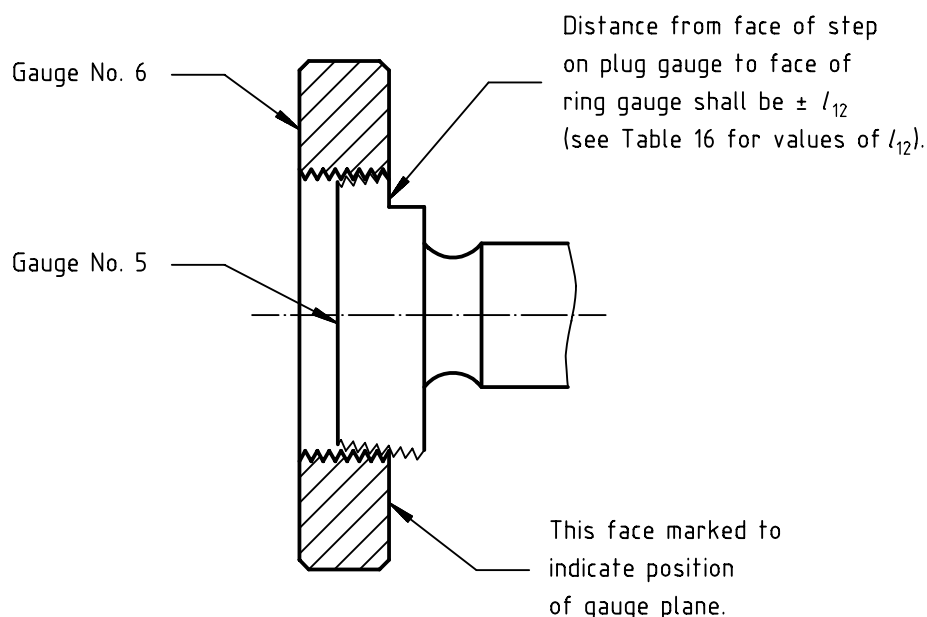

Figure 16 — Checking of pitch diameter of new parallel modified thread form ring gauges using taper modified thread form check plug gauge

7.3 Checking gauges for wear

7.3.1 Permissible wear on diameters

The permissible wear on the basic diameters at the gauge plane on full form threaded plug and ring gauges shall be as specified in Table 17. The values of *W* correspond to the change in diameter over a length of $0,25P$ of a taper thread. The values are negative (-) for plug gauges and positive (+) for ring gauges.

Table 17 — Permissible wear

Tolerances in micrometres

Designation of thread	Permissible wear <i>W</i>
1/16 and 1/8	14
1/4 and 3/8	21
1/2 and 3/4	28
1 to 6	36

The taper modified thread form check plug gauge shall be within the tolerances specified in 7.1.3.1 and the parallel modified thread form check ring gauge shall be within the tolerances specified in 7.1.4.1.

7.3.2 Checking of gauges for wear

The full form threaded plug and ring gauges and plain ring gauges shall be checked for wear periodically, taking into account the conditions of use.

The pitch diameter of taper threaded plug gauges may, at the discretion of the manufacturer, unless otherwise specified by the purchaser, be checked with the parallel modified thread form check ring gauge. The major diameter of taper threaded plug gauges shall be checked by direct measurement. Gauges shall be discarded when the major diameter and/or pitch diameter falls below the basic major diameter and/or pitch diameter by the amount *W* specified in Table 17, when checked by direct measurement. Gauges shall also be discarded when the face of the step of the taper full form threaded plug gauges relative to that face of the parallel modified thread form check ring gauge which is marked to indicate the position of the gauge plane, exceeds the limit shown in Figure 17, when checked by this method.

NOTE In the event of a dispute regarding the pitch diameter of the taper full form threaded plug gauges, results obtained by direct measurement take precedence over results obtained from the use of the parallel modified thread form check ring gauges.

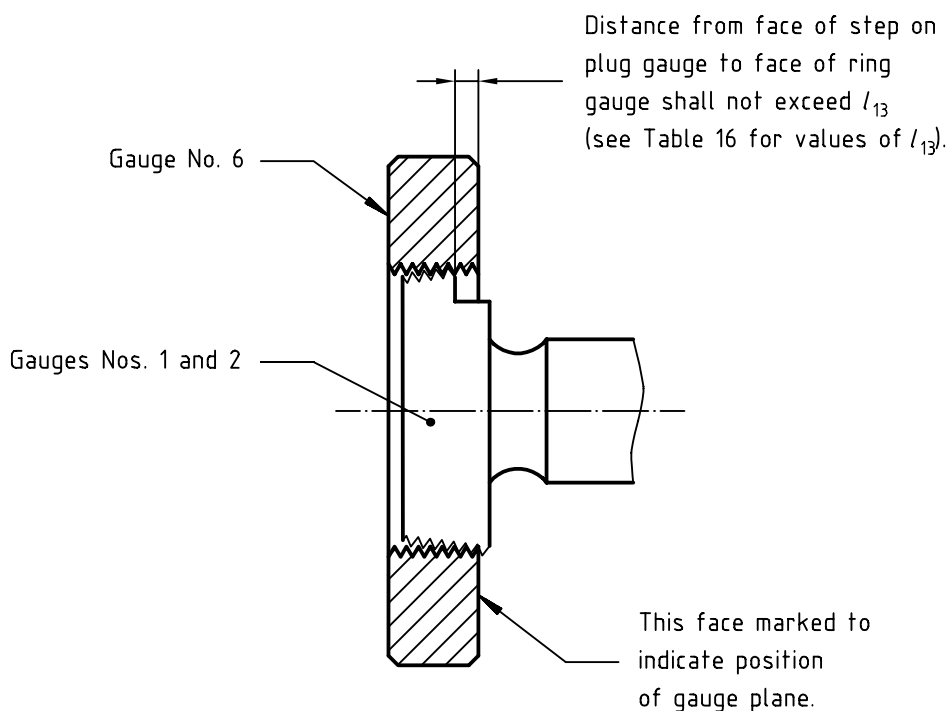

Figure 17 — Checking pitch diameter of taper full form threaded plug gauges for wear using parallel modified thread form check ring gauge

Parallel full form threaded ring gauges shall be checked by using the taper modified thread form check plug gauges at the pitch diameter. The minor diameter shall be checked by direct measurement.

If the check plug gauge step enters the end of the ring gauge opposite to the step by an amount which exceeds the limit shown in Figure 18 and/or the wear on the minor diameter of the first full thread at the end of the ring gauge opposite to the step exceeds the basic minor diameter by the amount W specified in Table 17, the ring gauge shall be discarded.

Taper plain ring gauges shall be checked by direct measurement. Local wear over a length of $1P$ or less at each end of the gauge is acceptable.

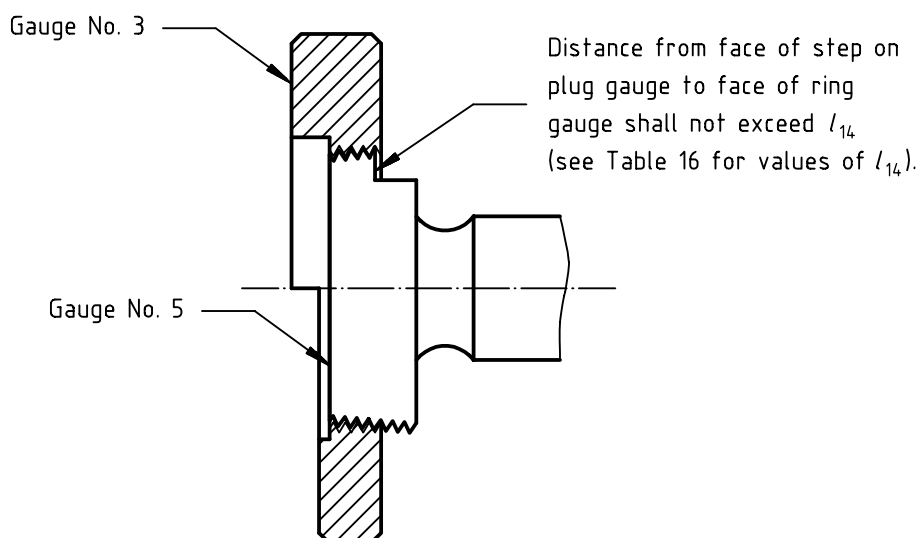

Figure 18 — Checking pitch diameter of parallel full form threaded ring gauge for wear using taper modified thread form plug gauge

7.4 Marking of gauges

7.4.1 All gauges

Gauges shall be marked with the following information:

- a) "ISO 7";
- b) thread size designation and symbol for thread being checked (see ISO 7-1:1994, 6.3);
- c) gauge number (see annex A);
- d) tolerance step markings (see 5.2 to 5.4) and gauge plane marking (see 5.6);
- e) gauge manufacturer's name or registered trademark or company logo;
- f) year of manufacture (last two digits) or number of series.

EXAMPLE 1 Threaded plug gauge: ISO 7 1 1/2 Rc /Rp No. 1 X & Co. 00

EXAMPLE 2 Threaded ring gauge: ISO 7 1 1/2 R No. 3 X & Co. 00

Annex A
(normative)

Summary of gauges

Gauge No. 1
Taper full form
threaded plug gauge

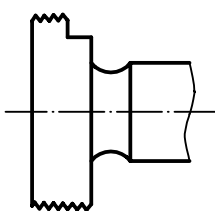

Gauge No. 2
Taper full form threaded
plug gauge with relief

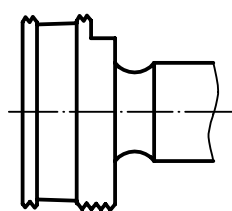

Gauge No. 3
Parallel full form
threaded ring gauge

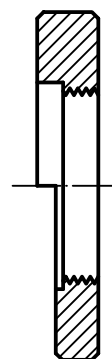

Gauge No. 4
Taper plain ring gauge

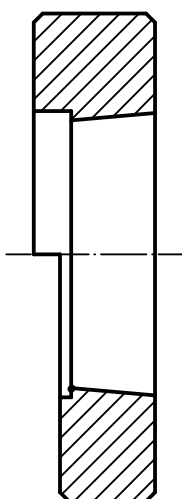

Gauge No. 5
Taper modified thread form
check plug gauge

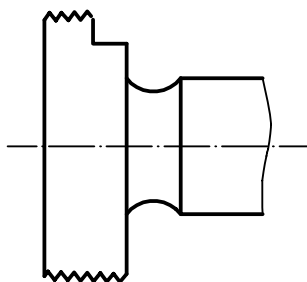

Gauge No. 6
Parallel modified thread form
check ring gauge

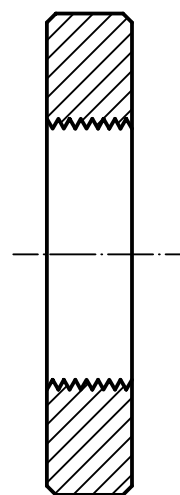

Figure A.1 — Summary of gauges, gauge numbers and thread elements controlled

Table A.1 — Internal threads: thread elements controlled and gauge numbers

Thread	Pitch diameter together with major diameter	Accommodation length
Taper, Rc	Gauge Nos. 1 and/or 2	Gauge No. 2
Parallel, Rp	Gauge Nos. 1 and/or 2	Gauge No. 2

Table A.2 — External threads: thread elements controlled and gauge numbers

Thread	Pitch diameter together with minor diameter	Useful thread length ^a	Major diameter
Taper, R	Gauge No. 3	Gauge No. 4	Gauge No. 4

^a The threads in the fitting allowance area should be checked visually or by other means to ensure the roots of the threads are fully formed.

ISO 7-2:2000(E)

ICS 21.040.30

Price based on 30 pages

© ISO 2000 – All rights reserved

Als Papierkopie - kein Änderungsdienst / Printed copy - no alert service