

INTERNATIONAL STANDARD

ISO
7-1

Third edition
1994-05-15

Pipe threads where pressure-tight joints are made on the threads —

Part 1: Dimensions, tolerances and designation

*Filetages de tuyauterie pour raccordement avec étanchéité dans le
filet —*

Partie 1: Dimensions, tolérances et désignation



Reference number
ISO 7-1:1994(E)

Foreword

ISO (the International Organization for Standardization) is a worldwide federation of national standards bodies (ISO member bodies). The work of preparing International Standards is normally carried out through ISO technical committees. Each member body interested in a subject for which a technical committee has been established has the right to be represented on that committee. International organizations, governmental and non-governmental, in liaison with ISO, also take part in the work. ISO collaborates closely with the International Electrotechnical Commission (IEC) on all matters of electrotechnical standardization.

Draft International Standards adopted by the technical committees are circulated to the member bodies for voting. Publication as an International Standard requires approval by at least 75 % of the member bodies casting a vote.

International Standard ISO 7-1 was prepared by Technical Committee ISO/TC 5, *Ferrous metal pipes and metallic fittings*, Subcommittee SC 5, *Threaded or plain end butt-welding fittings, threads, gauging of threads*.

This third edition cancels and replaces the second edition (ISO 7-1:1982), which has been technically revised.

ISO 7 consists of the following parts, under the general title *Pipe threads where pressure-tight joints are made on the threads*:

- *Part 1: Dimensions, tolerances and designation*
- *Part 2: Verification by means of limit gauges*

Annex A of this part of ISO 7 is for information only.

© ISO 1994

All rights reserved. Unless otherwise specified, no part of this publication may be reproduced or utilized in any form or by any means, electronic or mechanical, including photocopying and microfilm, without permission in writing from the publisher.

International Organization for Standardization
Case Postale 56 • CH-1211 Genève 20 • Switzerland

Printed in Switzerland

Pipe threads where pressure-tight joints are made on the threads —

Part 1:

Dimensions, tolerances and designation

1 Scope

This part of ISO 7 specifies the requirements for thread form, dimensions, tolerances and designation for jointing pipe threads, sizes 1/16 to 6 inclusive, for joints made pressure-tight by the mating of the threads. These threads are taper external, parallel internal or taper internal and are intended for use with pipes suitable for threading and for valves, fittings or other pipeline equipment interconnected by threaded joints.

An appropriate jointing medium should be used on the thread to ensure pressure-tight joints.

NOTES

- 1 Parallel external pipe threads are not suitable as jointing threads.
- 2 For pipe threads where pressure-tight joints are not made on the threads, see ISO 228-1.
- 3 ISO 7-2 gives details of methods of verification of jointing thread dimensions and form and recommended gauging systems.

2 Normative reference

The following standard contains provisions which, through reference in this text, constitute provisions of this part of ISO 7. At the time of publication, the edition indicated was valid. All standards are subject to revision, and parties to agreements based on this part of ISO 7 are encouraged to investigate the possibility of applying the most recent edition of the standard indicated below. Members of IEC and ISO

maintain registers of currently valid International Standards.

ISO 7-2:1982, *Pipe threads where pressure-tight joints are made on the threads — Part 2: Verification by means of limit gauges.*

3 Definitions

For the purposes of this part of ISO 7, the following definitions apply (see also figures 3 and 5).

3.1 gauge diameter: Major diameter of the thread, whether external or internal.

3.2 major cone: Imaginary cone which just touches the crests of a taper external thread or the roots of a taper internal thread.

3.3 gauge plane: Plane, perpendicular to the axis of the taper thread, at which the major cone has the gauge diameter.

NOTE 4 For external threads the gauge plane is located at a distance equal to the nominal gauge length from the small end of the thread. For internal threads the gauge plane is located at a distance of half-pitch behind the face of the threaded part. This is in order to give consideration to the start of the thread that has been removed by chamfering.

3.4 gauge length: On an external thread, the distance from the gauge plane to the small end of the thread.

3.5 reference plane: Visible surface of each of the internally and externally threaded parts, which facili-

tates the reading of the gauge when the thread is inspected.

For internal threads it is the face of the internally threaded part, for external threads it is the small end of the externally threaded part.

3.6 complete thread: That part of the thread which is fully formed at both crest and root.

NOTE 5 When there is a chamfer at the start of the thread not exceeding one pitch in length, this is included in the length of complete thread.

3.7 incomplete thread: That part of the thread which is fully formed at the root, but truncated at the crest by its intersection with the cylindrical surface of the product.

3.8 washout thread; vanish thread: That part of the thread which is not fully formed at the root.

NOTE 6 The washout thread is produced by the bevel at the start of the threading tool.

3.9 useful thread: Complete thread plus incomplete thread, excluding the washout thread.

3.10 fitting allowance: Length of useful thread beyond the gauge plane of an external thread required to provide for assembly with an internal thread at the upper limit of the tolerance.

NOTE 7 Internally threaded parts will have a sufficient length to accommodate the fitting allowance, except when they have a free run-out. See 7.2.2.

3.11 wrenching allowance: Length of useful thread which is provided to accommodate the relative movement between the end of the externally threaded part and the internally threaded part required for wrenching beyond the position of handtight engagement.

4 Symbols

- Rp Parallel internal pipe thread where pressure-tight joints are made on the threads
- Rc Taper internal pipe thread where pressure-tight joints are made on the threads
- R Taper external pipe thread where pressure-tight joints are made on the threads

- P Pitch
- H Height of the triangle of the thread profile perpendicular to the thread axis
- h = $0,640\ 327\ P$; height of the thread profile between rounded crests and roots perpendicular to the thread axis
- r Radius of rounded crests and roots
- D Major diameter of the internal thread at the gauge plane (gauge diameter — see 3.1)
- D_1 $D - 1,280\ 654\ P$; minor diameter of the internal thread at the gauge plane
- D_2 $D - 0,640\ 327\ P$; pitch diameter of the internal thread at the gauge plane
- d Major diameter of the external thread at the gauge plane (gauge diameter — see 3.1)
- d_1 = $d - 1,280\ 654\ P$; minor diameter of the external thread at the gauge plane
- d_2 = $d - 0,640\ 327\ P$; pitch diameter of the external thread at the gauge plane
- T_1 Tolerance on the gauge length of an external thread
- T_2 Tolerance for the position of the gauge plane on an internal thread

5 Dimensions

Pipe thread dimensions, in millimetres, are given in table 1.

6 Designation

The designation of threads according to this part of ISO 7 shall consist of the following elements in the sequence given:

6.1 The description block shall be:

Pipe thread

6.2 The International Standard number block shall be:

ISO 7

Table 1 — Thread dimensions

Dimensions in millimetres

1	2	3	4	5			6			7			8			9			10			11			12			13			14			15			16			17			18	19	20
				Designation of thread size	Number of threads in 25,4 mm	Pitch P	Height of thread h	Diameters at gauge plane			Gauge length (external thread)			Tolerance on position of gauge plane on internal thread			Length of useful external thread not less than			Fitting allowance	Diametral tolerance ¹⁾ on parallel internal threads																								
Major (gauge diameter) d	Pitch d ₂	Minor d ₁	Nominal					Tolerance ± T _{1/2}	Turns of thread	max.	min.	Tolerance ± T _{1/2}	Turns of thread	For nominal gauge length	For maximum gauge length	For minimum gauge length	2)	2)	2)			2)	2)	2)	2)	2)	2)	2)	2)	2)	2)	2)	2)	2)	2)	2)	2)	2)	2)	2)					
1/16	28	0,907	0,581	7,723	7,142	6,561	4	0,9	1	4,9	3,1	1,1	1 1/4	6,5	7,4	5,6	2,5	23/4	± 0,071																										
1/8	28	0,907	0,581	9,728	9,147	8,566	4	0,9	1	4,9	3,1	1,1	1 1/4	6,5	7,4	5,6	2,5	23/4	± 0,071																										
1/4	19	1,337	0,856	13,157	12,301	11,445	6	1,3	1	7,3	4,7	1,7	1 1/4	9,7	11	8,4	3,7	23/4	± 0,104																										
3/8	19	1,337	0,856	16,662	15,806	14,950	6,4	1,3	1	7,7	5,1	1,7	1 1/4	10,1	11,4	8,8	3,7	23/4	± 0,104																										
1/2	14	1,814	1,162	20,955	19,793	18,631	8,2	1,8	1	10,0	6,4	2,3	1 1/4	13,2	15	11,4	5,0	23/4	± 0,142																										
3/4	14	1,814	1,162	26,441	25,279	24,117	9,5	1,8	1	11,3	7,7	2,3	1 1/4	14,5	16,3	12,7	5,0	23/4	± 0,142																										
1	11	2,309	1,479	33,249	31,770	30,291	10,4	2,3	1	12,7	8,1	2,9	1 1/4	16,8	19,1	14,5	6,4	23/4	± 0,180																										
1 1/4	11	2,309	1,479	41,910	40,431	38,952	12,7	2,3	1	15,0	10,4	2,9	1 1/4	19,1	21,4	16,8	6,4	23/4	± 0,180																										
1 1/2	11	2,309	1,479	47,803	46,324	44,845	12,7	2,3	1	15,0	10,4	2,9	1 1/4	19,1	21,4	16,8	6,4	23/4	± 0,180																										
2	11	2,309	1,479	59,614	58,135	56,656	15,9	2,3	1	18,2	13,6	2,9	1 1/4	23,4	25,7	21,1	7,5	3 1/4	± 0,180																										
2 1/2	11	2,309	1,479	75,184	73,705	72,226	17,5	3,5	1 1/2	21,0	14,0	3,5	1 1/2	26,7	30,2	23,2	9,2	4	± 0,216																										
3	11	2,309	1,479	87,884	86,405	84,926	20,6	3,5	1 1/2	24,1	17,1	3,5	1 1/2	29,8	33,3	26,3	9,2	4	± 0,216																										
4	11	2,309	1,479	113,030	111,551	110,072	25,4	3,5	1 1/2	28,9	21,9	3,5	1 1/2	35,8	39,3	32,3	10,4	4 1/2	± 0,216																										
5	11	2,309	1,479	138,430	136,951	135,472	28,6	3,5	1 1/2	32,1	25,1	3,5	1 1/2	40,1	43,6	36,6	11,5	5	± 0,216																										
6	11	2,309	1,479	163,830	162,351	160,872	28,6	3,5	1 1/2	32,1	25,1	3,5	1 1/2	40,1	43,6	36,6	11,5	5	± 0,216																										

NOTE — The main dimensions were converted into millimetres on the basis of 1 inch = 25,4 mm, beginning with the number of threads per inch, which determines the pitch P, the formula h (the height of thread) = 0,640 327 P and the major diameter at the gauge plane. Pitch diameter and minor diameter were then compiled by subtracting once or twice respectively the height of thread h from the major diameter.

The nominal gauge length, the tolerances and the fitting allowance were directly computed. The remaining lengths given in table 1 were obtained by subtracting or adding the tolerances or fitting allowance respectively to the nominal gauge length. Tolerances and fitting allowance are expressed in millimetres and in number of turns of thread.

- 1) For parallel internally threaded parts the diametral tolerances are derived from the tolerances in column 14 by multiplying with the corresponding pitch in column 3 and with 1/16, the amount of taper.
- 2) Informative tolerances, in millimetres, are obtained from the mandatory values in turns of thread by multiplying with the corresponding pitch in column 3 and rounding to the nearest 0,1 mm.

6.3 The individual item block shall be composed of:

- a) letter symbol(s) for type of pipe thread
 - the letter R followed by the letter p for parallel internal threads;
 - the letter R followed by the letter c for taper (conical) internal threads;
 - the letter R for external threads;
- b) the thread size, from column 1 of table 1.

EXAMPLES

The complete designation for a right-hand thread size 1 1/2:

Internal thread	{ parallel taper	Pipe thread ISO 7 - Rp 1 1/2
		Pipe thread ISO 7 - Rc 1 1/2
External thread	always taper	Pipe thread ISO 7 - R 1 1/2

6.4 For left-hand threads, the letters LH shall be added to the designation. Right-hand threads require no special designation.

7 Thread design

7.1 Thread forms

7.1.1 Parallel thread

The basic form of the parallel pipe thread shall be as shown in figure 1. The angle between the flanks, measured in an axial plane section, is 55°. The thread profiles are rounded equally at crests and roots by circular arcs blending tangentially with the flanks.

7.1.2 Taper thread

The basic form of the taper pipe thread shall be as shown in figure 2. The taper is 1 to 16, measured on the diameter. The angle between the flanks, measured in an axial plane section, is 55°, the flanks making equal angles with the axis.

The thread profiles are rounded off equally at crests and roots by circular arcs blending tangentially with

the flanks in such a manner as to give the same thread height *h* as for parallel threads.

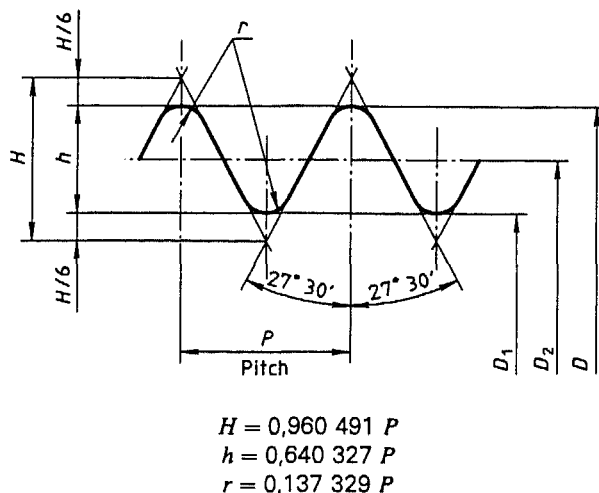

Figure 1 — Parallel thread

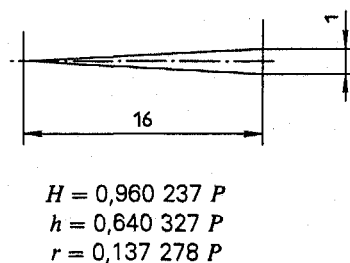
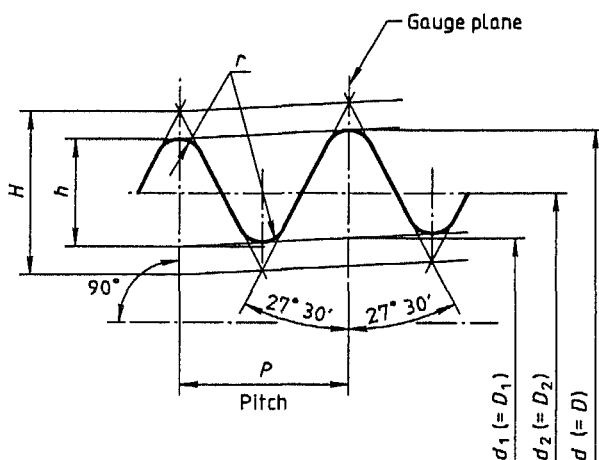

Figure 2 — Taper thread

7.1.3 Direction of thread helix

Unless otherwise specified, the ISO 7-1 thread shall be a right-hand thread. (See also 6.4.)

7.2 Thread lengths

7.2.1 External thread

The terms relating to the external taper pipe thread are given in figure 3.

The length of the useful thread, allowable in practice, is the sum of the lengths of the complete and incomplete threads, excluding the washout thread. The minimum length of the useful thread must be not less than the minimum gauge length plus the fitting allowance.

7.2.2 Internal thread

The design of internally threaded parts shall be such that they can receive external threads up to the lengths given in column 16 of table 1. The minimum lengths L_{\min} of useful thread in the case of internal

threads with free run-out shall be not less than 80 % of the values given in column 17 of table 1. (See figure 4.)

8 Gauging

For the verification of pipe threads, the plug and ring gauges used shall conform to ISO 7-2. The gauging always relates to a reference plane of the threaded part to be verified (see figure 5).

9 Combination with fastening thread

The combination of an external parallel thread G, tolerance class A or B in accordance with ISO 228-1, with an internal parallel thread Rp in accordance with ISO 7-1 needs special consideration.

When it is necessary to have this combination, the positive or negative tolerance of the internal thread to ISO 7-1 shall be considered in the relevant product standards, where external parallel threads G are used.

Such a combination of threads may not necessarily achieve a leak-tight joint.

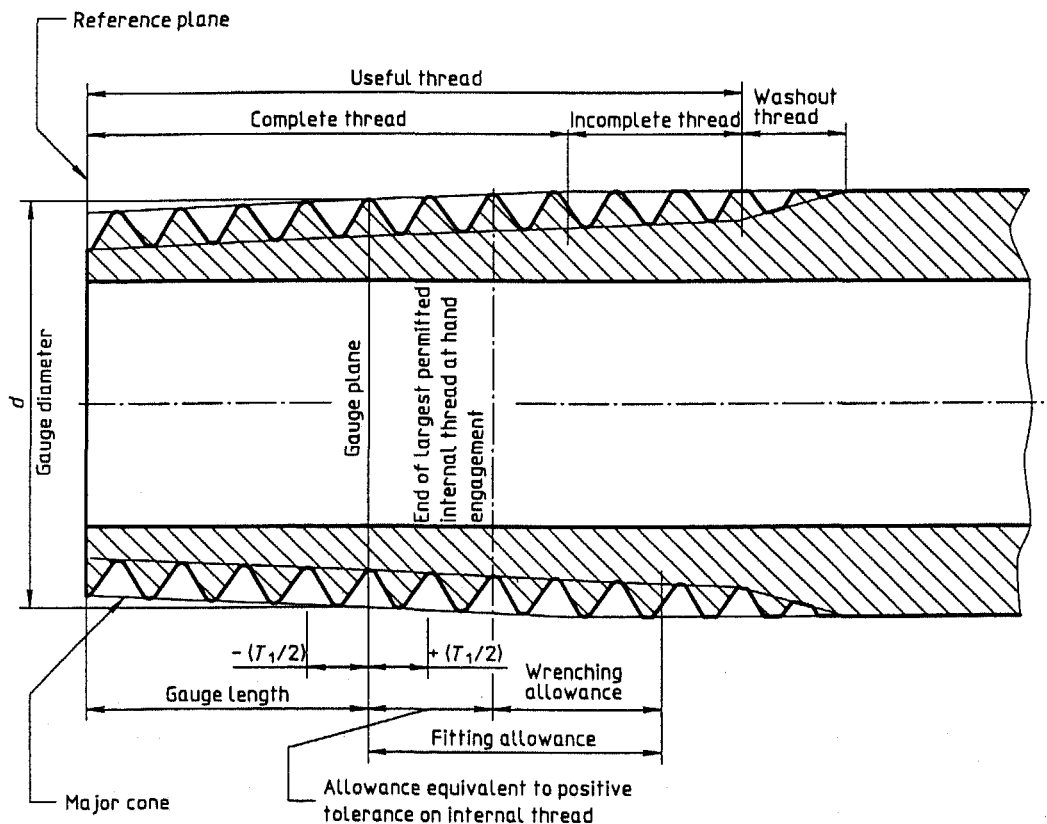

Figure 3 — Terms relating to external threads

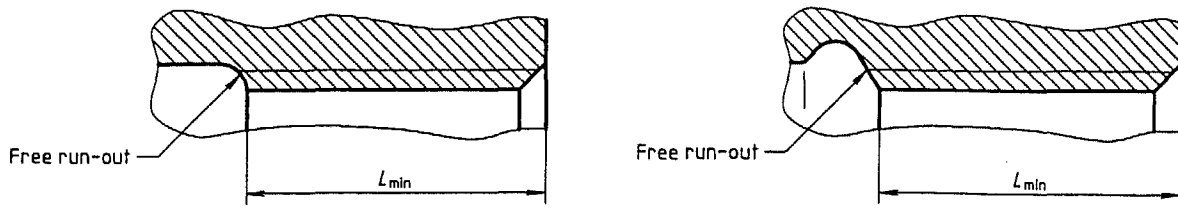

Figure 4 — Internal threads with free run-out

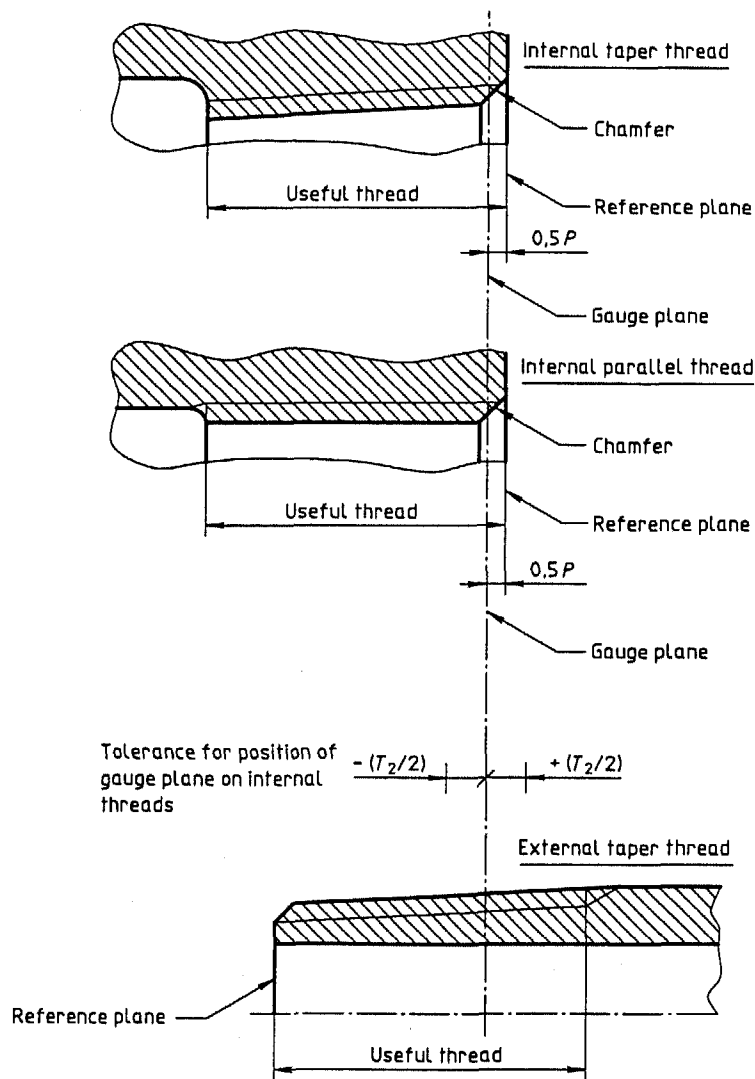

Figure 5 — Illustration of internal and external pipe threads (position of gauge plane, reference plane useful thread)

Annex A
(informative)

Bibliography

- [1] ISO 228-1:1994, *Pipe threads where pressure-tight joints are not made on the threads — Part 1: Dimensions, tolerances and designation.*

ICS 21.040.30

Descriptors: pipe threads, pipe fittings, pipe joints, specifications, dimensions, dimensional tolerances, designation, symbols, gauging.

Price based on 7 pages
