

DIN EN 13757-6

The logo consists of the letters 'DIN' in a bold, sans-serif font, with a horizontal line above and below the letters.

ICS 33.200; 35.100.10; 35.100.20

**Kommunikationssysteme für Zähler und deren Fernablesung –
Teil 6: Lokales Bussystem;
Englische Fassung EN 13757-6:2008**

Communication systems for meters and remote reading of meters –
Part 6: Local Bus;
English version EN 13757-6:2008

Systèmes de communication et de télérelevé de compteurs –
Partie 6: Bus local;
Version anglaise EN 13757-6:2008

Gesamtumfang 10 Seiten

Nationales Vorwort

Dieses Dokument (EN 13757-6:2008) wurde vom Technischen Komitee CEN/TC 294 „Kommunikationssysteme für Zähler und deren Fernablesung“ erarbeitet, dessen Sekretariat vom DS (Dänemark) gehalten wird.

Das zuständige deutsche Gremium ist NA 041-03-66 AA im Normenausschuss Heiz- und Raumlufttechnik (NHRS).

Das Dokument (EN 13757-6:2008) wurde unverändert vom englischen Originaltext übernommen. Der Normenausschuss Heiz- und Raumlufttechnik (NHRS) war für das DIN Deutsches Institut e.V. an der Erstellung dieser Norm beteiligt. Da davon auszugehen ist, dass die Fachleute der Kommunikationstechnik sich bereits mit der englischen Fassung befasst haben, wurde von einer Übersetzung ins Deutsche abgesehen. Nach dem DIN Präsidiumsbeschluss 13/1983 ist auf dem Gebiet der Informatik die Veröffentlichung in Englisch zulässig, insbesondere wenn dadurch Fehler bei der Übersetzung bzw. dem Verständnis der Norm vermieden werden können.

ICS 33.200; 35.100.10; 35.100.20

English Version

Communication systems for meters and remote reading of meters —
Part 6: Local Bus

Systèmes de communication et de télérelevé de compteurs —
Partie 6: Bus local

Kommunikationssysteme für Zähler und deren Fernablesung —
Teil 6: Lokales Bussystem

This European Standard was approved by CEN on 16 August 2008.

CEN members are bound to comply with the CEN/CENELEC Internal Regulations which stipulate the conditions for giving this European Standard the status of a national standard without any alteration. Up-to-date lists and bibliographical references concerning such national standards may be obtained on application to the CEN Management Centre or to any CEN member.

This European Standard exists in three official versions (English, French, German). A version in any other language made by translation under the responsibility of a CEN member into its own language and notified to the CEN Management Centre has the same status as the official versions.

CEN members are the national standards bodies of Austria, Belgium, Bulgaria, Cyprus, Czech Republic, Denmark, Estonia, Finland, France, Germany, Greece, Hungary, Iceland, Ireland, Italy, Latvia, Lithuania, Luxembourg, Malta, Netherlands, Norway, Poland, Portugal, Romania, Slovakia, Slovenia, Spain, Sweden, Switzerland and United Kingdom.



EUROPEAN COMMITTEE FOR STANDARDIZATION
COMITÉ EUROPÉEN DE NORMALISATION
EUROPÄISCHES KOMITEE FÜR NORMUNG

Management Centre: rue de Stassart, 36 B-1050 Brussels

Contents	Page
Foreword	3
Introduction	4
1 Scope	5
2 Normative references	5
3 Physical Layer Specifications	5
Annex A (informative) Schematic implementation of a meter interface	7
Bibliography	8

Foreword

This document (EN 13757-6:2008) has been prepared by Technical Committee CEN/TC 294 "Communication Systems for meters and remote reading of meters", the secretariat of which is held by DS.

This European Standard shall be given the status of a national standard, either by publication of an identical text or by endorsement, at the latest by April 2009, and conflicting national standards shall be withdrawn at the latest by April 2009.

Attention is drawn to the possibility that some of the elements of this document may be the subject of patent rights. CEN [and/or CENELEC] shall not be held responsible for identifying any or all such patent rights.

EN 13757 consists of the following parts, under the general title "Communication systems for meters and remote reading of meters":

- *Part 1: Data exchange*
- *Part 2: Physical and link layer*
- *Part 3: Dedicated application layer*
- *Part 4: Wireless meter readout (Radio meter reading for operation in the 868 MHz to 870 MHz SRD band)*
- *Part 5: Wireless Relaying*
- *Part 6: Local Bus*

According to the CEN/CENELEC Internal Regulations, the national standards organizations of the following countries are bound to implement this European Standard: Austria, Belgium, Bulgaria, Cyprus, Czech Republic, Denmark, Estonia, Finland, France, Germany, Greece, Hungary, Iceland, Ireland, Italy, Latvia, Lithuania, Luxembourg, Malta, Netherlands, Norway, Poland, Portugal, Romania, Slovakia, Slovenia, Spain, Sweden, Switzerland and the United Kingdom.

Introduction

This Standard is part of a series of standards which covers communication systems for meters and remote reading of meters. Part 1 contains generic descriptions and a communication protocol, Part 2 contains the description of the physical and link layer of a universal twisted pair bus system (M-Bus), Part 3 contains a dedicated application layer, Part 4 describes wireless communication and Part 5 describes a relaying extension for the mode R2 of Part 4.

EN 13757-6 can be used with various link and application layers. Frequently, the application layer of EN 13757-3 (M-Bus) or the DLMS based application layer described in EN 13757-1 is used.

An overview of communication systems for meters is given in EN 13757-1, which also contains further definitions.

1 Scope

This standard specifies the physical layer parameters of a local meter readout system ("Local Bus") for the communication with and the readout of a single meter or a small cluster of meters (max. 5) via a single battery powered readout device ("master") which can be connected temporarily or stationary for the communication directly to a meter (i.e. local readout) or via a fixed wiring or a small bus (total cable length max. 50 m, i.e. local remote readout).

For generic descriptions concerning communication systems for meters and remote reading of meters, refer to EN 13757-1.

2 Normative references

The following referenced documents are indispensable for the application of this document. For dated references, only the edition cited applies. For undated references, the latest edition of the referenced document (including any amendments) applies.

EN 13757-2:2004, *Communication systems for and remote reading of meters – Part 2: Physical and link layer*

3 Physical Layer Specifications

The Local Bus is an alternative to the M-Bus. It is restricted to small installations (Minibus installation according to EN 13757-2:2004, Annex E.6.1 type E) and optimized for special battery-driven masters. Usually the readout frequency is limited by the meter. The Local Bus does not support meter power supply from the bus. Note that this meter interface is not compatible with M-Bus masters according to EN 13757-2. To facilitate the meter power management, the master shall switch the bus power on (i.e. enter the master mark send state) not more than 10 s before any meter communication.

NOTE Annex A shows a possible circuit diagram for implementing such an interface.

A meter equipped with a Local Bus interface shall meet the following requirements:

Table 1 — Requirements meter

Parameter	Min.	Max.
Meter Voltage without damage	> ± 50 V	
Isolation from ground	> 1 MOhm	
Meter mark state receive	> ± (UAM - 1 V)	< ± 15 V
Meter space state receive	0 V	< (UAM - 3 V)
Meter mark state send (IBM) 0,5 mA = 1 LUL (Local Bus unit load)	0 mA	< ± 0,5 mA
Voltage compliance of IAM per LUL		< ± 0,05 mA/V
Change of IBM over time per LUL		< ± 50 uA/10 s
Total change of IBM per LUL		< ± 250 uA
Meter space state send	> ± (IBM + 3 mA)	< ± (IBM + 6 mA)
Capacitance per meter		< 0,5 nF
Start-up time after power loss of > 0,1 s or a step change of UAM		< 3 s

A Local Bus master shall meet the following requirements:

Table 2 — Requirements master

Parameter	Min.	Max.
Master mark state send (UAM)	> 4,8 V	< 15 V
Master space state send	0 V	< (UAM - 4 V)
Master mark state current		IAM
Master mark state receive		< IAM + 1 mA
Master space state receive	> IAM + 2 mA	
Master mark state time before communication	> 5 s	< 10 s
Max. number of unit loads (LULs)		6
Max. baud rate	2 400 baud	

Annex A (informative)

Schematic implementation of a meter interface

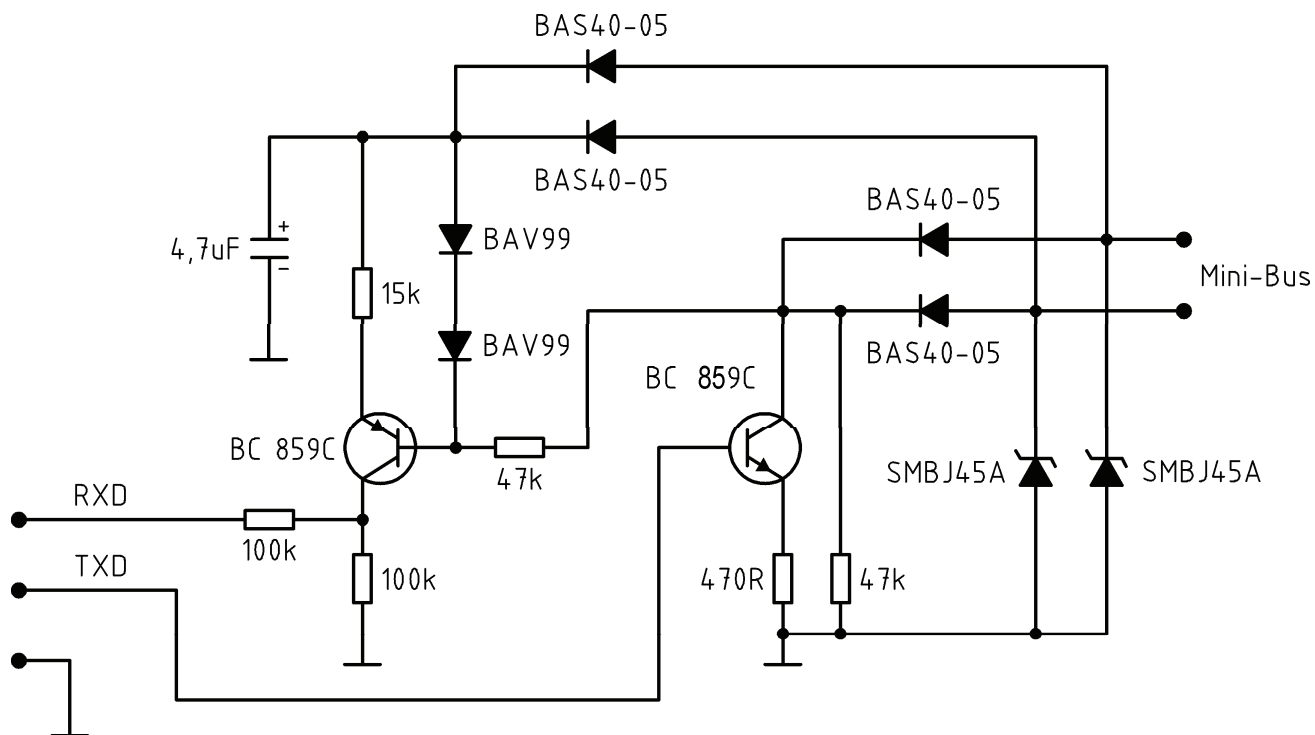

Figure A.1 — Schematic implementation of a meter interface

Bibliography

- [1] EN 1434-3:1997, *Heat meters — Part 3: Data exchange and interfaces*
- [2] EN 13757-1, *Communication system for meters and remote reading of meters – Part 1: Data exchange*
- [3] EN 13757-3, *Communication systems for and remote reading of meters – Part 3: Dedicated application layer*
- [4] EN 13757-4, *Communication systems for meters and remote reading of meters – Part 4: Wireless meter readout (Radio meter reading for operation in the 868 MHz to 870 MHz SRD band)*
- [5] EN 13757-5, *Communication systems for meters and remote reading of meters – Part 5: Wireless Relaying*