



BSI Standards Publication

# Dentistry — Determination of the strength of dental amalgam by the Hertzian indentation strength (HIT) method

**National foreword**

This British Standard is the UK implementation of ISO/TS 20746:2016.

The UK participation in its preparation was entrusted to Technical Committee CH/106/1, Dental restorative and orthodontic materials.

A list of organizations represented on this committee can be obtained on request to its secretary.

This publication does not purport to include all the necessary provisions of a contract. Users are responsible for its correct application.

© The British Standards Institution 2016.  
Published by BSI Standards Limited 2016

ISBN 978 0 580 91396 9

ICS 11.060.10

**Compliance with a British Standard cannot confer immunity from legal obligations.**

This British Standard was published under the authority of the Standards Policy and Strategy Committee on 31 December 2016.

**Amendments/corrigenda issued since publication**

Date	Text affected
------	---------------

---

First edition  
2016-12-15

---

---

**Dentistry — Determination of the  
strength of dental amalgam by the  
Hertzian indentation strength (HIT)  
method**

*Médecine bucco-dentaire — Détermination de la résistance des  
amalgames dentaire par l'indentation hertzienne (HIT) méthode*



Reference number  
ISO/TS 20746:2016(E)

© ISO 2016



## **COPYRIGHT PROTECTED DOCUMENT**

© ISO 2016, Published in Switzerland

All rights reserved. Unless otherwise specified, no part of this publication may be reproduced or utilized otherwise in any form or by any means, electronic or mechanical, including photocopying, or posting on the internet or an intranet, without prior written permission. Permission can be requested from either ISO at the address below or ISO's member body in the country of the requester.

ISO copyright office  
Ch. de Blandonnet 8 • CP 401  
CH-1214 Vernier, Geneva, Switzerland  
Tel. +41 22 749 01 11  
Fax +41 22 749 09 47  
copyright@iso.org  
www.iso.org

# Contents

	Page
<b>Foreword</b> .....	<b>iv</b>
<b>Introduction</b> .....	<b>v</b>
<b>1 Scope</b> .....	<b>1</b>
<b>2 Normative references</b> .....	<b>1</b>
<b>3 Terms and definitions</b> .....	<b>1</b>
<b>4 Hertzian indentation strength test (HIT) applied to dental amalgam</b> .....	<b>2</b>
<b>5 Apparatus for the production of test-pieces</b> .....	<b>3</b>
5.1 Equipment.....	3
5.2 Specifications for the mould.....	4
<b>6 Sampling</b> .....	<b>4</b>
<b>7 Preparation of dental amalgam test-pieces</b> .....	<b>4</b>
7.1 Mixing the dental amalgam.....	4
7.2 Test-piece production.....	5
7.2.1 Packing the mould, removal of the test-piece and inspection for surface defects..	5
7.3 Measurement of the test-piece and storage prior to testing.....	5
7.3.1 Equipment.....	5
7.3.2 General.....	6
<b>8 Test procedure</b> .....	<b>6</b>
8.1 Apparatus.....	6
8.2 Mechanical testing.....	6
<b>9 Treatment of data and reporting of results</b> .....	<b>7</b>
<b>Bibliography</b> .....	<b>8</b>

## Foreword

ISO (the International Organization for Standardization) is a worldwide federation of national standards bodies (ISO member bodies). The work of preparing International Standards is normally carried out through ISO technical committees. Each member body interested in a subject for which a technical committee has been established has the right to be represented on that committee. International organizations, governmental and non-governmental, in liaison with ISO, also take part in the work. ISO collaborates closely with the International Electrotechnical Commission (IEC) on all matters of electrotechnical standardization.

The procedures used to develop this document and those intended for its further maintenance are described in the ISO/IEC Directives, Part 1. In particular the different approval criteria needed for the different types of ISO documents should be noted. This document was drafted in accordance with the editorial rules of the ISO/IEC Directives, Part 2 (see [www.iso.org/directives](http://www.iso.org/directives)).

Attention is drawn to the possibility that some of the elements of this document may be the subject of patent rights. ISO shall not be held responsible for identifying any or all such patent rights. Details of any patent rights identified during the development of the document will be in the Introduction and/or on the ISO list of patent declarations received (see [www.iso.org/patents](http://www.iso.org/patents)).

Any trade name used in this document is information given for the convenience of users and does not constitute an endorsement.

For an explanation on the meaning of ISO specific terms and expressions related to conformity assessment, as well as information about ISO's adherence to the World Trade Organization (WTO) principles in the Technical Barriers to Trade (TBT) see the following URL: [www.iso.org/iso/foreword.html](http://www.iso.org/iso/foreword.html).

The committee responsible for this document is ISO/TC 106, *Dentistry*, Subcommittee SC 1, *Filling and restorative materials*.

## Introduction

This document gives the practical details of the test method for the measurement of the strength of a dental amalgam by the Hertzian indentation (HIT) method. In this test, the specimen geometry and the localized application of force leads to radial crack formation at the surface opposite the one to which the force is applied and under the point at which it is applied. This protocol produces a loading condition similar to that encountered during normal oral function.

When a requirement is agreed, it is the intention of ISO/TC 106/SC 1 to consider the inclusion of this test procedure in the ISO standards for dental amalgam.

This method for measuring the strength of a brittle material (and materials that have very low plasticity) can be applied to other dental restorative materials.





# Dentistry — Determination of the strength of dental amalgam by the Hertzian indentation strength (HIT) method

## 1 Scope

This document gives the practical details of the test method for the measurement of the strength of a dental amalgam by the Hertzian indentation strength test (HIT) method.

It is applicable to dental amalgam formed from products that are within the scope of ISO 24234 and ISO 20749.

## 2 Normative references

The following documents are referred to in the text in such a way that some or all of their content constitutes requirements of this document. For dated references, only the edition cited applies. For undated references, the latest edition of the referenced document (including any amendments) applies.

ISO 6344-1, *Coated abrasives — Grain size analysis — Part 1: Grain size distribution test*

ISO 7488, *Dental amalgamators*

ISO 13565-2, *Geometrical Product Specifications (GPS) — Surface texture: Profile method; Surfaces having stratified functional properties — Part 2: Height characterization using the linear material ratio curve*

ISO 13897, *Dentistry — Amalgam capsules*

ISO 24234, *Dentistry — Dental amalgam*

## 3 Terms and definitions

For the purposes of this document, the terms and definitions given in ISO 1942 and the following apply.

ISO and IEC maintain terminological databases for use in standardization at the following addresses:

- IEC Electropedia: available at <http://www.electropedia.org/>
- ISO Online browsing platform: available at <http://www.iso.org/obp>

### 3.1

#### **dental amalgam alloy**

alloy in fine particles, composed mainly of silver, tin and copper, which, when mixed with *dental mercury* (3.2), produces a dental amalgam

### 3.2

#### **dental mercury**

mercury supplied for use in the preparation of dental amalgam

### 3.3 pre-capsulated dental amalgam product

dental amalgam product supplied in a sealed capsule that contains measured amounts of *dental amalgam alloy* (3.1) powder and *dental mercury* (3.2) with masses that are appropriate for the production of a mass of dental amalgam that is considered to be suitable for a single small or medium size restoration in a single tooth

Note 1 to entry: The dental amalgam alloy powder and dental mercury are separated by a barrier that is broken immediately prior to mixing to allow their contact. The capsule remains sealed until mixing has been completed.

### 3.4 dental amalgam alloy tablet

*dental amalgam alloy* (3.1) powder that has been compressed to form a single entity for the purpose of providing a pre-dosed quantity of the alloy that, when mixed with an appropriate mass of *dental mercury* (3.2), produces a mass of dental amalgam that is considered to be suitable for a single small or medium size restoration in a single tooth

Note 1 to entry: During mixing, the tablet is intended to break apart, forming a fine powder.

### 3.5 dental mercury sachet

measured quantity of *dental mercury* (3.2) supplied in a sachet (for use in a reusable mixing capsule) in a mass that, when mixed with an appropriate mass of *dental amalgam alloy* (3.1), produces a mass of dental amalgam that is considered to be suitable for a single small or medium size restoration in a single tooth

Note 1 to entry: The sachet is intended to rupture during mixing to allow the dental mercury to come into contact with the dental amalgam alloy.

### 3.6 top surface of the test-piece

surface of the disc shaped test-piece that has been produced by carving back unset amalgam that is above the level of the mould until the surface of the test-piece is flat and level with that mould surface

### 3.7 test surface of the test-piece

surface of the disc-shaped test-piece that has been produced by contact with the polished glass plate when the mixed amalgam is packed into the mould

### 3.8 radial cracking

fracture pattern of Hertzian indentation test-piece disc in which (more or less) planar cracks form along radii, normal to the face of the disc, thus dissecting it into two or more sectors

EXAMPLE Some radial fracture patterns in disc shaped test-pieces are illustrated here.



Note 1 to entry: Such radial cracks initiate on the test surface of the test-piece and propagate through the disc to produce approximately equiangular dissection in most cases.

## 4 Hertzian indentation strength test (HIT) applied to dental amalgam

This test utilizes a disc-shaped test-piece to which a linearly increasing force is applied through a hard steel ball sited at the centre of one of the flat faces of the disc. The other face of the disc is in contact with a smooth substrate that is also disc shaped and thicker than the test-piece. The substrate has a Young's modulus value that is of the same order as that of dentine. Fracture is produced by radial cracks initiating at the surface in contact with the substrate. By having close control of the test-piece, the

resistance to fracture is quantified by the fracture force. Dental amalgam products are compared using the values of the fracture force.

A vertical section through the apparatus required for testing is shown in [Figure 1](#).

Dimensions in millimetres

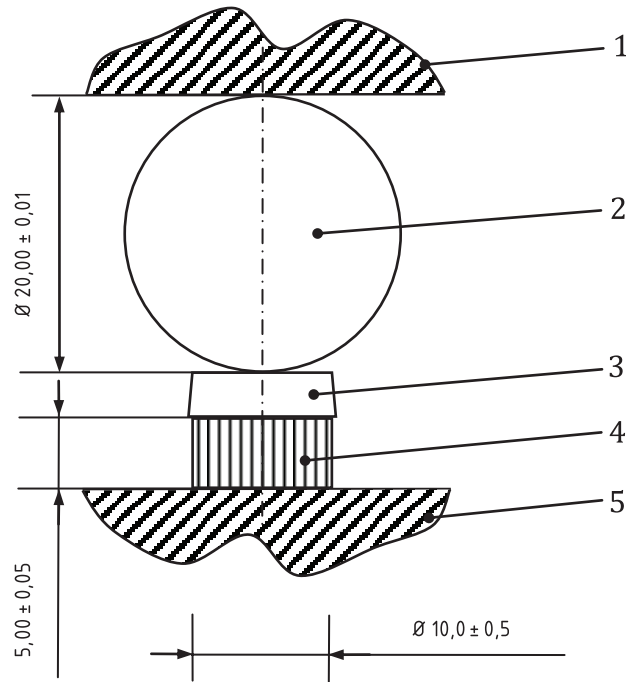

**Key**

- 1 universal mechanical testing machine upper compression platen
- 2 chrome steel bearing ball
- 3 dental amalgam test-piece (see [Figure 2](#) for the dimensions and dimensional tolerances for this)
- 4 30 % glass-filled polyamide disc
- 5 universal mechanical testing machine lower compression platen

**Figure 1 — Loading arrangement for the Hertzian indentation strength test (HIT)**

## 5 Apparatus for the production of test-pieces

### 5.1 Equipment

5.1.1 Mould, as shown in [Figure 2](#).

5.1.2 Flat square scratch-free polished **glass plate** with an edge length greater than 30 mm.

5.1.3 Glass **microscope slide** to provide a straight edge to carve back the dental amalgam.

5.1.4 **Hand-instrument for dental amalgam packing.**

5.1.5 **Dental amalgam mechanical mixer.**

## 5.2 Specifications for the mould

The mould shall be made of hardened tool steel or hardened stainless steel. The upper and lower surfaces shall be flat and parallel and have a core roughness depth ( $R_k$ ) not greater than  $6,3 \mu\text{m}$  when tested in accordance with ISO 13565-2. The hole shall have a taper of  $(7 \pm 2)^\circ$  to allow the amalgam disc to be ejected without undue force when this is applied to the face that has the smaller diameter for the hole. The tapered surface shall be smooth enough not to impede the ejection of the test-piece. For example, it may be honed to a core roughness depth ( $R_k$ ) of  $6,3 \mu\text{m}$  (when tested in accordance with ISO 13565-2).

NOTE 1 For convenience, to distinguish between the two surfaces during test-piece production, a small engraved mark (set away from the hole) can be made on one of the mould faces.

NOTE 2 The angle of the taper,  $(7 \pm 2)^\circ$ , is the included angle. The wall of the mould is at an angle of  $(3,5 \pm 1,0)^\circ$  with the centre line.

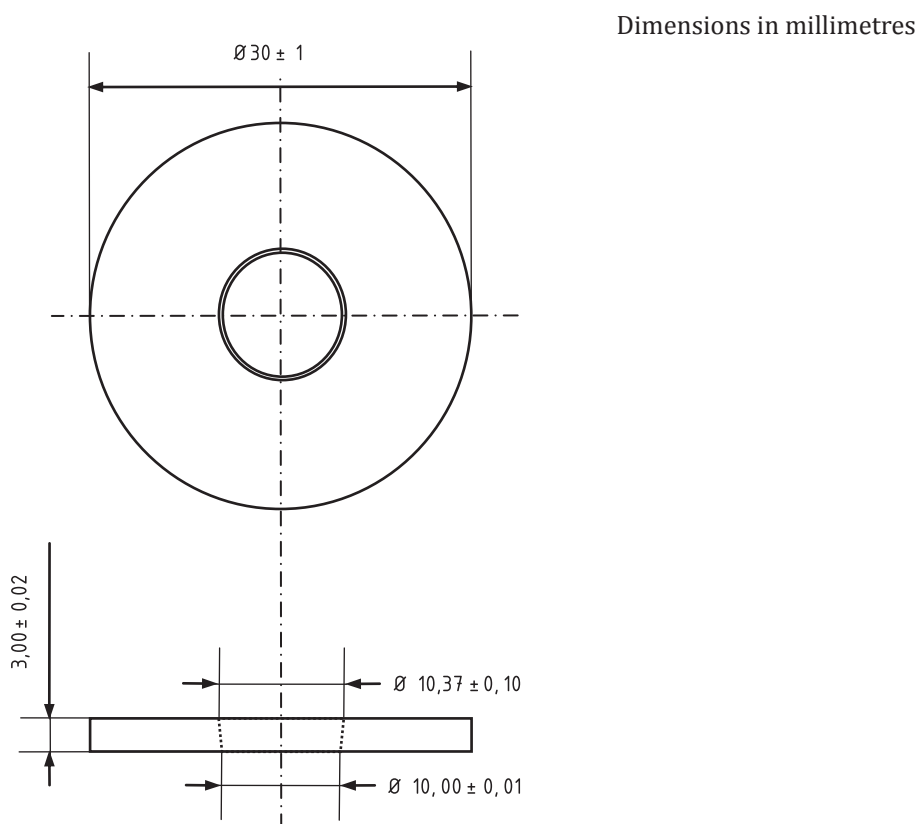

Figure 2 — Mould to produce test-pieces for the Hertzian indentation strength test (HIT)

## 6 Sampling

Procure sufficient dental amalgam alloy and dental mercury from single lots that have been produced for retail. The required mass of dental amalgam alloy will depend upon the dental amalgam alloy: dental mercury mixing ratio. Depending on the product, a total of the order  $3,2 \text{ g}$  of mixed amalgam will be required for each test-piece.

## 7 Preparation of dental amalgam test-pieces

### 7.1 Mixing the dental amalgam

Prepare test-pieces at  $(23 \pm 2)^\circ\text{C}$ .

For a dental amalgam alloy product supplied either as tablets or as a free-flowing powder in bulk, the ratio by mass of the dental amalgam alloy to that of the dental mercury shall be the ratio recommended by the manufacturer. Use dental mercury sachets that comply with ISO 24234. Use a capsule (with a pestle, if needed) that complies with Type 2 of ISO 13897. Use any other mixing accessory that is required, as recommended by the manufacturer. If more than one mix is required to make the test-piece, produce these mixes simultaneously using equipment of the same type for each mix. However, if the last mix can be produced within the working time of the first mix, mixing these masses sequentially on a single piece of equipment is allowed.

For pre-capsulated products, use as many capsules as needed. Mix the contents of the capsules either simultaneously using the same number of pieces of equipment of the same type, or sequentially on a single piece of equipment. (The latter is allowed, provided the mixing of the last capsule is completed before the end of the working time of the first.) If necessary, use only a portion of the dental amalgam mix from one of these capsules.

Use a mechanical mixing machine for dental amalgam that complies with ISO 7488 and that is recommended for mixing the dental amalgam alloy product with dental mercury or mixing the pre-capsulated product. Use the dental amalgam mechanical mixer setting and mixing time that is recommended by the manufacturer of the dental amalgam alloy or pre-capsulated product (for the mass of dental amalgam alloy that is being mixed).

Mix a mass of the dental amalgam sufficient to make a disc-shaped test-piece that is 10 mm in diameter and 3 mm high after packing into the mould shown in [Figure 2](#).

## 7.2 Test-piece production

### 7.2.1 Packing the mould, removal of the test-piece and inspection for surface defects

Place the steel mould on the glass plate with the side that has the greater diameter for the tapered hole in contact with the plate.

NOTE The surface of the glass plate acts as a matrix for the test surface of the test-piece.

Pack the dental amalgam by hand, overfilling slightly. Carve back using the edge of the microscope slide to produce a flat surface (on the dental amalgam) that is level with that of the mould surface.

Allow the dental amalgam to set for 10 min. Carefully eject the test-piece from the mould by applying light finger-pressure to the surface of the test-piece that had been carved back (i.e. the “top surface”), while holding the mould in the other hand. Check visually that the “test surface” is defect-free everywhere, other than possibly at the margin. Use visual inspection without magnification. Carry out this inspection at an illuminance of at least 1 000 lx and at a distance not exceeding 250 mm. A person making the inspection shall have nominally normal visual acuity. Corrective (non-magnifying) untinted lenses may be worn. If a defect is detected, reject that test-piece and make a replacement.

To prevent any damage to the test surface during ejection, placing a thick soft pad (such as dental napkins) under the mould to “catch” the ejected test-piece is recommended.

After ejection, do not grind or polish the surfaces of the test-piece.

## 7.3 Measurement of the test-piece and storage prior to testing

### 7.3.1 Equipment

**7.3.1.1 Micrometre screw gauge** (with flat anvils that are at least 6 mm in diameter) or a similar measuring instrument, to measure the test-piece thickness to an accuracy of 0,01 mm.

NOTE Flat anvils with such a diameter are required to minimize the possibility of surface marking.

**7.3.1.2 Air oven** or incubator maintained at  $(37 \pm 2)$  °C.

### 7.3.2 General

Measure the thickness of the test-piece to an accuracy of 0,01 mm. Take care not to mark the surfaces when the test-piece is placed between the anvils of the micrometre and they are closed onto the surfaces. If the thickness is outside the range (3,00 ± 0,01) mm, reject this test-piece and replace it with another.

After removing the test-piece from the micrometre, inspect the test surface to determine whether it has been marked during measurement. Carry out this inspection at an illuminance of at least 1 000 lx and at a distance not exceeding 250 mm. A person making the inspection shall have nominally normal visual acuity. Corrective (non-magnifying) untinted lenses may be worn. If marking is seen, reject and replace the test-piece.

Immediately after this inspection, place the test-piece in an air oven or incubator maintained at (37 ± 2) °C.

Make 10 test-pieces. Store these test-pieces for the specified time period.

**NOTE** The storage time is not specified in this document. The decision on this will be made when the test is adopted in the ISO standards on dental amalgam. For any other application, the user can select a time appropriate for the investigation being undertaken.

After the storage period, remove the test-pieces from the oven, taking care not to touch the test surface.

Place the test-pieces with the test surface upwards on a clean and flat surface. Leave to allow them to equilibrate with the ambient temperature.

## 8 Test procedure

### 8.1 Apparatus

**8.1.1 Bearing ball**, chrome steel, minimum Vickers' hardness 7,0 GPa, polished surface, 20 mm in diameter.

**8.1.2 Substrate disc**, dimensions: 10 mm in diameter and 5,00 mm thick. The Young's modulus of this disc is (10 ± 1) GPa. 30 % glass-filled polyamide rod<sup>1)</sup> is a suitable material. Lathe-cutting the disc from such a rod is recommended. If necessary, wet-grind the end faces under light pressure on coated abrasives (that comply with micro-grit size P1200 in accordance with ISO 6344-1) to remove any lathe turning marks.

**8.1.3 Universal mechanical testing machine** with compression testing facility. Load cell capacity 5 kN. Minimum data acquisition rate: 100 data points/s.

### 8.2 Mechanical testing

(20 ± 5) min after a test-piece has been removed from the oven (or incubator), place it centrally with its test surface downward on the glass-filled polyamide disc (which is placed centrally on the lower compression platen of the universal mechanical testing machine), i.e. the test surface is to be in contact with the filled polyamide disc. The steel loading ball is positioned centrally on the upper surface of the dental amalgam test-piece (see [Figure 1](#)).

The designs of mechanical testing machines are various. For this reason, the means by which the ball is accurately located and fixed to the upper platen (and centred on the test-piece) is not prescribed. Adopt an appropriate solution. However, the arrangement should have a high axial stiffness.

---

1) Polyamide – Nylon 6,6 – 30 % glass fibre reinforced — Rod. (PA 6,6 30 %GFR) is an example of a suitable product available commercially. This information is given for the convenience of users of this document and does not constitute an endorsement by ISO of this product.

Apply force to the test-piece using a cross-head speed of 0,2 mm/min, collecting the force vs. displacement values digitally at an acquisition rate of at least 100 data points/s. Record the force at which fracture occurs.

**NOTE** In the absence of explosive fracture, the continued presence of material under the ball maintains a finite force. In such a circumstance, there are several methods available to determine the fracture force: acoustic emission, or load-cell ringing, or a clear force drop, or a discontinuity in the force vs. displacement output in the case of a “silent” fracture.

It is possible that incomplete separation will exist in a failed test-piece. Under such a circumstance, use gentle finger-pressure to complete the separation (after the test-piece is removed from the testing machine).

Collect and piece together the test-piece fragments. Determine whether radial dissection has occurred by ascertaining, using visual inspection without magnification, whether bottom-initiated radial fracture has taken place. Carry out this inspection at an illuminance of at least 1 000 lx and at a distance not exceeding 250 mm. A person making the inspection shall have nominally normal visual acuity. Corrective (non-magnifying) untinted lenses may be worn. If it has not so fractured, the result is to be rejected.

Fracture of a test-piece can produce between two and five fragments. The result is still valid if more than two fragments are produced, provided that bottom-initiated radial fracture has occurred.

Load all 10 test-pieces to fracture.

For each test-piece, record the force (in newtons) at which fracture occurs and whether failure is valid or not.

## **9 Treatment of data and reporting of results**

Report all test results. Include any result that has not been accepted with the reason for this rejection.

Calculate the mean value for the accepted results for the test-pieces. Report this.

## Bibliography

- [1] ISO 1942, *Dentistry — Vocabulary*
- [2] ISO 20749, *Dentistry — Pre-capsulated dental amalgam*
- [3] DARVELL B.W. Development of strength in dental silver amalgam. *Dent. Mater.* 2012, **28** pp. e207–e217
- [4] DARVELL B.W. Effect of corrosion on the strength of dental silver amalgam. *Dent. Mater.* 2012, **28** pp. e160–e168









# British Standards Institution (BSI)

BSI is the national body responsible for preparing British Standards and other standards-related publications, information and services.

BSI is incorporated by Royal Charter. British Standards and other standardization products are published by BSI Standards Limited.

## About us

We bring together business, industry, government, consumers, innovators and others to shape their combined experience and expertise into standards-based solutions.

The knowledge embodied in our standards has been carefully assembled in a dependable format and refined through our open consultation process. Organizations of all sizes and across all sectors choose standards to help them achieve their goals.

## Information on standards

We can provide you with the knowledge that your organization needs to succeed. Find out more about British Standards by visiting our website at [bsigroup.com/standards](http://bsigroup.com/standards) or contacting our Customer Services team or Knowledge Centre.

## Buying standards

You can buy and download PDF versions of BSI publications, including British and adopted European and international standards, through our website at [bsigroup.com/shop](http://bsigroup.com/shop), where hard copies can also be purchased.

If you need international and foreign standards from other Standards Development Organizations, hard copies can be ordered from our Customer Services team.

## Copyright in BSI publications

All the content in BSI publications, including British Standards, is the property of and copyrighted by BSI or some person or entity that owns copyright in the information used (such as the international standardization bodies) and has formally licensed such information to BSI for commercial publication and use.

Save for the provisions below, you may not transfer, share or disseminate any portion of the standard to any other person. You may not adapt, distribute, commercially exploit, or publicly display the standard or any portion thereof in any manner whatsoever without BSI's prior written consent.

## Storing and using standards

Standards purchased in soft copy format:

- A British Standard purchased in soft copy format is licensed to a sole named user for personal or internal company use only.
- The standard may be stored on more than 1 device provided that it is accessible by the sole named user only and that only 1 copy is accessed at any one time.
- A single paper copy may be printed for personal or internal company use only.

Standards purchased in hard copy format:

- A British Standard purchased in hard copy format is for personal or internal company use only.
- It may not be further reproduced – in any format – to create an additional copy. This includes scanning of the document.

If you need more than 1 copy of the document, or if you wish to share the document on an internal network, you can save money by choosing a subscription product (see 'Subscriptions').

## Reproducing extracts

For permission to reproduce content from BSI publications contact the BSI Copyright & Licensing team.

## Subscriptions

Our range of subscription services are designed to make using standards easier for you. For further information on our subscription products go to [bsigroup.com/subscriptions](http://bsigroup.com/subscriptions).

With **British Standards Online (BSOL)** you'll have instant access to over 55,000 British and adopted European and international standards from your desktop. It's available 24/7 and is refreshed daily so you'll always be up to date.

You can keep in touch with standards developments and receive substantial discounts on the purchase price of standards, both in single copy and subscription format, by becoming a **BSI Subscribing Member**.

**PLUS** is an updating service exclusive to BSI Subscribing Members. You will automatically receive the latest hard copy of your standards when they're revised or replaced.

To find out more about becoming a BSI Subscribing Member and the benefits of membership, please visit [bsigroup.com/shop](http://bsigroup.com/shop).

With a **Multi-User Network Licence (MUNL)** you are able to host standards publications on your intranet. Licences can cover as few or as many users as you wish. With updates supplied as soon as they're available, you can be sure your documentation is current. For further information, email [subscriptions@bsigroup.com](mailto:subscriptions@bsigroup.com).

## Revisions

Our British Standards and other publications are updated by amendment or revision.

We continually improve the quality of our products and services to benefit your business. If you find an inaccuracy or ambiguity within a British Standard or other BSI publication please inform the Knowledge Centre.

## Useful Contacts

### Customer Services

**Tel:** +44 345 086 9001

**Email (orders):** [orders@bsigroup.com](mailto:orders@bsigroup.com)

**Email (enquiries):** [cservices@bsigroup.com](mailto:cservices@bsigroup.com)

### Subscriptions

**Tel:** +44 345 086 9001

**Email:** [subscriptions@bsigroup.com](mailto:subscriptions@bsigroup.com)

### Knowledge Centre

**Tel:** +44 20 8996 7004

**Email:** [knowledgecentre@bsigroup.com](mailto:knowledgecentre@bsigroup.com)

### Copyright & Licensing

**Tel:** +44 20 8996 7070

**Email:** [copyright@bsigroup.com](mailto:copyright@bsigroup.com)

### BSI Group Headquarters

389 Chiswick High Road London W4 4AL UK