

PD ISO/TS 19150-1:2012



BSI Standards Publication

Geographic information — Ontology

Part 1: Framework

bsi.

...making excellence a habit.™

National foreword

This Published Document is the UK implementation of ISO/TS 19150-1:2012.

The UK participation in its preparation was entrusted to Technical Committee IST/36, Geographic information.

A list of organizations represented on this committee can be obtained on request to its secretary.

This publication does not purport to include all the necessary provisions of a contract. Users are responsible for its correct application.

© The British Standards Institution 2012. Published by BSI Standards Limited 2012

ISBN 978 0 580 76149 2

ICS 35.240.70

Compliance with a British Standard cannot confer immunity from legal obligations.

This Published Document was published under the authority of the Standards Policy and Strategy Committee on 31 December 2012.

Amendments issued since publication

Date	Text affected
------	---------------

TECHNICAL
SPECIFICATION

ISO/TS
19150-1

First edition
2012-11-15

Geographic information — Ontology —
Part 1:
Framework

Information géographique — Ontologie —
Partie 1: Cadre de travail



Reference number
ISO/TS 19150-1:2012(E)

© ISO 2012



COPYRIGHT PROTECTED DOCUMENT

© ISO 2012

All rights reserved. Unless otherwise specified, no part of this publication may be reproduced or utilized in any form or by any means, electronic or mechanical, including photocopying and microfilm, without permission in writing from either ISO at the address below or ISO's member body in the country of the requester.

ISO copyright office
Case postale 56 • CH-1211 Geneva 20
Tel. + 41 22 749 01 11
Fax + 41 22 749 09 47
E-mail copyright@iso.org
Web www.iso.org

Published in Switzerland

Contents

	Page
Foreword	iv
Introduction	v
1 Scope	1
2 Conformance	1
3 Normative references	1
4 Terms and definitions	1
5 Symbols and abbreviated terms	3
6 Ontology in geographic information	4
6.1 Introduction.....	4
6.2 Values of ontologies.....	4
6.3 Issues of relevance.....	5
7 Framework	5
7.1 Overview of the framework.....	5
7.2 Rules for developing ontologies in the Web Ontology Language.....	7
7.3 Semantic operators.....	7
7.4 Service ontology.....	7
7.5 Domain ontology registry.....	9
7.6 Service ontology registry.....	9
7.7 Harmonized ontologies.....	9
7.8 Framework package dependencies.....	9
Annex A (normative) Abstract test suite	10
Annex B (informative) Background information on ontologies	16
Annex C (informative) Ontology matching	27
Bibliography	29

Foreword

ISO (the International Organization for Standardization) is a worldwide federation of national standards bodies (ISO member bodies). The work of preparing International Standards is normally carried out through ISO technical committees. Each member body interested in a subject for which a technical committee has been established has the right to be represented on that committee. International organizations, governmental and non-governmental, in liaison with ISO, also take part in the work. ISO collaborates closely with the International Electrotechnical Commission (IEC) on all matters of electrotechnical standardization.

International Standards are drafted in accordance with the rules given in the ISO/IEC Directives, Part 2.

The main task of technical committees is to prepare International Standards. Draft International Standards adopted by the technical committees are circulated to the member bodies for voting. Publication as an International Standard requires approval by at least 75 % of the member bodies casting a vote.

In other circumstances, particularly when there is an urgent market requirement for such documents, a technical committee may decide to publish other types of normative document:

- an ISO Publicly Available Specification (ISO/PAS) represents an agreement between technical experts in an ISO working group and is accepted for publication if it is approved by more than 50 % of the members of the parent committee casting a vote;
- an ISO Technical Specification (ISO/TS) represents an agreement between the members of a technical committee and is accepted for publication if it is approved by 2/3 of the members of the committee casting a vote.

An ISO/PAS or ISO/TS is reviewed after three years in order to decide whether it will be confirmed for a further three years, revised to become an International Standard, or withdrawn. If the ISO/PAS or ISO/TS is confirmed, it is reviewed again after a further three years, at which time it must either be transformed into an International Standard or be withdrawn.

Attention is drawn to the possibility that some of the elements of this document may be the subject of patent rights. ISO shall not be held responsible for identifying any or all such patent rights.

ISO/TS 19150-1 was prepared by Technical Committee ISO/TC 211, *Geographic information/Geomatics*.

ISO/TS 19150 consists of the following parts, under the general title *Geographic information — Ontology*:

- *Part 1: Framework*
- *Part 2: Rules for developing ontologies in the Web Ontology Language (OWL)¹⁾*

The following parts are under development:

- *Part 3: Semantic operators*
- *Part 4: Service ontology*
- *Part 5: Domain ontology registry*
- *Part 6: Service ontology registry*

1) To be published.

Introduction

For more than two decades (since the World Wide Web was established) the web has been a network of data with proper syntax (structure) but without any meaning (semantics) to the machine. The Semantic Web has introduced the Web of data. The Semantic Web became an extension of the already existing web of data, by adding machine-processable data (with embedded semantics) as opposed to just documents. It can be seen as a tremendous worldwide open database that people can query from their own perspective, understanding, or abstraction of real world phenomena or events and get accurate, detailed, and appropriate answers. This approach involves reasoning capabilities based on ontologies. Following this path the notion of “Linked Data” has been introduced for data of various kinds, coming from different sources, to be connected together on the Web by the way of HTTP URIs. As a consequence, the Semantic Web and Linked Data bring new opportunities for the geographic information realm to lay out a new generation of standards in order to benefit from these in achieving semantic interoperability of geographic information.

Ontology consists of a formal representation of phenomena of a universe of discourse with an underlying vocabulary including definitions and axioms that make the intended meaning explicit and describe phenomena and their interrelationships. It supports the representation of concepts that supports the interpretation of data and reasoning to concur to semantic interoperability. Data from different disciplines including geographic information can be integrated and contribute to addressing from specific (e.g. oil spill) to global problems (e.g. climate change).

This Technical Specification defines a high level framework that structures the standards specifically addressing the semantics of geographic information through ontologies. The proposed other parts of the framework include:

ISO 19150-2, *Geographic information — Ontology — Part 2: Rules for developing ontologies in the Web Ontology Language (OWL)*, defines rules and guidelines for the development of ontologies in OWL-DL, including a mapping between UML class diagram elements and OWL-DL and rules for describing application schemas in OWL-DL.

ISO 19150-3, *Geographic information — Ontology — Part 3: Semantic operators*, defines semantic proximity operators between concepts that complement geometric and temporal operators.

ISO 19150-4, *Geographic information — Ontology — Part 4: Service ontology*, identifies the framework for service ontology and defines the description of Web services for geographic information in an ontology language.

ISO 19150-5, *Geographic information — Ontology — Part 5: Domain ontology registry*, defines an international registry of geographic information domain ontologies and its maintenance.

ISO 19150-6, *Geographic information — Ontology — Part 6: Service ontology registry*, defines an international registry of geographic information service ontologies and its maintenance.

These parts are completed with the ISO/TC 211 Harmonized ontologies that consist of a set of OWL-DL ontologies that translate and complement the ISO/TC 211 Harmonized models developed in UML.

This Technical Specification is intended to be used primarily by standards developers in geographic information. It can also benefit information system analysts, program planners and developers of ISO geographic information standards. It will improve understanding of the basic principles of semantic interoperability and their consistent application to geographic information.

Geographic information — Ontology —

Part 1: Framework

1 Scope

This Technical Specification defines the framework for semantic interoperability of geographic information. This framework defines a high level model of the components required to handle semantics in the ISO geographic information standards with the use of ontologies.

2 Conformance

Any documents claiming conformance with this Technical Specification shall pass the requirements described in the abstract test suite presented in Annex A.

3 Normative references

The following documents, in whole or in part, are normatively referenced in this document and are indispensable for its application. For dated references, only the edition cited applies. For undated references, the latest edition of the referenced document (including any amendments) applies.

ISO/TS 19103:2005, *Geographic information — Conceptual schema language*

ISO 19109:2005, *Geographic information — Rules for application schema*

ISO 19119:2005, *Geographic information — Services*

ISO 19135:2005, *Geographic information — Procedures for item registration*

4 Terms and definitions

For the purpose of this document, the following terms and definitions apply.

4.1 application schema

conceptual schema (4.3) for *data* (4.4) required by one or more applications

[SOURCE: ISO 19101-1:—²], 4.1.2]

4.2 conceptual model

model that defines concepts of a universe of discourse

[SOURCE: ISO 19101-1:—³], 4.1.5]

2) To be published.

3) To be published.

4.3
conceptual schema

formal description of a *conceptual model* (4.2)

[SOURCE: ISO 19101-1:—⁴], 4.1.6]

4.4
data

reinterpretable representation of *information* (4.7) in a formalized manner suitable for communication, interpretation, or processing

[SOURCE: ISO/IEC 2382-1:1993, 01.01.02]

4.5
feature

abstraction of real world phenomena

[SOURCE: ISO 19101-1:—⁵], 4.1.11]

4.6
framework

logical structure for classifying and organizing complex *information* (4.7)

[SOURCE: ISO/TS 27790:2009, 3.27]

4.7
information

knowledge (4.8) concerning objects, such as facts, events, things, processes, or ideas, including concepts, that within a certain context has a particular meaning

[SOURCE: ISO 2382-1:1993, 01.01.01]

4.8
knowledge

cognizance which is based on reasoning

NOTE Adapted from ISO 5127:2001, 1.1.3.14.

4.9
metadata

data (4.4) about data

[SOURCE: ISO 19115:2003, 4.5]

4.10
ontology

formal representation of phenomena of a universe of discourse with an underlying vocabulary including definitions and axioms that make the intended meaning explicit and describe phenomena and their interrelationships

[SOURCE: ISO 19101-1:—⁶], 4.1.24]

4.11
registry

information (4.7) system on which a register is maintained

[SOURCE: ISO 19135:2005, 4.1.13]

4) To be published.

5) To be published.

6) To be published.

4.12
schema

formal description of a model

[SOURCE: ISO 19101-1:—⁷), 4.1.32]

4.13
Semantic Web

Web of *data* (4.4) with meaning

[SOURCE: ISO 19101-1:—⁸), 4.1.33]

NOTE The association of meaning allows data and *information* (4.7) to be understood and processed by automated tools as well as by people.

4.14
universe of discourse

view of the real or hypothetical world that includes everything of interest

[SOURCE: ISO 19101-1:—⁹), 4.1.36]

4.15
Uniform Resource Identifier (URI)

unique identifier for a resource, structured in conformance with IETF RFC 2396

[SOURCE: ISO 19136:2007, 4.1.65]

4.16
Web service

service that is made available through the Web

[SOURCE: ISO 19101-1:—¹⁰), 4.1.39]

NOTE A Web service usually includes some combination of programming and data. It may also include human resources.

5 Symbols and abbreviated terms

For the purpose of this Technical Specification, the following symbols and abbreviated terms apply.

HTTP	Hypertext Transfer Protocol
LCCS	Land Cover Classification System
LADM	Land Administration Domain Model
ODM	Ontology Definition Metamodel
OMG	Object Management Group
OWL	Web Ontology Language
OWL-DL	OWL - Description Logic
OWL-S	Semantic Markup for Web Services

7) To be published.

8) To be published.

9) To be published.

10) To be published.

PDF	Portable Document Format
RDF	Resource Description Framework
RDF-S	RDF Schema
RIF	Rule Interchange Format
SPARQL	Simple Protocol and RDF Query Language
UML	Unified Modelling Language
URI	Uniform Resource Identifier
W3C	World Wide Web Consortium
XML	eXtensible Markup Language
WSMO	Web Service Modelling Ontology

6 Ontology in geographic information

6.1 Introduction

Semantics has an essential role in the interoperability of geographic information. The background information to explain this is provided in Annex B. Ontology is a fundamental notion to support semantic interoperability of geographic information. Accordingly, this Technical Specification adheres to the information technology and artificial intelligence viewpoint for ontology. In agreement with this viewpoint and in the context of ISO geographic information standards, an ontology refers to a formal representation of phenomena with an underlying vocabulary including definitions and axioms that make the intended meaning explicit and describe phenomena and their interrelationships. An ontology can be used by software applications to support the sharing, reuse, and integration of geographic information with any other information sources within a domain of knowledge as well as between various domains of knowledge. It is represented by classes, relations, properties, attributes, and values. It constitutes a foundation to support reasoning, interpretation, and inference.

6.2 Values of ontologies

Ontology is a fundamental notion for semantic interoperability, for data available on the Semantic Web and as such for geographic information interoperability. The following values of ontology are recognized as important with respect to interoperability of geographic information:

- Interoperability across domains;
- Expose ISO geographic information standards to other communities that are not aware of the geographic information domain;
- Automatic machine reasoning and inference;
- From data description via information description to knowledge description;
- Focus on online access of information and knowledge (as opposed to offline access);
- Interrelate similar/different concepts (such as different keywords for similar concepts in metadata); and
- Associate (similar/different) concepts between domains.

6.3 Issues of relevance

Considering the values of ontologies for interoperability of geographic information, the following issues become relevant for the ISO geographic information standards:

- Developing rules for writing application ontologies for OWL;
- Introducing ontologies as part of product specification applications;
- Developing content standards in ontologies using OWL [42] (application ontologies, domain ontologies, metalanguages);
- Introducing spatial operators as defined in ISO 19107 [19] and ISO 19125-1 [21] to the Semantic Web for spatial reasoning and inference, so that they can be used as part of Semantic Web languages (RDF [39], RDF-S [38], and OWL [42]);
- Defining semantic operators about the semantic similarity with respect to concepts, definition and use as part of Semantic Web languages (RDF [39], RDF-S [38], and OWL [42]);
- Translation of the ISO harmonized model from UML to OWL; and
- Defining Web services ontologies.

7 Framework

7.1 Overview of the framework

The framework of this Technical Specification (Figure 1) presents the structure of the packages that are introduced to address semantics of geographic information through ontologies. The chosen ontology language is OWL-DL. This choice is justified because of the level of expressivity and the reasoning capabilities it provides.

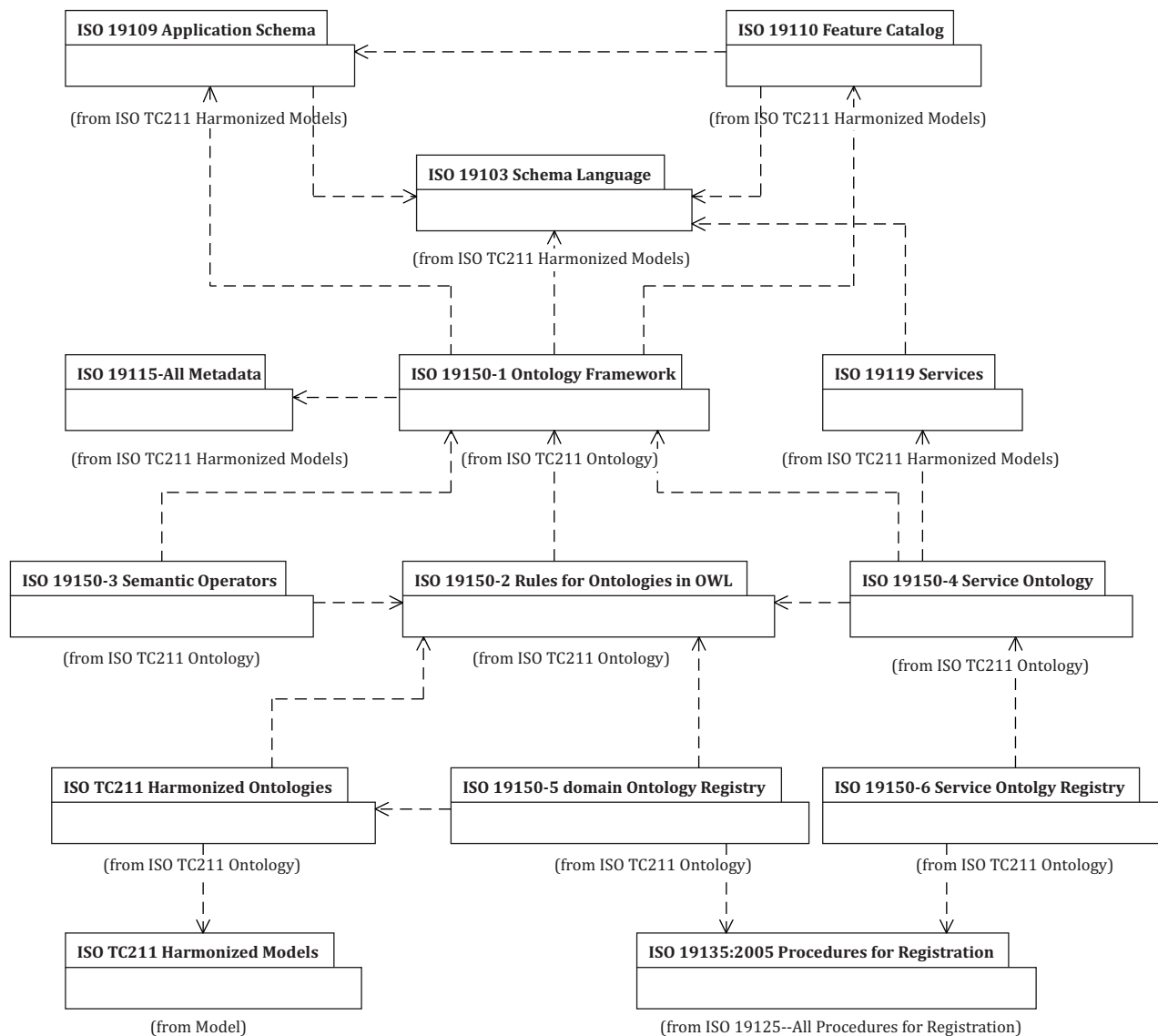

Figure 1 — Framework decomposition in packages and dependencies

The framework introduces seven components including this framework that have dependencies with other existing parts of the ISO geographic information standards¹¹⁾. These components are:

ISO/TS 19150-1, *Geographic information — Ontology — Part 1: Framework (i.e. this Technical Specification)*;

International Standard to be published:

ISO 19150-2, *Geographic information — Ontology — Part 2: Rules for developing ontologies in the Web Ontology Language (OWL)*.

International Standards under development:

ISO 19150-3, *Geographic information — Ontology — Part 3: Semantic operators*.

ISO 19150-4, *Geographic information — Ontology — Part 4: Service ontology*.

ISO 19150-5, *Geographic information — Ontology — Part 5: Domain ontology registry*.

11) Only geographic information standards that have direct dependencies with the introduced components are shown in the framework diagram.

ISO 19150-6, *Geographic information — Ontology — Part 6: Service ontology registry*.

“ISO TC211 *Harmonized Ontologies*”.

7.2 Rules for developing ontologies in the Web Ontology Language

Ontologies need to be consistent to simplify their use and interoperability. They shall be developed in harmonization with ISO/TS 19103 and ISO 19109. A methodology and rules for translating UML diagrams to OWL-DL ontologies are required. This can benefit from OMG’s Ontology Definition Metamodel (ODM) [32].

ISO 19150-2 shall define rules and guidelines for the development of ontologies to better support the interoperability of geographic information on the Semantic Web with OWL-DL. It shall also define a mapping of the UML class diagram elements used in the ISO geographic information standards into OWL-DL and rules for describing application schemas based on the General Feature Model (as defined in ISO 19109 in OWL-DL. Such rules shall address the following issues:

- Naming: ISO geographic information models use the same name in different context which is not allowed in ontologies, moreover in OWL-DL;
- The manner in which UML packages are addressed in ontologies;
- Abstract class;
- Stereotype;
- Aggregation and composition;
- Association names;
- Qualified associations;
- Enumerations and code lists;
- Operations and methods;
- Ontology quality assessment.

7.3 Semantic operators

Ontologies provide the definitions of concepts and the relationships between them with respect to some context. As such, reasoning and inference with ontologies is then possible. Annex C provides background information on ontology matching and semantic similarity for ontology reasoning in the geographic domain. Reasoning and inference can lead to a wide range of possibilities related to interoperability: data discovery, query answering, geographic data integration, and composition of geographic data with data from other sources and domains. It can be supported by the definition of semantic operators which complement ISO geographic information geometric and temporal operators.

ISO 19150-3 shall define semantic proximity operators between concepts associated with geometric and temporal representations. These operators complement the current suites of geometric and temporal operators already defined in ISO 19107 [19], ISO 19108 [18], ISO 19125-1 [21], and ISO 19141 [23].

7.4 Service ontology

Web services are important components that compose the Web. Currently, the use and interaction of Web services still require the participation of humans to find and integrate Web services. The Semantic Web could also contribute to facilitate the interaction with Web services by introducing semantics and ontologies for Web Services [37]. The Semantic Web can support Web services to automate the Web service discovery, the composition of Web services, and their invocation in order to enable seamless machine interoperation with minimum human interaction. Semantic annotation of services in terms of capabilities, selection, access, composition, and invocation are then required and should be supported through ontologies.

Two frameworks are found to support the above functionalities: Semantic Markup for Web Services (OWL-S) (Figure 2) [43] and Web Service Modelling Ontology (WSMO) (Figure 3) [34].

OWL-S is an ontology of services to support discovery, composition, and invocation of Web services. The structure of a service ontology has three parts: service profile, process model, and grounding. The service profile provides details about what the service can do for clients; the capabilities. The main task of the service profile is for advertising and discovering services. The service process model provides details about how the service operates. The grounding provides details about the way to interact with a service via messages, such as transport protocols.

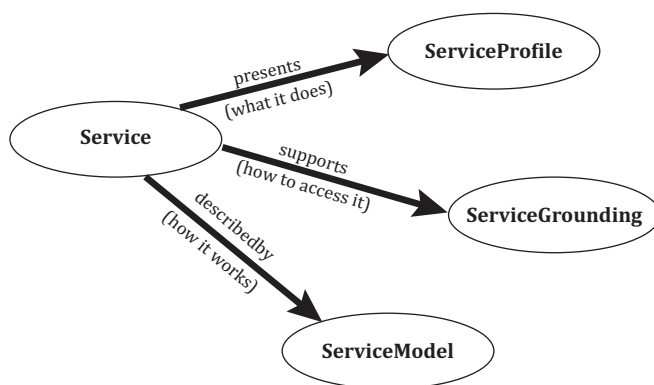

Figure 2 — OWL-S service ontology

WSMO has been developed for Web service from the European Semantic Systems Initiative. It is composed of four main elements: ontologies, Web services, goals, and mediators. The ontologies provide the formal specification of terminology used by the other WSMO components. The Web services provide the semantic description of Web services in terms of capabilities, interfaces, and internal operations of the service. Goals refer to the objectives that a client wants to achieve by using Web services. The mediators provide the connectors between components with mediation facilities for handling heterogeneities.

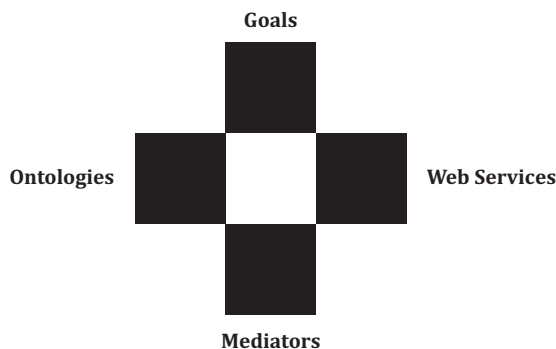

Figure 3 — WSMO components

OWL-S and WSMO have been submitted to W3C as potential input to future W3C recommendations. Other developments like WSMO Lite and Linked Open Services are also relevant to look at and to consider.

In the ISO geographic information standards, ISO 19119 sets the basis for developing geospatial services and for the documentation of these services through service metadata. This could be seen as a foundation for the definition of geospatial service ontology allowing semantic annotation.

ISO 19150-4 shall identify the appropriate framework for service ontology in geographic information (OWL-S or WSMO) and shall define the description of Web services for geographic information in an ontology language in order to be discovered on the Semantic Web.

7.5 Domain ontology registry

More attention is being given to the content part of geographic information in the ISO suite of geographic information standards (e.g. ISO 19144-2 [24] and ISO 19152 [25]). Other topics such as climate change variables and addressing are becoming of interest. Accordingly, a registry for geographic information ontology is required for semantic interoperability between domains.

ISO 19150-5 shall define an international registry of geographic information domain ontologies and its maintenance. The registry will be composed of standardized high level geographic information ontologies. These ontologies shall be developed in OWL-DL. They shall be posted on the Web to support Semantic Web applications. These ontologies shall be developed to serve as a basic framework for the definition of ontologies at finer level of granularity for application, shall allow mapping of concepts between application domain specific ontologies within a shared domain, and shall enable the interrelation of concepts across domains.

7.6 Service ontology registry

ISO 19150-6 shall define an international registry of geographic information service ontologies and its maintenance. The registry will be composed of standardized geographic information service ontologies. These ontologies shall be developed in compliance with ISO 19150-4 which prescribes the definition of service ontologies.

7.7 Harmonized ontologies

The “ISO TC211 Harmonized Ontologies” package shall consist of a set of OWL-DL ontologies corresponding to the ISO/TC 211 harmonized model. This package shall be posted on the Web to support Semantic Web applications.

7.8 Framework package dependencies

First, the framework (ISO/TS 19150-1) is dependent on ISO 19109, ISO 19110 [22], ISO 19115 [20], and ISO/TS 19103 parts that condition the abstraction of the geographic features and their representation into data. ISO 19109 defines the General Feature Model (GFM), which dictates how a universe of discourse is abstracted and defines the metamodel for the description of feature types with their properties and relationships between feature types. ISO 19110 [22] defines the methodology for feature cataloguing based on GFM for the documentation of the semantics of each feature type, its properties, relationships, and so on. In addition to the choice of a conceptual model, ISO/TS 19103 defines a number of data types to be used in conceptual models and ontologies for geographic data representation. Finally, ISO 19115 [20] defines some data types that have to be considered in the development of geographic ontologies.

Rules for developing ontologies in the Web Ontology Language (OWL), ISO 19150-2, ISO 19150-3, and ISO 19150-4 are subordinate to this framework. These packages shall agree to this framework. Additionally, ISO 19150-4 shall agree with ISO 19119 on the manner that services are described and can be discovered.

Then, the derivation of an “ISO TC211 Harmonized Ontologies” package (i.e. OWL-DL ontologies) shall be processed according to the rules set in ISO 19150-2 and, as such, the “ISO TC211 Harmonized Ontologies” package is dependent on ISO 19150-2. The “ISO TC211 Harmonized Ontologies” package is obviously dependent on the foundational ISO/TC 211 harmonized models (i.e. “ISO TC211 Harmonized Ontologies” package in Figure 1). The “ISO TC211 Harmonized Ontologies” package shall comply with the ISO/TC 211 harmonized models. The “ISO TC211 Harmonized Ontologies” package is complementary to the ISO/TC 211 harmonized model.

The domain ontologies registry ISO 19150-5 with the registered domain ontologies shall adhere to ISO 19150-2 and to the “ISO TC211 Harmonized Ontologies” and, as such, are dependent on them. ISO 19150-5 is also dependent on ISO 19135.

The service ontologies registry (ISO 19150-6 and the registered service ontologies) shall adhere to ISO 19150-4 and, as such, are dependent on it. ISO 19150-6 is also dependent on ISO 19135.

Annex A (normative)

Abstract test suite

A.1 Requirements

This Technical Specification identifies requirements for:

- Rules for developing ontologies in the Web Ontology Language (OWL);
- Semantic operators;
- Service ontology;
- Domain ontology registry;
- Service ontology registry;
- “ISO TC211 Harmonized Ontologies”;
- Framework package dependencies.

A.2 Rules for developing ontologies in the Web Ontology Language (OWL)

A.2.1 Rules and guidelines

The test for “Rules for developing ontologies in the Web Ontology Language (OWL)” is as follows:

- a) Test purpose: Verify that ISO 19150-2 defines rules and guidelines for the development of ontologies in OWL-DL that support interoperability of geographic information on the Semantic Web;
- b) Test method: Inspect if the scope of ISO 19150-2 identifies that it defines rules and guidelines for the development of ontologies in OWL-DL that support interoperability of geographic information on the Semantic Web;
- c) Reference: 7.2;
- d) Test type: Basic test.

A.2.2 Mapping between UML class diagram elements to OWL

The test for “Mapping between UML class diagram elements to OWL” is as follows:

- a) Test purpose: Verify that ISO 19150-2 defines a mapping of the UML class diagram elements used in ISO geographic information standards into OWL-DL and rules for describing application schemas based on the General Feature Model in OWL-DL.
- b) Test method: Inspect if ISO 19150-2 sets rules to map UML class diagram elements used in ISO geographic information standards into OWL-DL and sets rules for describing application schemas based on the General Feature Model in OWL-DL. Inspect if the rules address the following issues:
 - Naming;
 - UML packages;

- Abstract class;
 - Stereotype;
 - Aggregation and composition;
 - Association names;
 - Qualified associations;
 - Enumerations and code lists;
 - Operations and methods;
 - Ontology quality assessment.
- c) Reference: 7.2;
- d) Test type: Capability test.

A.2.3 Dependency with this Technical Specification framework

The test for “Dependency with this Technical Specification framework” is as follows:

- a) Test purpose: Verify that ISO 19150-2 agrees with this Technical Specification framework;
- b) Test method: Inspect if ISO 19150-2 sets its dependency with this Technical Specification framework;
- c) Reference: 7.8;
- d) Test type: Capability test.

A.3 Semantic operators

A.3.1 Semantic operator definition

The test for “Semantic operator definition” is as follows:

- a) Test purpose: Verify that ISO 19150-3 defines semantic proximity operators between concepts associated with geometric and temporal representations;
- b) Test method: Inspect if the scope of ISO 19150-3 identifies that it defines semantic proximity operators between concepts associated with geometric and temporal representations;
- c) Reference: 7.3;
- d) Test type: Basic test.

A.3.2 Dependency with this Technical Specification framework

The test for “Dependency with this Technical Specification framework” is as follows:

- a) Test purpose: Verify that ISO 19150-3 agrees with this Technical Specification framework;
- b) Test method: Inspect if ISO 19150-3 sets its dependency with this Technical Specification framework;
- c) Reference: 7.8;
- d) Test type: Capability test.

A.4 Service ontology

A.4.1 Description of Web services

The test for “Description of Web services” is as follows:

- a) Test purpose: Verify that ISO 19150-4 defines the description of Web services for geographic information in an ontology language in order to be discovered on the Semantic Web;
- b) Test method: Inspect if the scope of ISO 19150-4 identifies that it defines the description of Web services for geographic information in an ontology language in order to be discovered on the Semantic Web;
- c) Reference: 7.4;
- d) Test type: Basic test.

A.4.2 Framework for service ontology

The test for “Framework for service ontology” is as follows:

- a) Test purpose: Verify that ISO 19150-4 identifies the appropriate framework for service ontology in geographic information;
- b) Test method: Inspect if ISO 19150-4 sets which framework of service ontologies shall be used for the description of Web services for geographic information;
- c) Reference: 7.4;
- d) Test type: Basic test.

A.4.3 Dependency with this Technical Specification framework

The test for “Dependency with this Technical Specification framework” is as follows:

- a) Test purpose: Verify that ISO 19150-4 agrees with this Technical Specification framework;
- b) Test method: Inspect if ISO 19150-4 sets its dependency with this Technical Specification framework;
- c) Reference: 7.8;
- d) Test type: Capability test.

A.4.4 Dependency with ISO 19119

The test for “Dependency with ISO 19119” is as follows:

- a) Test purpose: Verify that ISO 19150-4 agrees with ISO 19119;
- b) Test method: Inspect if ISO 19150-4 sets its dependency with ISO 19119;
- c) Reference: 7.8;
- d) Test type: Capability test.

A.5 Domain ontology registry

A.5.1 International registry of geographic information domain ontologies

The test for “International registry of geographic information domain ontologies” is as follows:

- a) Test purpose: Verify that ISO 19150-5 defines an international registry of geographic information domain ontologies and its maintenance;
- b) Test method: Inspect if the scope of ISO 19150-5 identifies that it defines an international registry of geographic information domain ontologies and its maintenance;
- c) Reference: 7.5;
- d) Test type: Basic test.

A.5.2 Ontology language

The test for “Ontology language” is as follows:

- a) Test purpose: Verify that ISO 19150-5 ensures that ontologies of the registry are developed in OWL-DL;
- b) Test method: Inspect if ISO 19150-5 requires that the ontology language is OWL-DL;
- c) Reference: 7.5;
- d) Test type: Basic test.

A.5.3 Concept mapping

The test for “Concept mapping” is as follows:

- a) Test purpose: Verify that ISO 19150-5 ensures that the ontology registry enables mapping of concepts between application specific ontologies within a shared domain and to interrelate concepts across domains;
- b) Test method: Inspect if ISO 19150-5 defines and provides functionalities to map concepts between application specific ontologies and to interrelate concepts across domains;
- c) Reference: 7.5;
- d) Test type: Basic test.

A.5.4 Dependency with ISO 19150-2

The test for “Dependency with ISO 19150-2” is as follows:

- a) Test purpose: Verify that ontologies of the “Domain ontology registry” agree with the rules set in ISO 19150-2;
- b) Test method: Inspect if ontologies of the “Domain ontology registry” pass the tests of ISO 19150-2 abstract test suite about rules for application schema;
- c) Reference: 7.8;
- d) Test type: Capability test.

A.5.5 Dependency with ISO 19135

The test for “Dependency with ISO 19135” is as follows:

- a) Test purpose: Verify that the “Service ontology registry” agrees with the requirements set in ISO 19135;

- b) Test method: Inspect if the “Service ontology registry” passes the tests of ISO 19135 abstract test suite;
- c) Reference: 7.8;
- d) Test type: Capability test.

A.6 Service ontology registry

A.6.1 International registry of geographic information service ontologies

The test for “International registry of geographic information service ontologies” is as follows:

- a) Test purpose: Verify that ISO 19150-6 defines an international registry of geographic information service ontologies and its maintenance;
- b) Test method: Inspect if the scope of ISO 19150-6 identifies that it defines an international registry of geographic information domain ontologies and its maintenance;
- c) Reference: 7.6;
- d) Test type: Basic test.

A.6.2 Service ontologies

The test for “Service ontologies” is as follows:

- a) Test purpose: Verify that the service ontologies of the international registry of geographic information service ontologies comply with ISO 19150-4;
- b) Test method: Inspect if ISO 19150-6 service ontology complies with ISO 19150-4;
- c) Reference: 7.6;
- d) Test type: Basic test.

A.6.3 Dependency with ISO 19150-4

The test for “Dependency with ISO 19150-4” is as follows:

- a) Test purpose: Verify that service ontologies of the “Service ontology registry” agrees with the requirements set in ISO 19150-4;
- b) Test method: Inspect if service ontologies of the “Service ontology registry” pass the tests of ISO 19150-4 abstract test suite;
- c) Reference: 7.8;
- d) Test type: Capability test.

A.6.4 Dependency with ISO 19135

The test for “Dependency with ISO 19135” is as follows:

- a) Test purpose: Verify that the “Service ontology registry” agrees with the requirements set in ISO 19135;
- b) Test method: Inspect if the “Service ontology registry” passes the tests of ISO 19135 abstract test suite;
- c) Reference: 7.8;
- d) Test type: Capability test.

A.7 ISO/TC 211 Harmonized ontologies

A.7.1 “ISO/TC211 Harmonized Ontologies” package

The test for “ISO/TC 211 Harmonized Ontologies” is as follows:

- a) Test purpose: Verify that the “ISO TC211 Harmonized Ontologies” package defines OWL-DL ontologies corresponding to the ISO/TC 211 Harmonized model;
- b) Test method: Inspect if the “ISO TC211 Harmonized Ontologies” describes all components of the ISO/TC 211 Harmonized model in OWL-DL;
- c) Reference: 7.7 and 7.8;
- d) Test type: Capability test.

A.7.2 Ontologies on the Web

The test for “Ontologies on the Web” is as follows:

- a) Test purpose: Verify that the “ISO TC211 Harmonized Ontologies” are posted on the Web;
- b) Test method: Inspect if the “ISO TC211 Harmonized Ontologies” are published on the Web;
- c) Reference: 7.7;
- d) Test type: Basic test.

A.7.3 Dependency with ISO 19150-2

The test for “Dependency with ISO 19150-2” is as follows:

- a) Test purpose: Verify that the “ISO TC211 Harmonized Ontologies” are processed in agreement with the rules set in ISO 19150-2;
- b) Test method: Inspect if the “ISO TC211 Harmonized Ontologies” pass the tests of ISO 19150-2 abstract test suite about rules for derivation of OWL-DL ontologies from UML class diagram elements;
- c) Reference: 7.8;
- d) Test type: Capability test.

Annex B (informative)

Background information on ontologies

B.1 Description of semantics

Semantics refers to the study of meanings. It has been studied in numerous disciplines such as philosophy, psychology, semiotics, cybernetics, and applied linguistics. Semantics deals with establishing the relationship between real world objects and data. It has been described deeply by many authors using the meaning triangle [7] [9] shown in Figure B.1 where the relation between a phenomenon and a sign (or the data) used for its representation is indirect. The relation between a phenomenon and the signs designating it is given by the way of concepts that are maintained in knowledge bases, e.g. the mind of human beings, conceptual models, or ontologies in computer systems. This triangle is essentially a description of how semantics is understood in the fields of semiotics, cybernetics, and applied linguistics.

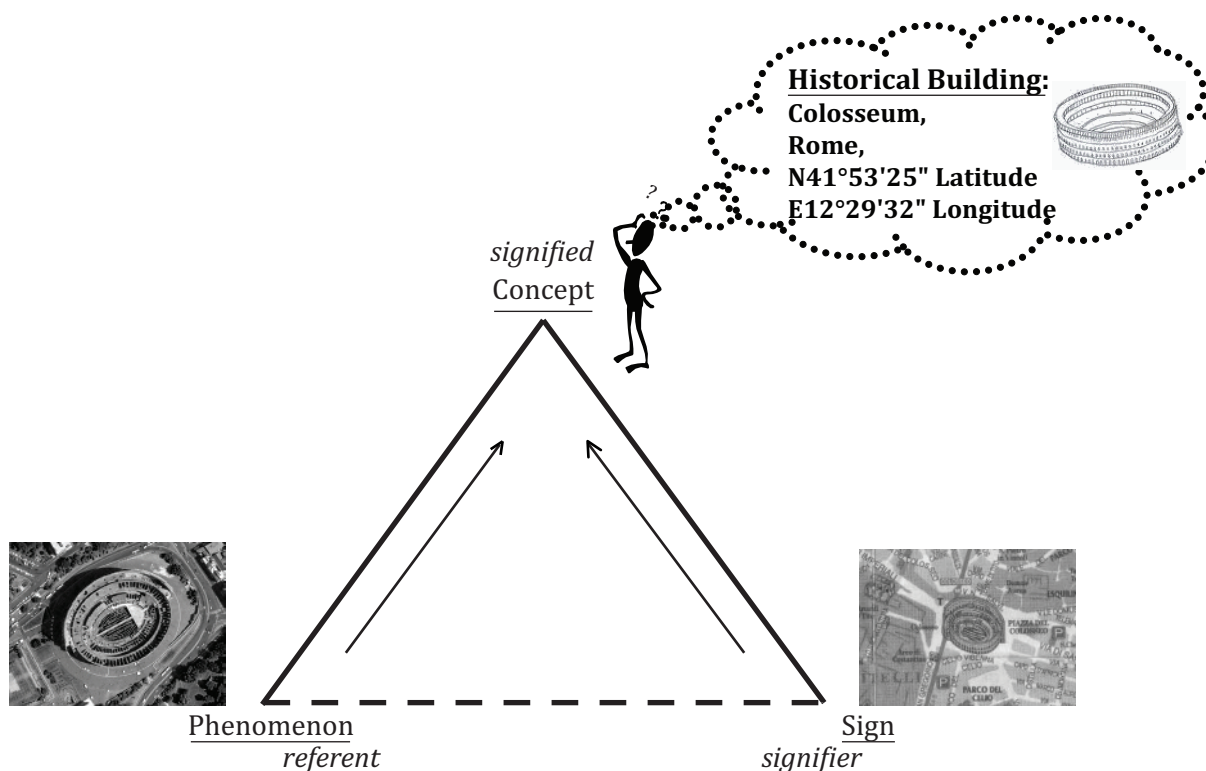

Figure B.1 — Semantic triangle: Phenomenon - Concept - Sign

B.2 ISO geographic information standards related works

The ISO geographic information standards have an important record of standards and technical specifications that relate to semantics. They define numerous concepts that set the semantics for data describing real world phenomena. They address terminology, rules and methodologies for

content description, schemas, encoding. The list below identifies a subset of standards and technical specifications that contributes to the semantic definition of geographic information concepts.

- Terminology
 - ISO/TS 19104, *Geographic information — Terminology*
 - ISO/TS 19138, *Geographic information — Data quality measures*
- Rules and methodologies for content description
 - ISO 19109, *Geographic information — Rules for application schema*
 - ISO 19110, *Geographic information — Methodology for feature cataloguing*
 - ISO 19126, *Geographic information — Feature concept dictionaries and registers*
 - ISO/TS 19127, *Geographic information — Geodetic codes and parameters*
 - ISO 19131, *Geographic information — Data product specifications*
 - ISO 19135, *Geographic information — Procedures for item registration*
 - ISO 19144-1, *Geographic information — Classification systems — Part 1: Classification system structure*
 - ISO 19145, *Geographic information — Registry of representations of geographic point location¹²⁾*
 - ISO 19146, *Geographic information — Cross-domain vocabularies*
- Schemas
 - ISO/TS 19103, *Geographic information — Conceptual schema language*
 - ISO 19107, *Geographic information — Spatial schema*
 - ISO 19108, *Geographic information — Temporal schema*
 - ISO 19111, *Geographic information — Spatial referencing by coordinates*
 - ISO 19111-2, *Geographic information — Spatial referencing by coordinates — Part 2: Extension for parametric values*
 - ISO 19112, *Geographic information — Spatial referencing by geographic identifiers*
 - ISO 19115, *Geographic information — Metadata*
 - ISO 19115-2, *Geographic information — Metadata — Part 2: Extensions for imagery and gridded data*
 - ISO 19119, *Geographic information — Services*
 - ISO 19123, *Geographic information — Schema for coverage geometry and functions*
 - ISO 19125-1, *Geographic information — Simple feature access — Part 1: Common architecture*
- Content description
 - ISO 19144-2, *Geographic information - Classification systems — Part 2: Land Cover Meta Language (LCML)*

12) To be published.

- ISO 19152, *Geographic information — Land Administration Domain Model (LADM)*¹³⁾
- Location-based services
 - ISO 19133, *Geographic information — Location-based services — Tracking and navigation*
 - ISO 19134, *Geographic information — Location-based services — Multimodal routing and navigation*
 - ISO 19141, *Geographic information — Schema for moving features*
- Common format (Encoding)
 - ISO 19118, *Geographic information — Encoding*
 - ISO 19136, *Geographic information — Geography Markup Language (GML)*
 - ISO/TS 19139, *Geographic information — Metadata — XML schema implementation*

B.3 The Semantic Web

B.3.1 Introduction

Since its inception, the Web has consisted of a system of linked documents that are available in an open or well known distribution format such as hypertext format or portable document format (PDF). Web documents relate to each other using hyperlinks or other predefined fixed links¹⁴⁾. They may contain texts, images, sounds, videos, and other multimedia documents and may be viewed using a Web browser and plug-ins. Web documents are essentially intended for human beings, which have to figure out the very nature and usefulness of their content for their purpose. Initially, the Web and Web documents were not designed to be used or interpreted by software or machines. Search engines facilitate document discovery on the Web based on keyword indexing.

The Semantic Web is an extension of the current Web that consists of a Web of data and information that are processable by computers [3]. It is able to answer questions involving semantics as opposed to just returning Web pages or documents on specific topics based on keyword search. The Semantic Web is application independent, composable, classified, and part of a large information structure. Since data are understandable and processable by machines, they need to be much more clever than current Web documents.

The Semantic Web provides a solution for:

- information overload and especially with the propagation of the Internet;
- locating and retrieving data on the Web complying with users' needs;
- breaking stovepipe systems and allowing information sharing;
- integrating and aggregating data from various sources on the Web; and
- enabling users to retrieve data efficiently.

The Semantic Web deals with common formats. Accordingly, the syntactic foundation of the Semantic Web is the eXtensible Markup Language (XML) [40]. Based on XML, languages such as Resource Description Framework (RDF) [37], RDF Schema (RDF-S) [38], and Web Ontology Language (OWL) [42] are used for data and concept representation whereas Simple Protocol and RDF Query Language (SPARQL) [41] is used for query.

13) To be published.

14) Public access information systems (with graphics) have been available over world wide data networks since the late 1970's but the defining characteristics of the World Wide Web since the early 1990's has been the indirect addressing system of web addresses based on registered domain names.

In the Semantic Web, data make up the raw level of the knowledge continuum (Figure B.2). They consist of bits, bytes, characters, etc. The syntax refers to the structure in which the data are described. The syntax helps to identify the different pieces of data which are essential to enable their further processing by computers and software. Once pieces of data are recognized, semantics is necessary to interpret what they mean. For example, `<gmd:CI_Date>` has a specific meaning in the context of geospatial metadata; it means a date that could be of creation, publication, or revision. In a data set citation context, it can tell when this data set was revised, for example, *Data set A* as illustrated in Figure B.2 was revised on 2004-08-12 and *Data set B* was revised on 2006-05-22. Finally, through integration, combination, and reasoning with multiple information, users can derive additional information such as *Data set B* is more recent than *Data set A*, that is derived knowledge.

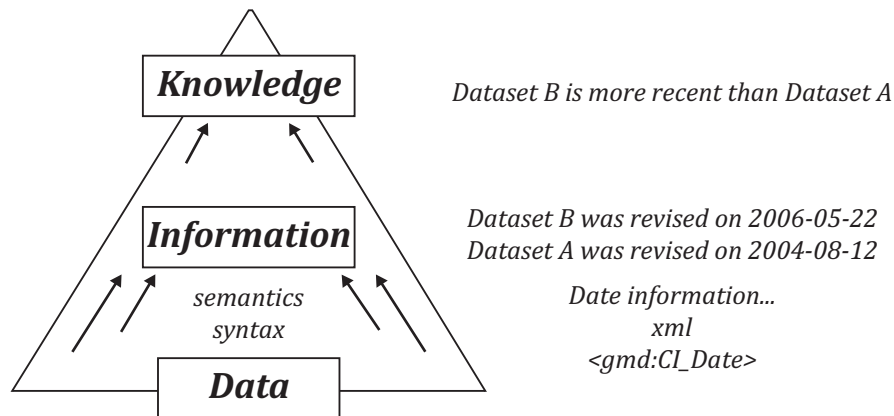

Figure B.2 — Knowledge continuum

Web services also take advantage of the Semantic Web. More recently, Web services have brought additional functionalities on the Web by introducing distributed software resources conforming to Web standards. However, these services, each providing specific functionalities, also need to be discovered and their uses are often limited to groups of experts or a particular user community. The description of Web services with ontologies (i.e. semantic annotation) can facilitate their discovery, invocation, interaction, and composition to enhance interoperability of Web services. Web services are important components of the Semantic Web since the Semantic Web is for data understandable and processable by machines, which may also be Web services. Web services and Semantic Web are well harmonized since they both adhere to common principles: URI, XML, and data.

At least five elements are needed to enable the Semantic Web:

- logical assertions;
- classification of concepts;
- formal models;
- rules;
- trust.

First, the Semantic Web requires logical assertions to associate a subject to an object with a verb. For example, the author of the map 44071-A1-TM-100 is the US Geological Survey. Second, classification of concepts such as taxonomies and ontologies is required to define vocabularies. Third, formal models are essential to define concepts, their properties, and relationships between concepts, which are fundamental for reasoning. Fourth, rules are necessary for the derivation of conclusions by inference. Fifth, trust is deemed necessary in order to provide access to Semantic Web resources only to trusted agents. For instance, an agent can be asserted “trusted” from another via a digital signature.

B.3.2 Ontology in Semantic Web

B.3.2.1 Introduction

Ontology is a fundamental notion in the Semantic Web. An ontology defines the meaning of data and describes it in a format that machines and applications can read. As such, an application using data also has access to their inherent semantics through the ontology associated with it. Ontologies can support integration of heterogeneous data captured by different communities by relating them based on their semantic similarity, although it cannot solve it on their own. The notion of ontology is explained further in B.5.

Current World Wide Web Consortium (W3C) technologies supporting the Semantic Web are:

- RDF;
- RDF-S;
- OWL.

B.3.2.2 RDF

RDF is an XML-based language that represents information about specific resources or things that are found on the Web. Information is represented as a triple: *Subject*, *Predicate* and *Object* (Figure B.3). The *Subject* is the resource or the thing about which something is asserted. The *Predicate* is the relation that binds the *Subject* to the *Object*. The *Object* is either a literal value describing the *Subject* or another resource referred to the *Subject* by the predicate.

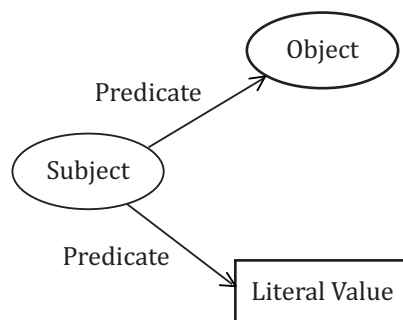

Figure B.3 — The Subject, Predicate and Object triple

To continue our example in Figure B.1, an RDF description of the location of the Colosseum in Rome may be presented as follows:

```
< rdf:Description rdf:about = "#Colosseum" >  
  < ex:isLocatedIn >  
    < rdf:Description rdf:about = "#Rome"/ >  
  < /ex:isLocatedIn >  
< /rdf:Description >
```

Where:

#Colosseum is a Web resource corresponding to the subject;

isLocatedIn is the predicate;

#Rome is another Web resource corresponding to the object.

Since the Semantic Web is based on URIs, any resource or thing would typically be identified by an URI.

B.3.2.3 RDF-S

RDF-S provides definitions of classes and properties that are required for the description of classes, properties and other resources. It is based on RDF. These RDF resources support the creation of application or user community specific RDF vocabularies and thus creating classes for specific data. Class instances can then be defined in RDF. RDF-S introduces relations between classes and instances as property.

Figure B.4 illustrates an example using RDF-S language for the definition of the classes *ISO19115*, *CitationAndResponsibleParty*, and *CI_Address* where *CI_Address* is a subclass of *CitationAndResponsibleParty*. The example also shows the definition of the property *addressAdministrativeArea* that is of the type *&rdfs;Literal* and is associated to *CI_Address*.

```
<?xml version='1.0' encoding='UTF-8'?>
<!DOCTYPE rdf:RDF [
  <!ENTITY rdf 'http://www.w3.org/1999/02/22-rdf-syntax-ns#'>
  <!ENTITY rdf_ 'http://protege.stanford.edu/rdf'>
  <!ENTITY rdfs 'http://www.w3.org/2000/01/rdf-schema#'>
]>
<rdf:RDF xmlns:rdf="&rdf;"
  xmlns:rdf_="&rdf_;"
  xmlns:rdfs="&rdfs;">
  <rdfs:Class rdf:about="&rdf_;CI_Address"
    rdfs:label="CI_Address">
    <rdfs:subClassOf rdf:resource="&rdf_;CitationAndResponsibleParty"/>
  </rdfs:Class>
  <rdfs:Class rdf:about="&rdf_;CitationAndResponsibleParty"
    rdfs:label="CitationAndResponsibleParty">
    <rdfs:subClassOf rdf:resource="&rdf_ISO19115"/>
  </rdfs:Class>
  <rdfs:Class rdf:about="&rdf_;ISO19115"
    rdfs:label="ISO19115">
    <rdfs:subClassOf rdf:resource="&rdfs;Resource"/>
  </rdfs:Class>
  <rdf:Property rdf:about="&rdf_;addressAdministrativeArea"
    rdfs:label="addressAdministrativeArea">
    <rdfs:domain rdf:resource="&rdf_;CI_Address"/>
    <rdfs:range rdf:resource="&rdfs;Literal"/>
  </rdf:Property>
```

Figure B.4 — An ISO 19115, RDF-S example

B.3.2.4 OWL

OWL is a fundamental piece of the Semantic Web. It is based on RDF and RDF-S. OWL allows a more expressive description of classes and properties with additional relationships between classes and properties compared to RDF-S, which is applicable for the description of simple ontologies. It is based on formal logic which permits logical reasoning on the knowledge it supports. There are a number of profiles of OWL, each one introducing a different level of expressivity:

- 1) OWL 1 Lite: least level of expressivity, intended mainly for the description of classification hierarchy, cardinality constraints are limited to 0 or 1, provides decidable functionalities and reasoning capabilities, is considered a profile of OWL 2;
- 2) OWL 1 DL: stands for description logic, provides maximum expressivity without the loss of decidable functionalities and reasoning capabilities, adds knowledge representation to OWL-Lite that improves reasoning, allows much flexibility on cardinality restrictions, is considered a profile of OWL 2;

- 3) OWL 1 Full: allows maximum expressivity and the syntactic freedom of RDF. As such a class may be either a collection of individuals or an individual in itself. However, it is undecidable and cannot be used for reasoning;
- 4) OWL 2 EL: intended for ontologies of very large number of classes and properties, is a limited subset of OWL 2 features, basic reasoning can be performed in time that is polynomial with respect to the size of the ontology;
- 5) OWL 2 QL: intended for ontologies of very large amounts of instances of data and allows conjunctive queries;
- 6) OWL 2 RL: intended for applications requiring scalable reasoning without sacrificing much of the expressive power (designed mainly for rule-based reasoning engines);
- 7) OWL 2 DL: extend OWL 1 DL with additional features such as type separation, disjoint classes, role characteristics, inverse roles, role chains, qualified cardinality restrictions, self construct, negative assertion, and XML schema datatypes;
- 8) OWL 2 Full: union of OWL 2 DL and RDF-S, has a similar role as OWL 1 Full.

Figures B.5 and B.6 show the correspondances between the different profiles in terms of ontologies as well as in terms of languages.

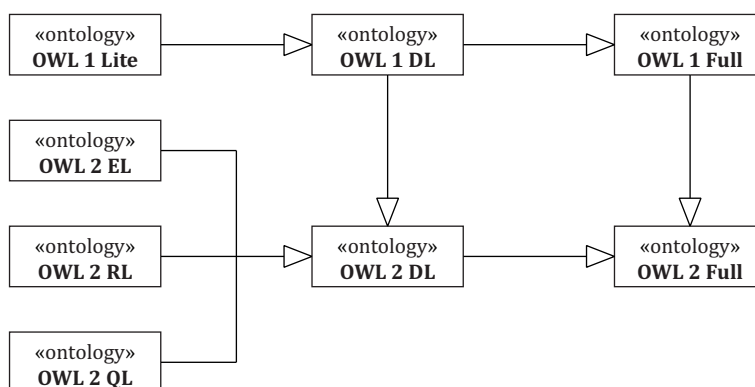

Figure B.5 — Correspondences between ontologies complying to different OWL profiles

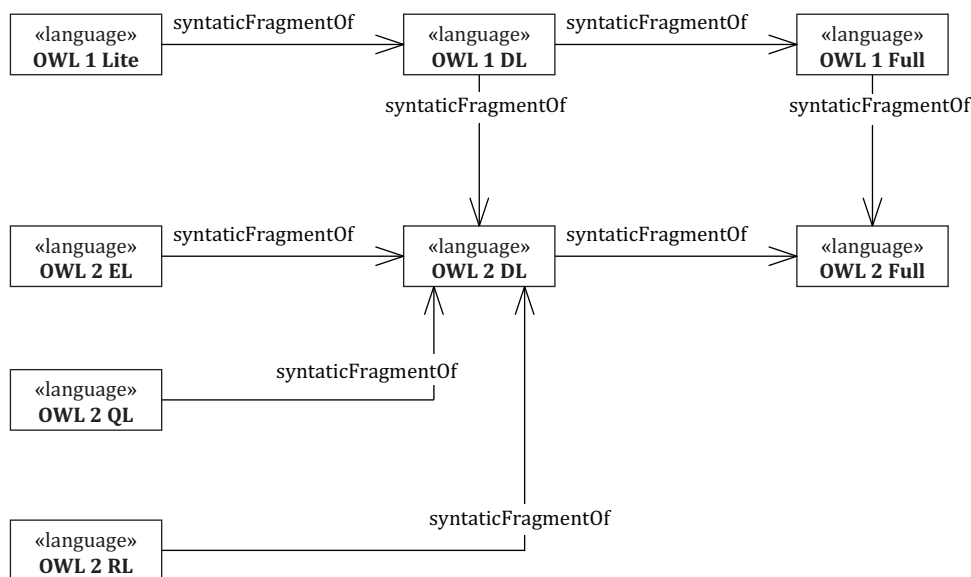

Figure B.6 — Correspondences between OWL language profiles

Figure B.7 illustrates the same ISO 19115 example as in Figure B.4 using OWL for the definition of the classes *ISO19115*, *CitationAndResponsibleParty*, and *CI_Address*.

```
<?xml version="1.0"?>
<rdf:RDF
  xmlns:rdf="http://www.w3.org/1999/02/22-rdf-syntax-ns#"
  xmlns:xsd="http://www.w3.org/2001/XMLSchema#"
  xmlns:rdfs="http://www.w3.org/2001/01/rdf-schema#"
  xmlns:owl="http://www.w3.org/2002/07/owl#"
  xmlns="http://www.owl-ontologies.com/unnamed.owl#"
  xml:base="http://www.owl-ontologies.com/unnamed.owl"
  <owl:Ontology rdf:about=""/>
  <owl:Class rdf:ID="ISO19115"/>
  <owl:Class rdf:about="#CitationAndResponsibleParty">
    <rdfs:subClassOf rdf:resource="#ISO19115"/>
  </owl:Class>
  <owl:Class rdf:ID="CI_Address">
    <rdfs:subClassOf>
      <owl:Class rdf:ID="CitationAndResponsibleParty"/>
    </rdfs:subClassOf>
  </owl:Class>
  <owl:Class rdf:about="#CitationAndResponsibleParty">
    <rdfs:subClassOf rdf:resource="#ISO19115"/>
  </owl:Class>
  <owl:DatatypeProperty rdf:ID="addressAdministrativeArea">
    <rdfs:range rdf:resource="http://www.w3.org/2001/XMLSchema#string"/>
    <rdfs:domain>
      <owl:Class>
        <owl:unionOf rdf:parseType="Collection">
          <rdf:Description rdf:about="http://www.w3.org/2002/07/owl#Thing"/>
          <owl:Class rdf:about="#CI_Address"/>
        </owl:unionOf>
      </owl:Class>
    </rdfs:domain>
  </owl:DatatypeProperty>
```

Figure B.7 — An ISO 19115 OWL example

B.3.3 Description logics

Description logics refer to knowledge representation formalisms used for the definition of the knowledge of an application domain. It can be used for defining the concepts in a domain as well as the properties of objects and individuals of that domain. Description logics set the philosophical and mathematical foundations for the knowledge representation. There are various description logics that have been defined: *ALL*, *SHOIN^(D)*, *SROIQ^(D)*. Some of them includes and extends on others; this is the case for *SHOIN^(D)* which includes and extends *ALL*. Description logics are useful because they are a good trade off for expressivity and scalability. They are also typically decidable and reasoning from it is possible.

The purpose here is not to provide an exhaustive description of description logics. This can be found on the Web (e.g. [Description Logics](#) [31]) and text books (e.g. The Description Logic Handbook [1]). The main purpose is to mention that description logics is the foundation for most of the OWL levels of expressivity (Table B.1).

Table B.1 — Correspondence between OWL levels of expressivity and description logics

Profile	OWL	OWL 2
Full	is not	is not
DL	<i>SHOIN</i> ^(D)	<i>SROIQ</i> ^(D)
Lite	<i>SHIF</i> ^(D)	<i>SHIF</i> ^(D)
EL	n/a	<i>EL++</i>
QL	n/a	DL-Lite
RL	n/a	DLP

B.3.4 Linked Data

Linked Data are an approach that aims at contributing to the development of the Web of data. As opposed to developing data in silos and duplicating data of various topics for their integration, Linked Data are oriented towards connecting data of different sources, subjects, and repositories via the Web. As a result, this eliminates duplication of data and, when data that are linked to others are updated, the updates are then available to all at the same time. Linked Data are a large scale integration of data over the Web that allows reasoning and making inferences taking into consideration multiple aspects. As a consequence, Linked Data implies publishing data on the Web in a way that it is machine-readable. This means that data shall follow a common model and format, i.e. RDF. Additionally, to understand what data mean and to reason with it, it is essential that the meaning of data are explicitly defined as well as machine readable. This is possible by way of ontology and languages such as OWL.

Linked Data are achieved through the use of the principles and the technologies of the Semantic Web described previously. Essentially, it consists of a set of principles and technologies connected to the Web infrastructure for the sharing and reuse of data over the Web. There are four principles underlying the concept of “Linked Data” [2]. The first principle requires using URI to identify real world objects and abstract concepts. The second principle prescribes the use of http:// URI so that data elements can be accessed by dereferencing the URI over the http protocol. As a result, objects and abstract concepts become Web resources. The third principle says that information shall be supplied against a given URI. The format shall be RDF, and SPARQL query services shall also return the data in RDF. The provided information is typically associated to ontologies (e.g. OWL) through URI to describe its meaning. The fourth principle asks for including URIs to external resources so that one can discover more about something just by following the connections.

Overall, Linked Data defines a methodology to interlink data through Web mechanisms and to publish them over the Web. However, links between data are created and maintained by data developers.

B.4 The Geospatial Semantic Web

The purpose of the Geospatial Semantic Web [10] [13] is to push the development of the Semantic Web in order to enhance the interoperability of geographic information on the Web. It also enables automated knowledge inference, which significantly increases the amount of geographic information. Additionally, the Geospatial Semantic Web may allow the interoperability of information across all data sources on the Web by relating geographic and non-geographic information and providing more interaction between the different data sources on the Web. As documented in [10] [13] [30], challenges identified relating to the Geospatial Semantic Web are:

- ontologies of spatial concepts used across disciplines;
- geospatial-relations ontology;
- geospatial feature ontology;
- place names ontology;
- ontology for metadata;

- ontology for coordinate reference systems;
- ontology management: designing, developing, storing, registering, discovering, browsing, maintaining and querying;
- canonical form for geospatial data queries;
- matching concepts to ontologies;
- ontology integration;
- ontological description/annotation of geo enabled Web Services.

B.5 Ontology

In philosophy, ontology refers to the description of the world in itself [33]; a model and an abstract theory of the world [35]; a systematic explanation of being [14]; the science of being, of the type of entities, of properties, of categories, and relationships that are part of the reality [4] [29]. It is understood in philosophy that there is only one ontology.

The term “ontology” has been borrowed by the information technology and artificial intelligence communities and typically refers to “an explicit specification of a conceptualisation” [15] and a “logical theory accounting for the intended meaning of a formal vocabulary” [16]. Other definitions can be found in [14] [34]. Information technology and artificial intelligence consider that reality may be abstracted differently depending on the context from which “things” are perceived and, as such, recognize that multiple ontologies about the same part of reality may exist. In agreement with these definitions and in the context of ISO geographic information standardization, an ontology refers to a formal representation of phenomena of a universe of discourse with an underlying vocabulary including definitions and axioms that make the intended meaning explicit and describe phenomena and their interrelationships.

There are several ways to formalize an ontology from weak to strong semantics: relational model, thesaurus, conceptual model, Unified Modelling Language (UML), OWL, description logic, first order logic, etc. [8] [26]. The ISO geographic information standards have adopted UML class diagrams to formalize classes, properties, and relations for the description of geographic information. UML is an object oriented formalism that was defined mainly for the design and development of systems, software, and database specifications. It can also be used for the specification of taxonomies, classifications, and description of concepts as in the ISO geographic information standards. Consequently, the ISO geographic information standards UML models can be considered ontologies even if they were not intended as such explicitly. Although it supports the development of software in programming in some languages, UML was not meant to be machine processable in a generic manner nor to support the definition of concepts processable on the Web and more specifically on the Semantic Web.

Ontologies may be developed at different levels. At least three levels are widely recognized: global or top-level, domain, and application ontology (Figure B.8) [6] [16]. A global or top-level ontology defines general concepts that are independent from a specific domain, for instance the concept of space or time. A domain ontology defines concepts that are specific to a body of knowledge (e.g. geographic information, transportation, geology, land cover). An application ontology defines concepts that are specialized within a given context or a specific usage (e.g. parcel delivery, ambulance dispatching, and rescue). Level of ontologies are related in a way that it is possible to navigate between ontologies of the same level as well as from application to domain and then global ontologies, and conversely.

Application schema and feature catalogues are the mechanisms defined by the ISO geographic information standards to support the description of semantics of geographic information. This level of description compares to the application ontology level. However to support interoperability across applications, higher ontology levels are required to enable the association of concepts across applications and domains.

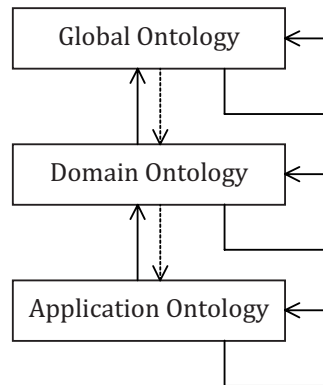

Figure B.8 — Levels of ontologies

B.6 Context

Context is an essential notion in semantic interoperability and reasoning. It provides concepts with real-world semantics. It guides how phenomena are perceived and abstracted, and then influences their definition in terms of concepts. It is essential to take into consideration the context in reasoning, for instance when resolving the semantic heterogeneity and similarity between concepts. As such, ontologies play an essential role as they maintain concepts and their associated meaning in various classes, properties (thematic, spatial, temporal), and relationships within a given context. Context provides details on:

- Use: user ID, user profile, user location, type of uses;
- Data: source, geospatial entities, meaning, scale, date of validity, etc.;
- Association: relationships (spatial, semantic, etc.);
- Procedure: process steps to capture the data, query to get the data, etc.

Metadata constitutes a valuable source of contextual details.

B.7 Semantic reference system

More recently, the notion of semantic reference system was introduced [27] [28]. A semantic reference system can be described as a framework providing functionalities to reference signs to concept specifications, to base concept specifications on real world phenomena, to enable the projection of concepts from one semantic space to another, and to allow the transformation between semantic reference systems. The ISO/TC 211 foundational element of its semantic reference system is the general feature model (GFM) (ISO 19109) that sets how geographic concepts are abstracted and specified. The specification of geographic concepts is supported by a set of concepts defined within the ISO geographic information standards family. The semantic referencing is supported by application schemas (ISO 19109), feature catalogues [22], and ontologies (B.5). Concept projection between semantic space and semantic reference system transformation would be supported by the framework proposed in Clause 7, more especially within ISO 19150-3 defining semantic operators.

Annex C (informative)

Ontology matching

C.1 Introduction

Ontologies can support software agents in the interpretations of incoming data elements by providing meaning to these elements. Software agents can assign a meaning automatically to incoming data elements, which could be assembled in queries or results from an operation performed by another process, based on their ontologies. Such a function, also called interpretation, is made possible by ontology matching or similarity assessment.

C.2 Ontology matching

Ontology matching refers to the correspondence between semantically related entities of distinct ontologies [12]. It aims at finding concepts and/or properties from different ontologies that are related together, such as equivalence, subsumption, and disjointness. Mapping of concepts and properties between ontologies is not a trivial function. Typically, one or more concepts from one ontology can map to one concept of another ontology, and conversely. A similarity assessment between concepts supports the mapping between concepts. The similarity assessment can be either quantitative or qualitative. In quantitative assessment, the similarity typically takes the form of a semantic distance between concepts and is expressed in the interval $[0,1]$ where 0 means that the concepts are disjoint and 1 means that the concepts are equivalent. Qualitative similarity assessment takes the form of predicates that specify the relation between two concepts, such as *equal*, *include*, *overlap*, etc.

In the geographic information domain, the similarity between geometric constructs (point, curve, surface, and solid) is commonly identified by an intersection matrix between the interior, boundary, and exterior of two geometric objects, which lead to a 9-intersection matrix [11]. Although quantitative assessment of semantic similarity is interesting, qualitative assessment of semantic similarity is closer to cognitive reasoning. An approach that follows the same paradigm as for geometric similarity assessment (9-intersection matrix) would have the benefit of expressing the similarity in the same manner with the use of the same type of operators. The *geosemantic proximity* [6] approach is a 4 intersection matrix assessment of the semantic similarity between contexts of two geospatial concepts, which compares the intrinsic and extrinsic properties between two concepts. The context of a concept C can be represented using a geometric line metaphor (Figure C.1) where the intrinsic properties of the concept (denoted as C_k°) compare to the interior of the line and the extrinsic properties of the concept (denoted as ∂C_k), to the boundary of the line.

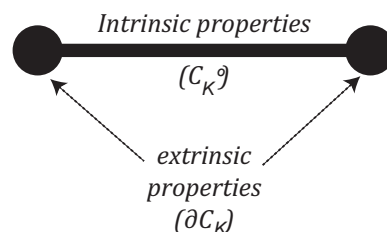

Figure C.1 — Concept's context segment metaphor

Then, the geosemantic proximity between two concept's contexts (denoted as C_k and C_L) is expressed through the intersection of the intrinsic and extrinsic properties (Figure C.2) and a matrix of predicates, denoted as $G_{SP}(K,L)$ is then defined.

Each matrix component is evaluated empty or not (denoted by Concept's context segment metaphor \emptyset / $\neg\emptyset$ or f / t respectively) and, hence, 16 geosemantic proximity predicates are derived: GsP_ffff (disjoint), GsP_ffft, GsP_fftt (contains), GsP_tfft (equal), GsP_ftft (inside), GsP_tftt (covers), GsP_ttft (coveredBy), GsP_fttt (overlap), GsP_tttt, GsP_tfff (meet), GsP_tftf, GsP_tttf, GsP_tfff, GsP_fttf, GsP_ftff.

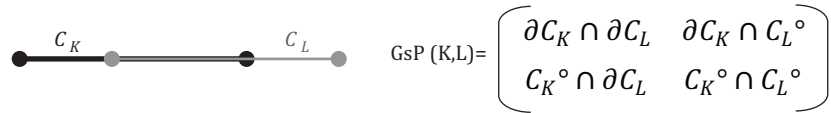

Figure C.2 — K and L Context Intersection

Semantic similarity assessment supports reasoning, which is the process from which one draws inferences or conclusions. This is possible when data elements can be interpreted.

EXAMPLES

IF ontologyA:street \subseteq ontologyA:road

AND ontologyA:road = ontologyB:thoroughfare

THEN ontologyA:street \subseteq ontologyB:thoroughfare

IF ontologyA:watercourse contains (or *GsP_fftt*) ontologyB:river/stream

AND ontologyB:river/stream contains (or *GsP_fftt*) ontologyC:creek

THEN ontologyA:watercourse contains (or *GsP_fftt*) ontologyC:creek

IF Joe is passenger of Train 1234

AND Train 1234 goes to Rome

THEN Joe goes to Rome

Ontologies provide the definitions of concepts and relationships between them with respect to some context. As such, reasoning and inference is then possible. Reasoning and inference can lead to a wide range of possibilities related to interoperability: data discovery, query answering, geographic data integration, and composition of geographic data with data from other sources and domains.

Bibliography

- [1] BAADER F., CALVANESE D., MCGUINNESS D.L., NARDI D., PATEL-SCHNEIDER P.F.eds. *The Description Logic Handbook: Theory, Implementation, and Applications*. Cambridge University Press, Cambridge, Second Edition, 2007
- [2] BERNERS-LEE T. *Linked Data – Design Issues*. 2007. Available at <<http://www.w3.org/DesignIssues/LinkedData.html>>
- [3] BERNERS-LEE T., HENDLER J., LASSILA O. The Semantic Web. *Sci. Am.* 2001, pp. 34–43
- [4] BITTNER T., & EDWARDS G. Toward an Ontology for Geomatics. *Geomatica*. 2001, **55** pp. 475–490
- [5] BRODEUR J., BÉDARD Y., MOULIN B. A Geosemantic Proximity-Based Prototype for Interoperability of Geospatial Data. *Comput. Environ. Urban Syst.* 2005, **29** pp. 669–698
- [6] BRODEUR J., BÉDARD Y., EDWARDS G., MOULIN B. Revisiting the Concept of Geospatial Data Interoperability within the Scope of a Human Communication Process. *Transactions in GIS*. 2003, **7** pp. 243–265
- [7] CHERRY C. *On Human Communication: a Review, a Survey, and a Criticism*. The MIT Press, 1978
- [8] DACONTA M.C., OBRST L.J., SMITH K.T. *The Semantic Web: A Guide to the Future of XML, Web Services, and Knowledge Management*. Wiley Publishing, Inc, 2003
- [9] ECO U. *Sémiotique et philosophie du langage*. Presses Universitaires de France, 1988
- [10] EGENHOFER M.J. 2002, *Toward the Semantic Geospatial Web*. In Proceedings of 10th ACM international symposium on Advances in geographic information systems, pp. 1-4
- [11] EGENHOFER M.J., & HERRING J.R. In: *Categorizing Binary Topological Relations Between Regions, Line and Points in Geographic Databases. The 9-Intersection: Formalism and Its Use for Natural-Language Spatial Predicates (Technical Report)*, vol. (Egenhofer M., Mark D.M., Herring J.R., eds.). NCGIA, 1994, pp. 1–28.
- [12] EUZENAT J., & SHVAIKO P. *Ontology Matching*. Springer, 2007
- [13] FONSECA F., & SHETH A. 2002, *The Geospatial Semantic Web (White Paper)*, vol., UCGIS
- [14] GÓMEZ-PÉREZ A., FERNÁNDEZ-LÓPEZ M., CORCHO O. *Ontological Engineering*. Springer Verlag, 2004, 403 p.
- [15] GRUBER T.R. Toward Principles for the Design of Ontologies Used for Knowledge Sharing. *Int. J. Hum. Comput. Stud.* 1995, **43** pp. 907–928
- [16] GUARINO N. 1998, *Formal Ontology and Information Systems*. In Proceedings of Formal Ontology in Information Systems (FOIS '98) (Trento, Italy), pp. 3-15
- [17] ISO 19101-1:—¹⁵⁾*Geographic information — Reference model — Part 1: Fundamentals*
- [18] ISO 19108:2002, *Geographic information — Temporal schema*
- [19] ISO 19107:2003, *Geographic information — Spatial schema*
- [20] ISO 19115:2003, *Geographic information — Metadata*
- [21] ISO 19125-1:2004, *Geographic information — Simple feature access — Part 1: Common architecture*
- [22] ISO 19110:2005, *Geographic information — Methodology for feature cataloguing*

15) To be published.

- [23] ISO 19141:2008, *Geographic information — Schema for moving features*
- [24] ISO 19144-2:—¹⁶⁾*Geographic information — Classification systems — Part 2: Land Cover Meta Language (LCML)*
- [25] ISO 19152:—, *Geographic information — Land Administration Domain Model (LADM)*
- [26] LASSILA O., & MCGUINNESS D.L. *The Role of Frame-Based Representation on the Semantic Web, vol., Knowledge Systems*. AI Laboratory, Stanford University, 2001
- [27] KUHN W., & RAUBAL M. Implementing Semantic Reference Systems. In Proceedings of 6th AGILE Conference on Geographic Information Science “The Science behind the Infrastructure”, 2003
- [28] KUHN W. Geospatial Semantics: Why, of What, and How? In: *Journal on Data Semantics III*, (Spaccapietra S., Zimányi E., eds.). Springer-Verlag, Berlin, Heidelberg, 2005, pp. 1–24.
- [29] LEHMANN F. Semantic Networks. *Comput. Math. Appl.* 1992, **23** p. 50
- [30] LIEBERMAN J., SINGH R., GOAD C. *W3C Geospatial Ontologies* W3C Incubator Group Report 23 October 2007. Available at <<http://www.w3.org/2005/Incubator/geo/XGR-geo-ont/>>
- [31] LUTZ C. *Description Logics*. Available at <<http://dl.kr.org/>>
- [32] OBJECT MANAGEMENT GROUP. *Ontology Definition Metamodel, vol., formal/2009-05-01*. OMG, Needham, MA, 2009
- [33] PEUQUET D., SMITH B., BROGAARD B. 1998. *The Ontology of Fields*. In Proceedings of Summer Assembly of the University Consortium for Geographic Information Science (Bar Harbor, Maine)
- [34] ROMAN D. et al. *Web Service Modeling Ontology*. Applied Ontology, 2005, pp. 77–106.
- [35] SMITH B., & MARK D. Ontology with Human Subjects Testing: An Empirical Investigation of Geographic Categories. *Am. J. Econ. Sociol.* 1999, **58** pp. 245–272
- [36] STUDER R., BENJAMINS V.R., FENSEL D. Knowledge Engineering: Principles and Methods. *Data Knowl. Eng.* 1998, **25** pp. 161–197
- [37] SYCARA K., PAOLUCCI M., SRINIVASAN N. 2005, *Combining Services and Semantics on the Web*. W3C Workshop on Frameworks for Semantics in Web Services, Innsbruck, Austria. Available at <<http://www.w3.org/2005/04/FSWS/accepted-papers.html>>
- [38] W3C, 2004, RDF Vocabulary Description Language 1.0:RDF Schema. BRICKLEY D., & GUHA R.V. eds. W3C
- [39] W3C, 2004, Resource Description Framework (RDF): Concepts and Abstract Syntax, KLYNE G., & CARROLL J.J. eds., W3C
- [40] W3C, 2004, XML Schema Part 1: Structures Second Edition, THOMPSON H.S., BEECH D., MALONEY M., MENDELSON N. eds., W3C
- [41] W3C, 2008, SPARQL Query Language for RDF, PRUD’HOMMEAUX E., & SEABORNE A. eds., W3C
- [42] W3C, 2009, OWL 2 Web Ontology Language: Structural Specification and Functional-Style Syntax, MOTIK B., PATEL-SCHNEIDER P.F., PARSIA B. eds., W3C
- [43] W3C, 2004. OWL-S: Semantic Markup for Web Services. Available at <<http://www.w3.org/Submission/OWL-S/>>

16) To be published.

British Standards Institution (BSI)

BSI is the national body responsible for preparing British Standards and other standards-related publications, information and services.

BSI is incorporated by Royal Charter. British Standards and other standardization products are published by BSI Standards Limited.

About us

We bring together business, industry, government, consumers, innovators and others to shape their combined experience and expertise into standards-based solutions.

The knowledge embodied in our standards has been carefully assembled in a dependable format and refined through our open consultation process. Organizations of all sizes and across all sectors choose standards to help them achieve their goals.

Information on standards

We can provide you with the knowledge that your organization needs to succeed. Find out more about British Standards by visiting our website at bsigroup.com/standards or contacting our Customer Services team or Knowledge Centre.

Buying standards

You can buy and download PDF versions of BSI publications, including British and adopted European and international standards, through our website at bsigroup.com/shop, where hard copies can also be purchased.

If you need international and foreign standards from other Standards Development Organizations, hard copies can be ordered from our Customer Services team.

Subscriptions

Our range of subscription services are designed to make using standards easier for you. For further information on our subscription products go to bsigroup.com/subscriptions.

With **British Standards Online (BSOL)** you'll have instant access to over 55,000 British and adopted European and international standards from your desktop. It's available 24/7 and is refreshed daily so you'll always be up to date.

You can keep in touch with standards developments and receive substantial discounts on the purchase price of standards, both in single copy and subscription format, by becoming a **BSI Subscribing Member**.

PLUS is an updating service exclusive to BSI Subscribing Members. You will automatically receive the latest hard copy of your standards when they're revised or replaced.

To find out more about becoming a BSI Subscribing Member and the benefits of membership, please visit bsigroup.com/shop.

With a **Multi-User Network Licence (MUNL)** you are able to host standards publications on your intranet. Licences can cover as few or as many users as you wish. With updates supplied as soon as they're available, you can be sure your documentation is current. For further information, email bsmusales@bsigroup.com.

BSI Group Headquarters

389 Chiswick High Road London W4 4AL UK

Revisions

Our British Standards and other publications are updated by amendment or revision.

We continually improve the quality of our products and services to benefit your business. If you find an inaccuracy or ambiguity within a British Standard or other BSI publication please inform the Knowledge Centre.

Copyright

All the data, software and documentation set out in all British Standards and other BSI publications are the property of and copyrighted by BSI, or some person or entity that owns copyright in the information used (such as the international standardization bodies) and has formally licensed such information to BSI for commercial publication and use. Except as permitted under the Copyright, Designs and Patents Act 1988 no extract may be reproduced, stored in a retrieval system or transmitted in any form or by any means – electronic, photocopying, recording or otherwise – without prior written permission from BSI. Details and advice can be obtained from the Copyright & Licensing Department.

Useful Contacts:

Customer Services

Tel: +44 845 086 9001

Email (orders): orders@bsigroup.com

Email (enquiries): cservices@bsigroup.com

Subscriptions

Tel: +44 845 086 9001

Email: subscriptions@bsigroup.com

Knowledge Centre

Tel: +44 20 8996 7004

Email: knowledgecentre@bsigroup.com

Copyright & Licensing

Tel: +44 20 8996 7070

Email: copyright@bsigroup.com



...making excellence a habit.™