

PD ISO/TS 18806:2014



BSI Standards Publication

# Solid mineral fuels — Determination of Chlorine content

**bsi.**

...making excellence a habit.™

### **National foreword**

This Published Document is the UK implementation of ISO/TS 18806:2014.

The UK participation in its preparation was entrusted to Technical Committee PTI/16, Solid mineral fuels.

A list of organizations represented on this committee can be obtained on request to its secretary.

This publication does not purport to include all the necessary provisions of a contract. Users are responsible for its correct application.

© The British Standards Institution 2015.

Published by BSI Standards Limited 2015

ISBN 978 0 580 83267 3

ICS 75.160.10

**Compliance with a British Standard cannot confer immunity from legal obligations.**

This Published Document was published under the authority of the Standards Policy and Strategy Committee on 31 January 2015.

### **Amendments/corrigenda issued since publication**

<b>Date</b>	<b>Text affected</b>
-------------	----------------------

---

**TECHNICAL  
SPECIFICATION**

**ISO/TS  
18806**

First edition  
2014-12-15

---

---

**Solid mineral fuels — Determination  
of Chlorine content**

*Combustibles minéraux solides — Dosage de la teneur en chlore*



Reference number  
ISO/TS 18806:2014(E)



## **COPYRIGHT PROTECTED DOCUMENT**

© ISO 2014

All rights reserved. Unless otherwise specified, no part of this publication may be reproduced or utilized otherwise in any form or by any means, electronic or mechanical, including photocopying, or posting on the internet or an intranet, without prior written permission. Permission can be requested from either ISO at the address below or ISO's member body in the country of the requester.

ISO copyright office  
Case postale 56 • CH-1211 Geneva 20  
Tel. + 41 22 749 01 11  
Fax + 41 22 749 09 47  
E-mail [copyright@iso.org](mailto:copyright@iso.org)  
Web [www.iso.org](http://www.iso.org)

Published in Switzerland

# Contents

	Page
<b>Foreword</b> .....	<b>iv</b>
<b>1 Scope</b> .....	<b>1</b>
<b>2 Normative references</b> .....	<b>1</b>
<b>3 Terms and definitions</b> .....	<b>1</b>
<b>4 Principle</b> .....	<b>1</b>
4.1 Method A — High temperature combustion in oxygen .....	1
4.2 Method B — Bomb combustion .....	1
<b>5 Reagent</b> .....	<b>2</b>
5.1 Method A.....	2
5.2 Method B.....	2
<b>6 Apparatus</b> .....	<b>2</b>
6.1 Method A.....	2
6.2 Method B.....	4
<b>7 Preparation of sample</b> .....	<b>4</b>
<b>8 Procedure</b> .....	<b>5</b>
8.1 Blank Value Determination.....	5
8.2 Method A.....	5
8.3 Method B — Bomb Combustion.....	5
<b>9 Determination of dissolved chloride</b> .....	<b>6</b>
9.1 General.....	6
9.2 Determination by ion chromatography.....	6
<b>10 Calculation and expression of results</b> .....	<b>7</b>
<b>11 Test report</b> .....	<b>7</b>
<b>Annex A (normative) Quality control</b> .....	<b>8</b>
<b>Annex B (Informative) Results of the German Interlaboratory comparison 2009 for DIN 51727:2011 “Solid fuels-Determination of the chlorine content”</b> .....	<b>9</b>
<b>Bibliography</b> .....	<b>11</b>

## Foreword

ISO (the International Organization for Standardization) is a worldwide federation of national standards bodies (ISO member bodies). The work of preparing International Standards is normally carried out through ISO technical committees. Each member body interested in a subject for which a technical committee has been established has the right to be represented on that committee. International organizations, governmental and non-governmental, in liaison with ISO, also take part in the work. ISO collaborates closely with the International Electrotechnical Commission (IEC) on all matters of electrotechnical standardization.

The procedures used to develop this document and those intended for its further maintenance are described in the ISO/IEC Directives, Part 1. In particular the different approval criteria needed for the different types of ISO documents should be noted. This document was drafted in accordance with the editorial rules of the ISO/IEC Directives, Part 2 (see [www.iso.org/directives](http://www.iso.org/directives)).

Attention is drawn to the possibility that some of the elements of this document may be the subject of patent rights. ISO shall not be held responsible for identifying any or all such patent rights. Details of any patent rights identified during the development of the document will be in the Introduction and/or on the ISO list of patent declarations received (see [www.iso.org/patents](http://www.iso.org/patents)).

Any trade name used in this document is information given for the convenience of users and does not constitute an endorsement.

For an explanation on the meaning of ISO specific terms and expressions related to conformity assessment, as well as information about ISO's adherence to the WTO principles in the Technical Barriers to Trade (TBT), see the following URL: [Foreword — Supplementary information](#).

The committee responsible for this document is ISO/TC 27, *Solid mineral fuels*, Subcommittee SC 5, *Methods of Analysis*.

# Solid mineral fuels — Determination of Chlorine content

## 1 Scope

This Technical Specification specifies two methods (high temperature combustion and bomb combustion) for the determination of chlorine in solid mineral fuels. It is applicable to hard coals, brown coals, coke, and tailings.

The chlorine in the digestion solution can be determined using different methods, e.g. an ion-selective electrode, coulometric or potentiometric titration, spectrophotometry, or ion chromatography. In this Technical Specification, the ion chromatographic separation with conductivity detection is described.

The method is applicable to determine the chlorine content higher than 0,005 per cent mass fraction.

## 2 Normative references

The following documents, in whole or in part, are normatively referenced in this document and are indispensable for its application. For dated references, only the edition cited applies. For undated references, the latest edition of the referenced document (including any amendments) applies.

ISO 687, *Solid mineral fuels — Coke — Determination of moisture in the general analysis test sample*

ISO 1170, *Coal and coke — Calculation of analyses to different bases*

ISO 1213-2, *Solid mineral fuels — Vocabulary — Part 2: Terms relating to sampling, testing and analysis*

ISO 5068-2, *Brown coals and lignites — Determination of moisture content — Part 2: Indirect gravimetric method for moisture in the analysis sample*

ISO 5725-2, *Accuracy (trueness and precision) of measurement methods and results — Part 2: Basic method for the determination of repeatability and reproducibility of a standard measurement method*

ISO 11722, *Solid mineral fuels — Hard coal — Determination of moisture in the general analysis test sample by drying in nitrogen*

EN ISO 10304-1, *Water quality — Determination of dissolved anions by liquid chromatography of ions — Part 1: Determination of bromide, chloride, fluoride, nitrate, nitrite, phosphate and sulfate*

## 3 Terms and definitions

For the purposes of this document, the terms and definitions given in ISO 1213-2 apply.

## 4 Principle

### 4.1 Method A — High temperature combustion in oxygen

The sample is combusted at high temperature in an oxygen atmosphere. The gaseous combustion products including the formed chloride are collected in a trap filled with water, in which they are dissolved.

### 4.2 Method B — Bomb combustion

The sample is combusted in a high pressure bomb in an oxygen atmosphere. The formed chloride is collected in an absorption solution inside the bomb.

## 5 Reagent

### 5.1 Method A

5.1.1 **Oxygen**, pure, with an assay of at least 99,5 % volume fraction.

5.1.2 **Combustion aid (optional)**, spectroscopic carbon or iron phosphate ( $\text{FePO}_4$ ).

### 5.2 Method B

5.2.1 **Oxygen**, pure, with an assay of at least 99,5 % volume fraction.

5.2.2 **Combustion aid (optional)**, paraffin, benzoic acid, polyethylene combustion bags, acetobutyrate capsules, or other suitable materials.

5.2.3 **Fuse**, ignition wire (e.g. platinum) and cotton fuse (optional).

Note A possible contribution of the cotton fuse to the chlorine content should be considered.

5.2.4 **Absorption solution**, either eluent used for ion chromatographic determination, or alkaline solution (e.g. 0,2 mol/l KOH or 0,1 mol/l NaOH), or deionised water.

## 6 Apparatus

### 6.1 Method A

6.1.1 **Fused silica combustion tube, absorber, and headpiece**, the sintered glass discs in the absorber and the headpiece shall have a pore size of 90  $\mu\text{m}$  to 150  $\mu\text{m}$  (see [Figure 1](#)).



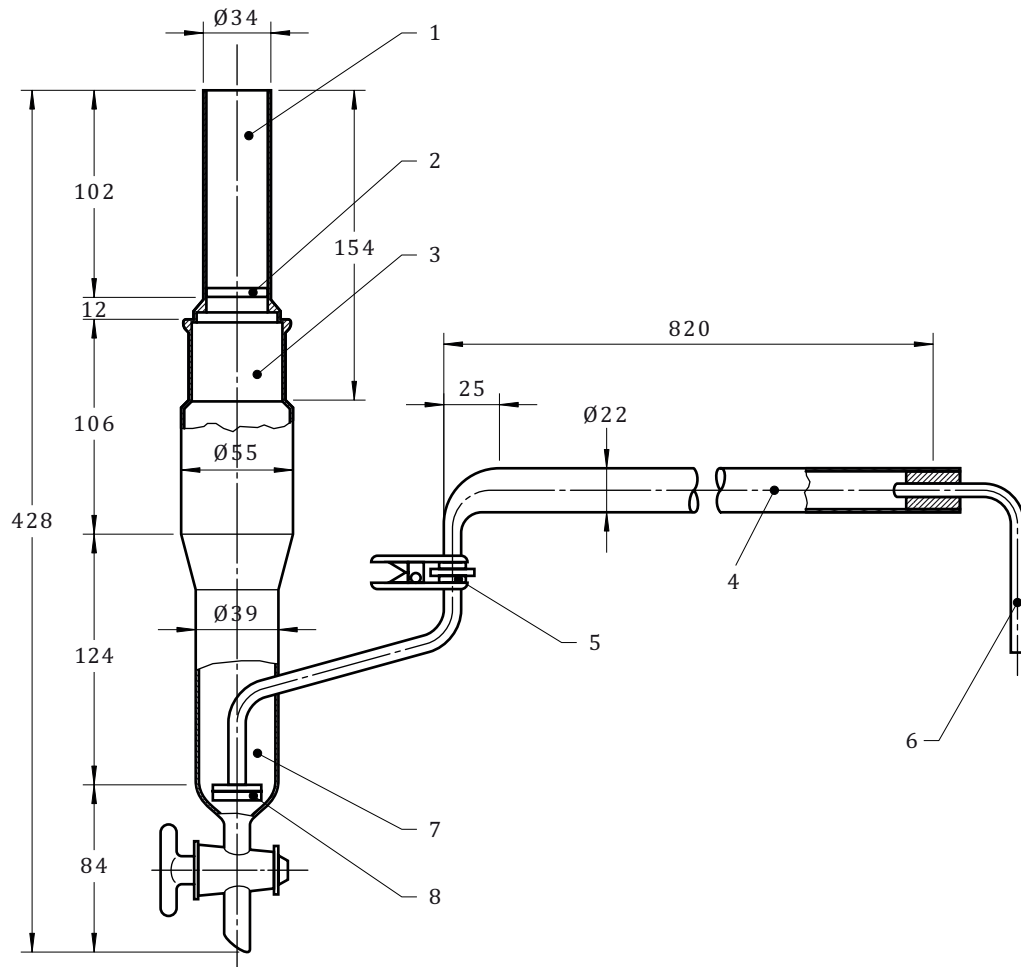

**Key**

- 1 headpiece
- 2 sintered glass disc
- 3 V45/50 conical ground joint (ISO 383)
- 4 combustion tube
- 5 VS 13 spherical joint (ISO 641)
- 6 oxygen inlet
- 7 absorber
- 8 sintered glass disc

**Figure 1 — Apparatus for Method A**

**6.1.2 Porcelain combustion boat**, with handle, e.g. 70 mm long, 10 mm wide, and 7 mm deep.

**6.1.3 Silica pusher**, with iron inlay (see [Figure 2](#)).

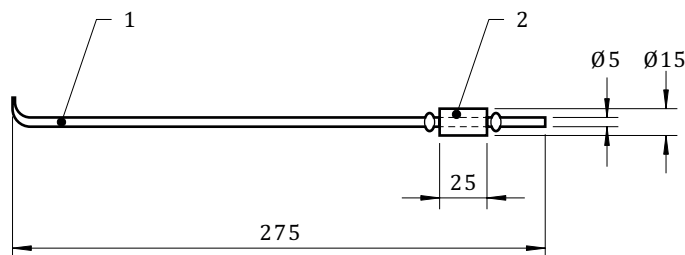

**Key**

- 1 silica pusher
- 2 iron inlay

**Figure 2 — Silica pusher**

**6.1.4 Magnet.**

**6.1.5 Electrical tube furnace**, about 300 mm long, capable of being heated to at least 1 300 °C and maintained at  $(1\,250 \pm 25)$  °C.

**6.1.6 Flow meter.**

**6.1.7 Oxygen inlet**, consisting of a pierced silicon stopper with a glass tube.

**6.2 Method B**

**6.2.1 Digestion unit**

**6.2.1.1 Digestion bomb**, with inner surface that is resistant to corrosion by acidic gases formed or emitted during combustion.

**6.2.1.2 Pressure regulator**, to control the filling of the bomb with oxygen and discharging afterwards.

**6.2.1.3 Pressure gauge**, with relieve valve operating at 3,5 MPa.

**6.2.1.4 Ignition circuit.**

If appropriate, the equipment for determination of calorific value according to ISO 1928 can be used simultaneously for chlorine determination. Attention is drawn to the fact that deionised water should be used as absorption solution and that 10 ml instead of 1 ml (as in ISO 1928) are used.

**6.2.2 Crucible**, of silica, nickel-chromium, platinum, or similar non-reactive material that is resistant to corrosion by acidic gases formed or emitted during combustion.

**7 Preparation of sample**

The coal or coke used for the determination of the chlorine content is the general analysis test sample ground to pass a sieve of 212  $\mu\text{m}$  aperture. Expose the sample in a thin layer for the minimum time required for the moisture content to reach approximate equilibrium with the laboratory atmosphere. Before commencing the determination, mix the air-dried sample.

After weighing the test portion (see 8.2.2 or 8.3.2), determine the moisture content using a further portion of the test sample by the method described in ISO 687, ISO 5068-2, or ISO 11722, as appropriate.

## 8 Procedure

### 8.1 Blank Value Determination

Blank values shall be measured by performing a complete analysis (method A or method B, whatever used for analysis of samples) without sample but including combustion aid, if used. Blank values should be measured on a daily basis or when series of analyses are started.

### 8.2 Method A

#### 8.2.1 Preparation

Adjust the tube furnace to ensure a temperature of  $(1\ 250 \pm 25)$  °C in the combustion zone. Place the combustion tube in the furnace so that its projecting vertical section with the spherical ground joint is as near as possible to the hottest zone to prevent any condensation of combustion products.

Adjust the oxygen flow to  $(1 \pm 0,1)$  l/min.

Mix samples having more than 30 % mass fraction ash with 0,1 g to 0,2 g of combustion aid to achieve uniform combustion.

#### 8.2.2 Combustion procedure

Weigh, to an accuracy of 0,1 mg, about 50 mg to 1 000 mg (depending on the chlorine concentration) of the sample prepared according to [Clause 7](#) into a combustion boat. Push the boat into the combustion tube using the silica pusher until the tube can be closed with the oxygen inlet.

NOTE Carefully place the front end of the pusher into the handle of the combustion boat. Otherwise problems to remove the boat after test might occur.

Fill the absorber with 150 ml deionised water. After starting the oxygen flow, mount the headpiece on the absorber and fill it with 20 ml deionised water.

To prevent deflagration, initially use the magnet to move the pusher together with the combustion boat containing the sample into the combustion zone so far only, that the front section of the sample is ignited only. After the sample has reached red heat (approximately one minute after ignition), push it into the combustion zone to burn it completely. High temperature coke samples can be pushed into the combustion zone directly.

Combustion time is depending on the ash of the sample. It is about 20 mins for coals having 10 % to 20 % mass fraction ash. After combustion has been terminated, transfer the absorption liquid from headpiece and absorber into a 250 ml volumetric flask. Rinse headpiece and absorber with deionised water and add to the flask. Fill up to the mark with deionised water ( $V_D$ ).

### 8.3 Method B — Bomb Combustion

#### 8.3.1 Preparation

Bomb parts shall be inspected regularly for wear and corrosion; particular attention shall be paid to the condition of the threads of the main closure. Manufacturers' instructions and any local regulations regarding the safe handling and use of the bomb shall be observed. Before starting a test ensure that no gas leakage occurs.

NOTE Gas leakage can be checked easily by complete immersing the pressurized bomb in cold water.

### 8.3.2 Combustion procedure

Weigh, to an accuracy of 0,1 mg, about 50 mg to 1 000 mg (depending on the chlorine concentration) of the sample prepared according to [Clause 7](#) into a crucible.

Note If appropriate, chlorine can be determined simultaneously with calorific value according to ISO 1928 (for details see [6.2.1](#)).

If not easily combusting samples are to be analysed, weigh into e.g. acetobutyrate capsules or use a combustion aid, e.g. benzoic acid.

Fill 10 ml of the absorption solution ([5.2.4](#)) into the bomb and wet the inner surface of the bomb, e.g. by carefully rotating it. Select an absorption solution that is capable to absorb the acidic combustion products completely.

Place the crucible in its support and fix it. Attach the ignition wire and assemble the bomb. Charge the bomb slowly with oxygen to a pressure of maximum  $(3,0 \pm 0,2)$  MPa. Initiate the combustion by firing the fuse. After the combustion is completed let the bomb cool down to ambient temperature. Release the pressure at a moderate rate and dismantle the bomb carefully.

Transfer the chlorine absorbed solution into a volumetric flask by either

- Addition of, e.g. 40 ml absorption solution ([5.2.4](#)) to the bomb, closing and shaking the bomb in such a manner as to rinse all interior surfaces of the bomb, the combustion crucible, and the pressure release valve with absorbing solution; and/or
- Rinsing all interior surfaces of the bomb, the combustion crucible, and the pressure release valve with absorbing solution ([5.2.4](#)).

Transfer all solutions into a volumetric flask (e.g. 100 ml or 50 ml, depending on the chlorine content) and fill up to the mark ( $V_D$ ) with absorption solution ([5.2.4](#)).

If appropriate, take an aliquot ( $V_A$ ), transfer it to another volumetric flask and fill up to the mark ( $V_M$ ) with absorption solution ([5.2.4](#)).

NOTE Before injecting the sample into the ion chromatograph, an aliquot of the sample solution can be filtered through an, e.g. 0,45  $\mu\text{m}$  disposable filter in order to protect the column.

## 9 Determination of dissolved chloride

### 9.1 General

The chloride content in the digestion solution can be determined using different methods, e.g. an ion-selective electrode, coulometric or potentiometric titration, spectrophotometry, or ion chromatography.

In this Technical Specification, the ion chromatographic separation with conductivity detection is described in detail.

### 9.2 Determination by ion chromatography

#### 9.2.1 General

The ion chromatographic separation with conductivity detection is performed according to EN ISO 10304-1.

As the chromatograms, especially retention times depend on concentrations and matrix, a calibration on the basis of matrix-adjusted reference materials is recommended.

## 9.2.2 Apparatus

— **Ion Chromatograph**, preferably with conductivity detection.

## 9.2.3 Reagent

— **Eluent**, suitable for the ion chromatographic equipment used.

## 10 Calculation and expression of results

Calculate the chlorine content in the solid mineral fuel from the chloride concentration in the digestion solution, the sample mass, blank values (if any, e.g. coming from combustion aid or eluent), and any dilution steps according to Formula (1):

$$w(Cl_{ad}) = \frac{(\beta_S - \beta_B) \times V_D}{m \times 10\,000} \times \frac{V_M}{V_A} \quad (1)$$

where

$w(Cl_{ad})$  is the chlorine content of the sample as analysed (air dried), given in per cent mass fraction;

$\beta_S$  is the mass concentration of chlorine in  $V_M$ , in milligrams per litre;

$\beta_B$  is the mass concentration of chlorine in the blank determination, in milligrams per litre;

$V_D$  is the volume of the digestion solution, in millilitres (e.g. Method A 250 ml; Method B 50 ml or 100 ml);

NOTE:  $V_D$  is the volume used for chloride determination if no dilution is necessary.

$V_M$  is the volume of the (diluted) solution used for chloride determination, in millilitres;

$V_A$  is the volume of the aliquot taken from the digestion solution, in millilitres;

$m$  is the mass of the test portion, in grams;

$V_M/V_A$  is the dilution factor. If no dilution has been made, this term will be equal to one ( $V_M/V_A = 1$ ).

Report the chlorine content in the air-dried sample, as average of duplicate determinations, for per cent mass fractions

- of  $>0,1$  % rounded to 0,01 % mass fraction, and
- of  $\leq 0,1$  % rounded to 0,001 % mass fraction.

For the calculation of results to other bases, refer to ISO 1170.

## 11 Test report

The test report shall include the following particulars:

- a) reference to this International Technical Specification (i.e. ISO/TS 18806);
- b) the identification of the sample tested;
- c) the results of the determination.

## **Annex A** **(normative)**

### **Quality control**

#### **A.1 Blank values**

Determine the blank values for each series of analyses if a combustion aid (e.g. benzoic acid) is used. For this purpose combust the combustion aid (e.g. benzoic acid) only.

If combustion aid is used regularly, the use of a blank value control chart is recommended.

#### **A.2 Reproducibility**

When starting a series of analyses a control sample (reference material with same matrix as the samples) shall be analysed for a function check of combustion and chromatographic equipment. If appropriate, pure organic substances (e.g. 5-chloro-2-hydroxy-benzoic acid) can be used.

NOTE The use of a control chart for these results is recommended.

## Annex B

### (Informative) Results of the German Interlaboratory comparison 2009 for DIN 51727:2011 “Solid fuels-Determination of the chlorine content”

In 2009, a national interlaboratory comparison was conducted in Germany by the national committee FABERG Working Group 12.2 ‘Testing of solid fuels’.

The results are listed in [Table B.1](#) for high temperature combustion and [Table B.2](#) for bomb combustion.

**Table B.1 — ILC results for method A (high temperature combustion)**

German ILC FABERG WG ‘Testing of solid fuels’ Chlorine (high temperature combustion)								
Sample	Russian hard coal	Brown coal (central German)	Brown coal (east German)	Imported hard coal 2	HT coke	Brown coal (Rhine basin)	German hard coal	Imported hard coal 1
Number of labora- tories	5	5	5	5	5	5	5	5
Number of labo- ratories (outliers removed)	4	5	5	5	5	5	5	5
Outliers	1	0	0	0	0	0	0	0
Average Chlorine (% mass fraction)	0,010	0,013	0,014	0,016	0,021	0,026	0,156	0,349
Repeatability standard devia- tion	0,000 5	0,003 3	0,001 5	0,001 3	0,000 6	0,001 9	0,002 8	0,010 6
Reproducibility standard devia- tion	0,007 7	0,004 6	0,005 1	0,005 5	0,004 0	0,003 0	0,005 5	0,013 8
Relative repeat- ability standard deviation	5,4	25,5	10,7	8,1	3,0	7,1	1,8	3,0
Relative repro- ducibility standard deviation	78	36	36	33	19	11	3,5	3,9

**Table B.2 — ILC results for method B (bomb combustion)**

<b>German ILC FABERG WG 'Testing of solid fuels' Chlorine (bomb combustion)</b>								
<b>Sample</b>	<b>Russian hard coal</b>	<b>Brown coal (central German)</b>	<b>Brown coal (east German)</b>	<b>Imported hard coal 2</b>	<b>HT coke</b>	<b>Brown coal (Rhine basin)</b>	<b>German hard coal</b>	<b>Imported hard coal 1</b>
Number of laboratories	7	6	6	6	7	6	7	7
Number of laboratories (outliers removed)	7	6	6	6	7	6	7	6
Outliers	0	0	0	0	0	0	0	1
Average Chlorine (% mass fraction)	0,018	0,019	0,020	0,023	0,024	0,030	0,157	0,357
Repeatability standard deviation	0,002 2	0,002 0	0,001 5	0,002 6	0,001 2	0,003 4	0,004 6	0,009 7
Reproducibility standard deviation	0,010 3	0,009 2	0,007 8	0,016 3	0,004 4	0,008 7	0,013 3	0,025 2
Relative repeatability standard deviation	12,2	10,5	7,4	11,2	5,1	11,4	2,9	2,7
Relative reproducibility standard deviation	58,0	49,1	39,0	71,6	18,0	29,2	8,5	7,1

In the German standard DIN 51727 the following precision data are given:

- **Precision (according ISO 5725-2);**
- **Repeatability limit.**

The results of duplicate determinations, carried out in the same laboratory by the same operator with the same apparatus within a short interval of time on the same analysis sample, shall not differ by more than 0,02 % mass fraction (absolute).

- **Reproducibility limit**

The means of the results of duplicate determinations carried out in each of two laboratories, on representative portions taken from the same sample at the last stage of sample preparation, shall not differ by more than 0,03 % mass fraction (absolute).



## Bibliography

- [1] ISO 383, *Laboratory glassware — Interchangeable conical ground joints*
- [2] ISO 641, *Laboratory glassware — Interchangeable spherical ground joints*
- [3] ISO 1928, *Solid mineral fuels — Determination of gross calorific value by the bomb calorimetric method and calculation of net calorific value*
- [4] DIN 51727:2011 *Solid fuels — Determination of the chlorine content*





# British Standards Institution (BSI)

BSI is the national body responsible for preparing British Standards and other standards-related publications, information and services.

BSI is incorporated by Royal Charter. British Standards and other standardization products are published by BSI Standards Limited.

## About us

We bring together business, industry, government, consumers, innovators and others to shape their combined experience and expertise into standards-based solutions.

The knowledge embodied in our standards has been carefully assembled in a dependable format and refined through our open consultation process. Organizations of all sizes and across all sectors choose standards to help them achieve their goals.

## Information on standards

We can provide you with the knowledge that your organization needs to succeed. Find out more about British Standards by visiting our website at [bsigroup.com/standards](http://bsigroup.com/standards) or contacting our Customer Services team or Knowledge Centre.

## Buying standards

You can buy and download PDF versions of BSI publications, including British and adopted European and international standards, through our website at [bsigroup.com/shop](http://bsigroup.com/shop), where hard copies can also be purchased.

If you need international and foreign standards from other Standards Development Organizations, hard copies can be ordered from our Customer Services team.

## Subscriptions

Our range of subscription services are designed to make using standards easier for you. For further information on our subscription products go to [bsigroup.com/subscriptions](http://bsigroup.com/subscriptions).

With **British Standards Online (BSOL)** you'll have instant access to over 55,000 British and adopted European and international standards from your desktop. It's available 24/7 and is refreshed daily so you'll always be up to date.

You can keep in touch with standards developments and receive substantial discounts on the purchase price of standards, both in single copy and subscription format, by becoming a **BSI Subscribing Member**.

**PLUS** is an updating service exclusive to BSI Subscribing Members. You will automatically receive the latest hard copy of your standards when they're revised or replaced.

To find out more about becoming a BSI Subscribing Member and the benefits of membership, please visit [bsigroup.com/shop](http://bsigroup.com/shop).

With a **Multi-User Network Licence (MUNL)** you are able to host standards publications on your intranet. Licences can cover as few or as many users as you wish. With updates supplied as soon as they're available, you can be sure your documentation is current. For further information, email [bsmusales@bsigroup.com](mailto:bsmusales@bsigroup.com).

## BSI Group Headquarters

389 Chiswick High Road London W4 4AL UK

## Revisions

Our British Standards and other publications are updated by amendment or revision.

We continually improve the quality of our products and services to benefit your business. If you find an inaccuracy or ambiguity within a British Standard or other BSI publication please inform the Knowledge Centre.

## Copyright

All the data, software and documentation set out in all British Standards and other BSI publications are the property of and copyrighted by BSI, or some person or entity that owns copyright in the information used (such as the international standardization bodies) and has formally licensed such information to BSI for commercial publication and use. Except as permitted under the Copyright, Designs and Patents Act 1988 no extract may be reproduced, stored in a retrieval system or transmitted in any form or by any means – electronic, photocopying, recording or otherwise – without prior written permission from BSI. Details and advice can be obtained from the Copyright & Licensing Department.

## Useful Contacts:

### Customer Services

**Tel:** +44 845 086 9001

**Email (orders):** [orders@bsigroup.com](mailto:orders@bsigroup.com)

**Email (enquiries):** [cservices@bsigroup.com](mailto:cservices@bsigroup.com)

### Subscriptions

**Tel:** +44 845 086 9001

**Email:** [subscriptions@bsigroup.com](mailto:subscriptions@bsigroup.com)

### Knowledge Centre

**Tel:** +44 20 8996 7004

**Email:** [knowledgecentre@bsigroup.com](mailto:knowledgecentre@bsigroup.com)

### Copyright & Licensing

**Tel:** +44 20 8996 7070

**Email:** [copyright@bsigroup.com](mailto:copyright@bsigroup.com)



...making excellence a habit.™