

PD ISO/TS 17929:2014



BSI Standards Publication

# Biomechanical effects on amusement ride passengers

**bsi.**

...making excellence a habit.™

### **National foreword**

This Published Document is the UK implementation of ISO/TS 17929:2014.

The UK participation in its preparation was entrusted by Technical Committee MCE/3, Safeguarding of machinery, to Subcommittee MCE/3/4, Fairground and amusement park machinery and structures - Safety.

A list of organizations represented on this committee can be obtained on request to its secretary.

This publication does not purport to include all the necessary provisions of a contract. Users are responsible for its correct application.

© The British Standards Institution 2014.  
Published by BSI Standards Limited 2014

ISBN 978 0 580 82349 7  
ICS 13.180; 97.200.40

**Compliance with a British Standard cannot confer immunity from legal obligations.**

This Published Document was published under the authority of the Standards Policy and Strategy Committee on 30 September 2014.

### **Amendments/corrigenda issued since publication**

<b>Date</b>	<b>Text affected</b>
-------------	----------------------

---

# TECHNICAL SPECIFICATION

# ISO/TS 17929

First edition  
2014-09-15

---

---

## Biomechanical effects on amusement ride passengers

*Effets biomécaniques sur les passagers des manèges*



Reference number  
ISO/TS 17929:2014(E)



**COPYRIGHT PROTECTED DOCUMENT**

© ISO 2014

All rights reserved. Unless otherwise specified, no part of this publication may be reproduced or utilized otherwise in any form or by any means, electronic or mechanical, including photocopying, or posting on the internet or an intranet, without prior written permission. Permission can be requested from either ISO at the address below or ISO's member body in the country of the requester.

ISO copyright office  
Case postale 56 • CH-1211 Geneva 20  
Tel. + 41 22 749 01 11  
Fax + 41 22 749 09 47  
E-mail [copyright@iso.org](mailto:copyright@iso.org)  
Web [www.iso.org](http://www.iso.org)

Published in Switzerland

# Contents

	Page
Foreword .....	iv
Introduction .....	v
<b>1 Scope .....</b>	<b>1</b>
<b>2 Normative references .....</b>	<b>1</b>
<b>3 Terms and definitions .....</b>	<b>1</b>
<b>4 Degrees of potential biomechanical risks for amusement rides .....</b>	<b>3</b>
<b>5 Measures for elimination or reduction of hazards due to biomechanical effects .....</b>	<b>5</b>
<b>6 Effects of accelerations on passengers .....</b>	<b>7</b>
<b>7 Zones of potential biomechanical risk in the reach envelope of passengers for motion risk analysis and unscheduled braking risk analysis .....</b>	<b>7</b>
<b>Annex A (informative) Body dimensions of passengers from 1,20 m up to 2,0 m tall for motion risk analysis and unexpected braking risk analysis .....</b>	<b>8</b>
<b>Annex B (informative) Recommended acceleration limits .....</b>	<b>13</b>
<b>Annex C (informative) Hazard of passengers being held in an upside-down position in emergency .....</b>	<b>20</b>
<b>Annex D (informative) Use of amusement rides considering the state of health or well-being of passengers — Warning signs to advise passengers .....</b>	<b>21</b>
<b>Bibliography .....</b>	<b>23</b>

## Foreword

ISO (the International Organization for Standardization) is a worldwide federation of national standards bodies (ISO member bodies). The work of preparing International Standards is normally carried out through ISO technical committees. Each member body interested in a subject for which a technical committee has been established has the right to be represented on that committee. International organizations, governmental and non-governmental, in liaison with ISO, also take part in the work. ISO collaborates closely with the International Electrotechnical Commission (IEC) on all matters of electrotechnical standardization.

The procedures used to develop this document and those intended for its further maintenance are described in the ISO/IEC Directives, Part 1. In particular the different approval criteria needed for the different types of ISO documents should be noted. This document was drafted in accordance with the editorial rules of the ISO/IEC Directives, Part 2 (see [www.iso.org/directives](http://www.iso.org/directives)).

Attention is drawn to the possibility that some of the elements of this document may be the subject of patent rights. ISO shall not be held responsible for identifying any or all such patent rights. Details of any patent rights identified during the development of the document will be in the Introduction and/or on the ISO list of patent declarations received (see [www.iso.org/patents](http://www.iso.org/patents)).

Any trade name used in this document is information given for the convenience of users and does not constitute an endorsement.

For an explanation on the meaning of ISO specific terms and expressions related to conformity assessment, as well as information about ISO's adherence to the WTO principles in the Technical Barriers to Trade (TBT) see the following URL: Foreword - Supplementary information

The committee responsible for this document is ISO/TC 254, *Safety of amusement rides and amusement devices*.

## Introduction

Most passenger-carrying devices, e.g. vehicles, transport systems, elevators, cableways, and other similar structures, are deliberately designed to minimize biomechanical effects on passengers. Amusement rides are different in that the biomechanical effects are deliberately introduced in order to amuse people through stimulation of their sensory system.

Thus, in addition to mechanical, electrical and other hazards, amusement rides could feature significant biomechanical hazards for passengers. Passengers being moved by amusement rides are subject to inertia forces. The magnitude, direction, duration of exposure to, and rate of change of, these forces could create risks that need to be minimized. The risks may be increased by the use of entertaining effects.

Design of the amusement ride in accordance with this Technical Specification, together with ISO 17842, minimizes any risks from these biomechanical effects.

When it is important for safety reasons, passenger weight, height, and age also need to be considered.

Moreover, amusement ride passengers can have different states of health or well-being during a ride cycle and there is a probability of injury not due to any amusement ride defect but owing to the individual health state of a passenger. When a designer, manufacturer or operator provides a warning before the ride entrance for guests, making them aware of ride use restrictions considering their state of health (see [Annex D](#)), this can limit legal liability for possible harm to passengers in poor health.

# Biomechanical effects on amusement ride passengers

## 1 Scope

This Technical Specification has been drawn up with the objective of ensuring the safety of amusement ride passengers, based on the international experience of manufacture and operation of such structures throughout the world gained over decades prior to its publication.

It enables the identification of potential hazards and classification of biomechanical effects, including information on recommended acceleration limits, rate of their onset and their duration, to ensure acceptable degrees of biomechanical risks at the stage of amusement ride design, as well as to take such risks into account during development of operational procedures and information on use limitations for amusement ride guests.

It gives recommendations regarding use limitations for amusement rides in accordance with the health condition and the well-being of passengers. It also specifies body dimensions of passengers 1,20 m to 2,0 m in height for motion risk analysis on amusement rides. These body dimensions can be taken into account when designing passenger containments and restraints.

It does not cover devices used in the circus, theatre or sports, or other devices intended for use only by specially trained people. Nevertheless, it can be used in the design of any similar structural or passenger-carrying device even if it does not explicitly mention the device.

This Technical Specification is not applicable to amusement rides put into operation before the date of its publication.

## 2 Normative references

The following documents, in whole or in part, are normatively referenced in this document and are indispensable for its application. For dated references, only the edition cited applies. For undated references, the latest edition of the referenced document (including any amendments) applies.

ISO 17842 (all parts)—<sup>1)</sup>, *Safety of amusement rides and amusement devices*

## 3 Terms and definitions

For the purposes of this document, the following terms and definitions apply.

### 3.1

#### **amusement ride**

equipment that is designed to entertain the passengers during motion, including biomechanical effects

### 3.2

#### **biomechanical effects**

effects of forces on passengers of amusement rides associated with their motion

### 3.3

#### **degree of potential biomechanical risk**

likelihood of causing harm as a result of biomechanical effects of different values considering the possible severity of consequences

---

1) To be published.



**3.4**  
**entertaining effect**

**psycho-emotional effect**

action on the human sense organs associated with the use of visual effects, illumination, darkness, fire, water, wind, sounds, smells, etc. with the purpose of entertaining people

**3.5**  
**fence**

structure designed to restrict or prevent movement across a boundary

**3.6**  
**high potential biomechanical risk degree**

**RB-1**

potential of causing fatal harm to a passenger or passengers resulting from biomechanical effects

**3.7**  
**low potential biomechanical risk degree**

**RB-3**

potential of causing harm with temporary disability of a passenger or passengers resulting from biomechanical effects.

**3.8**  
**medium potential biomechanical risk degree**

**RB-2**

potential of causing severe harm to health of a passenger or passengers resulting from biomechanical effects

**3.9**  
**motion risk envelope**

zones around the bodies of passengers carried by the amusement ride within the reach envelopes in which, if it is intruded by any structures or foreign obstacles, the passengers may be exposed to harm of varying degrees of severity

**3.10**  
**negligible potential biomechanical risk degree**

**RB-4**

potential of causing harm without any form of disability to a passenger or passengers resulting from biomechanical effects

**3.11**  
**passenger containment**

components (e.g. seating, foot wells, handrails, and passenger restraints) designed to prevent passengers from moving outside a predetermined area on a ride either as a result of biomechanical effects or the ride forces or the behaviour of the passenger

**3.12**  
**rate of onset of acceleration**

value that characterizes the rate of acceleration growth during the given time interval (third derivative of movement in time)

**3.13**  
**restraint**

system, device, or characteristic that is intended to inhibit or restrict the body movement and/or keep the body position to tolerate accelerations of the passenger(s) while on the amusement ride

**3.14**  
**use limitation**

limitation for passengers with health deviations including but not limited to reasons related to their age, height or weight as well as for guests who are not feeling well to use an amusement ride safely

## 4 Degrees of potential biomechanical risks for amusement rides

When people are being moved by an amusement ride, the respective potential risks of harm may be present depending on the potential fall height, values of velocity and accelerations, angle of the seat inclination or turnover. Therefore, measures to reduce or eliminate risks shall be taken with regard to the types and degrees of biomechanical effects acting on passengers. In order to analyse the risks and possible consequences of failures, it is important to take into account how people are exposed to biomechanical effects and the frequency of such exposure.

Biomechanical effects produced by amusement rides are not always suitable for people with health problems or who are simply not feeling well at the time, and therefore it is necessary to warn people of how extreme the amusement ride may be and of any use limitations.

Types of injuries depending on the severity of harm to the human body can include but are not limited to

- a) traumatic brain injury (TBI),
- b) vascular injury due to turning upside down,
- c) cardiac arrhythmia due to stress and/or accelerations action,
- d) severe injury of internal organs due to impact,
- e) injury of a musculoskeletal system when exposed to high accelerations, and
- f) loss of consciousness due to accelerations.

If the safety measures taken are not adequate, any biomechanical effects of an RB-1 value may cause catastrophic harm to health or life of people, those effects may, for example, include falling from the height of over 8 m; being hit against an obstacle at a speed of higher than 20 m/s; ejection of an unrestrained passenger out of a passenger unit; falling of an unrestrained passenger headlong out of a turned over passenger unit or seat from the height of more than 3 m.

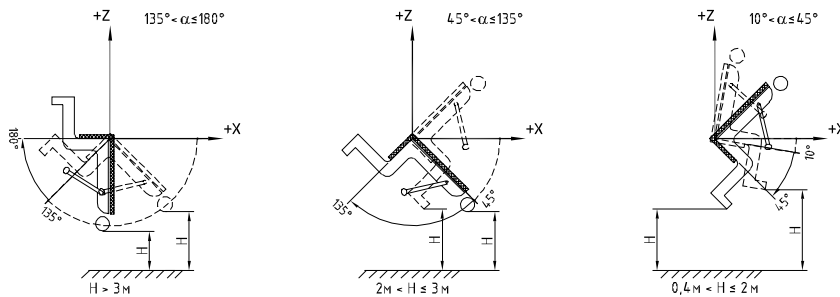
Similarly, any biomechanical effects of an RB-2 value may cause critical harm to health, including a severe injury or disability, and any biomechanical effects of an RB-3 value may cause harm to health such as temporary disorder. It should be noted that, if safety measures are insufficient and any unfavourable events or situations occur, increased biomechanical effects may result in high risk which will require risk analysis.

Identification of types and values of effects and degree of potential biomechanical risks shall be performed using [Table 1](#), [Figures 1 a\)](#), [1 b\)](#), and [1 c\)](#) illustrate inclination types of passenger seats.

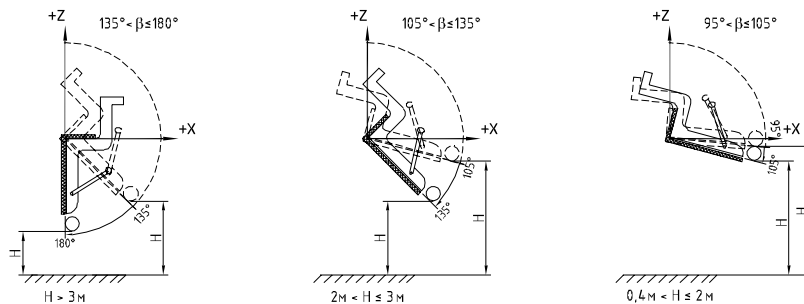
**Table 1 — Types and values of effects to which passengers are exposed and degrees of potential biomechanical risks**

Type of biomechanical effect	Notation	Degree of potential biomechanical risk			
		RB-1	RB-2	RB-3	RB-4
Lift to or drop from a relative height <sup>a</sup>	$H, m$	$H > 8$	$2 < H \leq 8$	$0,4 < H \leq 2$	$H \leq 0,4$
Travel at a relative velocity	$V, m/s$	$V > 20$	$10 < V \leq 20$	$3 < V \leq 10$	$V \leq 3$
Lift or drop in seat with inclination:	$H, m$	$H \geq 3$	$2 < H \leq 3$	$0,4 < H \leq 2$	$H < 0,4$
— forward inclination [Figure 1 a)]	$\alpha, \text{degrees}$	$135 < \alpha \leq 180$	$45 < \alpha \leq 135$	$10 < \alpha \leq 45$	
— backward inclination [Figure 1 b)]	$\beta, \text{degrees}$	$135 < \beta \leq 180$	$105 < \beta \leq 135$	$95 < \beta \leq 105$	
— sideward inclination [Figure 1 c)]	$\gamma, \text{degrees}$	$120 \leq \gamma \leq 180$	$60 \leq \gamma \leq 120$	$30 < \gamma \leq 60$	

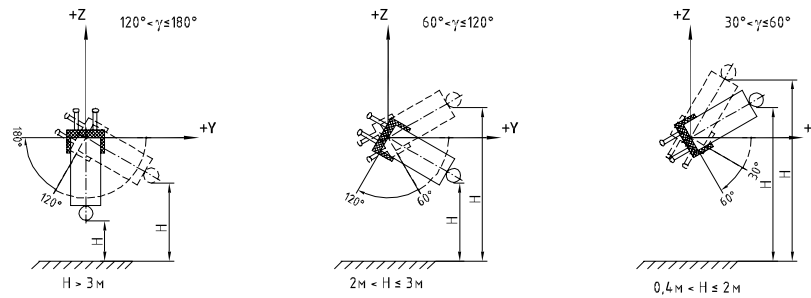
<sup>a</sup> The degrees of biomechanical risks are based on the statistics regarding consequences of injuries to people when falling from height.



**a) Forward inclination**



**b) Backward inclination**



**c) Sideward inclination**

**Figure 1 — Degrees of potential biomechanical risks depending on height and/or inclination for a seated unrestrained passenger**

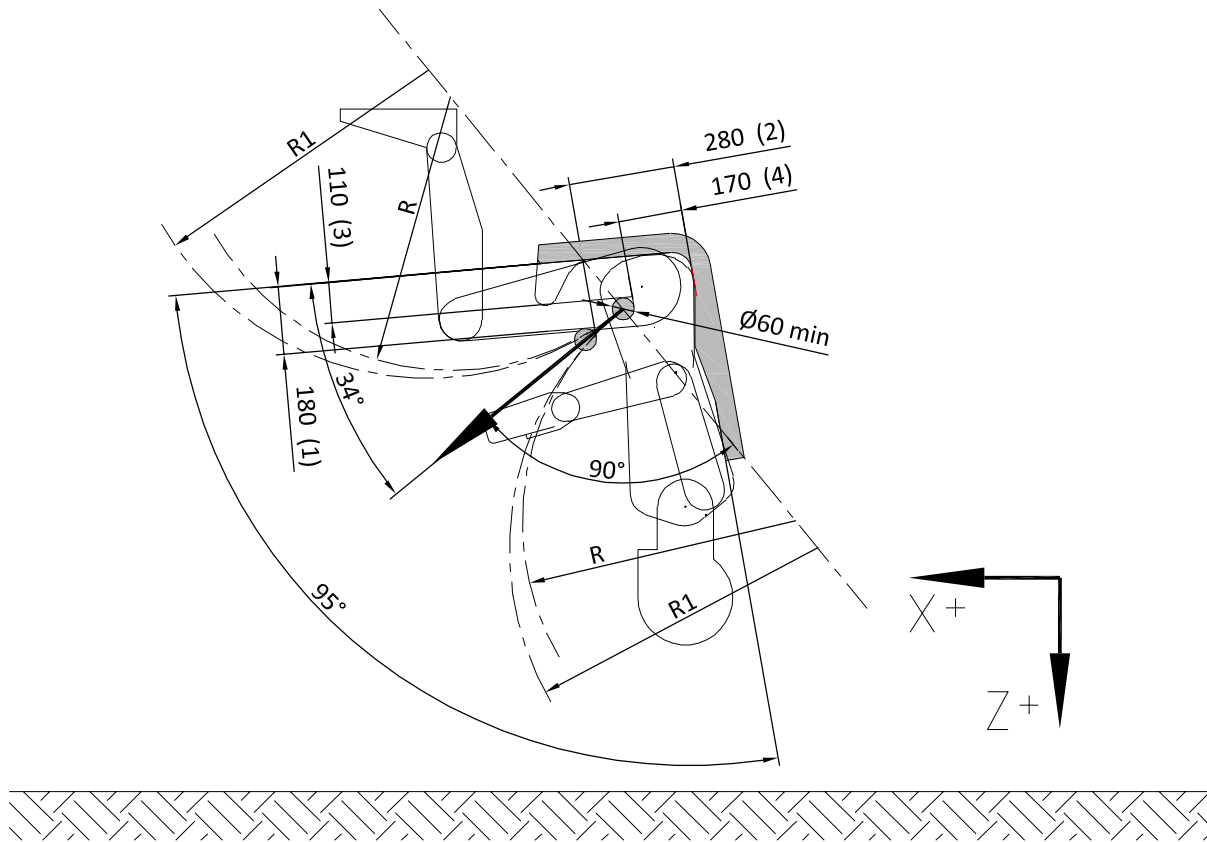
**5 Measures for elimination or reduction of hazards due to biomechanical effects**

Biomechanical risk analysis and risk classification for amusement rides concentrate the attention of those who make and maintain amusement rides on the elements and parameters most important for the safety of amusement rides.

Biomechanical risks arising from the types of effects listed below shall be eliminated or reduced by means of the following basic methods, in accordance with ISO 17842-1, and the necessity for redundancy depends on the risk analysis:

- when passengers are at a height of more than 2 m, reliable load-carrying structures and fences with due allowance for wind effects shall be provided as well as appropriate lifts and hoists;
- when passengers are being moved at a high speed (more than 3 m/s), appropriate containment devices shall be provided to prevent falling or potential ejection of passengers taking into account effects of inertia — measures shall be taken to remove obstacles that may cause harm getting into the relevant motion envelopes of passengers;
- when passengers are moved with high accelerations comparable with allowable limits for each axis, the passenger's body shall be secured with a restraint in order to ensure that accelerations are safely tolerated and to eliminate risk of passenger ejection due to acceleration (including under normal and emergency braking);
- when seats or passenger units are turned over and there is a probability of passengers falling out, appropriate passenger containment shall be provided.

Passenger containment may include restraints as part of the containment system. [Figure 2](#) provides an example of the geometry of the contact of a lap-bar type restraint with a passenger.



**Key**

- (1) thigh clearance (the highest point of the thigh above the sitting surface) (measurement 27, Reference [8])
- (2) body depth, sitting – a horizontal distance between the seat back and anterior protrusion of the body (measurement 36, Reference [8])
- (3) thigh clearance for an anthropometric model of 1200 mm in height (scaling down of measurement 27 given in Reference [8])
- (4) horizontal distance between the seat back and anterior protrusion of the body for an anthropometric model of 1200 mm in height (scaling down of measurement 36 given in Reference [8])

**Figure 2 — Example of the size and position of a restraint bar to hold passengers when turning upside down in emergency**

A complete passenger containment system shall be designed and verified by ergonomic testing.

To accommodate a passenger in an upside down position, other passenger containment systems may be designed.

These provisions are applicable for passengers of 1,20 m to 2,0 m in height.

To take necessary design and organizational safety measures for minimising risks originated from amusement rides, the experience of the designers, manufacturers, and operators shall be in conformity with the complexity of an amusement ride and with the degree of its biomechanical hazard.

Elimination or reduction of high degree biomechanical risks shall be provided using the following safety measures:

- designing amusement rides in accordance with the ISO 17842-1 standard requirements;

- using seats and restraint systems ensuring the permanence of the passenger's position; safety of the position is confirmed by mathematic simulation of accelerations acting on the passenger;
- limiting accelerations acting on the passenger with parameters specified in this Technical Specification;
- advising passengers of possible harm while using the amusement ride depending on their state of health. Warnings shall be clear and legible and shall be displayed at the entrance of an amusement ride as well as duplicated at the loading platform.

The safety measures taken at the design stage shall be continuously maintained and verified at all the relevant stages of the ride manufacture and operation.

## **6 Effects of accelerations on passengers**

When designing amusement rides where passengers are exposed to accelerations, it is necessary to take into consideration possible unfavourable effects of accelerations on the human body.

The manifestations of such effects are described in [Annex B](#).

[Annex B](#) also contains consolidated diagrams of recommended limit accelerations for different directions of their actions.

## **7 Zones of potential biomechanical risk in the reach envelope of passengers for motion risk analysis and unscheduled braking risk analysis**

The risk of injury for passengers during riding results from potential intrusion of obstacles into the relevant zone around the passenger. Sizes of the zones taking into account the severity of injuries depend on the anthropometric data of passengers, restraint systems, and speed of relative motion. Obstacles, such as people, animals and birds, decorations, tents, branches of trees, etc. may cause injury, so it is required to provide measures, according to the risk analysis, for the zones to be enlarged and to surround the relevant area with fencing or to remove all obstacles within the appropriate space.

Sizes of envelopes when passengers are being moved and those for unscheduled braking are given in [Annex A](#).

## Annex A (informative)

### Body dimensions of passengers from 1,20 m up to 2,0 m tall for motion risk analysis and unexpected braking risk analysis

Sizes of motion risk envelopes are calculated for passengers from 1,20 m up to 2,0 m tall using a method of allowable movement of the human body and limbs based on 99th percentile with the stature of 1 900 mm having been adjusted to 2 000 mm (according to Reference [8]). The size of motion risk envelopes is given in [Figures A.1](#) to [A.6](#).

Measurements shown in the figures are taken from the sources listed below.

An anthropometric model to produce the following [Figures A.1](#) to [A.6](#) has been made by scaling up of the original model with height of 1 900 mm (99th percentile as per Reference [8]) up to 2 000 mm (99th percentile as per ISO 15534-3:2000, 1 944 mm).

- (1) Head turning angle (Reference [5], angle  $\gamma_3$ , [Figure 1c](#), [Table 1](#))
- (2) Lower leg turning angle (Reference [5], angle  $\gamma_6$ , [Figure 1 c](#), [Table 1](#))
- (3) Body inclination until it reaches the position when the height of the lifted arm is maximum
- (4) Turning until contacting the side wall of the seat with height of 200 mm
- (5) Maximum body (shoulder) breadth — horizontal breadth across the shoulders, measured to the protrusions of the deltoids with arms hanging freely downwards (measurement 17, Reference [8])
- (6) Maximum horizontal distance between the deltoid of the left arm hanging freely and fingertips of the right arm stretched out sideways (measurement 14, Reference [8])
- (7) Sitting height — vertical distance from the sitting surface to the vertex (measurement 22, Reference [8])
- (8) Maximum vertical distance between the seat surface and fingertips of the arm stretched out upwards (compilation of measurements of other postures as per Reference [8])
- (9) Shoulder joint range of motion, vertically (experimental data)
- (10) Head turning angle (Reference [5], angle  $\alpha_3$ , [Figure 1 a](#), [Table 1](#))
- (11) Vertical arm reach, standing (measurement 21, Reference [8])
- (12) Stature (body height) (measurement 1, Reference [8])
- (13) Foot turning angle (Reference [5], angle  $\alpha_8$ , [Figure 1 a](#), [Table 1](#))
- (14) Maximum body depth (anterior-posterior dimension), standing — horizontal distance between the vertical reference planes going through the anterior and posterior protrusions of the body (measurement 18, Reference [8])
- (15) Vertical adjustment of the passenger restraint system
- (16) Turning angle of the shoulder joint (Reference [5], angle  $\beta_4$ , [Figure 1 b](#), [Table 1](#))

- (17) Arms outstretched (span) (measurement 13, Reference [8])
- (18) Hand turning angle (Reference [5], angle  $\beta_1$ , Figure 1 b), Table 1)
- (19) Forward arm reach (measurement 19, Reference [8])

Figures A.1 to A.6 show dimensions of motion risk envelopes for passengers of amusement rides.

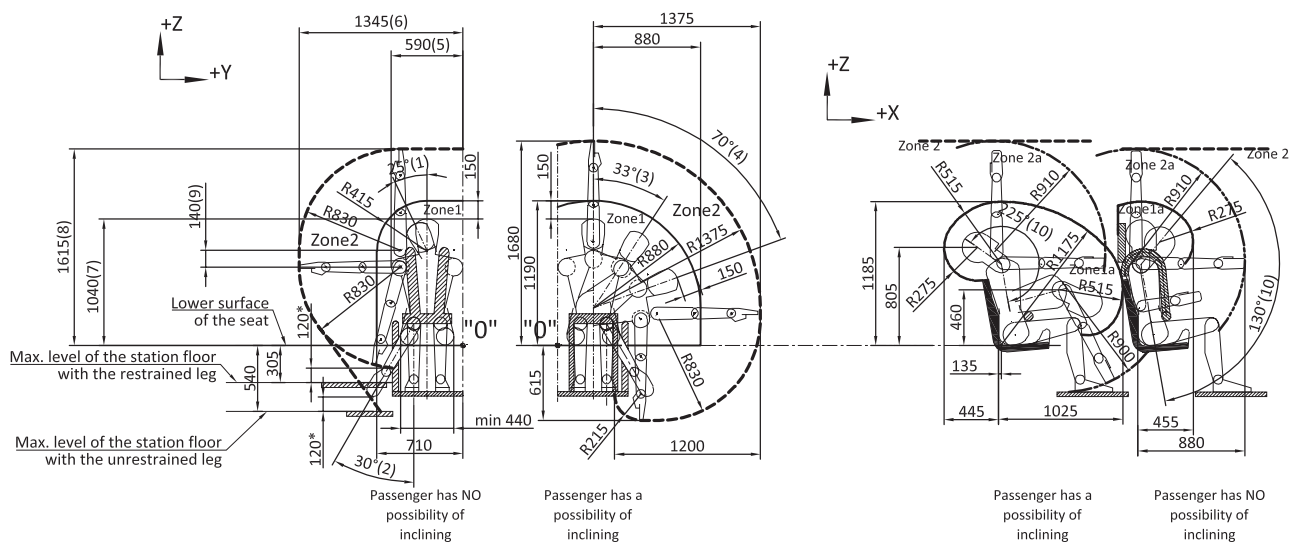
Zone 1 — zone with potential biomechanical risk of high degree (RB-1) at a motion speed  $V > 3$  m/s — a mandatory zone.

Zone 2 — zone with potential biomechanical risk of medium degree (RB-2), for speed  $V > 3$  m/s — a mandatory zone; and zone with biomechanical risk of low degree (RB-3), for speed  $V \leq 3$  m/s — a recommended zone.

Figures A.1 to A.6 show dimensions of motion risk envelopes for passengers of amusement rides during braking.

Zone 1a — zone with potential biomechanical risk of high degree at off-nominal (emergency) braking (RB-2) – a mandatory zone.

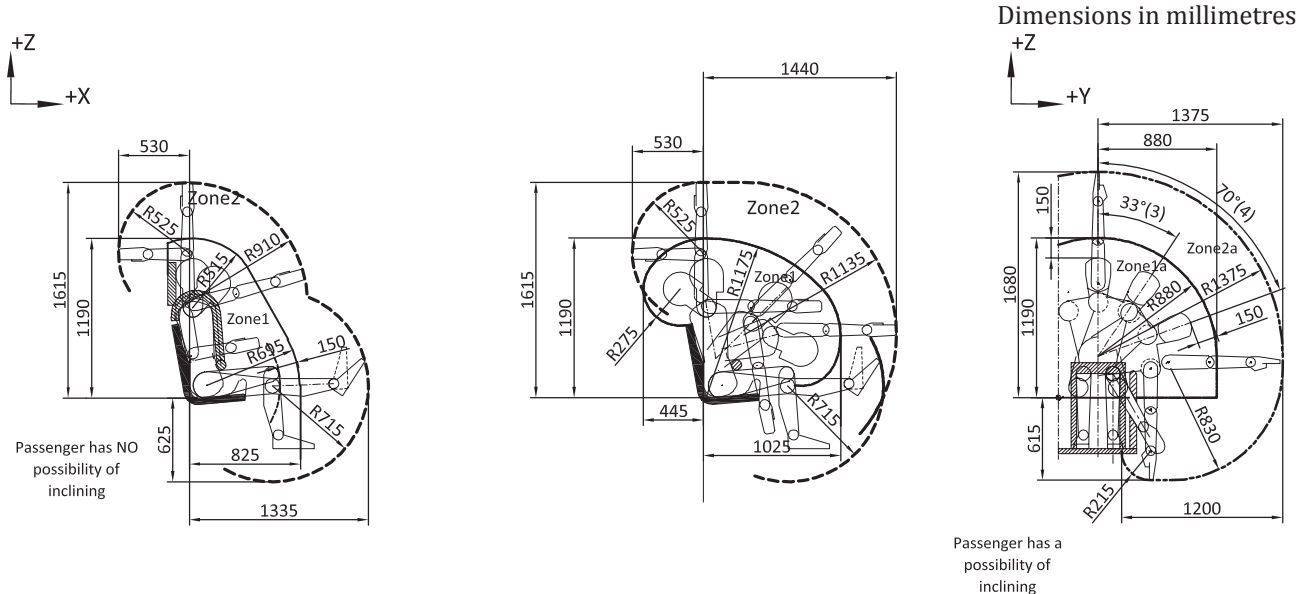
Zone 2a — zone with potential biomechanical risk of low degree at abrupt deceleration (RB-3) — a recommended zone.



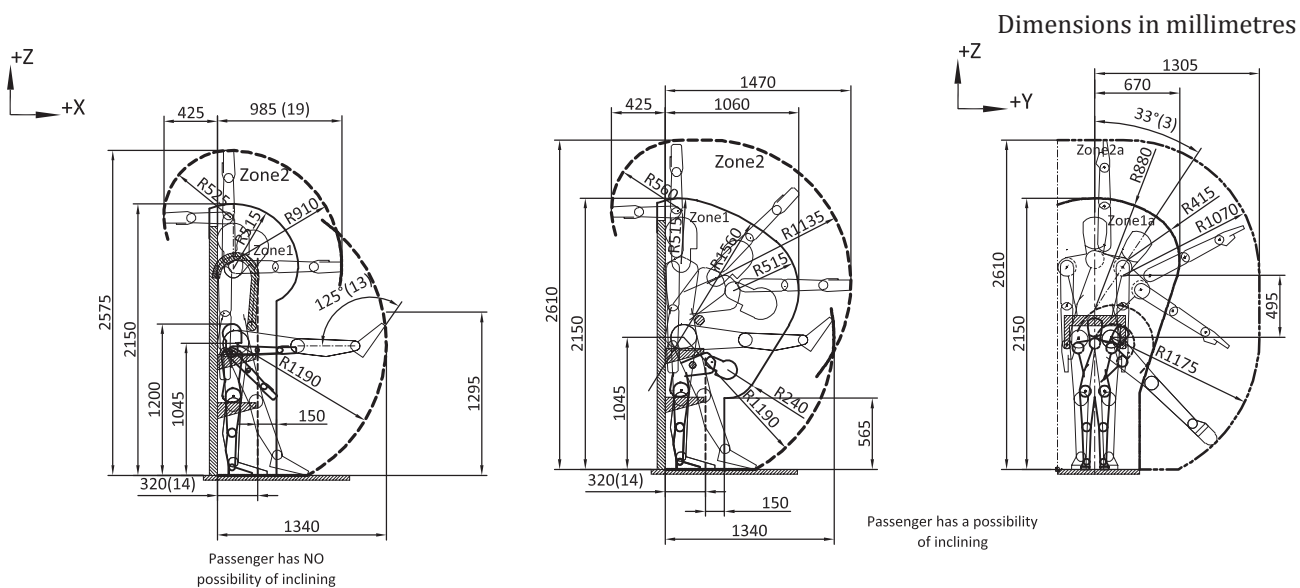
**Figure A.1 — Zone of potential biomechanical risks in reach envelopes for passengers in a sitting position, along x-axis (back and forward)**





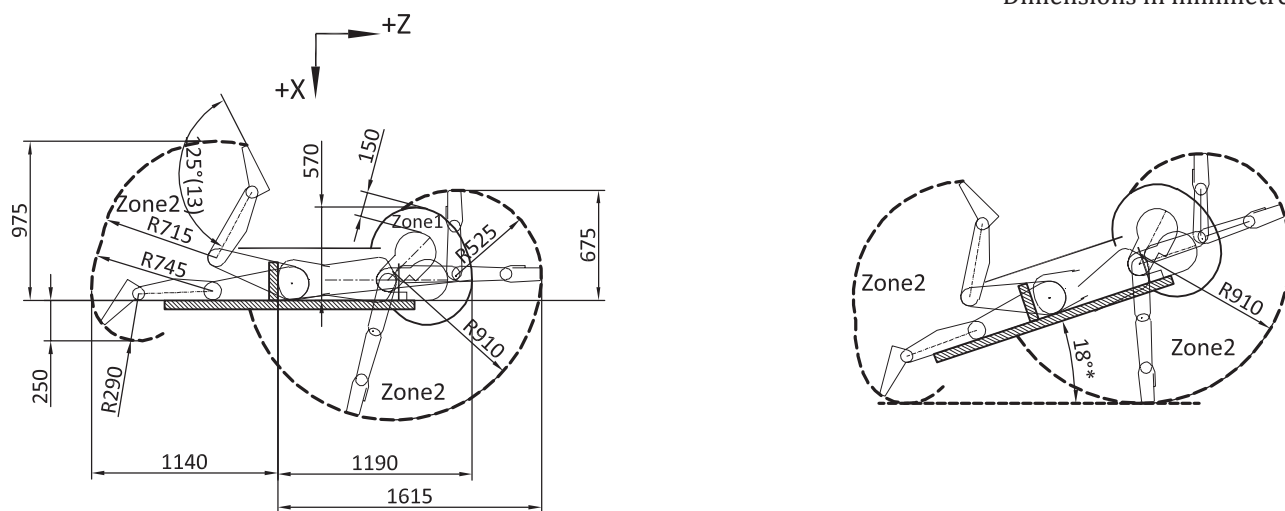


**Figure A.4 — Zone of potential biomechanical risks in reach envelopes for passengers in a sitting position, along y-axis (sideward)**



**Figure A.5 — Zone of potential biomechanical risks in reach envelopes for passengers in a standing position, along y-axis (sideward)**

Dimensions in millimetres



**Figure A.6 — Zone of potential biomechanical risks in reach envelopes for passengers in a prone position, along y-axis (sideward)**

## Annex B (informative)

### Recommended acceleration limits

#### B.1 General

Unfavourable effects of accelerations on the human body may show themselves through the following:

- displacement of the body or its parts under inertia forces, collision with surrounding objects and secondary injuries;
- deformations of tissues and organs resulting in disorders of blood circulation and respiratory disturbance.

Risk of injuries and adverse effects due to accelerations can be minimized by means of the following measures:

- application of appropriate passenger containment and restraint;
- use limitations for persons with physical restriction or health problems;
- application of [Annex B](#) for limiting the accelerations to which passengers are exposed on amusement rides.

Accelerations acting on passengers when using amusement rides should be limited to a tolerable level. Recommended acceleration values given below ensure safety of apparently healthy passengers but some values can cause discomfort, for example, motion sickness.

Limiting values are given below. For the different directions of accelerations the passenger coordinate system with orthogonal axes X, Y, and Z as shown in [Figure B.1](#) applies. The Z-axis direction is defined along the spine ( $\pm 5^\circ$  tolerance).

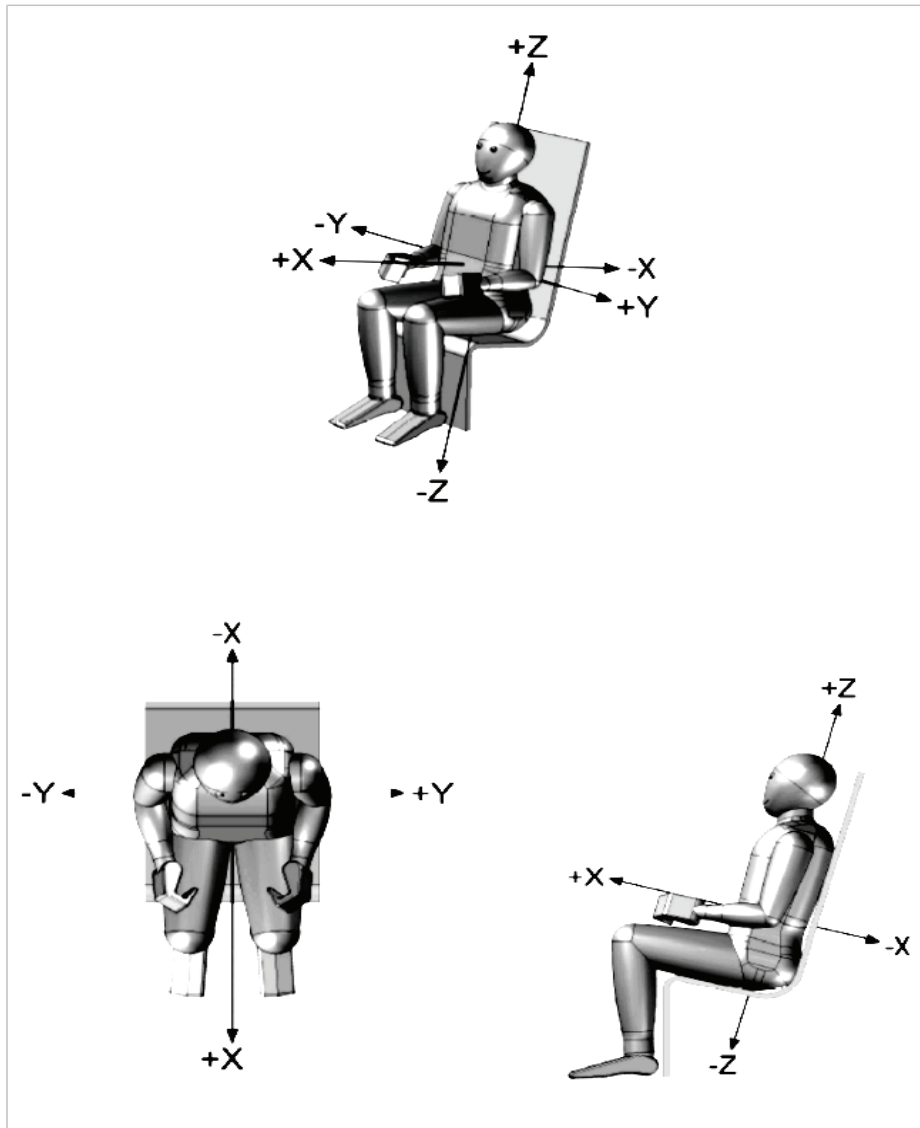


Figure B.1 — Human body coordinate system

## B.2 Rides

### B.2.1 General

All passenger units need to be equipped with suitable seats (with regard to lateral guidance, padding, head rests, etc.) and appropriate restraint devices. The values stated are not applicable for persons with impaired health conditions.

Measurements should be taken according to Reference [30]. The acquired Standardized Amusement Ride Characterization (SARC) test data shall be post-processed with a 4-pole, single pass, Butterworth low pass filter using a frequency of 5 Hz.

The reference point for calculated or measured accelerations is 600 mm above seat-level of the vehicle (SARC-EN test in Reference [30], Chapter 13).

In the design stage, it is recommended that the permissible acceleration values be reduced by a minimum of 10 %.

## B.2.2 General definitions and limitations

### B.2.2.1 Limitations/excluded influences

Accelerations of less than 200 ms duration are not addressed in this Technical Specification.

The limits are for passengers 1,20 m in height and above. Accelerations to passengers with specific physical disabilities are not addressed either; they are assumed to be able to accommodate accelerations subject to all types of passengers.

The steady-state values of accelerations with the duration of more than 40 s and up to 90 s are valid for accelerations acting in X and Y directions.

This Technical Specification does not address a duration of the effect for the steady-state acceleration values with the duration of more than 40 s in Z direction.

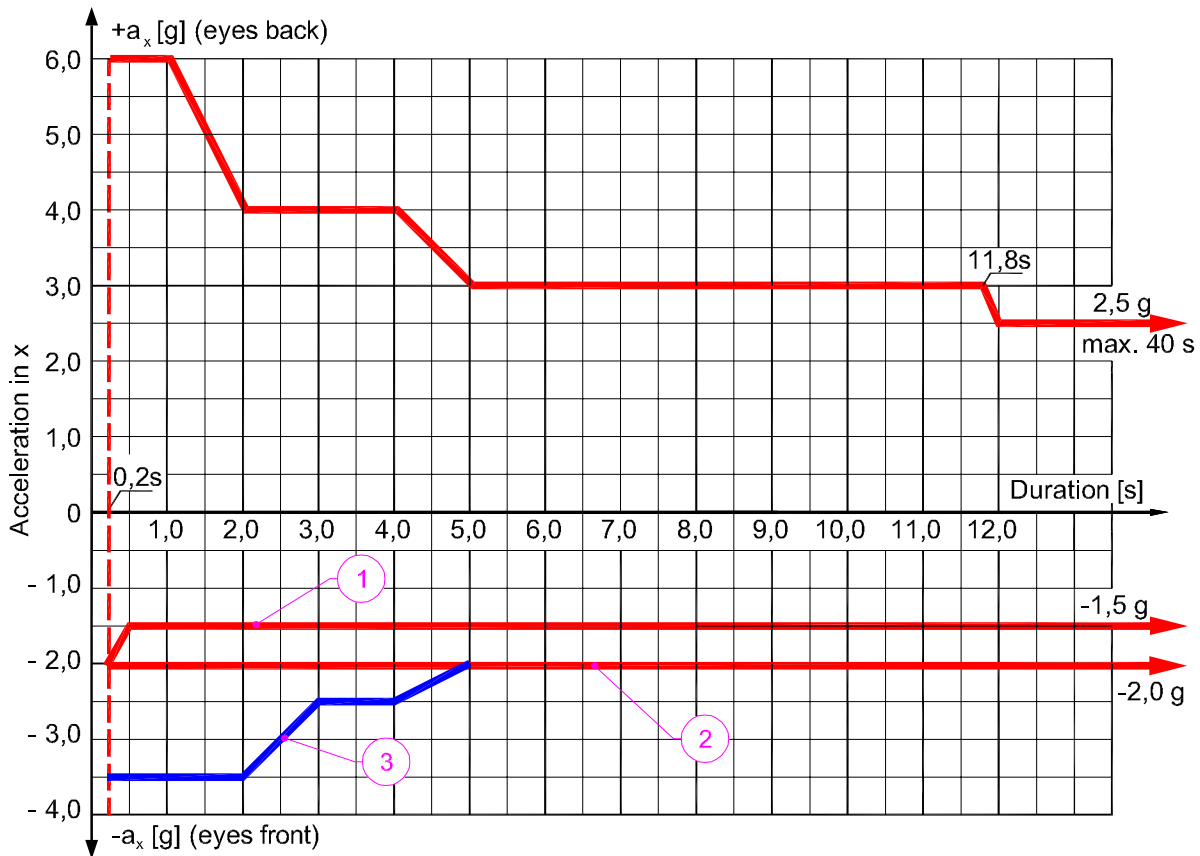
### B.2.2.2 Accelerations

The positive directions of acceleration ( $a_x$ ,  $a_y$ , or  $a_z$ ) are defined in the figures of this annex for the coordinate system as follows:

- $+a_z$  presses the body into the seat downwards, described as “eyes down”;
- $-a_z$  lifts the body out of the seat, described as “eyes up”;
- $+a_y$  presses the body sideward to the right, described as “eyes right”;
- $-a_y$  presses the body sideward to the left, described as “eyes left”;
- $+a_x$  presses the body into the seat backward, described as “eyes in”;
- $-a_x$  pushes the body out of the seat forward, described as “eyes out”.

### B.2.3 Acceleration in X-direction

For measured acceleration versus time graphs, the permissible values in the X-direction according to [Figure B.2](#) shall be observed.



**Key**

- 1 base case
- 2 over the shoulder restraint
- 3 prone restraint

**Figure B.2 — Time duration limits for allowable accelerations in X-direction (perpendicular to spine)**

The total duration of steady-state accelerations should not exceed 40 s.

NOTE 1 Base case is the individual body restraint.

NOTE 2 Over-the-shoulder restraint minimizes passenger forward motion.

NOTE 3 Over-the-shoulder limits are increased to prone limits providing the acceleration onset rate is less than 15 g/s and the restraint is appropriately padded.

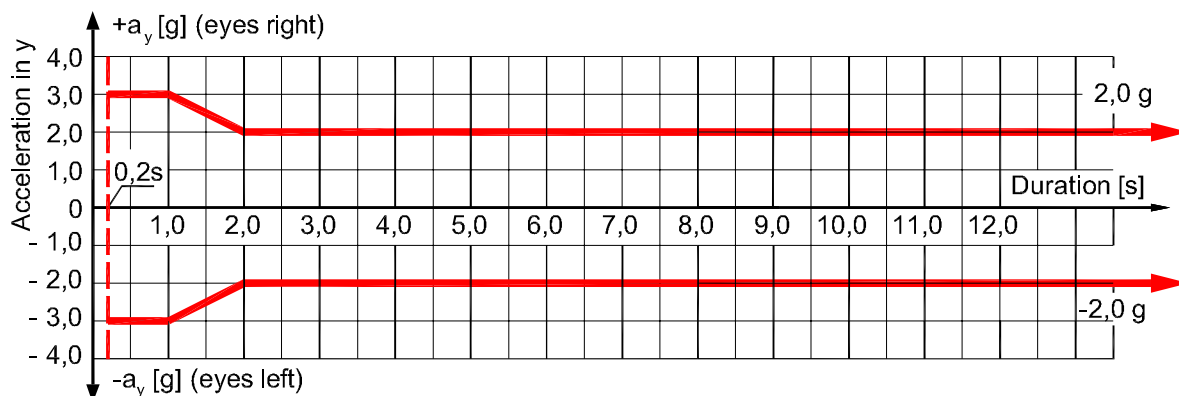
NOTE 4 Prone restraint assumes human body is supported by appropriately padded restraint.

NOTE 5 Acceleration values along +x-axis with the amplitude of 4 g and more are valid for the case where a passenger is in a seat with headrest.

**B.2.4 Acceleration in Y-direction**

For measured acceleration versus time graphs, the permissible values in Y-direction according to [Figure B.3](#) shall be observed.

NOTE Limits in [Figure B.3](#) are valid for a passenger with the pelvis and shoulder restrained.

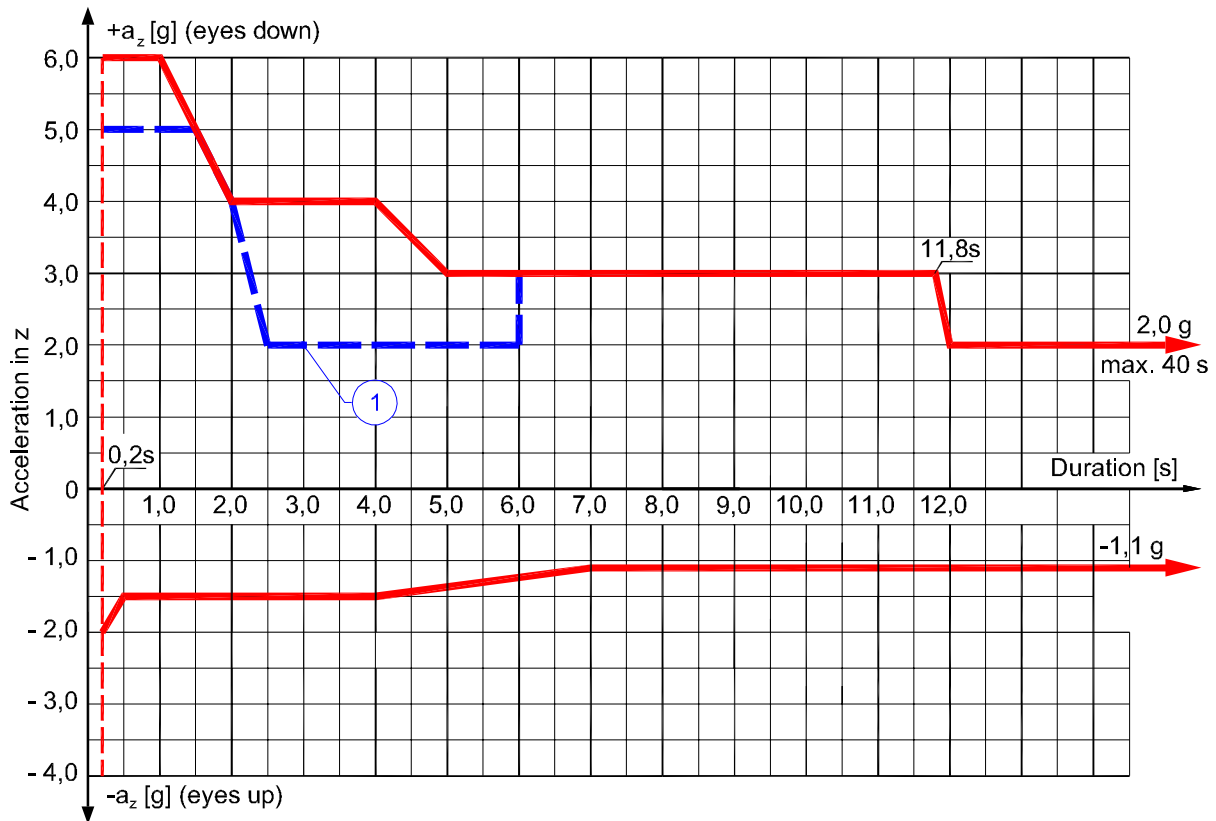


**Figure B.3 — Time duration limits for allowable accelerations in Y-direction**

### B.2.5 Acceleration in Z-direction (parallel to spine)

For measured acceleration versus time graphs, the permissible values in Z-direction according to [Figure B.4](#) shall be observed.





**Key**

- 1 +Gz limits if preceded by 3 s or more of -Gz
- Maximum duration of +a<sub>z</sub> (eyes down) = 2,0 g is limited to 40 s.

**Figure B.4 — Time duration limits for accelerations in Z-direction (parallel to spine)**

**B.2.6 Combinations**

When simultaneous or consecutive a<sub>x</sub>, a<sub>y</sub>, or a<sub>z</sub> acceleration values occur, the combination shall be checked.

Based on the assumption that the graphs are an assembly of elliptical curves, the combined effect of accelerations can be checked for acceptability by using the Formulae (B.1) to (B.3) below:

$$\left(\frac{a_x}{\text{adm } a_x}\right)^2 + \left(\frac{a_y}{\text{adm } a_y}\right)^2 \leq 1,0 \tag{B.1}$$

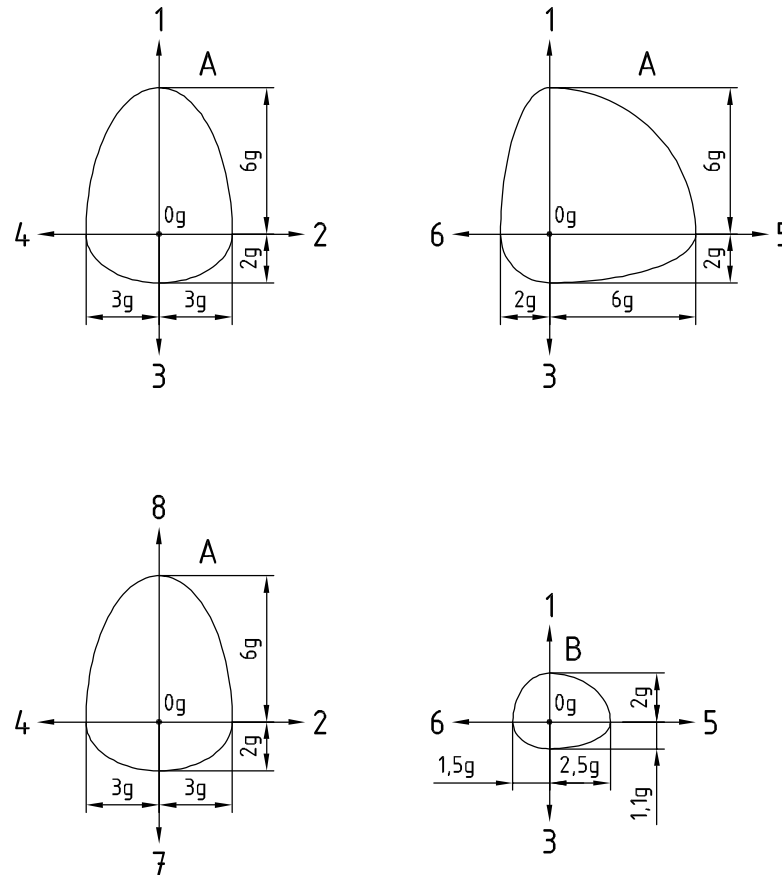
$$\left(\frac{a_x}{\text{adm } a_x}\right)^2 + \left(\frac{a_z}{\text{adm } a_z}\right)^2 \leq 1,0 \tag{B.2}$$

$$\left(\frac{a_z}{\text{adm } a_z}\right)^2 + \left(\frac{a_y}{\text{adm } a_y}\right)^2 \leq 1,0 \tag{B.3}$$

Admissible accelerations (adm a<sub>x</sub>, adm a<sub>y</sub>, or adm a<sub>z</sub>) for selected durations shall be taken from [Figures B.2](#) to [B.4](#).

Where there is a combination of accelerations, in order to keep the passenger's position, appropriate restraints should be provided. Combined accelerations for less than 200 ms are excluded.

[Figure B.5](#) shows some examples of the allowable combined magnitude of X, Y, and Z accelerations. In the graphs, the terms are not divided by adm  $a_x$ , adm  $a_y$  or adm  $a_z$  and the shape is ellipsoid.



**Key**

- A combination for  $t = 0,2$  s
- B combination for  $t > 12$  s
- 1  $+ a_z$  [g] (eyes down)
- 2  $+ a_y$  [g] (eyes right)
- 3  $- a_z$  [g] (eyes up)
- 4  $- a_y$  [g] (eyes left)
- 5  $+ a_x$  [g] (eyes in)
- 6  $- a_x$  [g] (eyes out)
- 7  $- a_x$  [g] (eyes out)
- 8  $+ a_x$  [g] (eyes in)

**Figure B.5 — Examples of allowable combined magnitudes of  $a_x$ ,  $a_y$ , and  $a_z$  accelerations**

## **Annex C** (informative)

### **Hazard of passengers being held in an upside-down position in emergency**

The amount of time that passengers are held in an upside-down position should be limited.

The ride designers should consider this possibility in the design risk assessment and take steps to mitigate through operational preparedness.

## Annex D (informative)

### Use of amusement rides considering the state of health or well-being of passengers — Warning signs to advise passengers

The use of amusement rides is recommended only for those who are feeling well. In order to avoid potential incidents when riding, it is advisable that rules, recommendations and advice for use be displayed at the entrance to each amusement ride.

With some health or well-being deviations from the norm, amusement rides may cause harm. Therefore, the designer or the controller of a ride can introduce use limitations for groups such as pregnant women, or people with cardiovascular diseases, disorders of musculoskeletal system and/or neuropsychic disorders.

Dizziness and nausea may be caused by carousels, roundabouts, swings, and other amusement rides which feature repeated rotational motion or revolutions, flashing or flickering lights, etc., notably in people having weak vestibular systems, individuals suffering from exhaustion or who are under the influence of alcohol or drugs. Amusement rides on which passengers are exposed to high accelerations may cause injury to people who have diseases or disorders of the musculoskeletal or cardiovascular system, to pregnant women, or those under the influence of alcohol or drugs.

Appropriate warning signs should be placed to warn the passengers of the potential harm.

The ride operator will not always be able to determine the condition of a guest and to prevent him or her from riding. Relevant warnings displayed at amusement rides place the responsibility for using an amusement ride while in poor health or under the influence of alcohol or drugs on the passenger.

Amusement rides which should not be used by the above groups, others in poor health or guests who are simply not feeling well should be fitted with appropriate warning signs. It is advisable to display these warnings next to the rules of behaviour for the passengers of an amusement ride.

Examples of prohibition safety signs for pregnant women and for people under the influence of alcohol, drugs or medicines are shown in [Figures D.1](#) and [D.2](#). These signs were still undergoing the ISO graphical symbol registration process at the time of publication of this Technical Specification. Others may be developed, but only registered signs and symbols should be used.

NOTE See the ISO Online Browsing Platform (OBP) for the collection of existing registered signs and symbols: <https://www.iso.org/obp/ui/>. Refer to ISO 9186-1 for testing the effectiveness of proposed symbols.



Figure D.1 — Ride not to be used by pregnant women



**Figure D.2 — Ride not to be used while under the influence of alcohol, drugs or medicines**

## Bibliography

- [1] *Aerospace medicine (Aviation safety problems)*. Ed. Gyurdzhian A.A. Moscow, 1975
- [2] Analysis of design diagrams for tolerance to g-loads acting on a passenger of amusement ride “Magic Steed” and report for compliance with OST and biomechanical and physiological/hygienic requirements for amusement ride “Roller Coaster”. Moscow, 1990
- [3] Analysis of injury rate with respect to falls of people from heights in emergencies. Technical Report of RAAPA, Moscow 2011
- [4] BARER A.S. Problems of accelerations in space physiology. *Space biology and medicine* 1967 №1
- [5] DIN 334081:2008, *Body templates - Part 1: For seats of all kinds*
- [6] GODLEVSKA M.A. *Aging changes of mechanical properties of cerebral arteries (experimental data)/ Biomechanics/ Proceedings of Riga’s institute of traumatology and orthopaedy. is. XIII, 1975*
- [7] ERNSTING J. Ed. *Aviation medicine /Physiology and Human Factors/* London. 1978.
- [8] GOST 12.2.049:1980, *Occupational safety standards system. Industrial equipment. General ergonomic requirements*
- [9] GOST R 53130:2008 *Safety of amusement rides. General requirements*. M. 2009
- [10] IEC 60812:2006, *Analysis techniques for system reliability — Procedure for failure mode and effects analysis (FMEA)*
- [11] KOTOVSKAYA A.R., WIL-WILLIAMS I.F., LUKYANYUK V. Yu. Tolerance to G-loads +Gz by persons of different ages with non-flight occupations. *Space biology and medicine*. 1986. № 4. p. 25
- [12] LUKYANYUK V.Yu. G-load (+Gz) tolerance by persons from 41 to 58 years old. *Space biology and medicine*. 1984. № 5. p. 18.
- [13] RABINOVICH B.A. *Human safety under acceleration (biomechanical analysis)*. M. 2007.
- [14] Report No. 245-87-89 with results of preliminary full-scale assessment of amusement ride “Roller Coaster”.1989
- [15] Report No. 246-87-89 with results of full-scale physiological and hygienic assessment of amusement ride “Roller Coaster”. 1989
- [16] Report with results of physiological studies on centrifuge for tolerance to g-loads inherent to amusement ride “Roller Coaster”. 1989
- [17] Scientific and technical report. Biomechanical and physiological/hygienic assessment of exposure related to use of amusement ride “Roller Coaster” . V.ALYAPIN et al, Moscow 1989
- [18] SERGEEV A.A. Physiological mechanism of acceleration action
- [19] Statement for allowable G-loads of “head-to-pelvis” or “pelvis-to-head” direction intended for inclusion in the draft ISO standard “Biomechanical effects on amusement ride passengers”, Prof. R.AVARTBARONOV 10.01.2013
- [20] STOLL A.M. Human tolerance to positive G as determined by the physiological end-points. *Av. Med.* 1956, **27** (4) p. 356
- [21] SUVOROV P.M. Influence of age, occupation and physical training on human tolerance of long-term g-loads. *Space biology and medicine*. 1968. № 6. p. 62.

- [22] VASILYEV P.V., & KOTOVSKAYA A.R. Prolonged linear and radial accelerations. Fundamentals of space biology and medicine 1975 v.2. book 1, p.117
- [23] Addition No. 1 to Statement [19], Prof. R.AVARTBARONOV 22.01.2013
- [24] World Health Organization (WHO): Global Database on Body Mass Index
- [25] KOTOVSKAYA A.R., & VARTBARONOV R.A. Long-time linear accelerations. Man in space flight. (Space biology and medicine). M.: Nauka, 1997, volume III, book 2, chapter 13, p.10-67
- [26] VARTBARONOV R.A. et al. Sportsmen pilots' tolerance to aerobic g-loads on Su-26 aircraft. Aerospace and ecological medicine 1993. No. 5-6.
- [27] VOLOSHIN V.G. et al. Characteristic of g-loads at sport flying for aerobatics. Space biology and aerospace medicine. 1985, No.5; 1988, No.5
- [28] PETRUKHIN V.G., & MARKARYAN S.S. *Pathomorphological changes under radial accelerations acting in the "head-to-feet" direction. Problems of space biology and medicine. M. Nauka, 1967*
- [29] RABINOVICH B.A. About possible causes of headache at multiple rides on the roller coaster. Parks and clubs. 2000, No. 1
- [30] ASTM F2137, *Standard Practice for Measuring the Dynamic Characteristics of Amusement Rides and Devices*
- [31] ISO 2631-4, *Mechanical vibration and shock — Evaluation of human exposure to whole-body vibration — Part 4: Guidelines for the evaluation of the effects of vibration and rotational motion on passenger and crew comfort in fixed-guideway transport systems*
- [32] ISO 9186-1, *Graphical symbols — Test methods — Part 1: Method for testing comprehensibility*
- [33] ISO 12100, *Safety of machinery — General principles for design — Risk assessment and risk reduction*
- [34] ISO 15534-3, *Ergonomic design for the safety of machinery — Part 3: Anthropometric data*
- [35] ISO/TR 7250-2, *Basic human body measurements for technological design — Part 2: Statistical summaries of body measurements from national populations*







# British Standards Institution (BSI)

BSI is the national body responsible for preparing British Standards and other standards-related publications, information and services.

BSI is incorporated by Royal Charter. British Standards and other standardization products are published by BSI Standards Limited.

## About us

We bring together business, industry, government, consumers, innovators and others to shape their combined experience and expertise into standards-based solutions.

The knowledge embodied in our standards has been carefully assembled in a dependable format and refined through our open consultation process. Organizations of all sizes and across all sectors choose standards to help them achieve their goals.

## Information on standards

We can provide you with the knowledge that your organization needs to succeed. Find out more about British Standards by visiting our website at [bsigroup.com/standards](http://bsigroup.com/standards) or contacting our Customer Services team or Knowledge Centre.

## Buying standards

You can buy and download PDF versions of BSI publications, including British and adopted European and international standards, through our website at [bsigroup.com/shop](http://bsigroup.com/shop), where hard copies can also be purchased.

If you need international and foreign standards from other Standards Development Organizations, hard copies can be ordered from our Customer Services team.

## Subscriptions

Our range of subscription services are designed to make using standards easier for you. For further information on our subscription products go to [bsigroup.com/subscriptions](http://bsigroup.com/subscriptions).

With **British Standards Online (BSOL)** you'll have instant access to over 55,000 British and adopted European and international standards from your desktop. It's available 24/7 and is refreshed daily so you'll always be up to date.

You can keep in touch with standards developments and receive substantial discounts on the purchase price of standards, both in single copy and subscription format, by becoming a **BSI Subscribing Member**.

**PLUS** is an updating service exclusive to BSI Subscribing Members. You will automatically receive the latest hard copy of your standards when they're revised or replaced.

To find out more about becoming a BSI Subscribing Member and the benefits of membership, please visit [bsigroup.com/shop](http://bsigroup.com/shop).

With a **Multi-User Network Licence (MUNL)** you are able to host standards publications on your intranet. Licences can cover as few or as many users as you wish. With updates supplied as soon as they're available, you can be sure your documentation is current. For further information, email [bsmusales@bsigroup.com](mailto:bsmusales@bsigroup.com).

## BSI Group Headquarters

389 Chiswick High Road London W4 4AL UK

## Revisions

Our British Standards and other publications are updated by amendment or revision.

We continually improve the quality of our products and services to benefit your business. If you find an inaccuracy or ambiguity within a British Standard or other BSI publication please inform the Knowledge Centre.

## Copyright

All the data, software and documentation set out in all British Standards and other BSI publications are the property of and copyrighted by BSI, or some person or entity that owns copyright in the information used (such as the international standardization bodies) and has formally licensed such information to BSI for commercial publication and use. Except as permitted under the Copyright, Designs and Patents Act 1988 no extract may be reproduced, stored in a retrieval system or transmitted in any form or by any means – electronic, photocopying, recording or otherwise – without prior written permission from BSI. Details and advice can be obtained from the Copyright & Licensing Department.

## Useful Contacts:

### Customer Services

**Tel:** +44 845 086 9001

**Email (orders):** [orders@bsigroup.com](mailto:orders@bsigroup.com)

**Email (enquiries):** [cservices@bsigroup.com](mailto:cservices@bsigroup.com)

### Subscriptions

**Tel:** +44 845 086 9001

**Email:** [subscriptions@bsigroup.com](mailto:subscriptions@bsigroup.com)

### Knowledge Centre

**Tel:** +44 20 8996 7004

**Email:** [knowledgecentre@bsigroup.com](mailto:knowledgecentre@bsigroup.com)

### Copyright & Licensing

**Tel:** +44 20 8996 7070

**Email:** [copyright@bsigroup.com](mailto:copyright@bsigroup.com)



...making excellence a habit.™