

PD ISO/TS 17863:2013



BSI Standards Publication

# Geometrical product specification (GPS) — Geometrical tolerancing of moveable assemblies

**bsi.**

...making excellence a habit.™

**National foreword**

This Published Document is the UK implementation of ISO/TS 17863:2013.

The UK participation in its preparation was entrusted to Technical Committee TDW/4, Technical Product Realization.

A list of organizations represented on this committee can be obtained on request to its secretary.

This publication does not purport to include all the necessary provisions of a contract. Users are responsible for its correct application.

© The British Standards Institution 2013. Published by BSI Standards Limited 2013

ISBN 978 0 580 78867 3

ICS 17.040.01

**Compliance with a British Standard cannot confer immunity from legal obligations.**

This Published Document was published under the authority of the Standards Policy and Strategy Committee on 30 June 2013.

**Amendments issued since publication**

Date	Text affected
------	---------------

---

**TECHNICAL  
SPECIFICATION**

**ISO/TS  
17863**

First edition  
2013-05-01

---

---

**Geometrical product specification  
(GPS) — Geometrical tolerancing of  
moveable assemblies**

*Spécification géométrique des produits (GPS) — Tolérancement  
géométrique des assemblages mobiles*



Reference number  
ISO/TS 17863:2013(E)

© ISO 2013



**COPYRIGHT PROTECTED DOCUMENT**

© ISO 2013

All rights reserved. Unless otherwise specified, no part of this publication may be reproduced or utilized otherwise in any form or by any means, electronic or mechanical, including photocopying, or posting on the internet or an intranet, without prior written permission. Permission can be requested from either ISO at the address below or ISO's member body in the country of the requester.

ISO copyright office  
Case postale 56 • CH-1211 Geneva 20  
Tel. + 41 22 749 01 11  
Fax + 41 22 749 09 47  
E-mail [copyright@iso.org](mailto:copyright@iso.org)  
Web [www.iso.org](http://www.iso.org)

Published in Switzerland

# Contents

Page

<b>Foreword</b> .....	<b>iv</b>
<b>Introduction</b> .....	<b>v</b>
<b>1 Scope</b> .....	<b>1</b>
<b>2 Normative references</b> .....	<b>1</b>
<b>3 Terms and definitions</b> .....	<b>1</b>
<b>4 Symbols</b> .....	<b>1</b>
<b>5 General concept</b> .....	<b>2</b>
<b>6 Graphical language</b> .....	<b>3</b>
6.1 Indication of item references.....	3
6.2 Force indicator.....	3
6.3 Indication of direction of gravity.....	4
6.4 Connection of force indicator with concerned feature.....	5
6.5 Application of force on portions of a feature.....	6
6.6 Direction of force.....	7
6.7 Indication of direction of mobility.....	8
6.8 Indication of interrelation of tolerance indication and conditions.....	9
6.9 Description of conditions.....	10
6.10 List and sequence of conditions.....	10
<b>Annex A (normative) Relations and dimensions of graphical symbols</b> .....	<b>12</b>
<b>Annex B (informative) Example of run-out and size tolerances on a tapered roller bearing</b> .....	<b>14</b>
<b>Annex C (informative) Relation to the GPS matrix model</b> .....	<b>15</b>
<b>Bibliography</b> .....	<b>17</b>

## Foreword

ISO (the International Organization for Standardization) is a worldwide federation of national standards bodies (ISO member bodies). The work of preparing International Standards is normally carried out through ISO technical committees. Each member body interested in a subject for which a technical committee has been established has the right to be represented on that committee. International organizations, governmental and non-governmental, in liaison with ISO, also take part in the work. ISO collaborates closely with the International Electrotechnical Commission (IEC) on all matters of electrotechnical standardization.

The procedures used to develop this document and those intended for its further maintenance are described in the ISO/IEC Directives, Part 1. In particular the different approval criteria needed for the different types of ISO documents should be noted. This document was drafted in accordance with the editorial rules of the ISO/IEC Directives, Part 2. [www.iso.org/directives](http://www.iso.org/directives)

Attention is drawn to the possibility that some of the elements of this document may be the subject of patent rights. ISO shall not be held responsible for identifying any or all such patent rights. Details of any patent rights identified during the development of the document will be in the Introduction and/or on the ISO list of patent declarations received. [www.iso.org/patents](http://www.iso.org/patents)

Any trade name used in this document is information given for the convenience of users and does not constitute an endorsement.

The committee responsible for this document is ISO/TC 213, *Dimensional and geometrical product specifications and verification*.

## Introduction

This Technical Specification is a geometrical product specification (GPS) standard and is to be regarded as a general GPS standard (see ISO/TR 14638). It influences chain links 1 to 3 of the chain of standards on size, distance, angle, form of line dependent on datum, form of surface dependent on datum, orientation, location, circular run-out, total run-out and datums.

The ISO/GPS Masterplan given in ISO/TR 14638 gives an overview of the ISO/GPS system of which this document is a part. The fundamental rules of ISO/GPS given in ISO 8015 apply to this document and the default decision rules given in ISO 14253-1 apply to specifications made in accordance with this document, unless otherwise indicated.

For more detailed information of the relation of this Technical Specification to other standards and the GPS matrix model, see [Annex C](#).

ISO 1101 cannot be applied on movable assemblies where one part of the assembly includes tolerance indications and another part includes corresponding datum indications, because there is a specification uncertainty due to undefined conditions of the interaction and relative mobility of the parts and how the parts are kept together.

ISO 14405-1 cannot be applied on movable assemblies, because there is a specification uncertainty due to undefined conditions of the interaction and relative mobility of the parts and how the parts are kept together.

This Technical Specification provides additional GPS symbols for indication of constraint conditions, e.g. application of forces.





# Geometrical product specification (GPS) — Geometrical tolerancing of moveable assemblies

## 1 Scope

This Technical Specification specifies the indication of constraint conditions in between the parts of moveable assemblies in conjunction with tolerancing according to ISO GPS standards. On geometrical tolerancing, one part of the assembly includes tolerance indications and another part includes corresponding datum indications.

## 2 Normative references

The following documents, in whole or in part, are normatively referenced in this document and are indispensable for its application. For dated references, only the edition cited applies. For undated references, the latest edition of the referenced document (including any amendments) applies.

ISO 128-24, *Technical drawings — General principles of presentation — Part 24: Lines on mechanical engineering drawings*

ISO 1101:2012, *Geometrical product specifications (GPS) — Geometrical tolerancing — Tolerances of form, orientation, location and run-out*

ISO 6433:2012, *Technical product documentation — Part references*

ISO 14405-1:2010, *Geometrical product specifications (GPS) — Dimensional tolerancing — Part 1: Linear sizes*

ISO 81714-1, *Design of graphical symbols for use in the technical documentation of products — Part 1: Basic rules*

## 3 Terms and definitions

For the purpose of this document, the terms and definitions given in ISO 1101, ISO 14405-1 and the following apply.

### 3.1

#### **movable assembly**

assembly of two or more parts where the parts can be moved relative to each other

## 4 Symbols

For the purpose of this document, the symbols in [Table 1](#) apply.

Rules for the presentation of graphical symbols are given in [Annex A](#).

Table 1 — Symbols for movable assemblies

Description	Symbol	Remark	Reference
Force indicator		a	<a href="#">6.2</a>
Force indicator including basic indication of specific direction of the force relative to a single datum		a, b	<a href="#">6.2</a>
Force indicator including basic indication of specific direction of the force relative to a datum system	 	a, b	<a href="#">6.2</a>
Complementary force indicator		a	<a href="#">6.6</a>
Gravity	 	c	<a href="#">6.3</a>
Mobility – translational			<a href="#">6.7</a>
Mobility – rotational			<a href="#">6.7</a>
Flag		a	<a href="#">6.8</a> and <a href="#">6.9</a>
Movable part	MP		<a href="#">6.10.1.1</a>
Fixed part	FP		<a href="#">6.10.1.1</a>
Translational mobility in positive direction	T+		<a href="#">6.10.1.2</a>
Translational mobility in negative direction	T-		<a href="#">6.10.1.2</a>
Rotational mobility in positive direction	R+		<a href="#">6.10.1.2</a>
Rotational mobility in negative direction	R-		<a href="#">6.10.1.2</a>
<p>a Number 1 in F1 is an example for numbering of different forces.</p> <p>b Symbol <math>\angle</math> is an example. Symbols <math>//</math>, <math>\perp</math>, and <math>\equiv</math> may be used as well.</p> <p>c Number 1 in G1 is an example for numbering of different direction of gravity.</p> <p>d Number 1 is an example for numbering of different flags.</p>			

## 5 General concept

All degrees of freedom that are not necessary for the concerned tolerated characteristic shall be locked.

EXAMPLE 1 For circular run-out, all translational degrees of freedom and two rotational degrees of freedom are locked. Only the third rotational degree of freedom, i.e. the one which is relevant to rotate the part relative to the datum, is kept unlocked.

Per default, the part with tolerance indications is considered as a movable part and the part with datum indications is considered as a fixed part.

Movable and fixed parts shall be numbered with item references according to ISO 6433. This shall be used in the descriptions of the conditions to specify which part is movable and which part is fixed.

Locking degrees of freedom shall be realized by application of forces (which can also be only the force of gravity) as applied in the real application of the movable assembly. Per default, the force is evenly distributed at the complete concerned integral feature, but can be limited to portions of the integral feature and/or contacting features. If the force is applied on a portion of an integral feature, the force is also evenly distributed. If the force is applied on more than one portion of an integral feature, the force

is evenly distributed to all portions. If the force is applied on more than one contacting feature, the force is evenly distributed to all contacting features.

Force shall be applied on the movable part, but might be applied on the fixed part as well in order to keep a stable location of the fixed part relative to the movable part.

**EXAMPLE 2** Force by means of interference fit on a datum feature on a shaft.

Per default, the direction of the force is perpendicular to the concerned feature if not otherwise indicated.

The direction of the mobility shall be indicated on the movable part whenever mobility is possible in different directions and if there is a difference on the behaviour of the assembly dependent on the direction of the mobility.

The tolerance value for the tolerated characteristic is valid under constraint conditions which are invoked by the symbol flag. The detailed description of the conditions shall be given near the title box of the drawing.

There can be different tolerance values for the same characteristic, but valid under different conditions, e.g. real application versus test conditions.

Values for forces and other additional constraint conditions, which are needed to describe the mobility of the movable part against the fixed part, shall be specified by means of descriptions near the title box of the drawing.

## 6 Graphical language

### 6.1 Indication of item references

Item references shall be indicated according to ISO 6433. See [Figure 1](#).

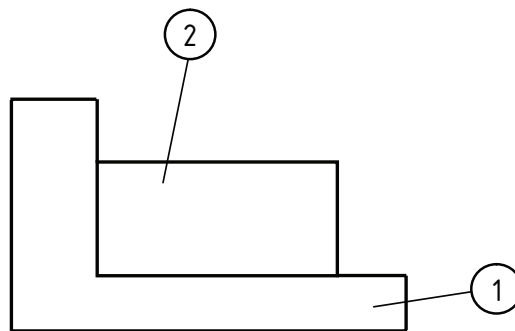

**Figure 1 — Example of item references indication**

### 6.2 Force indicator

The force indicator includes up to five compartments, i.e.

- the utmost left compartment to indicate letter F for force and an adjacent figure to number different forces;
- the subsequent compartment including symbol  $\angle$ ,  $//$ ,  $\perp$  or  $\equiv$  to basically indicate a specific direction of the force;
- the subsequent compartment(s) including letter(s) denominating a datum feature for the indication of a specific direction.

See [Figure 2](#).

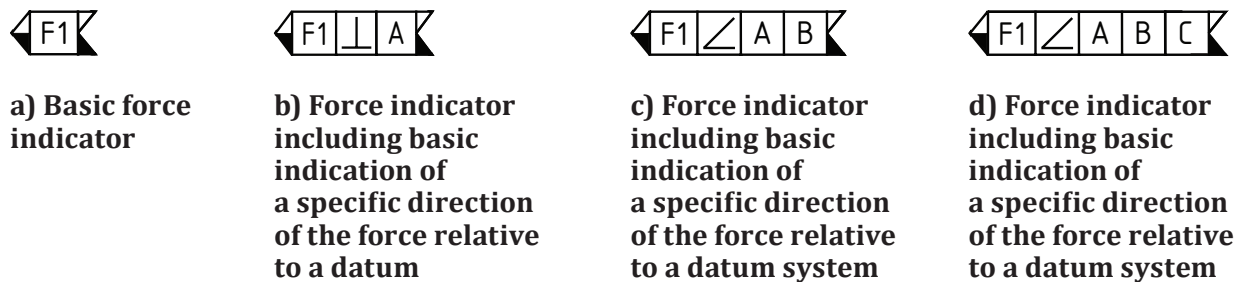
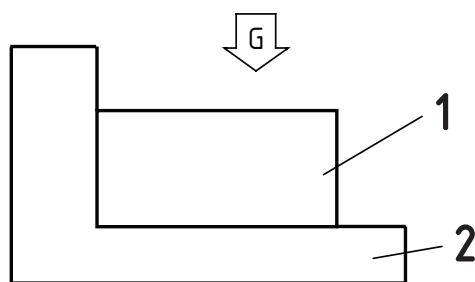

Figure 2 — Examples of force indicators

### 6.3 Indication of direction of gravity

When only the force of gravity is acting on the movable part, the gravity symbol shall be indicated near to the concerned part. The symbol consists of an unfilled arrow including letter G for gravity.

See [Figure 3](#).



**Key**

- 1 movable part
- 2 fixed part

Figure 3 — Indication of the gravity symbol

When the assembly is orientated in adjacent parts in a direction which is not equal to the orientation of the assembly on the assembly drawing, the gravity symbol on the assembly drawing shall be combined with corresponding indications for the orientation.

Single datums, common datums, datum systems and/or orientation planes shall be indicated to orientate the vector.

See [Figure 4](#).

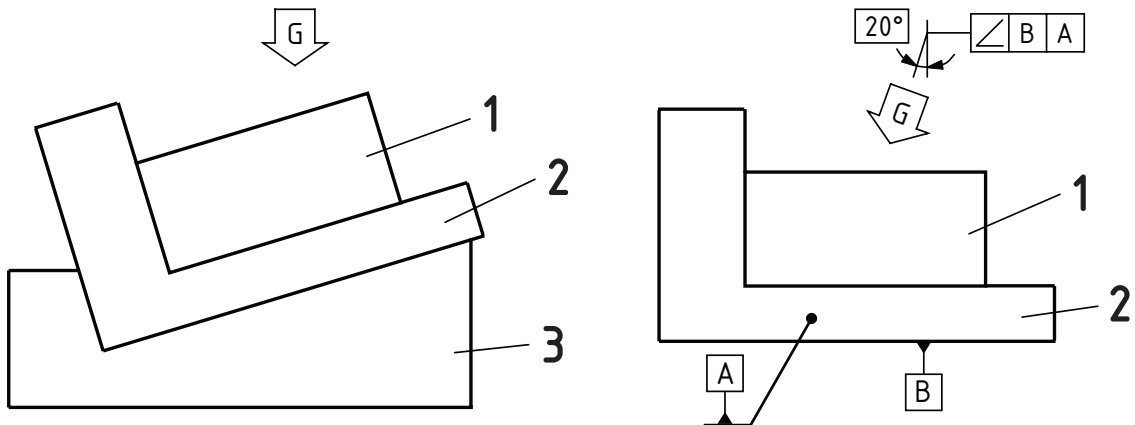

a) Direction of gravity on drawing of assembly and adjacent part      b) Direction of gravity on assembly drawing

**Key**

- |   |              |     |               |
|---|--------------|-----|---------------|
| 1 | movable part | 1+2 | assembly      |
| 2 | fixed part   | 3   | adjacent part |

**Figure 4 — Example of indication of inclined direction of gravity on the assembly drawing**

If the direction of gravity is different for different force applications, different G symbols supplemented by letter G and a related number shall be indicated.

**6.4 Connection of force indicator with concerned feature**

The tolerance indicator shall be connected through a reference and a leader line with the concerned feature.

When the complete or a restricted area of the integral feature is concerned, the leader line shall be terminated with an arrow or a dot/open circle. See [Figures 5](#) and [7](#).

When a line of the integral feature is concerned, the leader line shall be terminated with an arrow. See [Figure 7](#).

When the concerned feature is visible, the leader line shall be continuous and terminated with a dot. When the concerned feature is hidden, the leader line shall be dashed and the leader line shall be terminated with an open circle. See [Figure 5](#).

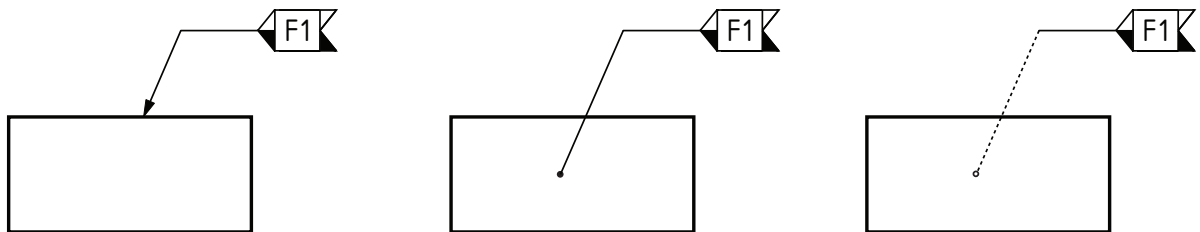

a) Leader line terminated with an arrow      b) Leader line terminated with a dot on a visible feature      c) Leader line terminated with an open circle on a hidden feature

**Figure 5 — Connection of force indicator with concerned feature**

Contacting features may be used in between the force indicator and the concerned feature in order to represent specific contacts. The contacting feature shall be drawn with long-dashed double-dotted narrow lines (type 05.1 of ISO 128-24) and dimensioned with TEDs (theoretical exact dimensions).

See [Figure 6](#).

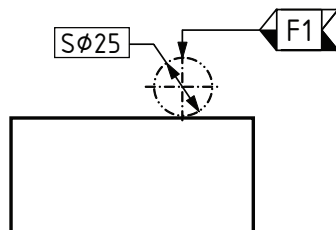

Figure 6 — Example of a contacting feature

### 6.5 Application of force on portions of a feature

If the application of the force is restricted to a point, a cross shall be indicated and dimensioned with TEDs.

If the application of force is restricted to a line, a long-dashed narrow line (type 05.1 of ISO 128-24) shall be indicated, which, when the line is not closed, is terminated by two crosses. This line may be straight, circular or a line of any shape. The line shall be dimensioned with TEDs.

If the application of the force is restricted to an area, this shall be indicated as hatched area surrounded by long-dashed double-dotted narrow lines (type 05.1 of ISO 128-24) and dimensioned with TEDs.

For determination of the exact position of a point, a line or an area, a datum system shall be indicated.

See [Figure 7](#).

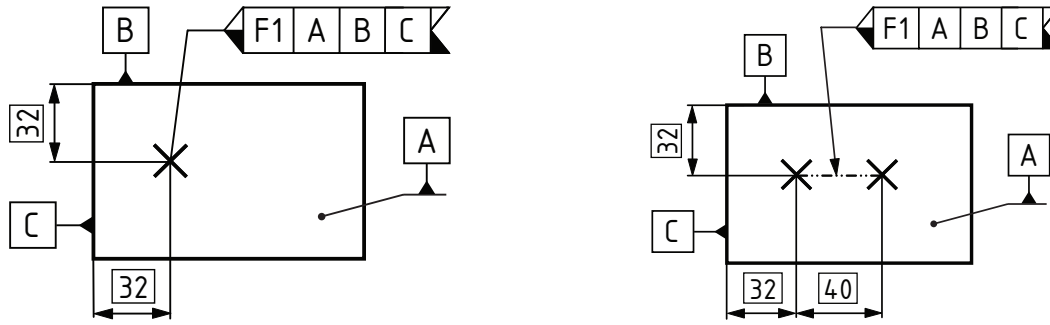

a) Application of the force is restricted to a point      b) Application of the force is restricted to a line

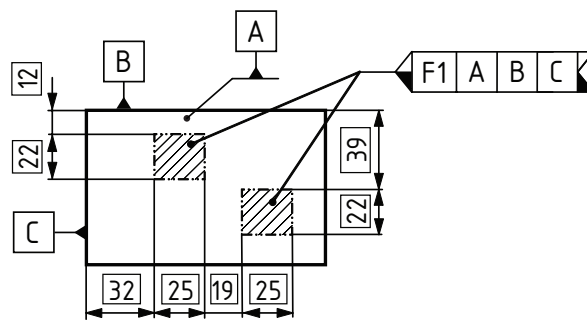

c) Application of the force is restricted to two areas

**Figure 7 — Examples of application of the force on portions of an integral feature**

## 6.6 Direction of force

By default, the direction of force is perpendicular to the concerned feature independent of the direction of the leader line according to [6.3](#).

Specific directions of force shall be specified by

- application of force indicator including symbol  $\angle$ ,  $//$ ,  $\perp$  or  $\equiv$ ;
- indication of TEDs (theoretical exact dimensions) with regard to the concerned feature.

Single datums, common datums, datum systems and/or orientation planes shall be indicated to orientate the vector.

See [Figure 8](#).

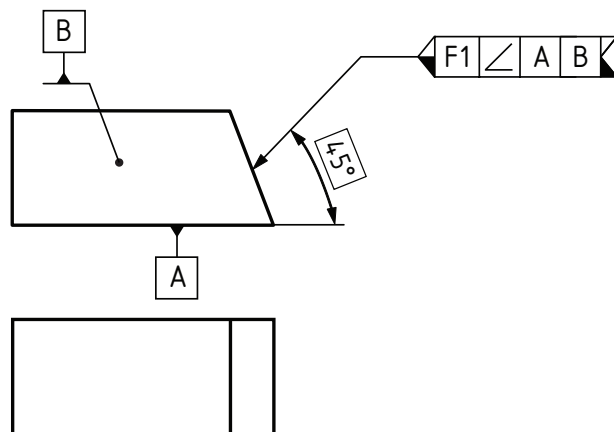

**Figure 8 — Example of indication of specific direction of force without complementary force indicator**

If the direction of the force cannot be indicated unambiguously in one drawing view, a complementary force indicator shall be indicated in another view.

See [Figure 9](#).

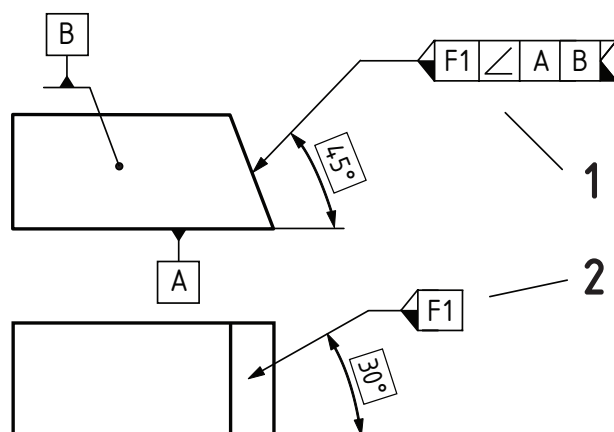

**Key**

- 1 basic force indicator
- 2 complementary force indicator

**Figure 9 — Example of indication of specific direction of force with additional complementary force indicator**

**6.7 Indication of direction of mobility**

The direction of mobility shall be indicated on the assembly drawing.

The arrow head of the mobility symbol shall point in positive direction of the mobility.

See [Figure 10](#).

On symmetrical parts, it is recommended to physically sign the symbol mobility on the product to ensure repeatability of measurements.



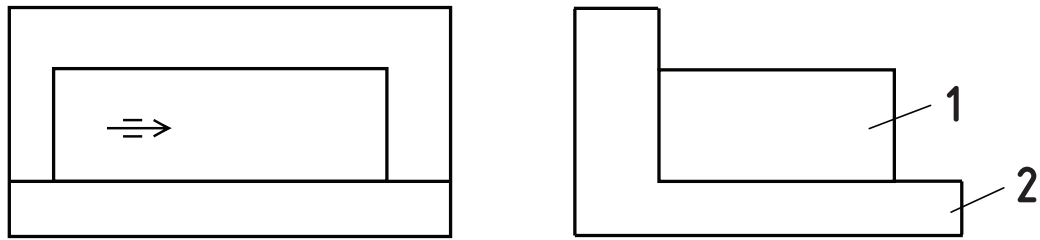

a) Indication of direction of translational mobility

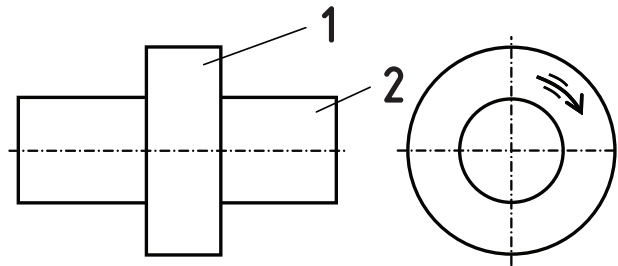

b) Indication of direction of rotational mobility

**Key**

- 1 movable part
- 2 fixed part

**Figure 10 — Indication of direction of mobility**

**6.8 Indication of interrelation of tolerance indication and conditions**

The flag symbol shall be indicated after the tolerance indicator.

It consists of a hexagon indicator including a figure to number different flags.

Different tolerance values for the same characteristic, but valid under different conditions, shall be given in several adjacent tolerance indications.

See [Figure 11](#).



a) Indications of the flag symbol

b) Indications of different values with different conditions

**Figure 11 — Examples of indications of the flag symbol**

## 6.9 Description of conditions

The description of conditions shall be indicated near the title box of the drawing.

The indication shall consist of the flag symbol as used in the corresponding tolerance indication and subsequent detailed information. For the list and sequence of conditions, see 6.10.

See Figure 12.

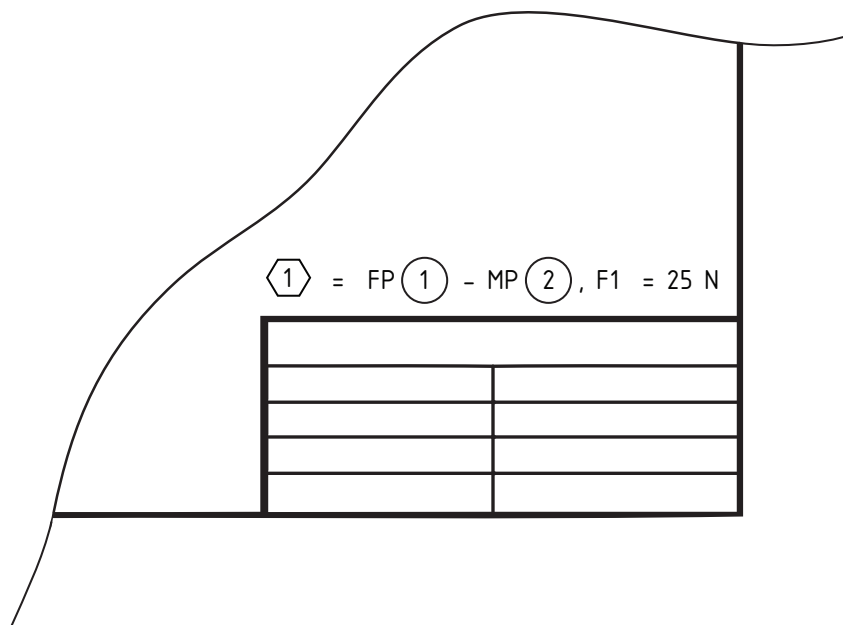

Figure 12 — Example of detailed description of conditions near the title box

## 6.10 List and sequence of conditions

### 6.10.1 List of conditions

#### 6.10.1.1 Mobility

Symbol “FP” shall be used for the fixed part.

Symbol “MP” shall be used for the movable part.

“FP” and “MP” shall be supplemented with the item reference of the concerned parts.

EXAMPLE FP  $\textcircled{1}$

#### 6.10.1.2 Direction of mobility

Symbol “T+” shall be used for translational mobility in positive direction.

Symbol “T-” shall be used for translational mobility in negative direction.

Symbol “R+” shall be used for rotational mobility in positive direction.

Symbol “R-” shall be used for rotational mobility in negative direction.

### 6.10.1.3 Velocity of mobility

Translational mobility (speed): Symbol  $v$ , value and unit (SI units, e.g.  $\text{mm}\cdot\text{s}^{-1}$ ) shall be indicated.

EXAMPLE 1  $v = 15 \text{ mm}\cdot\text{s}^{-1}$

Rotational mobility (angular speed or number of revolutions): Symbol  $\omega$ , value and unit  $\text{rad}\cdot\text{s}^{-1}$  or symbol RPM, value and unit  $\text{min}^{-1}$  shall be used.

EXAMPLE 2  $\omega = 3 \text{ rad}\cdot\text{s}^{-1}$

EXAMPLE 3 RPM = 500  $\text{min}^{-1}$

### 6.10.1.4 Force

Force shall be indicated with letter F, adjacent figure, value and unit N.

EXAMPLE 1  $F_1 = 25 \text{ N}$

If only the force of gravity is acting, only the gravity symbol shall be indicated.

EXAMPLE 2  $G_1$

### 6.10.1.5 Direction of gravity

If different directions of gravity (related to different orientations of the work piece) are indicated on the drawing, the related direction of gravity shall be indicated with letter G and the relevant number.

EXAMPLE  $G_1$

### 6.10.1.6 Further conditions

Further conditions like change of velocity or force over time or even full operational or test cycles shall be described in separate documentation which shall be referenced on the drawing.

## 6.10.2 Sequence of conditions

General structure: Conditions for fixed parts – Conditions for movable parts

The conditions as listed in [6.10.1](#) shall be written in following sequence:

— Mobility, Direction of mobility, Velocity of mobility, Force, Direction of gravity, Further conditions

EXAMPLE  $\textcircled{1} = \text{FP } \textcircled{1}, F_1 = 750 \text{ N} - \text{MP } \textcircled{2}, T+, v=25 \text{ mm}\cdot\text{s}^{-1}, F_2 = 425 \text{ N}, G_1$

## Annex A (normative)

### Relations and dimensions of graphical symbols

#### A.1 General requirement

In order to harmonize the size of the symbols specified in this International Standard with those of other inscriptions on technical drawings (dimensions, geometrical tolerances, etc.), the rules given in this annex, which are in accordance with ISO 81714-1, shall be observed. Further graphical symbols are given in ISO 3098-5.

#### A.2 Proportions

The graphical symbols, described in [Table 1](#) shall be drawn in accordance with [Figures A.1](#) to [A.8](#).

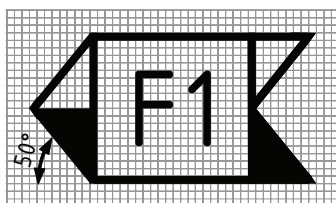

Figure A.1 — Force indicator

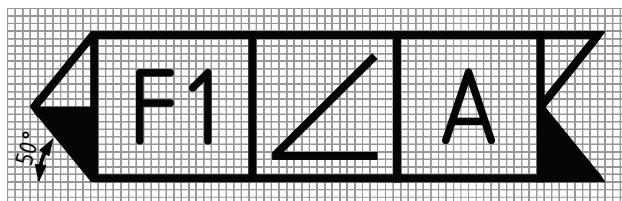

Figure A.2 — Force indicator including basic indication of specific direction of the force relative to a datum

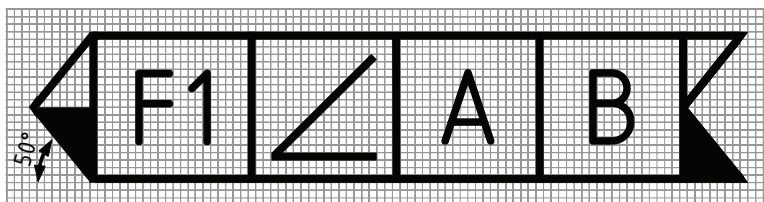

Figure A.3 — Force indicator including basic indication of specific direction of the force relative to a datum system

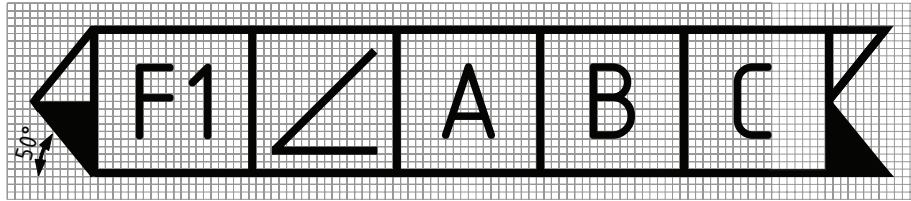

Figure A.4 — Force indicator including basic indication of specific direction of the force relative to a datum system

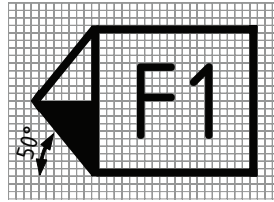

Figure A.5 — Complementary force indication

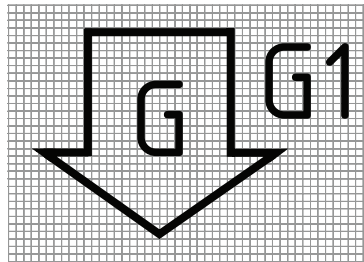

Figure A.6 — Gravity

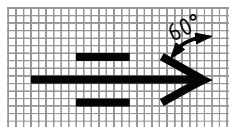
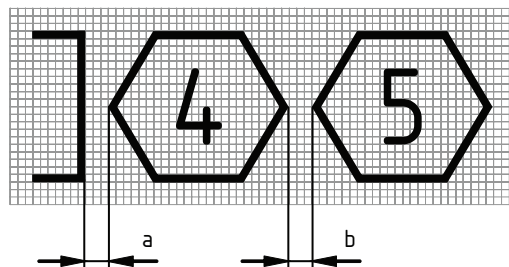

Figure A.7 — Mobility

Figure A.7 shows the symbol for “mobility – translational”. The symbol for “mobility – rotational” shall be drawn in a curved manner in relation to the contour of the work piece.



**Key**

- a Distance between symbol flag and tolerance indicator.
- b Distance in between different flag symbols.

Figure A.8 — Flag

## Annex B (informative)

### Example of run-out and size tolerances on a tapered roller bearing

See [Figure B.1](#).

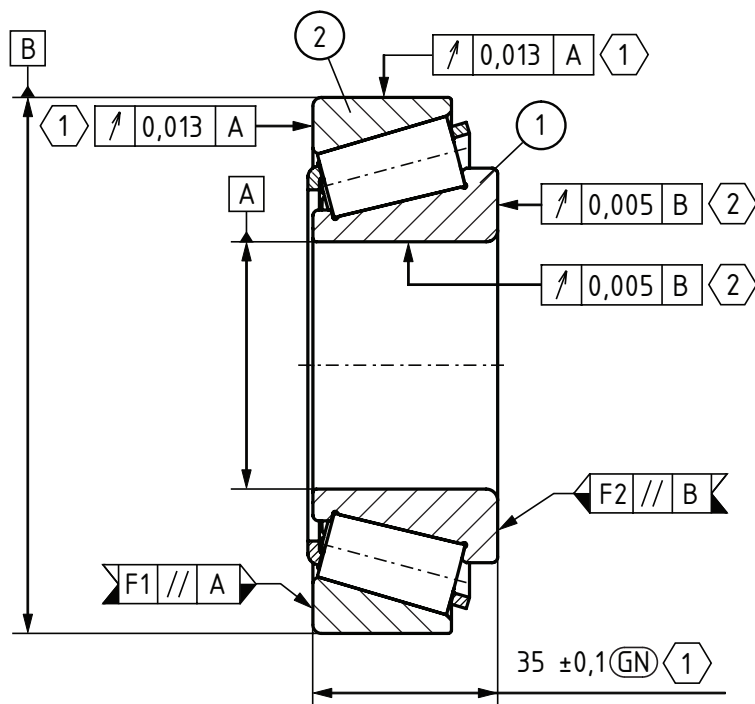

$$\textcircled{1} = \text{FP} \textcircled{1} - \text{MP} \textcircled{2}, F1 = 500 \text{ N}$$

$$\textcircled{2} = \text{FP} \textcircled{2} - \text{MP} \textcircled{1}, F2 = 500 \text{ N}$$

**Figure B.1 — Example of run-out and size tolerances on a tapered roller bearing**

## **Annex C** (informative)

### **Relation to the GPS matrix model**

#### **C.1 General**

For full details about the GPS matrix model, see ISO/TR 14638.

The ISO/GPS Masterplan given in ISO/TR 14638 gives an overview of the ISO/GPS system of which this document is a part. The fundamental rules of ISO/GPS given in ISO 8015 apply to this document and the default decision rules given in ISO 14253-1 apply to specifications made in accordance with this document, unless otherwise indicated.

#### **C.2 Information about this Technical Specification and its use**

This Technical Specification specifies the indication of conditions in between the parts of movable assemblies in conjunction with geometrical tolerancing according to ISO GPS standards. On geometrical tolerancing, one part of the assembly includes tolerance indications and another part includes corresponding datum indications.

#### **C.3 Position in the GPS matrix model**

This Technical Specification is a global GPS standard, which influences chain links 1 to 3 of the chain of standards on size, distance, angle, form of line dependent on datum, form of surface dependent on datum, orientation, location, circular run-out, total run-out and datums in the GPS matrix, as illustrated in [Table C.1](#).

**Table C.1 — Fundamental and general ISO GPS standards matrix**

	Global GPS standards						
<b>Fundamental GPS standards</b>	General GPS standards						
	<b>Chain link number</b>	<b>1</b>	<b>2</b>	<b>3</b>	<b>4</b>	<b>5</b>	<b>6</b>
	Size	•	•	•			
	Distance	•	•	•			
	Radius						
	Angle	•	•	•			
	Form of line independent of datum						
	Form of line dependent on datum	•	•	•			
	Orientation	•	•	•			
	Location	•	•	•			
	Circular run-out	•	•	•			
	Total run-out	•	•	•			
	Datums						
	Roughness profile						
	Waviness profile						
	Primary profile						
	Surface defects						
Edges							

#### **C.4 Related standards**

The related standards are those of the chains of standards indicated in [Table C.1](#).



## Bibliography

- [1] ISO/TR 14638, *Geometrical product specification (GPS) — Masterplan*
- [2] ISO 3098-2, *Technical product documentation — Lettering — Part 2: Latin alphabet, numerals and marks*
- [3] ISO 3098-5, *Technical product documentation — Lettering — Part 5: CAD lettering of the Latin alphabet, numerals and marks*
- [4] ISO 5459:2011, *Geometrical product specifications (GPS) — Geometrical tolerancing — Datums and datum systems*
- [5] ISO 8015:2011, *Geometrical product specifications (GPS) — Fundamentals — Concepts, principles and rules*
- [6] ISO 14253-1:1998, *Geometrical Product Specifications (GPS) — Inspection by measurement of workpieces and measuring equipment — Part 1: Decision rules for proving conformance or non-conformance with specifications*





# British Standards Institution (BSI)

BSI is the national body responsible for preparing British Standards and other standards-related publications, information and services.

BSI is incorporated by Royal Charter. British Standards and other standardization products are published by BSI Standards Limited.

## About us

We bring together business, industry, government, consumers, innovators and others to shape their combined experience and expertise into standards-based solutions.

The knowledge embodied in our standards has been carefully assembled in a dependable format and refined through our open consultation process. Organizations of all sizes and across all sectors choose standards to help them achieve their goals.

## Information on standards

We can provide you with the knowledge that your organization needs to succeed. Find out more about British Standards by visiting our website at [bsigroup.com/standards](http://bsigroup.com/standards) or contacting our Customer Services team or Knowledge Centre.

## Buying standards

You can buy and download PDF versions of BSI publications, including British and adopted European and international standards, through our website at [bsigroup.com/shop](http://bsigroup.com/shop), where hard copies can also be purchased.

If you need international and foreign standards from other Standards Development Organizations, hard copies can be ordered from our Customer Services team.

## Subscriptions

Our range of subscription services are designed to make using standards easier for you. For further information on our subscription products go to [bsigroup.com/subscriptions](http://bsigroup.com/subscriptions).

With **British Standards Online (BSOL)** you'll have instant access to over 55,000 British and adopted European and international standards from your desktop. It's available 24/7 and is refreshed daily so you'll always be up to date.

You can keep in touch with standards developments and receive substantial discounts on the purchase price of standards, both in single copy and subscription format, by becoming a **BSI Subscribing Member**.

**PLUS** is an updating service exclusive to BSI Subscribing Members. You will automatically receive the latest hard copy of your standards when they're revised or replaced.

To find out more about becoming a BSI Subscribing Member and the benefits of membership, please visit [bsigroup.com/shop](http://bsigroup.com/shop).

With a **Multi-User Network Licence (MUNL)** you are able to host standards publications on your intranet. Licences can cover as few or as many users as you wish. With updates supplied as soon as they're available, you can be sure your documentation is current. For further information, email [bsmusales@bsigroup.com](mailto:bsmusales@bsigroup.com).

## BSI Group Headquarters

389 Chiswick High Road London W4 4AL UK

## Revisions

Our British Standards and other publications are updated by amendment or revision.

We continually improve the quality of our products and services to benefit your business. If you find an inaccuracy or ambiguity within a British Standard or other BSI publication please inform the Knowledge Centre.

## Copyright

All the data, software and documentation set out in all British Standards and other BSI publications are the property of and copyrighted by BSI, or some person or entity that owns copyright in the information used (such as the international standardization bodies) and has formally licensed such information to BSI for commercial publication and use. Except as permitted under the Copyright, Designs and Patents Act 1988 no extract may be reproduced, stored in a retrieval system or transmitted in any form or by any means – electronic, photocopying, recording or otherwise – without prior written permission from BSI. Details and advice can be obtained from the Copyright & Licensing Department.

## Useful Contacts:

### Customer Services

**Tel:** +44 845 086 9001

**Email (orders):** [orders@bsigroup.com](mailto:orders@bsigroup.com)

**Email (enquiries):** [cservices@bsigroup.com](mailto:cservices@bsigroup.com)

### Subscriptions

**Tel:** +44 845 086 9001

**Email:** [subscriptions@bsigroup.com](mailto:subscriptions@bsigroup.com)

### Knowledge Centre

**Tel:** +44 20 8996 7004

**Email:** [knowledgecentre@bsigroup.com](mailto:knowledgecentre@bsigroup.com)

### Copyright & Licensing

**Tel:** +44 20 8996 7070

**Email:** [copyright@bsigroup.com](mailto:copyright@bsigroup.com)



...making excellence a habit.™