

PD ISO/TS 16955:2016



BSI Standards Publication

Prosthetics — Quantification of physical parameters of ankle foot devices and foot units

National foreword

This Published Document is the UK implementation of ISO/TS 16955:2016.

The UK participation in its preparation was entrusted to Technical Committee CH/168, Prosthetics and orthotics.

A list of organizations represented on this committee can be obtained on request to its secretary.

This publication does not purport to include all the necessary provisions of a contract. Users are responsible for its correct application.

© The British Standards Institution 2016.

Published by BSI Standards Limited 2016

ISBN 978 0 580 92002 8

ICS 11.040.40

Compliance with a British Standard cannot confer immunity from legal obligations.

This Published Document was published under the authority of the Standards Policy and Strategy Committee on 30 June 2016.

Amendments/corrigenda issued since publication

Date	Text affected
-------------	----------------------

**TECHNICAL
SPECIFICATION**

**ISO/TS
16955**

First edition
2016-06-15

**Prosthetics — Quantification of
physical parameters of ankle foot
devices and foot units**

*Prothèses — Quantification des paramètres physiques des dispositifs
de cheville/pied et unités pour les pieds*



Reference number
ISO/TS 16955:2016(E)

© ISO 2016



COPYRIGHT PROTECTED DOCUMENT

© ISO 2016, Published in Switzerland

All rights reserved. Unless otherwise specified, no part of this publication may be reproduced or utilized otherwise in any form or by any means, electronic or mechanical, including photocopying, or posting on the internet or an intranet, without prior written permission. Permission can be requested from either ISO at the address below or ISO's member body in the country of the requester.

ISO copyright office
Ch. de Blandonnet 8 • CP 401
CH-1214 Vernier, Geneva, Switzerland
Tel. +41 22 749 01 11
Fax +41 22 749 09 47
copyright@iso.org
www.iso.org

Contents

Page

Foreword	iv
Introduction	v
1 Scope	1
2 Normative references	1
3 Terms and definitions	1
4 Symbols and abbreviated terms	2
5 Requirements	2
6 Setup conditions	2
7 Quantification	3
7.1 Heel, mid-foot and toe characteristics.....	3
7.1.1 Procedure.....	3
7.1.2 Data collection and calculations.....	4
7.2 Roll-over characteristics.....	5
7.2.1 Procedure.....	5
7.2.2 Data collection and calculations.....	6
7.3 Torsional characteristic.....	7
7.3.1 Procedure.....	7
7.3.2 Data collection and calculations.....	8
7.4 Frontal plane characteristics.....	8
7.4.1 Procedure.....	8
7.4.2 Data collection and calculations.....	9
8 Accessories	10
8.1 General.....	10
8.2 Procedure.....	10
8.3 Results.....	10
Annex A (informative) Quick reference	11
Annex B (informative) Three dimensional locus of force contact point on foot-sole	12
Bibliography	17

Foreword

ISO (the International Organization for Standardization) is a worldwide federation of national standards bodies (ISO member bodies). The work of preparing International Standards is normally carried out through ISO technical committees. Each member body interested in a subject for which a technical committee has been established has the right to be represented on that committee. International organizations, governmental and non-governmental, in liaison with ISO, also take part in the work. ISO collaborates closely with the International Electrotechnical Commission (IEC) on all matters of electrotechnical standardization.

The procedures used to develop this document and those intended for its further maintenance are described in the ISO/IEC Directives, Part 1. In particular the different approval criteria needed for the different types of ISO documents should be noted. This document was drafted in accordance with the editorial rules of the ISO/IEC Directives, Part 2 (see www.iso.org/directives).

Attention is drawn to the possibility that some of the elements of this document may be the subject of patent rights. ISO shall not be held responsible for identifying any or all such patent rights. Details of any patent rights identified during the development of the document will be in the Introduction and/or on the ISO list of patent declarations received (see www.iso.org/patents).

Any trade name used in this document is information given for the convenience of users and does not constitute an endorsement.

For an explanation on the meaning of ISO specific terms and expressions related to conformity assessment, as well as information about ISO's adherence to the World Trade Organization (WTO) principles in the Technical Barriers to Trade (TBT) see the following URL: www.iso.org/iso/foreword.html.

The committee responsible for this document is ISO/TC 168 *Prosthetics and orthotics*.

Introduction

Three major factors contribute to foot design:

- a) shape and size;
- b) strength requirements;
- c) functional performance.

Where

- a) is obvious and defined by the footwear,
- b) is specified in ISO 22523 referring to ISO 22675 (but is not suitable for use as a guide for the selection of a specific ankle-foot device or foot unit in the prescription of an individual lower limb prosthesis), and
- c) is addressed in this Technical Specification.

The AOPA group of ISO/TC 168 members between 2006 and 2009 carried out work on a method to replace design criteria for prosthetic ankle-foot devices with compliance criteria which would be applicable to both jointed devices and unjointed devices with elastic elements. In 2010, the working group “Testing” convened in Seattle, Washington and decided to work on a standard, based on the work of the AOPA group and other international groups. The vision statement was: “To develop a standard which describes quantitative methods to evaluate or assess key performance indicators of prosthetic ankle-foot devices which are correlated to measurable prosthesis user benefit.”

The subsequent work on this task has made it clear that it consists of (at least) two elements: firstly, to develop a standard which describes quantitative methods to evaluate or assess key performance indicators and secondly, to investigate and attempt to establish the correlation between these measures and relevant measures of prosthetic user benefit. This Technical Specification describes solely the quantitative methods to evaluate or assess key performance indicators.

The following definitions apply in understanding how to implement an ISO International Standard and other normative ISO deliverables (TS, PAS, IWA).

- “shall” indicates a requirement
- “should” indicates a recommendation
- “may” is used to indicate that something is permitted
- “can” is used to indicate that something is possible, for example, that an organization or individual is able to do something

In 3.3.1 of the ISO/IEC Directives, Part 2 (sixth edition, 2011) defines a requirement as an “expression in the content of a document conveying criteria to be fulfilled if compliance with the document is to be claimed and from which no deviation is permitted.”

In 3.3.2 of the ISO/IEC Directives, Part 2 (sixth edition, 2011) defines a recommendation as an “expression in the content of a document conveying that among several possibilities one is recommended as particularly suitable, without mentioning or excluding others, or that a certain course of action is preferred but not necessarily required, or that (in the negative form) a certain possibility or course of action is deprecated but not prohibited.”

Prosthetics — Quantification of physical parameters of ankle foot devices and foot units

1 Scope

This Technical Specification describes quantitative methods to evaluate or assess key performance indicators of prosthetic ankle foot devices.

For each method, the set-up and test configurations are described. Also included is a variety of parameters which are derived or calculated from the recorded data.

2 Normative references

The following documents, in whole or in part, are normatively referenced in this document and are indispensable for its application. For dated references, only the edition cited applies. For undated references, the latest edition of the referenced document (including any amendments) applies.

ISO 10328, *Prosthetics — Structural testing of lower-limb prostheses — Requirements and test methods*

ISO 22523:2006, *External limb prostheses and external orthoses — Requirements and test methods*

ISO 22675:2016, *Prosthetics — Testing of ankle-foot devices and foot units — Requirements and test methods*

3 Terms and definitions

For the purposes of this document, the following terms and definitions apply.

3.1

heel, mid-foot and toe characteristics

physical parameters to describe the response of the ankle foot device under load after heel strike in mid stance and prior toe off

3.2

roll-over characteristics

physical parameters to describe the sagittal plane properties of the ankle foot device relevant for the patient during stance-phase

3.3

full contact motion

physical parameter to describe the angular range of motion of the shin where the heel and the toe are in contact with the ground simultaneously

3.4

torsional characteristic

physical parameter to describe the rotational response of the ankle foot device under load and additional torque in transversal plane

3.5

frontal plane characteristics

physical parameter to describe the frontal plane response of the ankle foot device during roll over on four different tilted ground angles in frontal plane

4 Symbols and abbreviated terms

Symbols and abbreviated terms are those used in ISO 10328 and ISO 22675.

5 Requirements

To determine comprehensive ankle foot device performance and to claim compliance with this Technical Specification, all parameters shall be quantified and the strength requirements specified in ISO 22523:2006, 4.4, shall be met.

If an ankle foot device allows for different adjustments on key performance indicators, the manufacturer/submitter shall define the settings relevant for quantification. To claim compliance with this Technical Specification, all parameters shall be quantified in the specific adjustments and the strength requirements specified in ISO 22523:2006, 4.4, shall be met.

Samples for the quantification shall be from the same production batch as those for strength testing.

If not otherwise specified in this Technical Specification, the test preparation as described in ISO 10328 or ISO 22675 shall apply.

NOTE The order of tests given in [Table A.1](#) minimizes the effort for test setup and configuration.

6 Setup conditions

Use the coordinate system and test configurations specified in ISO 22675:2016, Clause 6, except P_T is located at 700 mm height on a line which is located at midfoot and parallel to the u-axis.

The test methods specified are defined for a prosthetic foot of size 26 cm and appropriate for a 70 kg amputee.

For all the described test methods, a force moment sensor shall be positioned above midfoot and at the height of 500 mm, see [Figure 1](#).

In order to quantify the influence of compliant components between knee and ankle foot device, the force moment sensor is positioned at a height of 500 mm.

A displacement sensor rigidly connected to the force moment sensor parallel to u-axis shall be used to record vertical displacement (s_u).

An angular sensor rigidly connected to the force moment sensor perpendicular to u-axis shall be used to record the torsional angle (α_u).

Using the data acquired by the sensors, the following characteristics shall be calculated.

— Stiffness at static plate angle $D_1 = (\Delta F_u / \Delta s_u)$

— Lever arm length at static plate angle $l = (M_o / F_u)$

NOTE Calculations in ranges of $F_u < 10 \% F_{u\max}$ to be considered carefully because of noise.

— Lever arm length changes at static plate angle $\Delta l_s = l_2 - l_1$

— Effective foot length at tilting plate $\Delta l_t = l_2 - l_1$

— Full contact motion at tilting plate $\Delta \alpha = \alpha_2 - \alpha_1$

- Energy at static plate angle
- Torsional stiffness
- Torsional angular range
- Effective foot width at tilting plate

$$E = \int F_u \cdot \Delta s_u$$

$$D_\alpha = (\Delta M_u / \Delta \alpha_u)$$

$$\Delta \alpha_u = \alpha_{u2} - \alpha_{u1}$$

$$\Delta l_{wt} = l_2 - l_1$$

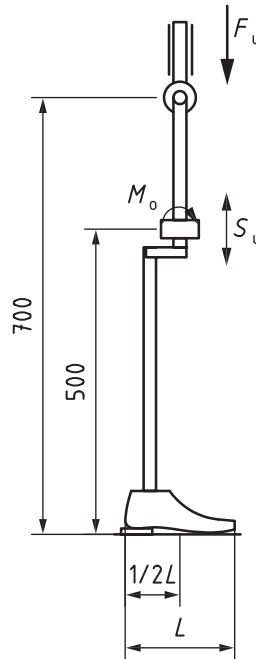

Figure 1 — Setup

7 Quantification

7.1 Heel, mid-foot and toe characteristics

7.1.1 Procedure

Perform the quantification of the heel, mid-foot and toe characteristics using the geometrical configuration of foot and foot platform described for loading in ISO 22675:2016, 13.4.1.3, using plate angles of $-7,5^\circ$ and 10° in addition (see [Figure 2](#)).

The peak force in the loading profile for quantification of the heel and toe characteristics (see [Figure 3](#)) shall be in accordance with 120 % (824 N) of the maximum body weight for which the ankle foot device is designed. The loading and unloading time shall be within $(1 \pm 0,1)$ s.

Perform the quantification of mid-foot characteristic as stated above but with the foot plate horizontal (0°) and the peak force in the loading profile (see [Figure 3](#)) in accordance with 200 % (1 373 N) of the maximum body weight for which the ankle foot device is designed. The loading and unloading time shall be within $(1 \pm 0,1)$ s.

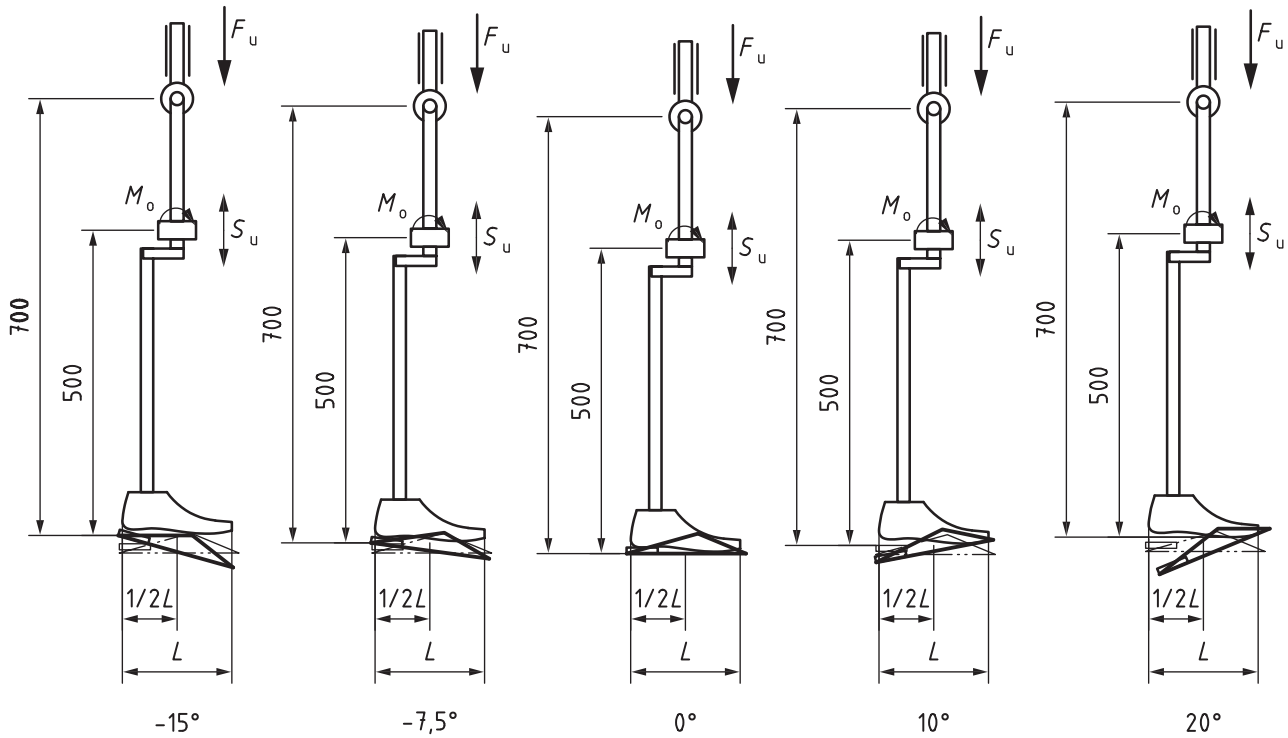
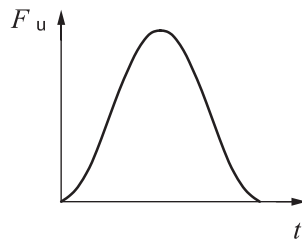

Figure 2 — Heel, mid-foot and toe characteristics (tilting angle of foot platform)



The loading profile shall be a sinusoidal wave with the peak at the specified load.

Figure 3 — Loading profile

7.1.2 Data collection and calculations

During the test, vertical displacement (s_u), vertical force (F_u) and outward moment (M_o) shall be recorded.

Using this data the following characteristics shall be calculated (see also [Table 1](#)).

Table 1 — Heel, mid-foot and toe characteristics

Test	Parameter	Measured signal/Calculated value
Heel and toe	1) Stiffness	
	2) Lever arm length at $F_{u\max}$	
	3) Lever arm length changes	
	4) Moment	
	5) Energy	
Mid-foot	1) Stiffness	
	2) Lever arm length at $F_{u\max}$	
	3) Energy	

7.2 Roll-over characteristics

7.2.1 Procedure

Perform the quantification of the roll-over characteristics (see [Figure 4](#)) using the geometrical configuration of foot and foot platform and the loading profile described in ISO 22675:2016, 13.4.2, except

- applying the force of $F_{1c\max}$ between the plate angles -15° and $+20^\circ$ (see [Figure 5](#)), and
- the duration of the loading profile shall be within $600\text{ ms} \pm 10\%$.

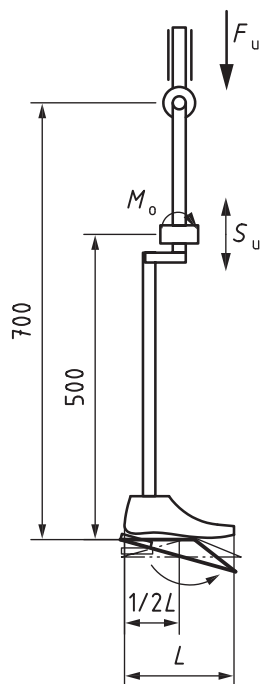

Figure 4 — Roll-over characteristics

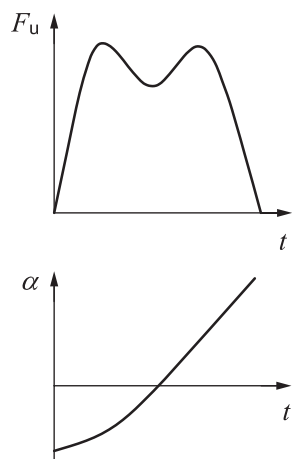
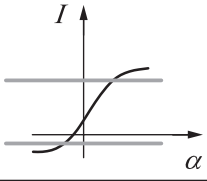
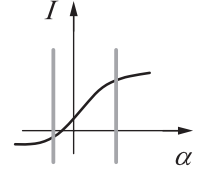

Figure 5 — Loading profile and foot platform angle

7.2.2 Data collection and calculations

During the test, foot platform angle (α), vertical force (F_u) and outward moment (M_o) shall be recorded. Using this data the following characteristics shall be calculated as shown in [Table 2](#).

Table 2 — Roll-over characteristics

Test	Parameter	Measured signal/Calculated value
Rollover	1) Effective foot length	
	2) Full contact motion	

7.3 Torsional characteristic

7.3.1 Procedure

Perform the quantification of torsional characteristics using the geometrical configuration described in 7.1.1 (mid-foot characteristics) except that the vertical force (F_u) is applied at a constant level in accordance with 100 % of the maximum body weight (687 N) for which the ankle foot device is designed (Figure 6).

Apply the force profile as shown in Figure 7.

Apply a torsional moment of -15 Nm to $+15$ Nm while the foot is under maximum load (Figure 7).

The torsional moment time shall be within (10 ± 1) s.

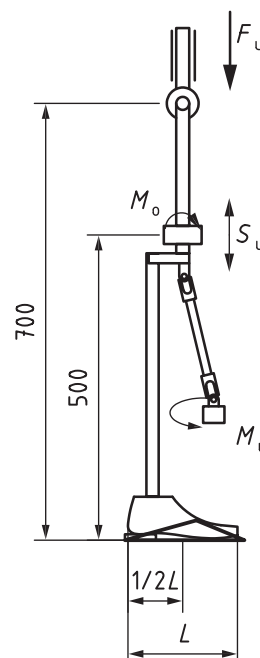

Figure 6 — Torsional characteristics

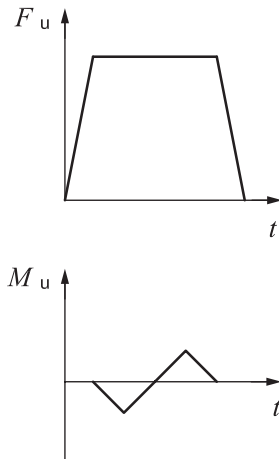

Figure 7 — Force and moment profile

7.3.2 Data collection and calculations

During the test, torsional angle (α_u) and torsional moment (M_u) shall be recorded.

Using this data the following characteristics shall be calculated as shown in [Table 3](#).

Table 3 — Torsional characteristic

Test	Parameter	Measured Signal/Calculated Value
Torsion	1) Torsional stiffness 2) Torsional angular range	

7.4 Frontal plane characteristics

7.4.1 Procedure

Perform the quantification of the frontal plane characteristics (see [Figure 8](#)) using the setup and profiles described in [7.2.1](#), except

- the tilting plate is tilted statically in the frontal plane in addition to the tilting movement in sagittal-plane,
- the heel dummy is mounted in the frontal plane angle on top of the tilted plate,
- the frontal angle is set in an angle of $\pm 5^\circ$ and in an angle of $\pm 10^\circ$ to quantify the medial and lateral characteristics,
- the joint in the top load application point is blocked against rotation about the u-axis.

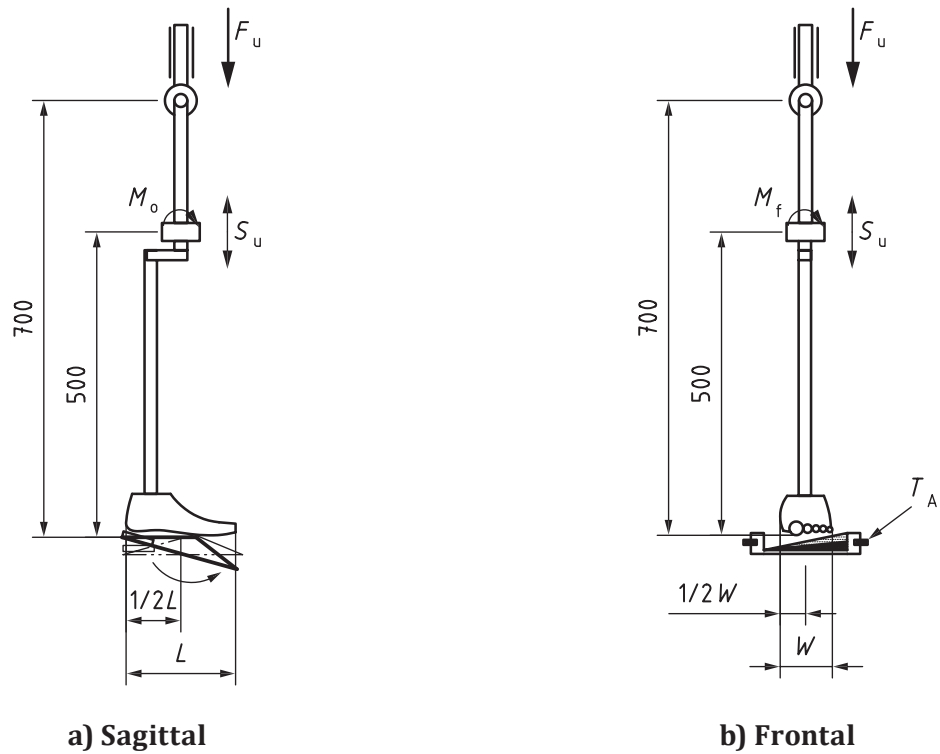

Figure 8 — Frontal plane characteristics

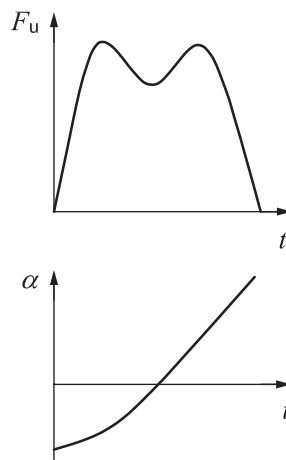
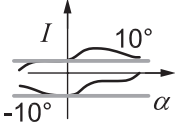

Figure 9 — Loading profile and foot platform angular range in sagittal plane

7.4.2 Data collection and calculations

During the test, foot platform angle (α), vertical force (F_u) and forward moment (M_f) shall be recorded. Using this data the following characteristics shall be calculated as shown in [Table 4](#).

Table 4 — Frontal plane characteristics

Test	Parameter	Measured Signal / Calculated Value
Frontal Plane	Effective foot width	

8 Accessories

8.1 General

Torsion adapters, shock absorbers, ankle units and other functional components can be tested by doing a comparison test.

8.2 Procedure

Run the tests specified in [Clause 7](#) using a relevant foot and the functional component.

Repeat the tests without the functional component.







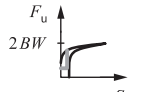
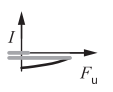
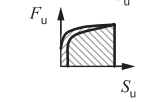

8.3 Results

Compare the results in order to quantify the functional influence of the component to the relevant foot.

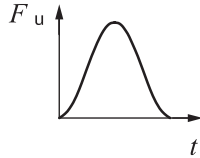
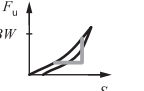
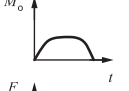
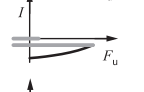
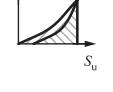
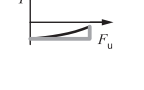
Annex A (informative)

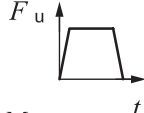
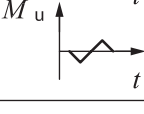
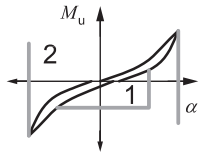
Quick reference

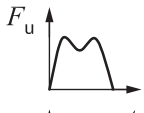
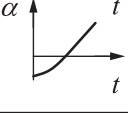
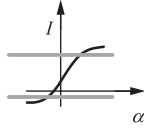
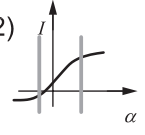
Table A.1 — Quick reference

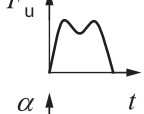
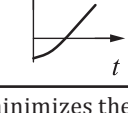
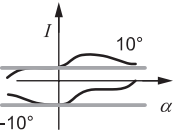
Test ^a		Test profiles	Parameters	Measured signal/Calculated value
7.1			1) Stiffness 2) Lever arm length 3) Energy	1)  2)  3) 
			1) Stiffness 2) Lever arm length 3) Lever arm length changes 4) Moment 5) Energy	1)  4)  2)  5)  3) 
				
7.3		 	1) Torsional stiffness 2) Torsional angular range	
7.2		 	1) Effective foot length 2) Full contact motion	1)  2) 
7.4		 	1) Effective foot width	

^a The order of tests given in this table minimizes the effort for test setup and configuration.

Annex B (informative)

Three dimensional locus of force contact point on foot-sole

The force contact point, fcp, (f_1, u_1, o_1) is calculated as the cross point of line A (screw line calculated from the output of 6-axis load cell) and line B (swing foot plate surface) shown in [Figure B.1 a](#)). The origin is on the centre of 6-axis load cell. Locus of the point (f_1, u_1, o_1) is corresponding to but not equal to the “roll-over shape” used by References [1] and [2]. The “roll-over shape” is the locus of cop (centre of pressure) on the foot-sole in sagittal plane.

The force \vec{F} and the moment \vec{M} measured by a 6-axis load cell are positioned on the centre of the load cell, and are equally transformed to the force \vec{F} and the moment \vec{M}_p on the screw line shown in [Figure B.2](#). The 6-axis load cell should be closely positioned to the foot for higher resolution.

$$\vec{M} = \vec{M}_p + \vec{M}_r \quad (\text{B.1})$$

$$\vec{M}_p = a \cdot \vec{F} \quad (\vec{M}_p // \vec{F}) \quad (\text{B.2})$$

$$\vec{M}_r = \vec{r}_a \times \vec{F} \quad (\vec{M}_r \perp \vec{F}) \quad (\text{B.3})$$

$$(\vec{r} - \vec{r}_a) // \vec{F} \text{ then}$$

$$(\vec{r} - \vec{r}_a) \times \vec{F} = \vec{0} \quad (\text{B.4})$$

From [Formula \(B.2\)](#) and [Formula \(B.3\)](#), [Formula \(B.4\)](#) is transformed to [Formula \(B.5\)](#):

$$\vec{r} \times \vec{F} - \vec{M} + (a \cdot \vec{F}) = \vec{0} \quad (\text{B.5})$$

[Formula \(B.5\)](#) is the screw line A, where $\vec{r} = (f, u, o)^t$, $\vec{F} = (F_f, F_u, F_o)^t$, $\vec{M} = (M_f, M_u, M_o)^t$

From the relation of [Formula \(B.6\)](#), a is calculated from [Formula \(B7\)](#):

$$\vec{M} \cdot \vec{F} = (\vec{M}_p + \vec{M}_r) \cdot \vec{F} = \vec{M}_p \cdot \vec{F} = a \cdot \vec{F} \cdot \vec{F} \quad (\text{B.6})$$

$$a = \frac{\vec{M} \cdot \vec{F}}{\vec{F} \cdot \vec{F}} = \frac{M_f F_f + M_u F_u + M_o F_o}{F_f^2 + F_u^2 + F_o^2} \quad (\text{B.7})$$

From [Formula \(B.5\)](#) and [Formula \(B.6\)](#), the screw line A on each plane is expressed as follows.

$$\text{— Sagittal plane (} f\text{-}u \text{ plane) } fF_u - uF_f - M_o + aF_o = 0 \quad (\text{B.8})$$

$$\text{— Frontal plane (} u\text{-}o \text{ plane) } uF_o - oF_u - M_f + aF_f = 0 \quad (\text{B.9})$$

When the 6-axis load cell is positioned as shown in [Figure B.1 b](#)), the screw line A on the sagittal plane is expressed as [Formula \(B.8\)](#) in which f is changed to $f - f_a$. This should be applied to [Formula \(B.10\)](#).

In [Formulae \(B.11\)](#), [\(B.12\)](#) and [\(B.13\)](#), $f(t)$ should be changed to $f(t) \cdot f_a$. In [Formula \(B.13\)](#), $f_1(t)$ should be changed to $f_1(t) \cdot f_a$.

The equation of line B (swing foot plate) is expressed as [Formula \(B.10\)](#) from [Figure B.3](#) and [Figure B.4](#).

$$u = \tan\theta \cdot f - u_1 - \left(\frac{u_{TA,L}}{\cos\theta} + f_{TA,L} \tan\theta \right) \quad (B.10)$$

Then, line A and line B in sagittal plane are expressed as the function of time (t).

Line A:

$$f(t)F_u(t) - u(t)F_f(t) - M_o(t) + aF_o(t) = 0 \quad (B.11)$$

Line B:

$$u(t) = \tan\theta(t) \cdot f(t) - u_1(t) - \left(\frac{u_{TA,L}}{\cos\theta(t)} + f_{TA,L} \tan\theta(t) \right) \quad (B.12)$$

From [Formulae \(B.11\)](#) and [\(B.12\)](#),

$$f(t)F_u(t) - \tan\theta(t)f(t)F_f(t) + u_1(t)F_f(t) + \left(\frac{u_{TA,L}}{\cos\theta(t)} + f_{TA,L} \tan\theta(t) \right) F_f(t) - M_o(t) + aF_o(t) = 0 \quad (B.13)$$

then,

$$f_1(t) = \frac{-u_1(t)F_f(t) - \left(\frac{u_{TA,L}}{\cos\theta(t)} + f_{TA,L} \tan\theta(t) \right) F_f(t) + M_o(t) - aF_o(t)}{F_u(t) - \tan\theta(t)F_f(t)} \quad (B.14)$$

By substituting $f_1(t)$ for $f(t)$ in [Formula \(B.12\)](#), $u_1(t)$ is determined, and the locus of the point (f_1, u_1) , the locus of the force contact point on the foot-sole in the sagittal plane is fixed.

Screw line A in the frontal plane (u - o plane) is expressed as [Formula \(B.15\)](#) from [Formula \(B.8\)](#).

$$u(t)F_o(t) - o(t)F_u(t) - M_f(t) + aF_f(t) = 0 \quad (B.15)$$

By substituting $u_1(t)$ for $u(t)$ in [Formula \(B.15\)](#), $o_1(t)$ is determined, and the locus of the point (f_1, u_1, o_1) , the three dimensional locus of force contact point on foot-sole is fixed.

One of the calculated results of three dimensional locus of force contact point on foot-sole is shown in [Figure B.5](#).

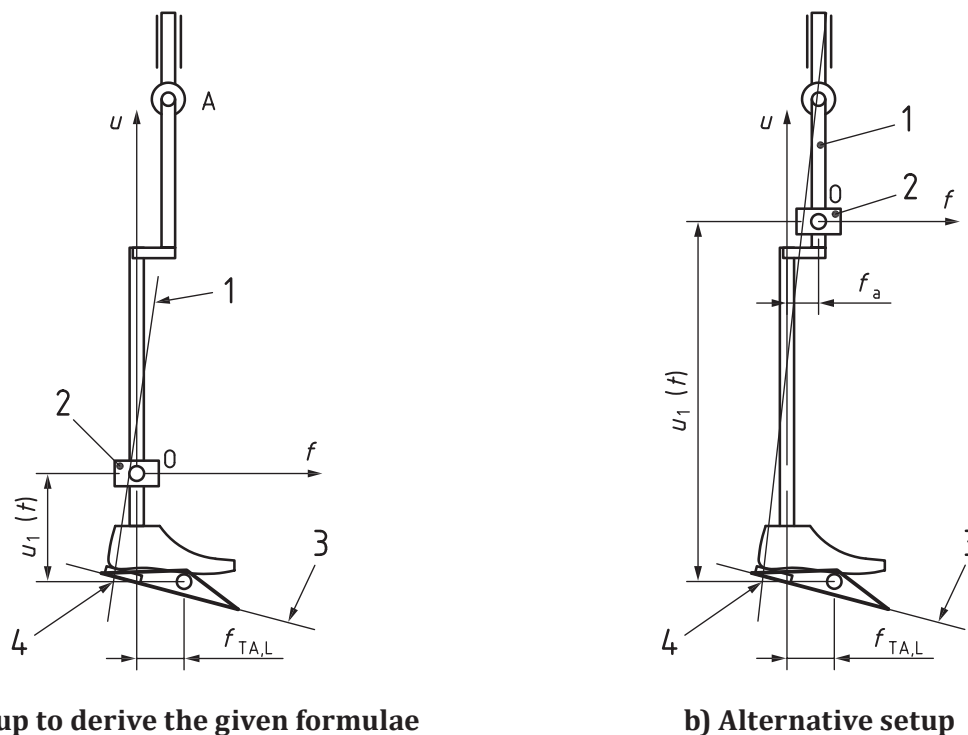

Key

- 1 screw line (Line A)
- 2 load cell (M, F)
- 3 foot plate (Line B)
- 4 force contact point fcp (f_1, u_1, o_1)

Figure B.1 — Principle to measure the 3D locus of the force contact point on foot-sole

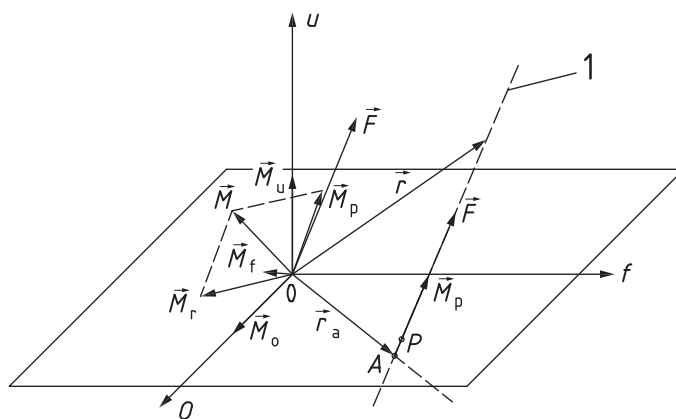

Key

- 1 screw line (Line A)

Figure B.2 — Relation between output of 6-axis load cell and screw line

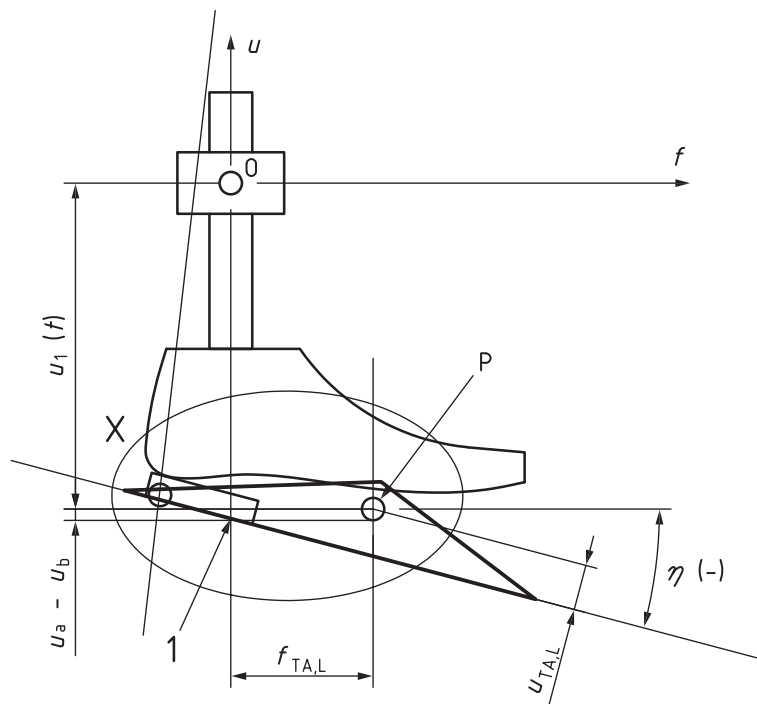

Key

- 1 u-axis interception point of line B
- X details see [Figure B.4](#)

Figure B.3 — Dimension of line B (foot plate)

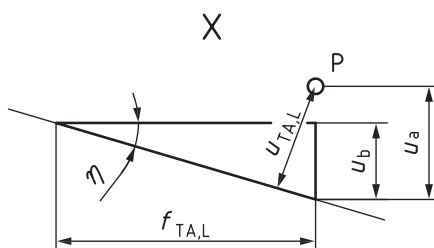

Key

$$u_b = -f_{TA,L} \tan \theta$$

$$u_a = u_{TA,L} / \cos \theta$$

$$u_a - u_b = \frac{u_{TA,L}}{\cos \theta} + f_{TA,L} \tan \theta$$

Figure B.4 — u-axis interception point of line B

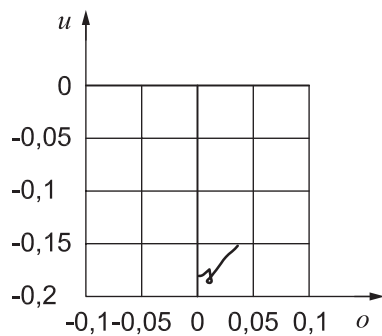

a) Frontal plane

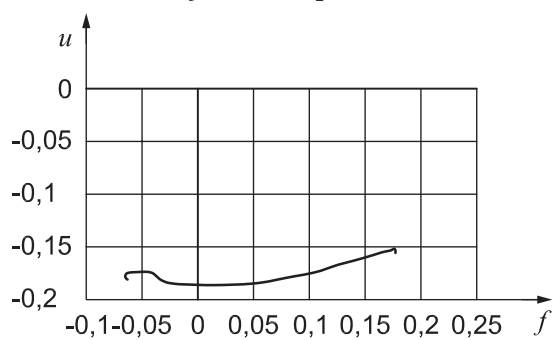

b) Sagittal plane

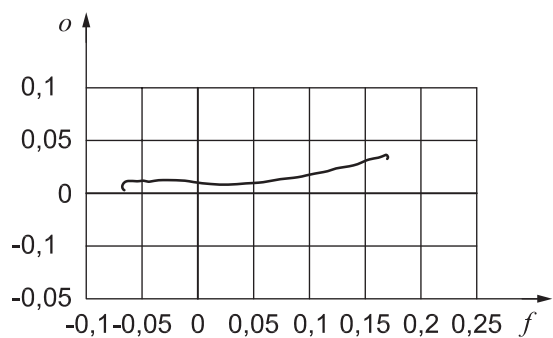

c) Transverse plane

Figure B.5 — Example of the three dimensional locus of the foot contact point on the foot-sole
(Foot: 1D10; Load level: P3; Frequency: 0,5Hz)

Bibliography

- [1] HANSEN A. Prosthetic foot roll-over shapes with implications for alignment of trans-tibial prostheses. *Prosthet. Orthot. Int.* 2000, **24** pp. 205–215
- [2] CURTZE C. Comparative roll-over analysis of prosthetic feet. *J. Biomech.* 2009, **42** pp. 1746–1753

British Standards Institution (BSI)

BSI is the national body responsible for preparing British Standards and other standards-related publications, information and services.

BSI is incorporated by Royal Charter. British Standards and other standardization products are published by BSI Standards Limited.

About us

We bring together business, industry, government, consumers, innovators and others to shape their combined experience and expertise into standards-based solutions.

The knowledge embodied in our standards has been carefully assembled in a dependable format and refined through our open consultation process. Organizations of all sizes and across all sectors choose standards to help them achieve their goals.

Information on standards

We can provide you with the knowledge that your organization needs to succeed. Find out more about British Standards by visiting our website at bsigroup.com/standards or contacting our Customer Services team or Knowledge Centre.

Buying standards

You can buy and download PDF versions of BSI publications, including British and adopted European and international standards, through our website at bsigroup.com/shop, where hard copies can also be purchased.

If you need international and foreign standards from other Standards Development Organizations, hard copies can be ordered from our Customer Services team.

Copyright in BSI publications

All the content in BSI publications, including British Standards, is the property of and copyrighted by BSI or some person or entity that owns copyright in the information used (such as the international standardization bodies) and has formally licensed such information to BSI for commercial publication and use.

Save for the provisions below, you may not transfer, share or disseminate any portion of the standard to any other person. You may not adapt, distribute, commercially exploit, or publicly display the standard or any portion thereof in any manner whatsoever without BSI's prior written consent.

Storing and using standards

Standards purchased in soft copy format:

- A British Standard purchased in soft copy format is licensed to a sole named user for personal or internal company use only.
- The standard may be stored on more than 1 device provided that it is accessible by the sole named user only and that only 1 copy is accessed at any one time.
- A single paper copy may be printed for personal or internal company use only.

Standards purchased in hard copy format:

- A British Standard purchased in hard copy format is for personal or internal company use only.
- It may not be further reproduced – in any format – to create an additional copy. This includes scanning of the document.

If you need more than 1 copy of the document, or if you wish to share the document on an internal network, you can save money by choosing a subscription product (see 'Subscriptions').

Reproducing extracts

For permission to reproduce content from BSI publications contact the BSI Copyright & Licensing team.

Subscriptions

Our range of subscription services are designed to make using standards easier for you. For further information on our subscription products go to bsigroup.com/subscriptions.

With **British Standards Online (BSOL)** you'll have instant access to over 55,000 British and adopted European and international standards from your desktop. It's available 24/7 and is refreshed daily so you'll always be up to date.

You can keep in touch with standards developments and receive substantial discounts on the purchase price of standards, both in single copy and subscription format, by becoming a **BSI Subscribing Member**.

PLUS is an updating service exclusive to BSI Subscribing Members. You will automatically receive the latest hard copy of your standards when they're revised or replaced.

To find out more about becoming a BSI Subscribing Member and the benefits of membership, please visit bsigroup.com/shop.

With a **Multi-User Network Licence (MUNL)** you are able to host standards publications on your intranet. Licences can cover as few or as many users as you wish. With updates supplied as soon as they're available, you can be sure your documentation is current. For further information, email subscriptions@bsigroup.com.

Revisions

Our British Standards and other publications are updated by amendment or revision.

We continually improve the quality of our products and services to benefit your business. If you find an inaccuracy or ambiguity within a British Standard or other BSI publication please inform the Knowledge Centre.

Useful Contacts

Customer Services

Tel: +44 345 086 9001

Email (orders): orders@bsigroup.com

Email (enquiries): cservices@bsigroup.com

Subscriptions

Tel: +44 345 086 9001

Email: subscriptions@bsigroup.com

Knowledge Centre

Tel: +44 20 8996 7004

Email: knowledgecentre@bsigroup.com

Copyright & Licensing

Tel: +44 20 8996 7070

Email: copyright@bsigroup.com

BSI Group Headquarters

389 Chiswick High Road London W4 4AL UK