

PD ISO/TS 16785:2014



BSI Standards Publication

Electronic Fee Collection (EFC) — Interface definition between DSRC-OBE and external in- vehicle devices

bsi.

...making excellence a habit.™

National foreword

This Published Document is the UK implementation of ISO/TS 16785:2014.

The UK participation in its preparation was entrusted to Technical Committee EPL/278, Intelligent transport systems.

A list of organizations represented on this committee can be obtained on request to its secretary.

This publication does not purport to include all the necessary provisions of a contract. Users are responsible for its correct application.

© The British Standards Institution 2014. Published by BSI Standards Limited 2014

ISBN 978 0 580 85575 7

ICS 03.220.01; 35.240.60

Compliance with a British Standard cannot confer immunity from legal obligations.

This Published Document was published under the authority of the Standards Policy and Strategy Committee on 30 November 2014.

Amendments issued since publication

Date	Text affected
------	---------------

TECHNICAL SPECIFICATION

ISO/TS 16785

First edition
2014-11-01

Electronic Fee Collection (EFC) — Interface definition between DSRC- OBE and external in-vehicle devices

*Perception du télépéage — Définition de l'interface entre
l'équipement à bord à communications dédiées à courte portée
(DSRC-OBE) et les dispositifs externes embarqués*



Reference number
ISO/TS 16785:2014(E)

© ISO 2014



COPYRIGHT PROTECTED DOCUMENT

© ISO 2014

All rights reserved. Unless otherwise specified, no part of this publication may be reproduced or utilized otherwise in any form or by any means, electronic or mechanical, including photocopying, or posting on the internet or an intranet, without prior written permission. Permission can be requested from either ISO at the address below or ISO's member body in the country of the requester.

ISO copyright office
Case postale 56 • CH-1211 Geneva 20
Tel. + 41 22 749 01 11
Fax + 41 22 749 09 47
E-mail copyright@iso.org
Web www.iso.org

Published in Switzerland

Contents

Page

Foreword	iv
Introduction	v
1 Scope	1
2 Normative references	2
3 Terms and definitions	3
4 Symbols and abbreviated terms	4
5 Tolling models with external in-vehicle devices	5
5.1 General.....	5
5.2 Applicable tolling services.....	6
5.3 Basic DSRC tolling.....	6
5.4 Mobile-assisted DSRC tolling.....	7
5.5 Universal tolling.....	8
6 Message sets	10
6.1 General.....	10
6.2 Payment means status.....	12
6.3 Payment fee.....	12
6.4 Account update.....	13
6.5 Compliance checking data (CCCAttributes).....	13
6.6 Localization data (LacData).....	13
7 Security aspects	13
7.1 General.....	13
7.2 OBE interface profile.....	14
Annex A (normative) Data type specification	15
Annex B (normative) Protocol Implementation Conformance Statement proforma	17
Annex C (informative) Mobile-assisted DSRC tolling in Korea	19
Annex D (informative) Other possible tolling models	22
Annex E (informative) Applicable ITS services	25
Bibliography	30

Foreword

ISO (the International Organization for Standardization) is a worldwide federation of national standards bodies (ISO member bodies). The work of preparing International Standards is normally carried out through ISO technical committees. Each member body interested in a subject for which a technical committee has been established has the right to be represented on that committee. International organizations, governmental and non-governmental, in liaison with ISO, also take part in the work. ISO collaborates closely with the International Electrotechnical Commission (IEC) on all matters of electrotechnical standardization.

The procedures used to develop this document and those intended for its further maintenance are described in the ISO/IEC Directives, Part 1. In particular the different approval criteria needed for the different types of ISO documents should be noted. This document was drafted in accordance with the editorial rules of the ISO/IEC Directives, Part 2 (see www.iso.org/directives).

Attention is drawn to the possibility that some of the elements of this document may be the subject of patent rights. ISO shall not be held responsible for identifying any or all such patent rights. Details of any patent rights identified during the development of the document will be in the Introduction and/or on the ISO list of patent declarations received (see www.iso.org/patents).

Any trade name used in this document is information given for the convenience of users and does not constitute an endorsement.

For an explanation on the meaning of ISO specific terms and expressions related to conformity assessment, as well as information about ISO's adherence to the WTO principles in the Technical Barriers to Trade (TBT) see the following URL: [Foreword - Supplementary information](#)

The committee responsible for this document is ISO/TC 204, *Intelligent transport systems*.

Introduction

Background and motivation

With regards to reassessing the present fuel tax schemes to cope with prevailing plug-in hybrid vehicle and electric vehicle or introducing congestion charging system to urban roads or inter-urban roads etc., the needs for expanding toll roads are becoming worthy of notice in the world.

In countries where Dedicated Short-Range Communication (DSRC)-based Electronic Fee Collection (EFC) systems were introduced for toll roads and have been operated widely, making their EFC equipment applicable to present non-toll roads, such as urban roads or inter-urban roads, becomes a significant issue to be considered and solved.

There are three cases of introducing EFC to cope with those situations:

- Case-1: DSRC-based EFC should be introduced to new toll roads, as well as present toll roads.
- Case-2: Autonomous EFC should be introduced to new toll roads and present toll roads as replacing.
- Case-3: DSRC-based EFC should be operated for present toll roads as they are, and autonomous EFC should be introduced to new toll roads.

In case of both Case-1 and Case-2, necessary interface definitions and test procedures are already covered by existing EFC standards. However, in Case-3, as shown in [Figure 1](#), current On-Board Equipment (OBE) used for DSRC-based EFC should be considered to be used for autonomous EFC covering new toll roads in keeping consistency with present toll roads.

DSRC-OBE should be expanded functionally by cooperating with external in-vehicle devices composed of a Global Navigation Satellite Systems (GNSS) module and/or a cellular module and/or other related modules; therefore, DSRC-OBE is possible to be reused for new EFC environment consisting of DSRC-based EFC and autonomous systems.

Consequently, an application interface definition between DSRC-OBE and external in-vehicle devices is essential and should be standardized.

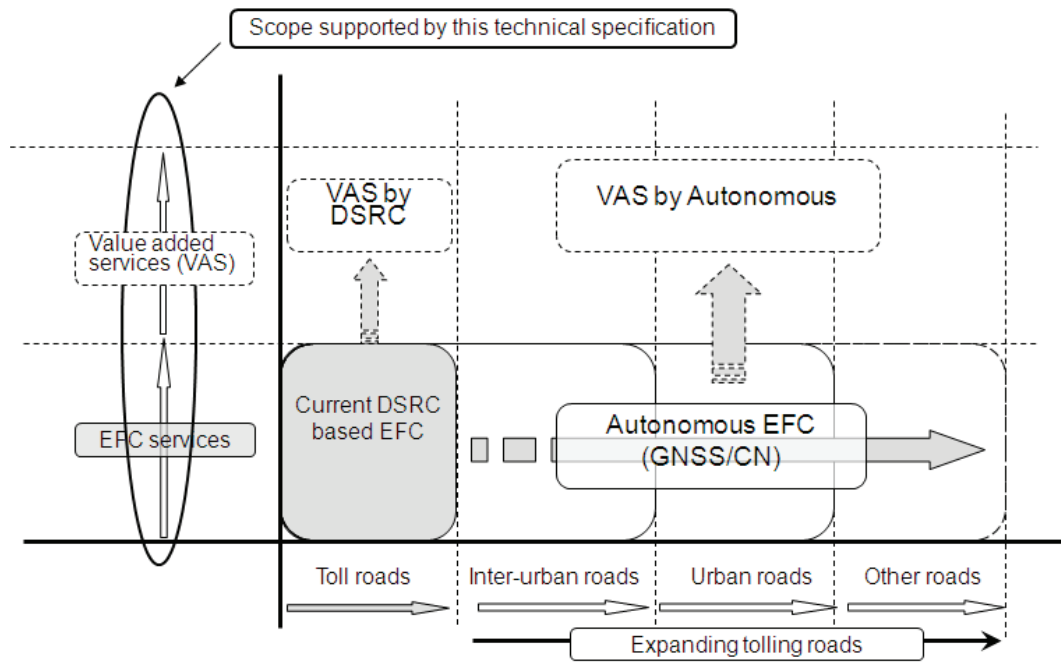

Figure 1 — Image of expanding toll roads and services (Case-3)

Purpose of this Technical Specification

This Technical Specification aims to make it possible for toll road operators to introduce autonomous systems to present non-toll roads by enhancing the functionalities of DSRC-On-Board Equipment (OBE) cooperating with external in-vehicle devices.

As listed below, this Technical Specification defines several tolling models, message sets, and data elements to cope with diversified EFC environment in the main body, as well as data type definition and Protocol Implementation Conformance Statement (PICS) proforma defined in [Annex A](#) and [Annex B](#) respectively. Finally, applicable ITS-services with cooperation of DSRC-OBE and external in-vehicle devices are listed in [Annex E](#) with an example for each of them. This Technical Specification aims at defining the following:

- tolling models with external in-vehicle devices (in main body);
- definitions of message sets and data elements;
- data type definition and PICS proforma (in [Annexes A](#) and [B](#));
- related example and applicable Intelligent Transport System (ITS) services (in [Annex E](#)).

Electronic Fee Collection (EFC) — Interface definition between DSRC-OBE and external in-vehicle devices

1 Scope

This Technical Specification defines an application interface between DSRC-based OBE and external in-vehicle devices to make DSRC-OBE applicable for diversified tolling environment.

The scope of this Technical Specification covers the following items (also shown in [Figure 2](#));

- Definitions of the application interface between DSRC-OBE and external in-vehicle devices (including GNSS, cellular units, CAN interface, etc.).
- Definitions of message sets and data elements on the interface (based on a sets of base standards, such as ISO 14906:2011, ISO/TS 17575, ISO/TS 13141, ISO/TS 12813, and ISO/TS 25110).
- For use in autonomous EFC systems, as well as DSRC-based EFC.
- For use in diversified tolling environment (in toll roads, inner-urban, inter-urban, etc.).
- For use in every kind of DSRC-OBE (based on CEN, UNI, ARIB, TTA, and GB/T).

The following items are out of the scope for this TS:

- Definitions of hardware in the external in-vehicle devices such as GNSS modules, cellular modules, mobile devices, smartphones, etc.
- Definitions of physical interface between DSRC-OBE and external in-vehicle devices such as USB, Bluetooth, etc.
- Definition of any ITS service other than EFC.
- Definition of algorithms for authentication, as well as encryption, and key management.

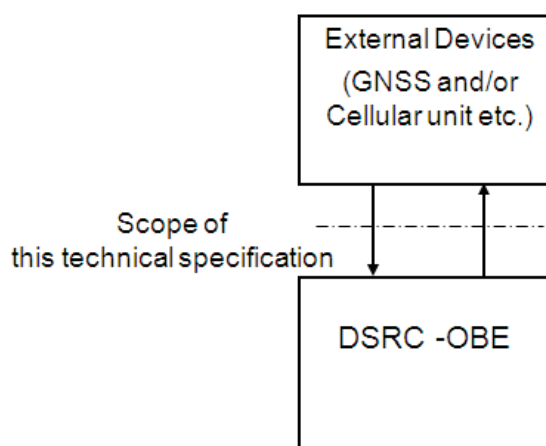

Figure 2 — Scope of this Technical Specification

Applicable DSRC-OBE

When standardizing an application interface between DSRC-OBE and external in-vehicle devices, external in-vehicle devices should be commonly applied for every kind of DSRC-based OBE as shown in [Figure 3](#).

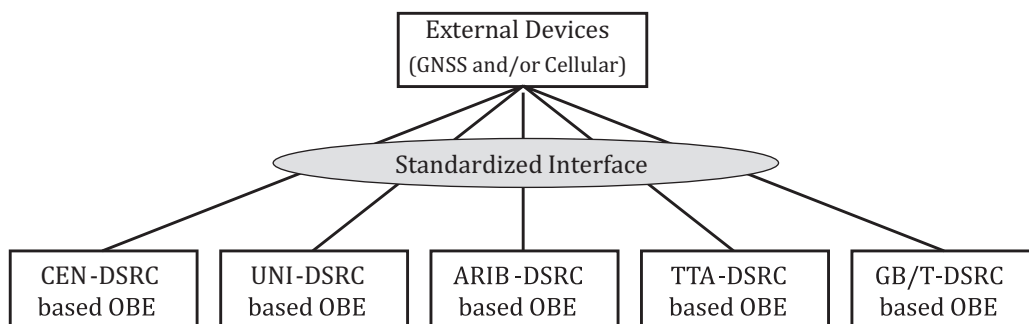

Figure 3 — Applicable DSRC-OBE

The solid and proven DSRC technology makes it possible for DSRC-OBE to have long product-life that enables DSRC-based EFC to be operated still in the future.

On the other hand, each component of external in-vehicle devices has been developed year by year to cope with user's demands on high performance, as well as multi-functional devices; therefore, they have shorter product-life rather than DSRC-OBE. Once an application interface is standardized, DSRC-OBE can be used continuously for diversified EFC environment with enhanced new external in-vehicle devices. See [Figure 4](#).

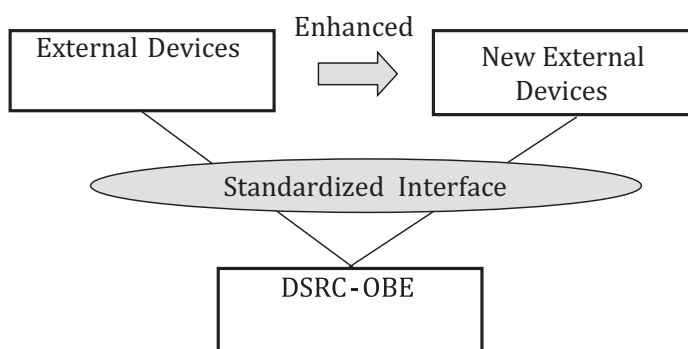

Figure 4 — Applicability for future upgrading

2 Normative references

The following documents, in whole or in part, are normatively referenced in this document and are indispensable for its application. For dated references, only the edition cited applies. For undated references, the latest edition of the referenced document (including any amendments) applies.

ISO/IEC 9798-4:1999, *Information technology — Security techniques — Entity authentication — Part 4: Mechanisms using a cryptographic check function*

ISO 14906:2011, *Electronic Fee Collection — Application interface definition for dedicated short-range communication*

ISO/TS 17575-1:2010, *Electronic Fee Collection — Application interface definition for autonomous systems — Part 1: Charging*

ISO/TS 17575-3:2011, *Electronic Fee Collection — Application interface definition for autonomous systems — Part 3: Context data*

ISO/TS 13141:2010, *Electronic Fee Collection — Localisation augmentation communication for autonomous systems*

ISO/TS 12813:2009, *Electronic Fee Collection — Compliance check communication for autonomous systems*

3 Terms and definitions

For the purposes of this document, the following terms and definitions apply.

3.1

access credentials

trusted attestation or secure module that establishes the claimed identity of an object or application

3.2

attribute

addressable package of data consisting of a single data element or structured sequences of data elements

3.3

autonomous systems

one method of EFC that operate without relying on dedicated road-side infrastructure by employing wide-area technologies such as Global Navigation Satellite Systems (GNSS) and Cellular Communications Networks (CN)

3.4

authenticator

data, possibly encrypted, that is used for authentication

3.5

contract

expression of an agreement between two or more parties concerning the use of the road infrastructure

[SOURCE: ISO 14906:2011, 3.7]

3.6

cryptography

principles, means, and methods for the transformation of data in order to hide its information content, prevent its undetected modification, or prevent its unauthorised use

[SOURCE: ISO 7498-2:1989, 3.3.20, modified]

3.7

data group

class of closely related attributes

3.8

external in-vehicle devices

devices such as mobile phones or dedicated units consisting of GNSS and/or cellular modules that are connected to DSRC-OBE for upgrading the functionalities of it

3.9

issuer

entity responsible for issuing the payment means to the user

3.10

on-board equipment

OBE

equipment located on-board a vehicle including nomadic devices with the function of exchanging information with external systems

Note 1 to entry: The OBE does not need to include payment means.

[SOURCE: ISO 14906:2011, 3.13]

3.11
on-board unit

OBU

minimum component of an *on-board equipment* [3.10], whose functionality always includes at least the support of the DSRC interface

[SOURCE: ISO 14906:2011, 3.14]

3.12
roadside equipment

equipment located along the road, either fixed or mobile

3.13
Toll Service Provider

entity providing toll services in one or more toll domains

Note 1 to entry: In other documents, the terms issuer or contract issuer may be used.

Note 2 to entry: The Toll Service Provider may provide the OBE or may provide only a magnetic card or a smart card to be used with OBE provided by a third party (like a mobile telephone and a SIM card that can be obtained from different parties).

Note 3 to entry: The Toll Service Provider is responsible for the operation (functioning) of the OBE with respect to tolling.

[SOURCE: ISO 17573:2010, 3.23, modified]

3.14
transaction

whole of the exchange of information between two physically separated communication facilities

[SOURCE: ISO 14906:2011, 3.24, modified]

3.15
transaction model

functional model describing the structure of electronic payment transactions

[SOURCE: ISO 14906:2011, 3.25]

4 Symbols and abbreviated terms

For the purpose of this document, the following abbreviations apply throughout the document unless otherwise specified.

ADU	Application Data Unit
APDU	Application Protocol Data Unit
ARIB	Association of Radio Industries and Businesses (Communication standardizing body in Japan)
ASN.1	Abstract Syntax Notation One (ISO/IEC 8824-1)
CAN	Controller Area Network
CCC	Compliance Check Communication (ISO/TS 12813)
CE	Central Equipment
DSRC	Dedicated Short-Range communication
EFC	Electronic Fee Collection

GB/T	Guojia Biaozhun/Tuijian (Chinese “Recommended National Standard”)
GNSS	Global Navigation Satellite Systems
HMI	Human Machine Interface
ICC	Integrated Circuit Card
ITS	Intelligent Transport Systems
LAC	Localization Augmentation Communication (ISO/TS 13141)
OBE	On-board Equipment
OBU	On-board Unit
PMI	Payment Means Issuer
PICS	Protocol Implementation Conformance Statement
RSE	Roadside Equipment
SAM	Secure Application Module
TSP	Toll Service Provider
TTA	Telecommunications Technology Association (Communication standardizing body in Korea)
UNI	Ente Nazionale Italiano di Unificazione
USB	Universal Serial Bus

5 Tolling models with external in-vehicle devices

5.1 General

Multi-functional DSRC-OBE supported with external in-vehicle devices makes current societies smarter with introduction to diversified EFC environment and further ITS services.

There are two kinds of settlement method in EFC, one is on-board account (settlement) system using payment media such as IC card and the other is central account (settlement) system not using payment media. In this Technical Specification, on-board account system in which operational procedure is more complex than central account system is selected as a basic model for diversified EFC.

In the on-board account system, payment media is normally connected to DSRC-OBE and toll amount determined by charging transaction processes between DSRC-OBE and RSE is directly deducted from payment media. On the other hand, payment means can be included in or connected to external in-vehicle devices such as mobile phones. The latter case is shown in [Annex D](#) in which various possible tolling systems other than those mentioned in this clause are introduced.

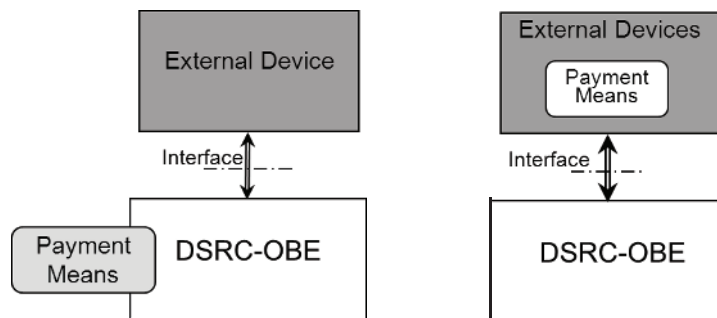

Figure 5 — Connection of payment means (left: in the main body, right: in [Annex D](#))

5.2 Applicable tolling services

Applicable tolling services provided by a combination of DSRC-OBE and external in-vehicle devices are shown in [Table 1](#). The basic DSRC tolling is the present DSRC tolling service as described in [5.3](#) and DSRC-OBE is used as the basic unit for extended tolling services and other ITS services as described in [Annex E](#). As one of extended tolling services, mobile-assisted DSRC tolling performs auto-loading function for payment means via cellular networks as described in [5.4](#).

Universal tolling services both for DSRC tolling and autonomous system described in [5.5](#) that performed with DSRC-OBE and connected external in-vehicle devices are composed of a GNSS receiver, a CN device, and other optional components.

Table 1 — Applicable tolling services with external in-vehicle devices

Tolling services	DSRC-OBE	Components of external in-vehicle devices						References
		GNSS	CN device	HMI	Motion sensors	Digital tachograph	CAN bus unit	
1. Basic DSRC tolling	M							5.3
2. Mobile-assisted DSRC tolling	M		M					5.4
3. Universal tolling	M	M	M	M	M	O	O	5.5

M: Mandatory, O: Option

5.3 Basic DSRC tolling

Present DSRC-OBE used for tolling with payment means and its operating environment is shown in [Figure 5](#). [Figure 5](#) shows prepayment settlement; however, post-payment settlement has the same environment except for reloading operation.

In case of prepayment settlement, the most inconvenient issue for users is reloading to payment means by the terminal installed at the toll plaza or service area along toll roads or contracted shops and so on before payment means getting low balance. See [Figure 6](#).

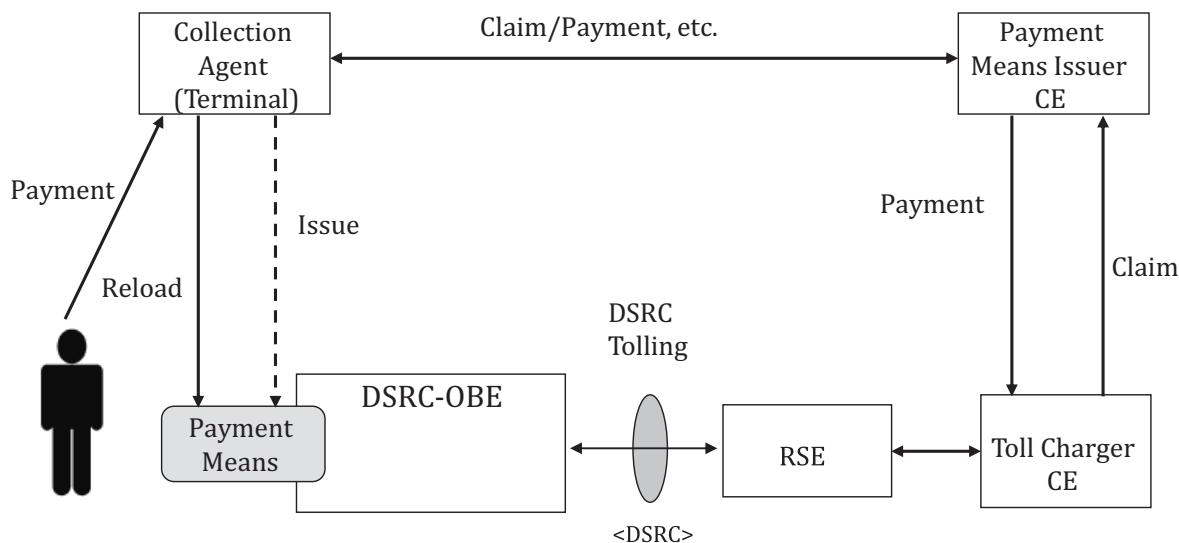

Figure 6 — Basic DSRC tolling

5.4 Mobile-assisted DSRC tolling

5.4.1 Operating environment

An expanded configuration of DSRC-OBE is connected with external in-vehicle devices such as mobile phones used for auto-reloading into the payment means instead of manually reloading through the terminal, which is shown in [Figure 7](#).

This service is performed by DSRC-OBE connected with a mobile phone via an interface. In this system, when the remaining balance in the payment means lowers at the predetermined balance, reload data are transferred from the payment means issuer to DSRC-OBE through a mobile phone and then the payment means balance is updated. A detailed description is shown in [Annex C](#).

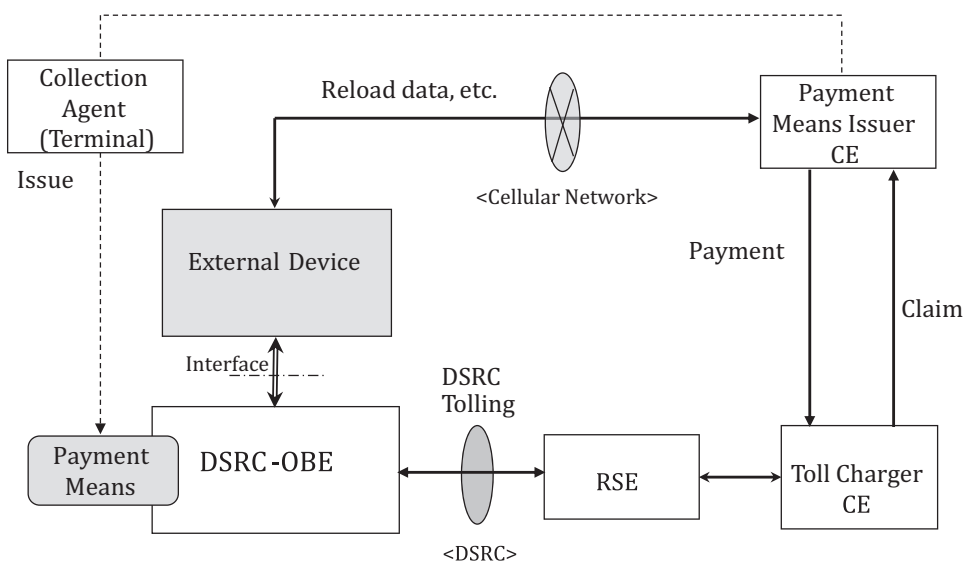

Figure 7 — Mobile-assisted DSRC tolling

5.4.2 Message flows

Application message sequence between external in-vehicle devices and DSRC-OBE after exchanging data for connection and security are as follows and general message flows are shown in [Figure 8](#).

- a) The payment means status is sent from DSRC-OBE to external in-vehicle devices after exchanging data for connection and security.
- b) If account Status in the payment means status is low or empty, external in-vehicle devices send Account update request to the payment means issuer through a cellular network.
- c) The payment means issuer sends Account update containing the predefined value data to external in-vehicle devices if User account is valid after checking.
- d) External in-vehicle devices send Account update to DSRC-OBE, then DSRC-OBE updates payment means.

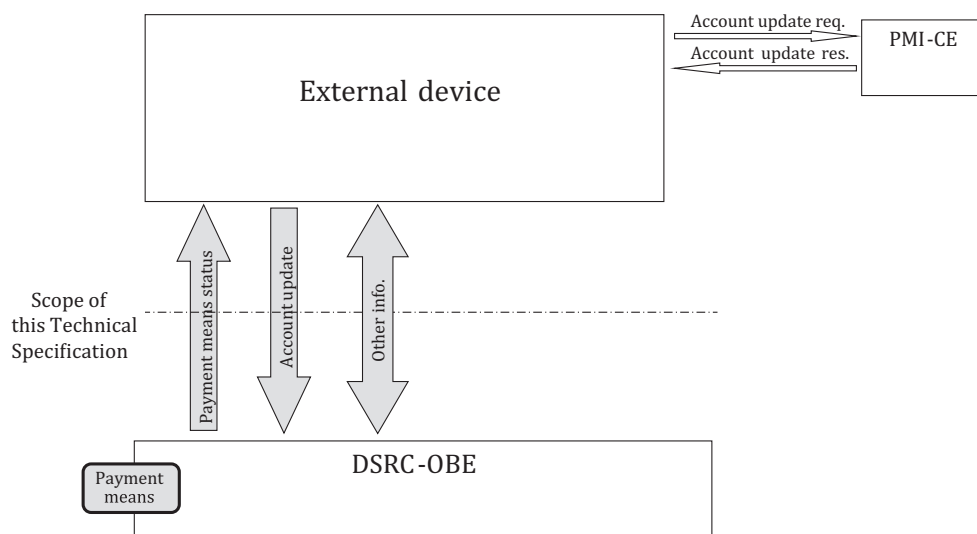

Figure 8 — Message flows for mobile-assisted DSRC tolling

5.5 Universal tolling

5.5.1 Operating environment

The other tolling model in which DSRC-OBE is connected with external in-vehicle devices is Universal tolling which supports both autonomous system and DSRC tolling as shown in [Figure 9](#). In Universal tolling, external in-vehicle devices consist of various components listed in [Table 1](#).

The minimum configuration of external in-vehicle devices is composed of a GNSS receiver, a cellular communication module, and a data processing module. The following components are considered as optional parts for implementation that depends on the requirements of autonomous system:

- a) HMI
- b) Motion sensors
- c) Digital tachograph
- d) CAN bus unit

External in-vehicle devices are connected with the payment means issuer for exchanging reload-related message and with Toll Service Provider for exchanging autonomous tolling-related message defined by ISO/TS 17575-1 through cellular networks.

DSRC-OBE is connected with individual RSEs to communicate transactions for DSRC Tolling, Compliance Checking, and Localization through DSRC.

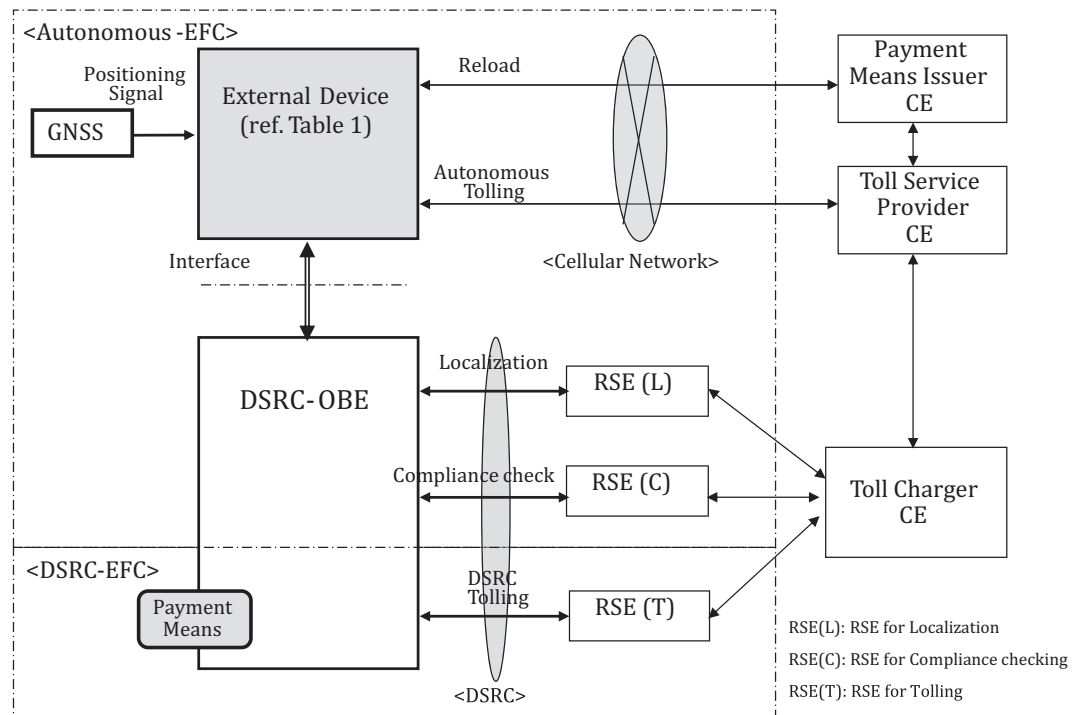

Figure 9 — Universal tolling

5.5.2 Message sequences and flows

Application message flows between external in-vehicle devices and DSRC-OBE after exchanging data for the initial connection and the authentication are shown in Figure 10. With message exchanges between DSRC-OBE and external in-vehicle devices, the following processes are executed.

a) Auto-reloading process for payment means

Payment means status

Account update

b) Payment process

Payment fee

c) Compliance check process

Compliance check data (C.C data)

d) Localization process

Localization data (LAC data)

e) HMI process etc.

Others

Message exchanges between external in-vehicle devices and the payment means issuer are Account update request and response relating with Auto-reloading of payment means. Message exchanges between external in-vehicle devices and the Toll Service Provider are Charge report and Context data defined by ISO/TS 17575-3.

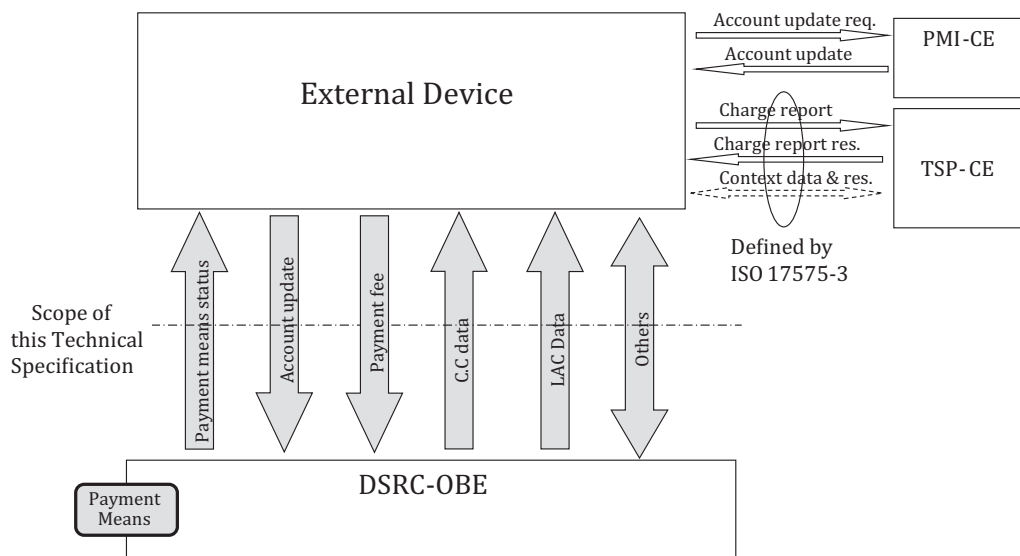

Figure 10 — Message flows for Universal tolling

6 Message sets

6.1 General

Message sets exchanged on the interface between DSRC-OBE and external in-vehicle devices are listed in [Table 2](#) and each data element id defined in the latter sub-clauses.

Table 2 — Message sets

Message sets		Description	References
Name	Data elements		
1. Payment means status	paymentMode	Defines payment mode of payment means	Newly defined
	accountStatus	Indicates card status such as positive value for tolling or not, and other information	ISO/TS 17575-1
	paymentMeansBalance (valueData)	Indicates balance (value) data of payment means	ISO 14906:2011
	paymentMeans	Defines the characteristics of payment means.	ISO 14906:2011
2. Payment fee	paymentFeeAmount	Defines the value of the fee being charged for the service.	ISO 14906:2011
	paymentFeeUnit	Defines the unit in which the fee is expressed.	ISO 14906:2011
3. Account update	reloadAccount	Instructs the OBE application to either top up the respective type of account with a predefined value or not.	ISO/TS 17575-1
	setAccount	Sets a specific value to the account.	ISO/TS 17575-1
	addToAccount	Adds a specific value to the account	ISO/TS 17575-1

Table 2 (continued)

Message sets		Description	References
Name	Data elements		
4. Compliance checking data (CCCAttributes)	timeOfCCCRecord	The time at which CCC transaction occurred.	ISO/TS 17575-1
	axlesHistory	Used to check if the change of the declared number of axles occurred during the trip, e.g. just before a CCC.	ISO/TS 12813
	communicationStatus	Used to check if the toll data communication is operational (not tampered with).	ISO/TS 12813
	gnssStatus	Used to check if GNSS reception is operational (not tampered with).	ISO/TS 12813
	distRecStatus	Used to check distance recording accuracy using two successive beacon, or quality of the odometer's signal.	ISO/TS 12813
	activeContext	Used to check if the current context(s) are active in the OBE.	ISO/TS 12813
	obeHistory	Used to prevent fraud by incorrect deactivation while in transit.	ISO/TS 12813
5. Localization data (LacData)	LACOperator	Identify the organization that operates LAC.	ISO/TS 13141
	rSEId	Identify an operator-specific identification of the RSE.	ISO/TS 13141
	latitude	The latitudinal coordinate of the centre of the road surface covered by the specific LAC implementation.	ISO/TS 13141
	longitude	The longitudinal coordinate of the centre of the road surface covered by the specific LAC implementation.	ISO/TS 13141
	Altitude	The altitudinal coordinate of the centre of the road surface covered by the specific LAC implementation.	ISO/TS 13141
	tollCharger	Identify the Toll Charger that owns the toll scheme for which LAC is operated.	ISO/TS 13141
	chargeObject	Identify charge object for which LAC is operated, according to the local definition of the Toll Charger owning the respective toll scheme, e.g. road section, passage of cordon.	ISO/TS 13141 ISO/TS 17575-1
	distanceToObject	The distance in metres to the charge object as identified by the element chargeObject, from the point of operation of the LAC.	ISO/TS 13141
	lACTime	The time at which the LAC transaction occurred.	ISO/TS 13141
	mAC1	Security-related data regarding the LacData.	ISO/TS 13141
	mAC2	Security-related data regarding the LacData.	ISO/TS 13141

6.2 Payment means status

6.2.1 Payment means status

Payment means have the following status information which is checked for payment mode and validation before payment process.

6.2.2 paymentMode

Payment means have the following respective payment mode as defined and operated by Issuers.

```
Pre-payment (prepaid card)
Post-payment (credit card or other post-pay card)
immediate payment (bank card)
others
```

6.2.3 accountStatus

In case of pre-payment, external in-vehicle devices can get the status of the respective account from DSRC-OBE. The respective data element `accountStatus` can have the following values:

```
ok, i.e. contains a positive value above a defined threshold
low, i.e. contains a positive value below a defined threshold
empty, i.e. contains the value zero
negative, i.e. contains a value below zero
```

6.2.4 paymentMeansBalance (valueData)

In case of pre-payment, external in-vehicle devices have an option to get the payment means balance (value data) from the payment means directly by sending the read command to it through DSRC-OBE.

6.2.5 paymentMeans

In case of post-payment, the data element `paymentMeans` is a unique identification of an individual road user account. The respective data type is defined in ISO 14906. It consists of the following data elements which indicate the issue's specified restrictions, on the geographic usage and service allowed for the applications.

```
personalAccountNumber
paymentMeansExpiryDate
paymentMeansUsageControl
```

6.3 Payment fee

6.3.1 PaymentFee

The fee (toll, charge, or fare) is defined as requested by the service provider for the service provided or to be provided.

6.3.2 paymentFeeAmount

The data element `paymentFeeAmount` is the value of the fee being charged for the service.

6.3.3 paymentFeeUnit

The data element `paymentFeeUnit` is the unit in which the fee is expressed.

6.4 Account update

6.4.1 AccountUpdate

In case of Pre-payment, the account of payment means can be updated by PMI-CE through a Cellular network. The respective data element `AccountUpdate` consists of the following three parts providing three options for updating the account:

Either a predefined value is added to the current balance (through the data element `reloadAccount`) or the new balance is explicitly transmitted (through the data element `setAccount`). The third option adds a given quantity to the account (through the data element `addToAccount`). The update sets limits in credit, distance, time (defining a point of time until expiry), duration (defining duration until expiry), or a number of detected events.

6.4.2 reloadAccount

A predefined value is added to the current balance through the data element `reloadAccount`. The predefined value must be set in advance, either by the initial configuration process for the frontend or using the update mechanism.

Security measures can be applied to the data element `reloadAccount` using the element `reloadAuthenticator`.

6.4.3 setAccount

The new balance is explicitly transmitted through the data element `setAccount`. The Data element `setAccount` is of type `newAccountLimit`, which sets the account to a specific value.

Security measures can be applied to the data element `newAccount` using the element `newAuthenticator`.

6.4.4 addToAccount

The third option adds a given quantity to the account through the data element `addToAccount`. The Data element `addToAccount` is of type `AddToAccount`, which adds a specific value to the account.

Security measures can be applied to the data element `addToAccount` using the element `addAuthenticator`.

6.5 Compliance checking data (CCCAttributes)

The data in the structure `CCCAttributes` are defined in and imported from ISO/TS 17575-1 and ISO/TS 12813.

6.6 Localization data (LacData)

The data in the structure `LacData` are defined in and imported from ISO/TS 13141.

7 Security aspects

7.1 General

The interface between DSRC-OBE and external in-vehicle devices is exposed to being attacked so the following requirements should be taken into account (referring to requirements listed in CEN/TS 16439 EFC Security Framework):

- data exchange shall only be done between authenticated entities for the respective data (RQ.IF.20);

- data exchange shall guarantee data confidentiality (RQ.IF.10);
- data exchange shall guarantee data integrity (RQ.IF.11).

To meet the above requirements, mutual authentication between DSRC-OBE and external in-vehicle devices, an encryption for exchanged data, and message authentication for manipulation checking should be the essential security measures.

A conformance test of DSRC-OBE relating to security measures should be conducted with being connected to external in-vehicle devices, as well as implemented EFC functions required both for DSRC tolling and autonomous systems.

7.2 OBE interface profile

Mutual authentication between DSRC-OBE and external in-vehicle devices should be three-way authentication based on ISO/IEC 9798-4, and an encryption should be applied for exchanged data on the interface. However, definition of algorithm for authentication and encryption and key management should be out of scope of this Technical Specification. See [Figure 11](#).

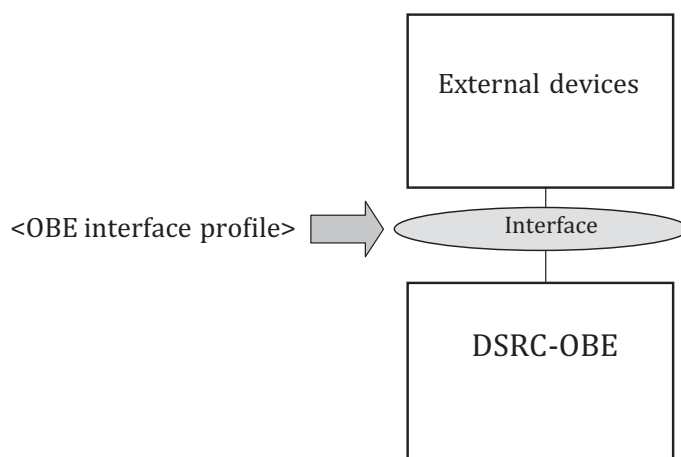

Figure 11 — OBE interface profile

Annex A (normative)

Data type specification

This clause contains the ASN.1 definition of

- the data types related to the Tolling models described in [Clause 5](#),
- the data types related to the Message sets as specified in [Clause 6](#),
- the ASN.1 container types for ISO Layer 7,

using the Abstract Syntax Notation One (ASN.1) technique according to ISO/IEC 8824-1. The packed encoding rules according to ISO/IEC 8825-2 shall be applied.

```
EfcDsrcObeExtDevices {iso(1) standard(0) 16785 version1(1)}
DEFINITIONS AUTOMATIC TAGS
 ::= BEGIN

IMPORTS
TollCharger, AccountStatus, ChargeObjectId, ReloadAccount, NewAccountLimit, AddToAccount
FROM ChargingModule {iso standard 17575 modules(0) efc(0) version(1)}

-- Imports data attributes and elements from ISO 17575-1

Latitude, Longitude, VehicleAxlesHistory, CommunicationStatus, GnssStatus,
DistanceRecordingStatus, ActiveContext, OBEStatusHistory
FROM CccModule {iso standard 12813 modules(0) ccc(0) version(1)}

-- imports data attributes and elements from ISO 12813

Time
FROM DSRCDATA {iso standard 14906 modules (0) dsrc (1) version (1)}

PaymentMeansBalance, PaymentMeans, PayUnit, DateAndTime, Provider
FROM EfcModule {iso standard 14906 modules(0) efc(0) version(1)};

-- imports data attributes and elements from the efc module of ISO 14906:2011

-- Note the followings are the definitions of the Message sets

-----
-- Level 1 --
-----

PaymentMeansStatus ::= SEQUENCE{
    paymentMode                Int2,
    accountStatus              AccountStatus,
    paymentMeansBalance        PaymentMeansBalance,
    paymentMeans                PaymentMeans
}

PaymentFee ::= SEQUENCE{
    paymentFeeAmount           Int2,
    paymentFeeUnit             PayUnit
}

AccountUpdate ::= CHOICE {
    reloadAccount              ReloadAccount,
    setAccount                  NewAccountLimit,
    addToAccount                AddToAccount
}

```

```
CCCAttributes ::= SEQUENCE {
    timeOfCCCRecord      DateAndTime OPTIONAL,
    axlesHistory         VehicleAxlesHistory OPTIONAL,
    commStatus           CommunicationStatus OPTIONAL,
    gnssStatus           GnssStatus OPTIONAL,
    distRecStatus        DistanceRecordingStatus OPTIONAL,
    activeContext        ActiveContext OPTIONAL,
    obeHistory           OBEStatusHistory OPTIONAL
}
```

```
LacData ::= SEQUENCE{
    lacOperator          Provider,
    rSEId               Int2,
    latitude             Latitude,
    longitude            Longitude,
    altitude             INT2Signed,
    tollCharger         TollCharger,
    chargeObject        ChargeObjectId,
    distanceToObject    INT2Signed,
    lacTime              Time,
    mAC1                OCTET STRING (SIZE (8)),
    mAC2                OCTET STRING (SIZE (8))
}
```

```
-----
-- Level 2 --
-----
```

-- NOTE: The following are the definitions of the Payment related data elements

```
SignedValue ::= CHOICE {
    positive          INTEGER (0..8388607),
    negative          INTEGER (-8388608..-1)
}
```

```
Int2 ::= INTEGER(0..65535)
```

```
INT2Signed ::= INTEGER (-32768..32767)
```

END

Annex B (normative)

Protocol Implementation Conformance Statement proforma

B.1 Introduction

This clause contains the Protocol Implementation Conformance Statements (PICS) proforma to be used for Front-End implementation of the charge report protocol defined in [Clause 6](#) and [Annex A](#).

B.2 Message sets

Element	Status	Implemented
Payment means status	optional	Yes/No
Payment fee	optional	Yes/No
Account update	optional	Yes/No
Compliance checking data (CCCAttribute)	optional	Yes/No
Localization data (LacData)	optional	Yes/No
Other data	optional	Yes/No

B.3 Data elements

B.3.1 Payment means status

Element	Status	Implemented
paymentMode	optional	Yes/No
accountStatus	optional	Yes/No
paymentMeansBalance (Value data)	optional	Yes/No
paymentMeans	optional	Yes/No

B.3.2 Payment fee

Element	Status	Implemented
paymentFeeAmount	optional	Yes/No
paymentFeeUnit	optional	Yes/No

B.3.3 Account update

Element	Status	Implemented
reloadAccount	optional	Yes/No
setAccount	optional	Yes/No
addToAccount	optional	Yes/No

B.3.4 Compliance checking data

Account type	Status	Implemented
timeOfCCCRecord	optional	Yes/No
axleHistory	optional	Yes/No
commStatus	optional	Yes/No
gnssStatus	optional	Yes/No
disRecStatus	optional	Yes/No
activeContext	optional	Yes/No
obeHistory	optional	Yes/No

B.3.5 Localization data

Account type	Status	Implemented
LACOperator	optional	Yes/No
rSEId	optional	Yes/No
latitude	optional	Yes/No
longitude	optional	Yes/No
altitude	optional	Yes/No
tollCharger	optional	Yes/No
chargeObject	optional	Yes/No
DistanceToObject	optional	Yes/No
lACTime	optional	Yes/No
mAC1	optional	Yes/No
mAC2	optional	Yes/No

Annex C (informative)

Mobile-assisted DSRC tolling in Korea

C.1 General

This chapter describes the services and procedures used for ICC reload transaction, via Bluetooth communication between OBU and a mobile phone in Korea. See [Figure C.1](#).

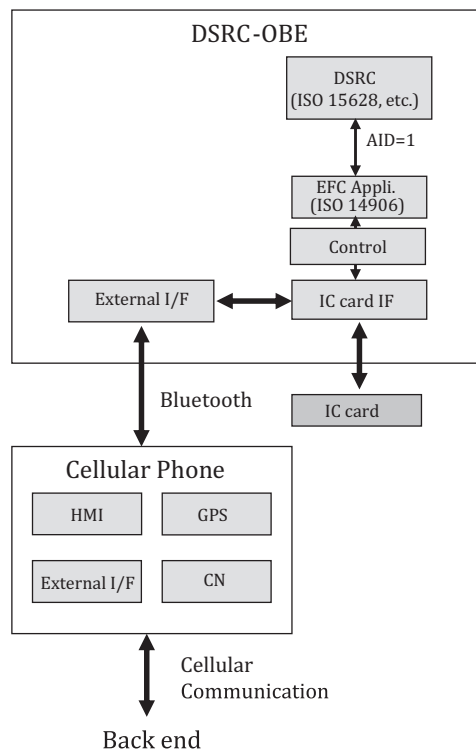

Figure C.1 — Configuration of Bluetooth OBU service

A Bluetooth OBU mainly consists of a DSRC communication unit, a Bluetooth communication unit, an ICC interface unit, and an HMI unit. After registering the Bluetooth OBU to the driver's mobile phone, several services are possible such as

- ICC reload,
- ICC balance low limit setting (In case of lack of balance, voice and message inform),
- Reload amount of money setting (auto reload),
- ICC debit notice (voice and message inform), and
- ICC transaction log query (up to 50), and etc.

In addition to the 5 % to 20 % debit discount in the ETC lane, 3 % credit overcharging benefit is given if the Bluetooth OBU is used at reload transaction.

C.2 Services description

Once Bluetooth communication link is set up between OBU and a mobile phone, the mobile phone sends ICC APDU command directly to ICC and receives ICC response back, so that all kinds of ICC-related transaction can take place such as ICC reload, ICC debit query, ICC transaction log query, ICC info query, and so on.

C.3 Reload transaction

ICC reload procedure is as follows:

- a) Driver runs ICC reload application on mobile phone.
- b) Mobile phone links with OBU via Bluetooth communication.
- c) Mobile phone links with backend system via cellular network (user's account, Host SAM).
- d) Driver inputs the amount of money for ICC reload on the mobile phone.
- e) According to reload transaction flow in application software, the mobile phone sends ICC command to OBU and SAM command to backend Host SAM.
- f) OBU transfers its command to ICC. If any of ICC response is returned, OBU transfers its response to mobile phone.
- g) Backend system transfers its command to Host SAM. If any of Host SAM responses is returned, backend system transfers its response to the mobile phone.
- h) After a successful ICC reload transaction is finally done, the mobile phone informs the driver of the transaction result by using voice and message.

C.4 Debit transaction

If ICC debit transaction takes place at the ETC toll plaza, regardless of correct or incorrect transaction, this event is delivered from OBU to a mobile phone via Bluetooth communication. Because the Bluetooth link between OBU and the mobile phone is broken in normal situation, OBU attempts to link setup with the mobile phone and delivers the ICC debit transaction result to the mobile phone. Afterwards, the mobile phone informs the driver of the transaction result by using voice message.

C.5 ASN.1-module

```
OBU-MessageType ::= CHOICE {
    obu-version-request          [0]    OBU-version-request,
    obu-version-response        [1]    OBU-version-response,
    obu-info-request            [2]    OBU-info-request,
    obu-info-response           [3]    OBU-info-response,
    obu-register-inform         [4]    OBU-register-inform,
    obu-register-acknowledge    [5]    OBU-register-acknowledge,
    bt-zone-exit-inform        [6]    BT-zone-exit-inform,
    bt-zone-exit-acknowledge    [7]    BT-zone-exit-acknowledge,
    bt-zone-entry-inform       [8]    BT-zone-entry-inform,
    bt-zone-entry-acknowledge   [9]    BT-zone-entry-acknowledge,
}
ICC-MessageType ::= CHOICE {
    icc-power-on-request        [0]    ICC-power-on-request,
    icc-power-on-response      [1]    ICC-power-on-response,
    icc-power-off-request       [2]    ICC-power-off-request,
    icc-power-off-response     [3]    ICC-power-off-response,
    icc-apdu-exchange-request   [4]    ICC-APDU-exchange-request,
    icc-apdu-exchange-response [5]    ICC-APDU-exchange-response,
    icc-apdu-exchange-stop-request [6] ICC-APDU-exchange-stop-request,
    icc-apdu-exchange-stop-response [7] ICC-APDU-exchange-stop-response,
```

```
icc-info-query-request      [8] ICC-info-query-request,  
icc-info-query-response    [9]  ICC-info-query-response,  
icc-reload-query-request   [10] ICC-reload-query-request,  
icc-reload-query-response  [11] ICC-reload-query-response,  
}
```

Annex D (informative)

Other possible tolling models

D.1 General

As essential tolling models performed by DSRC-OBE connected to external in-vehicle devices that are described in [Clause 5](#), other possible tolling models are introduced in [Annex D](#). Furthermore, mobile payment and “Touch and Go” payment without DSRC-OBE are also introduced for references.

Touch and Go payment method, simplified EFC performed with transaction processing between payment means and roadside reader, is introduced widely in Asian countries because of low installation cost and no-OBE required.

D.2 DSRC-assisted mobile payment

Anonymous mobile payment is performed by connecting DSRC-OBE and a mobile phone with a payment function that has prevailed in the markets.

Functions and process flows are described below.

- a) Charge amount is determined by transaction exchanges between DSRC-OBE and RSE.
- b) Determined charge amount is transferred to external in-vehicle devices.
- c) Charge amount is deducted from payment means imbedded in external in-vehicle devices.
- d) External in-vehicle devices transfer payment information to DSRC-OBE and mobile service provider through CN as well.

Anonymous payment is performed because payment should be done for Toll charger without identifying user directly. See [Figures D.1](#) and [D.2](#).

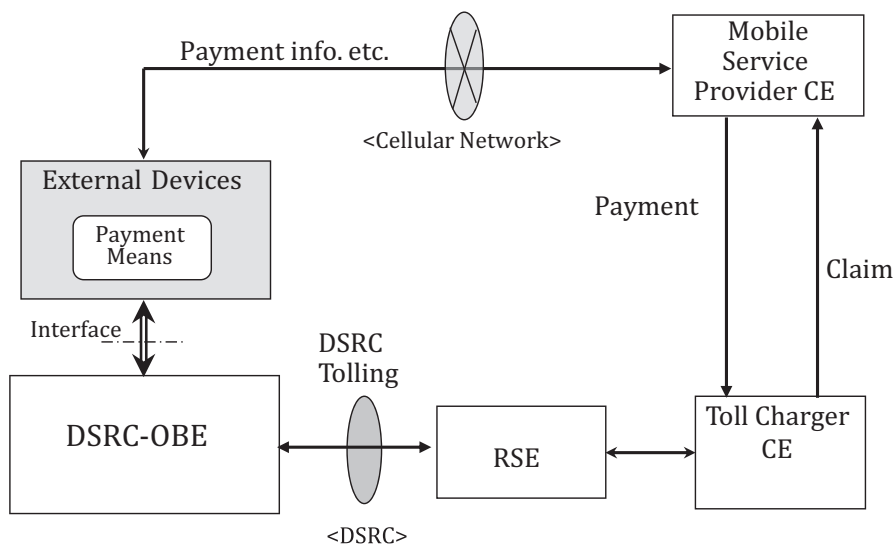

Figure D.1 — DSRC-assisted mobile payment

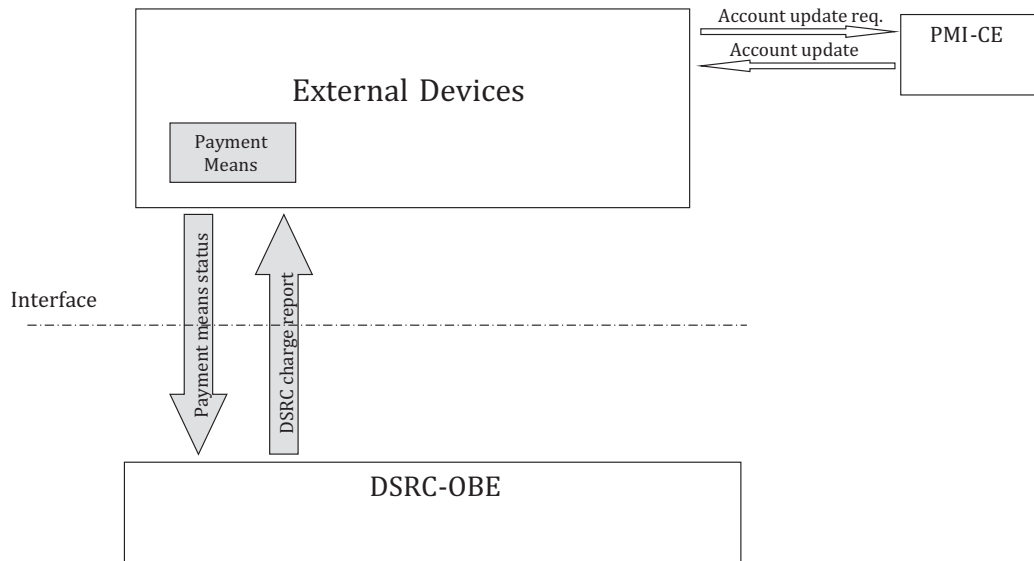

Figure D.2 — Message flows for DSRC-assisted mobile payment

D.3 Mobile payment

Mobile payment is simplified DSRC-assisted mobile payment and the functions and process flows are described below and shown in [Figure D.3](#).

- a) Charge amount is determined by transaction exchanges between external in-vehicle devices and RSE through NFC interface.
- b) Determined charge amount is deducted from payment means imbedded in external in-vehicle devices.
- c) External in-vehicle devices transfer payment information to mobile service provider through CN.

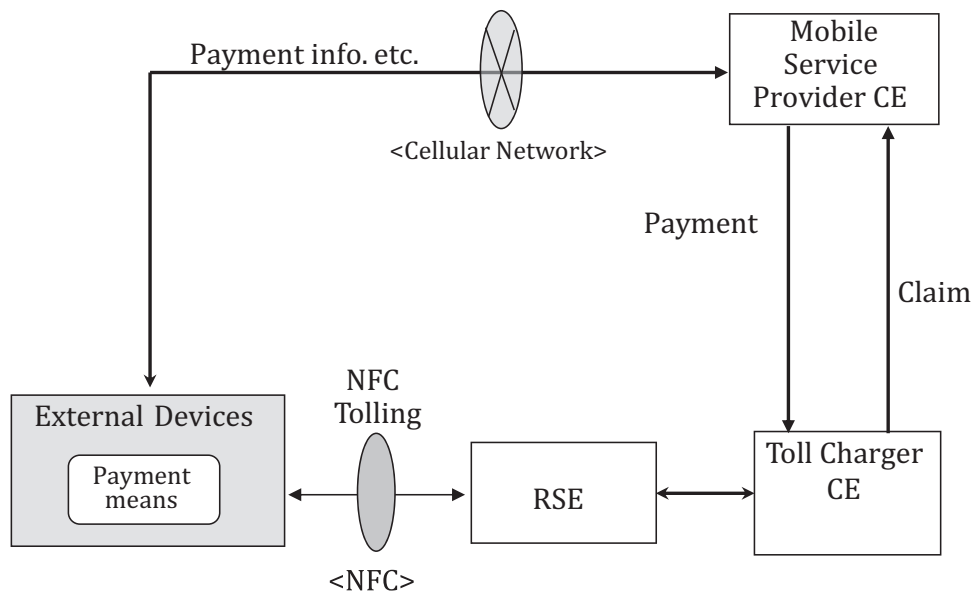

Figure D.3 — Mobile payment

D.4 Touch and Go payment

The most simplified EFC is Touch and Go payment in which user handles the payment means to touch the RSE. Payment means should have NFC interface. Touch and Go payment is introduced in Asian countries such as Malaysia, Korea, etc. as simplified EFC along with on-board account EFC.

In case of low balance or near low balance, payment means should be reloaded by the terminal installed at a toll plaza or service area along toll roads or contracted shops and so on. See [Figure D.4](#).

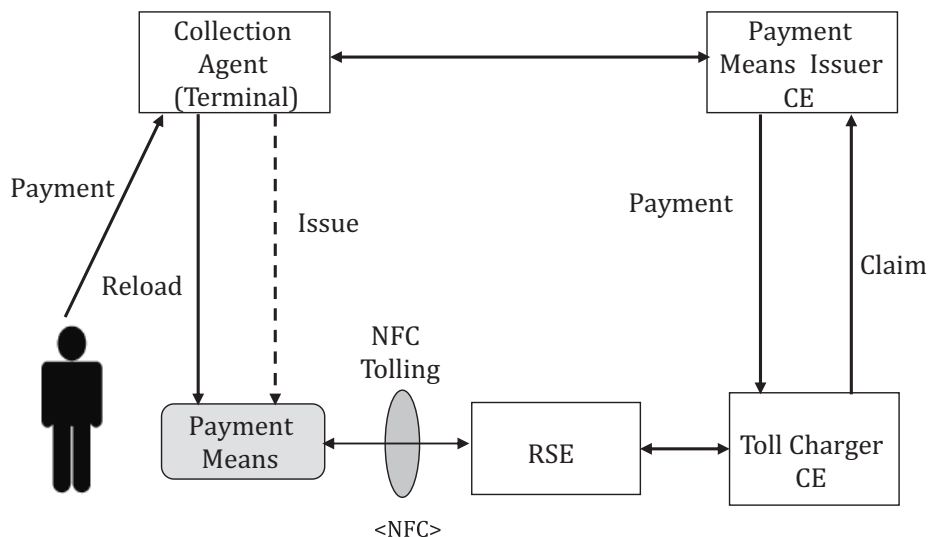

Figure D.4 — Touch and Go payment

Annex E (informative)

Applicable ITS services

E.1 Applicable ITS services with external in-vehicle devices

Applicable ITS services supported by several combinations of DSRC-OBE and external in-vehicle devices are shown in [Table E.1](#). As an example, ITS services in Japan are introduced briefly hereinafter.

Table E.1 — Applicable ITS services with external in-vehicle devices

ITS services		DSRC-OBE	Components of external in-vehicle devices ^a							Adapted for (plan)
			GNSS	CN module	HMI	Motion sensors	Digital tachograph	Driver records device	Driving licence reading device	
1. Tolling services	Basic DSRC tolling	M								Globally
	Mobile-assisted DSRC tolling	M		M						KR-ETC
	Universal tolling	M	M	M	M	M	O			O Globally
	DSRC-assisted mobile payment	M		M						
2. Road traffic information	Probe information	M	M			M				JP-ITS
	Dynamic route guidance	M			M					JP-ITS
	Traffic information	M			M					JP-ITS
3. Safety assisting	Curve speed warning	M			M					JP-ITS
	Obstacle detection warning	M			M					JP-ITS

CAN: Controller Area Network, **EV:** Electric Vehicle, **JP:** Japan, **KR:** Korea, **TARV:** Telematics Application for Regulated commercial Vehicles. M: Mandatory, O: Option

^a Exclude software module such as Proxy for tolling and any application module.

Table E.1 (continued)

ITS services		DSRC-OBE	Components of external in-vehicle devices ^a							Adapted for (plan)	
			GNSS	CN module	HMI	Motion sensors	Digital tachograph	Driver records device	Driving licence reading device		CAN bus unit
4.Regulated commercial operations	Remote tachograph monitoring	M	M	M			M				(TARV)
	Driver work records	M	M	M				M			(TARV)
	Vehicle speed monitoring	M	M	M					M		(TARV)
5.EV management	EV charge amount monitoring	M	M	M						M	JP-EV
	Charge station guidance	M	M	M							JP-EV
6.Others	Drive through payment	M			M						(JP-ITS)

CAN: Controller Area Network, **EV:** Electric Vehicle, **JP:** Japan, **KR:** Korea, **TARV:** Telematics Application for Regulated commercial Vehicles. M: Mandatory, O: Option

^a Exclude software module such as Proxy for tolling and any application module.

E.2 ITS service in Japan

ITS services have been introduced with a step-by-step approach in Japan since the early 1990s. The first popular service is road guidance service provided by a car navigation device which provides road information to drivers for cruise assistance. The next service is Vehicle Information and Communication System (VICS) which provides traffic information and other road-related information on a car navigation device for drivers via DSRC using 2,45 GHz band. The third service is ETC which has prevailed nationwide now, and then those services are integrated by the new DSRC-OBE model which has dual-DSRC access port, one is for ETC and the other is for the new VICS using 5,8 GHz band same as ETC.

The system diagram of the integrated ITS services in Japan is shown in [Figure E.1](#) and the internal diagram of a new DSRC-OBE is shown in [Figure E.2](#). New ITS services in Japan are shown in [Figure E.3](#).

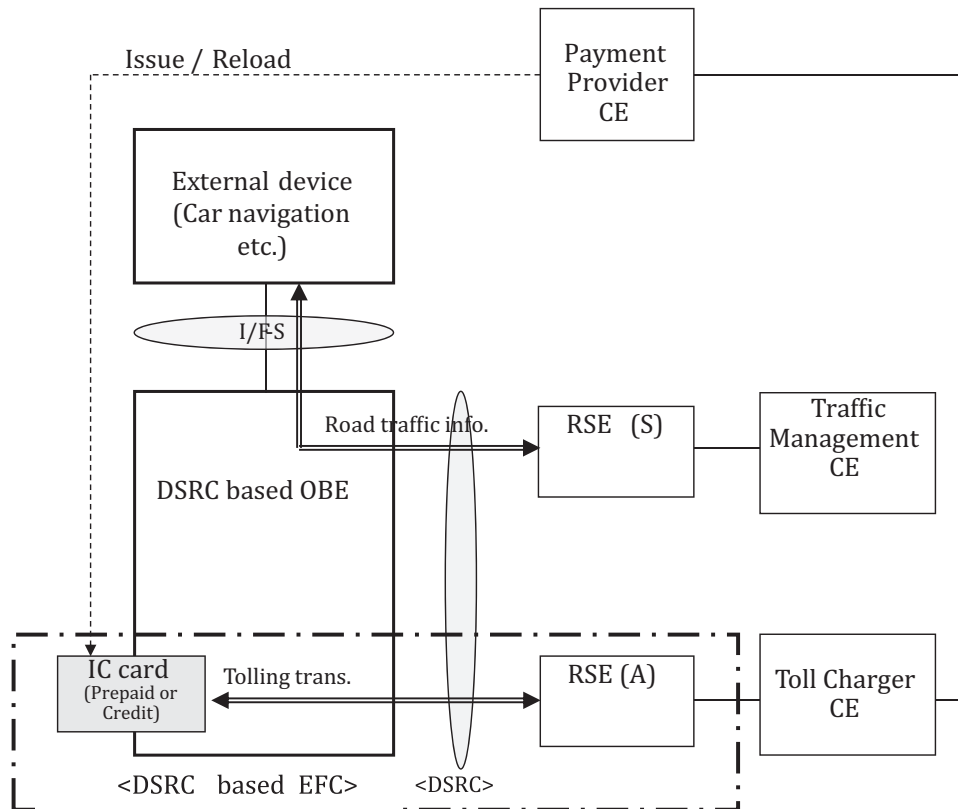

Key

- RSE (A) support DSRC-based tolling communication
- RSE (S) support road traffic information

Figure E.1 — System diagram of the integrated ITS services in Japan

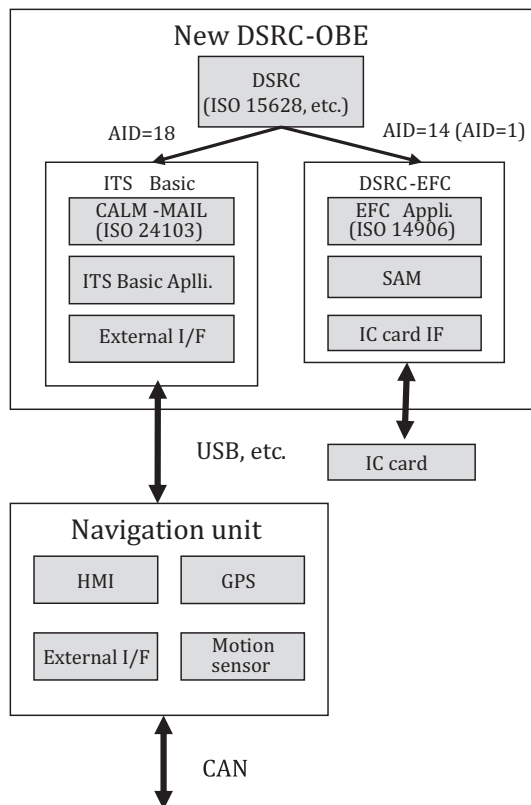

Figure E.2 — Internal diagram of new DSRC-OBE



Figure E.3 — New ITS services in Japan

Bibliography

- [1] CEN/TS 16439:2012¹⁾, *Electronic Fee Collection — Security Framework*
- [2] ISO/TS 25110:2013, *Electronic fee collection — Interface definition for on-board account using integrated circuit card (ICC)*

1) ISO/TS 19299 with the same title is a new project and under development.

British Standards Institution (BSI)

BSI is the national body responsible for preparing British Standards and other standards-related publications, information and services.

BSI is incorporated by Royal Charter. British Standards and other standardization products are published by BSI Standards Limited.

About us

We bring together business, industry, government, consumers, innovators and others to shape their combined experience and expertise into standards-based solutions.

The knowledge embodied in our standards has been carefully assembled in a dependable format and refined through our open consultation process. Organizations of all sizes and across all sectors choose standards to help them achieve their goals.

Information on standards

We can provide you with the knowledge that your organization needs to succeed. Find out more about British Standards by visiting our website at bsigroup.com/standards or contacting our Customer Services team or Knowledge Centre.

Buying standards

You can buy and download PDF versions of BSI publications, including British and adopted European and international standards, through our website at bsigroup.com/shop, where hard copies can also be purchased.

If you need international and foreign standards from other Standards Development Organizations, hard copies can be ordered from our Customer Services team.

Subscriptions

Our range of subscription services are designed to make using standards easier for you. For further information on our subscription products go to bsigroup.com/subscriptions.

With **British Standards Online (BSOL)** you'll have instant access to over 55,000 British and adopted European and international standards from your desktop. It's available 24/7 and is refreshed daily so you'll always be up to date.

You can keep in touch with standards developments and receive substantial discounts on the purchase price of standards, both in single copy and subscription format, by becoming a **BSI Subscribing Member**.

PLUS is an updating service exclusive to BSI Subscribing Members. You will automatically receive the latest hard copy of your standards when they're revised or replaced.

To find out more about becoming a BSI Subscribing Member and the benefits of membership, please visit bsigroup.com/shop.

With a **Multi-User Network Licence (MUNL)** you are able to host standards publications on your intranet. Licences can cover as few or as many users as you wish. With updates supplied as soon as they're available, you can be sure your documentation is current. For further information, email bsmusales@bsigroup.com.

BSI Group Headquarters

389 Chiswick High Road London W4 4AL UK

Revisions

Our British Standards and other publications are updated by amendment or revision.

We continually improve the quality of our products and services to benefit your business. If you find an inaccuracy or ambiguity within a British Standard or other BSI publication please inform the Knowledge Centre.

Copyright

All the data, software and documentation set out in all British Standards and other BSI publications are the property of and copyrighted by BSI, or some person or entity that owns copyright in the information used (such as the international standardization bodies) and has formally licensed such information to BSI for commercial publication and use. Except as permitted under the Copyright, Designs and Patents Act 1988 no extract may be reproduced, stored in a retrieval system or transmitted in any form or by any means – electronic, photocopying, recording or otherwise – without prior written permission from BSI. Details and advice can be obtained from the Copyright & Licensing Department.

Useful Contacts:

Customer Services

Tel: +44 845 086 9001

Email (orders): orders@bsigroup.com

Email (enquiries): cservices@bsigroup.com

Subscriptions

Tel: +44 845 086 9001

Email: subscriptions@bsigroup.com

Knowledge Centre

Tel: +44 20 8996 7004

Email: knowledgecentre@bsigroup.com

Copyright & Licensing

Tel: +44 20 8996 7070

Email: copyright@bsigroup.com



...making excellence a habit.™