

PD ISO/TS 14198:2012



BSI Standards Publication

# Road vehicles — Ergonomic aspects of transport information and control systems — Calibration tasks for methods which assess driver demand due to the use of in-vehicle systems

NO COPYING WITHOUT BSI PERMISSION EXCEPT AS PERMITTED BY COPYRIGHT LAW

*raising standards worldwide™*



### **National foreword**

This Published Document is the UK implementation of ISO/TS 14198:2012.

The UK participation in its preparation was entrusted to Technical Committee AUE/12, Safety related to occupants.

A list of organizations represented on this committee can be obtained on request to its secretary.

This publication does not purport to include all the necessary provisions of a contract. Users are responsible for its correct application.

© The British Standards Institution 2012

Published by BSI Standards Limited 2012

ISBN 978 0 580 69659 6

ICS 13.180; 43.040.15

**Compliance with a British Standard cannot confer immunity from legal obligations.**

This Published Document was published under the authority of the Standards Policy and Strategy Committee on 30 November 2012.

### **Amendments issued since publication**

<b>Amd. No.</b>	<b>Date</b>	<b>Text affected</b>
-----------------	-------------	----------------------

---

TECHNICAL  
SPECIFICATION

**ISO/TS**  
**14198**

First edition  
2012-11-15

---

---

**Road vehicles — Ergonomic aspects  
of transport information and control  
systems — Calibration tasks for  
methods which assess driver demand  
due to the use of in-vehicle systems**

*Véhicules routiers — Aspects ergonomiques des systèmes  
d'information et de contrôle du transport — Tâches de calibration  
pour méthodes qui évaluent la distraction du conducteur due à  
l'utilisation des systèmes embarqués*



Reference number  
ISO/TS 14198:2012(E)

© ISO 2012



**COPYRIGHT PROTECTED DOCUMENT**

© ISO 2012

All rights reserved. Unless otherwise specified, no part of this publication may be reproduced or utilized in any form or by any means, electronic or mechanical, including photocopying and microfilm, without permission in writing from either ISO at the address below or ISO's member body in the country of the requester.

ISO copyright office  
Case postale 56 • CH-1211 Geneva 20  
Tel. + 41 22 749 01 11  
Fax + 41 22 749 09 47  
E-mail [copyright@iso.org](mailto:copyright@iso.org)  
Web [www.iso.org](http://www.iso.org)

Published in Switzerland

# Contents

Page

<b>Foreword</b> .....	<b>iv</b>
<b>Introduction</b> .....	<b>v</b>
<b>1 Scope</b> .....	<b>1</b>
<b>2 Normative references</b> .....	<b>1</b>
<b>3 Terms and definitions</b> .....	<b>1</b>
<b>4 Abbreviated terms</b> .....	<b>3</b>
<b>5 Calibration tasks</b> .....	<b>3</b>
5.1 Principle and overview.....	3
5.2 Types of calibration tasks.....	4
5.3 Critical Tracking Task (CTT).....	4
5.4 Surrogate Reference Task (SURT).....	7
<b>6 Calibration criterion</b> .....	<b>10</b>
6.1 Calibration criterion procedure.....	10
6.2 General calibration consideration.....	11
<b>Annex A (informative) Calibration task setup details</b> .....	<b>12</b>
<b>Annex B (informative) Multi-lab reference data for LCT</b> .....	<b>14</b>
<b>Bibliography</b> .....	<b>16</b>

## Foreword

ISO (the International Organization for Standardization) is a worldwide federation of national standards bodies (ISO member bodies). The work of preparing International Standards is normally carried out through ISO technical committees. Each member body interested in a subject for which a technical committee has been established has the right to be represented on that committee. International organizations, governmental and non-governmental, in liaison with ISO, also take part in the work. ISO collaborates closely with the International Electrotechnical Commission (IEC) on all matters of electrotechnical standardization.

International Standards are drafted in accordance with the rules given in the ISO/IEC Directives, Part 2.

The main task of technical committees is to prepare International Standards. Draft International Standards adopted by the technical committees are circulated to the member bodies for voting. Publication as an International Standard requires approval by at least 75 % of the member bodies casting a vote.

In other circumstances, particularly when there is an urgent market requirement for such documents, a technical committee may decide to publish other types of normative document:

- an ISO Publicly Available Specification (ISO/PAS) represents an agreement between technical experts in an ISO working group and is accepted for publication if it is approved by more than 50 % of the members of the parent committee casting a vote;
- an ISO Technical Specification (ISO/TS) represents an agreement between the members of a technical committee and is accepted for publication if it is approved by 2/3 of the members of the committee casting a vote.

An ISO/PAS or ISO/TS is reviewed after three years in order to decide whether it will be confirmed for a further three years, revised to become an International Standard, or withdrawn. If the ISO/PAS or ISO/TS is confirmed, it is reviewed again after a further three years, at which time it must either be transformed into an International Standard or be withdrawn.

Attention is drawn to the possibility that some of the elements of this document may be the subject of patent rights. ISO shall not be held responsible for identifying any or all such patent rights.

ISO/TS 14198 was prepared by Technical Committee ISO/TC 22, *Road vehicles*, Subcommittee SC 13, *Ergonomics applicable to road vehicles*.

## Introduction

The number of standardized methods to assess driver attentional demand due to the use of in-vehicle information and communication devices is continuing to increase. In applying these methodologies, it is important to understand and document variability in participants' performance of standard calibration tasks and procedures across laboratories and/or time.

A suitable calibration task should have the following attributes:

- It should be robust against the variations in cultural background of participants.
- Properly applied, the task should give repeatable quantitative results. It should be sensitive to inappropriate variations in participants, equipment, location, experimenter and instruction.
- It should use durable and readily available equipment for conducting the task
- It should apply to the driver population and be usable in a driving-like context.

A standardized calibration task can be used to produce a range of statistically stable, repeatable and comparable secondary task demands for a participant in an experimental setting. This setting can be used to assess the effect on driving performance of the attentional demand due to driver interaction with an information, entertainment, and control or communication system while a vehicle is in motion.

Different calibration tasks are specified in this Technical Specification to cover calibration manual and visual aspects of various secondary task characteristics.

# Road vehicles — Ergonomic aspects of transport information and control systems — Calibration tasks for methods which assess driver demand due to the use of in-vehicle systems

## 1 Scope

This Technical Specification provides procedures that can be used as a secondary task in a dual task setting to determine whether that evaluation setting is standardized and valid for purposes of assessing driver attentional demand due to the use of an in-vehicle system. This Technical Specification does not define calibration procedures for other evaluation activities that a laboratory might undertake.

This Technical Specification provides advice on the selection of an appropriate candidate calibration task, given an attentional demand evaluation procedure that uses primary driving-like task settings and procedures which are defined outside of this Technical Specification.

The description of a calibration task includes its application, experimental set-up, data collection, and procedures for analysis of results.

The purpose of this Technical Specification is not to define a reference criterion as to whether a given secondary task is suitable for use while driving. Although specific settings of parameters of a calibration task might be used to realize such a predefined pass/fail criterion, this Technical Specification does not provide such a criterion for a given level of attentional demand.

## 2 Normative references

The following referenced documents are indispensable for the application of this document. For dated references, only the edition cited applies. For undated references, the latest edition of the referenced document (including any amendments) applies.

ISO 15008, *Road vehicles — Ergonomic aspects of transport information and control systems — Specifications and test procedures for in-vehicle visual presentation*

ISO 26022, *Road vehicles — Ergonomic aspects of transport information and control systems — Simulated lane change test to assess in-vehicle secondary task demand*

## 3 Terms and definitions

For the purposes of this document, the following terms and definitions apply.

### 3.1

#### **calibration task**

type of reference task used for the purpose of comparing different tests or test results between sites, or over time at a given site

### 3.2

#### **criterion**

threshold or value of a variable to be met

### 3.3

#### **demand**

total visual, auditory, cognitive, or physical resources required of the driver to accomplish the primary driving task and interact with a Transport Information and Control System (TICS) in a dual task setting



**3.4  
dual task**

two tasks concurrently performed, typically the primary driving task plus the secondary task

**3.5  
environment**

physical surroundings in which data are captured and collected, consequently, the level of control over the independent variables in a study

EXAMPLE Laboratory, simulator, test track, real road.

**3.6  
evaluation**

procedure in which the effect of a Transport Information and Control System (TICS) or other device is assessed

NOTE 1 It may be undertaken retrospectively after the TICS has been in use for a considerable time as a product.

NOTE 2 The results of the evaluation will depend on the HMI, but also on the equipment reliability and subsequent behavioural changes which may affect driving performance.

**3.7  
method**

high-level approach to an assessment, based on theory and principles, which implies an underlying rationale in the choice of assessment techniques

EXAMPLE Behaviour analysis, workload assessment, and analysis of psycho physiological responses.

**3.8  
metric**

quantitative measure of driver behaviour independent of the tool used to measure it

EXAMPLE Eye glance duration and vehicle speed.

**3.9  
performance**

result of skill application demonstrated by a participant in performing a driving task or Transport Information and Control System (TICS) related task

**3.10  
primary driving-like task**

primary task in a dual task setting that simulates or approximates a primary driving task

NOTE The Lane Change Task in ISO 26022 is one example.

**3.11  
primary driving task**

activities that the driver must undertake while driving including navigating, path following, manoeuvring, avoiding obstacles, and controlling speed; and which a participant may perform through the duration of a test (simulated substitute for driving)

**3.12  
secondary task**

non-driving related additional task

NOTE A calibration task for the purpose of this Technical Specification.

**3.13  
secondary task demand**

sum of visual, auditory, cognitive, motor, and speech resource demands required by a non-driving related task

### 3.14

#### **system paced secondary task**

activity in which the change from the current to the next state in the interaction between user and system is initiated by the system

NOTE The pace can be fixed or variable.

### 3.15

#### **target bar**

moving line on the critical tracking task display which indicates the task error

### 3.16

#### **task**

process of achieving a specific and measurable goal using a prescribed method

### 3.17

#### **user paced secondary task**

activity in which the change from the current to the next state in the interaction between user and system is initiated by the user

## 4 Abbreviated terms

CI	Confidence Interval
CTT	Critical Tracking Task
LCT	Lane Change Test
MDEV	Mean Deviation (According to ISO 26022)
SURT	Surrogate Reference Task
TICS	Transport Information and Control System (A list of TICS fundamental services has been defined by ISO/TC204/WG1)

## 5 Calibration tasks

### 5.1 Principle and overview

For calibration purposes, a standardized calibration task shall be used as a secondary task in a dual task setting in combination with a method to assess attentional demand due to the use of an in-vehicle system. The dual task setting shall include a primary driving-like task (primary task) and the secondary calibration task.

Examples for driving-like dual task settings may include the operation of a TICS secondary task in the Lane Change Test or in a driving simulator environment.

The calibration shall be performed in a setting that is intended for the assessment of secondary tasks and follow the training and experimental procedures of that method for assessing attentional demand.

To date, development of the calibration tasks and associated procedures have used the ISO 26022, Lane Change Test (LCT) to represent the primary task. While the calibration tasks described herein are intended to be applicable to other primary driving-like task implementations and dual task settings, care must be taken to ensure that the conditions are sufficiently similar to those of ISO 26022 considering equipment and instructions to ensure a valid application of this specification and its procedures.

## 5.2 Types of calibration tasks

There are various possibilities to realize a calibration task. In the following subclauses, two example alternatives are specified in detail. These alternatives include a system-paced secondary task (critical tracking task) as well as a user-paced secondary task (surrogate reference task). Both alternatives represent visual-manual tasks that can be used in a dual task setting and are recommended as calibration tasks.

## 5.3 Critical Tracking Task (CTT)

### 5.3.1 Description

The CTT is a visual-manual task, which requires continuous control activity by the participant.

The participant controls the position of a vertically moving target bar with respect to a fiducial line (centreline) within a target area by manipulating up and down arrow keys. The arrow key control gives discrete commands to the target bar which moves it up and down. The up key moves the target bar up, and the down key moves it down.

The dynamics of the motion of the target bar are a first order instability. If the participant does nothing, the target bar moves (divergently) towards the edge of the display. The participant then has to make suitable corrective arrow key inputs to bring the target bar back towards the centre (the red dashed line in Figure 2).

A control system block diagram of the CTT is shown in Figure 1.

### 5.3.2 Operation of the CTT

When the program is first started, the screen will look like Figure 2. Nothing will happen initially. The centreline is displayed as a red dashed horizontal line in the centre of the display. The target bar is displayed as a black line. The target bar will start to move away from the centreline showing an increasing error. Two short blue reference lines are shown above and below the centre to subdivide the screen for better orientation. The instruction to the participant is to control the position of the target bar with the arrow keys (arrow up key and arrow down key) and keep it as close to the centreline as possible so as to minimize the errors.

### 5.3.3 Setup for CTT

The setup consists of a 19 inch (483 mm) screen with SVGA resolution plus keyboard. The subtended vision angle (width) of the display area relative to participant's eyes shall be  $13\pm 1$  degrees horizontally. The width to height ratio of display area shall be 4:3. The centre of the secondary display shall be positioned  $28\pm 2$  degrees horizontally (right or left depending on the intended display position in the vehicle, LHD or RHD) and  $20\pm 2$  degrees vertically from participant's straight ahead line of sight. For further details see Annex A.

To control the target bar movement, the arrow key of a standard PC keyboard (or an equivalent arrangement of keys, for example Figure 4) shall be used. Participants are allowed to place the keyboard in a comfortable position on the same side of the steering wheel as the CTT display on a table or console aside but not connected to their body.

### 5.3.4 Test conditions for CTT

The test in the dual task setting shall include one specified level of lambda, 0.5, the CTT easy condition. The lambda level has to be set prior to each run and kept constant during the run. In each run the primary task and the CTT task are to be performed for at least 2 min.

### 5.3.5 Participants for CTT

The CTT as a calibration task shall be performed in a dual task setting by at least 16 [ $n = 16$ ] participants who are licensed drivers. Participants should be familiar with the primary task as well as operation of the CTT. The level of participant familiarity shall be documented in the protocol. In the case of calibration using an LCT setting it is recommended to select the participants according to the ISO 26022 LCT standard, and following the sample description regarding age, gender and familiarity with primary and secondary task in Bengler, K., Mattes, S., Hamm, O., Hensel, M., 2010 [1]. Typically, this was an average age of 32 to 45, gender balanced, and instructed and practiced in both the primary and secondary tasks.

### 5.3.6 Participant instruction of CTT

The following verbal/written instructions for CTT shall be given to the participant:

“A horizontal black target bar is displayed on the secondary task screen. There is also a red dashed horizontal line in the centre of the screen. When the task is started, the black target bar will tend to move away from the red centreline. The motion of the black target bar can be controlled by the arrow-up- and arrow-down keys in order to bring the target bar back to the centre. These keys give discrete commands to the target. (The down arrow key moves the target bar down; the up arrow key moves the target bar up.) The goal is to control the motion of the black target bar to keep it as close as possible to the red dashed centre line.”

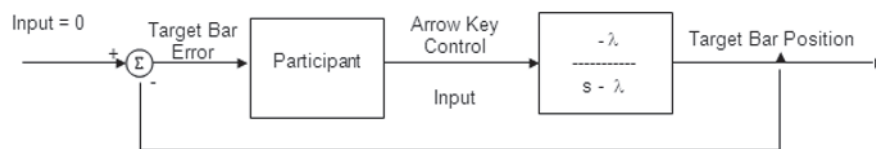

#### Key

- $\lambda$  level of instability or rate of divergence (adjustable)
- $s$  Laplace transform variable

**Figure 1 — Control system block diagram of the CTT**

The lambda level is set to a fixed value at the beginning of a run and defines the secondary task difficulty.

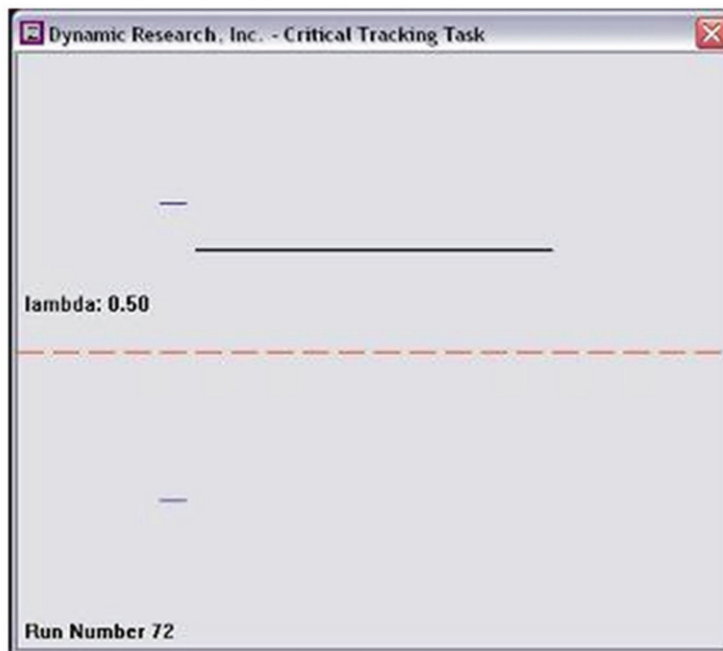

**Key**

- 1 target bar
- 2 centreline

**Figure 2 — Typical screen of the CTT with target bar above the centreline**

If the participant does nothing, the target bar moves towards the edge of the display. The further the black target bar is away from the centre line, the faster it will move, so a larger (longer duration) input is needed, to bring it back to the centreline.

The difficulty of controlling the black target bar can vary with the size of the error. The participant will need to work quickly and correctly in order to keep the target bar near the centreline.

### 5.3.7 Practice trials

Participants shall practice the CTT secondary task alone at lambda levels of 0,5 and 1,0. Before proceeding to the dual task conditions, participants shall be able to perform the CTT alone at a level of lambda = 1,0 for one minute successfully (i.e. without the target bar hitting the upper or lower limit of the display). Only the lambda value of 0,5 is used in the dual task trials.

Primary task and dual task practice trials shall be conducted as prescribed in the corresponding standard or other procedures.

### 5.3.8 Test metrics

The primary task measures shall be those prescribed for the primary task. If the Lane Change Test is used, these are in ISO 26022.

Participants' performance in the CTT is measured using:

- CTT root mean square deviation of the target bar from the centreline in pixels.
- CTT percentage of time with target bar at the upper or lower limit.

## 5.4 Surrogate Reference Task (SURT)

### 5.4.1 Description

The Surrogate Reference Task (SURT) is both visually and manually demanding. The level of demand can be varied.

The SURT is a visual search paradigm. In a typical visual search paradigm, participants are asked to report whether or not a pre-specified target is embedded in a multi-item display, usually comprised of an array of alphanumeric symbols, forms, colours or words. The non-target items are called distractors. To vary the time the participant will need to identify the target and to answer (reaction time), the similarity between target and distractors can be manipulated. The more similar the distractors are to the target the more time is typically needed to identify the target. Unless these distractors have no unique feature distinguishing them from the target (feature with a visual “pop out” character), the number of distractors can also increase the time participants will need for search (Treisman and Gelade, 1980). An example for the task is shown in Figure 3.

For the SURT calibration task the pre-specified target is always present and the participants have to locate the target among more or less visually similar distractors (visual search is visually demanding). The task for the participants is to locate the target and to manually confirm its location (manually demanding). The stimuli for targets and distractors are circles. Only the diameter of the circles distinguishes between target and distractors, while the diameter of the target remains constant. The thickness of the circle shall be equal for both target and distractors.

For the participant to be able to indicate the position of the target, the display is divided into evenly distributed vertically arranged rectangular areas. During search none of these areas is marked and no highlight is visible. Once the participant visually locates the target, the participant should press the left or right key (indicated by graphics on the keys) depending on the position of the target on the display, and the highlight (as in Figure 3) will appear immediately to the left or right of the centreline of the display. Consecutive presses on the keys moves the highlight to the left or right. The participant uses the keys to move the highlight until s/he has positioned the highlight over the target. Finally s/he has to confirm completion of the task by pressing a third key (confirmation key).

The response time is defined as the time from stimulus onset to the keypress of the confirmation key. The task is participant paced, i.e. there is no time out. If the target is within the highlighted area when the confirmation key is pressed, the answer is recorded as correct, otherwise as incorrect. Response times are measured to estimate the participant’s performance with different difficulty levels of the calibration task, and to confirm increasing calibration task difficulty.

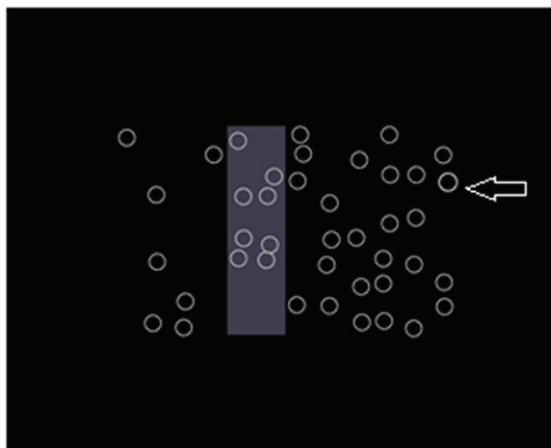

**Figure 3 — Visual display of SURT distractors and target (here the target is the right circle in the upper area marked by the arrow). The visual display of SURT in operation does not include the marking arrow**

#### 5.4.2 Setup for SURT

Calibration task display set-up should be as follows, in order to make all values consistent between tests or sites:

- Vision angle of the display area from participant's eyes shall be  $13 \pm 1$  degrees horizontally.
- Width to height ratio of display area: 4:3.
- Centre of display shall be positioned  $28 \pm 2$  degrees horizontally (right or left depending expected position of system to be tested) and  $20 \pm 2$  degrees vertically from participant's straight ahead line of sight.
- Line thickness of target and distractors: 0,07 degrees corresponding to approximately 1 mm when viewed at a distance of 800 mm.
- Target size: 0,7 degrees corresponding to approx. 10 mm when viewed at a distance of 800 mm.
- Background colour: black (RGB-Values: 0, 0, 0).
- Target and distractor colours: light grey (RGB-Value: 192, 192, 192).
- Highlighting colour: medium grey (RGB-Value: 160, 160, 160).
- Minimum contrast (light/dark), target and distractors to background: 8:1 (ISO 15008).

An example setup is shown in Annex A.

Once the target circle is located, the manual answer is given using the arrow key of a standard PC keyboard or an equivalent keypad. The arrangement of the keys shown in Figure 4 may be used. The left/right keys move the shaded area over the target circle. Either up/down key can be used to enter the answer. Participants can place the keyboard at their own comfort on the same side of the steering wheel as the Calibration task display. Alternatively, the keyboard may be part of the Calibration task display unit (lap-top computer).

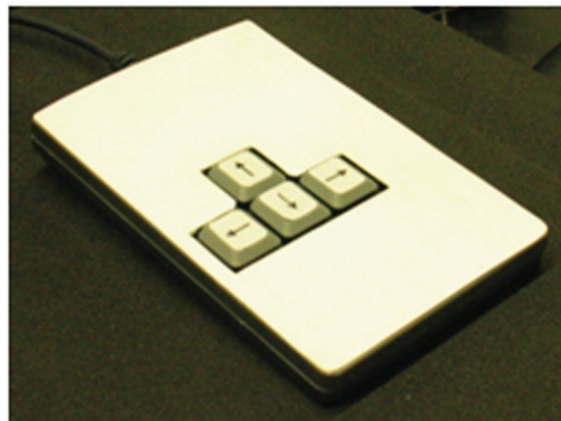

**Figure 4 — Example of key-pad to move the highlight and confirm target location result**

The background colour of the Calibration task display is black (RGB-Values: 0, 0, 0). Each display consists of one target and 50 distractors. Targets and distractors are randomly distributed over the whole display. The items should not intersect with each other.

To control the visual demand of the Calibration task it is possible to manipulate the size of the distractors (e.g. diameter). Distractor size closer to target size will result in higher visual demand. The more the distractor size differs from the target size the less visual demanding the Calibration task will be.

### 5.4.3 Test conditions for SURT

The test shall include one level of difficulty. The test duration should be approximately 2 min.

Figure 3 shows an example for the SURT hard condition to be used. Using a display distance of 78,5 cm, – the target size is 61 arcmin (14 mm); the distractor 53 arcmin (12 mm).

### 5.4.4 Participants for SURT

The SURT as a calibration task shall be performed in a dual task setting by at least 16 participants [ $n = 16$ ]. Participants shall be familiar with the primary task as well as the SURT. The level of participants' familiarity with the primary task and the SURT shall be documented in the protocol. For example, state that the participant performed this secondary task previously in a dual task condition. In the case of calibration using the LCT procedure it is recommended to select the participants following the protocols in ISO 26022 and the sample description in Bengler, K., Mattes, S., Hamm, O., Hensel, M., 2010. For LCT being the primary driving like task the number of  $n = 16$  participants is based on the experience of Bengler et al. 2010 [10].

### 5.4.5 Participant instructions for SURT

All participants should be instructed the same way as follows:

An array of circles is displayed on the secondary task screen which is down and to the right of the driving simulation scene. One of these circles is bigger than the other ones. The position of this circle is randomly varying, but the positioning should not influence the difficulty to detect the difference. The participant task is to find the bigger circle and decide whether it is located in the left or in the right part of the screen. Accordingly, the participant has to press the left or right arrow key. Sometimes the decision is just left or right to highlight the bigger circle and sometimes the participant has to press the left or right key several times to highlight the bigger circle depending on the width of the highlighted area. To confirm the decision the participant has to press the [arrow-up/confirmation] key. The next trial starts automatically without any delay.

Instructions on dual task attention allocation should be those for the dual task procedure being used. In the case of the LCT procedure as one realization of a primary driving task, those instructions are given in 3.6 and Annex A of ISO 26022.

### 5.4.6 Practice trials

Primary task and dual task practice trials shall be conducted as prescribed in the primary task settings and procedures.

Participants shall be able to perform the so called “hard” level of the SURT under a single task condition before going to the dual task condition.

### 5.4.7 Test metrics

The primary task performance measures shall be those prescribed for the primary task. If the Lane Change Test is used, these are in ISO 26022.

Participants' performance in the SURT is measured using:

- Percentage of correctly solved screens;
- Mean response time per SURT screen in seconds.



## 6 Calibration criterion

### 6.1 Calibration criterion procedure

The calibration assessment shall be performed using a primary driving like task performance measure, and confidence intervals for the respective metric. The performance values in the primary driving like task and the secondary tasks of the laboratory under calibration shall be compared to a confidence interval based on the data provided in Annex B of this Technical Specification as a reference zone of indifference.

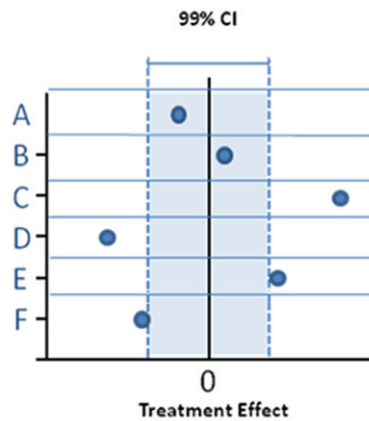

**Figure 5 — Possible outcomes for six different laboratory values (A to F) and zone of indifference calibration data**

Figure 5 illustrates how the performance values of a laboratory under calibration might correspond to a calibration data set.

A laboratory setting shall be called calibrated if the values of the test sample are within a 99 % CI of the calibration data set for their corresponding values.

For the purpose of calibration, case A or B is desired, whereas cases C, D are clear indications of an absence of equivalence. Cases E and F are acceptable for calibration, but it is strongly recommended to check the data set and laboratory situation.

If the E or F case occurs, it shall be checked using the primary driving like task performance measure in the baseline single task condition, and the SURT hard and CTT ( $\lambda$  level = 0,5) dual task conditions. At the same time, the secondary task performance measure should be at least at a minimum level for the CTT and for the SURT (see Annex B values from multi-lab data set).

The level of calibration shall be checked in three conditions following a staged approach. It is recommended to check the value the baseline performance of each subject in the primary driving like task in advance of the further calibration analysis. The following conditions are:

- Compare the primary driving like task baseline performance mean value of the sample to the 99 % CI of the corresponding reference data set (given for the LCT in Table B.1 in Annex B).
- Compare the primary driving like task performance mean value in the CTT dual task condition to the 99 % CI of the multi-lab data set, and compare the CTT performances (given for the LCT in Tables B.1 and B.3 in Annex B).
- Compare the primary driving like task performance mean value in the SURT dual task condition to the 99 % CI of the multi-lab data set, and compare the SURT performances (given for the LCT in Tables B.1 and B.2 in Annex B).

A laboratory shall be called

- (I) Fully calibrated, if in conditions 1, 2 and 3 the laboratory primary driving like task performance in the baseline, CTT, and SURT conditions lie within the corresponding confidence intervals.
- (II) Partially calibrated, if in condition 1 and 2 or 1 and 3 the laboratory primary driving like task performance in the baseline, CTT and/or SURT condition lies within the corresponding confidence intervals.
- (III) Not calibrated, if in condition 1 only the laboratory primary driving like task performance in the baseline condition lies within the corresponding confidence interval.

For a more sophisticated description of methods for equivalence testing refer to: Wellek, S. (2003) [11].

## 6.2 General calibration consideration

In general the following conditions shall be satisfied as part of the calibration procedure:

- Primary task performance baseline is better than primary task performance in either the dual task SURT or dual task CTT condition.
- Primary task performance in a dual task CTT\_easy condition is better than primary task performance in a dual task SURT\_hard condition.

In the event that the calibration criteria and considerations are not satisfied, the experimenter should check that data analysis followed the prescribed procedures in this Technical Specification and the prescription of the primary driving like task. Further, all equipment and setup should be checked for consistency with the prescriptions in this Technical Specification. For example, different results can be obtained if an experiment is conducted on a desktop computer or using a more extensive driving simulator (Bruyas et al. 2008 [2]). This may be due to differences in the simulated vehicle dynamics, the steering feel characteristics, the size and quality of the primary task roadway image, etc.

A general linear shift of mean values above or below the levels shown in the Annex B reference tables for the primary driving like task performance can be due to a selection of participants as weak or strong in task performance. There is evidence in the data of Bengler et al. 2010 [1] that age and experience with the primary driving like task and/or with the secondary task can be moderating factors.

Especially with regard to II and III, it is recommended to check SURT or CTT equipment, and instructions on dual task conditions.

The calibration procedure may be repeated after a suspected source for the lack of calibration has been removed.

Despite using the specified procedures and due scientific care, it may be the case that a laboratory is still unable to achieve “calibrated” status in accordance with this Technical Specification. This may not be the result of a scientific or technical deficiency on the part of the laboratory. Instead, it may reflect differences in the participants’ understanding and interpretation of instructions and procedures on the part of the participants, or the effect of other local customs regarding driver behaviour or attentional factors in general.

## Annex A (informative)

### Calibration task setup details

A typical experimental setup involves a monitor for the primary task, and an 8,4 inch (213 mm) diagonal screen monitor for the Calibration task display. The participant should sit directly in front of the primary task monitor. In the example of Figure A.1 an LCT primary driving task is presented on a monitor at a distance of 900 mm (viewing angles of 0 degrees horizontally and 0 degrees vertically to centre of monitor). This results in an angle of vision of approximately 20 degrees horizontally for the primary task (LCT) scene on a 16 inch (406 mm) diagonal monitor.

The following values for the Calibration task set up will then apply:

- Calibration task display position relative to LCT monitor: 240 mm downward, 350 mm rightward, 240 mm forward (for a left hand drive country).
- Resulting distance to Calibration task display: 785 mm.
- Resulting viewing angle to Calibration task display: 28 deg horizontally (rightwards) and 20 deg vertically (downwards).
- Resulting angle of vision: 12,4 deg horizontally (with an 8,4 inch monitor).

In countries where a right-hand drive vehicle is used, the Calibration task screen should be placed left-downward to the visual scene of an LCT-Simulation.

The experimental setup is shown in Figure A.1 for a left-hand drive country. A 16 inch monitor can be used for the visual scene of an LCT-simulation primary task. A steering wheel is used for the LCT-simulation. The display for the Calibration task is on the lower right in the front view. A photograph is shown in Figure A.2.

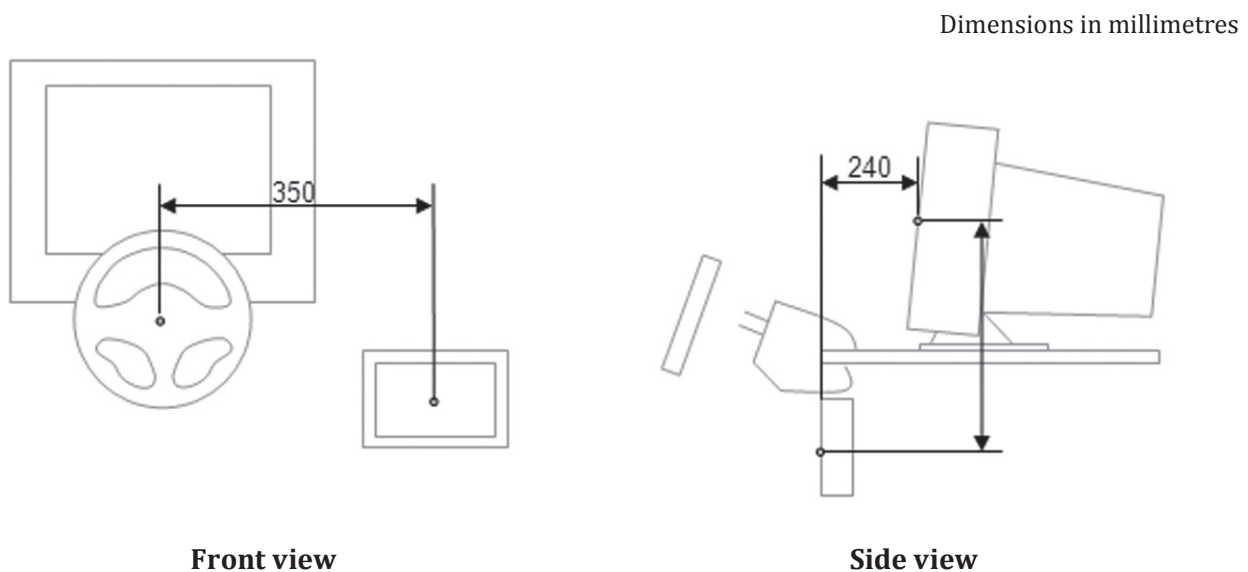

Figure A.1 — Example setup for primary task (LCT example) and secondary task display



**Figure A.2 — Setup for primary task (LCT example) and secondary task (CTT example)**

## Annex B (informative)

### Multi-lab reference data for LCT

The following tables give an overview of comparison values for the assessment of calibration criterion (see Clause 6). The values are calculated on the basis of the Multi-Laboratory Calibration Study (Bengler, K., Mattes, S., Hamm, O., Hensel, M., 2010 [1]). This study used the Lane Change Test as the primary task.

If the LCT is being used as the primary driving like task the level of calibration shall be checked in three conditions following a staged approach. If the LCT is used as the primary task it is recommended to check the basic  $MDEV_{baseline}$  value of each subject in advance of the further calibration analysis. The basic  $MDEV_{baseline}$  value should not exceed a level of 1.2 in accordance with the ISO 26022 training procedure. The conditions are:

- Compare LCT adaptive  $MDEV_{baseline}$  mean value to the 99 % CI of the multi-lab data-set (given by Table B.1)
- Compare LCT adaptive  $MDEV_{CTT}$  to the 99 % CI of the multi-lab data-set, and compare CTT performance (given by Tables B.1 and B.3)
- Compare LCT adaptive  $MDEV_{SURT}$  to the 99 % CI of the multi-lab data-set, and compare SURT performance (given by Tables B.1 and B.2)

With LCT as the primary task, a laboratory shall be called

- (I) Fully calibrated, if in conditions 1, 2 and 3 the laboratory adaptive  $MDEV_{baseline}$ ,  $MDEV_{SURT}$  and  $MDEV_{CTT}$  values lie within the corresponding confidence intervals.
- (II) Partially calibrated, if in conditions 1 and 2 or 1 and 3 the laboratory adaptive  $MDEV_{baseline}$  and  $MDEV_{SURT}$  and/or  $MDEV_{CTT}$  lie within the corresponding confidence intervals.
- (III) Not calibrated, if in condition 1 only the laboratory primary task adaptive  $MDEV_{baseline}$  lies within the corresponding confidence intervals.

**Table B.1 — Adaptive MDEV values for LCT: Baseline and with CTT and SURT secondary tasks**

Tasks	Number of labs	Mean	StdDev	Stder	99 % -CI Lower	99 % -CI Upper
Baseline	7	0,37	0,03	0,01	0,32	0,42
CTT easy	6	0,60	0,04	0,01	0,54	0,66
SURT hard	6	0,73	0,05	0,02	0,64	0,82

**Table B.2 — Secondary task performance SuRT response time in the hard condition**

	Number of labs	Mean [sec]	StdDev	Stder	99 % -CI Lower	99 % -CI Upper
Response Time	6	7,29	1,22	0,50	5,28	9,30

**Table B.3 — Secondary task performance CTT root mean square deviation in the  $\lambda = 0,5$  condition**

	<b>Number of labs</b>	<b>Mean</b>	<b>StdDev</b>	<b>Stder</b>	<b>99 % -CI Lower</b>	<b>99 % -CI Upper</b>
Deviation	6	7,56	2,19	0,89	3,96	11,16

Some feedback from the Interlab experiment could be helpful in the event that a laboratory appears not calibrated. It has been shown that:

Sometimes wrong calculations can give wrong results:

- If LCT is used as the primary task, the experimenter has to ensure that basic mdev values follow the requirement not to exceed the criterion value of 1,2 as formulated in ISO 26022.
- Drivers with too much experience in either the primary task or a secondary task may cause a sample to be outside the 99 % CI (too low values).
- A more complex (incorrect) version of a calibration task could lead to poorer driver performance (too high values).

The mean age of the sample participants could also influence the data; older participants may obtain poorer results (higher values).

## Bibliography

- [1] BENGLER K., MATTES S., HAMM O., HENSEL M. *Lane Change Test: Preliminary Results of a Multi-Laboratory Calibration Study. Performance Metrics for Assessing Driver Distraction: The Quest for Improved Road Safety.* SAE International, Warrendale, PA, 2010
- [2] BRUYAS M.P., BRUSQUE C., TATTEGRAIN V., AURIAULT A., AILLERIE I., DURAZ M. (2008). Consistency and sensitivity of lane change test according to driving simulator characteristics, IET Intelligent Transport Systems journal, 2(4), 306-314
- [3] DAMOS D.L., BITTNER A.C., KENNEDY R.S., HARBESON M.M. (1981). Effects of Extended Practice on Dual-Task Tracking Performance. *Human Factors: The Journal of the Human Factors and Ergonomics Society* October, 23(5), 627-631
- [4] HARBLUK J.L., BURNS P.C., LOCHNER M., TRBOVICH P.L. (2007). Using the lane-change test (LCT) to assess distraction: Tests of visual-manual and speech-based operation of navigation system interfaces. 4th International Driving Symposium on Human Factors in Driver Assessment, Training, and Vehicle Design. Stevenson, Washington: July 2007
- [5] HARBLUK J.L., MITROI J.S., BURNS P.C. (2009). Three navigation systems with three tasks: Using the lane change test (LCT) to assess distraction demand. Proceedings of the 5th International Driving Symposium on Human Factors in Driver Assessment, Training, and Vehicle Design. Big Sky, Montana, June 2009
- [6] HUNG J.H.Wang, S./J., Lawrence, J., O'Neil, R.T. (2001). Some Fundamental Issues With Non-Inferiority Testing In Active Controlled. Proceedings of the Annual Meeting of the American Statistical Association, August 5-9, 2001
- [7] JAGACINSKI R.J., MILLER D.P., GILSON R.D. A comparison of kinesthetic-tactual and visual displays via a critical tracking task. *Hum. Factors.* 1979, **21** (1) pp. 79-86
- [8] JEX H.R., McDONNELL J.D., PHATAK A.V. A "Critical" Tracking Task for Manual Control Research. *IEEE Transactions on Human Factors in Electronics.* 1966, **7** (4) pp. 138-145
- [9] KLEIN R.H., & JEX H.R. Effects of alcohol on a Critical Tracking Task. *J. Stud. Alcohol.* 1975, **36** (1) pp. 11-20
- [10] TREISMAN A., & GELADE G. A feature integration theory of attention. *Cognit. Psychol.* 1980, **12** pp. 97-136
- [11] WELLEK S. *Testing statistical hypotheses of equivalence.* CRC Press, Boca Raton, 2003







# British Standards Institution (BSI)

BSI is the independent national body responsible for preparing British Standards and other standards-related publications, information and services. It presents the UK view on standards in Europe and at the international level.

BSI is incorporated by Royal Charter. British Standards and other standardisation products are published by BSI Standards Limited.

## Revisions

British Standards and PASs are periodically updated by amendment or revision. Users of British Standards and PASs should make sure that they possess the latest amendments or editions.

It is the constant aim of BSI to improve the quality of our products and services. We would be grateful if anyone finding an inaccuracy or ambiguity while using British Standards would inform the Secretary of the technical committee responsible, the identity of which can be found on the inside front cover. Similar for PASs, please notify BSI Customer Services.

**Tel: +44 (0)20 8996 9001 Fax: +44 (0)20 8996 7001**

BSI offers BSI Subscribing Members an individual updating service called PLUS which ensures that subscribers automatically receive the latest editions of British Standards and PASs.

**Tel: +44 (0)20 8996 7669 Fax: +44 (0)20 8996 7001**

**Email: [plus@bsigroup.com](mailto:plus@bsigroup.com)**

## Buying standards

You may buy PDF and hard copy versions of standards directly using a credit card from the BSI Shop on the website [www.bsigroup.com/shop](http://www.bsigroup.com/shop). In addition all orders for BSI, international and foreign standards publications can be addressed to BSI Customer Services.

**Tel: +44 (0)20 8996 9001 Fax: +44 (0)20 8996 7001**

**Email: [orders@bsigroup.com](mailto:orders@bsigroup.com)**

In response to orders for international standards, BSI will supply the British Standard implementation of the relevant international standard, unless otherwise requested.

## Information on standards

BSI provides a wide range of information on national, European and international standards through its Knowledge Centre.

**Tel: +44 (0)20 8996 7004 Fax: +44 (0)20 8996 7005**

**Email: [knowledgecentre@bsigroup.com](mailto:knowledgecentre@bsigroup.com)**

BSI Subscribing Members are kept up to date with standards developments and receive substantial discounts on the purchase price of standards. For details of these and other benefits contact Membership Administration.

**Tel: +44 (0)20 8996 7002 Fax: +44 (0)20 8996 7001**

**Email: [membership@bsigroup.com](mailto:membership@bsigroup.com)**

Information regarding online access to British Standards and PASs via British Standards Online can be found at [www.bsigroup.com/BSOL](http://www.bsigroup.com/BSOL)

Further information about British Standards is available on the BSI website at [www.bsi-group.com/standards](http://www.bsi-group.com/standards)

## Copyright

All the data, software and documentation set out in all British Standards and other BSI publications are the property of and copyrighted by BSI, or some person or entity that own copyright in the information used (such as the international standardisation bodies) has formally licensed such information to BSI for commercial publication and use. Except as permitted under the Copyright, Designs and Patents Act 1988 no extract may be reproduced, stored in a retrieval system or transmitted in any form or by any means – electronic, photocopying, recording or otherwise – without prior written permission from BSI. This does not preclude the free use, in the course of implementing the standard, of necessary details such as symbols, and size, type or grade designations. If these details are to be used for any other purpose than implementation then the prior written permission of BSI must be obtained. Details and advice can be obtained from the Copyright & Licensing Department.

**Tel: +44 (0)20 8996 7070**

**Email: [copyright@bsigroup.com](mailto:copyright@bsigroup.com)**

## BSI

389 Chiswick High Road London W4 4AL UK

Tel +44 (0)20 8996 9001

Fax +44 (0)20 8996 7001

[www.bsigroup.com/standards](http://www.bsigroup.com/standards)