

PD ISO/TS 13399-60:2014



BSI Standards Publication

Cutting tool data representation and exchange

Part 60: Reference dictionary for connection
systems

bsi.

...making excellence a habit.™

National foreword

This Published Document is the UK implementation of ISO/TS 13399-60:2014. It supersedes DD ISO/TS 13399-60:2007 which is withdrawn.

The UK participation in its preparation was entrusted to Technical Committee MTE/18, Tools tips and inserts for cutting applications.

A list of organizations represented on this committee can be obtained on request to its secretary.

This publication does not purport to include all the necessary provisions of a contract. Users are responsible for its correct application.

© The British Standards Institution 2014. Published by BSI Standards Limited 2014

ISBN 978 0 580 82715 0

ICS 25.100.01; 35.240.50

Compliance with a British Standard cannot confer immunity from legal obligations.

This Published Document was published under the authority of the Standards Policy and Strategy Committee on 28 February 2014.

Amendments issued since publication

Date	Text affected
------	---------------

**TECHNICAL
SPECIFICATION**

**ISO/TS
13399-60**

Second edition
2014-02-15

**Cutting tool data representation and
exchange —**

**Part 60:
Reference dictionary for connection
systems**

*Représentation et échange des données relatives aux outils
coupants —*

Partie 60: Dictionnaire de référence pour les systèmes de connexion



Reference number
ISO/TS 13399-60:2014(E)

© ISO 2014



COPYRIGHT PROTECTED DOCUMENT

© ISO 2014

All rights reserved. Unless otherwise specified, no part of this publication may be reproduced or utilized otherwise in any form or by any means, electronic or mechanical, including photocopying, or posting on the internet or an intranet, without prior written permission. Permission can be requested from either ISO at the address below or ISO's member body in the country of the requester.

ISO copyright office
Case postale 56 • CH-1211 Geneva 20
Tel. + 41 22 749 01 11
Fax + 41 22 749 09 47
E-mail copyright@iso.org
Web www.iso.org

Published in Switzerland

Contents

Page

Foreword	iv
Introduction	vi
1 Scope	1
2 Normative references	2
3 Terms and definitions	2
4 Abbreviated terms	5
5 Representation of the ontology concepts as dictionary entries	5
5.1 General.....	5
5.2 connection interface feature.....	5
6 Properties for connection interface feature	8
6.1 General.....	8
6.2 Definition of the structure of connection interface code.....	9
6.3 Representation of connection interface code.....	12
6.4 Representation of insert interface code.....	15
Annex A (normative) Information object registration	27
Annex B (informative) Classification table	28
Annex C (informative) Class definitions	37
Annex D (informative) Connection interface feature property definitions	87
Annex E (informative) Illustrations of connection systems	92
Bibliography	138

Foreword

ISO (the International Organization for Standardization) is a worldwide federation of national standards bodies (ISO member bodies). The work of preparing International Standards is normally carried out through ISO technical committees. Each member body interested in a subject for which a technical committee has been established has the right to be represented on that committee. International organizations, governmental and non-governmental, in liaison with ISO, also take part in the work. ISO collaborates closely with the International Electrotechnical Commission (IEC) on all matters of electrotechnical standardization.

The procedures used to develop this document and those intended for its further maintenance are described in the ISO/IEC Directives, Part 1. In particular the different approval criteria needed for the different types of ISO documents should be noted. This document was drafted in accordance with the editorial rules of the ISO/IEC Directives, Part 2 (see www.iso.org/directives).

Attention is drawn to the possibility that some of the elements of this document may be the subject of patent rights. ISO shall not be held responsible for identifying any or all such patent rights. Details of any patent rights identified during the development of the document will be in the Introduction and/or on the ISO list of patent declarations received (see www.iso.org/patents).

Any trade name used in this document is information given for the convenience of users and does not constitute an endorsement.

For an explanation on the meaning of ISO specific terms and expressions related to conformity assessment, as well as information about ISO's adherence to the WTO principles in the Technical Barriers to Trade (TBT) see the following URL: Foreword - Supplementary information

The committee responsible for this document is ISO/TC 29, *Small Tools*.

This second edition cancels and replaces the first edition (ISO/TS 13399-60:2007), which has been technically revised. The following are the main changes:

- subclauses for connection interface features have been added in [5.2](#);
- [Clause 6](#) has been revised.

ISO 13399 consists of the following parts, under the general title *Cutting tool data representation and exchange*:

- *Part 1: Overview, fundamental principles and general information model*
- *Part 2: Reference dictionary for cutting items* [Technical Specification]
- *Part 3: Reference dictionary for tool items* [Technical Specification]
- *Part 4: Reference dictionary for adaptive items* [Technical Specification]
- *Part 5: Reference dictionary for assembly items* [Technical Specification]
- *Part 50: Reference dictionary for reference systems and common concepts* [Technical Specification]
- *Part 60: Reference dictionary for connection systems* [Technical Specification]
- *Part 100: Definitions, principles and methods for reference dictionaries* [Technical Specification]
- *Part 150: Usage guidelines* [Technical Specification]
- *Part 301: Concept for the design of 3D models based on properties according to ISO/TS 13399-3: Modelling of thread-cutting taps, thread-forming taps and thread-cutting dies* [Technical Specification]
- *Part 302: Concept for the design of 3D models based on properties according to ISO/TS 13399-3: Modelling of solid drills and countersinking tools* [Technical Specification]

The following parts are under preparation:

- *Part 51: Designation system for customer solution cutting tools*
- *Part 80: Concept for the design of 3D models based on properties according to ISO 13399: Overview and principles [Technical Specification]*
- *Part 201: Concept for the design of 3D models based on properties according to ISO/TS 13399-2: Modelling of regular inserts [Technical Specification]*
- *Part 202: Concept for the design of 3D models based on properties according to ISO/TS 13399-2: Modelling of irregular inserts [Technical Specification]*
- *Part 203: Concept for the design of 3D models based on properties according to ISO/TS 13399-2: Modelling of exchangeable inserts for drilling [Technical Specification]*
- *Part 204: Concept for the design of 3D models based on properties according to ISO/TS 13399-2: Modelling of inserts for reaming [Technical Specification]*
- *Part 303: Concept for the design of 3D models based on properties according to ISO/TS 13399-3: Modelling of end mills with non-indexable cutting edges [Technical Specification]*
- *Part 304: Concept for the design of 3D models based on properties according to ISO/TS 13399-3: Modelling of milling cutters with arbor hole and non-indexable cutting edges [Technical Specification]*
- *Part 307: Concept for the design of 3D models based on properties according to ISO/TS 13399-3: Modelling of end mills for indexable inserts [Technical Specification]*
- *Part 308: Concept for the design of 3D models based on properties according to ISO/TS 13399-3: Modelling of milling cutter with arbor hole for indexable inserts [Technical Specification]*
- *Part 309: Concept for the design of 3D models based on properties according to ISO/TS 13399-3: Tool holders for indexable inserts [Technical Specification]*
- *Part 311: Concept for the design of 3D models based on properties according to ISO/TS 13399-3: Modelling of solid reamers [Technical Specification]*
- *Part 312: Concept for the design of 3D models based on properties according to ISO/TS 13399-3: Modelling of reamers for indexable inserts [Technical Specification]*
- *Part 401: Concept for the design of 3D models based on properties according to ISO/TS 13399-4: Modelling of converting, extending and reducing adaptive items [Technical Specification]*
- *Part 405: Concept for the design of 3D models based on properties according to ISO/TS 13399-4: Modelling of collets [Technical Specification]*

Introduction

This part of ISO 13399 defines the terms, properties, and definitions for connection systems of cutting tools with defined cutting edges. The purpose of this part of ISO 13399 is to provide a reference dictionary to support the use of the general information model in ISO 13399-1.

A cutting tool with defined cutting edges is used on a machine to remove material from a workpiece by a shearing action at the cutting edges of the tool. Cutting tool data that can be described by ISO 13399 (all parts) include, but are not limited to, everything between the workpiece and the machine tool. Information about inserts (e.g. regular and irregular shaped replaceable cutting items), solid tools (e.g. solid drill and endmill), assembled tools (e.g. boring bars, indexable drills, and indexable milling cutters), adaptors (e.g. milling arbor and drilling chuck), components (e.g. shims, screws, and clamps), and their relationships can be represented by ISO 13399 (all parts). Possible assemblies of the components of a cutting tool are illustrated in [Figure 1](#).

The objective of ISO 13399 (all parts) is to provide the means to represent the information that describes cutting tools in a computer-sensible form that is independent from any computer system. The representation will facilitate the processing and exchange of cutting tool data within and between different software systems and computer platforms and support the application of this data in manufacturing planning, cutting operations, and the supply of tools. The nature of this description makes it suitable not only for neutral file exchange, but also as a basis for implementing and sharing product databases and for archiving. The methods used for these representations are those developed by ISO/TC 184/SC 4 for the representation of product data by using standardized information models and reference dictionaries.

An information model is a formal specification of types, ideas, facts, and processes which together describe a portion of interests of the real world and which provides an explicit set of interpretation rules. Information is knowledge of ideas, facts, and/or processes. Data are symbols or functions that represent information for processing purposes. Data are interpreted to extract information by using rules for how that should be done and a dictionary to define the terms that identify the data items. Everyone in a communication process is expected to use the same information model, the same set of explicit rules, and the same dictionary in order to avoid misunderstanding. If an information model and its dictionary are written in a computer-sensible language, then there is the additional benefit that they can be computer processable.

An engineering information model is therefore a specification for data that establishes the meaning of that data in a particular engineering context. A model has to be developed by formal methods to ensure that it meets the needs of the situation that it represents. An engineering information model defines the information objects that represent the concepts in an engineering application, the attributes of the objects, their relationships, and the constraints that add further meaning. An information model is an abstract concept that can be used repeatedly for any example of the real-world situation that it represents. An instance of the model is created when it is populated with the data items and their values that are applicable to a particular example of that situation.

This part of ISO 13399 uses the following International Standards developed by ISO/TC 184/SC 4:

- the EXPRESS language defined in ISO 10303-11 for defining the information model in ISO 13399-1;
- the file format for data exchange derived from the model and defined in ISO 10303-21;
- the data dictionary defined in the ISO 13584 series.

The ISO 13399 series is intended for use by, among others, tool producers and vendors, manufacturers, and developers of manufacturing software. ISO 13399 provides a common structure for exchanging data about cutting tools with defined cutting edges. ISO 13399 is intended to provide for, or improve, several manufacturing activities, including

- the integration and sharing of data for cutting tools and assemblies between different stages for the manufacturing cycle and between different software applications,

- the direct import of data from cutting tool suppliers into a customer's database, and
- the management of cutting tool information from multiple sources and for multiple applications.

Different companies use different business models that determine their need for the communication of information about their products. For example, one cutting tool manufacturer can regrind its customers' tools while another could allow its customers to do the regrinding and provide the information to enable them to do so. Therefore, the two cutting tool manufacturers can have a different set of cutting tool properties to communicate using the information model and dictionaries provided in ISO 13399.

ISO 13399 only defines the information that could be communicated, but does not specify what information shall be communicated.

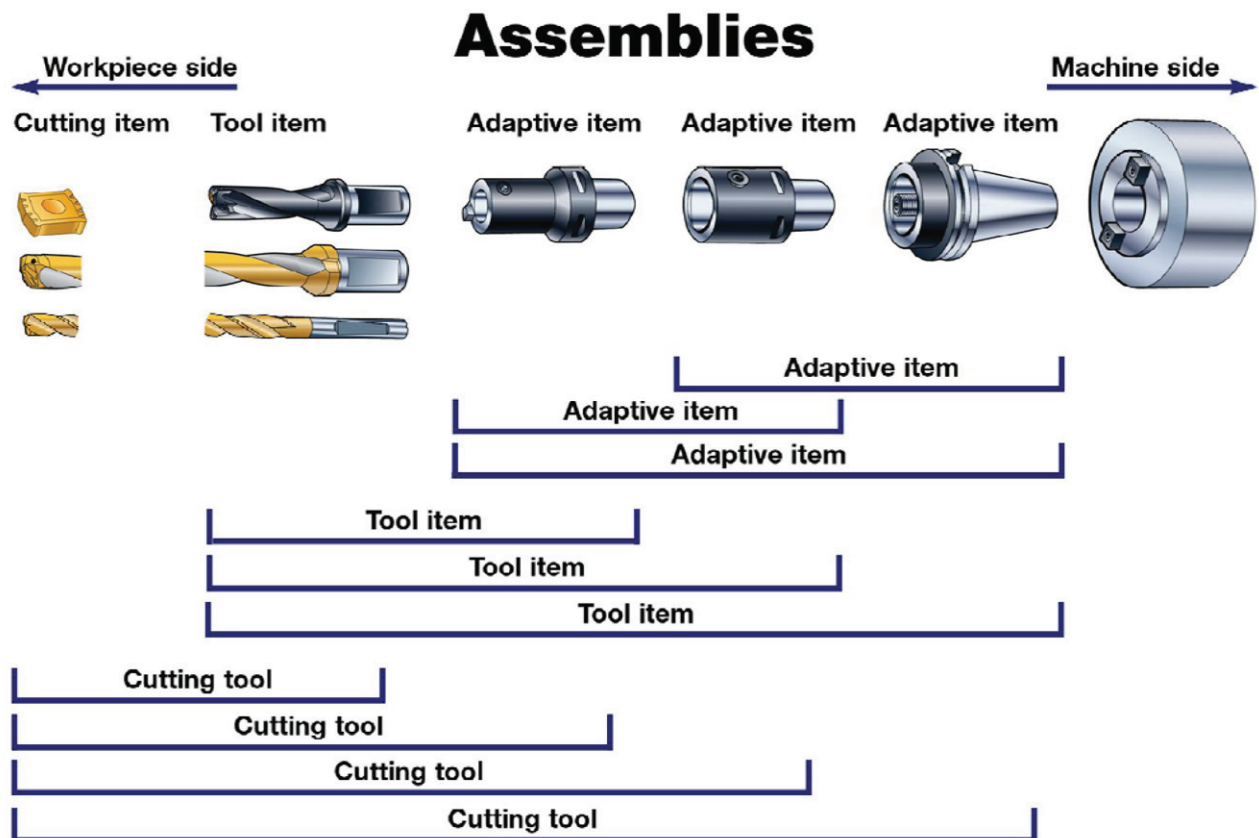

Figure 1 — Example of different types of assemblies of items

Since the content of those dictionaries evolves according to industrial innovations and constant improvement of technology in cutting tools, a Maintenance Agency has been established for the purposes of

- correcting errors in the entries of existing classes and properties,
- adding new properties to existing classes,
- adding new classes and their properties,
- managing the status of those properties and classes, and
- migrating the dictionary to subsequent editions of ISO 13399 (all parts).

The secretariat of this Maintenance Agency has been assigned to:

Union de Normalisation de la Mécanique

F-92038 Paris La Défense CEDEX

France

by the ISO Technical Management Board.

The website of the Maintenance Agency is available at: http://www.unm.fr/main/core.php?pag_id=135

The reference dictionaries are available in the form of EXPRESS files on the website of the Maintenance Agency. These files are considered complementary to this part of ISO 13399; they can be freely downloaded and used for cutting tool data representation and exchange.

The following permission notice and disclaimer shall be included in all copies of this EXPRESS schema ("the Schema"), and derivations of the Schema:

© ISO 2014 – All rights reserved

Permission is hereby granted, free of charge in perpetuity, to any person obtaining a copy of the Schema, to use, copy, modify, merge and distribute free of charge, copies of the Schema for the purposes of developing, implementing, installing and using software based on the Schema, and to permit persons to whom the Schema is furnished to do so, subject to the following conditions:

THE SCHEMA IS PROVIDED "AS IS", WITHOUT WARRANTY OF ANY KIND, EXPRESSED OR IMPLIED, INCLUDING, BUT NOT LIMITED TO, THE WARRANTIES OF MERCHANTABILITY, FITNESS FOR A PARTICULAR PURPOSE AND NON-INFRINGEMENT. IN NO EVENT SHALL ISO, OR ANY OTHER LICENSOR THAT GRANTS THE RIGHT UNDER THE ABOVE PERMISSION TO USE THE SCHEMA, BE LIABLE FOR ANY CLAIM, DAMAGES OR OTHER LIABILITY, WHETHER IN AN ACTION OF CONTRACT, TORT OR OTHERWISE, ARISING FROM, OUT OF OR IN CONNECTION WITH THE SCHEMA OR THE USE OR OTHER DEALINGS IN THE SCHEMA.

In addition, any modified copy of the Schema shall include the following notice:

THIS SCHEMA HAS BEEN MODIFIED FROM THE SCHEMA DEFINED IN ISO 13399, AND SHOULD NOT BE INTERPRETED AS COMPLYING WITH THAT INTERNATIONAL STANDARD.

Cutting tool data representation and exchange —

Part 60: Reference dictionary for connection systems

1 Scope

This part of ISO 13399 specifies a reference dictionary for connection systems for cutting tools, together with their descriptive properties and domains of values.

This part of ISO 13399 specifies a reference dictionary and the structure of interface codes containing:

- definitions and identifications of the classes of connection systems, with an associated classification scheme;
- definitions and identifications of the data element types that represent the properties of connection systems;
- definitions and identifications of domains of values for describing the above data element types;
- definitions and structure of the value entry of the properties of interface codes that are already defined in this International Standard;
- rules for the structure of these properties to be able to communicate between systems.

Each class, property, or domain of values of this application domain constitutes an entry of the reference dictionary defined in this part of ISO 13399. It is associated with a computer-sensible and human-readable definition and with a computer-sensible identification. Identification of a dictionary entry allows unambiguous reference to it from any application that implements the information model defined in ISO 13399-1.

Definitions and identifications of dictionary entries are defined by means of standard data that consist of instances of the EXPRESS entity data types defined in the common dictionary schema, resulting from a joint effort between ISO/TC 184/SC 4 and IEC SC3D, and in its extensions defined in ISO 13584-24 and ISO 13584-25.

The following are within the scope of this part of ISO 13399:

- standard data that represent the various classes of connection systems for cutting tools;
- standard data that represent the various properties of connection systems for cutting tools;
- standard data that represent domains of values used for properties of connection systems for cutting tools;
- one implementation method by which the standard data defined in this part of ISO 13399 can be exchanged.

NOTE 1 The implementation method by which the standard data defined in this part of ISO 13399 can be exchanged is specified in ISO 10303-21.

The following are outside the scope of this part of ISO 13399:

- specialized or expert knowledge on the design and use of cutting tools;
- rules to determine what information should be communicated;

- applications where these standard data can be stored or referenced;
- implementation methods other than the one defined in this part of ISO 13399 by which the standard data can be exchanged and referenced;
- information model for cutting tools;
- definitions of classes and properties for cutting items;
- definitions of classes and properties for tool items;
- definitions of classes and properties for assembly items;
- definitions of classes and properties for reference systems and common concepts.

NOTE 2 The information model for cutting tools is defined in ISO 13399-1.

NOTE 3 The definitions of classes and properties for cutting items, tool items, adaptive items, and assembly items are provided in ISO/TS 13399-2, ISO/TS 13399-3, ISO/TS 13399-4, and ISO/TS 13399-5, respectively.

NOTE 4 The definitions of classes and properties for reference systems and common concepts of general application are defined in ISO/TS 13399-50.

2 Normative references

The following documents, in whole or in part, are normatively referenced in this document and are indispensable for its application. For dated references, only the edition cited applies. For undated references, the latest edition of the referenced document (including any amendments) applies.

ISO 1832:2012, *Indexable inserts for cutting tools — Designation*

ISO 13399-1:2006, *Cutting tool data representation and exchange — Part 1: Overview, fundamental principles and general information model*

ISO/TS 13399-100, *Cutting tool data representation and exchange — Part 100: Definitions, principles and methods for reference dictionaries*

ISO 13584-1:2001, *Industrial automation systems and integration — Parts library — Part 1: Overview and fundamental principles*

3 Terms and definitions

For the purposes of this document, the terms and definitions given in ISO/TS 13399-100 (structure and contents of the dictionary) and the following apply.

NOTE The main collection of the terms and their definitions that relate to adaptive items and their properties is provided in [Annexes B](#) to [D](#).

3.1 applicable property

property that is defined for some family of items and that shall apply to any member of this family

[SOURCE: ISO 13584-24:2003]

3.2 basic semantic unit

entity that provides an absolute and universally unique identification of a certain object of the application domain that is represented as a dictionary element

[SOURCE: ISO 13584-42:2010, 3.4]

**3.3
chip**

material removed from a workpiece by a cutting process

[SOURCE: ISO/TS 13399-2:2014, 3.3]

**3.4
cutting tool**

device or assembly of items for removing material from a workpiece through a shearing action at the defined cutting edge or edges of the device

[SOURCE: ISO 13399-1:2006, 3.1]

Note 1 to entry: A cutting tool could be the assembly of one or more adaptive items, a tool item, and several cutting items on a tool item. See [Figure 1](#).

**3.5
data**

representation of information in a formal manner suitable for communication, interpretation, or processing by human beings or computers

[SOURCE: ISO 10303-1:1994, 3.2.14]

**3.6
data element type**

unit of data for which the identification, description, and value representation have been specified

[SOURCE: ISO 13584-42:2010, 3.13]

**3.7
data exchange**

storing, accessing, transferring, and archiving of data

[SOURCE: ISO 10303-1:1994, 3.2.15]

**3.8
data type**

domain of values

[SOURCE: ISO 10303-11:2004, 3.3.5]

**3.9
dictionary**

table consisting of a series of entries with one meaning corresponding to each entry in the dictionary and one dictionary entry identifying a single meaning

[SOURCE: ISO 13584-511:2006, 3.1.9]

Note 1 to entry: In the ISO 13399 series, a dictionary is a formal and computer-sensible representation of an ontology.

**3.10
entity**

class of information defined by its attributes which establishes a domain of values defined by common attributes and constraints

**3.11
entity data type**

representation of an entity

3.12

entity instance

named unit of data that represents a unit of information within the class defined by an entity

Note 1 to entry: An entity instance is a member of the domain established by an entity data type.

[SOURCE: ISO/TS 13399-2:2014, 3.12]

3.13

family of products

set of products represented by the same characterization class

[SOURCE: ISO 13584-42:2010, 3.16]

3.15

implementation method

means for computers to process or exchange data

3.16

information

facts, concepts, or instructions

[SOURCE: ISO 10303-1:1994, 3.2.20]

3.17

information model

formal model of a bounded set of facts, concepts, or instructions to meet a specific requirement

[SOURCE: ISO 10303-1:1994, 3.2.21]

3.18

machine side

identification of a direction pointing towards the machine

3.19

machined surface

surface produced by the action of a cutting tool

[SOURCE: ISO 3002-1:1982, 3.1.2]

3.20

ontology

explicit and consensual specification of concepts of an application domain independent of any use of these concepts

[SOURCE: ISO 13584-511:2006, 3.1.20]

Note 1 to entry: In the ISO 13399 series, a dictionary is the formal and computer sensible representation of an ontology.

3.21

property

defined parameter suitable for the description and differentiation of products

[SOURCE: ISO 13584-42:2010, 3.37]

3.22

simple family of items

set of items in which each item can be described by the same group of properties

[SOURCE: ISO 13584-42:1998, 3.1.3]

3.23

visible property

property that has a definition meaningful in the scope of a given characterization class, but that does not necessarily apply to the various products belonging to this class

[SOURCE: ISO 13584-42:2010, 3.46]

3.24

workpiece

object on which a cutting action is performed

[SOURCE: ISO/TS 13399-2:2014; 3.24]

3.25

workpiece side

identification of a direction pointing towards the workpiece

4 Abbreviated terms

For the purposes of this document, the following abbreviated terms apply.

BSU basic semantic unit

DET data element type

5 Representation of the ontology concepts as dictionary entries

5.1 General

In [5.2](#), a concept in the ontology is identified by a name in lowercase characters. The name of a class that represents the concept in the dictionary is identified by bold, lowercase characters with multiple words linked by an underscore character.

EXAMPLE “connection interface feature” is the name of a concept in the ontology. **connection interface feature** is the identifier of the class in the dictionary that represents the concept.

Each entry in the dictionary, either a class or a property, is identified with a numerical code (BSU) that is generated at random when the dictionary is compiled. A BSU can be made unique by the addition of a code that is a reference to the supplier of the dictionary.

The structure of the classification is summarized in [Annex B](#). The complete definitions of the classes in this part of ISO 13399 are provided in [Annex C](#). The properties applicable to these classes are defined in [Annex D](#).

5.2 connection interface feature

connection_interface_feature is a generic family of those parts of a tool item or assembly item that form a coupling to another tool item or assembly item or machine tool. Definitions and further subdivision of these classes can be found in [Annex C](#).

connection_interface_feature has the following subclasses:¹⁾

— **ABS_System_Komet**;

1) The identifications for some of these entities are derived from commercial trade names and company names that may be protected. Their use in this part of ISO 13399 is justified by their being in common use with no accepted generic alternatives. This information is given for the convenience of users of this part of ISO 13399 and does not constitute an endorsement by ISO of these products.

- AIF_Adjustable_Interface_Dihart;
- AWN_Prisma_connection_Schwanog;
- BFA_drill_chuck_connection;
- BKA_boring_head_connection;
- BKC_boring_head_connection_Coromant;
- BKI_boring_head_connection_Iscar;
- BRP_Bridgeport_connection;
- BTS_Block_Tool_System_Coromant;
- BUF_boring_and_chamfer_system;
- CBC_Coromant_Bridge_Connection;
- CCB_Coromant_CoroBore;
- CCM_Coromant_Cap_Mounting;
- CCS_Coromant_Capto_system;
- CDB_Coromant_Duobore;
- CFB_Coromant_Fine_Boring;
- CKB_Kaiser_bore_connection;
- CKS_Kaiser_shank_connection;
- CMS_Coromant_Modular_Serrated_mounting;
- CUD_Coromant_U-drill_connection;
- FCM_Flexible_Coupling_Modular_system;
- FDA_milling_arbor_connection;
- FLC_flange_connection_Coromant;
- FLK_flange_connector_Kennametal;
- FTS_Flexible_Tooling_System_Kennametal;
- GMS_Graflex_Modular_System_SECO;
- GRL_Granlund_connection;
- HEE_HE-/HF-system_EMUGE;
- HFS_head_fitting_system_Mapal;
- HSK_hollow_taper_shank;
- HSZ_hollow_cylindrical_shank;
- HTS_deep_drilling_system;
- ICF_Iscar_clickfit_system;
- IMB_modular_connection_system_Iscar;

- IMC_Iscar_metal_cutting_connection;
- KKG_stub_taper;
- KKH_ISO_cartridge_mounting;
- KMB_Kennametal_ModBore_system;
- KMC_Kennametal_cartridge_mounting;
- KMM_Kennametal_Micro_system;
- KMT_KM-UTS_system_Kennametal/Widia;
- KRS_Kennametal_Romicron_system;
- KVT_KV_system_Kennametal;
- MBS_Multi_Blade_System_Coromant;
- MCS_modular_cartridge_system_Kennametal;
- MEG_metric_taper;
- MKG_Morse_taper;
- MVS_modular_connection_system_Wohlhaupter;
- NCT_Novex-NC-Tools_Walter;
- PMC_prismatic_connection_Coromant;
- PMD_prismatic_connection_standard;
- PMI_prismatic_connection_Iscar;
- PMK_prismatic_connection_Kennametal;
- PMS_prismatic_connection_SECO;
- RFX_Rotaflex_system_Widia;
- SAI_screw_connection_Iscar;
- SAC_screw_connection_Coromant;
- SBA_SBA-system_Komet;
- SCA_SECO_cartridge_mounting;
- SCR_SECO_crownlock_connection;
- SKG_Steep_taper;
- SMM_SECO_minimaster;
- SMS_SECO_modular_serrated_connection;
- SPK_holding_arbor;
- SRT_SECO_R_shank;
- STH_automotive_shank;
- SWB_quick_change_connection;

- SZB_collet_shortened_design_Biax;
- SZC_collet_connection_Coromant;
- SZD_collet_connection_standard;
- SZE_collet_connection_Erikson;
- SZP_collet_Eminent_-_Perman;
- SZR_collet_KSF_Roehm;
- SZS_collet_Steinel_Bohrmaster;
- URM_Urma_connection;
- UTS_UTS_Widia;
- VAS_Variant_System_Coromant;
- VKT_rectangular_connection;
- VLS_Varilock_System_Coromant;
- ZYL_cylindrical_shank_connection;
- ZYV_VDI_shank.

6 Properties for connection interface feature

6.1 General

The properties that are applicable to the items defined in [Clause 5](#) are defined in [Annex D](#), where the association of a property with a class is also specified. In the compilation of the dictionary, all properties are visible properties at the root class of the dictionary and are made applicable properties at the class level where they apply. The names of properties that can be applicable to connection interface feature, with their identification codes (BSU), are shown in [Table 1](#). The order of the names in [Table 1](#) should be read in rows from left to right.

NOTE 1 The value domains for properties are specified in ISO/TS 13399-100.

NOTE 2 The BSU can be made unique by the addition of the code for the supplier of the dictionary as a prefix to the identification code.

EXAMPLE The unique BSU for **clamping length** would be: 0112/1///13399_2-71EBAF896BE9A for version two of the dictionary.

Table 1 — Property names and identification codes

Property name	Identification code (BSU)
clamping length	71EBAF896BE9A
clamping length maximum	71ED6E54B15C4
clamping length minimum	71EBB339ED2BD
connection bore depth	71EAC48CAD407
connection code machine side	71D102AE3B252
connection code workpiece side	71D102AE8A5A9
connection size code	71FC193318002
connection unit basis	71ED6E16D5978
coolant supply property	71EBB342CC751
form type	71EBBE32903BD
side	71EBDBF130AE6

Other properties and/or feature classes than the properties that are listed in [Table 1](#) shall be needed to get the string of the interface code created automatically in a computer-sensitive way. The properties

- connection code machine side (CCMS),
- connection code workpiece side (CCWS), and
- insert interface code (IIC)

for making a connection between adaptive items or tool items shall be used for the ability to mount a replaceable cutting item on to a tool item.

6.2 Definition of the structure of connection interface code

The structure of both the connection code machine side and connection code workpiece side is the same. The code shall consist of four symbols if no range of the connection is defined and of eight symbols if a range of possible connections is applied. Connection code designed with 4 symbols is 14 digits and that with 8 symbols is 28 digits long.

The basic structure of the connection interface code is shown in [Table 2](#).

Table 2 — Basic structure of the connection interface code

Symbol	①	②	③	④
Preferred name	connection interface feature class	connection unit base precision	connection size code	connection tolerance class
Preferred symbol		CUBP	CZC	TCDCON
Number of digits	5	1	4	4

Symbol ①: identifies the type and variant of the connection either on the machine side or on the workpiece side. For a connection, the symbol ① shall be same on e.g. the machine side of the tool item and the workpiece side of the adaptive item.

Symbol ②: identifies the precision of the size of a connection. The precision is dependent on the unit base of the connection whether the connection has a metric dimension or an imperial dimension or a coded dimension.

The letter symbol for the precision of the size of a connection is shown in [Table 3](#).

Table 3 — Letter symbol for the precision of the size of a connection

Letter symbol	Description
F	metric range for dimensions 0 mm – 9,999 mm
G	metric range for dimensions 10,00 mm – 99,99 mm
H	metric range for dimensions 100,0 mm – 999,9 mm
M	old entry for the metric dimension designation
R	imperial range for dimensions 0,000 1 inch – 0,999 9 inch
S	imperial range for dimensions 1,000 inch – 9,999 inch
T	imperial range for dimensions 10,00 inch – 99,99 inch
N	old entry for the imperial dimension designation
C	coded design has no unit base (e. g. Morse taper, Steep taper, Polygonal taper shank) representing the size in 1/10 of the value

Symbol ③: identifies the size code of a connection. Property CZC shall be used to fill this symbol.

Examples of coded dimensions based on symbol ② are shown in [Tables 4 to 6](#).

Table 4 — Examples of coded metric dimensions based on symbol ②

Description	Symbol ②	Size code	Dimension
Code “F” for metric range of dimensions from 0,001 mm to 9,999 mm designated in 1/1 000	F	0001	0,001
	F	0210	0,21
	F	8010	8,01
	F	9999	9,999 87 ^a
Code “G” for metric range of dimensions from 10,00 mm to 99,99 mm designated in 1/100	G	1000	10
	G	1687	16,875
	G	5050	50,5
	G	9999	99,995
Code “H” for metric range of dimensions from 100,0 mm to 999,9 mm designated in 1/10	H	1000	100
	H	1024	102,4
	H	2145	214,55
	H	9999	999,9

^a Sizes shall not be rounded, but cut off.

Table 5 — Examples of coded imperial dimensions based on symbol ②

Description	Symbol ②	Size code	Dimension
Code "R" for imperial range of dimensions from 0,000 1 inch to 0,999 9 inch designated in 1/10 000	R	0393	0,039 3
	R	1875	0,187 5 (3/16)
	R	2500	0,25 (1/4)
	R	9999	0,999 9
Code "S" for imperial range of dimensions from 1,000 inch to 9,999 inch designated in 1/1 000	S	1000	1
	S	1015	1,015 625 ^a (1 1/64)
	S	2500	2,5
	S	9999	9,999
Code "T" for imperial range of dimensions from 10,00 inch to 99,99 inch designated in 1/100	T	1025	10,25
	T	2525	25,25
	T	5600	56
	T	9999	99,99

^a Sizes shall not be rounded, but cut off.

Table 6 — Examples of coded non-unit dimensions based on symbol ② "C"

Size code	Symbol ① connection interface feature class				
	CCS01 (ISO 26623)	HSK01 (ISO 12164-1)	KMT01 (ISO 26622)	MKG (ISO 296)	SKG10 (ISO 7388-1)
0000				0	
0010				1	
0020				2	
0030				3	
0040				4	
0050				5	
0060				6	
0250		25			
0300					30
0320	3	32	32		
0400	4	40	40		40
0450					45
0500	5	50	50		50
0600					60
0630	6	63	63		
0650					65
0700					70
0800	8	80	80		
1000	10	100	100		
1250		125			
1600		160			

Symbol ④: identifies the ISO tolerance class of a connection. The first two digits identify the position and the second two digits identify the grade of the tolerance zone; all four digits shall represent the ISO tolerance class. If the position is represented with only one letter, the second digit shall be filled with

the “DOLLAR SIGN” (“\$” – ASCII (hex)-code: 0024) and tolerance grades less than 10 shall be filled with a leading ZERO (0).

EXAMPLE The ISO tolerance class “h7” shall be coded with “h\$07”; the ISO tolerance class “js13” shall be coded with “js13”; the ISO tolerance class “H11” shall be coded with “H\$11”.

For the representation of connection with a range of dimension or tolerances, the connection code shall be structured as shown in [Table 7](#).

Table 7 — Structure of the connection interface code representing ranges

Symbol ①	Symbol ②	Symbol ③	Symbol ④	Symbol ⑤	Symbol ⑥	Symbol ⑦	Symbol ⑧
connection interface feature class	connection unit base precision	connection size code	connection tolerance class	connection interface feature class	connection unit base precision	connection size code	connection tolerance class
	CUBP	CZC	TCDCON		CUBP	CZC	TCDCON
5	1	4	4	5	1	4	4

6.3 Representation of connection interface code

6.3.1 General

The connection interface code shall be applied on the machine side as well as on the workpiece side.

A “DOLLAR SIGN” (\$) shall represent that this digit of the code is not used; an “ASTERISK” (“*” – ASCII (hex)-code: 002A) shall represent that any letter or number is allowed.

6.3.2 Connection code machine side (CCMS)

On the machine side, a range of the connection shall not be applied. Two cases for a connection code machine side are possible.

Case 1 - connection code without defined ISO tolerance class

In case of not showing the coded tolerance class, symbol 4 shall be represented by four “DOLLAR SIGN”s.

EXAMPLE The connection code for a “hollow taper shank type A” (ISO 12164-1) of size 32 shall be created as “HSK01C0320\$\$\$\$”.

Case 2 - connection code with defined ISO tolerance class

If it shall be necessary to show a tolerance class, the tolerance class shall be coded as described with symbol ④.

EXAMPLE The connection code for a “straight cylindrical shank type A” with diameter of 25 mm and tolerance class h7 shall be created as “ZYL01G2500h\$07”.

6.3.3 Connection code workpiece side (CCWS)

On the workpiece side, the connection code with a range can be applied. Three cases are possible on workpiece side.

Case 1 - “exact match” of the connection

For the designation of a connection without defined ISO tolerance class, the connection code on machine side of the item to be connected shall be taken into consideration.

If the connection code of the item to be connected shows the “DOLLAR SIGN”s, the connection code on workpiece side shall also have the “DOLLAR SIGN”s.

EXAMPLE The connection code workpiece side for a “polygonal taper interface with flange contact” of size 4 shall be created as “CCS01C0400\$\$\$\$”.

If the connection code of the item to be connected indicates a tolerance class, the connection code on workpiece side shall have asterisks (*) in symbol 4.

EXAMPLE The connection code workpiece side for a “straight cylindrical hole” with a diameter of 25 mm and no indicated tolerance class shall be created as “ZYL01G2500****”.

Case 2 - connection with a range of dimension

The connection on workpiece side shall represent that connections on machine side of other items between a defined range of dimension can be mounted.

EXAMPLE 1 The connection on workpiece side shall be able to mount “straight cylindrical shanks type A” with diameters from 16,00 mm to 18,50 mm. The connection code shall be designated with “ZYL01G1600****ZYL01G1850****”.

EXAMPLE 2 A drill chuck is able to hold straight cylindrical shanks between 3,00 mm and 13,00 mm. The code shall be designated with “ZYL01F1000****ZYL01G1300****”.



Case 3 - connection with range of tolerances



The connection on workpiece side allows mounting the machine side connections with the same size but with different tolerance classes.

EXAMPLE 3 The connection on workpiece side shall be able to mount “cylindrical shanks with 2° inclined clamping surface” of diameter 20 within the tolerance class h7 or closer. The code shall be designated as “ZYL13G2000h\$00ZYL13G2000h\$07”.

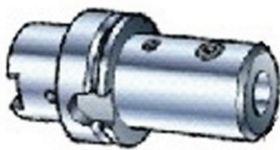







6.3.4 Examples of connection interface codes

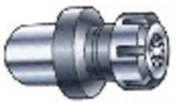

EXAMPLE 1 Exact match between adaptive item and tool item.

			
CCWS	CCMS		

End mill holder - type Weldon connection diameter 16 mm CCWS: ZYL10G1600****	Solid end mill Weldon shank 16 mm h6 CCMS: ZYL10G1600h\$06	☺	
	End mill Weldon shank 20 mm h6 CCMS: ZYL10G2000h\$06	☹	
	Drill Whistle Notch shank 16 mm h6 CCMS: ZYL13G1600h\$06	☹	

EXAMPLE 2 Match of size range between adaptive item and tool item.

				
CCWS	CCMS - CCWS	CCMS		
Collet chuck for collet size ER20 CCWS: SZD02C0200\$\$\$\$	ER collet CCMS: SZD02C0200\$\$\$\$ CCWS: metric ZYL01G1200****ZYL01G1300****	Ball nose end mill straight cylindrical shank 12 mm h7 CCMS: ZYL01G1200h\$07	☺	
		Drill straight cylindrical shank 12,8 mm h6 CCMS: ZYL01G1280h\$06	☺	
		Drill straight cylindrical shank 11 mm h6 CCMS: ZYL01G1100h\$06	☹	
				
CCWS		CCMS		
Drill chuck clamping range: 1 mm - 13 mm CCWS: ZYL01F1000****ZYL01G1300****		Solid carbide drill straight cylindrical shank 14 mm CCMS: ZYL01G1400h\$06	☹	

	Solid carbide drill straight cylindrical shank 6 mm CCMS: ZYL01F6000h\$06	☺	
	Solid carbide drill straight cylindrical shank 10,5 mm CCMS: ZYL01G1050h\$06	☺	

EXAMPLE 3 Match of tolerance range between adaptive item and tool item.





			
CCWS	CCMS		
Collet for hydraulic chuck for shank diameter 12 mm ISO tolerance h7 or closer CCWS: ZYL01G1200h\$00ZYL01G1200h\$07	Solid end mill straight shank 12 mm h6 CCMS: ZYL01G1200h\$06	☺	
	Solid drill straight shank 12 mm h5 CCMS: ZYL01G1200h\$05	☺	
	Grooving boring bar straight boring bar shank 12 mm CCMS: ZYL22G1200\$\$\$\$	☹	

Figure 2 — Example of tolerance range match between adaptive item and tool item

6.4 Representation of insert interface code

6.4.1 General

The structure of the insert interface code is defined and shall be used mandatory without any modifications. Insert interface codes based on national standards that are already in use can be compatible with the symbols 2 to 8.

The insert interface code consists of 12 symbols. The significance of the symbols constituting the designation is as follows.

① Letter symbol identifying	source of code	(6.4.2)
② Letter symbol identifying	insert shape 1	(6.4.3)
③ Letter symbol identifying	insert shape 2	(6.4.4)
④ Number symbol identifying	insert size 1	(6.4.5)
⑤ Number or letter symbol identifying	insert size 2	(6.4.6)
⑥ Number symbol identifying	lower limit of radius	(6.4.7)
⑦ Number symbol identifying	insert mounting style	(6.4.8)
⑧ Letter symbol identifying	hand of insert	(6.4.9)
⑨ Letter symbol identifying	clamping surface	(6.4.10)
⑩ Letter symbol identifying	insert configuration 1	(6.4.11)
⑪ Letter symbol identifying	insert configuration 2	(6.4.12)
⑫ Number symbol identifying	upper limit of radius	(6.4.13)

EXAMPLE 1 insert interface code on cutting item with corner radius – ISO-designated square insert with normal clearance angle 0° cutting edge length 12,7 mm, cutting edge height 4,76 mm, corner radius 0,8 mm, cylindrical fixing hole, neutral handed, flat clamping surface

①	②	③	④	⑤	⑥	⑦	⑧	⑨	⑩	⑪	⑫
ISO\$	S	N	12	04	08	2	N	A	\$	\$	08

EXAMPLE 2 insert interface code on cutting item with wiper – ISO-designated triangle insert with normal clearance angle 15°, cutting edge length 16,49 mm, cutting edge height 3,97 mm, no corner radius, partly cylindrical fixing hole 70° to 90° countersunk, right-handed, non-flatted clamping surface, cutting edge angle 90°, wiper clearance angle 20°

①	②	③	④	⑤	⑥	⑦	⑧	⑨	⑩	⑪	⑫
ISO\$	T	D	16	T3	\$\$	4	R	B	P	E	\$\$

EXAMPLE 3 insert interface code on cutting item with wiper and corner radius – ISO-designated parallelogram-shaped 85° insert with normal clearance angle 11°, cutting edge length 16,49 mm, cutting edge height 5,56 mm, corner radius 1,2 mm, partly cylindrical fixing hole 40° to 60° countersunk on one side, right-handed, non-flatted clamping surface, cutting edge angle 75° wiper clearance angle 15°

①	②	③	④	⑤	⑥	⑦	⑧	⑨	⑩	⑪	⑫
ISO\$	A	P	16	05	12	3	R	B	E	D	12

EXAMPLE 4 insert interface code on tool item for inserts with corner radius – ISO-designated square insert with normal clearance angle 0°, cutting edge length 12,7 mm, cutting edge height 4,76 mm, for max corner radius 1,2 mm, cylindrical fixing hole, neutral handed, flat clamping surface

①	②	③	④	⑤	⑥	⑦	⑧	⑨	⑩	⑪	⑫
ISO\$	S	N	12	04	00	2	N	A	\$	\$	12

6.4.2 Symbol for source of code – reference ①

The symbol (reference ①) is a four-digit long character string. For ISO-designated insert according to ISO 1832, the symbol for the source of code is

ISO\$

For manufacturer’s specific inserts, the code is based on DIN V 4000-100, where a company code for manufacturer is maintained.

EXAMPLE

- **DOR\$** Dormer
- **IS\$\$** ISCAR
- **KH\$\$** Kennametal
- **SO\$\$** SECO TOOLS AB
- **SV\$\$** Sandvik Coromant
- **WR\$\$** Walter AG









All manufacturer not listed shall request a unique code to be able to meet the requirement of this International Standard. Codes that are less than four digits shall be completed by means of adding postfix “DOLLAR SIGNS” (\$).

6.4.3 Symbol for insert shape 1 – reference ②

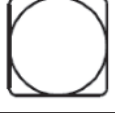
If the source of code (reference ①) is “ISO\$”, the insert shape 1 shall be designated as shown in [Table 8](#). The letter symbol is in accordance to ISO 1832, 4.1, Table 1.

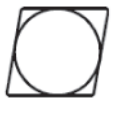
Manufacturer’s specific insert shape shall be designated to manufacturer’s discretion, but it is allowed to use the letter symbols in [Table 8](#), if replaceable cutting items meet the definitions of ISO insert shape.

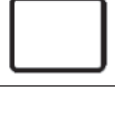
Table 8 — Insert shape 1

Type of insert	Letter symbol	Description	Insert included angle	Figure
Equilateral and equiangular	H	hexagonal	120°	
	O	octogonal	135°	
	P	pentagonal	108°	
	S	square	90°	
	T	triangular	60°	
Equilateral but non-equiangular	C D E M V	rhombic	80° 55° 75° 86° 35°	
	W	trigon	80°	
Non-equilateral and equiangular	L	rectangular	90°	
Non-equilateral and non-equiangular	A	parallelogram-shaped	85°	
	B		82°	
	K		55°	
Round	R	round	-	

The length of the symbol shall be one digit of character string.

6.4.4 Symbol for insert shape 2 – reference ③

If the source of code (reference ①) is “ISO\$”, the insert shape 2 shall be designated as shown in [Table 9](#). The letter symbol is in accordance to ISO 1832, 4.2, Table 2.

Manufacturer’s specific insert shape shall be designated to manufacturer’s discretion, but it is allowed to use the letter symbol in [Table 9](#), if replaceable cutting items meet the definitions of ISO normal clearance.

Table 9 — Insert shape 2

Letter symbol	Clearance angle	Figure
A	3°	
B	5°	
C	7°	
D	15°	
E	20°	
F	25°	
G	30°	
N	0°	
P	11°	
O or X	other	

The length of the symbol shall be one digit of character string.

6.4.5 Symbol for insert size 1 - reference ④

If the source of code (reference ①) is “ISO\$”, the insert size 1 shall be designated as shown in [Table 10](#). The number symbol is in accordance to ISO 1832, 4.5, Table 7 and Table A.1

The length of the symbol shall be two digits of character string.

Manufacturer’s specific insert size shall be designated to manufacturer’s discretion, but it is allowed to use the symbol given in [Table 10](#), if replaceable cutting items meet the metric definitions of ISO insert size.

Table 10 — Insert size 1

Diameter of inscribed circle		Symbol for insert size 1 (reference ④) for insert shape 1 (reference ②)															
		H	O	P	S	T	C	D	E	M	V	W	L	A	B	K	R
mm	inch																
3,97	5/32	-	-	-	03	06	-	04	-	-	06	02	-	-	-	-	-
4,76	3/16	-	-	-	04	08	04	05	04	04	08	L3	-	-	-	-	-
5,56	7/32	-	-	-	05	09	05	06	05	05	09	03	-	-	-	-	-
6,00		-	-	-	-	-	-	-	-	-	-	-	-	-	-	-	06
6,35	1/4	03	02	04	06	11	06	07	06	06	11	04					06
7,94	5/16	04	03	05	07	13	08	09	08	07	13	05					07
8,00		-	-	-	-	-	-	-	-	-	-	-	-	-	-	-	-
9,525	3/8	05	04	07	09	16	09	11	09	09	16	06					09

Table 10 (continued)

Diameter of inscribed circle	Symbol for insert size 1 (reference ④) for insert shape 1 (reference ②)															
	H	O	P	S	T	C	D	E	M	V	W	L	A	B	K	R
10,00	-	-	-	-	-	-	-	-	-	-	-	-	-	-	-	10
12,00	-	-	-	-	-	-	-	-	-	-	-	-	-	-	-	12
12,7	1/2	07	05	09	12	22	12	15	13	12	22	08				12
15,875	5/8	09	06	11	15	27	16	19	16	15	27	10				15
16,00	-	-	-	-	-	-	-	-	-	-	-	-	-	-	-	16
19,05	3/4	11	07	13	19	33	19	23	19	19	33	13				19
20,00	-	-	-	-	-	-	-	-	-	-	-	-	-	-	-	20
25,00	-	-	-	-	-	-	-	-	-	-	-	-	-	-	-	25
25,4	1	14	10	18	25	44	25	31	26	25	44	17				25
31,75	1 1/4	18	13	23	31	54	32	38	32	31	54	21				31
32,00	-	-	-	-	-	-	-	-	-	-	-	-	-	-	-	32



6.4.6 Symbol for insert size 2 - reference ⑤

If the source of code (reference ①) is “ISO\$”, the insert size 2 shall be designated as shown in [Table 11](#). The number symbol is in accordance to ISO 1832, 4.6, Table 8 and Table B.1 with the additions of the number symbols “L4”, “L5”, “L6”, “T6”, and “D2”.

The length of the symbol shall be two digits of character string.

Manufacturer’s specific insert size shall be designated to manufacturer’s discretion, but it is allowed to use the symbol given in [Table 11](#), if replaceable cutting items meet the metric definitions of ISO insert thickness.

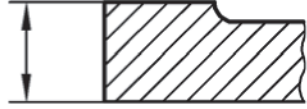
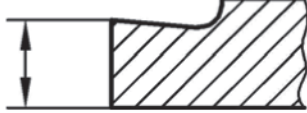
Table 11 — Insert size 2

Insert thickness		Symbol for insert size 2 (reference ⑤)	Figure	
mm	inch			
1,59	1/16	01		
1,98	5/64	T1		
2,38	3/32	02		
3,18	1/8	03		
3,97	5/32	T3		
4,00	-	L4 ^a		
4,76	3/16	04		
5,00	-	L5 ^a		
5,56	7/32	05		
6,00	-	L6 ^a		
6,35	1/4	06		
6,50	-	T6 ^a		
7,94	5/16	07		
8,00	-	08		
9,525	3/8	09		
10,00	-	10		
12,00	-	D2 ^a		
12,70	1/2	12		

^a Additional symbols – not covered in ISO 1832.

6.4.7 Symbol for lower corner radius – reference ⑥

If the source of code (reference ①) is “ISO\$”, the lower corner radius shall be designated as shown in [Table 12](#). The number symbol is in accordance to ISO 1832, 4.7, Table 9 cases 1a) and 3).

For replaceable inserts, the nominal corner radius shall be used for symbol ⑥, which designates the lower corner radius. If the interface code on tool items shall be designated, the lower corner radius shall describe the least radius of the replaceable cutting item that can be mounted on to the tool item without any interference with the workpiece.

The length of the symbol shall be two digits of character string.

Manufacturer’s specific corner configuration shall be designated to manufacturer’s discretion, but it is allowed to use the symbol given in [Table 12](#), if replaceable cutting items meet the metric definitions of ISO rounded corner configuration.

To supplement the designation for round inserts, the following shall be indicated:

- 00 (zero-zero), if the diameter is converted from an inch value;
- M0, if the diameter is a metric one.

Table 12 — Lower corner radius

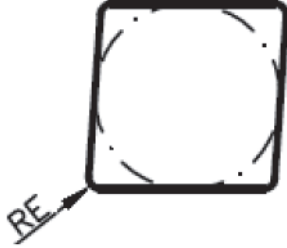





Lower corner radius		Symbol for lower corner radius (reference ⑥)	Figure
mm	inch		
0,00	0,00	00	
0,10	0,003 9	01	
0,20	0,007 9	02	
0,40	0,015 8	04	
0,80	0,031 5	08	
1,20	0,047 2	12	
1,60	0,063 0	16	
2,00	0,078 7	20	
2,40	0,094 5	24	
3,20	0,126 0	32	

6.4.8 Symbol for insert mounting style - reference ⑦

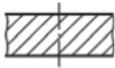
The entry for this symbol is based on the property “insert mounting style code” with its preferred symbol IFS.

It is a one-digit non-quantitative integer type as shown in [Table 13](#).

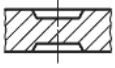
Table 13 — Insert mounting style

Symbol for insert mounting style (reference ⑦)	Figure	Description
0	-	None of the listed below
1		Without fixing hole
2		Cylindrical fixing hole
3		Partly cylindrical, 40° - 60° countersink on one or two sides
4		Partly cylindrical, 70° - 90° countersink on one or two sides
5		Notch clamping
6		Convex prismatic cross section
7		Concave prismatic section

6.4.9 Symbol for hand of insert - reference ⑧

The entry for this symbol is based on the property “insert hand” with its preferred symbol IH.

If the source of code (reference ①) is “ISO\$”, the values of the symbol are mandatory as based on ISO 1832, 5.3, Table 11.

It is a one-digit non-quantitative code type as shown in Table 14.

Table 14 — Insert hand

Symbol for insert hand (reference ⑧)	Corner type	Application of the insert	Figure
R	Right-hand insert	For non-equilateral and non-equiangular inserts and for all inserts with asymmetrical corners and/or asymmetrical chip breaker, permitting the use of the insert in only one direction of the feed motion	
L	Left-hand insert		
N	Neutral insert	For all inserts with symmetrical corners and symmetrical chip breaker, permitting the use of the insert in both directions of the feed motion	

^a Direction of feed motion.

6.4.10 Symbol for clamping surface - reference ⑨

If the source of code (reference ①) is “ISO\$”, the clamping surface shall be designated as shown in Table 15. This symbol shall help to distinguish if e.g. a clamp used for a flat, non-waved surface is needed or such one that is able to clamp replaceable cutting items with chip breaker.

The length of the symbol shall be one digit of character string.

Manufacturer’s specific clamping surfaces shall be designated to manufacturer’s discretion, but it is allowed to use the symbol given in Table 15.

Table 15 — Clamping surface

Symbol for clamping surface (reference ⑨)	Surface type	Figure
A	Flat surface	
B	Non-flatted surface	

6.4.11 Symbol for insert configuration 1 - reference ⑩

If the source of code (reference ①) is “ISO\$”, the insert configuration 1 shall be designated as shown in Table 16. The number symbol is in accordance to ISO 1832, 4.7, Table 9 case 2) for cutting edge angle κ_r .

The length of the symbol shall be one digit of character string.

Manufacturer's specific corner configuration 1 shall be designated to manufacturer's discretion, but it is allowed to use the symbol given in [Table 16](#), if replaceable cutting items meet the definitions of ISO wiper edges designation.

Table 16 — Insert configuration 1

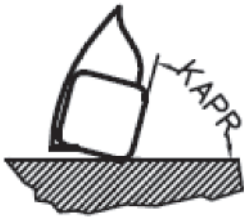
Symbol for insert configuration 1 (reference ⑩)	Cutting edge angle	Figure
A	45°	
D	60°	
E	75°	
F	85°	
G ^b	0°	
H ^a	107,5°	
J ^a	93°	
K ^b	15°	
L ^a	95°	
M ^a	50°	
N ^a	62,5°	
P	90°	
U ^b	117,5°	
V ^a	72,5°	
W ^b	30°	
Z	Any other	

^a Symbol in accordance to ISO 5610-1.
^b Symbol based on cutting edge angles defined in ISO 5610 but given other letters, because of duplicate designation.

6.4.12 Symbol for insert configuration 2 – reference

If the source of code (reference ①) is "ISO\$", the insert configuration 2 shall be designated as shown in [Table 17](#). The number symbol is in accordance to ISO 1832, 4.7, Table 9 case 2) for wiper edge normal clearance angle α_n .

The length of the symbol shall be one digit of character string.

Manufacturer's specific corner configuration 2 shall be designated to manufacturer's discretion, but it is allowed to use the symbol given in [Table 17](#), if replaceable cutting items meet the definitions of ISO wiper edge designation.

Table 17 — Insert configuration 2

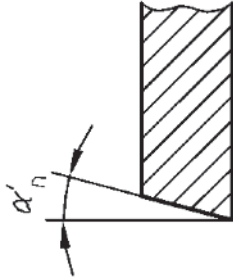
Symbol for insert configuration 2 (reference ⑩)	Wiper edge normal clearance angle	Figure
A	3°	
B	5°	
C	7°	
D	15°	
E	20°	
F	25°	
G	30°	
N	0°	
P	11°	
Z	Any other	

6.4.13 Symbol for upper corner radius – reference

If the source of code (reference ①) is “ISO\$”, the upper corner radius shall be designated as shown in [6.4.7, Table 12](#). The number symbol is in accordance to ISO 1832, 4.7, Table 9 cases 1a) and 3).

If the interface code on replaceable inserts shall be designated, the upper corner radius shall be the nominal radius as the same entry as for the lower corner radius. If the interface code on tool items shall be designated, the upper corner radius shall describe the largest radius of the replaceable cutting item that can be mounted on to the tool item without any interference with the workpiece.

The length of the symbol shall be two digits of character string.

Manufacturer’s specific corner configuration shall be designated to manufacturer’s discretion, but it is allowed to use the symbol given in [Table 12](#), if replaceable cutting items meet the metric definitions of ISO rounded corner configuration.

To supplement the designation for round inserts, the following shall be indicated:

- 00 (zero-zero), if the diameter is converted from an inch value;
- M0, if the diameter is a metric one.

6.4.14 Indication of special signs

The “DOLLAR SIGN” (\$) - ASCII (hex)-code: 0024) shall only be allowed on symbols 6, 10, 11, and 12. It describes that on this position, no value shall be present.

If the \$-sign is on symbol 6, symbols 10 and 11 shall have an entry and on symbol 12, \$-signs are also mandatory.

If the \$-sign is on symbol 10, the symbols 6 and 12 shall have an entry and on symbol 11, a \$-sign is also mandatory.

The “ASTERISK” (*) - ASCII (hex)-code: 002A) shall only be allowed on symbols 6, 10, 11, and 12 and shall only be used for insert interface codes on tool items.

If the *-sign is on symbol 6, any entries according to [6.4.7, Table 12](#) or manufacturer’s specification or the \$-sign are allowed.

If the *-sign is on symbol 10, any entries according to [6.4.11, Table 16](#) or manufacturer’s specification or the \$-sign are allowed.

If the *-sign is on symbol 11, any entries according to [6.4.12](#), [Table 17](#) or manufacturer's specification or the \$-sign are allowed.

If the *-sign is on symbol 12, any entries according to [6.4.7](#), [Table 12](#) or manufacturer's specification or the \$-sign are allowed.

Annex A **(normative)**

Information object registration

A.1 Document identification

In order to provide for unambiguous identification of an information object in an open system, the object identifier:

{iso technical specification 13399 part (60) version (2)}

is assigned to this part of ISO 13399.

The meaning of this value is defined in ISO/IEC 8824-1 and is described in ISO 13584-1.

A.2 Dictionary identification

The dictionary defined in this part of ISO 13399 is assigned the object identifier:

{iso technical specification 13399 part (60) version (2) object (2) connection interface (2)}

Annex B (informative)

Classification table

[Table B.1](#) below shows the classification structure of the generic families in the dictionary with an expanded structure for the class of connection interface feature. The purpose of the table is to show the relationships between the classes related to connection interface feature and the other classes in the ISO 13399 series.

NOTE [Annex C](#) contains the full definition of all the classes that are relevant to connection interface feature. Definitions of reference systems that are used in the definition of some properties can be found in ISO/TS 13399-50.

Table B.1

Classification structure	Parent	BSU
cutting tool library	Root	71CE7A72B6DA7
adaptive item type	71CE7A72B6DA7	71EAD37F18F34
adjustment	71CE7A72B6DA7	71ED884159C90
assembly item type	71CE7A72B6DA7	71CE7A795C05C
bolt hole circle	71CE7A72B6DA7	71E02520881F1
connection interface feature	71CE7A72B6DA7	71DF8C37D9115
ABS System Komet	71DF8C37D9115	71ED66AC44D48
variant 01 of ABS System Komet	71ED66AC44D48	71EF07EABDA7A
variant 02 of ABS System Komet	71ED66AC44D48	71EF07EB0646B
AIF AdjustTable Interface Dihart	71DF8C37D9115	71EF0BAE19FE3
variant 01 of AIF AdjustTable Interface Dihart	71EF0BAE19FE3	71EF0BAE384FA
AWN Prisma connection Schwanog	71DF8C37D9115	71EF0BAE640B8
variant 01 of AWN Prisma connection Schwanog	71EF0BAE640B8	71EF0BAE84362
BFA drill chuck connection	71DF8C37D9115	71ED66B6D07DD
variant 01 of BFA drill chuck connection	71ED66B6D07DD	71EF07FF67B22
variant 02 of BFA drill chuck connection	71ED66B6D07DD	71EF07FF8342C
variant 03 of BFA drill chuck connection	71ED66B6D07DD	71EF07FF9A5F1
BKA boring head connection	71DF8C37D9115	71ED66AC8B274
variant 01 of BKA boring head connection	71ED66AC8B274	71EF07F476F41
variant 02 of BKA boring head connection	71ED66AC8B274	71EF07F4BD4DB
variant 03 of BKA boring head connection	71ED66AC8B274	71EF07F4EADA0
variant 04 of BKA boring head connection	71ED66AC8B274	71EF07F50A5F7
variant 05 of BKA boring head connection	71ED66AC8B274	71EF07F53004D
variant 06 of BKA boring head connection	71ED66AC8B274	71EF07F54F030
BKC boring head connection Coromant	71DF8C37D9115	71ED66B62F072
variant 01 of BKC boring head connection Coromant	71ED66B62F072	71EF08001A258
BKI boring head connection ISCAR	71DF8C37D9115	726F560758ED1
variant 01 of BKI boring head connection ISCAR	726F560758ED1	726F560846C2B
BRP Bridgeport connection	71DF8C37D9115	71ED66B6EEC90

Table B.1

Classification structure	Parent	BSU
variant 01 of BRP Bridgeport connection	71ED66B6EEC90	71EF0804A302F
BTS Block Tool System Coromant	71DF8C37D9115	71ED66B0A4FC6
variant 01 of BTS Block Tool System	71ED66B0A4FC6	71EF0804C4329
BUF boring and chamfer system	71DF8C37D9115	71EF0BAEE28FC
variant 01 of BUF boring and chamfer system	71EF0BAEE28FC	71EF0BAF5FE3B
CBC Coromant Bridge Connection	71DF8C37D9115	71EF0BB8284F3
variant 01 of CBC Coromant bridge connection	71EF0BB8284F3	71EF0BB840816
CCB Coromant CoroBore	71DF8C37D9115	71EF0BB5F2859
variant 01 of CCB Coromant Corobore	71EF0BB5F2859	71EF0BB61BF20
variant 02 of CCB Coromant Corobore	71EF0BB5F2859	71EF0BB6E82EB
CCM Coromant Cap Mounting	71DF8C37D9115	71EF0BB70F7C7
variant 01 of CCM Coromant Cap Mounting	71EF0BB70F7C7	71EF0BB71801D
CCS Coromant Capto System	71DF8C37D9115	71ED66B709CAF
variant 01 of CCS Coromant Capto System	71ED66B709CAF	71EF0804EB914
variant 02 of CCS Coromant Capto System	71ED66B709CAF	721A8AA7F043E
variant 03 of CCS Coromant Capto System	71ED66B709CAF	721A8AA82F15E
variant 04 of CCS Coromant Capto System	71ED66B709CAF	721A8AAC340AF
CDB Coromant Duobore	71DF8C37D9115	71FACDBFF369F
variant 01 of CDB Coromant Duobore	71FACDBFF369F	71FACDC0554A1
variant 02 of CDB Coromant Duobore	71FACDBFF369F	71FACDC1144DE
CFB Coromant Fine Boring	71DF8C37D9115	71EF0BB74011A
variant 01 of CFB Coromant Fine Boring	71EF0BB74011A	71EF0BB74922A
variant 02 of CFB Coromant Fine Boring	71EF0BB74011A	71EF0BB763D01
variant 03 of CFB Coromant Fine Boring	71EF0BB74011A	71EF0BB775C8C
CKB Kaiser bore connection	71DF8C37D9115	71EF0BB792410
variant 01 of CKB Kaiser bore connection	71EF0BB792410	71EF0BB7BEFEC
CKS Kaiser shank connection	71DF8C37D9115	71EF0BB7DFCAE
variant 01 of CKS Kaisernshank connection	71EF0BB7DFCAE	71EF0BB804A8A
CMS Coromant Modular Serrated mounting	71DF8C37D9115	71EF080049770
variant 01 of CMS Coromant Modular Serrated system	71EF080049770	71EF080072664
variant 02 of CMS Coromant Modular Serrated system	71EF080049770	71EF08045D1DC
CUD Coromant U-drill connection	71DF8C37D9115	71FACDC80C1ED
variant 01 of CUD Coromant U-drill connection	71FACDC80C1ED	71FACDC87FE41
FCM Flexible Coupling Modular system	71DF8C37D9115	71ED66ACB787C
variant 01 of FCM Flexible Coupling Modular system	71ED66ACB787C	71EF07F5962C7
variant 02 of FCM Flexible Coupling Modular system	71ED66ACB787C	71EF07F5CC5E9
FDA milling arbor connection	71DF8C37D9115	71ED66ACCAECB
variant 01 of FDA milling arbor	71ED66ACCAECB	71EF07F616F76
variant 02 of FDA milling arbor	71ED66ACCAECB	71EF07F6D9E5E
variant 03 of FDA milling arbor	71ED66ACCAECB	71EF07FB0C25D
variant 11 of FDA milling arbor	71ED66ACCAECB	71EF07FB3EFA1
variant 12 of FDA milling arbor	71ED66ACCAECB	71EF07FB6287C
variant 13 of FDA milling arbor	71ED66ACCAECB	71EF07FB984BB

Table B.1

Classification structure	Parent	BSU
variant 21 of FDA milling arbor	71ED66ACCAECB	71EF07FBDC4EF
variant 22 of FDA milling arbor	71ED66ACCAECB	71EF07FC1A78F
variant 23 of FDA milling arbor	71ED66ACCAECB	71EF07FC4228F
FLC flange connection Coromant	71DF8C37D9115	71EF0BB934E10
variant 01 of FLC flange connection Coromant	71EF0BB934E10	71EF0BB94B9C4
FLK flange connector Kennametal	71DF8C37D9115	71ED66B162A10
variant 02 of FLK flange connection Kennametal	71ED66B162A10	71EF08050689D
variant 03 of FLK flange connection Kennametal	71ED66B162A10	71EF0BB99721C
variant 04 of FLK flange connection Kennametal	71ED66B162A10	71EF0BBE406B1
variant 05 of FLK flange connection Kennametal	71ED66B162A10	71EF0BBE6A270
variant 06 of FLK flange connection Kennametal	71ED66B162A10	71EF0BBE88271
variant 07 of FLK flange connection Kennametal	71ED66B162A10	71EF0BBEA15EE
variant 08 of FLK flange connection Kennametal	71ED66B162A10	71EF0BBEBE60D
variant 09 of FLK flange connection Kennametal	71ED66B162A10	71EF0BBEE8C20
variant 10 of FLK flange connection Kennametal	71ED66B162A10	71EF0BBEFDE0D
variant 11 of FLK flange connection Kennametal	71ED66B162A10	71EF0BBF1AD8C
variant 12 of FLK flange connection Kennametal	71ED66B162A10	71EF0BBF43055
variant 13 of FLK flange connection Kennametal	71ED66B162A10	71EF0BBF4C436
variant 14 of FLK flange connection Kennametal	71ED66B162A10	71EF0BBF67333
variant 15 of FLK flange connection Kennametal	71ED66B162A10	71EF0BBF7F75A
variant 16 of FLK flange connection Kennametal	71ED66B162A10	71EF0BBF9869E
variant 17 of FLK flange connection Kennametal	71ED66B162A10	71EF0BBFBD19F
FTS Flexible Tooling System Kennametal	71DF8C37D9115	71ED66B653708
variant 01 of FTS Flexible Tooling System Kennametal	71ED66B653708	71EF0BBFDAEA7
GMS Graflex Modular System SECO	71DF8C37D9115	71ED66AD18B20
variant 01 of GMS Graflex modular system	71ED66AD18B20	71EF07FC94651
GRL Granlund connection	71DF8C37D9115	71ED66AD3543F
variant 01 of GRL Granlund connection	71ED66AD3543F	71EF07FD3C287
HEE HE-/HF-system EMUGE	71DF8C37D9115	71EF0BC1B193C
variant 01 of HEE HE-/HF system EMUGE	71EF0BC1B193C	71EF0BC26EC04
HFS head fitting system Mapal	71DF8C37D9115	71EF0BC29E34D
variant 01 of HFS head fitting system Mapal	71EF0BC29E34D	71EF0BC2B94A3
HSK hollow taper shank	71DF8C37D9115	71ED66B71F0A5
variant 01 of HSK hollow taper shank	71ED66B71F0A5	71EF0BC00EF7A
variant 02 of HSK hollow taper shank	71ED66B71F0A5	71EF0BC053A2A
variant 03 of HSK hollow taper shank	71ED66B71F0A5	71EF0BC085D25
variant 04 of HSK hollow taper shank	71ED66B71F0A5	71EF0BC0CCD59
HSZ hollow cylindrical shank	71DF8C37D9115	71ED66AD7B0D9
variant 01 of HSZ hollow cylindrical shank	71ED66AD7B0D9	71EF07FD7F301
variant 02 of HSZ hollow cylindrical shank	71ED66AD7B0D9	71EF0BC790F48
variant 03 of HSZ hollow cylindrical shank	71ED66AD7B0D9	71EF0BC7E4010
HTS deep drilling system	71DF8C37D9115	71ED66ADA5674
variant 01 of HTS deep drilling system Kennametal	71ED66ADA5674	71EF0BC823EAA

Table B.1

Classification structure	Parent	BSU
variant 02 of HTS deep drilling system Kennametal	71ED66ADA5674	71EF0BC8D1F91
ICF Iscar clickfit system	71DF8C37D9115	726F5608CC522
variant 01 of ICF system Iscar	726F5608CC522	726F560D0D2B0
IMB modular connection system Iscar	71DF8C37D9115	726F560D5E250
variant 01 of IMB system Iscar	726F560D5E250	726F560DBC5E5
IMC Iscar metal cutting connection	71DF8C37D9115	726F560F8625F
variant 01 of IMC Iscar metal cutting connection	726F560F8625F	726F560FBE036
variant 01 of IMC Iscar metal cutting connection	726F560F8625F	726F561002713
variant 01 of IMC Iscar metal cutting connection	726F560F8625F	726F56104AB8C
KKG stub taper	71DF8C37D9115	71EF0BC91557B
variant 01 of KKG stub taper	71EF0BC91557B	71EF0BC9214D1
variant 02 of KKG stub taper	71EF0BC91557B	71EF0BC949990
KKH ISO cartridge mounting	71DF8C37D9115	71ED66B17CDFB
variant 01 of KKH ISO cartridge mounting	71ED66B17CDFB	71EF0BC984FAA
KMB Kennametal ModBore system	71DF8C37D9115	71ED66B65F546
variant 01 of KMB ModBore System Kennametal	71ED66B65F546	71EF0BC9FBDB7
variant 02 of KMB ModBore System Kennametal	71ED66B65F546	71EF0BCA2A5E6
KMC Kennametal connection	71DF8C37D9115	71ED66B19A2E0
variant 02 of KMC Kennametal cartridge mounting	71ED66B19A2E0	71EF16F685CEF
variant 03 of KMC Kennametal cartridge mounting	71ED66B19A2E0	71EF16F6CC58B
variant 04 of KMC Kennametal cartridge mounting	71ED66B19A2E0	71EF16F6E4567
variant 05 of KMC Kennametal cartridge mounting	71ED66B19A2E0	71EF16F6F9430
variant 06 of KMC Kennametal cartridge mounting	71ED66B19A2E0	71EF16F71619F
variant 07 of KMC Kennametal cartridge mounting	71ED66B19A2E0	71EF16F730A50
variant 08 of KMC Kennametal cartridge mounting	71ED66B19A2E0	71EF16F74607B
variant 09 of KMC Kennametal cartridge mounting	71ED66B19A2E0	71EF16F75CACB
variant 10 of KMC Kennametal cartridge mounting	71ED66B19A2E0	71EF16F773A6B
variant 11 of KMC Kennametal cartridge mounting	71ED66B19A2E0	71EF16F78E88A
variant 12 of KMC Kennametal cartridge mounting	71ED66B19A2E0	71EF16F7AF2F3
variant 13 of KMC Kennametal cartridge mounting	71ED66B19A2E0	71EF16F7D7E43
variant 14 of KMC Kennametal cartridge mounting	71ED66B19A2E0	71EF16F7F009F
variant 15 of KMC Kennametal cartridge mounting	71ED66B19A2E0	71EF16F8038C3
variant 16 of KMC Kennametal cartridge mounting	71ED66B19A2E0	71EF16F810899
variant 17 of KMC Kennametal cartridge mounting	71ED66B19A2E0	71EF16F826471
variant 18 of KMC Kennametal cartridge mounting	71ED66B19A2E0	71EF16F84D9E8
variant 19 of KMC Kennametal cartridge mounting	71ED66B19A2E0	71EF16F858DB9
variant 20 of KMC Kennametal cartridge mounting	71ED66B19A2E0	71EF16F86F70F
variant 21 of KMC Kennametal cartridge mounting	71ED66B19A2E0	71EF16F884E83
variant 22 of KMC Kennametal cartridge mounting	71ED66B19A2E0	71EF16F89C4E9
variant 23 of KMC Kennametal cartridge mounting	71ED66B19A2E0	71EF16F8B170D
variant 24 of KMC Kennametal cartridge mounting	71ED66B19A2E0	71EF16F8BCB2D
variant 25 of KMC Kennametal cartridge mounting	71ED66B19A2E0	71EF16F8D168B
variant 26 of KMC Kennametal cartridge mounting	71ED66B19A2E0	71EF16F91618D

Table B.1

Classification structure	Parent	BSU
KMM Kennametal Micro system	71DF8C37D9115	71EF16F97D172
variant 01 of KMM Kennametal Micro system	71EF16F97D172	71EF16F9A3BAE
variant 02 of KMM Kennametal Micro system	71EF16F97D172	71EF16F9BF2B6
KMT KM-UTS system Kennametal/Widia	71DF8C37D9115	71ED66B74D6DF
variant 01 of KMT KM-UTS system Kennametal/Widia	71ED66B74D6DF	71EF16F9D45A6
variant 02 of KMT KM-UTS system Kennametal/Widia	71ED66B74D6DF	71EF16FA26760
variant 03 of KMT KM-UTS system Kennametal/Widia	71ED66B74D6DF	71EF16FE1F4DB
variant 04 of KMT KM-UTS system Kennametal/Widia	71ED66B74D6DF	71EF16FE2A60C
KRS Kennametal Romicon system	71DF8C37D9115	71ED66B983935
variant 01 of KRS Kennametal Romicon System	71ED66B983935	71EF16FE6C4DD
variant 02 of KRS Kennametal Romicon System	71ED66B983935	71EF16FE88AAB
KVT KV system Kennametal	71DF8C37D9115	71ED66B999EED
variant 01 of KVT KV system Kennametal	71ED66B999EED	71EF16FEBD7E4
variant 02 of KVT KV system Kennametal	71ED66B999EED	71EF16FED3D33
MBS Multi Blade System Coromant	71DF8C37D9115	71EF16FEFE0AF
variant 01 of MBS Multi Blade	71EF16FEFE0AF	71EF16FF1EB17
MCS modular cartridge system Kennametal	71DF8C37D9115	71ED66B1C3A98
variant 01 of MCS modular cartridge system Kennametal	71ED66B1C3A98	71EF16FF5C435
variant 02 of MCS modular cartridge system Kennametal	71ED66B1C3A98	71EF16FF75F49
variant 03 of MCS modular cartridge system Kennametal	71ED66B1C3A98	71EF16FF96879
variant 04 of MCS modular cartridge system Kennametal	71ED66B1C3A98	71EF16FFA94C6
MEG metric taper	71DF8C37D9115	71ED66B9B5DB8
variant 10 of MEG metric taper	71ED66B9B5DB8	71EF1E87A1AFC
variant 11 of MEG metric taper	71ED66B9B5DB8	71EF1E87C88D7
variant 12 of MEG metric taper	71ED66B9B5DB8	71EF1E87D60B5
variant 13 of MEG metric taper	71ED66B9B5DB8	71EF1E87FABF2
variant 20 of MEG metric taper	71ED66B9B5DB8	71EF1E88337E1
variant 21 of MEG metric taper	71ED66B9B5DB8	71EF1E884C33B
variant 22 of MEG metric taper	71ED66B9B5DB8	71EF1E886526B
variant 23 of MEG metric taper	71ED66B9B5DB8	71EF1E887AC99
variant 30 of MEG metric taper	71ED66B9B5DB8	71EF1E88A9D3B
variant 31 of MEG metric taper	71ED66B9B5DB8	71EF1E88D832F
variant 32 of MEG metric taper	71ED66B9B5DB8	71EF1E88F44A3
variant 33 of MEG metric taper	71ED66B9B5DB8	71EF1E89126E9
variant 40 of MEG metric taper	71ED66B9B5DB8	71EF1E8940F72
variant 41 of MEG metric taper	71ED66B9B5DB8	71EF1E895BA49
variant 42 of MEG metric taper	71ED66B9B5DB8	71EF1E8983142
variant 43 of MEG metric taper	71ED66B9B5DB8	71EF1E899E483
MKG Morse taper	71DF8C37D9115	71ED66B9CF5A0
variant 10 of MKG Morse taper	71ED66B9CF5A0	71EF1E89BDD01
variant 11 of MKG Morse taper	71ED66B9CF5A0	71EF1E89EB4C2
variant 12 of MKG Morse taper	71ED66B9CF5A0	71EF1E8A033CA
variant 13 of MKG Morse taper	71ED66B9CF5A0	71EF1E8A1AACC

Table B.1

Classification structure	Parent	BSU
variant 20 of MKG Morse taper	71ED66B9CF5A0	71EF1E8A38E35
variant 21 of MKG Morse taper	71ED66B9CF5A0	71EF1E8E2EE7E
variant 22 of MKG Morse taper	71ED66B9CF5A0	71EF1E8E4A3B4
variant 23 of MKG Morse taper	71ED66B9CF5A0	71EF1E8E797B3
variant 30 of MKG Morse taper	71ED66B9CF5A0	71EF1E8E931E0
variant 31 of MKG Morse taper	71ED66B9CF5A0	71EF1E8EADB27
variant 32 of MKG Morse taper	71ED66B9CF5A0	71EF1E8ECB31A
variant 33 of MKG Morse taper	71ED66B9CF5A0	71EF1E8EF27D8
variant 40 of MKG Morse taper	71ED66B9CF5A0	71EF1E8F157CF
variant 41 of MKG Morse taper	71ED66B9CF5A0	71EF1E8F42243
variant 42 of MKG Morse taper	71ED66B9CF5A0	71EF1E8F6F981
variant 43 of MKG Morse taper	71ED66B9CF5A0	71EF1E8F8B318
MVS modular connection system Wohlhaupter	71DF8C37D9115	71ED66AE75E58
variant 01 of MVS modular connection system Wohlhaupter	71ED66AE75E58	71EF1E8FB6234
NCT Novex-NC-Tools Walter	71DF8C37D9115	71ED66B9F6D76
variant 01 of NCT Novex-NC-Tools Walter	71ED66B9F6D76	71EF1E8FFD738
PMC prismatic connection Coromant	71DF8C37D9115	71EF1E9030508
variant 01 of PMC prismatic connection Coromant	71EF1E9030508	71EF1E906A58B
variant 02 of PMC prismatic connection Coromant	71EF1E9030508	71EF1E9082FF5
variant 04 of PMC prismatic connection Coromant	71EF1E9030508	71EF1E90F24F5
variant 07 of PMC prismatic connection Coromant	71EF1E9030508	71EF1E91159E3
PMD prismatic connection standard	71DF8C37D9115	71ED66B1DF8E1
variant 01 of PMD prismatic connection standard	71ED66B1DF8E1	71EF1E915B0BD
PMI prismatic connection Iscar	71DF8C37D9115	726F560E00E29
variant 01 of PMI prismatic connection Iscar	726F560E00E29	726F560E46BC2
PMK prismatic connection Kennametal	71DF8C37D9115	71ED66B5E2C68
variant 01 of PMK prismatic connection Kennametal	71ED66B5E2C68	71EF1E918967F
PMS prismatic connection SECO	71DF8C37D9115	71EF1E91D5D4F
variant 01 of PMS prismatic connection SECO	71EF1E91D5D4F	71EF1E91EFA2F
RFX Rotaflex system Widia	71DF8C37D9115	71ED66ADD852B
variant 01 of RFX Rotaflex system Widia	71ED66ADD852B	71EF2242723DD
SAC screw connection Coromant	71DF8C37D9115	71EF2242B4D39
variant 01 of SAC screw connection Coromant	71EF2242B4D39	71EF22434D3F1
variant 02 of SAC screw connection Coromant	71EF2242B4D39	71EF2243668E1
variant 03 of SAC screw connection Coromant	71EF2242B4D39	71EF224379DA9
SAI screw connection Iscar	71DF8C37D9115	726F560E9DD9B
variant 01 of SAI screw connection Iscar	726F560E9DD9B	726F560EE02D1
variant 02 of SAI screw connection Iscar	726F560E9DD9B	726F560F2A767
SBA SBA-system Komet	71EF2242B4D39	71EF2242CDE99
variant 01 of SBA SBA-system Komet	71EF2242CDE99	71EF224394D8C
SCA SECO cartridge mounting	71DF8C37D9115	71EF2242E8099
variant 01 of SCA SECO cartridge mounting	71EF2242E8099	71EF2243AFA09
variant 02 of SCA SECO cartridge mounting	71EF2242E8099	71EF2243CB404

Table B.1

Classification structure	Parent	BSU
variant 03 of SCA SECO cartridge mounting	71EF2242E8099	71EF2243E36FF
SCR SECO crownlock connection	71DF8C37D9115	71EF224302CF7
variant 01 of SCR SECO crownlock connection	71EF224302CF7	71EF2247CCF24
SKG Steep taper	71DF8C37D9115	71ED66BA0F1F7
variant 10 of SKG Steep taper	71ED66BA0F1F7	71EF224817F39
variant 11 of SKG Steep taper	71ED66BA0F1F7	71EF2248594F2
variant 16 of SKG Steep taper	71ED66BA0F1F7	71EF2248775E3
variant 17 of SKG Steep taper	71ED66BA0F1F7	71EF22489E8A3
variant 20 of SKG Steep taper	71ED66BA0F1F7	71EF2248B8EAB
variant 21 of SKG Steep taper	71ED66BA0F1F7	71EF2248CF17E
variant 26 of SKG Steep taper	71ED66BA0F1F7	71EF2248DA3F5
variant 27 of SKG Steep taper	71ED66BA0F1F7	71EF22490384F
variant 30 of SKG Steep taper	71ED66BA0F1F7	71EF22492256B
variant 31 of SKG Steep taper	71ED66BA0F1F7	71EF224948944
variant 36 of SKG Steep taper	71ED66BA0F1F7	71EF2249532BC
variant 37 of SKG Steep taper	71ED66BA0F1F7	71EF224979825
variant 40 of SKG Steep taper	71ED66BA0F1F7	71EF224996880
variant 41 of SKG Steep taper	71ED66BA0F1F7	71EF2249B2AF9
variant 46 of SKG Steep taper	71ED66BA0F1F7	71EF2249D9BD8
variant 47 of SKG Steep taper	71ED66BA0F1F7	71EF224A0E1FD
variant 50 of SKG Steep taper	71ED66BA0F1F7	71EF224A4275A
variant 51 of SKG Steep taper	71ED66BA0F1F7	71EF224A59B6E
variant 56 of SKG Steep taper	71ED66BA0F1F7	71EF224A70519
variant 57 of SKG Steep taper	71ED66BA0F1F7	71EF224A8BA27
SMM SECO minimaster	71DF8C37D9115	71EF224AAA436
variant 01 of SMM SECO minimaster	71EF224AAA436	71EF224ADA70A
SMS SECO modular serrated connection	71DF8C37D9115	71EF224ABDBD9
variant 01 of SMS SECO modular serrated connection	71EF224ABDBD9	71EF224AEF279
SPK holding arbor	71DF8C37D9115	71ED66ADFAA9B
variant 01 of SPK holding arbor	71ED66ADFAA9B	71EF25FA05521
variant 02 of SPK holding arbor	71ED66ADFAA9B	71EF25FA3739C
variant 03 of SPK holding arbor	71ED66ADFAA9B	71EF25FA830B8
variant 04 of SPK holding arbor	71ED66ADFAA9B	71EF25FAAB512
variant 05 of SPK holding arbor	71ED66ADFAA9B	71EF25FADB60F
variant 06 of SPK holding arbor	71ED66ADFAA9B	71EF25FAF655C
variant 07 of SPK holding arbor	71ED66ADFAA9B	71EF25FB14928
variant 08 of SPK holding arbor	71ED66ADFAA9B	71EF25FB3DCEC
variant 09 of SPK holding arbor	71ED66ADFAA9B	71EF25FB6D150
variant 10 of SPK holding arbor	71ED66ADFAA9B	71EF25FB8DE89
variant 11 of SPK holding arbor	71ED66ADFAA9B	71EF25FBB4F22
variant 12 of SPK holding arbor	71ED66ADFAA9B	71EF25FC1BBDA
SRT SECO R2 shank	71DF8C37D9115	71EF25FC490BF
variant 01 of SRT SECO R2 shank	71EF25FC490BF	71EF25FC62677

Table B.1

Classification structure	Parent	BSU
STH automotive shank	71DF8C37D9115	71ED66AE29B8D
variant 01 of STH automotive shank	71ED66AE29B8D	71EF25FCB20D6
SWB quick change connection	71DF8C37D9115	71ED66AE588FA
variant 01 of SWB quick change connection	71ED66AE588FA	71F8F4AAB6B82
SZB collet shortened design Biax	71DF8C37D9115	71EF2955BD8F5
variant 01 of SZB collet shortened design Biax	71EF2955BD8F5	71F8F4ACA903C
SZC collet connection Coromant	71DF8C37D9115	71EF2955D5933
variant 01 of SZC collet connection Coromant	71EF2955D5933	71F8F4AD0700A
variant 02 of SZC collet connection Coromant	71EF2955D5933	71F8F4AD0A9D3
SZD collet connection standard	71DF8C37D9115	71ED66BA26E2E
variant 01 of SZD collet connection standard	71ED66BA26E2E	71F8F4ADCFB28
variant 02 of SZD collet connection standard	71ED66BA26E2E	71F8F4ADDFD29
variant 03 of SZD collet connection standard	71ED66BA26E2E	71F8F4ADE49F6
variant 04 of SZD collet connection standard	71ED66BA26E2E	71F8F4ADE904D
variant 11 of SZD collet connection standard	71ED66BA26E2E	71F8F4ADF72B3
variant 12 of SZD collet connection standard	71ED66BA26E2E	71F8F4ADFB413
variant 13 of SZD collet connection standard	71ED66BA26E2E	71F8F4ADFFFF9
SZE collet connection Erikson	71DF8C37D9115	71EF2955F7771
variant 03 of SZE collet connection Erikson	71EF2955F7771	71F8F4AEABB7A
variant 04 of SZE collet connection Erikson	71EF2955F7771	71F8F4AEBB269
SZP collet Eminent-Perman	71DF8C37D9115	71EF29560D5F6
variant 01 of SZP collet Eminent-Perman	71EF29560D5F6	71F8F4AFC5115
SZR collet KSF Roehm	71DF8C37D9115	71EF2956256D4
variant 01 of SZR collet KSF Roehm	71EF2956256D4	71F8F4B457636
SZS collet Steinel Bohrmaster	71DF8C37D9115	71EF29563BB7E
variant 01 of SZS collet Steinel Bohrmaster	71EF29563BB7E	71F8F4B475442
variant 02 of SZS collet Steinel Bohrmaster	71EF29563BB7E	71F8F4B479EA2
variant 03 of SZS collet Steinel Bohrmaster	71EF29563BB7E	71F8F4B47DB96
URM Urma connection	71DF8C37D9115	71EF2956584ED
variant 01 of URM Urma connection	71EF2956584ED	71F8F4B4A6D29
UTS UTS Widia	71DF8C37D9115	71EF29566E0D4
variant 01 of UTS UTS Widia	71EF29566E0D4	71F8F4B4C5B9A
VAS Variant System Coromant	71DF8C37D9115	71ED66AEA108B
variant 01 of VAS Variant System Coromant	71ED66AEA108B	71F8F4B4DF852
VKT rectangular connection	71DF8C37D9115	71ED66B5FAE04
variant 01 of VKT rectangular connection	71ED66B5FAE04	71F8F4B51A785
VLS Varilock System Coromant	71DF8C37D9115	71ED66AEB779
variant 01 of VLS Varilock System Coromant	71ED66AEB779	71F8F4B4F1367
ZYL cylindrical shank connection	71DF8C37D9115	71ED66AF2175B
variant 01 of ZYL cylindrical shank connection	71ED66AF2175B	71F8F4B5348DB
variant 03 of ZYL cylindrical shank connection	71ED66AF2175B	71F8F4B5390AF
variant 04 of ZYL cylindrical shank connection	71ED66AF2175B	71F8F4B53E3D2
variant 10 of ZYL cylindrical shank connection	71ED66AF2175B	71F8F4B54FA0D

Table B.1

Classification structure	Parent	BSU
variant 11 of ZYL cylindrical shank connection	71ED66AF2175B	71F8F4B554639
variant 13 of ZYL cylindrical shank connection	71ED66AF2175B	71F8F4B56465A
variant 14 of ZYL cylindrical shank connection	71ED66AF2175B	71F8F4B56A63D
variant 15 of ZYL cylindrical shank connection	71ED66AF2175B	71F8F4B56FE57
variant 16 of ZYL cylindrical shank connection	71ED66AF2175B	71F8F4B57F583
variant 17 of ZYL cylindrical shank connection	71ED66AF2175B	71F8F4B5853C1
variant 18 of ZYL cylindrical shank connection	71ED66AF2175B	71F8F4B58A106
variant 19 of ZYL cylindrical shank connection	71ED66AF2175B	71F8F4B597D0B
variant 20 of ZYL cylindrical shank connection	71ED66AF2175B	71F8F4B5ACE12
variant 21 of ZYL cylindrical shank connection	71ED66AF2175B	71F8F4B5B212B
variant 22 of ZYL cylindrical shank connection	71ED66AF2175B	71F8F4B5B7D42
variant 23 of ZYL cylindrical shank connection	71ED66AF2175B	71F8F4B5C5EC2
variant 24 of ZYL cylindrical shank connection	71ED66AF2175B	71F8F4B5D1A6B
variant 50 of ZYL cylindrical shank connection	71ED66AF2175B	71F8F4B82CEDE
variant 53 of ZYL cylindrical shank connection	71ED66AF2175B	71F8F4B832F8A
ZYV VDI shank	71DF8C37D9115	71ED66AF4BEFE
variant 01 of ZYV VDI shank	71ED66AF4BEFE	71F8F4B863718
variant 02 of ZYV VDI shank	71ED66AF4BEFE	71F8F4B87213D
coolant supply	71CE7A72B6DA7	71DF8C3C065EB
cutting item feature	71CE7A72B6DA7	71DD6C82F72DA
cutting item type	71CE7A72B6DA7	71D1AA6C8FC75
cutting operation	71CE7A72B6DA7	71DFF83D21D50
cutting tool	71CE7A72B6DA7	71CE7A7A5038B
flange	71CE7A72B6DA7	71EC5A767182E
keyway	71CE7A72B6DA7	71DF5C026BCE7
locking mechanism	71CE7A72B6DA7	71EBAB85BB5FA
reference system	71CE7A72B6DA7	71CF2968F7A9E
runout axial	71CE7A72B6DA7	71EDD2B84143C
runout radial	71CE7A72B6DA7	71EDD2B858274
tool item feature	71CE7A72B6DA7	71DD70376771D
tool item type	71CE7A72B6DA7	71E01A004C775
tool thread external	71CE7A72B6DA7	71FC1D22BF4CD
tool thread internal	71CE7A72B6DA7	71FC1D25097D7

Annex C (informative)

Class definitions

The content of this annex is limited to the classes of connection interface feature.

The layout of the information for each class in this annex is:

BSU Code – version number	Revision number
Preferred name	Short name
Synonymous name	
Definition	
NOTE	
REMARKS	
Subclasses:	
Properties:	
Illustration reference: Figure < Annex.figure number >	

NOTE A particular entry could not have all the elements of the layout.

71DF8C37D9115-001 001

connection interface feature connect

family of features of those parts of a tool item or adaptive item that forms a coupling to another tool item or adaptive item or machine tool

Properties:

- 71D102AE3B252-1 conn code machine side
- 71D102AE8A5A9-1 conn code workpiece side

Subclasses:

- 71ED66AC44D48-001 ABS System Komet
- 71EF0BAE19FE3-001 AIF AdjustTable Interface Dihart
- 71EF0BAE640B8-001 AWN Prisma connection Schwanog
- 71ED66B6D07DD-001 BFA drill chuck connection
- 71ED66AC8B274-001 BKA boring head connection
- 71ED66B62F072-001 BKC boring head connection Coromant
- 726F560758ED1-001 BKI boring head connection Iscar
- 71ED66B6EEC90-001 BRP Bridgeport connection
- 71ED66B0A4FC6-001 BTS Block Tool System Coromant

71EF0BAEE28FC-001 BUF boring and chamfer system
71EF0BB8284F3-001 CBC Coromant Bridge Connection
71EF0BB5F2859-001 CCB Coromant CoroBore
71EF0BB70F7C7-001 CCM Coromant Cap Mounting
71ED66B709CAF-001 CCS Coromant Capto System
71FACDBFF369F-001 CDB Coromant Duobore
71EF0BB74011A-001 CFB Coromant Fine Boring
71EF0BB792410-001 CKB Kaiser bore connection
71EF0BB7DFCAE-001 CKS Kaiser shank connection
71EF080049770-001 CMS Coromant Modular Serrated mounting
71FACDC80C1ED-001 CUD Coromant U-drill connection
71ED66ACB787C-001 FCM Flexible Coupling Modular system
71ED66ACCAECB-001 FDA milling arbor connection
71EF0BB934E10-001 FLC flange connection Coromant
71ED66B162A10-001 FLK flange connector Kennametal
71ED66B653708-001 FTS Flexible Tooling System Kennametal
71ED66AD18B20-001 GMS Graflex Modular System SECO
71ED66AD3543F-001 GRL Granlund connection
71EF0BC1B193C-001 HEE HE-/HF-system EMUGE
71EF0BC29E34D-001 HFS head fitting system Mapal
71ED66B71F0A5-001 HSK hollow taper shank
71ED66AD7B0D9-001 HSZ hollow cylindrical shank
71ED66ADA5674-001 HTS deep drilling system
726F5608CC522-001 ICF Iscar clickfit system
726F560D5E250-001 IMB modular connection system Iscar
726F560F8625F-001 IMC Iscar metal cutting connection
71EF0BC91557B-001 KKG stub taper
71ED66B17CDFB-001 KKH ISO cartridge mounting
71ED66B65F546-001 KMB Kennametal ModBore system
71ED66B19A2E0-001 KMC Kennametal connection
71EF16F97D172-001 KMM Kennametal Micro system
71ED66B74D6DF-001 KMT KM-UTS system Kennametal/Widia
71ED66B983935-001 KRS Kennametal Romicron system

71ED66B999EED-001 KVT KV system Kennametal
71EF16FEFE0AF-001 MBS Multi Blade System Coromant
71ED66B1C3A98-001 MCS modular cartridge system Kennametal
71ED66B9B5DB8-001 MEG metric taper
71ED66B9CF5A0-001 MKG Morse taper
71ED66AE75E58-001 MVS modular connection system Wohlhaupter
71ED66B9F6D76-001 NCT Novex-NC-Tools Walter
71EF1E9030508-001 PMC prismatic connection Coromant
71ED66B1DF8E1-001 PMD prismatic connection standard
726F560E00E29-001 PMI prismatic connection Iscar
71ED66B5E2C68-001 PMK prismatic connection Kennametal
71EF1E91D5D4F-001 PMS prismatic connection SECO
71ED66ADD852B-001 RFX Rotaflex system Widia
726F560E9DD9B-001 SAI screw connection Iscar
71EF2242B4D39-001 SAC screw connection Coromant
71EF2242CDE99-001 SBA SBA-system Komet
71EF2242E8099-001 SCA SECO cartridge mounting
71EF224302CF7-001 SCR SECO crownlock connection
71ED66BA0F1F7-001 SKG Steep taper
71EF224AAA436-001 SMM SECO minimaster
71EF224ABDBD9-001 SMS SECO modular serrated connection
71ED66ADFAA9B-001 SPK holding arbor
71EF25FC490BF-001 SRT SECO R2 shank
71ED66AE29B8D-001 STH automotive shank
71ED66AE588FA-001 SWB quick change connection
71EF2955BD8F5-001 SZB collet shortened design Biax
71EF2955D5933-001 SZC collet connection Coromant
71ED66BA26E2E-001 SZD collet connection standard
71EF2955F7771-001 SZE collet connection Erikson
71EF29560D5F6-001 SZP collet Eminent-Perman
71EF2956256D4-001 SZR collet KSF Roehm
71EF29563BB7E-001 SZS collet Steinel Bohrmaster
71EF2956584ED-001 URM Urma connection

71EF29566E0D4-001 UTS UTS Widia
71ED66AEA108B-001 VAS Variant System Coromant
71ED66B5FAE04-001 VKT rectangular connection
71ED66AEBC779-001 VLS Varilock System Coromant
71ED66AF2175B-001 ZYL cylindrical shank connection
71ED66AF4BEFE-001 ZYV VDI shank

Properties:

71EBAF896BE9A-001 clamping length
71ED6E54B15C4-001 clamping length maximum
71EBB339ED2BD-001 clamping length minimum
71EAC48CAD407-001 connection bore depth
71D102AE3B252-001 connection code machine side
71D102AE8A5A9-001 connection code workpiece side
71FC193318002-001 connection size code
71ED6E16D5978-001 connection unit basis
71EBB342CC751-001 coolant supply property
71EBBE32903BD-002 form type
71EBDBF130AE6-001 side

71ED66AC44D48-001 **001**

ABS System Komet **ABS**

connection of a cylindrical external shape with cylindrical mating surfaces with the values of dimensions conforming to Komet ABS with a sliding pin through the machine side connection to locate into the body of the workpiece side

NOTE ABS is a registered trade mark.

Subclasses:

71EF07EABDA7A-001 variant 01 of ABS System Komet

71EF07EB0646B-001 variant 02 of ABS System Komet

Illustration reference: [Figure E.1](#)

71EF07EABDA7A-001 **001**

variant 01 of ABS System Komet **ABS-01**

normal version of ABS system Komet

71EF07EB0646B-001 **001**

variant 02 of ABS System Komet **ABS-02**

version of ABS System Komet with tenon drive feature conforming to the dimensions of the ABS-N design

71EF0BAE19FE3-001 **001**

AIF AdjusTable Interface Dihart **AIF**

connection of cylindrical external shape with a cylindrical mating surface on the workpiece side and a planar surface secured by screws from the machine side connection

Subclasses:

71EF0BAE384FA-001 variant 01 of AIF AdjusTable Interface Dihart

Illustration reference: [Figure E.2](#)

71EF0BAE384FA-001 **001**

variant 01 of AIF AdjusTable Interface Dihart **AIF-01**

normal version of AIF AdjusTable Interface Dihart

71EF0BAE640B8-001 **001**

AWN Prisma connection Schwanog **AWN**

connection with dovetail mating surfaces conforming to the dimensions of the Schwanog Prisma system

Subclasses:

71EF0BAE84362-001 variant 01 of AWN Prisma connection Schwanog

Illustration reference: [Figure E.3](#)

71EF0BAE84362-001 **001**

variant 01 of AWN Prisma connection Schwanog **AWN-01**

normal version of AWN Prisma connection Schwanog

71ED66B6D07DD-001 **001**

BFA drill chuck connection **BFA**

connection with conical mating surfaces held by an interference fit between the two surfaces

Subclasses:

71EF07FF67B22-001 variant 01 of BFA drill chuck connection

71EF07FF8342C-001 variant 02 of BFA drill chuck connection

71EF07FF9A5F1-001 variant 03 of BFA drill chuck connection

Illustration reference: [Figure E.4](#)

71EF07FF67B22-001 **001**

variant 01 of BFA drill chuck connection **BFA-01**

version of BFA drill chuck connection with dimensions conforming to a Morse taper type

71EF07FF8342C-001 **002**

variant 02 of BFA drill chuck connection **BFA-02**

version of BFA drill chuck connection with dimensions conforming to a Jacobs taper type

71EF07FF9A5F1-001 **001**

variant 03 of BFA drill chuck connection **BFA-03**

version of BFA drill chuck connection with dimensions conforming to a tapered mandrel

71ED66AC8B274-001 **001**

BKA boring head connection **BKA**

connection with flanged mating surfaces located by a central boss and secured by screws into the machine side connector

Subclasses:

71EF07F476F41-001 variant 01 of BKA boring head connection

71EF07F4BD4DB-001 variant 02 of BKA boring head connection

71EF07F4EADA0-001 variant 03 of BKA boring head connection

71EF07F50A5F7-001 variant 04 of BKA boring head connection

71EF07F53004D-001 variant 05 of BKA boring head connection

71EF07F54F030-001 variant 06 of BKA boring head connection

Illustration reference: [Figure E.5](#)

71EF07F476F41-001 **001**

variant 01 of BKA boring head connection **BKA-01**

version of BKA boring head connection for use with interchangeable heads system “H”

71EF07F4BD4DB-001 **001**

variant 02 of BKA boring head connection **BKA-02**

version of BKA boring head connection conforming to the dimensions of the Hertel boring heads system

71EF07F4EADA0-001 **001**

variant 03 of BKA boring head connection **BKA-03**

version of BKA boring head connection for use with adjustable boring heads “A”

71EF07F50A5F7-001 **001**

variant 04 of BKA boring head connection **BKA-04**

version of BKA boring head connection for use with interchangeable screw on heads

71EF07F53004D-001 **001**

variant 05 of BKA boring head connection **BKA-05**

version of BKA boring head connection with dimensions conforming to Erikson tenth set boring ring

71EF07F54F030-001 **001**

variant 06 of BKA boring head connection **BKA-06**

version of BKA boring head connection with dimensions conforming to Erikson tenth set screw-on-boring head

71ED66B62F072-001 **001**

BKC boring head connection Coromant

BKC

connection of generally cylindrical form conforming to the dimensions of the Coromant system 580 for connecting boring tool items secured by locking screws from the periphery of the machine side connector locating in threads in the work piece side connector

NOTE Cormant system 580 is a registered trade name of AB Sandvik Coromant.

Subclasses:

71EF08001A258-001 variant 01 of BKC boring head connection Coromant

Illustration reference: [Figure E.6](#)

71EF08001A258-001

001

variant 01 of BKC boring head connection Coromant

BKC-01

normal version of BKC boring head connection Coromant

726F560758ED1-001

003

BKI boring head connection Iscar

BKI

connection of generally cylindrical form conforming to the dimensions of ISCAR boring head systems for connecting boring tool items secured by locking systems

Subclasses:

726F560846C2B-001 variant 01 of BKI boring head connection Iscar

726F560846C2B-001

003

variant 01 of BKI boring head connection Iscar

BKI01

version of BKI boring head connection for use with interchangeable head of "E-shank system"

71ED66B6EEC90-001

001

BRP Bridgeport connection

BRP

connection with cylindrical mounting surfaces with a conical section at the entry where the machine side connector is located by a pin from the machine side connector that locates in a groove in the workpiece side connector and the assembly is secured by a screw into the workpiece side connector

Subclasses:

71EF0804A302F-001 variant 01 of BRP Bridgeport connection

Illustration reference: [Figure E.7](#)

71EF0804A302F-001

001

variant 01 of BRP Bridgeport connection

BRP-01

normal version of BRP Bridgeport connection with dimensions conforming to R8

71ED66B0A4FC6-001

001

BTS Block Tool System Coromant

BTS

connector with rectangular mating surfaces conforming to the dimensions of the Coromant Block Tool System and a locking mechanism using a male form on the machine side connector that can be withdrawn by a drawbar to expand the workpiece side connector

NOTE Block Tool System is a registered trade name of Sandvik Coromant.

Subclasses:

71EF0804C4329-001 variant 01 of BTS Block Tool System

Illustration reference: [Figure E.8](#)

71EF0804C4329-001	001
variant 01 of BTS Block Tool System	BTS-01

normal version of BTS Block Tool System Coromant

71EF0BAEE28FC-001	001
BUF boring and chamfer system	BUF

connection with cylindrical mating surfaces with components located by a guiding pin and secured by a locking screw

Subclasses:

71EF0BAF5FE3B-001 variant 01 of BUF boring and chamfer system

Illustration reference: [Figure E.9](#)

71EF0BAF5FE3B-001	001
variant 01 of BUF boring and chamfer system	BUF-01

normal version of BUF boring and chamfer system

71EF0BB8284F3-001	001
CBC Coromant Bridge Connection	CBC

connection to a slide in a bridge by means of a keyway slot

Subclasses:

71EF0BB840816-001 variant 01 of CBC Coromant bridge connection

71EF0BB840816-001	001
variant 01 of CBC Coromant bridge connection	CBC-01

normal version of CBC Coromant Bridge Connection

Illustration reference: [Figure E.10](#)

71EF0BB5F2859-001	001
CCB Coromant CoroBore	CCB

connection to hold adjustable cartridges of a boring tool assembly conforming to the dimensions of the Coromant CoroBore system

NOTE CoroBore is a registered trade mark of AB Sandvik Coromant.

Subclasses:

71EF0BB61BF20-001 variant 01 of CCB Coromant Corobore

71EF0BB6E82EB-001 variant 02 of CCB Coromant Corobore

71EF0BB61BF20-001 001

variant 01 of CCB Coromant Corobore CCB-01

version of CCB Coromant Corobore with three cartridges with radial adjustments

Illustration reference: [Figure E.11](#)

71EF0BB6E82EB-001 001

variant 02 of CCB Coromant Corobore CCB-02

version of CCB Coromant Corobore with one cartridge with radial adjustments

Illustration reference: [Figure E.12](#)

71EF0BB70F7C7-001 001

CCM Coromant Cap Mounting CCM

connection of cylindrical form to connect a milling cutter to an arbor secured by screws

Subclasses:

71EF0BB71801D-001 variant 01 of CCM Coromant Cap Mounting

Illustration reference: [Figure E.13](#)

71EF0BB71801D-001 001

variant 01 of CCM Coromant Cap Mounting CCM-01

normal version of a CCM Coromant Cap Mounting

71ED66B709CAF-001 001

CCS Coromant Capto System CCS

connection with mating surfaces in the form of a tapered hollow polygon

NOTE Coromant Capto is a registered trade mark of AB Sandvik Coromant.

Subclasses:

71EF0804EB914-001 variant 01 of CCS Coromant Capto System

721A8AA7F043E-001 variant 02 of CCS Coromant Capto System

721A8AA82F15E-001 variant 03 of CCS Coromant Capto System

721A8AAC340AF-001 variant 04 of CCS Coromant Capto System

Illustration reference: [Figure E.14](#)

71EF0804EB914-001 001

variant 01 of CCS Coromant Capto System CCS-01

normal version of Coromant Capto System with both segment and centre bolt clamping

721A8AA7F043E-001 001

variant 02 of CCS Coromant Capto System **CCS-02**

Coromant Capto System with segment clamping only

721A8AA82F15E-001 **001**

variant 03 of CCS Coromant Capto System **CCS-03**

Coromant Capto System with centre bolt clamping only

721A8AAC340AF-001 **001**

variant 04 of CCS Coromant Capto System **CCS-04**

Coromant Capto System with front clamping

NOTE One drawbolt for each connection is required.

71FACDBFF369F-001 **001**

CDB Coromant Duobore **CDB**

connection between a dual boring cartridge assembly and another adaptive item

NOTE Duobore is a registered trade mark of AB Sandvik Coromant.

Subclasses:

71FACDC0554A1-001 variant 01 of CDB Coromant Duobore

71FACDC1144DE-001 variant 02 of CDB Coromant Duobore

71FACDC0554A1-001 **001**

variant 01 of CDB Coromant Duobore **CDB-01**

version of a connection between a dual boring cartridge assembly and another adaptive item with radial adjustment and axial adjustment by the addition of a shim

Illustration reference: [Figure E.15](#)

71FACDC1144DE-001 **002**

variant 02 of CDB Coromant Duobore **CDB-02**

version of a connection between a dual boring cartridge assembly and another adaptive item with radial adjustment and axial adjustment by movement of a cartridge

Illustration reference: [Figure E.16](#)

71EF0BB74011A-001 **001**

CFB Coromant Fine Boring **CFB**

connection to enable the assembly of a fine boring tool conforming to the dimensions of a Coromant Fine Boring Unit

Subclasses:

71EF0BB74922A-001 variant 01 of CFB Coromant Fine Boring

71EF0BB763D01-001 variant 02 of CFB Coromant Fine Boring

71EF0BB775C8C-001 variant 03 of CFB Coromant Fine Boring

71EF0BB74922A-001	001
variant 01 of CFB Coromant Fine Boring	CFB-01
version of CFB Coromant Fine Boring to hold a cartridge to enable the assembly of a fine boring tool	
Illustration reference:	Figure E.17
71EF0BB763D01-001	001
variant 02 of CFB Coromant Fine Boring	CFB-02
version of CFB Coromant Fine Boring to connect a boring head to a boring adaptor to enable the assembly of a fine boring tool	
Illustration reference:	Figure E.18
71EF0BB775C8C-001	001
variant 03 of CFB Coromant Fine Boring	CFB-03
version of CFB Fine Boring to connect a boring unit into a boring bar secured by three screws into the machine side connector to enable the assembly of a fine boring tool	
Illustration reference:	Figure E.19
71EF0BB792410-001	001
CKB Kaiser bore connection	CKB
connection of cylindrical form with cylindrical mating surfaces located with two diametrical keys on the machine side connector and secured by a pin through the two components with dimensions conforming to Kaiser bore connection	
Subclasses:	
71EF0BB7BEFEC-001 variant 01 of CKB Kaiser bore connection	
Illustration reference:	Figure E.20
71EF0BB7BEFEC-001	001
variant 01 of CKB Kaiser bore connection	CKB-01
normal version of CKB Kaiser bore connection	
71EF0BB7DFCAE-001	001
CKS Kaiser shank connection	CKS
connection of cylindrical form with cylindrical mating surfaces located with two diametrical keys on the machine side connector and secured by a pin through the two components with dimensions conforming to Kaiser shank connection	
Subclasses:	
71EF0BB804A8A-001 variant 01 of CKS Kaisernshank connection	
Illustration reference:	Figure E.21
71EF0BB804A8A-001	001
variant 01 of CKS Kaisernshank connection	CKS-01
normal version of CKS Kaisernshank connection	

71EF080049770-001 **001**

CMS Coromant Modular Serrated mounting **CMS**

connection with a serrated mating surface locked together with screws with the values of the dimensions corresponding to Coromant 570 or Coromant SL

NOTE Coromant 570 and Coromant SL are registered trade names of B Sandvik Coromant.

Illustration reference: [Figure E.22](#)

Subclasses:

71EF080072664-001 variant 01 of CMS Coromant Modular Serrated system

71EF08045D1DC-001 variant 02 of CMS Coromant Modular Serrated system

71EF080072664-001 **001**

variant 01 of CMS Coromant Modular Serrated system **CMS-01**

version of 01 of CMS Coromant Modular Serrated system with truncated ridges and radiused valleys

71EF08045D1DC-001 **001**

variant 02 of CMS Coromant Modular Serrated system **CMS-02**

version of 01 of CMS Coromant Modular Serrated system connection with a serrated mating surface with radiused ridges and valleys

71FACDC80C1ED-001 **001**

CUD Coromant U-drill connection **CUD**

connection for a drill with a whistle-notch shank and a driving lug

Subclasses:

71FACDC87FE41-001 variant 01 of CUD Coromant U-drill connection

Illustration reference: [Figure E.23](#)

71FACDC87FE41-001 **001**

variant 01 of CUD Coromant U-drill connection **CUD-01**

normal version of CUD Coromant U-drill connection

71ED66ACB787C-001 **001**

FCM Flexible Coupling Modular system **FCM**

connection of generally cylindrical form with specific detailed design

Subclasses:

71EF07F5962C7-001 variant 01 of FCM Flexible Coupling Modular system

71EF07F5CC5E9-001 variant 02 of FCM Flexible Coupling Modular system

Illustration reference: [Figure E.24](#)

71EF07F5962C7-001 **002**

variant 01 of FCM Flexible Coupling Modular system **FCM-01**

normal version of FCM Flexible Coupling Modular system

71EF07F5CC5E9-001 **002**

variant 02 of FCM Flexible Coupling Modular system **FCM-02**

FCM-F design of Flexible Coupling Modular system

71ED66ACCAECB-001 **001**

FDA milling arbor connection **FDA**

connection between cylindrical mating surfaces with specific detailed design for a milling arbor

Subclasses:

71EF07F616F76-001 variant 01 of FDA milling arbor

71EF07F6D9E5E-001 variant 02 of FDA milling arbor

71EF07FB0C25D-001 variant 03 of FDA milling arbor

71EF07FB3EFA1-001 variant 11 of FDA milling arbor

71EF07FB6287C-001 variant 12 of FDA milling arbor

71EF07FB984BB-001 variant 13 of FDA milling arbor

71EF07FBDC4EF-001 variant 21 of FDA milling arbor

71EF07FC1A78F-001 variant 22 of FDA milling arbor

71EF07FC4228F-001 variant 23 of FDA milling arbor

Illustration reference: [Figure E.25](#)

71EF07F616F76-001 **001**

variant 01 of FDA milling arbor **FDA-01**

version of FDA milling arbor connection with longitudinal key drive

71EF07F6D9E5E-001 **002**

variant 02 of FDA milling arbor **FDA-02**

transverse key drive

71EF07FB0C25D-001 **001**

variant 03 of FDA milling arbor **FDA-03**

version of FDA milling arbor connection with longitudinal and transverse key drive

71EF07FB3EFA1-001 **001**

variant 11 of FDA milling arbor **FDA-11**

version of FDA milling arbor connection with longitudinal key drive with cutter retaining screw

71EF07FB6287C-001 **001**

variant 12 of FDA milling arbor **FDA-12**

version of FDA milling arbor connection with transverse key drive with cutter retaining screw

71EF07FB984BB-001 **001**
variant 13 of FDA milling arbor **FDA-13**
version of FDA milling arbor connection with longitudinal and transverse key drive with cutter retaining screw

71EF07FBDC4EF-001 **001**
variant 21 of FDA milling arbor **FDA-21**
version of FDA milling arbor connection with longitudinal key drive with socket headed cap screw

71EF07FC1A78F-001 **001**
variant 22 of FDA milling arbor **FDA-22**
version of FDA milling arbor connection with transverse key drive with socket head cap screw

71EF07FC4228F-001 **001**
variant 23 of FDA milling arbor **FDA-23**
version of FDA milling arbor connection with longitudinal and transverse key drive with socket head cap screw

71EF0BB934E10-001 **001**
FLC flange connection Coromant **FLC**
connection with cylindrical mounting surface on the workpiece side connector and a flange connection for the machine side located with a pin and secured by four screws

Subclasses:

71EF0BB94B9C4-001 variant 01 of FLC flange connection Coromant

Illustration reference: [Figure E.26](#)

71EF0BB94B9C4-001 **001**
variant 01 of FLC flange connection Coromant **FLC-01**
normal version of FLC flange connection Coromant

71ED66B162A10-001 **001**
FLK flange connector Kennametal **FLK**
connection with flanged mating surfaces located by a central boss on the workpiece side connector and secured by screws into the machine side connector with dimensions conforming to the Kennametal flange connector

Subclasses:

71EF08050689D-001 variant 02 of FLK flange connection Kennametal

71EF0BB99721C-001 variant 03 of FLK flange connection Kennametal

71EF0BBE406B1-001 variant 04 of FLK flange connection Kennametal

71EF0BBE6A270-001 variant 05 of FLK flange connection Kennametal

71EF0BBE88271-001 variant 06 of FLK flange connection Kennametal

71EF0BBEA15EE-001 variant 07 of FLK flange connection Kennametal
 71EF0BBEBE60D-001 variant 08 of FLK flange connection Kennametal
 71EF0BBEE8C20-001 variant 09 of FLK flange connection Kennametal
 71EF0BBEFDE0D-001 variant 10 of FLK flange connection Kennametal
 71EF0BBF1AD8C-001 variant 11 of FLK flange connection Kennametal
 71EF0BBF43055-001 variant 12 of FLK flange connection Kennametal
 71EF0BBF4C436-001 variant 13 of FLK flange connection Kennametal
 71EF0BBF67333-001 variant 14 of FLK flange connection Kennametal
 71EF0BBF7F75A-001 variant 15 of FLK flange connection Kennametal
 71EF0BBF9869E-001 variant 16 of FLK flange connection Kennametal
 71EF0BBFBD19F-001 variant 17 of FLK flange connection Kennametal

Illustration reference: [Figure E.27](#)

71EF08050689D-001	001
variant 02 of FLK flange connection Kennametal	FLK-02
version of FLK flange connector Kennametal conforming to the dimensions of the design NCM-F	
71EF0BB99721C-001	001
variant 03 of FLK flange connection Kennametal	FLK-03
version of FLK flange connector Kennametal conforming to the dimensions of the design CL2NS-F	
71EF0BBE406B1-001	001
variant 04 of FLK flange connection Kennametal	FLK-04
version of FLK flange connector Kennametal conforming to the dimensions of the design CL2NT-F	
71EF0BBE6A270-001	001
variant 05 of FLK flange connection Kennametal	FLK-05
version of FLK flange connector Kennametal conforming to the dimensions of the designs NCM-EF and CL2N-EF	
71EF0BBE88271-001	001
variant 06 of FLK flange connection Kennametal	FLK-06
version of FLK flange connector Kennametal conforming to the dimensions of the design CLN-EF	
71EF0BBEA15EE-001	001
variant 07 of FLK flange connection Kennametal	FLK-07
version of FLK flange connector Kennametal conforming to the dimensions of the design CLN2NS-BC	
71EF0BBEBE60D-001	001
variant 08 of FLK flange connection Kennametal	FLK-08
version of FLK flange connector Kennametal conforming to the dimensions of the design CLN2NT-BC	

71EF0BBEE8C20-001	001
variant 09 of FLK flange connection Kennametal	FLK-09
version of FLK flange connector Kennametal conforming to the dimensions of the design SA-CLNS	
71EF0BBEFDE0D-001	001
variant 10 of FLK flange connection Kennametal	FLK-10
version of FLK flange connector Kennametal conforming to the dimensions of the design SA-CLNT	
71EF0BBF1AD8C-001	001
variant 11 of FLK flange connection Kennametal	FLK-11
version of FLK flange connector Kennametal conforming to the dimensions of the designs NACA and RACA	
71EF0BBF43055-001	001
variant 12 of FLK flange connection Kennametal	FLK-12
version of FLK flange connector Kennametal conforming to the dimensions of the design NCA-DS	
71EF0BBF4C436-001	001
variant 13 of FLK flange connection Kennametal	FLK-13
version of FLK flange connector Kennametal conforming to the dimensions of the design NCA-DS 16B (KM32)	
71EF0BBF67333-001	001
variant 14 of FLK flange connection Kennametal	FLK-14
version of FLK flange connector Kennametal conforming to the dimensions of the design CLRR UNIVERSAL TURRET	
71EF0BBF7F75A-001	001
variant 15 of FLK flange connection Kennametal	FLK-15
version of FLK flange connector Kennametal conforming to the dimensions of the design CLANN UNIVERSAL TURRET	
71EF0BBF9869E-001	001
variant 16 of FLK flange connection Kennametal	FLK-16
version of FLK flange connector Kennametal conforming to the dimensions of the design NCM-F/EF Micro 4 Bolt	
71EF0BBFBD19F-001	001
variant 17 of FLK flange connection Kennametal	FLK-17
version of FLK flange connector Kennametal conforming to the dimensions of the design NCM-F/EF Micro 4 Bolt	
71ED66B653708-001	001
FTS Flexible Tooling System Kennametal	FTS

connection with serrated mating surfaces with a radial arrangement of serrations conforming to the dimensions of the Kennametal Flexible Tooling System

Subclasses:

71EF0BBFDAAE7-001 variant 01 of FTS Flexible Tooling System Kennametal

Illustration reference: [Figure E.28](#)

71EF0BBFDAAE7-001 **001**
variant 01 of FTS Flexible Tooling System Kennametal **FTS-01**

normal version of the FTS Flexible Tooling System Kennametal

71ED66AD18B20-001 **001**
GMS Graflex Modular System SECO **GMS**

connection between cylindrical mating surfaces with a rectangular boss to locate the machine side connection and with dimensions conforming to the SECO Graflex Modular System

Subclasses:

71EF07FC94651-001 variant 01 of GMS Graflex modular system

Illustration reference: [Figure E.29](#)

71EF07FC94651-001 **001**
variant 01 of GMS Graflex modular system **GMS-01**

normal version of the GMS Graflex Modular System SECO

71ED66AD3543F-001 **001**
GRL Granlund connection **GRL**

connection between cylindrical mating surfaces with a flattened cylindrical surface on the machine side connector and a flat section on the workpiece side connector

Subclasses:

71EF07FD3C287-001 variant 01 of GRL Granlund connection

71EF07FD3C287-001 **001**
variant 01 of GRL Granlund connection **GRL-01**

normal version of GRL Granlund connection

71EF0BC1B193C-001 **001**
HEE HE-/HF-system EMUGE **HEE**

connection between cylindrical mating surfaces with dimensions conforming to the HE and HF systems of EMUGE

Subclasses:

71EF0BC26EC04-001 variant 01 of HEE HE-/HF system EMUGE

71EF0BC26EC04-001 **001**
variant 01 of HEE HE-/HF system EMUGE **HEE-01**

normal version of HEE HE-/HF-system EMUGE

71EF0BC29E34D-001 **001**

HFS head fitting system Mapal **HFS**

connection between conical mating surfaces with dimensions conforming to the Mapal head fitting system

Subclasses:

71EF0BC2B94A3-001 variant 01 of HFS head fitting system Mapal

Illustration reference: [Figure E.32](#)

71EF0BC2B94A3-001 **001**

variant 01 of HFS head fitting system Mapal **HFS-01**

normal version of HFS head fitting system Mapal

71ED66B71F0A5-001 **001**

HSK hollow taper shank **HSK**

connection between conical mating surfaces conforming to the dimensions of the Kennametal HSK design

Subclasses:

71EF0BC00EF7A-001 variant 01 of HSK hollow taper shank

71EF0BC053A2A-001 variant 02 of HSK hollow taper shank

71EF0BC085D25-001 variant 03 of HSK hollow taper shank

71EF0BC0CCD59-001 variant 04 of HSK hollow taper shank

Illustration reference: [Figure E.33](#)

71EF0BC00EF7A-001 **001**

variant 01 of HSK hollow taper shank **HSK-01**

version of HSK hollow taper shank with small planar contact surface with dimensions conforming to the Style A or C

71EF0BC053A2A-001 **001**

variant 02 of HSK hollow taper shank **HSK-02**

version of HSK hollow taper shank with large planar contact surface with dimensions conforming to the Style B or D

71EF0BC085D25-001 **001**

variant 03 of HSK hollow taper shank **HSK-03**

version of HSK hollow taper shank with small planar contact surface with dimensions conforming to the Style E

71EF0BC0CCD59-001 **001**

variant 04 of HSK hollow taper shank **HSK-04**

version of HSK hollow taper shank with large planar contact surface with dimensions conforming to the Style F

71ED66AD7B0D9-001 **001**

HSZ hollow cylindrical shank **HSZ**

connection of generally cylindrical form with specific profiled mating surfaces conforming to the dimensions of the Kennametal hollow cylindrical shank

Subclasses:

71EF07FD7F301-001 variant 01 of HSZ hollow cylindrical shank

71EF0BC790F48-001 variant 02 of HSZ hollow cylindrical shank

71EF0BC7E4010-001 variant 03 of HSZ hollow cylindrical shank

Illustration reference: [Figure E.34](#)

71EF07FD7F301-001 **001**

variant 01 of HSZ hollow cylindrical shank **HSZ-01**

version of HSZ hollow cylindrical shank with a double connection cylinder with small planar contact surface

71EF0BC790F48-001 **001**

variant 02 of HSZ hollow cylindrical shank **HSZ-02**

version of HSZ hollow cylindrical shank with a double connection cylinder with large planar contact surface

71EF0BC7E4010-001 **001**

variant 03 of HSZ hollow cylindrical shank **HSZ-03**

version of HSZ hollow cylindrical shank with a single connection cylinder

71ED66ADA5674-001 **001**

HTS deep drilling system **HTS**

connection for deep drilling tools with cylindrical mating surfaces and projection lugs on the machine side connector and with dimensions conforming to the Kennametal HTS deep drilling system

Subclasses:

71EF0BC823EAA-001 variant 01 of HTS deep drilling system Kennametal

71EF0BC8D1F91-001 variant 02 of HTS deep drilling system Kennametal

Illustration reference: [Figure E.35](#)

71EF0BC823EAA-001 **001**

variant 01 of HTS deep drilling system Kennametal **HTS-01**

normal version of HTS deep drilling system Kennametal

71EF0BC8D1F91-001 **001**

variant 02 of HTS deep drilling system Kennametal **HTS-02**

version of HTS deep drilling system Kennametal conforming to the design HTS-C

726F5608CC522-001 **003**

ICF Iscar clickfit system **ICF**

connection of a cylindrical external shape with cylindrical mating surfaces with the values of dimensions conforming to ISCAR clickfit with a screw on the periphery of the connection on workpiece side to clamp the connection

Subclasses:

726F560D0D2B0-001 variant01 of ICF system Iscar

726F560D0D2B0-001 **003**

variant 01 of ICF system Iscar **ICF01**

normal version of ICF system ISCAR

726F560D5E250-001 **003**

IMB modular connection system Iscar **IMB**

connection of a cylindrical external shape with tapered mating surfaces with the values of dimensions conforming to ISCAR MB modular connection system

Subclasses:

726F560DBC5E5-001 variant01 of IMB system Iscar

726F560DBC5E5-001 **003**

variant 01 of IMB system Iscar **IMB01**

normal version of IMB system ISCAR

726F560F8625F-001 **003**

IMC Iscar metal cutting connection **IMC**

connection to a specific detailed design for holding cutting tool components excluding cutting items

Subclasses:

726F560FBE036-001 variant01 of IMC Iscar metal cutting connection

726F561002713-001 variant02 of IMC Iscar metal cutting connection

726F56104AB8C-001 variant03 of IMC Iscar metal cutting connection

726F560FBE036-001 **003**

variant 01 of IMC Iscar metal cutting connection **IMC01**

version of Iscar metal cutting connection of modular grip

726F561002713-001 **003**

variant 02 of IMC Iscar metal cutting connection **IMC02**

version of Iscar metal cutting connection of cut grip for GAIR/L

726F56104AB8C-001 **003**

variant 03 of IMC Iscar metal cutting connection IMC03

version of Iscar metal cutting connection of cut grip for GHIC

71EF0BC91557B-001 **001**

KKG stub taper **KKG**

connection between conical mating surfaces with specific detailed design

Subclasses:

71EF0BC9214D1-001 variant 01 of KKG stub taper

71EF0BC949990-001 variant 02 of KKG stub taper

Illustration reference: [Figure E.36](#)

71EF0BC9214D1-001 **001**

variant 01 of KKG stub taper **KKG-01**

version of KKG stub taper conforming to the dimensions of the design from Bilz

71EF0BC949990-001 **001**

variant 02 of KKG stub taper **KKG-02**

version of KKG stub taper conforming to the dimensions of the design from Dihart

71ED66B17CDFB-001 **001**

KKH ISO cartridge mounting **KKH**

connection to enable the mounting of a cartridge specified in ISO 5611

Subclasses:

71EF0BC984FAA-001 variant 01 of KKH ISO cartridge mounting

Illustration reference: [Figure E.37](#)

71EF0BC984FAA-001 **001**

variant 01 of KKH ISO cartridge mounting **KKH-01**

normal version of KKH ISO cartridge mounting

71ED66B65F546-001 **001**

KMB Kennametal ModBore system **KMB**

connection between serrated mating surfaces with a parallel arrangement of serrations and with dimensions conforming to the Kennametal ModBore System

Subclasses:

71EF0BC9FBDB7-001 variant 01 of KMB ModBore System Kennametal

71EF0BCA2A5E6-001 variant 02 of KMB ModBore System Kennametal

71EF0BC9FBDB7-001 **001**

variant 01 of KMB ModBore System Kennametal **KMB-01**

version of KMB Kennametal ModBore system for making a bridge tool connection with extension bridges

71EF0BCA2A5E6-001

001

variant 02 of KMB ModBore System Kennametal

KMB-02

version of KMB Kennametal ModBore system for making a bridge tool for fine boring heads

71ED66B19A2E0-001

001

KMC Kennametal connection

KMC

connection to a specific detailed design for holding components of cutting tools excluding cutting items

Subclasses:

71EF16F685CEF-001 variant 02 of KMC Kennametal cartridge mounting

71EF16F6CC58B-001 variant 03 of KMC Kennametal cartridge mounting

71EF16F6E4567-001 variant 04 of KMC Kennametal cartridge mounting

71EF16F6F9430-001 variant 05 of KMC Kennametal cartridge mounting

71EF16F71619F-001 variant 06 of KMC Kennametal cartridge mounting

71EF16F730A50-001 variant 07 of KMC Kennametal cartridge mounting

71EF16F74607B-001 variant 08 of KMC Kennametal cartridge mounting

71EF16F75CACB-001 variant 09 of KMC Kennametal cartridge mounting

71EF16F773A6B-001 variant 10 of KMC Kennametal cartridge mounting

71EF16F78E88A-001 variant 11 of KMC Kennametal cartridge mounting

71EF16F7AF2F3-001 variant 12 of KMC Kennametal cartridge mounting

71EF16F7D7E43-001 variant 13 of KMC Kennametal cartridge mounting

71EF16F7F009F-001 variant 14 of KMC Kennametal cartridge mounting

71EF16F8038C3-001 variant 15 of KMC Kennametal cartridge mounting

71EF16F810899-001 variant 16 of KMC Kennametal cartridge mounting

71EF16F826471-001 variant 17 of KMC Kennametal cartridge mounting

71EF16F84D9E8-001 variant 18 of KMC Kennametal cartridge mounting

71EF16F858DB9-001 variant 19 of KMC Kennametal cartridge mounting

71EF16F86F70F-001 variant 20 of KMC Kennametal cartridge mounting

71EF16F884E83-001 variant 21 of KMC Kennametal cartridge mounting

71EF16F89C4E9-001 variant 22 of KMC Kennametal cartridge mounting

71EF16F8B170D-001 variant 23 of KMC Kennametal cartridge mounting

71EF16F8BCB2D-001 variant 24 of KMC Kennametal cartridge mounting

71EF16F8D168B-001 variant 25 of KMC Kennametal cartridge mounting

71EF16F91618D-001 variant 26 of KMC Kennametal cartridge mounting

71EF16F685CEF-001

001

variant 02 of KMC Kennametal cartridge mounting	KMC-02
version of KMC Kennametal cartridge mounting for holding a milling cartridge	
71EF16F6CC58B-001	001
variant 03 of KMC Kennametal cartridge mounting	KMC-03
version of KMC Kennametal cartridge mounting for holding Erikson tenth set cartridges	
71EF16F6E4567-001	001
variant 04 of KMC Kennametal cartridge mounting	KMC-04
version of KMC Kennametal cartridge mounting for holding a Fix Perfect cartridge	
71EF16F6F9430-001	001
variant 05 of KMC Kennametal cartridge mounting	KMC-05
version of KMC Kennametal cartridge mounting for holding Kendex units	
71EF16F71619F-001	001
variant 06 of KMC Kennametal cartridge mounting	KMC-06
version of KMC Kennametal cartridge mounting for holding an HTS Drill Cartridge	
71EF16F730A50-001	001
variant 07 of KMC Kennametal cartridge mounting	KMC-07
version of KMC Kennametal cartridge mounting for holding an HTSR Drill cartridge	
71EF16F74607B-001	001
variant 08 of KMC Kennametal cartridge mounting	KMC-08
version of KMC Kennametal cartridge mounting for holding an FAS Drill Chamfering cartridge	
71EF16F75CACB-001	001
variant 09 of KMC Kennametal cartridge mounting	KMC-09
version of KMC Kennametal cartridge mounting for holding a Facemill Wiper Cartridge	
71EF16F773A6B-001	001
variant 10 of KMC Kennametal cartridge mounting	KMC-10
version of KMC Kennametal cartridge mounting for holding a Fix Perfect Milling Cartridge mounting conforming to the dimension of 4,190	
71EF16F78E88A-001	001
variant 11 of KMC Kennametal cartridge mounting	KMC-11
version of KMC Kennametal cartridge mounting for holding a Facemill/Endmill Wedge Lock PCD Cartridge (Steel Body)	
71EF16F7AF2F3-001	001
variant 12 of KMC Kennametal cartridge mounting	KMC-12

version of KMC Kennametal cartridge mounting for holding a Facemill Screw-on PCD cartridge (Aluminium body)

71EF16F7D7E43-001 **001**

variant 13 of KMC Kennametal cartridge mounting **KMC-13**

version of KMC Kennametal cartridge mounting for holding a Facemill Screw-on Cartridge

71EF16F7F009F-001 **001**

variant 14 of KMC Kennametal cartridge mounting **KMC-14**

version of KMC Kennametal cartridge mounting for holding a Endmill Screw-on Cartridge

71EF16F8038C3-001 **001**

variant 15 of KMC Kennametal cartridge mounting **KMC-15**

version of KMC Kennametal cartridge mounting for holding a Romicron SVS Cartridge

71EF16F810899-001 **001**

variant 16 of KMC Kennametal cartridge mounting **KMC-16**

version of KMC Kennametal cartridge mounting for holding a Romicron SVU Cartridge

71EF16F826471-001 **001**

variant 17 of KMC Kennametal cartridge mounting **KMC-17**

version of KMC Kennametal cartridge mounting for holding a Romicron Modular Cartridge

71EF16F84D9E8-001 **001**

variant 18 of KMC Kennametal cartridge mounting **KMC-18**

version of KMC Kennametal cartridge mounting for holding a Romicron Modular Unit

71EF16F858DB9-001 **001**

variant 19 of KMC Kennametal cartridge mounting **KMC-19**

version of KMC Kennametal cartridge mounting for holding a M400 Milling Cartridge

71EF16F86F70F-001 **001**

variant 20 of KMC Kennametal cartridge mounting **KMC-20**

version of KMC Kennametal cartridge mounting for holding a M900 Milling Cartridge

71EF16F884E83-001 **001**

variant 21 of KMC Kennametal cartridge mounting **KMC-21**

version of KMC Kennametal cartridge mounting for holding a Dial Set Blade Set Cartridge

71EF16F89C4E9-001 **001**

variant 22 of KMC Kennametal cartridge mounting **KMC-22**

version of KMC Kennametal cartridge mounting for holding a MODBORE Twin Cutter Cartridge

71EF16F8B170D-001 **001**

variant 23 of KMC Kennametal cartridge mounting **KMC-23**

version of KMC Kennametal cartridge mounting for holding a MODBORE Fine Boring Head Cartridge

71EF16F8BCB2D-001 **001**

variant 24 of KMC Kennametal cartridge mounting **KMC-24**

version of KMC Kennametal cartridge mounting for holding a MODBORE BT Rough Bore Head Cartridge

71EF16F8D168B-001 **001**

variant 25 of KMC Kennametal cartridge mounting **KMC-25**

version of KMC Kennametal cartridge mounting for holding Cylindrical Clamping Cartridge with collars and chamfer rings

71EF16F91618D-001 **001**

variant 26 of KMC Kennametal cartridge mounting **KMC-26**

version of KMC Kennametal cartridge mounting for holding an RR Wheel Turning MM Cartridge

71EF16F97D172-001 **001**

KMM Kennametal Micro system **KMM**

connection between conical mating surfaces with the female location on the workpiece side connector and conforming to the dimensions of the Kennametal Micro system

Subclasses:

71EF16F9A3BAE-001 variant 01 of KMM Kennametal Micro system

71EF16F9BF2B6-001 variant 02 of KMM Kennametal Micro system

Illustration reference: [Figure E.38](#)

71EF16F9A3BAE-001 **001**

variant 01 of KMM Kennametal Micro system **KMM-01**

normal version of KMM Kennametal Micro system

REMARK Previously known as KMR

71EF16F9BF2B6-001 **001**

variant 02 of KMM Kennametal Micro system **KMM-02**

version of KMM Kennametal Micro system with an enlarged flange design

71ED66B74D6DF-001 **001**

KMT KM-UTS system Kennametal/Widia **KMT**

connection between complex conical mating surfaces conforming to the dimensions of the Kennametal/Widia UTS system located by a pin through the two components

Subclasses:

71EF16F9D45A6-001 variant 01 of KMT KM-UTS system Kennametal/Widia

71EF16FA26760-001 variant 02 of KMT KM-UTS system Kennametal/Widia

71EF16FE1F4DB-001 variant 03 of KMT KM-UTS system Kennametal/Widia

71EF16FE2A60C-001 variant 04 of KMT KM-UTS system Kennametal/Widia

Illustration reference: [Figure E.39](#)

71EF16F9D45A6-001 001

variant 01 of KMT KM-UTS system Kennametal/Widia KMT-01

normal version of KMT KM-UTS system Kennametal/Widia

71EF16FA26760-001 001

variant 02 of KMT KM-UTS system Kennametal/Widia KMT-02

version of KMT KM-UTS system Kennametal/Widia with an enlarged flange

71EF16FE1F4DB-001 001

variant 03 of KMT KM-UTS system Kennametal/Widia KMT-03

version of KMT KM-UTS system Kennametal/Widia with three holes for an automatic tool changer

71EF16FE2A60C-001 001

variant 04 of KMT KM-UTS system Kennametal/Widia KMT-04

version of KMT KM-UTS system Kennametal/Widia with four holes for an automatic tool changer

71ED66B983935-001 001

KRS Kennametal Romicon system KRS

connection between conical mating surfaces and making a connection to a screw protruding from the machine

Subclasses:

71EF16FE6C4DD-001 variant 01 of KRS Kennametal Romicon System

71EF16FE88AAB-001 variant 02 of KRS Kennametal Romicon System

Illustration reference: [Figure E.40](#)

71EF16FE6C4DD-001 001

variant 01 of KRS Kennametal Romicon System KRS-01

normal version of KRS Kennametal Romicon system

71EF16FE88AAB-001 001

variant 02 of KRS Kennametal Romicon System KRS-02

version of KRS Kennametal Romicon system conforming to the design of the SVU serrated flange mount

71ED66B999EED-001 001

KVT KV system Kennametal KVT

connection between conical mating surfaces with a central location for the workpiece side connector and conforming to the dimensions of the Kennametal KV system

Subclasses:

71EF16FEBD7E4-001 variant 01 of KVT KV system Kennametal

71EF16FED3D33-001 variant 02 of KVT KV system Kennametal

Illustration reference: [Figure E.41](#)

71EF16FEBD7E4-001	001
variant 01 of KVT KV system Kennametal	KVT-01
normal version of the KVT KV system Kennametal	
71EF16FED3D33-001	001
variant 02 of KVT KV system Kennametal	KVT-02
version of KVT KV system Kennametal with enlarged flange	
71EF16FEFE0AF-001	001
MBS Multi Blade System Coromant	MBS

connection between a grooving or parting blade and a tool shank with dimensions conforming to the Coromant Multi Blade System

Subclasses:

71EF16FF1EB17-001 variant 01 of MBS Multi Blade

Illustration reference: [Figure E.42](#)

71EF16FF1EB17-001	001
variant 01 of MBS Multi Blade	MBS-01
normal version of the MBS Multi Blade System Coromant	
71ED66B1C3A98-001	001
MCS modular cartridge system Kennametal	MCS
connection to enable the holding of a cartridge for specific applications	

Subclasses:

71EF16FF5C435-001 variant 01 of MCS modular cartridge system Kennametal

71EF16FF75F49-001 variant 02 of MCS modular cartridge system Kennametal

71EF16FF96879-001 variant 03 of MCS modular cartridge system Kennametal

71EF16FFA94C6-001 variant 04 of MCS modular cartridge system Kennametal

71EF16FF5C435-001	001
variant 01 of MCS modular cartridge system Kennametal	MCS-01
version of MCS modular cartridge system Kennametal for use for deep grooving	
71EF16FF75F49-001	001
variant 02 of MCS modular cartridge system Kennametal	MCS-02
version of MCS modular cartridge system Kennametal for use for Kendex 2000	
71EF16FF96879-001	001
variant 03 of MCS modular cartridge system Kennametal	MCS-03

version of MCS modular cartridge system Kennametal for use for 411-VR

71EF16FFA94C6-001 **001**
variant 04 of MCS modular cartridge system Kennametal **MCS-04**

version of MCS modular cartridge system Kennametal for use for ranger cartridge

71ED66B9B5DB8-001 **001**
MEG metric taper **MEG**

connection between conical mating surfaces with specific details of the design and dimensions in metric units

Subclasses:

71EF1E87A1AFC-001 variant 10 of MEG metric taper
71EF1E87C88D7-001 variant 11 of MEG metric taper
71EF1E87D60B5-001 variant 12 of MEG metric taper
71EF1E87FABF2-001 variant 13 of MEG metric taper
71EF1E88337E1-001 variant 20 of MEG metric taper
71EF1E884C33B-001 variant 21 of MEG metric taper
71EF1E886526B-001 variant 22 of MEG metric taper
71EF1E887AC99-001 variant 23 of MEG metric taper
71EF1E88A9D3B-001 variant 30 of MEG metric taper
71EF1E88D832F-001 variant 31 of MEG metric taper
71EF1E88F44A3-001 variant 32 of MEG metric taper
71EF1E89126E9-001 variant 33 of MEG metric taper
71EF1E8940F72-001 variant 40 of MEG metric taper
71EF1E895BA49-001 variant 41 of MEG metric taper
71EF1E8983142-001 variant 42 of MEG metric taper
71EF1E899E483-001 variant 43 of MEG metric taper

Illustration reference: [Figure E.43](#)

71EF1E87A1AFC-001 **001**
variant 10 of MEG metric taper **MEG-10**

version of MEG metric taper with attachment thread but without coolant supply

71EF1E87C88D7-001 **001**
variant 11 of MEG metric taper **MEG-11**

version of MEG metric taper with attachment thread and with axial coolant entry

71EF1E87D60B5-001 **001**
variant 12 of MEG metric taper **MEG-12**

version of MEG metric taper with attachment thread and with radial coolant entry

71EF1E87FABF2-001 **001**

variant 13 of MEG metric taper **MEG-13**

version of MEG metric taper with attachment thread and with axial and radial coolant entry

71EF1E88337E1-001 **001**

variant 20 of MEG metric taper **MEG-20**

with tenon without coolant supply

71EF1E884C33B-001 **001**

variant 21 of MEG metric taper **MEG-21**

version of MEG metric taper with tenon and with axial coolant entry

71EF1E886526B-001 **001**

variant 22 of MEG metric taper **MEG-22**

version of MEG metric taper with tenon and with radial coolant entry

71EF1E887AC99-001 **001**

variant 23 of MEG metric taper **MEG-23**

version of MEG metric taper with tenon and with axial and radial coolant entry

71EF1E88A9D3B-001 **001**

variant 30 of MEG metric taper **MEG-30**

version of MEG metric taper with tenon and hold back key but without coolant supply

71EF1E88D832F-001 **001**

variant 31 of MEG metric taper **MEG-31**

version of MEG metric taper with tenon and hold back key and with axial coolant entry

71EF1E88F44A3-001 **001**

variant 32 of MEG metric taper **MEG-32**

version of MEG metric taper with tenon and hold back key and with radial coolant entry

71EF1E89126E9-001 **001**

variant 33 of MEG metric taper **MEG-33**

version of MEG metric taper with tenon and hold back key and with axial and radial coolant entry

71EF1E8940F72-001 **001**

variant 40 of MEG metric taper **MEG-40**

version of MEG metric taper with attachment thread and positive drive but without coolant supply

71EF1E895BA49-001 **001**

variant 41 of MEG metric taper **MEG-41**

version of MEG metric taper with attachment thread and positive drive and with axial coolant entry

71EF1E8983142-001 **001**
variant 42 of MEG metric taper **MEG-42**

version of MEG metric taper with attachment thread and positive drive and with radial coolant entry

71EF1E899E483-001 **001**
variant 43 of MEG metric taper **MEG-43**

version of MEG metric taper with attachment thread and positive drive with axial and radial coolant entry

71ED66B9CF5A0-001 **001**
MKG Morse taper **MKG**

connection between conical mating surfaces with specific details of the design

Subclasses:

71EF1E89BDD01-001 variant 10 of MKG Morse taper
71EF1E89EB4C2-001 variant 11 of MKG Morse taper
71EF1E8A033CA-001 variant 12 of MKG Morse taper
71EF1E8A1AACC-001 variant 13 of MKG Morse taper
71EF1E8A38E35-001 variant 20 of MKG Morse taper
71EF1E8E2EE7E-001 variant 21 of MKG Morse taper
71EF1E8E4A3B4-001 variant 22 of MKG Morse taper
71EF1E8E797B3-001 variant 23 of MKG Morse taper
71EF1E8E931E0-001 variant 30 of MKG Morse taper
71EF1E8EADB27-001 variant 31 of MKG Morse taper
71EF1E8ECB31A-001 variant 32 of MKG Morse taper
71EF1E8EF27D8-001 variant 33 of MKG Morse taper
71EF1E8F157CF-001 variant 40 of MKG Morse taper
71EF1E8F42243-001 variant 41 of MKG Morse taper
71EF1E8F6F981-001 variant 42 of MKG Morse taper
71EF1E8F8B318-001 variant 43 of MKG Morse taper

Illustration reference: [Figure E.44](#)

71EF1E89BDD01-001 **001**
variant 10 of MKG Morse taper **MKG-10**

version of MKG Morse taper with attachment thread but without coolant supply

71EF1E89EB4C2-001 **001**
variant 11 of MKG Morse taper **MKG-11**

version of MKG Morse taper with attachment thread and with axial coolant entry	
71EF1E8A033CA-001	001
variant 12 of MKG Morse taper	MKG-12
version of MKG Morse taper with attachment thread and with radial coolant entry	
71EF1E8A1AACC-001	001
variant 13 of MKG Morse taper	MKG-13
version of MKG Morse taper with attachment thread and with axial and radial coolant entry	
71EF1E8A38E35-001	001
variant 20 of MKG Morse taper	MKG-20
version of MKG Morse taper with tenon but without coolant supply	
71EF1E8E2EE7E-001	001
variant 21 of MKG Morse taper	MKG-21
version of MKG Morse taper with tenon and with axial coolant entry	
71EF1E8E4A3B4-001	001
variant 22 of MKG Morse taper	MKG-22
version of MKG Morse taper with tenon and with radial coolant entry	
71EF1E8E797B3-001	001
variant 23 of MKG Morse taper	MKG-23
version of MKG Morse taper with tenon and with axial and radial coolant entry	
71EF1E8E931E0-001	001
variant 30 of MKG Morse taper	MKG-30
version of MKG Morse taper with tenon and hold back key but without coolant supply	
71EF1E8EADB27-001	001
variant 31 of MKG Morse taper	MKG-31
version of MKG Morse taper with tenon and hold back key and with axial coolant entry	
71EF1E8ECB31A-001	001
variant 32 of MKG morse taper	MKG-32
version of MKG Morse taper with tenon and hold back key and with radial coolant entry	
71EF1E8EF27D8-001	001
variant 33 of MKG Morse taper	MKG-33
version of MKG Morse taper with tenon and hold back key and with axial and radial coolant entry	
71EF1E8F157CF-001	001
variant 40 of MKG Morse taper	MKG-40

version of MKG Morse taper with attachment thread and positive drive but without coolant supply

71EF1E8F42243-001 **001**
variant 41 of MKG Morse taper **MKG-41**

version of MKG Morse taper with attachment thread and positive drive and with axial coolant entry

71EF1E8F6F981-001 **001**
variant 42 of MKG Morse taper **MKG-42**

version of MKG Morse taper with attachment thread and positive drive and with radial coolant entry

71EF1E8F8B318-001 **001**
variant 43 of MKG Morse taper **MKG-43**

version of MKG Morse taper with attachment thread and positive drive and with axial and radial coolant entry

71ED66AE75E58-001 **001**
MVS modular connection system Wohlhaupter **MVS**

connection between cylindrical mating surfaces with the connection located with a dowel on the machine side connector and with the workpiece side connector secured by a screw through the machine side connector

Subclasses:

71EF1E8FB6234-001 variant 01 of MVS modular connection system Wohlhaupter

Illustration reference: [Figure E.45](#)

71EF1E8FB6234-001 **001**
variant 01 of MVS modular connection system Wohlhaupter **MVS-01**

normal version of the MVS modular connection system Wohlhaupter

71ED66B9F6D76-001 **001**
NCT Novex-NC-Tools Walter **NCT**

connection between conical mating surfaces with projecting lugs on the machine side connector that locate with slots in the workpiece side connector

Subclasses:

71EF1E8FFD738-001 variant 01 of NCT Novex-NC-Tools Walter

Illustration reference: [Figure E.46](#)

71EF1E8FFD738-001 **001**
variant 01 of NCT Novex-NC-Tools Walter **NCT-01**

normal version of NCT Novex-NC-Tools Walter

71EF1E9030508-001 **001**
PMC prismatic connection Coromant **PMC**

connection between specially profiled mating surfaces conforming to the dimensions of Sandvik Coromant design 470

Subclasses:

71EF1E906A58B-001 variant 01 of PMC prismatic connection Coromant

71EF1E9082FF5-001 variant 02 of PMC prismatic connection Coromant

71EF1E90F24F5-001 variant 04 of PMC prismatic connection Coromant

71EF1E91159E3-001 variant 07 of PMC prismatic connection Coromant

Illustration reference: [Figure E.47](#)

71EF1E906A58B-001 **001**
variant 01 of PMC prismatic connection Coromant **PMC-01**

version of PMC prismatic connection Coromant to mount a cut-off blade

71EF1E9082FF5-001 **001**
variant 02 of PMC prismatic connection Coromant **PMC-02**

version of PMC prismatic connection Coromant to make a connection between a cutting head and a boring bar located and clamped by a lever

71EF1E90F24F5-001 **001**
variant 04 of PMC prismatic connection Coromant **PMC-04**

version of PMC prismatic connection Coromant to make a connection between a clamping unit and a tool post or turret disk held in place by an adjustable wedge

71EF1E91159E3-001 **001**
variant 07 of PMC prismatic connection Coromant **PMC-07**

version of PMC prismatic connection Coromant that is Capto screw mounted

71ED66B1DF8E1-001 **001**
PMD prismatic connection standard **PMD**

connection between mating surfaces with a specific dovetail profile

Subclasses:

71EF1E915B0BD-001 variant 01 of PMD prismatic connection standard

Illustration reference: [Figure E.48](#)

71EF1E915B0BD-001 **001**
variant 01 of PMD prismatic connection standard **PMD-01**

normal version of PMD prismatic connection standard

726F560E00E29-001 **003**
PMI prismatic connection Iscar **PMI**

connection between prismatic mating surfaces of specific detailed design conforming to the dimensions of an ISCAR prismatic connection

Subclasses:

726F560E46BC2-001 variant 01 of PMI prismatic connection Iscar

726F560E46BC2-001 003

variant 01 of PMI prismatic connection Iscar PMI01

version of PMI prismatic connection ISCAR to hold a cut-off support blade “tool block”

71ED66B5E2C68-001 001

PMK prismatic connection Kennametal PMK

connection between prismatic mating surfaces of specific detailed design conforming to the dimensions of a Kennametal prismatic connection

Subclasses:

71EF1E918967F-001 variant 01 of PMK prismatic connection Kennametal

Illustration reference: [Figure E.49](#)

71EF1E918967F-001 001

variant 01 of PMK prismatic connection Kennametal PMK-01

version of PMK prismatic connection Kennametal to hold a cut-off support blade A1-A3

71EF1E91D5D4F-001 001

PMS prismatic connection SECO PMS

connection between prismatic mating surfaces with detailed specific design conforming to the dimensions of SECO SPB

Subclasses:

71EF1E91EFA2F-001 variant 01 of PMS prismatic connection SECO

71EF1E91EFA2F-001 001

variant 01 of PMS prismatic connection SECO PMS-01

normal version of PMS prismatic connection SECO

71ED66ADD852B-001 001

RFX Rotaflex system Widia RFX

connection between stepped cylindrical mating surfaces conforming to the dimensions of the Widia Rotaflex system

Subclasses:

71EF2242723DD-001 variant 01 of RFX Rotaflex system Widia

Illustration reference: [Figure E.50](#)

71EF2242723DD-001 001

variant 01 of RFX Rotaflex system Widia RFX-01

normal version of RFX Rotaflex system Widia

71EF2242B4D39-001 **001**

SAC screw connection Coromant **SAC**

connection formed by a screwed-in thread

Subclasses:

71EF22434D3F1-001 variant 01 of SAC screw connection Coromant

71EF2243668E1-001 variant 02 of SAC screw connection Coromant

71EF224379DA9-001 variant 03 of SAC screw connection Coromant

Illustration reference: [Figure E.51](#)

71EF22434D3F1-001 **001**

variant 01 of SAC screw connection Coromant **SAC-01**

version of SAC screw connection Coromant with a four-start square thread between a drilling head and a drilling tube in deep hole drilling with an second inner tube

71EF2243668E1-001 **001**

variant 02 of SAC screw connection Coromant **SAC-02**

version of SAC screw connection Coromant with a four-start square thread between a drilling head and a single drilling tube in deep hole drilling

71EF224379DA9-001 **001**

variant 03 of SAC screw connection Coromant **SAC-03**

version of SAC screw connection Coromant to provide a threaded connector for end-mills

726F560E9DD9B-001 **003**

SAI screw connection ISCAR **SAI**

connection formed by a specific screwed-in thread

Subclasses:

726F560EE02D1-001 variant 01 of SAI screw connection Iscar

726F560F2A767-001 variant 02 of SAI screw connection Iscar

726F560EE02D1-001 **003**

variant 01 of SAI screw connection Iscar **SAI 01**

version of SAI screw connection ISCAR with a specific thread between an end mill head and an adaptive item

726F560F2A767-001 **003**

variant 02 of SAI screw connection Iscar **SAI 02**

version of SAI screw connection ISCAR with a ISO-metric thread between an end mill head and an adaptive item

71EF2242CDE99-001 **001**

SBA SBA-system Komet **SBA**

connection of a profiled cylindrical mating surface on the workpiece side secured by a locking pin in the machine side connector

Subclasses:

71EF224394D8C-001 variant 01 of SBA SBA-system Komet

Illustration reference: [Figure E.52](#)

71EF224394D8C-001 **001**
variant 01 of SBA SBA-system Komet **SBA-01**

normal version of SBA SBA-system Komet

71EF2242E8099-001 **001**

SCA SECO cartridge mounting **SCA**

connection for the mounting of a cartridge

Subclasses:

71EF2243AFA09-001 variant 01 of SCA SECO cartridge mounting

71EF2243CB404-001 variant 02 of SCA SECO cartridge mounting

71EF2243E36FF-001 variant 03 of SCA SECO cartridge mounting

Illustration reference: [Figure E.53](#)

71EF2243AFA09-001 **001**
variant 01 of SCA SECO cartridge mounting **SCA-01**

version of SCA SECO cartridge mounting with rectangular mating surfaces

71EF2243CB404-001 **001**

variant 02 of SCA SECO cartridge mounting **SCA-02**

version of SCA SECO cartridge mounting with serrated mating surfaces

71EF2243E36FF-001 **001**

variant 03 of SCA SECO cartridge mounting **SCA-03**

version of SCA SECO cartridge mounting conforming to the dimensions of SECO system 230.19

71EF224302CF7-001 **001**

SCR SECO crownlock connection **SCR**

connection between two mating surfaces with serrations in two directions at right angles

Subclasses:

71EF2247CCF24-001 variant 01 of SCR SECO crownlock connection

Illustration reference: [Figure E.54](#)

71EF2247CCF24-001 **001**
variant 01 of SCR SECO crownlock connection **SCR-01**

normal version of SCR SECO crownlock connection

71ED66BA0F1F7-001

001

SKG Steep taper

SKG

connection between conical mating surfaces with a cylindrical extension of the end sections

Subclasses:

71EF224817F39-001 variant 10 of SKG Steep taper

71EF2248594F2-001 variant 11 of SKG Steep taper

71EF2248775E3-001 variant 16 of SKG Steep taper

71EF22489E8A3-001 variant 17 of SKG Steep taper

71EF2248B8EAB-001 variant 20 of SKG Steep taper

71EF2248CF17E-001 variant 21 of SKG Steep taper

71EF2248DA3F5-001 variant 26 of SKG Steep taper

71EF22490384F-001 variant 27 of SKG Steep taper

71EF22492256B-001 variant 30 of SKG Steep taper

71EF224948944-001 variant 31 of SKG Steep taper

71EF2249532BC-001 variant 36 of SKG Steep taper

71EF224979825-001 variant 37 of SKG Steep taper

71EF224996880-001 variant 40 of SKG Steep taper

71EF2249B2AF9-001 variant 41 of SKG Steep taper

71EF2249D9BD8-001 variant 46 of SKG Steep taper

71EF224A0E1FD-001 variant 47 of SKG Steep taper

71EF224A4275A-001 variant 50 of SKG Steep taper

71EF224A59B6E-001 variant 51 of SKG Steep taper

71EF224A70519-001 variant 56 of SKG Steep taper

71EF224A8BA27-001 variant 57 of SKG Steep taper

Illustration reference: [Figure E.55](#)

71EF224817F39-001

001

variant 10 of SKG Steep taper

SKG-10

version of SKG Steep taper conforming to the dimensions of DIN 69871 form A without coolant supply

71EF2248594F2-001

001

variant 11 of SKG Steep taper

SKG-11

version of SKG Steep taper conforming to the dimensions of DIN 68971 form AD with central coolant entry

71EF2248775E3-001

001

variant 16 of SKG Steep taper

SKG-16

version of SKG Steep taper conforming to the dimensions of DIN 69871 form B with decentral coolant entry on the collar

71EF22489E8A3-001 **001**

variant 17 of SKG Steep taper **SKG-17**

version of SKG Steep taper conforming to the dimensions of DIN 69871 form AD/B with central and decentral coolant entry

71EF2248B8EAB-001 **001**

variant 20 of SKG Steep taper **SKG-20**

version of SKG Steep taper conforming to the dimensions of DIN 2080 without coolant supply

71EF2248CF17E-001 **001**

variant 21 of SKG Steep taper **SKG-21**

version of SKG Steep taper conforming to the dimensions of DIN 2080 with central coolant entry

71EF2248DA3F5-001 **001**

variant 26 of SKG Steep taper **SKG-26**

version of SKG Steep taper conforming to the dimensions of DIN 2080 with decentral coolant entry on the collar

71EF22490384F-001 **001**

variant 27 of SKG Steep taper **SKG-27**

version of SKG Steep taper conforming to the dimensions of DIN 2080 with central and decentral coolant entry on the collar

71EF22492256B-001 **001**

variant 30 of SKG Steep taper **SKG-30**

version of SKG Steep taper conforming to the dimensions of ANSI Caterpillar inch retention knob thread without coolant supply

71EF224948944-001 **001**

variant 31 of SKG Steep taper **SKG-31**

version of SKG Steep taper conforming to the dimensions of ANSI Caterpillar inch retention knob thread with central coolant entry

71EF2249532BC-001 **001**

variant 36 of SKG Steep taper **SKG-36**

version of SKG Steep taper conforming to the dimensions of ANSI Caterpillar inch retention knob thread with decentral coolant entry on the collar

71EF224979825-001 **001**

variant 37 of SKG Steep taper **SKG-37**

version of SKG Steep taper conforming to the dimensions of ANSI Caterpillar inch retention knob thread with central and decentral coolant entry

71EF224996880-001 **001**

variant 40 of SKG Steep taper	SKG-40
version of SKG Steep taper conforming to the dimensions of ANSI Caterpillar metric retention knob thread without coolant supply	
71EF2249B2AF9-001	001
variant 41 of SKG Steep taper	SKG-41
version of SKG Steep taper conforming to the dimensions of ANSI Caterpillar metric retention knob thread with central coolant entry	
71EF2249D9BD8-001	001
variant 46 of SKG Steep taper	SKG-46
version of SKG Steep taper conforming to the dimensions of ANSI Caterpillar metric retention knob thread with decentral coolant entry	
71EF224A0E1FD-001	001
variant 47 of SKG Steep taper	SKG-47
version of SKG Steep taper conforming to the dimensions of ANSI Caterpillar metric retention knob thread with central and decentral coolant entry	
71EF224A4275A-001	001
variant 50 of SKG Steep taper	SKG-50
version of SKG Steep taper conforming to the dimensions of MAS BT without central coolant supply	
71EF224A59B6E-001	001
variant 51 of SKG Steep taper	SKG-51
version of SKG Steep taper conforming to the dimensions of MAS BT with central coolant entry	
71EF224A70519-001	001
variant 56 of SKG Steep taper	SKG-56
version of SKG Steep taper conforming to the dimensions of MAS BT with decentral coolant entry on the collar	
71EF224A8BA27-001	001
variant 57 of SKG Steep taper	SKG-57
version of SKG Steep taper conforming to the dimensions of MAS BT with central and decentral coolant entry	
71EF224AAA436-001	001
SMM SECO minimaster	SMM
connection between conical mating surfaces with a locking profile of specific design at the narrow end	
Subclasses:	
71EF224ADA70A-001 variant 01 of SMM SECO minimaster	
Illustration reference:	Figure E.56
71EF224ADA70A-001	001

variant 01 of SMM SECO minimaster **SMM-01**

normal version of SMM SECO minimaster

71EF224ABDBD9-001 **001**

SMS SECO modular serrated connection **SMS**

connection between serrated mating surfaces secured by screws and conforming to the dimensions of SECO SV21

Subclasses:

71EF224AEF279-001 variant 01 of SMS SECO modular serrated connection

Illustration reference: [Figure E.57](#)

71EF224AEF279-001 **001**

variant 01 of SMS SECO modular serrated connection **SMS-01**

normal version of SMS SECO modular serrated connection

71ED66ADFAA9B-001 **001**

SPK holding arbor **SPK**

connection between cylindrical mating surfaces with specific detailed design

Subclasses:

71EF25FA05521-001 variant 01 of SPK holding arbor

71EF25FA3739C-001 variant 02 of SPK holding arbor

71EF25FA830B8-001 variant 03 of SPK holding arbor

71EF25FAAB512-001 variant 04 of SPK holding arbor

71EF25FADB60F-001 variant 05 of SPK holding arbor

71EF25FAF655C-001 variant 06 of SPK holding arbor

71EF25FB14928-001 variant 07 of SPK holding arbor

71EF25FB3DCEC-001 variant 08 of SPK holding arbor

71EF25FB6D150-001 variant 09 of SPK holding arbor

71EF25FB8DE89-001 variant 10 of SPK holding arbor

71EF25FBB4F22-001 variant 11 of SPK holding arbor

71EF25FC1BBDA-001 variant 12 of SPK holding arbor

Illustration reference: [Figure E.58](#)

71EF25FA05521-001 **001**

variant 01 of SPK holding arbor **SPK-01**

version of SPK holding arbor with a bolt hole circle diameter 66,7 mm

NOTE Equivalent to holding arbor size 40.

71EF25FA3739C-001 **001**

variant 02 of SPK holding arbor	SPK-02
version of SPK holding arbor with a bolt hole circle diameter 101,6 mm	
NOTE Equivalent to holding arbor size 50.	
71EF25FA830B8-001	001
variant 03 of SPK holding arbor	SPK-03
version of SPK holding arbor with a bolt hole circle diameter 177,8 mm	
NOTE Equivalent to holding arbor size 60.	
71EF25FAAB512-001	001
variant 04 of SPK holding arbor	SPK-04
version of SPK holding arbor with bolt hole circles of diameters 66,7mm and 177,8 mm	
71EF25FADB60F-001	001
variant 05 of SPK holding arbor	SPK-05
version of SPK holding arbor with bolt hole circles of diameters 101,6 mm and 177,8 mm	
71EF25FAF655C-001	001
variant 06 of SPK holding arbor	SPK-06
version of SPK holding arbor with a bolt hole circle diameter 54 mm	
NOTE Equivalent to holding arbor size 30.	
71EF25FB14928-001	001
variant 07 of SPK holding arbor	SPK-07
version of SPK holding arbor with a bolt hole circle diameter 80 mm	
NOTE Equivalent to holding arbor size 45.	
71EF25FB3DCEC-001	001
variant 08 of SPK holding arbor	SPK-08
version of SPK holding arbor with a bolt hole circle diameter 120,6 mm	
NOTE Equivalent to holding arbor size 55.	
71EF25FB6D150-001	001
variant 09 of SPK holding arbor	SPK-09
version of SPK holding arbor with a bolt hole circle diameter 220 mm	
NOTE Equivalent to holding arbor size 65.	
71EF25FB8DE89-001	001
variant 10 of SPK holding arbor	SPK-10
version of SPK holding arbor with a bolt hole circle diameter 265 mm	
NOTE Equivalent to holding arbor size 70.	

71EF25FBB4F22-001 **001**

variant 11 of SPK holding arbor **SPK-11**

version of SPK holding arbor with a bolt hole circle diameter 315 mm

NOTE Equivalent to holding arbor size 75.

71EF25FC1BBDA-001 **001**

variant 12 of SPK holding arbor **SPK-12**

version of SPK holding arbor with a bolt hole circle diameter 400 mm

NOTE Equivalent to holding arbor size 80.

71EF25FC490BF-001 **001**

SRT SECO R2 shank **SRT**

connection with a profiled prismatic male surface on the workpiece side connector and secured by screws through the machine side connector and conforming to the dimensions of the SECO R2 design

Subclasses:

71EF25FC62677-001 variant 01 of SRT SECO R2 shank

Illustration reference: [Figure E.59](#)

71EF25FC62677-001 **001**

variant 01 of SRT SECO R2 shank **SRT-01**

normal version of SRT SECO R2 shank

71ED66AE29B8D-001 **001**

STH automotive shank **STH**

connection between cylindrical mating surfaces with a Woodruff key on the workpiece side

Subclasses:

71EF25FCB20D6-001 variant 01 of STH automotive shank

Illustration reference: [Figure E.60](#)

71EF25FCB20D6-001 **001**

variant 01 of STH automotive shank **STH-01**

normal version of STH automotive shank

71ED66AE588FA-001 **001**

SWB quick change connection **SWB**

connection with profiled cylindrical surfaces that can easily be separated

Subclasses:

71F8F4AAB6B82-001 variant 01 of SWB quick change connection

Illustration reference: [Figure E.61](#)

71F8F4AAB6B82-001 **001**

variant 01 of SWB quick change connection SWB-01

normal version of SWB quick change connection

71EF2955BD8F5-001 001

SZB collet shortened design Biax SZB

connection to a cylindrical mating surface by means of a slotted sleeve conforming to the dimensions of Biax type 7

Subclasses:

71F8F4ACA903C-001 variant 01 of SZB collet shortened design Biax

71F8F4ACA903C-001 001

variant 01 of SZB collet shortened design Biax SZB-01

normal version of SZB collet shortened design Biax

71EF2955D5933-001 001

SZC collet connection Coromant SZC

connection by means of a slotted sleeve that can be compressed onto a cylindrical mating surface

Subclasses:

71F8F4AD0700A-001 variant 01 of SZC collet connection Coromant

71F8F4AD0A9D3-001 variant 02 of SZC collet connection Coromant

71F8F4AD0700A-001 001

variant 01 of SZC collet connection Coromant SZC-01

version of SZC collet connection Coromant called Hydrogrip where the compression is applied by hydraulic force actuated and maintained in use by a screw

NOTE Hydrogrip is a registered trade mark of AB Sandvik Coromant.

Illustration reference: [Figure E.62](#)

71F8F4AD0A9D3-001 001

variant 02 of SZC collet connection Coromant SZC-02

version of SZC collet connection Coromant called Corogrip that uses hydraulic compression to activate and release a self-locking mechanism to hold the tool

NOTE Corogrip is a registered trade mark of AB Sandvik Coromant.

Illustration reference: [Figure E.63](#)

71ED66BA26E2E-001 001

SZD collet connection standard SZD

connection by means of a slotted sleeve that can be compressed into a conical mating surface

Subclasses:

71F8F4ADCFB28-001 variant 01 of SZD collet connection standard

71F8F4ADDFD29-001 variant 02 of SZD collet connection standard
71F8F4ADE49F6-001 variant 03 of SZD collet connection standard
71F8F4ADE904D-001 variant 04 of SZD collet connection standard
71F8F4ADF72B3-001 variant 11 of SZD collet connection standard
71F8F4ADFB413-001 variant 12 of SZD collet connection standard
71F8F4ADFFFF9-001 variant 13 of SZD collet connection standard

Illustration reference: [Figure E.64](#)

71F8F4ADCFB28-001	001
variant 01 of SZD collet connection standard	SZD-01
version of SZD collet connection standard with 1:10 taper	
71F8F4ADDFD29-001	001
variant 02 of SZD collet connection standard	SZD-02
version of SZD collet connection standard with 8° taper	
71F8F4ADE49F6-001	001
variant 03 of SZD collet connection standard	SZD-03
version of SZD collet connection standard with draw-in collets with 40° taper	
71F8F4ADE904D-001	001
variant 04 of SZD collet connection standard	SZD-04
version of SZD collet connection standard of dead length type with 30° taper	
71F8F4ADF72B3-001	001
variant 11 of SZD collet connection standard	SZD-11
version of SZD collet connection standard with 26° taper	
71F8F4ADFB413-001	001
variant 12 of SZD collet connection standard	SZD-12
version of SZD collet connection standard with 40° taper	
71F8F4ADFFFF9-001	001
variant 13 of SZD collet connection standard	SZD-13
version of SZD collet connection standard with 45° taper	
71EF2955F7771-001	001
SZE collet connection Erikson	SZE
connection by means of a slotted sleeve that can be compressed onto a conical mating surface with dimensions specified by Erikson	

Subclasses:

71F8F4AEABB7A-001 variant 03 of SZE collet connection Erikson

71F8F4AEBB269-001 variant 04 of SZE collet connection Erikson

Illustration reference: [Figure E.65](#)

71F8F4AEABB7A-001 001

variant 03 of SZE collet connection Erikson SZE-03

version of SZE collet connection Erikson with dimensions conforming to the DF design

71F8F4AEBB269-001 001

variant 04 of SZE collet connection Erikson SZE-04

version of SZE collet connection Erikson with dimensions conforming to the DK shortened design

71EF29560D5F6-001 001

SZP collet Eminent-Perman SZP

connection by means of a slotted sleeve that can be compressed on the mating surface with dimensions specified by Eminent-Perman

Subclasses:

71F8F4AFC5115-001 variant 01 of SZP collet Eminent-Perman

71F8F4AFC5115-001 001

variant 01 of SZP collet Eminent-Perman SZP-01

normal version of SZP collet Eminent-Perman

71EF2956256D4-001 001

SZR collet KSF Roehm SZR

connection by means of a slotted sleeve that can be compressed in the mating surface with dimensions specified by Roehm

Subclasses:

71F8F4B457636-001 variant 01 of SZR collet KSF Roehm

71F8F4B457636-001 001

variant 01 of SZR collet KSF Roehm SZR-01

version of SZR collet KSF Roehm conforming to the dimensions of KSF-16, KSF-25, and KSF-30

71EF29563BB7E-001 001

SZS collet Steinel Bohrmaster SZS

connection by means of a slotted sleeve that can be compressed on a conical mating surface with dimensions specified by Steinel Bohrmaster

Subclasses:

71F8F4B475442-001 variant 01 of SZS collet Steinel Bohrmaster

71F8F4B479EA2-001 variant 02 of SZS collet Steinel Bohrmaster

71F8F4B47DB96-001 variant 03 of SZS collet Steinel Bohrmaster

71F8F4B475442-001	001
variant 01 of SZS collet Steinel Bohrmaster	SZS-01
version of SZS collet Steinel Bohrmaster with 10° taper	
71F8F4B479EA2-001	001
variant 02 of SZS collet Steinel Bohrmaster	SZS-02
version of SZS collet Steinel Bohrmaster with 15° taper	
71F8F4B47DB96-001	001
variant 03 of SZS collet Steinel Bohrmaster	SZS-03
version of SZS collet Steinel Bohrmaster with 20° taper	
71EF2956584ED-001	001
URM Urma connection	URM
connection between cylindrical mating surfaces with different diameters	

Subclasses:

71F8F4B4A6D29-001 variant 01 of URM Urma connection

Illustration reference: [Figure E.66](#)

71F8F4B4A6D29-001	001
variant 01 of URM Urma connection	URM-01
normal version of URM Urma connection	

71EF29566E0D4-001	001
UTS UTS Widia	UTS

connection between stepped conical mating surfaces

Subclasses:

71F8F4B4C5B9A-001 variant 01 of UTS UTS Widia

Illustration reference: [Figure E.67](#)

71F8F4B4C5B9A-001	001
variant 01 of UTS UTS Widia	UTS-01
normal version of UTS UTS Widia	

71ED66AEA108B-001	001
VAS Variant System Coromant	VAS

connection of generally cylindrical form with a bayonet connection secured by a nut

NOTE Variant System is a registered trade mark of AB Sandvik Coromant.

Subclasses:

71F8F4B4DF852-001 variant 01 of VAS Variant System Coromant

Illustration reference: [Figure E.68](#)

71F8F4B4DF852-001 **001**
variant 01 of VAS Variant System Coromant **VAS-01**

normal version of VAS Variant System Coromant

71ED66B5FAE04-001 **001**

VKT rectangular connection **VKT**

connection between rectangular cross section mating surfaces

NOTE The definition includes the square cross section form.

Subclasses:

71F8F4B51A785-001 variant 01 of VKT rectangular connection

Illustration reference: [Figure E.69](#)

71F8F4B51A785-001 **001**
variant 01 of VKT rectangular connection **VKT-01**

normal version of VKT rectangular connection

71ED66AEBC779-001 **001**

VLS Varilock System Coromant **VLS**

connection of generally cylindrical form with a centering device formed by a boss with two diameters

NOTE Varilock System is a registered trade mark of AB Sandvik Coromant.

Subclasses:

71F8F4B4F1367-001 variant 01 of VLS Varilock System Coromant

Illustration reference: [Figure E.70](#)

71F8F4B4F1367-001 **001**
variant 01 of VLS Varilock System Coromant **VLS-01**

normal version of VLS Varilock System Coromant

71ED66AF2175B-001 **001**

ZYL cylindrical shank connection **ZYL**

connection to a cylindrical mating surface by either a jaw chuck or a screw clamp

Subclasses:

71F8F4B5348DB-001 variant 01 of ZYL cylindrical shank connection

71F8F4B5390AF-001 variant 03 of ZYL cylindrical shank connection

71F8F4B53E3D2-001 variant 04 of ZYL cylindrical shank connection

71F8F4B54FA0D-001 variant 10 of ZYL cylindrical shank connection

71F8F4B554639-001 variant 11 of ZYL cylindrical shank connection

71F8F4B56465A-001 variant 13 of ZYL cylindrical shank connection
71F8F4B56A63D-001 variant 14 of ZYL cylindrical shank connection
71F8F4B56FE57-001 variant 15 of ZYL cylindrical shank connection
71F8F4B57F583-001 variant 16 of ZYL cylindrical shank connection
71F8F4B5853C1-001 variant 17 of ZYL cylindrical shank connection
71F8F4B58A106-001 variant 18 of ZYL cylindrical shank connection
71F8F4B597D0B-001 variant 19 of ZYL cylindrical shank connection
71F8F4B5ACE12-001 variant 20 of ZYL cylindrical shank connection
71F8F4B5B212B-001 variant 21 of ZYL cylindrical shank connection
71F8F4B5B7D42-001 variant 22 of ZYL cylindrical shank connection
71F8F4B5C5EC2-001 variant 23 of ZYL cylindrical shank connection
71F8F4B5D1A6B-001 variant 24 of ZYL cylindrical shank connection
71F8F4B82CEDE-001 variant 50 of ZYL cylindrical shank connection
71F8F4B832F8A-001 variant 53 of ZYL cylindrical shank connection

Illustration reference: [Figure E.71](#)

71F8F4B5348DB-001 001

variant 01 of ZYL cylindrical shank connection ZYL-01

version of ZYL cylindrical shank connection to a straight shank without any clamping features

71F8F4B5390AF-001 001

variant 03 of ZYL cylindrical shank connection ZYL-03

version of ZYL cylindrical shank connection with attachment thread without planar contact surface

REMARKS Clarkson type

71F8F4B53E3D2-001 001

variant 04 of ZYL cylindrical shank connection ZYL-04

version of ZYL cylindrical shank connection with attachment thread with planar contact surface

REMARKS Clarkson type

71F8F4B54FA0D-001 001

variant 10 of ZYL cylindrical shank connection ZYL-10

version of ZYL cylindrical shank connection with plain clamping surface without planar contact surface

REMARKS Weldon type

71F8F4B554639-001 001

variant 11 of ZYL cylindrical shank connection ZYL-11

version of ZYL cylindrical shank connection with plain clamping surface without planar contact surface

REMARKS Drill shank type

71F8F4B56465A-001 **001**

variant 13 of ZYL cylindrical shank connection **ZYL-13**

version of ZYL cylindrical shank connection with 2° inclined clamping surface without planar contact surface

REMARKS Whistle Notch type

71F8F4B56A63D-001 **001**

variant 14 of ZYL cylindrical shank connection **ZYL-14**

version of ZYL cylindrical shank connection with plain and 2° inclined clamping surface without planar contact surface

REMARKS Combined Weldon/Whistle Notch type

71F8F4B56FE57-0010 **01**

variant 15 of ZYL cylindrical shank connection **ZYL-15**

version of ZYL cylindrical shank connection with 15° to 20° inclined clamping surface without planar contact surface

71F8F4B57F583-001 **001**

variant 16 of ZYL cylindrical shank connection **ZYL-16**

version of ZYL cylindrical shank connection with 2° inclined clamping surface with planar contact surface

71F8F4B5853C1-001 **001**

variant 17 of ZYL cylindrical shank connection **ZYL-17**

version of ZYL cylindrical shank connection with plain clamping surface and attachment thread without planar contact surface

REMARKS Combined Weldon/Clarkson type

71F8F4B58A106-001 **001**

variant 18 of ZYL cylindrical shank connection **ZYL-18**

version of ZYL cylindrical shank connection with plain and 2° inclined clamping surface with planar contact surface

REMARKS Combined Weldon/Whistle Notch type

71F8F4B597D0B-001 **001**

variant 19 of ZYL cylindrical shank connection **ZYL-19**

version of ZYL cylindrical shank connection with bayonet connection

71F8F4B5ACE12-001 **001**

variant 20 of ZYL cylindrical shank connection **ZYL-20**

version of ZYL cylindrical shank connection with tenon

71F8F4B5B212B-001 **001**

variant 21 of ZYL cylindrical shank connection	ZYL-21
version of ZYL cylindrical shank connection with driving squares	
71F8F4B5B7D42-001	001
variant 22 of ZYL cylindrical shank connection	ZYL-22
version of ZYL cylindrical shank connection for boring bars	
71F8F4B5C5EC2-001	001
variant 23 of ZYL cylindrical shank connection	ZYL-23
version of ZYL cylindrical shank connection with two plain clamping surfaces	
71F8F4B5D1A6B-001	001
variant 24 of ZYL cylindrical shank connection	ZYL-24
version of ZYL cylindrical shank connection with four plain clamping surfaces	
71F8F4B82CEDE-001	001
variant 50 of ZYL cylindrical shank connection	ZYL-50
version of ZYL cylindrical shank connection to a bf-drill shank	
71F8F4B832F8A-001	001
version of ZYL cylindrical shank connection with 2° inclined clamping surface with a cylindrical shank end without a planar contact surface	
REMARKS Whistle Notch type	
71ED66AF4BEFE-001	001
ZYV VDI shank	ZYV
connection between cylindrical mating surfaces with a location bore	
Subclasses:	
71F8F4B863718-001 variant 01 of ZYV VDI shank	
71F8F4B87213D-001 variant 02 of ZYV VDI shank	
71F8F4B863718-001	001
variant 01 of ZYV VDI shank	ZYV-01
version of ZYV VDI shank with a serrated section on the surface to provide location and holding	
71F8F4B87213D-001	001
variant 02 of ZYV VDI shank	ZYV-02
version of ZYV VDI shank without a serrated section on the surface	

Annex D (informative)

Connection interface feature property definitions

The layout of the entries in this annex is as follows:

BSU – version number	Revision number	Value format	
data type group	data type	unit identifier	
preferred name	short name	SYMBOL	synonymous name
definition			

source of definition

BSU of condition property = name of condition property

Source of code definition

NOTE

REMARKS

Illustration reference: Figure <Annex.figure number>

Visible class:

Applicable classes:

NOTE 1 An entry could not contain all the information specified.

NOTE 2 The value formats of properties are specified in ISO 13399-100.

71EBAF896BE9A-001 **001** **NR2 S.3.3**

REAL_MEASURE_TYPE mm

clamping length **lsc** LSC

dimension of the length of that portion of a tool item or an adaptive item that can participate in a connection

Visible class:

71CE7A72B6DA7-002 cutting tool library

Applicable classes:

71E01A0E9CBA9-001 boring bar

71DF8C37D9115-002 connection interface feature

71EAD3871D313-002 converter

71ED6E54B15C4-001 **001** **NR2 S.3.3**

REAL_MEASURE_TYPE mm

clamping length maximum **lscx** LSCX

greatest portion of the connection feature that is necessary to ensure the normal function of the tool item or the adaptive item

Visible class:

71CE7A72B6DA7-002 cutting tool library

Applicable classes:

71E01A0E9CBA9-001 boring bar

71DF8C37D9115-002 connection interface feature

71EAD3871D313-002 converter

71EBB339ED2BD-001 **001** **NR2 S.3.3**

LEVEL_TYPE mm

clamping length minimum lscn LSCN

smallest portion of the connection feature that is necessary to ensure that no damage is caused neither to the tool item nor to the adaptive item

Visible class:

71CE7A72B6DA7-002 cutting tool library

Applicable classes:

71E01A0E9CBA9-001 boring bar

71DF8C37D9115-002 connection interface feature

71EAD3871D313-002 converter

71EAC48CAD407-001 **001** **NR2 S..3.3**

REAL_MEASURE_TYPE mm

connection bore depth cbdp CBDP

depth of the hole in the centre of a tool or adaptive item used for making a connection

Visible class:

71CE7A72B6DA7-002 cutting tool library

Applicable classes:

71DF8C37D9115-002 connection interface feature

71EAD3871D313-002 converter

71E01A06BF88D-002 counterbore drill

71E01A06A8A08-002 countersink drill

71E0250E32A07-002 cylindrical broach

71E01A082DE72-001 disk broach

71EF07DFC283C-002 double half side mill

71EAD388173EE-001 driver

71EEBDADB63BE-002 extender

71E01A05B627B-002 face mill

71E01A05EA320-002 half side mill

71E01A04A8AEC-002 ream

71EAD385E51A0-002 reducer

71E0251F304E1-002 rotating borer

71E01A0540BE7-002 slab mill

71EF07E037025-002 slotting cutter

71D102AE3B252-001 **001** **X14**

STRING_TYPE

connection code machine side **ccms** **CCMS**

identifier for the capability to connect a component of a cutting tool to another component on the machine side

Visible class:

71CE7A72B6DA7-002 cutting tool library

Applicable classes:

71EAD37F18F34-002 adaptive item type

71EC61E726811-001 collet

71DF8C37D9115-002 connection interface feature

71E01A004C775-002 tool item type

71D102AE8A5A9-001 **001** **X14**

STRING_TYPE

connection code workpiece side **ccws** **CCWS**

identifier for the capability to connect a component to another component of a cutting tool on the workpiece side

Visible class:

71CE7A72B6DA7-002 cutting tool library

Applicable classes:

71EAD37F18F34-002 adaptive item type

71E01A04C377D-002 broach

71EC61E726811-001 collet

71DF8C37D9115-002 connection interface feature

71E01A00BD93C-002 drill

71E01A008D13F-002 mill

71E0251F304E1-002 rotating borer

71E01A05104CF-002 turn

71FC193318002-001 **001** **X17**

STRING_TYPE

connection size code czc **CZC**

identifier for the size of the connection between items of a cutting tool, excluding cutting items

Visible class:

71CE7A72B6DA7-002 cutting tool library

Applicable classes:

71EAD37F18F34-002 adaptive item type

71DF8C37D9115-002 connection interface feature

71E01A004C775-002 tool item type

71ED6E16D5978-001 **001** **X1**

NON_QUANTITATIVE_CODE_TYPE

connection unit basis cub **CUB**

label to identify the system of units in which the design of the connection is defined

Visible class:

71CE7A72B6DA7-002 cutting tool library

Applicable classes:

71EAD37F18F34-002 adaptive item type

71DF8C37D9115-002 connection interface feature

71E01A004C775-002 tool item type

71EBB342CC751-001 **001** **1**

BOOLEAN_TYPE

coolant supply property csp **CSP**

identification for whether a tool item or an adaptive item has a coolant supply

Visible class:

71CE7A72B6DA7-002 cutting tool library

Applicable classes:

71EAD37F18F34-002 adaptive item type

71DF8C37D9115-002 connection interface feature

71E01A004C775-002 tool item type

71EBBE32903BD-002 **001** **X17**

Annex E (informative)

Illustrations of connection systems

The diagrams on the following pages illustrate connection systems that are defined in [Annex C](#). The properties indicated in the diagrams are defined in ISO/TS 10303-4.

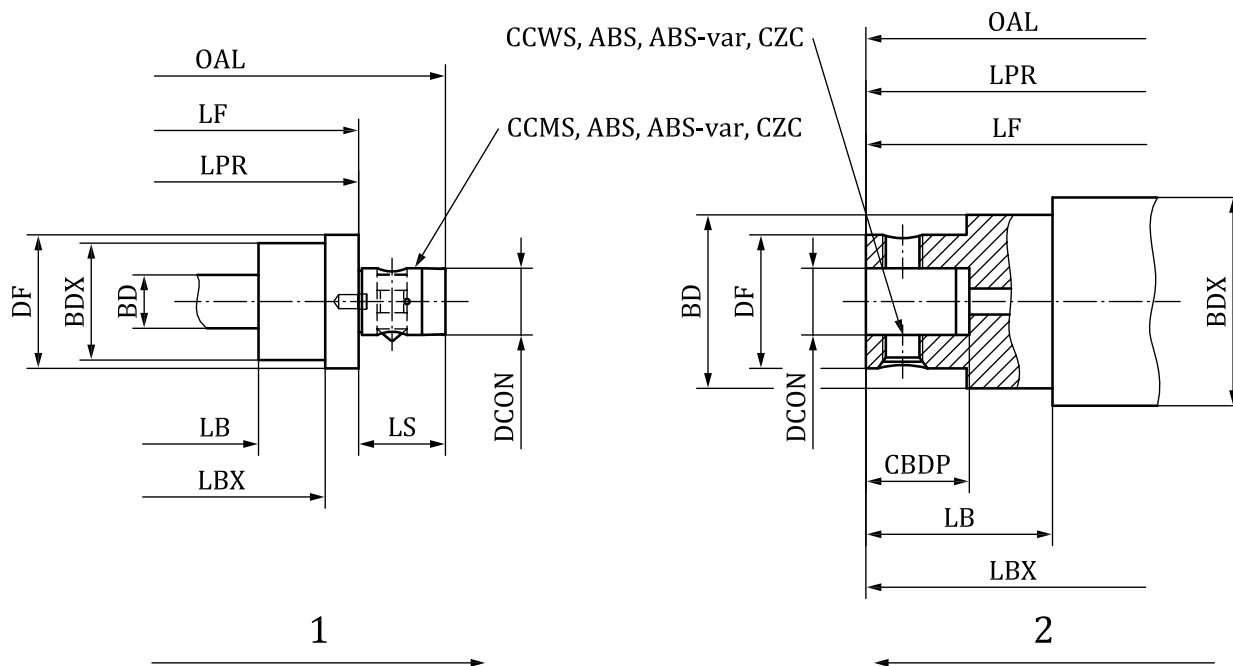

Key

- 1 machine side connection
- 2 workpiece side connection

Figure E.1 — ABS System Komet

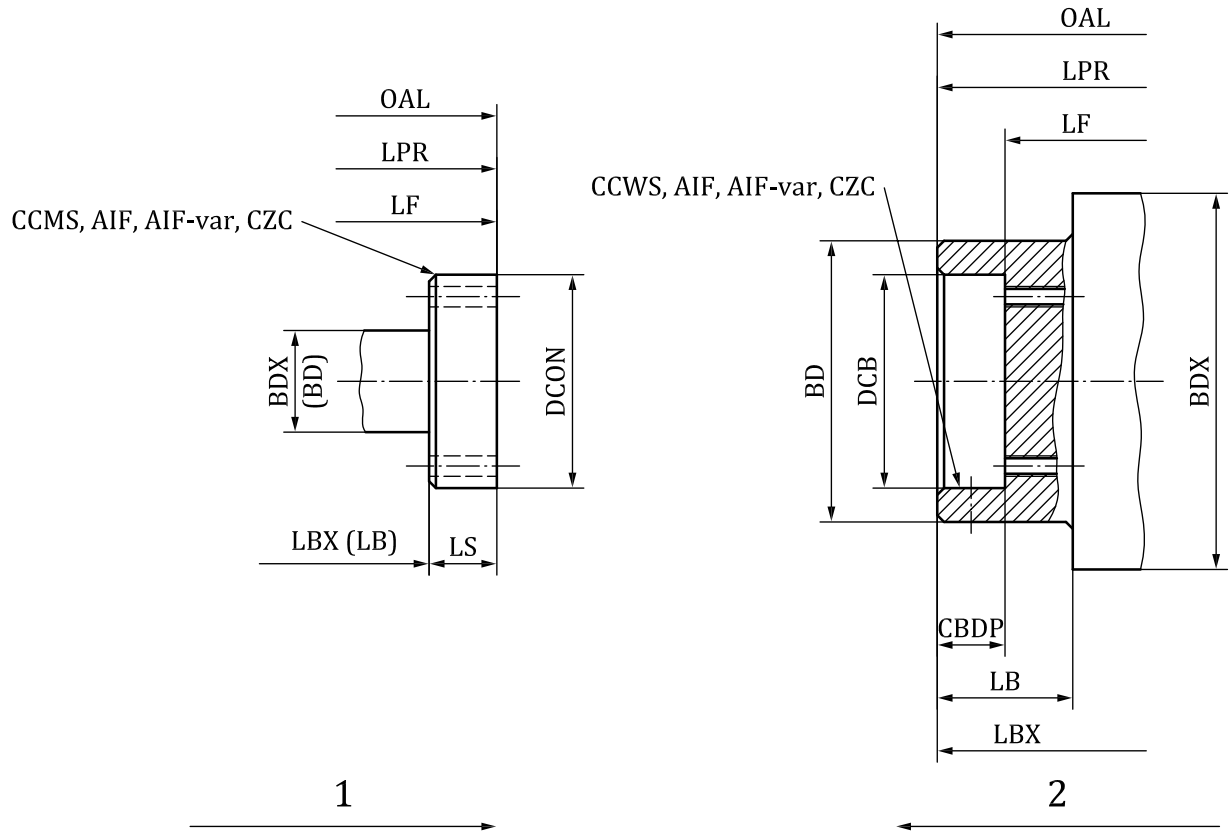

Key

- 1 machine side connection
- 2 workpiece side connection

Figure E.2 — AIF Adjustable Interface Dihart

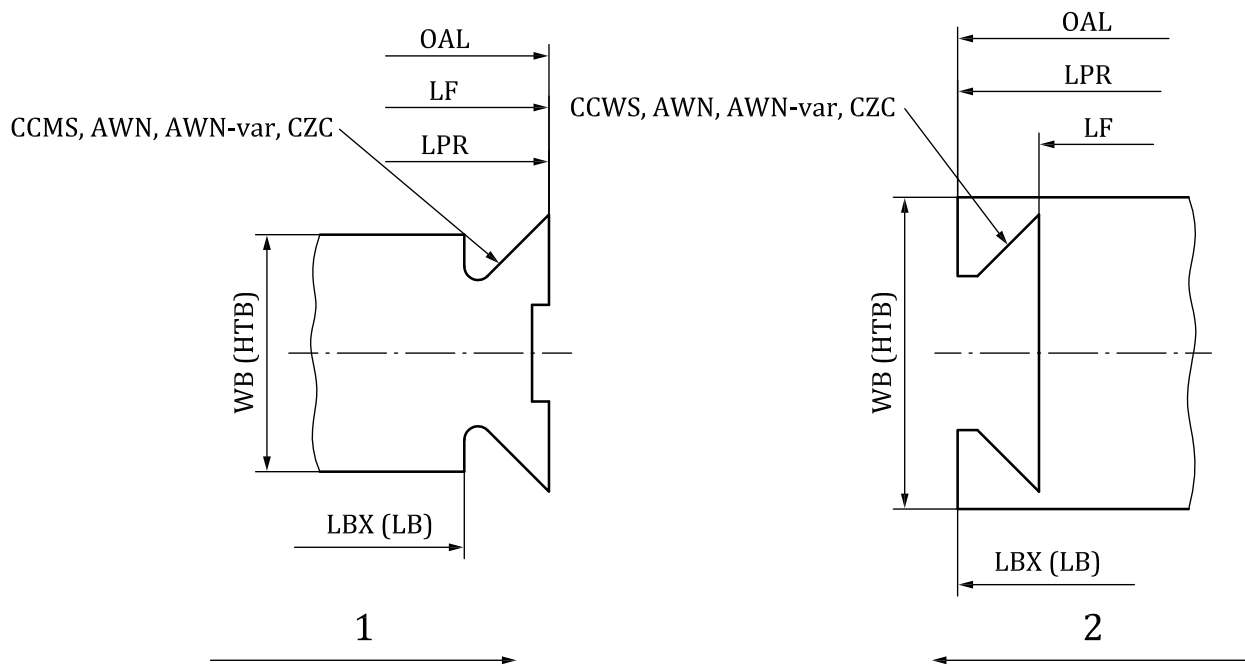

Key

- 1 machine side connection
- 2 workpiece side connection

Figure E.3 — AWN Prisma connection Schwanog

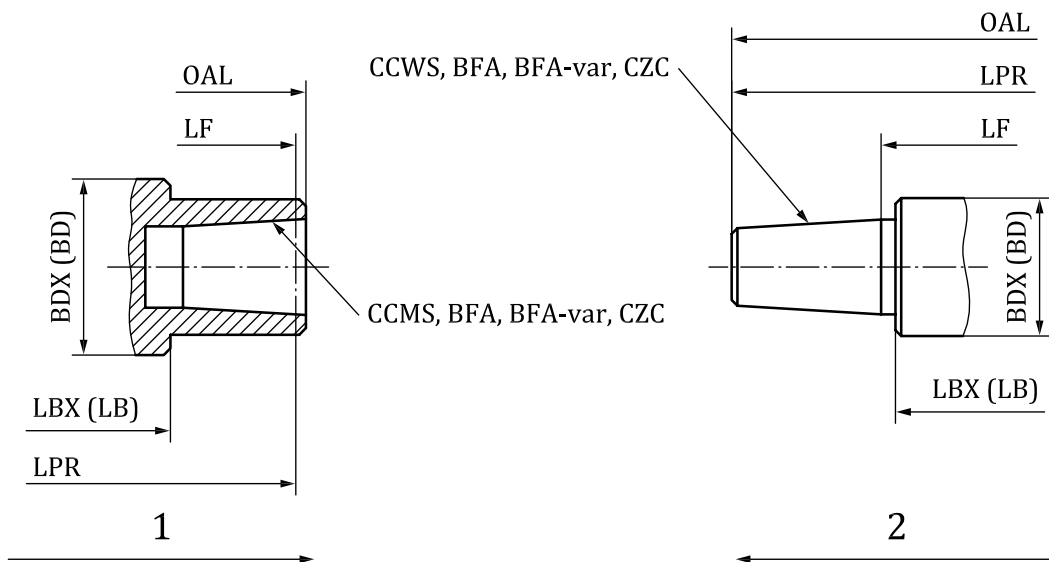

Key

- 1 machine side connection
- 2 workpiece side connection

Figure E.4 — BFA drill chuck connection

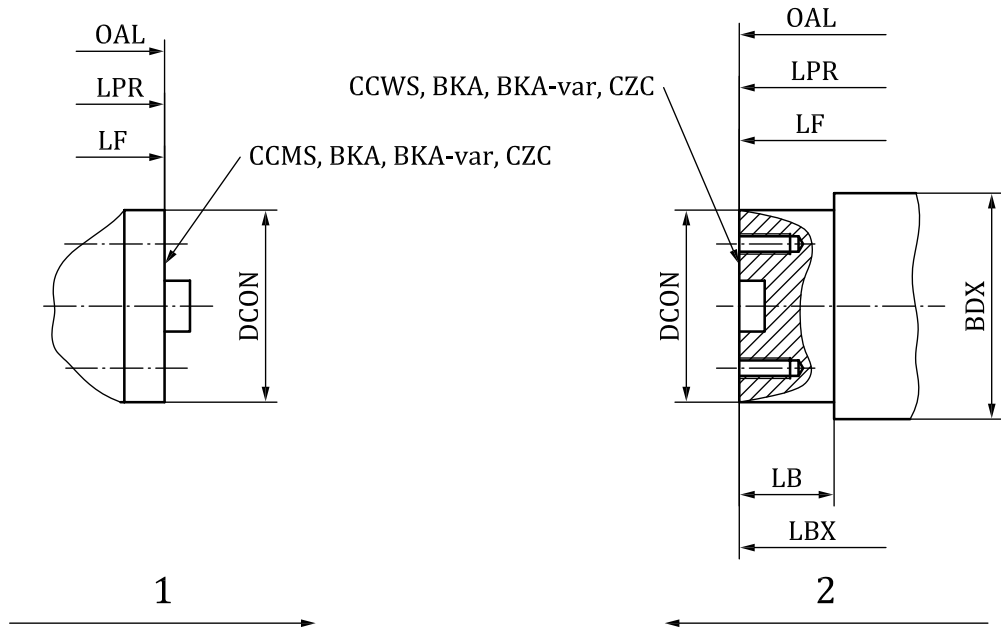

Key

- 1 machine side connection
- 2 workpiece side connection

Figure E.5 — BKA boring head connection

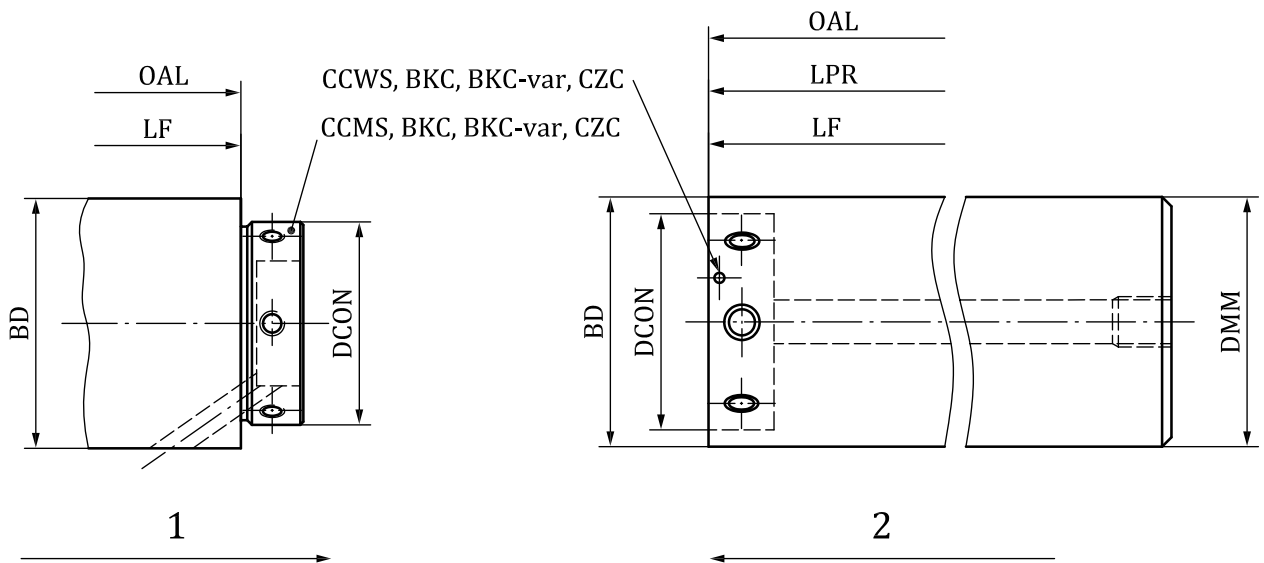

Key

- 1 machine side connection
- 2 workpiece side connection

Figure E.6 — BKC boring head connection Coromant

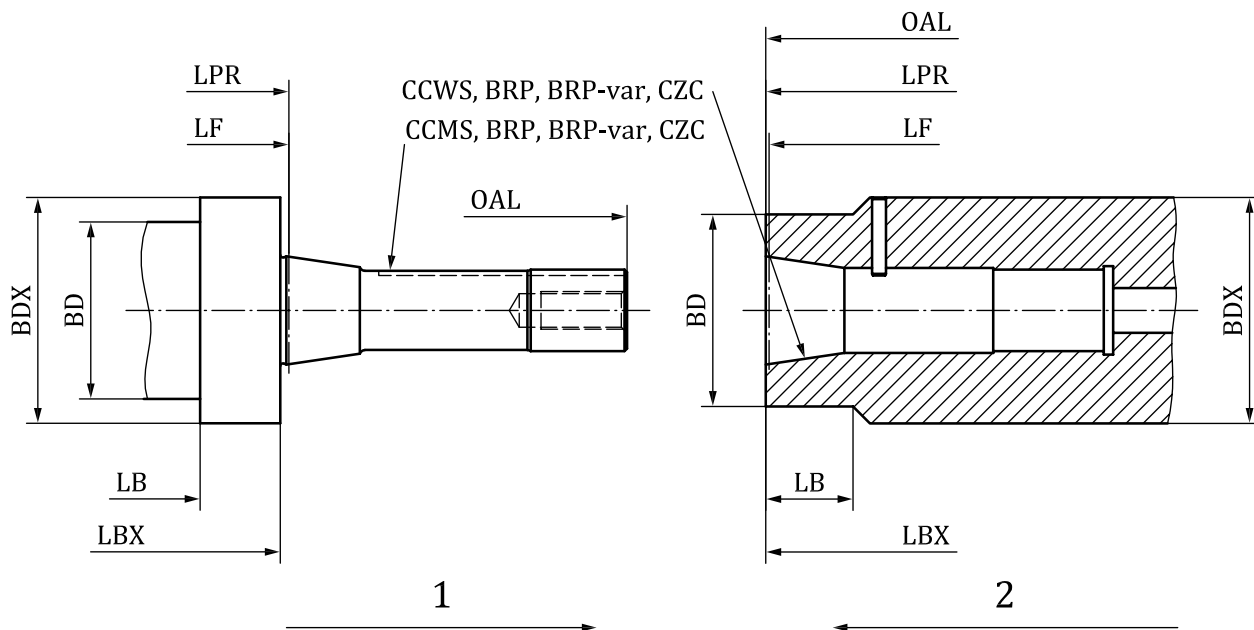

- Key**
- 1 machine side connection
 - 2 workpiece side connection

Figure E.7 — BRP Bridgeport connection

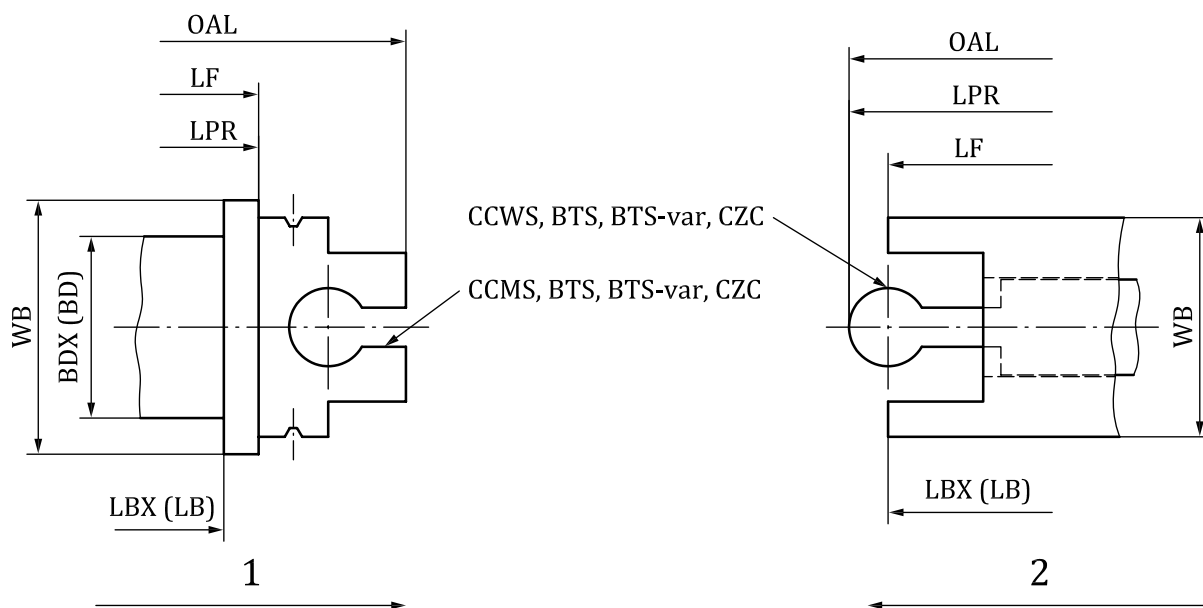

- Key**
- 1 machine side connection
 - 2 workpiece side connection

Figure E.8 — BTS Block Tool System Coromant

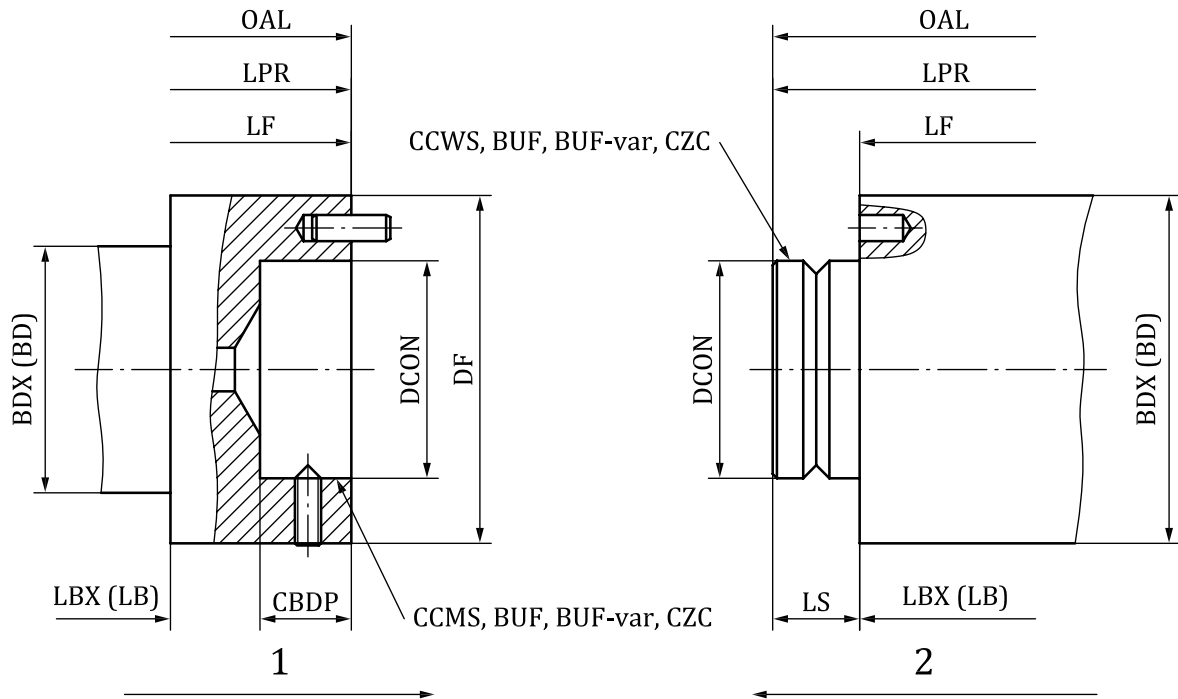

Key

- 1 machine side connection
- 2 workpiece side connection

Figure E.9 — BUF boring and chamfer system

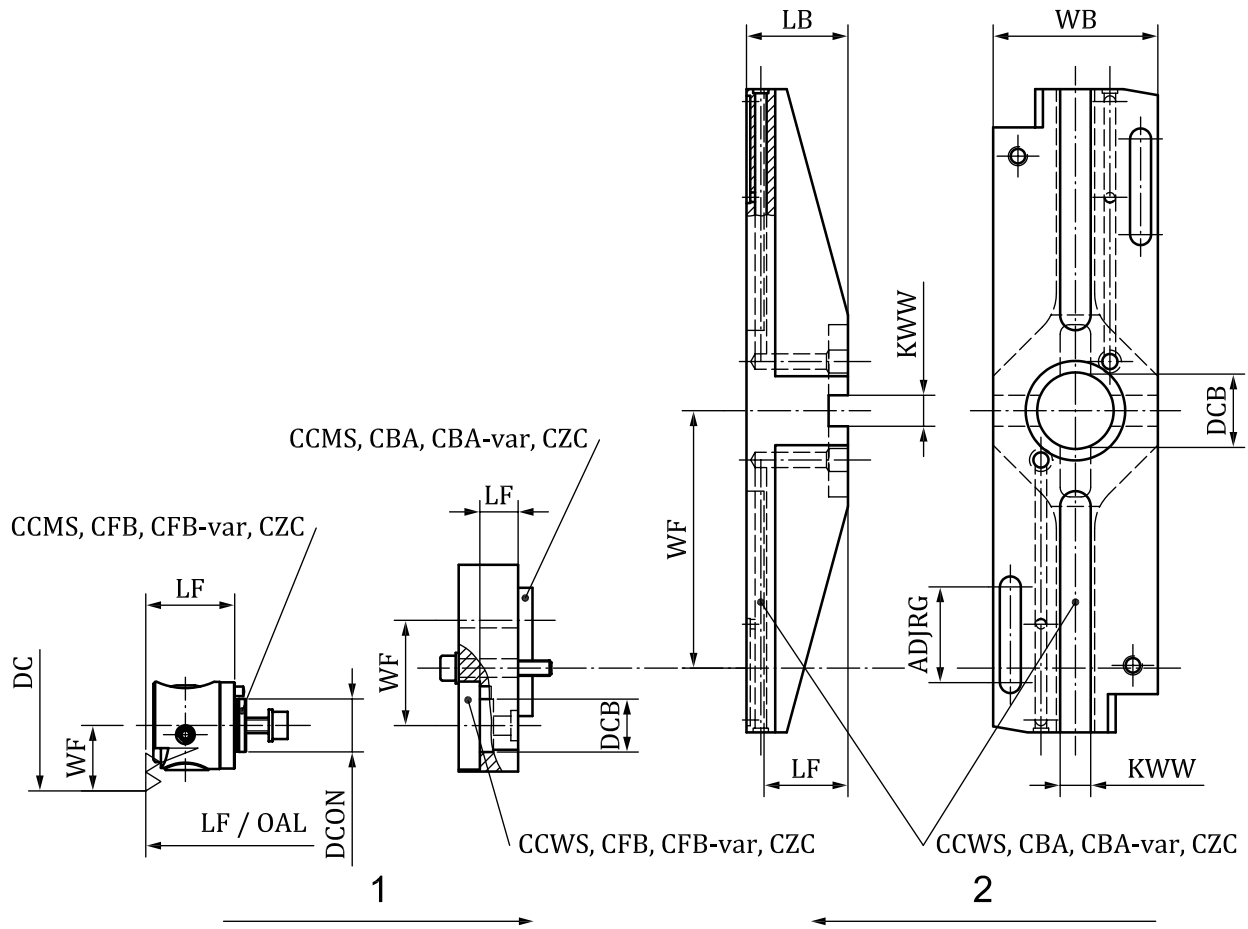

Key

- 1 machine side connection
- 2 workpiece side connection

Figure E.10 — CBC Coromant Bridge Connection

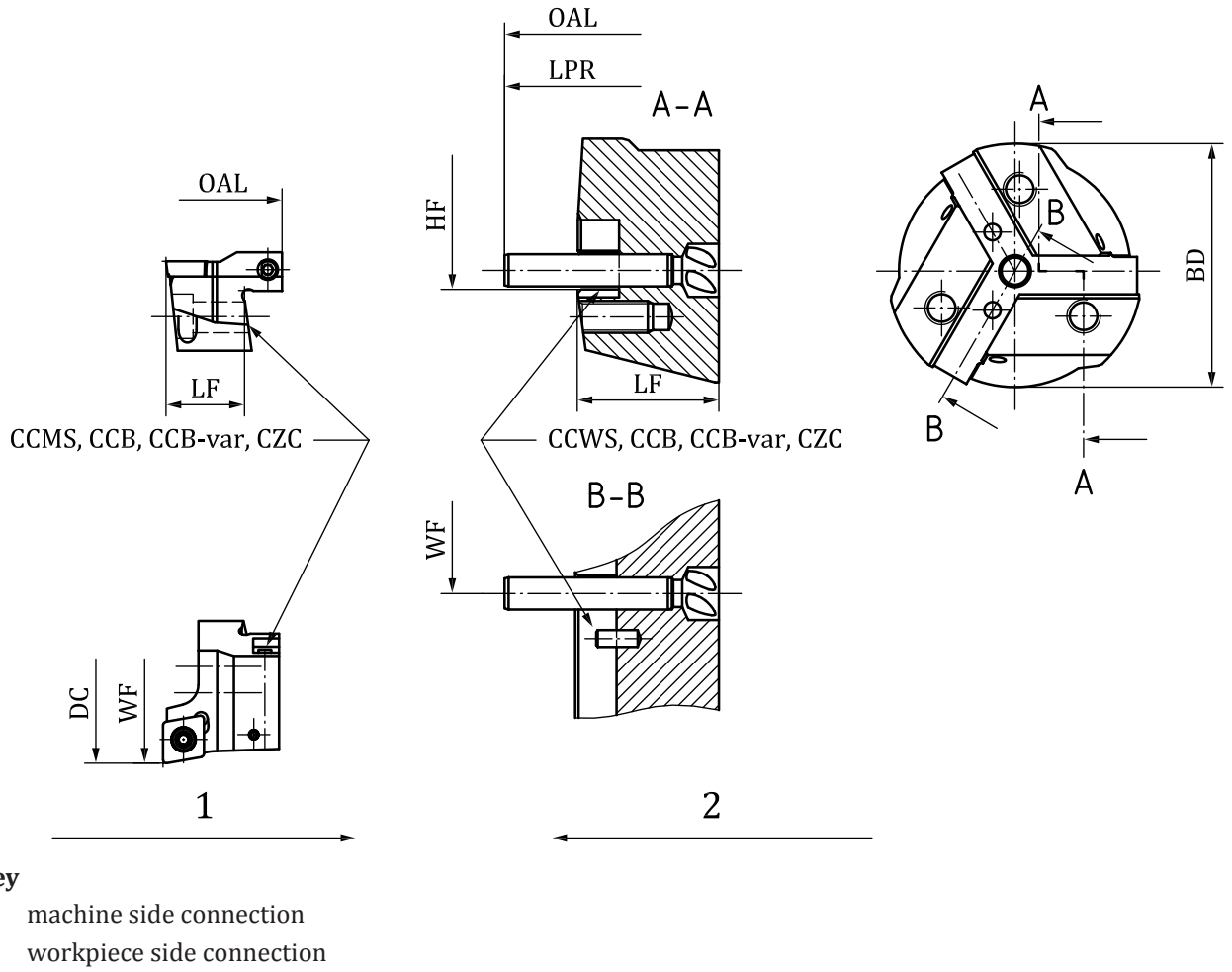
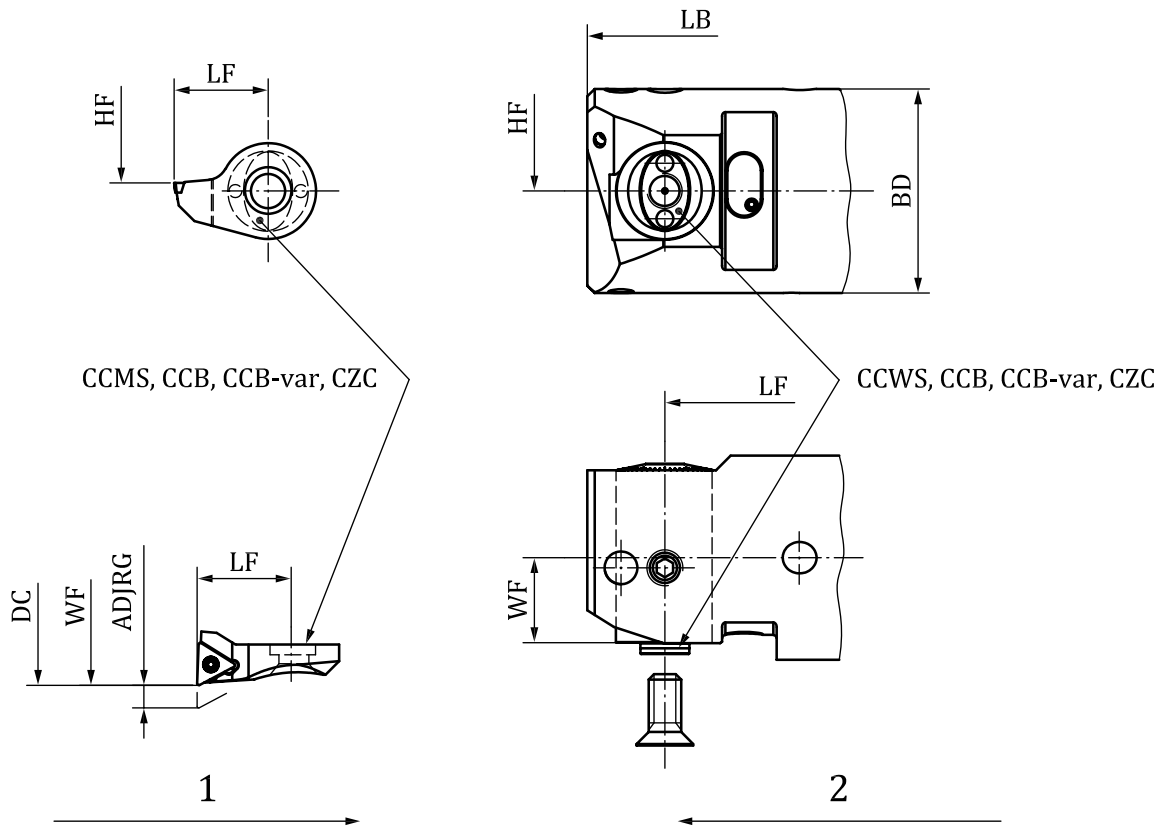

Figure E.11 — Variant 01 of CCB Coromant CoroBore



Key

- 1 machine side connection
- 2 workpiece side connection

Figure E.12 — Variant 02 of Coromant Corobore

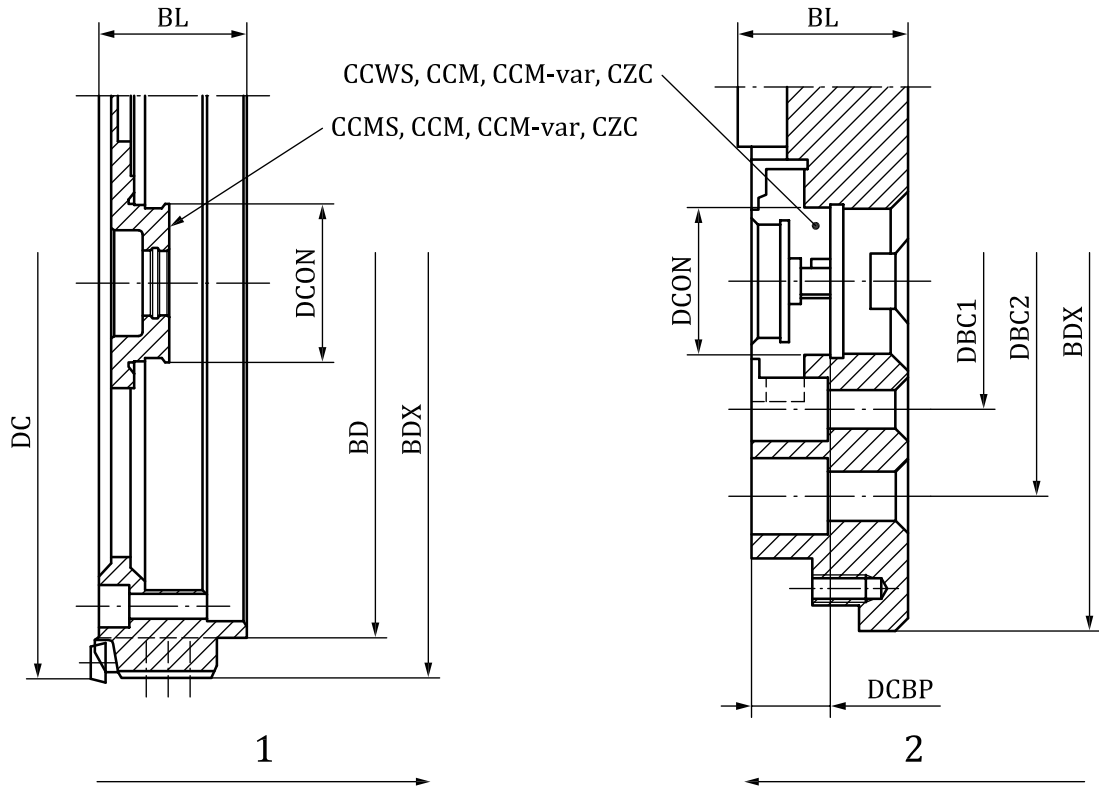

Key

- 1 machine side connection
- 2 workpiece side connection

Figure E.13 — CCM Coromant Cap Mounting

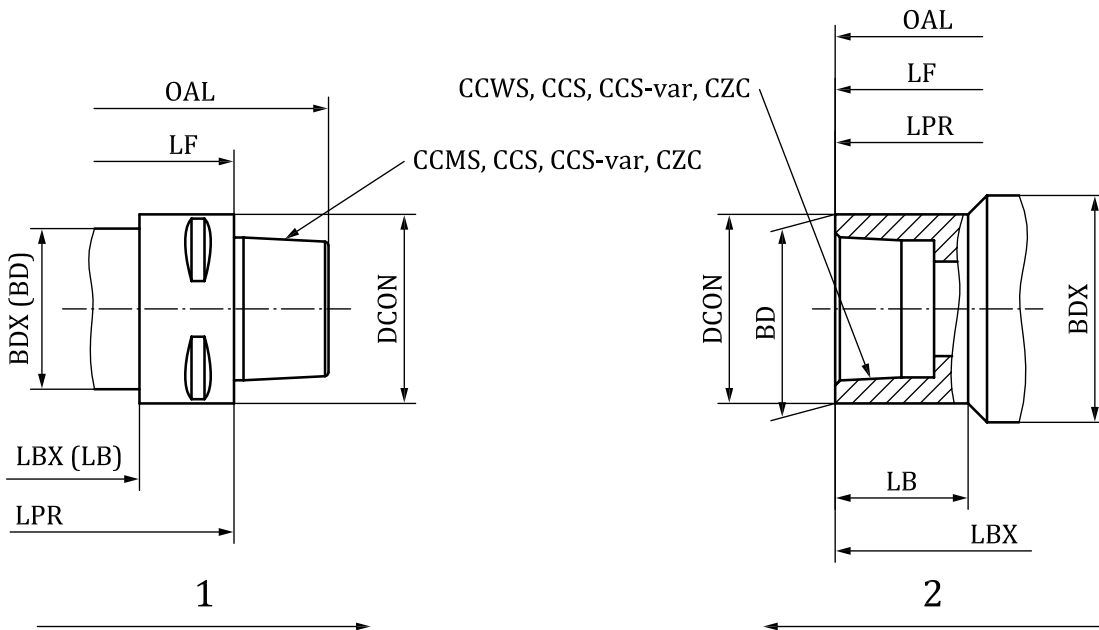

Key

- 1 machine side connection
- 2 workpiece side connection

Figure E.14 — CCS Coromant Capto System

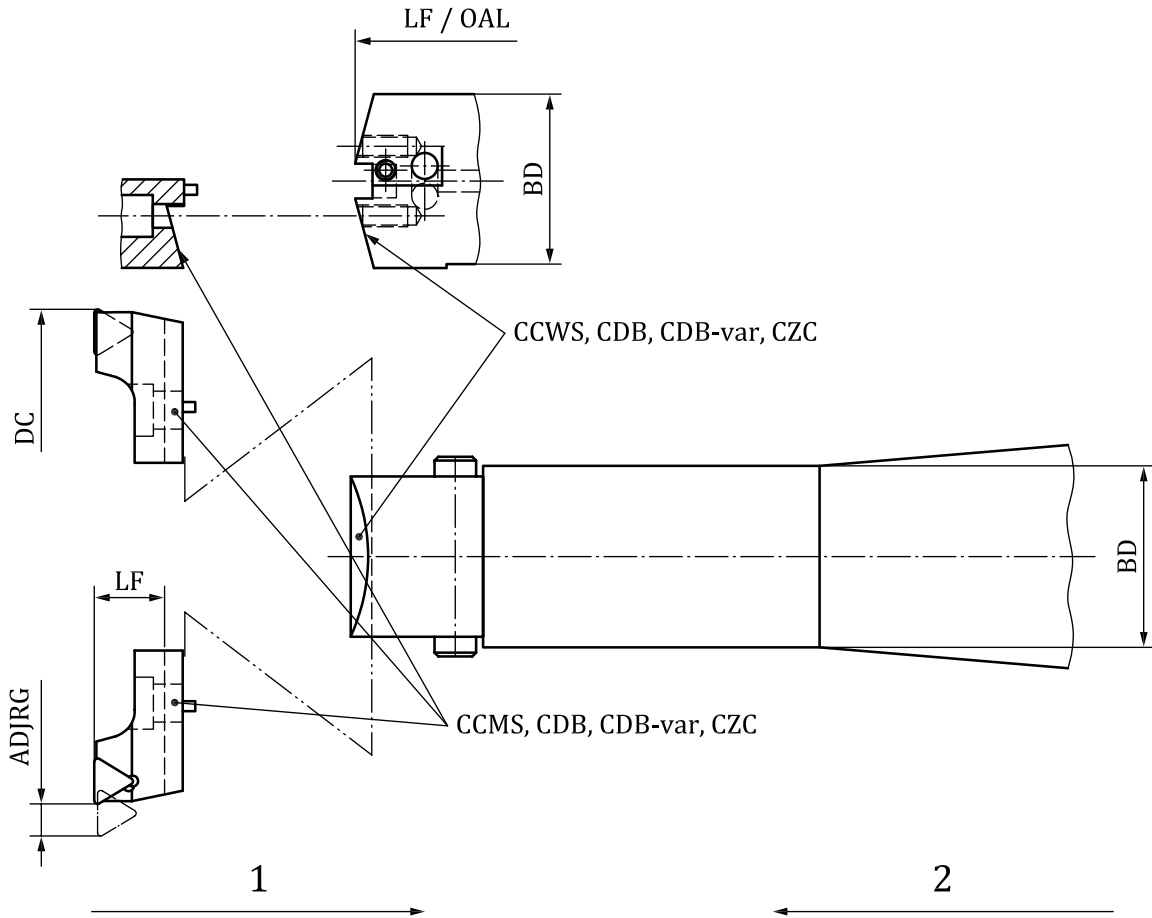

Key

- 1 machine side connection
- 2 workpiece side connection

Figure E.15 — Variant 01 of CDB Coromant Duobore

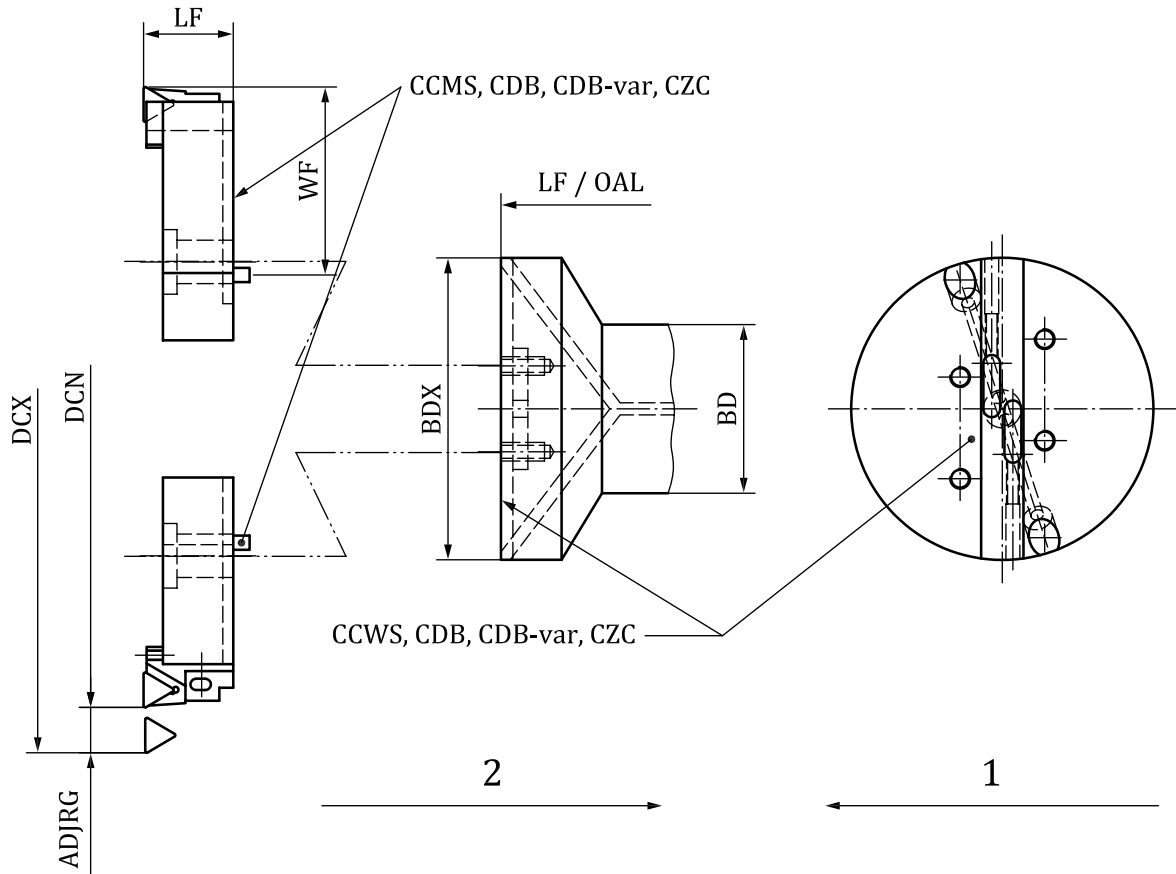
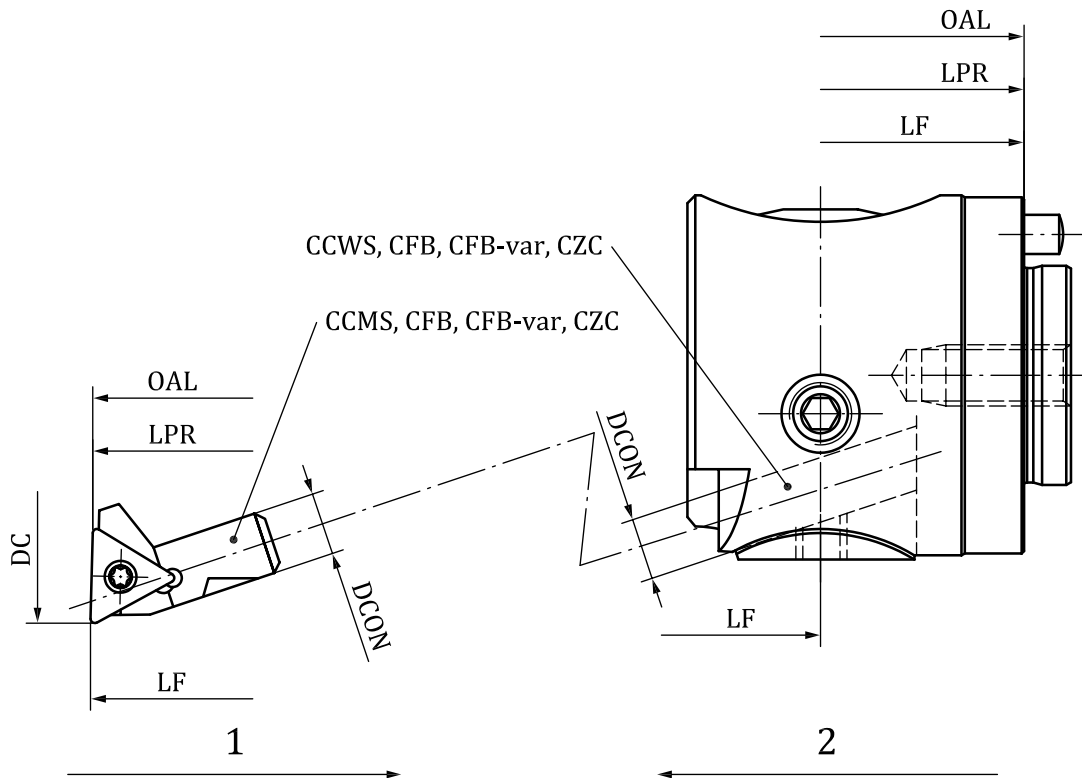

Figure E.16 — Variant 02 of CDB Coromant Duobore



Key

- 1 machine side connection
- 2 workpiece side connection

Figure E.17 — Variant 01 of CFB Coromant Fine Boring

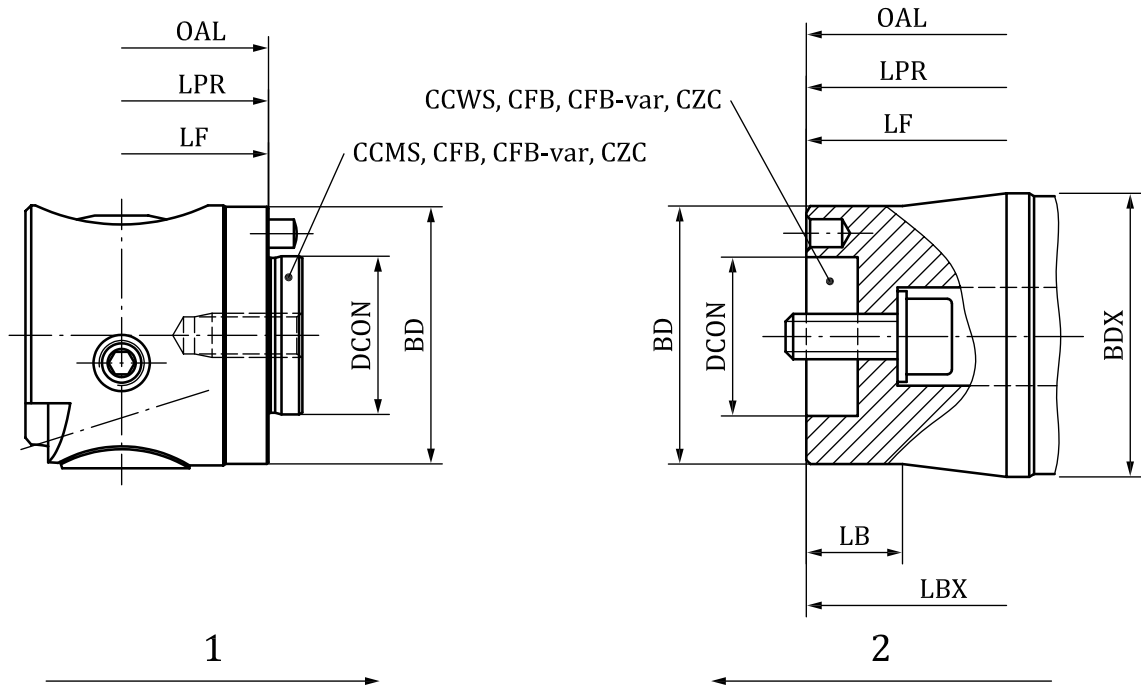

Key

- 1 machine side connection
- 2 workpiece side connection

Figure E.18 — Variant 02 of CFB Coromant Fine Boring

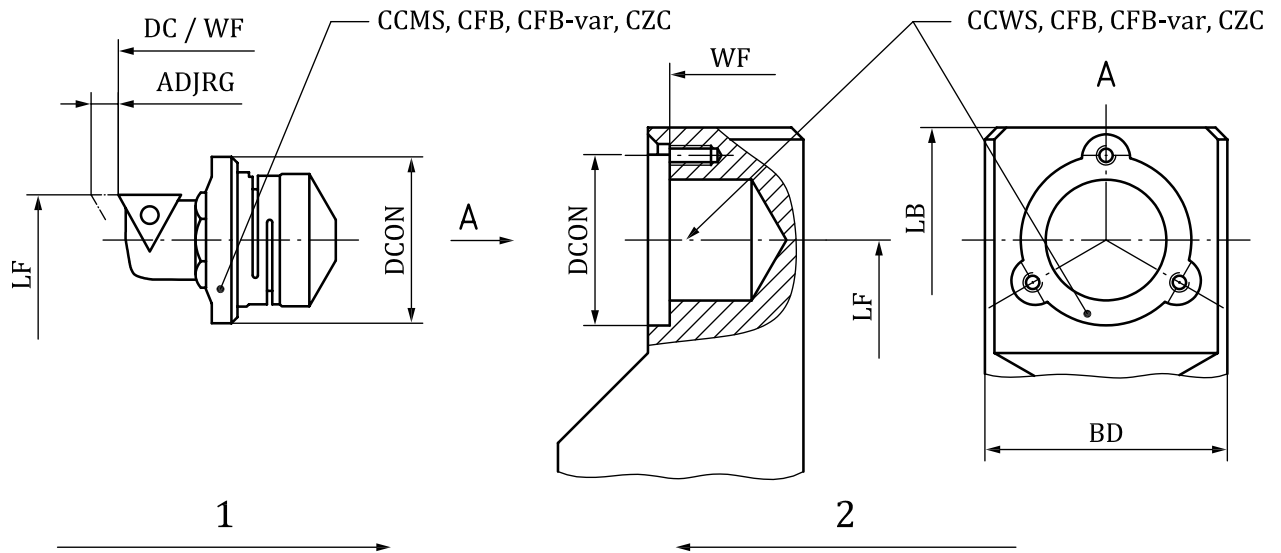

Key

- 1 machine side connection
- 2 workpiece side connection

Figure E.19 — Variant 03 of CFB Coromant Fine Boring

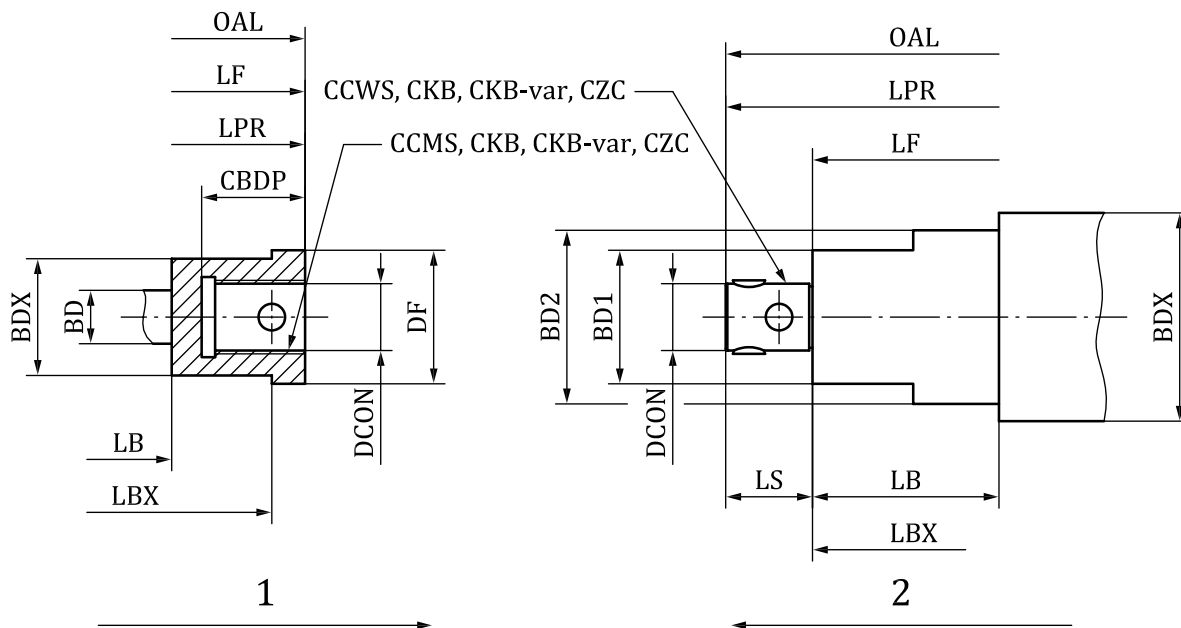

- Key**
- 1 machine side connection
 - 2 workpiece side connection

Figure E.20 — Variant 01 of CKB Kaiser bore connection

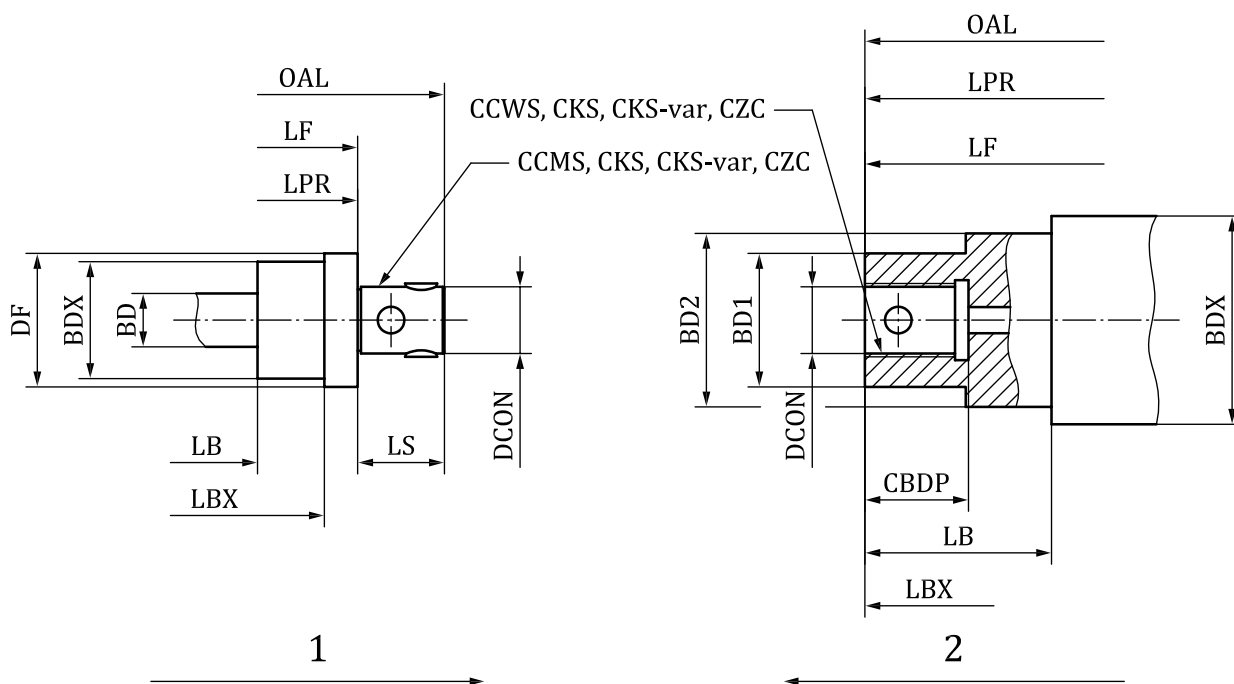

- Key**
- 1 machine side connection
 - 2 workpiece side connection

Figure E.21 — CKS Kaiser shank connection

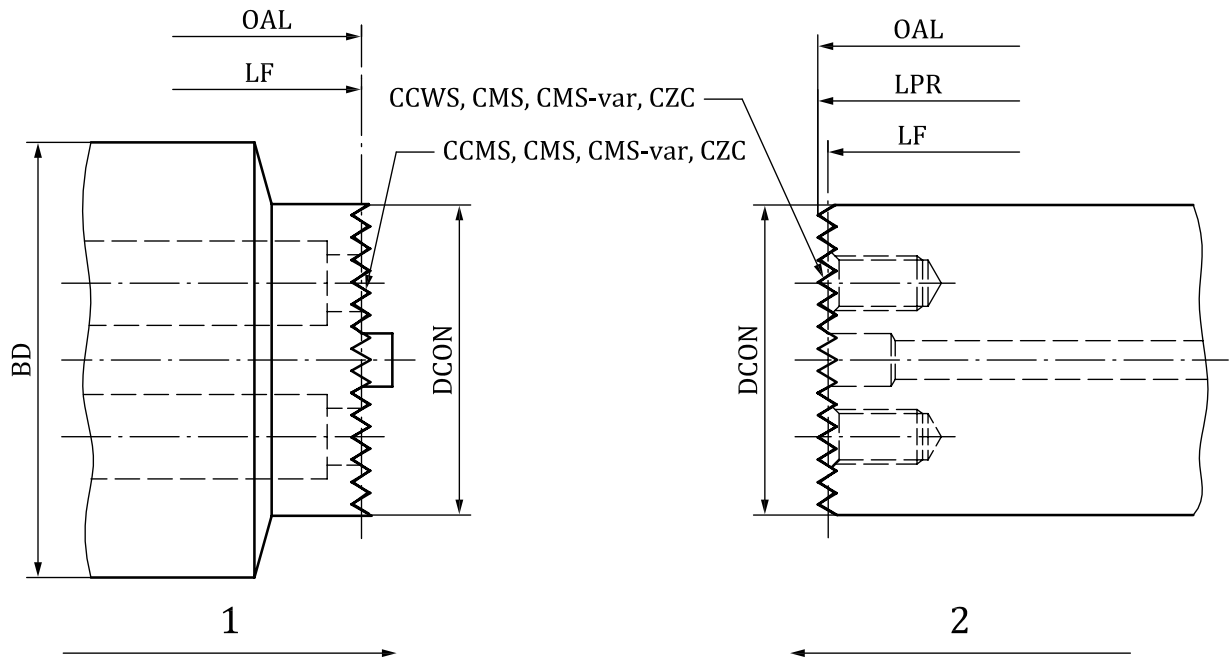

Key

- 1 machine side connection
- 2 workpiece side connection

Figure E.22 — CMS Coromant Modular Serrated mounting

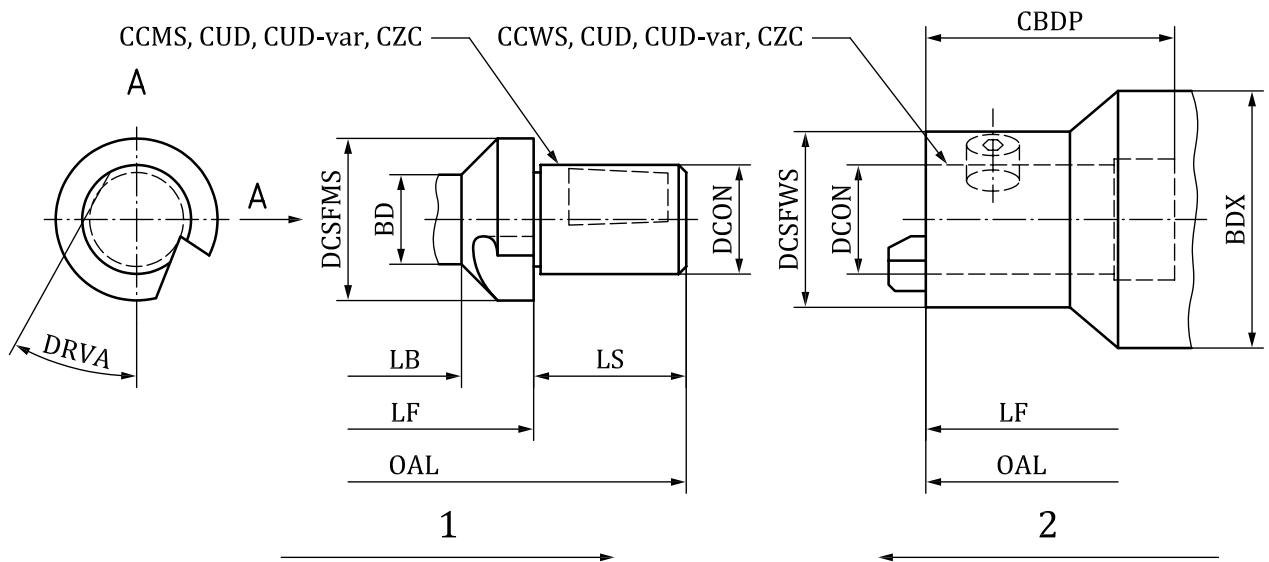

Key

- 1 machine side connection
- 2 workpiece side connection

Figure E.23 — CUD Coromant U-drill connection

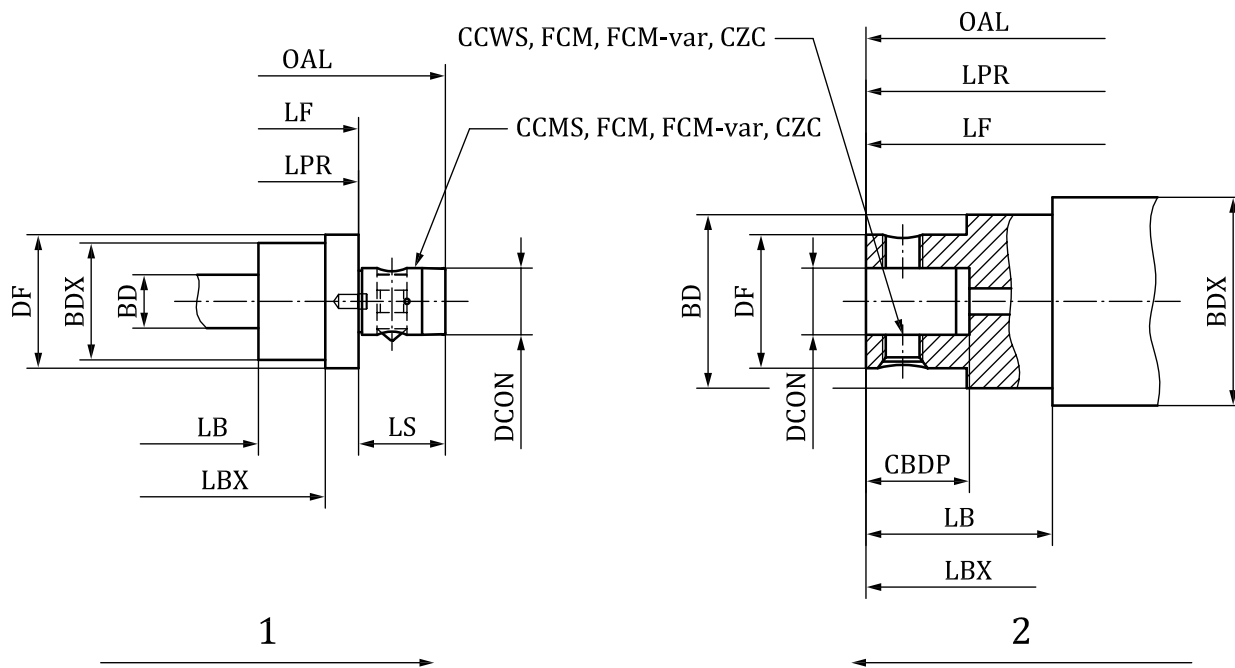

- Key**
 1 machine side connection
 2 workpiece side connection

Figure E.24 — FCM flexible coupling modular

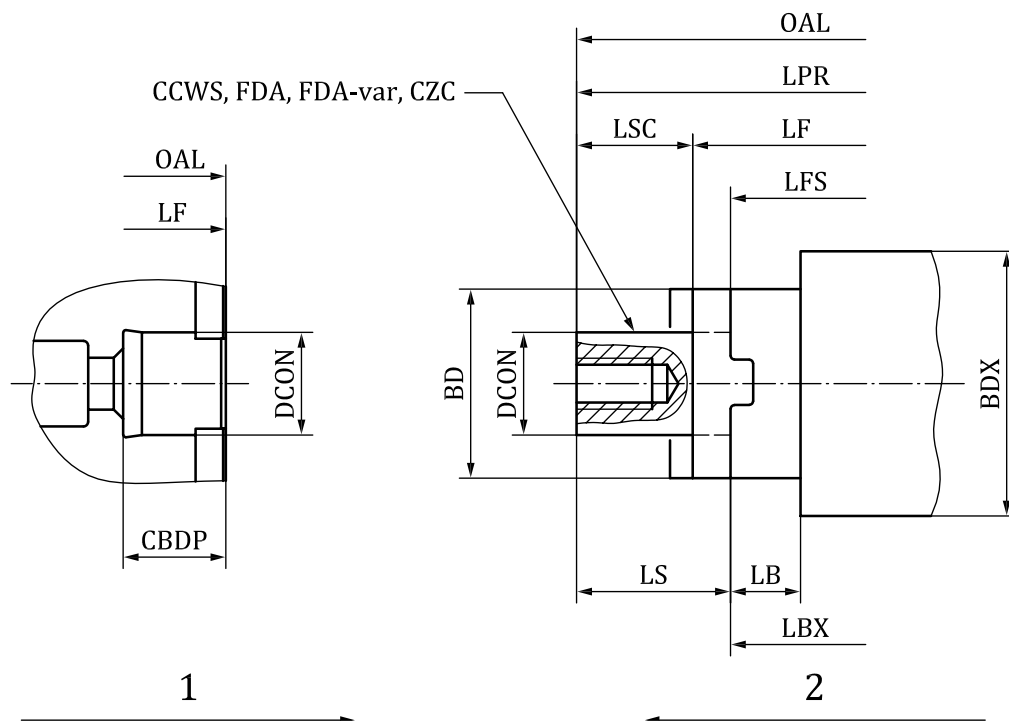

- Key**
 1 machine side connection
 2 workpiece side connection

Figure E.25 — FDA milling arbor connection

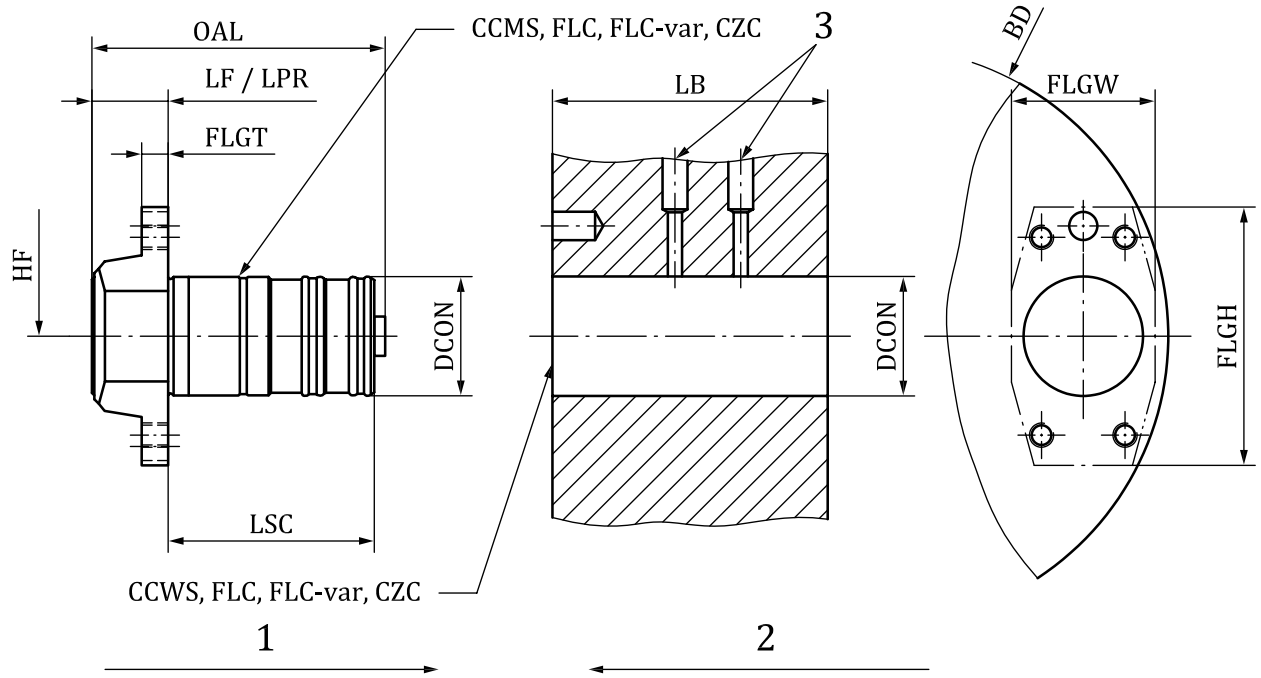

Key

- 1 machine side connection
- 2 workpiece side connection

Figure E.26 — FLC flange connection Coromant

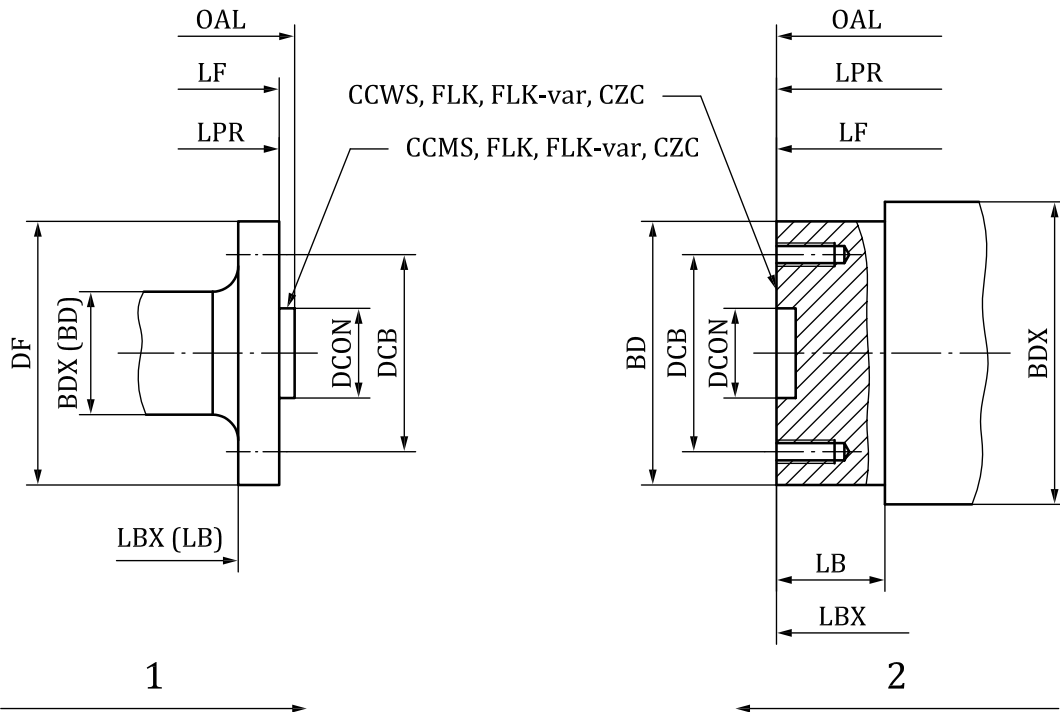

Key

- 1 machine side connection
- 2 workpiece side connection

Figure E.27 — FLK flange connector Kennametal

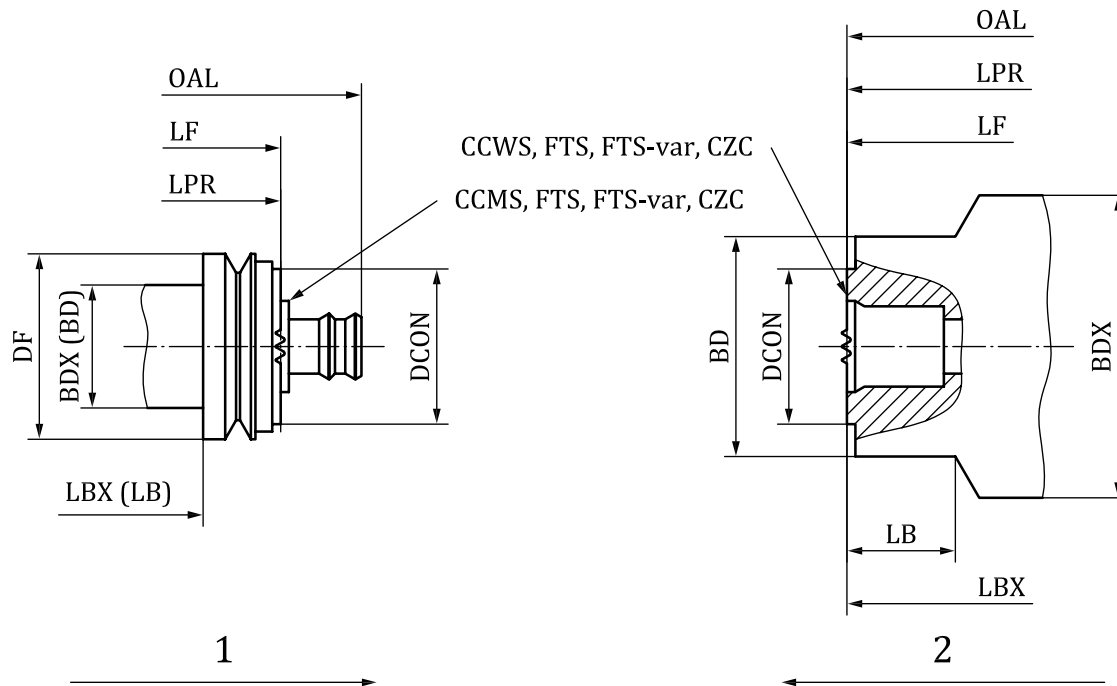

Key

- 1 machine side connection
- 2 workpiece side connection

Figure E.28 — FTS flexible tooling system

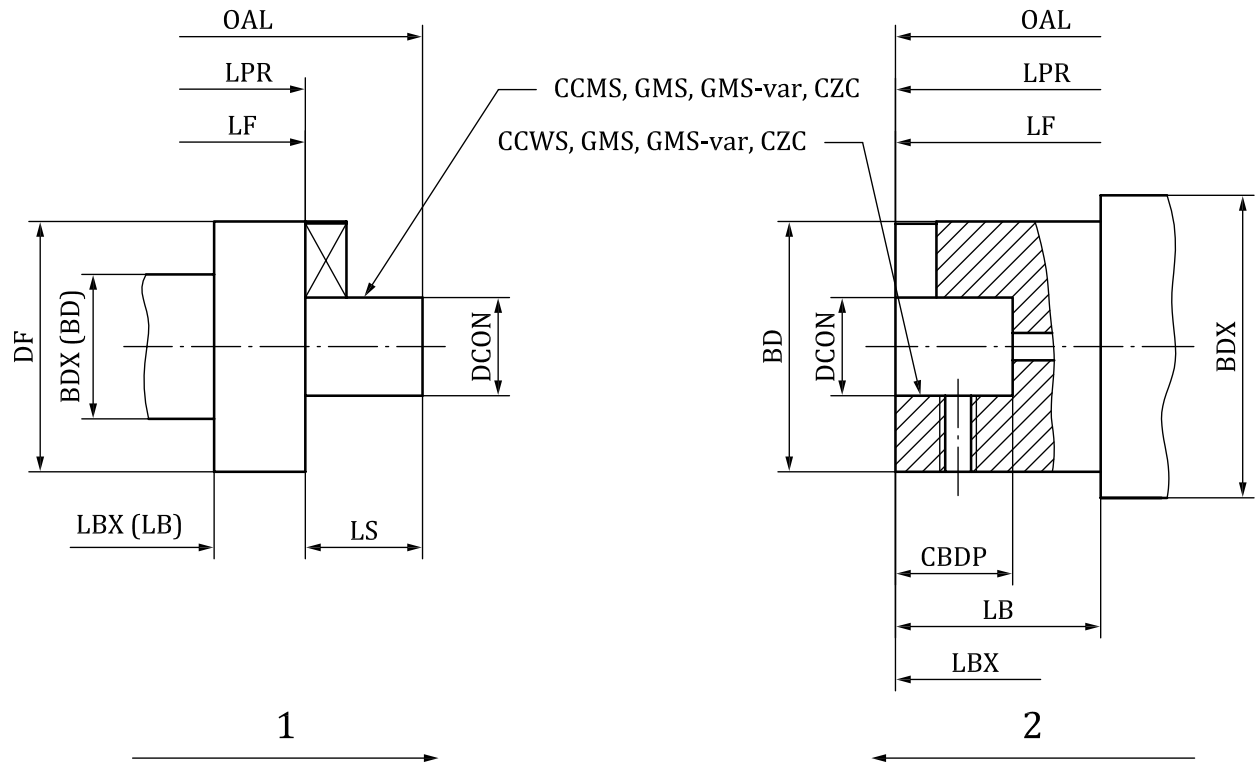

Key

- 1 machine side connection
- 2 workpiece side connection

Figure E.29 — GMS Graflex modular system SECO

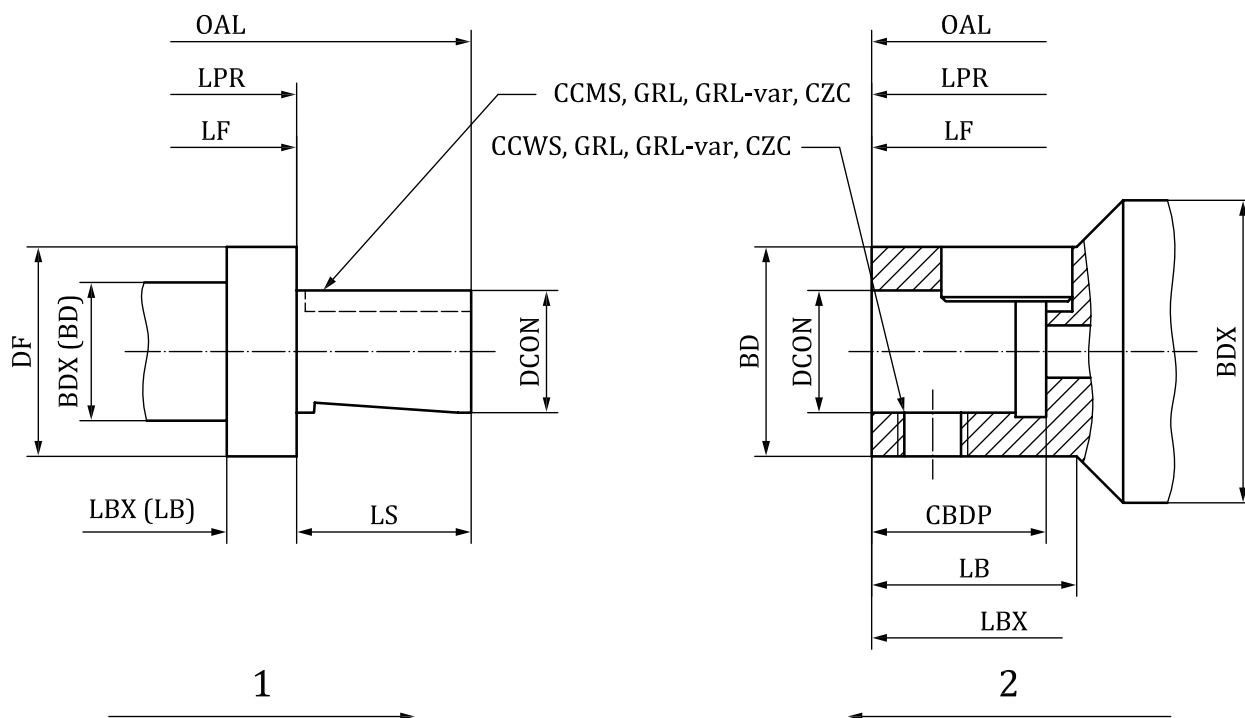

Key

- 1 machine side connection
- 2 workpiece side connection

Figure E.30 — GRL Granlund connection

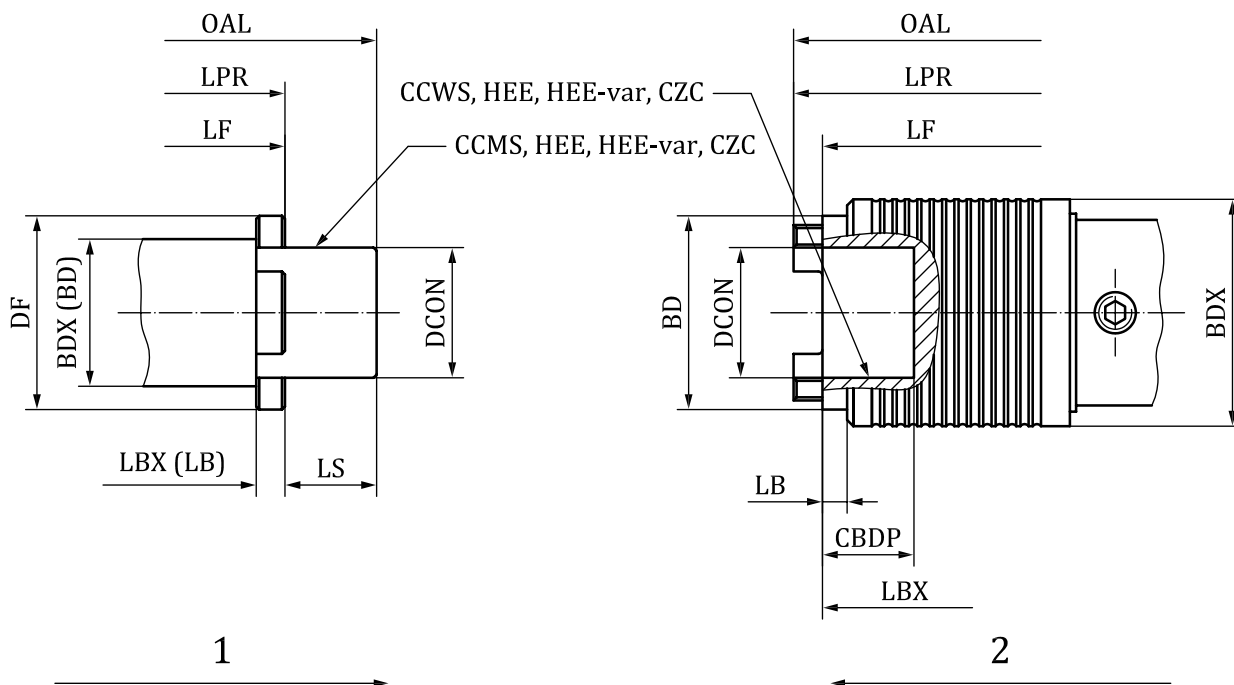

Key

- 1 machine side connection
- 2 workpiece side connection

Figure E.31 — HEE HE-/HF-system EMUGE

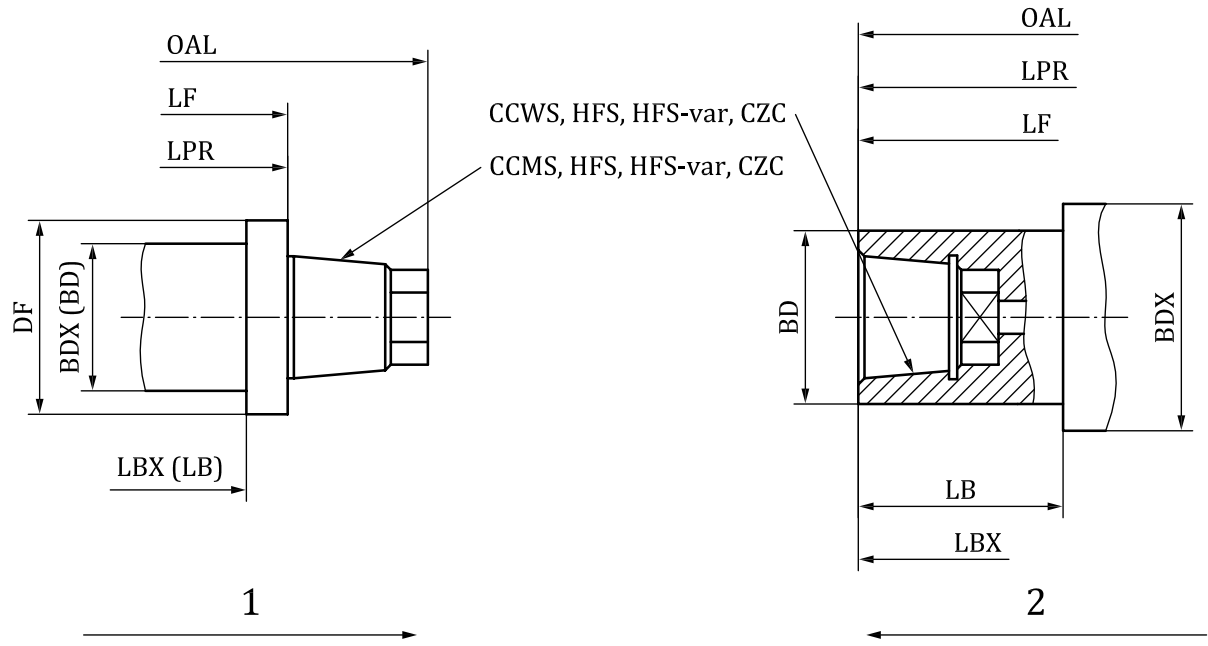

Key

- 1 machine side connection
- 2 workpiece side connection

Figure E.32 — HFS head fitting system Mapal

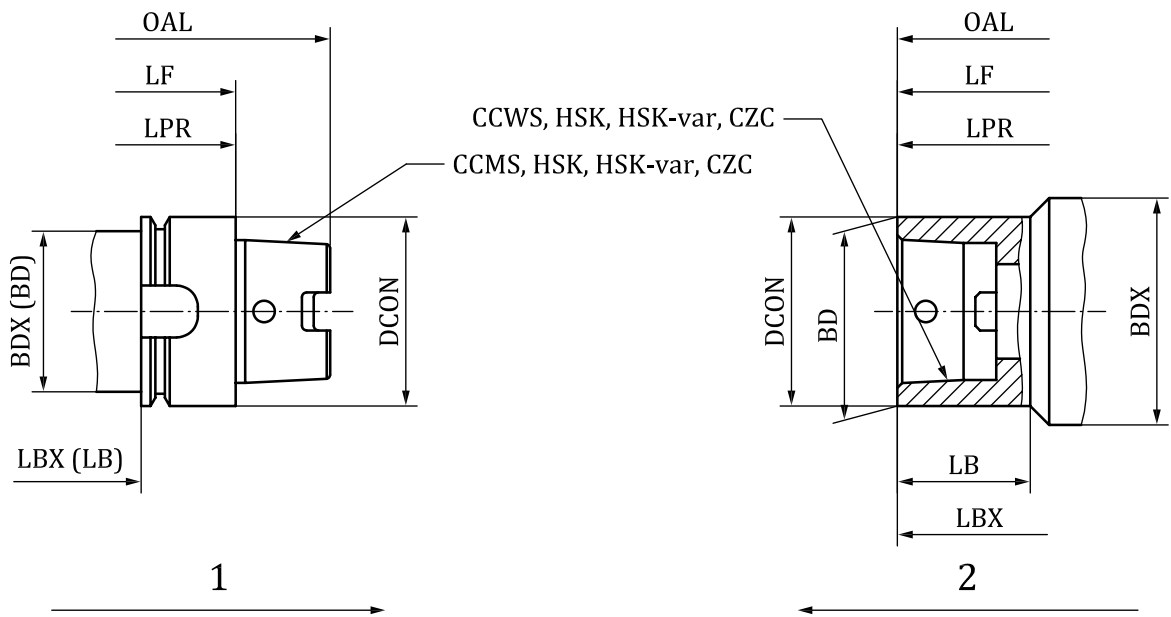

Key

- 1 machine side connection
- 2 workpiece side connection

Figure E.33 — HSK hollow taper shank

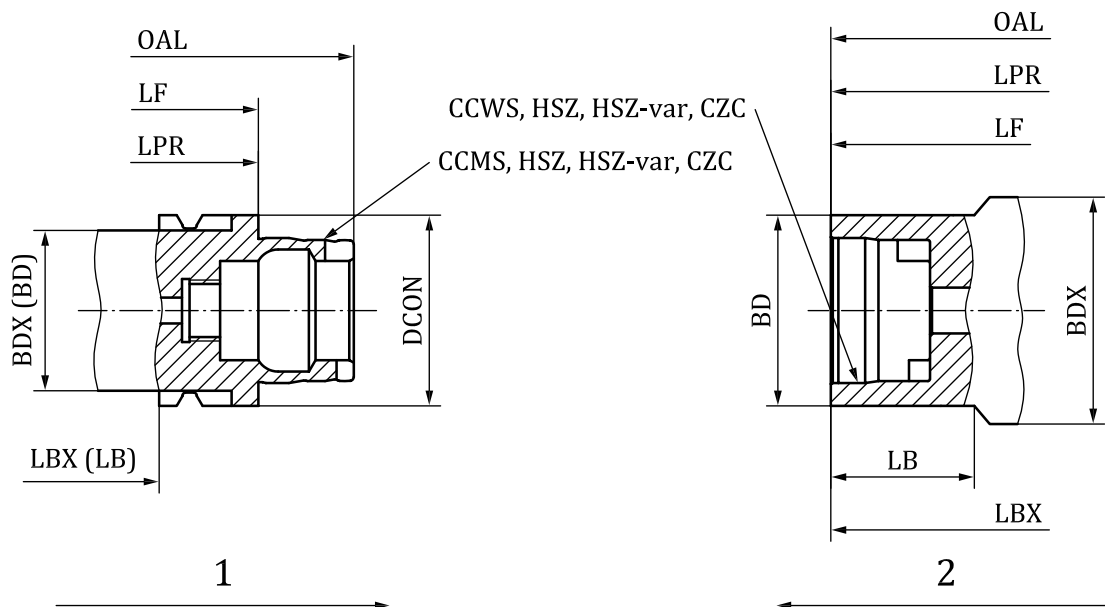

- Key**
- 1 machine side connection
 - 2 workpiece side connection

Figure E.34 — HSZ hollow cylindrical shank

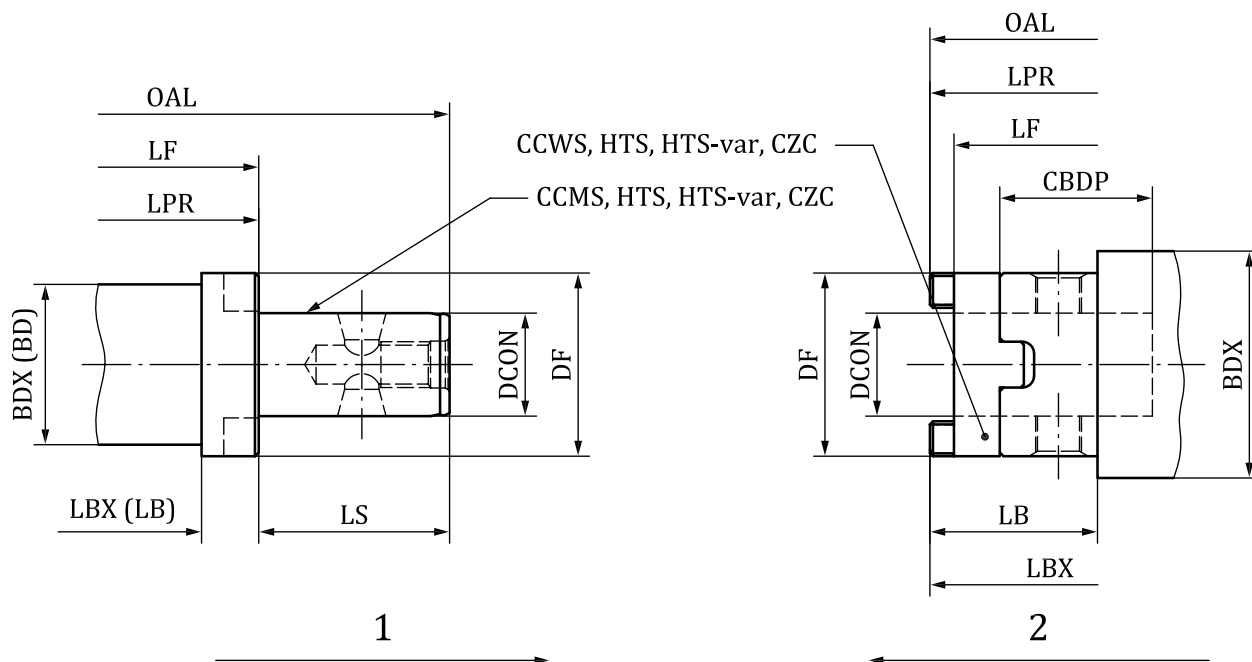

- Key**
- 1 machine side connection
 - 2 workpiece side connection

Figure E.35 — HTS deep drilling system

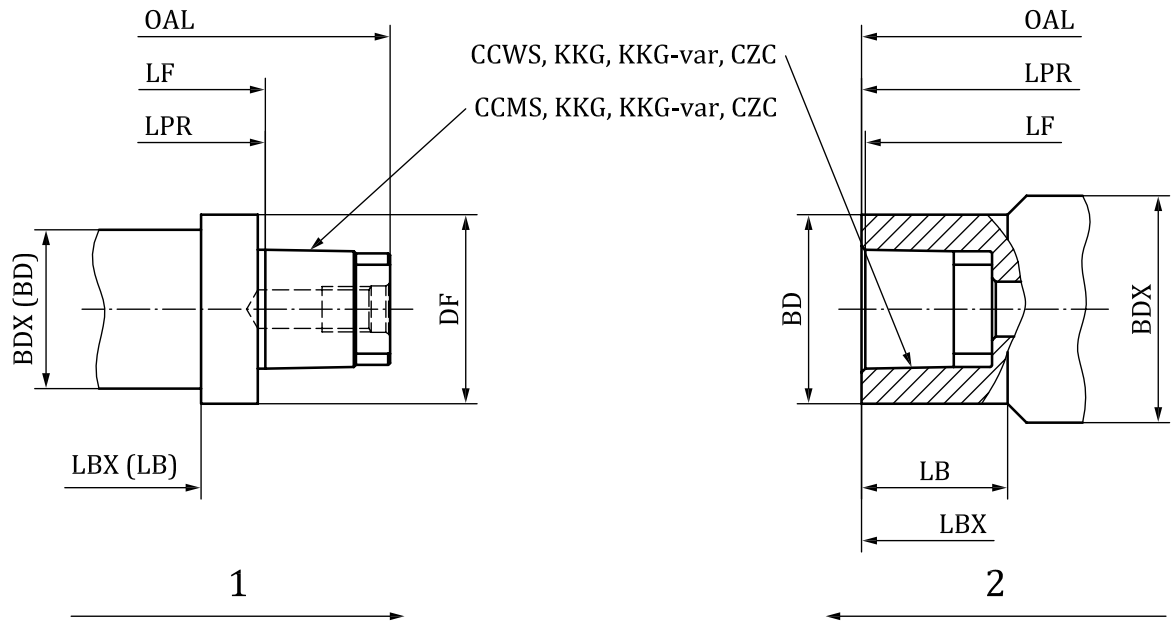

Key

- 1 machine side connection
- 2 workpiece side connection

Figure E.36 — KKG stub taper

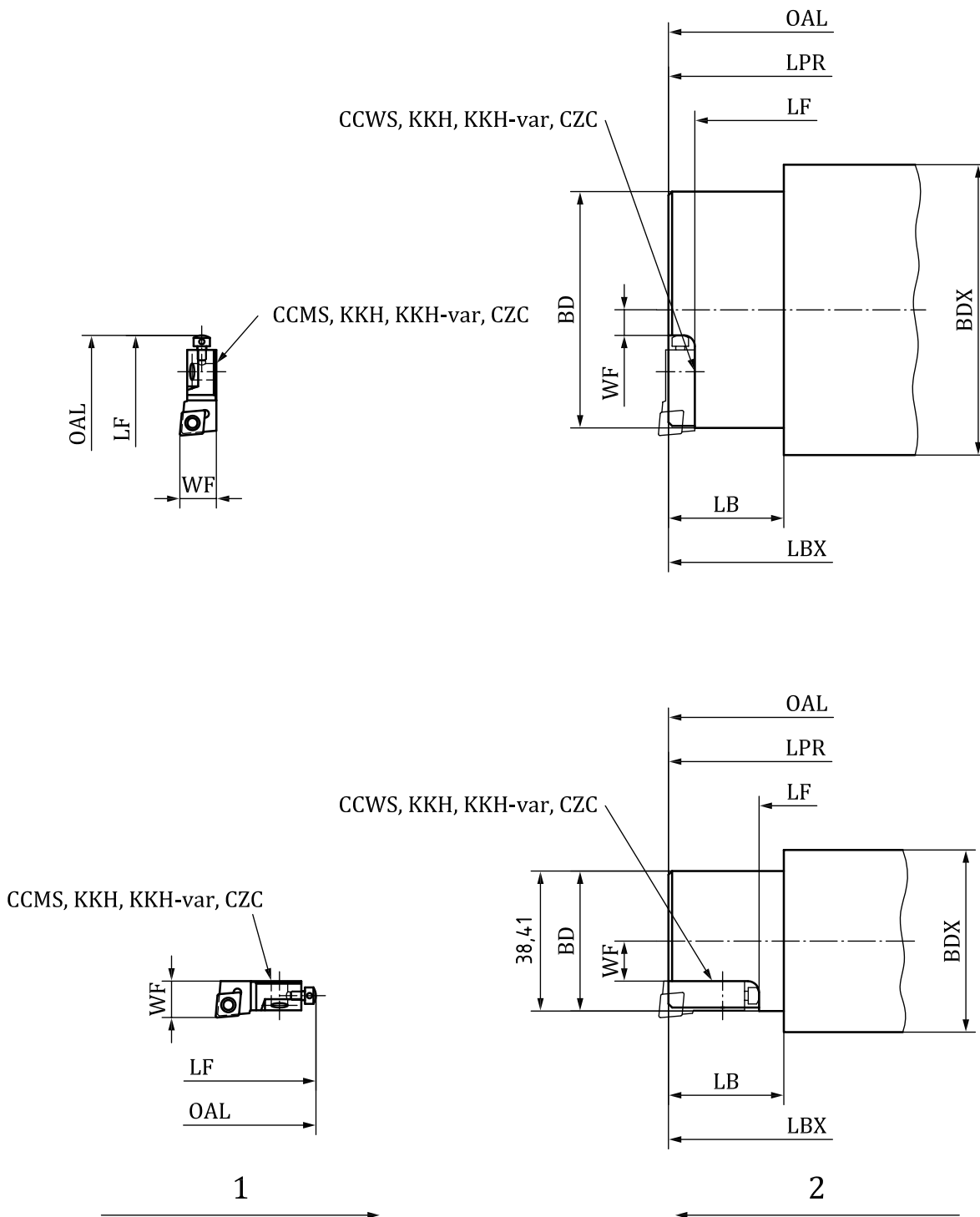

- Key**
- 1 machine side connection
 - 2 workpiece side connection

Figure E.37 — KKH cartridge interface

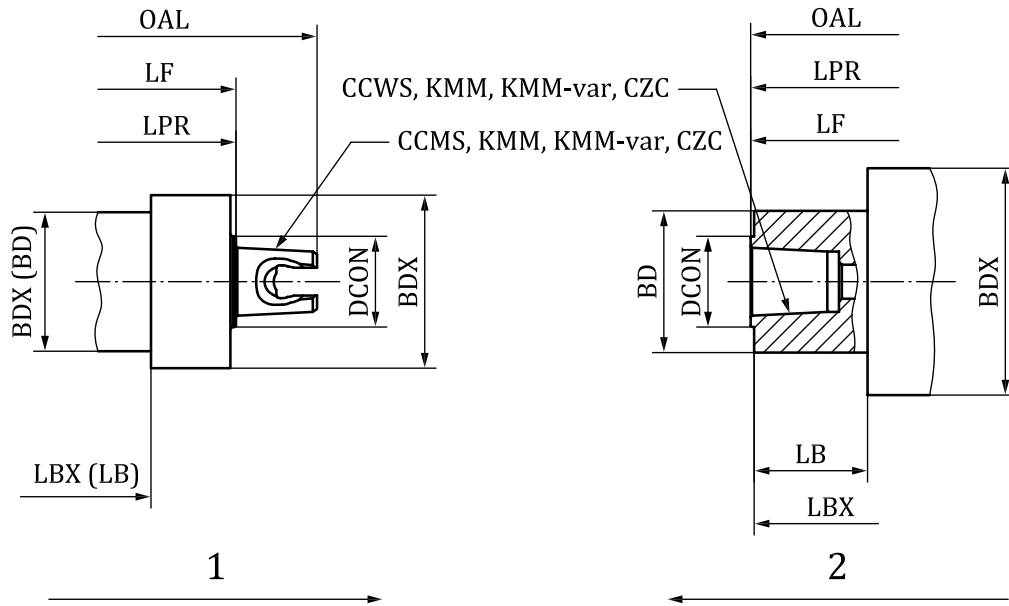

Key

- 1 machine side connection
- 2 workpiece side connection

Figure E.38 — KMM Kennametal Micro system

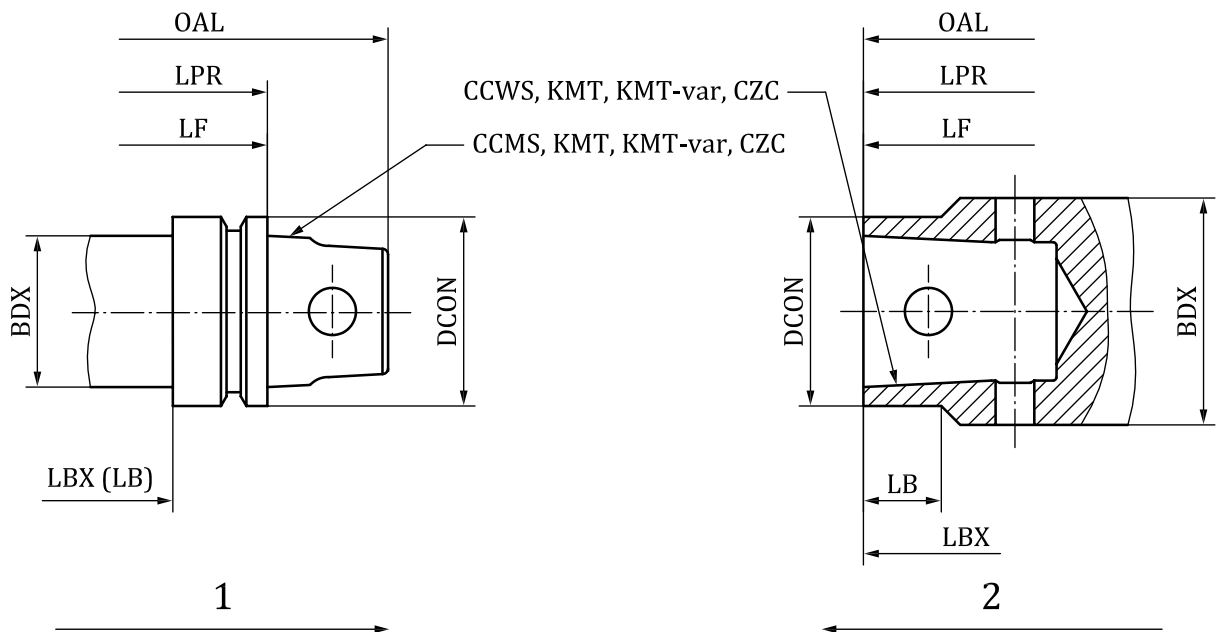

Key

- 1 machine side connection
- 2 workpiece side connection

Figure E.39 — KMT KM-UTS system Kennametal/Widia

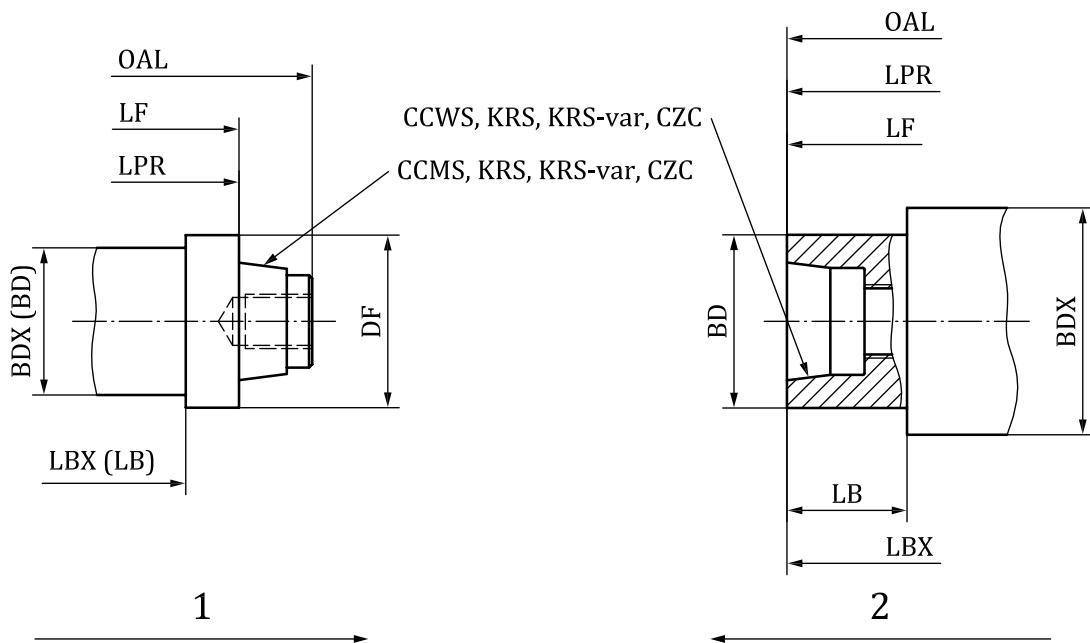

Key

- 1 machine side connection
- 2 workpiece side connection

Figure E.40 — KRS Kennametal Romicon system

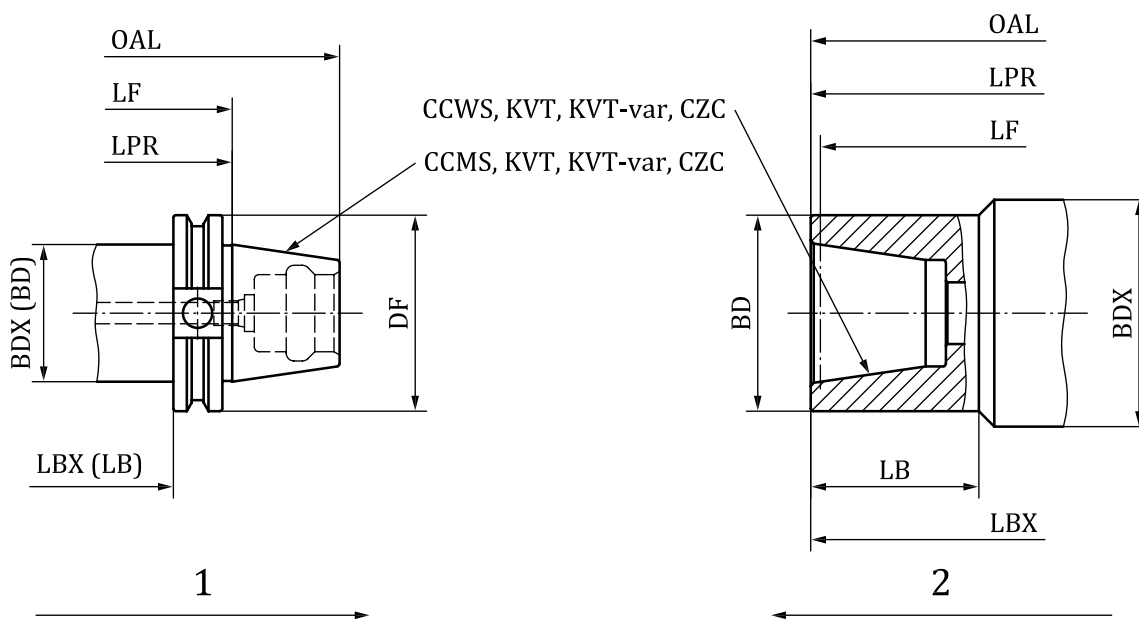

Key

- 1 machine side connection
- 2 workpiece side connection

Figure E.41 — KVT KV system Kennametal

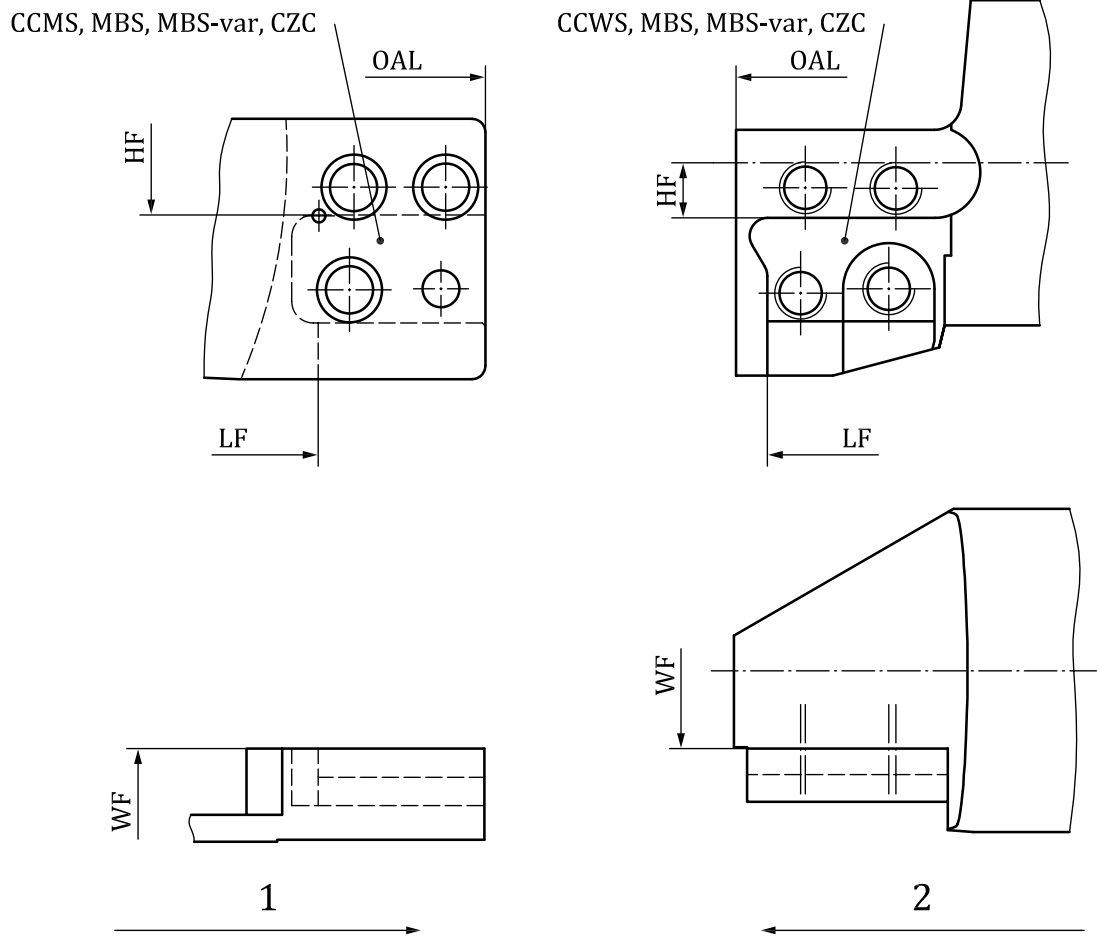

Key

- 1 machine side connection
- 2 workpiece side connection

Figure E.42 — MBS Multi Blade System Coromant

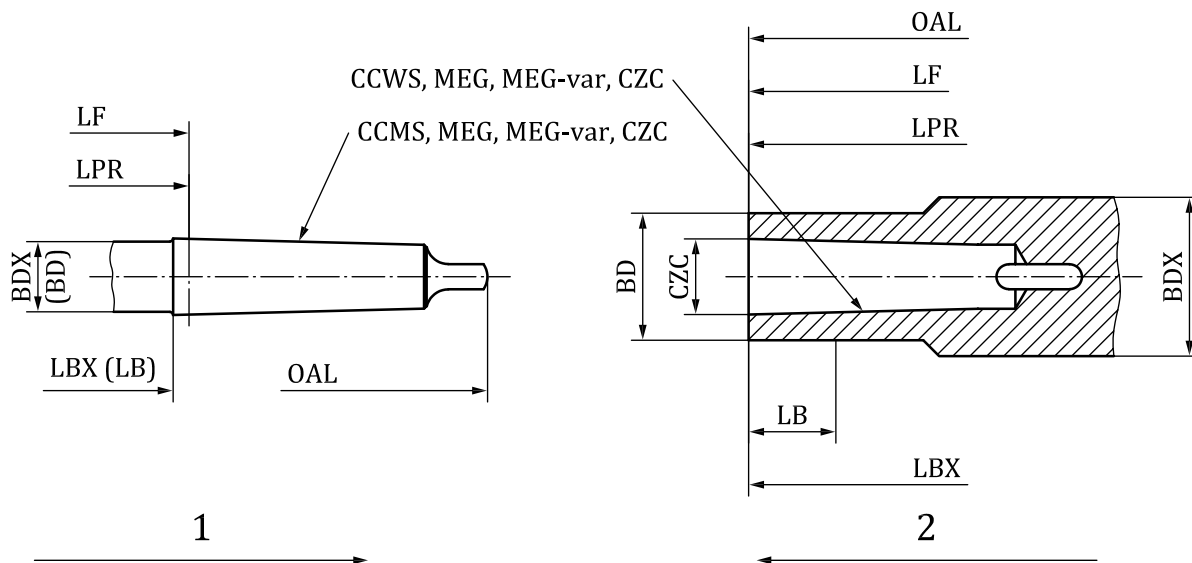

Key

- 1 machine side connection
- 2 workpiece side connection

Figure E.43 — MEG metric taper

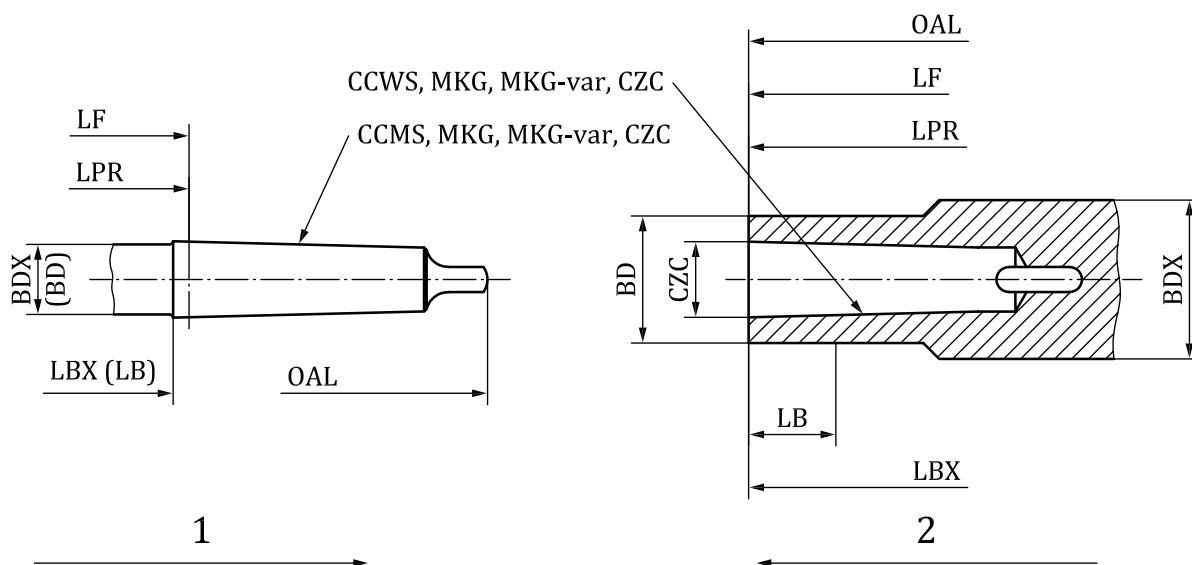

Key

- 1 machine side connection
- 2 workpiece side connection

Figure E.44 — MKG Morse taper

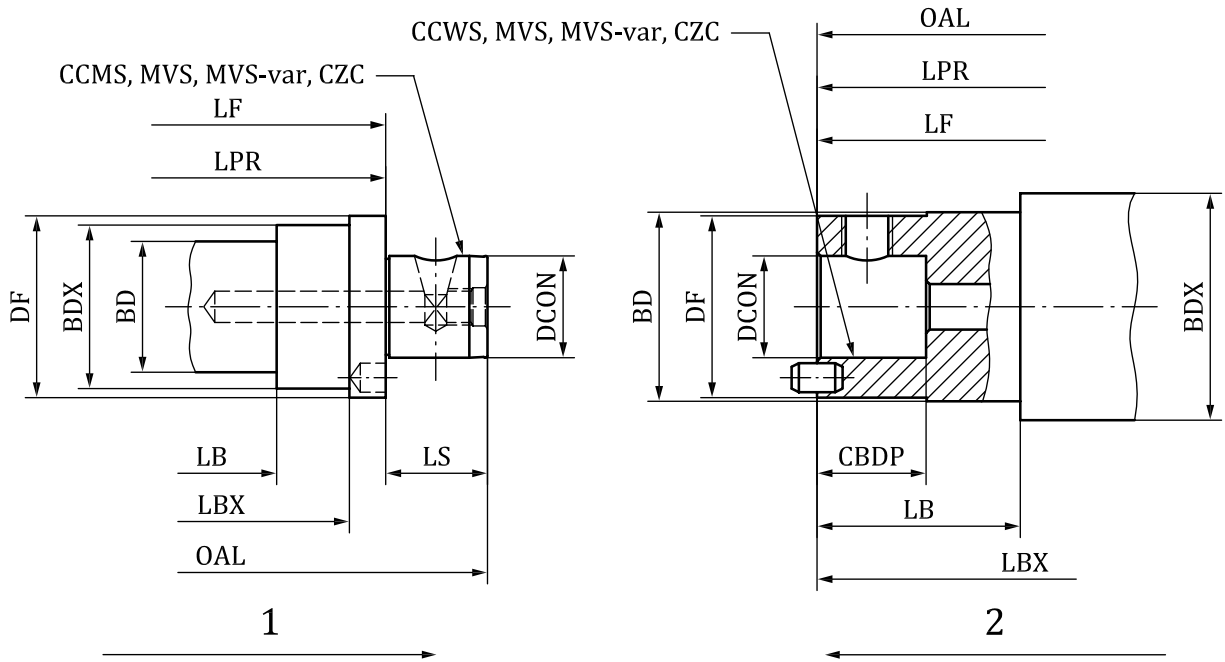

Key

- 1 machine side connection
- 2 workpiece side connection

Figure E.45 — MVS modular connection system Wohlhaupter

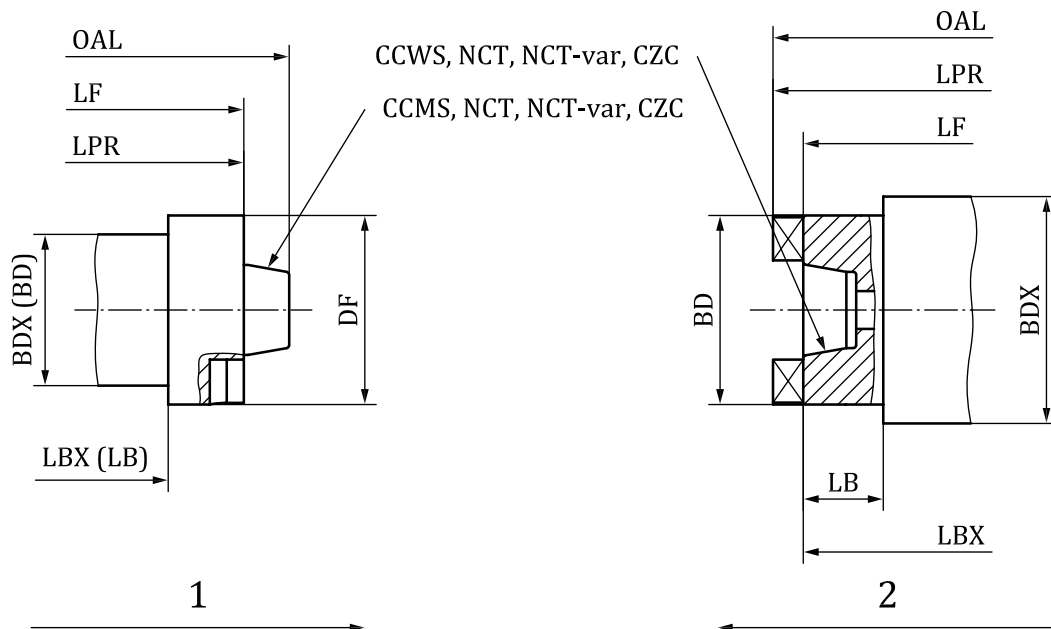

Key

- 1 machine side connection
- 2 workpiece side connection

Figure E.46 — NCT Novex-NC-Tools Walter

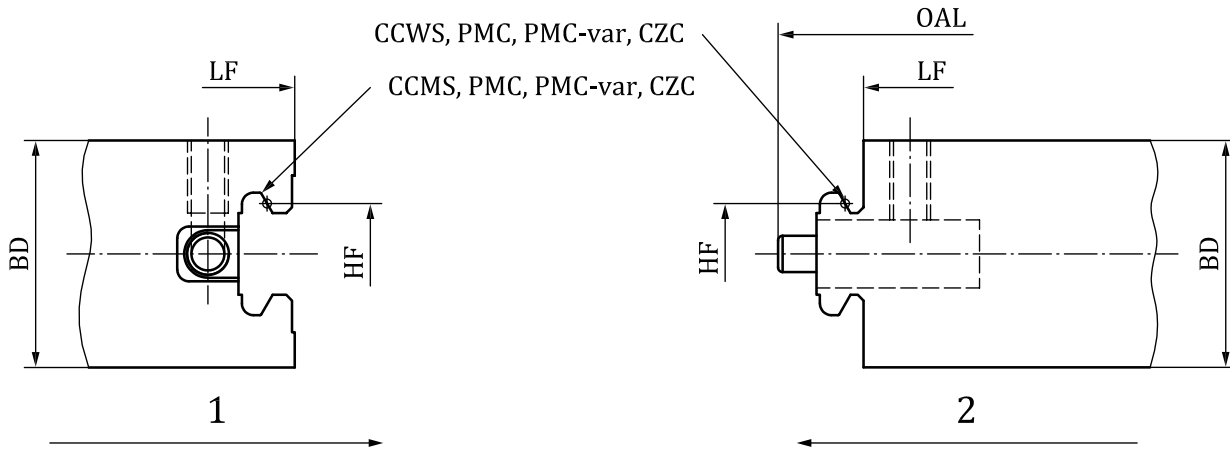

- Key**
- 1 machine side connection
 - 2 workpiece side connection

Figure E.47 — PMC prismatic connection Coromant

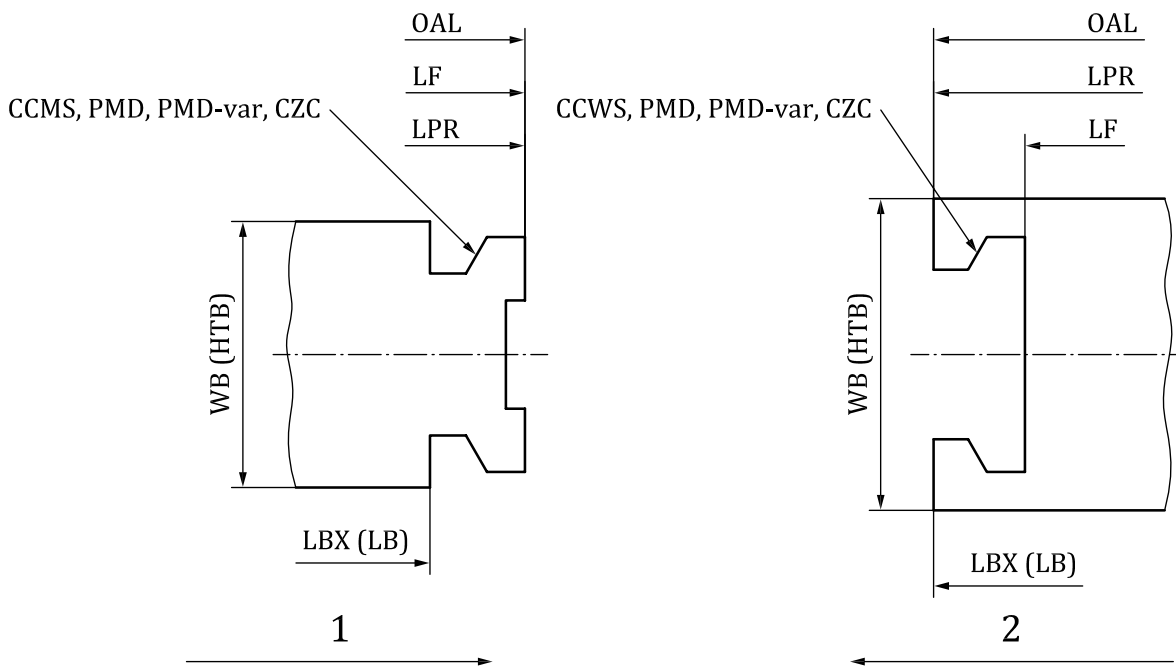

- Key**
- 1 machine side connection
 - 2 workpiece side connection

Figure E.48 — PMD prismatic connection standard

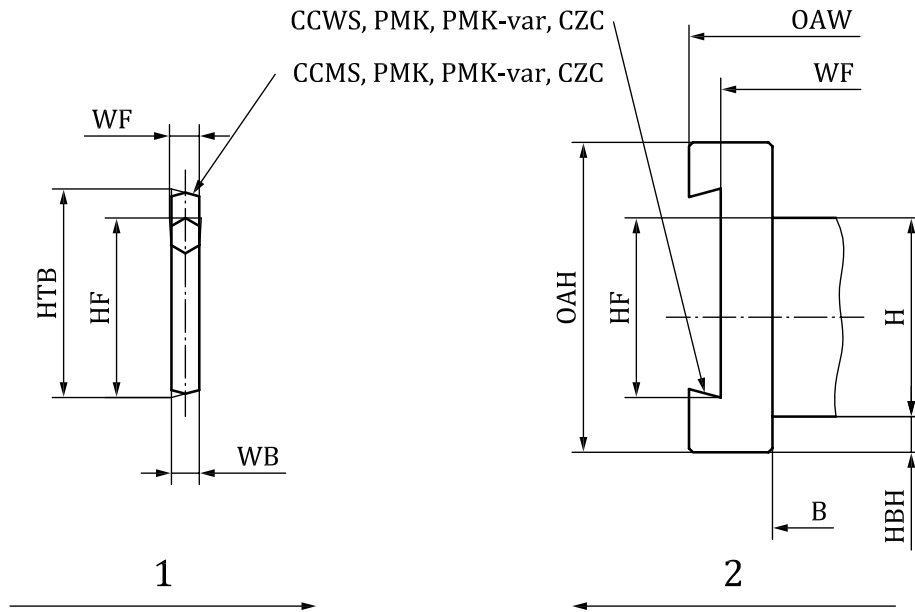

Key

- 1 machine side connection
- 2 workpiece side connection

Figure E.49 — PMK prismatic connection Kennametal

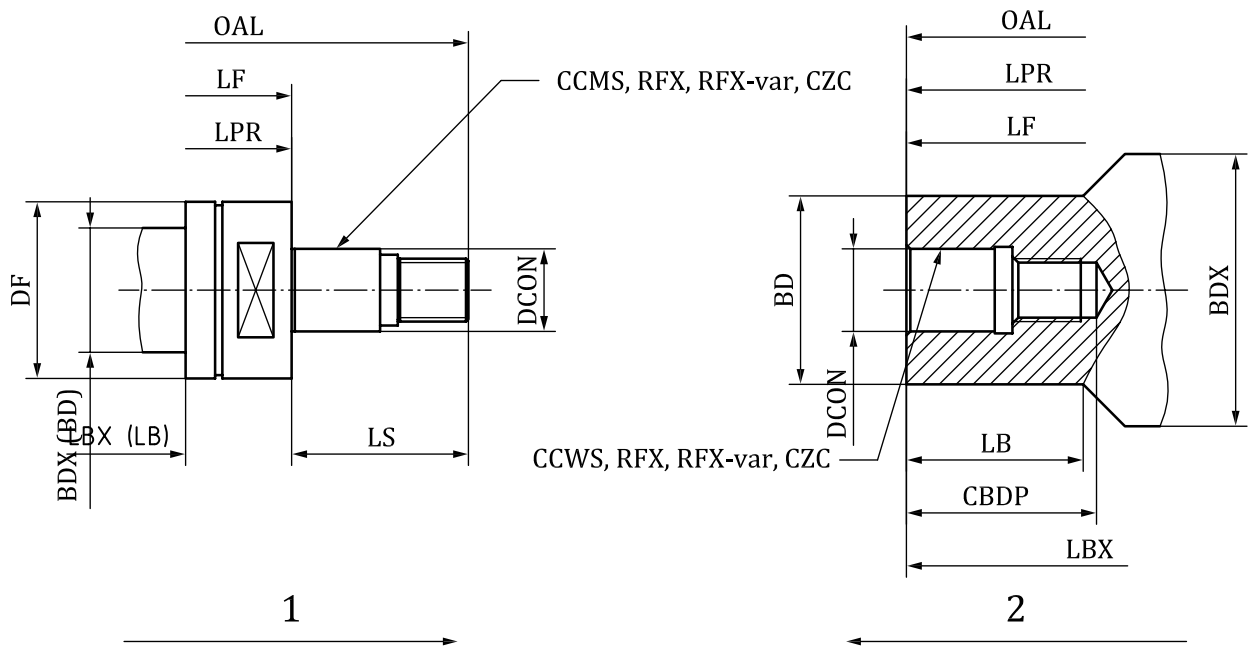

Key

- 1 machine side connection
- 2 workpiece side connection

Figure E.50 — RFX Rotaflex system Widia

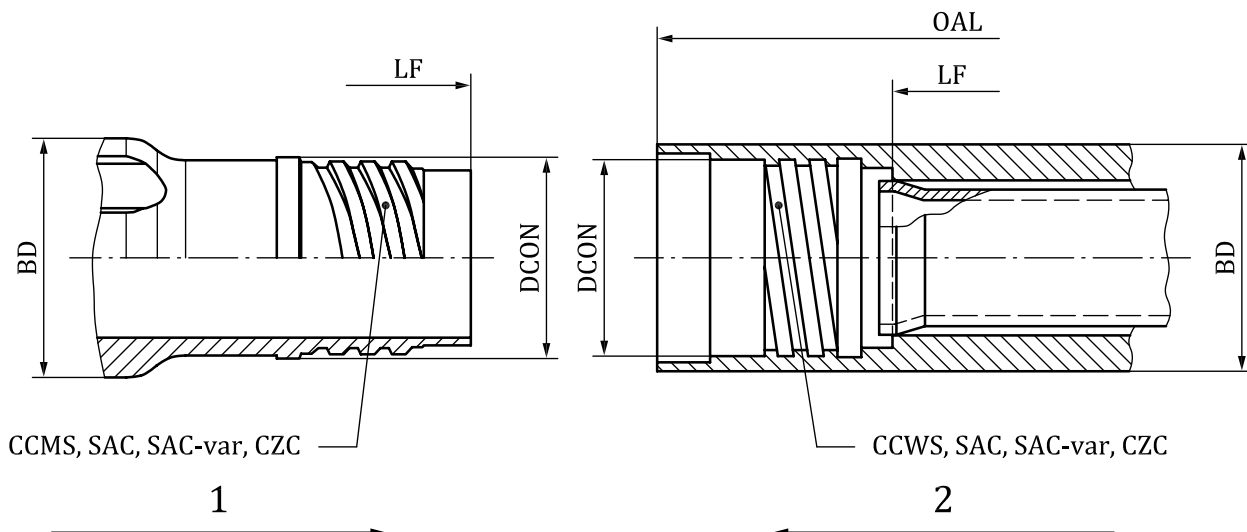

Key

- 1 machine side connection
- 2 workpiece side connection

Figure E.51 — SAC screw-on adaptor connection Coromant

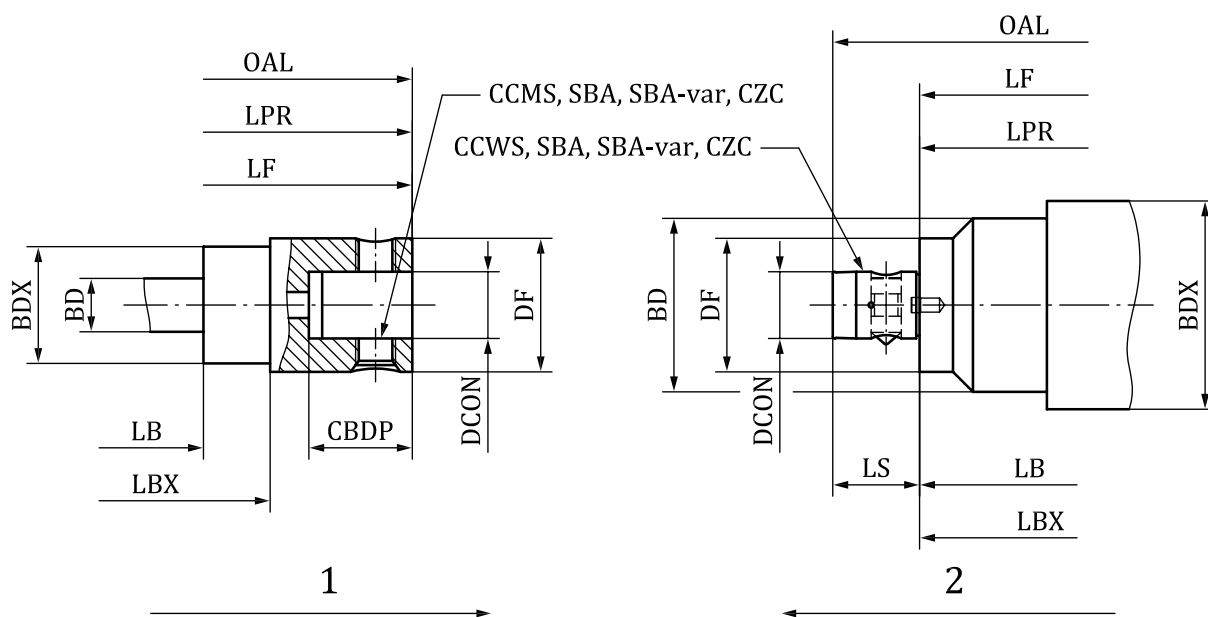

Key

- 1 machine side connection
- 2 workpiece side connection

Figure E.52 — SBA SBA-system Komet

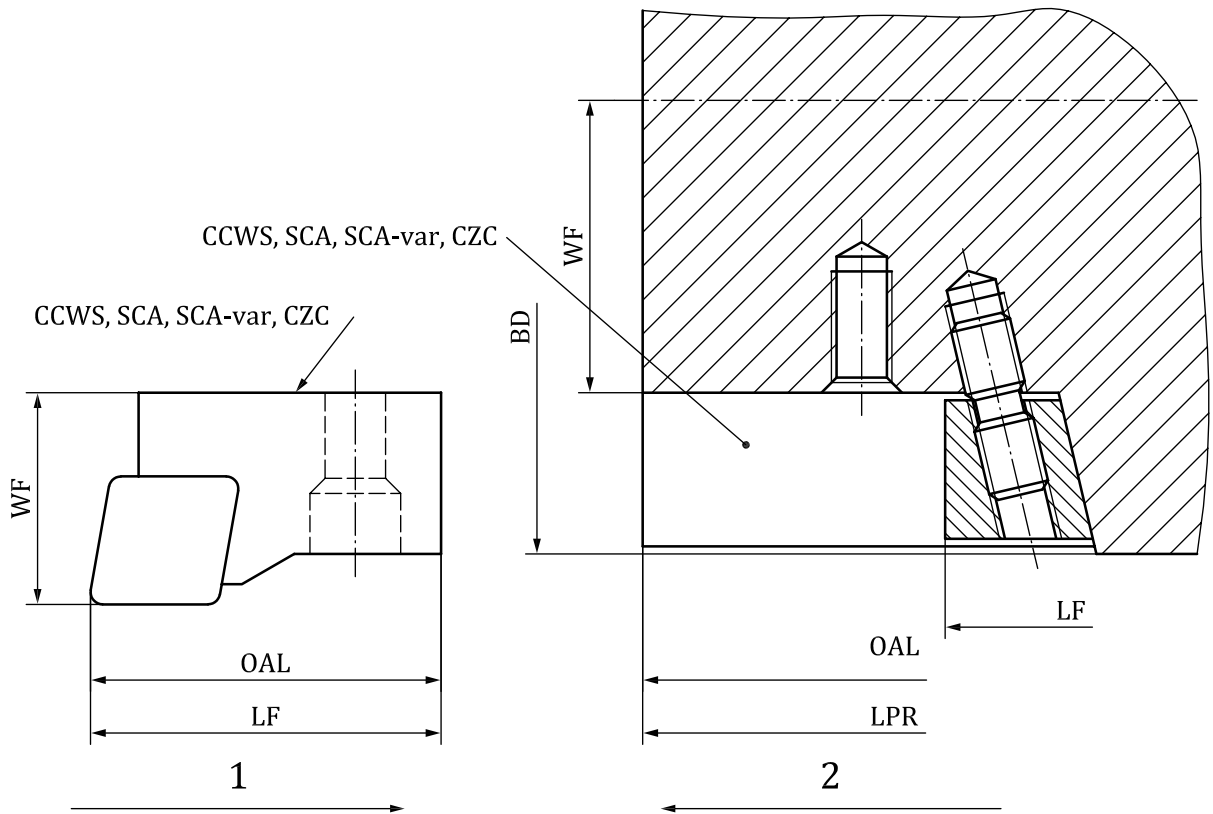

Key

- 1 machine side connection
- 2 workpiece side connection

Figure E.53 — SCA SECO cartridge mounting

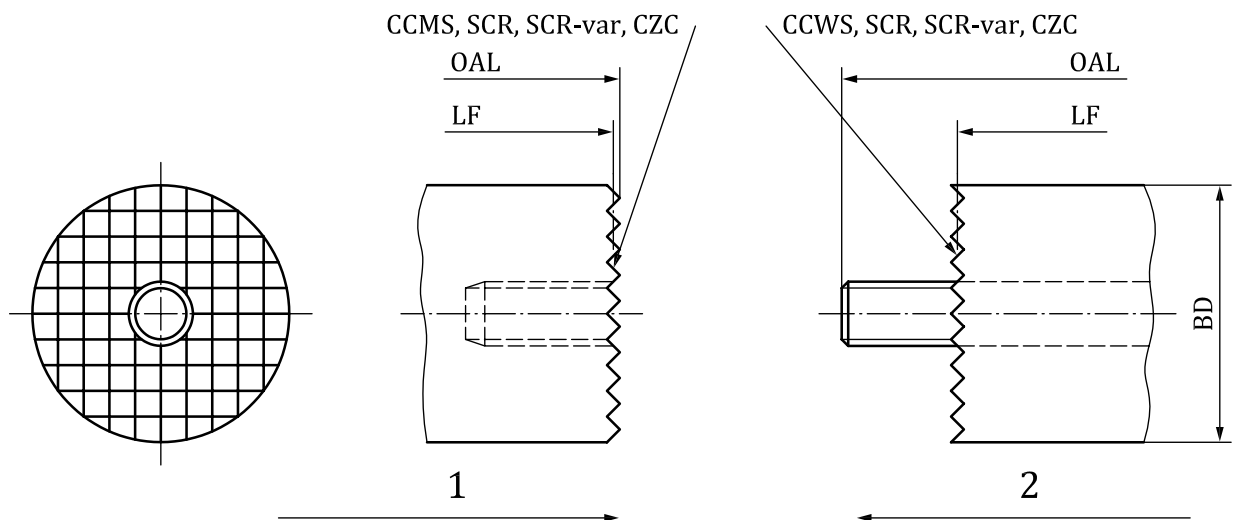

Key

- 1 machine side connection
- 2 workpiece side connection

Figure E.54 — SCR SECO crown lock connection

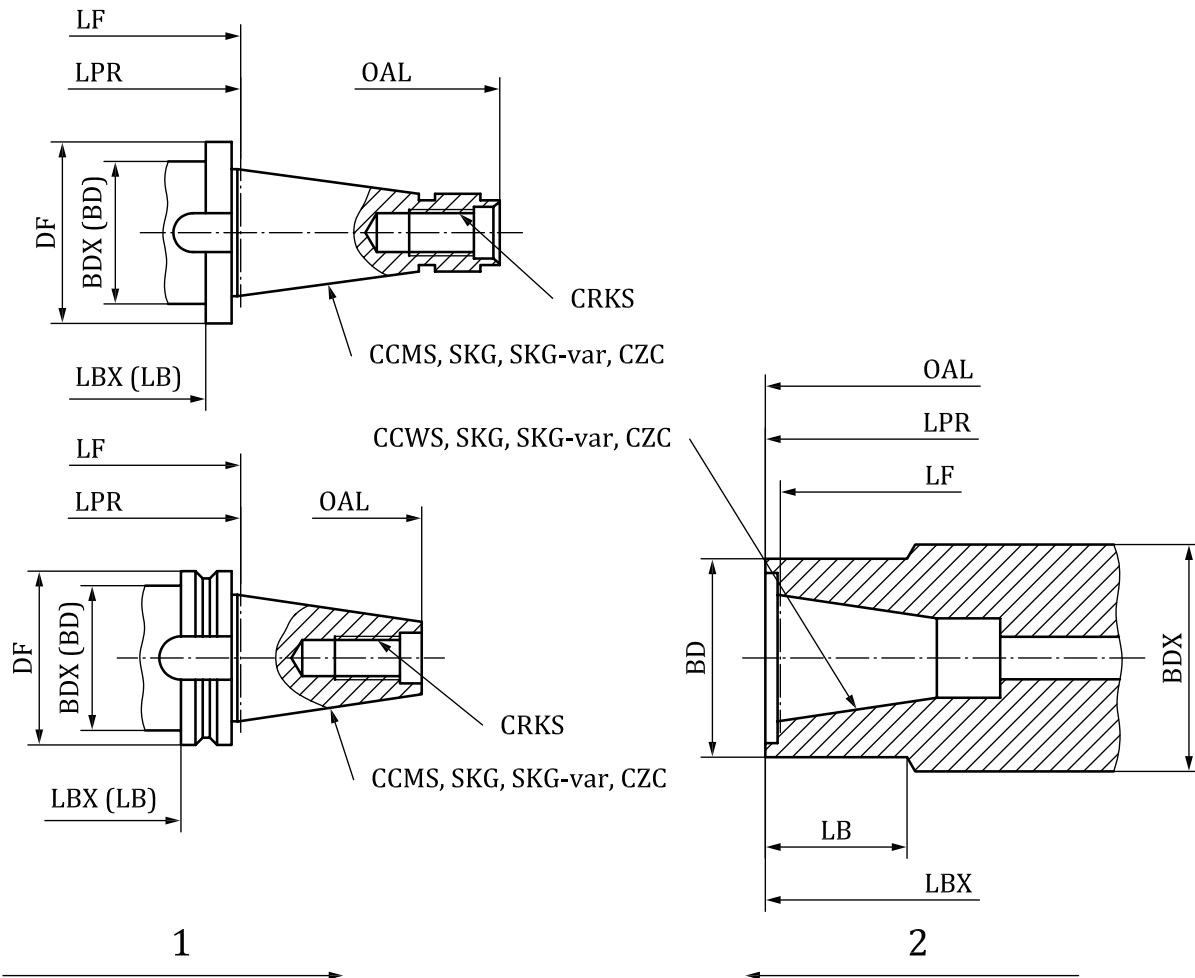

- Key**
- 1 machine side connection
 - 2 workpiece side connection

Figure E.55 — SKG Steep taper

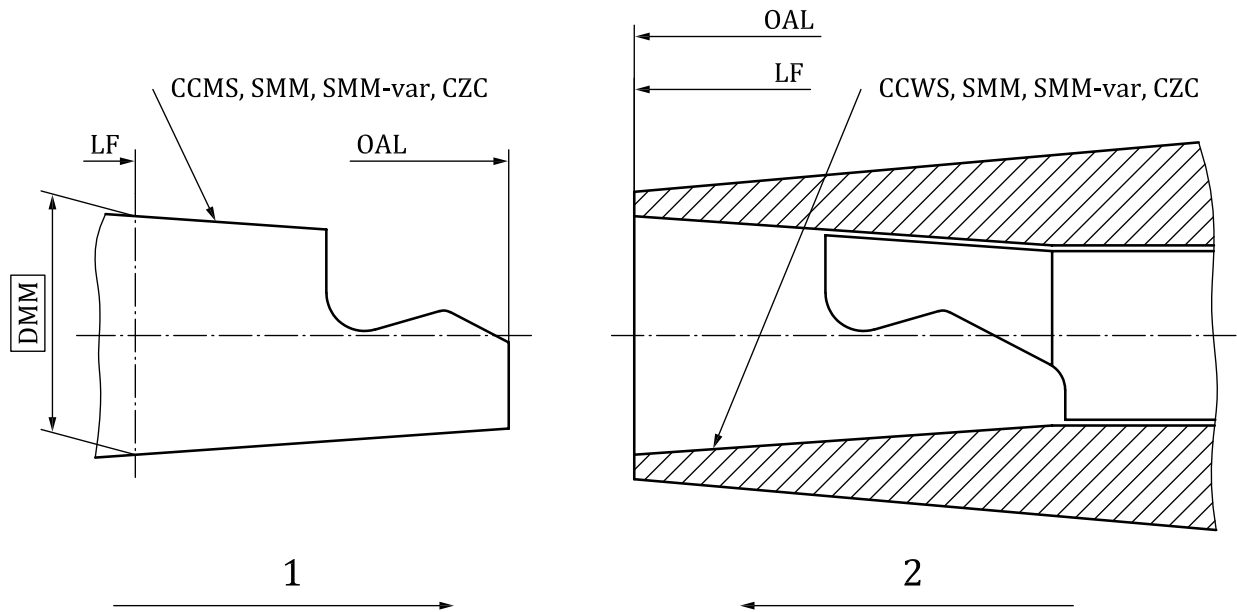

Key

- 1 machine side connection
- 2 workpiece side connection

Figure E.56 — SMM SECO minimaster

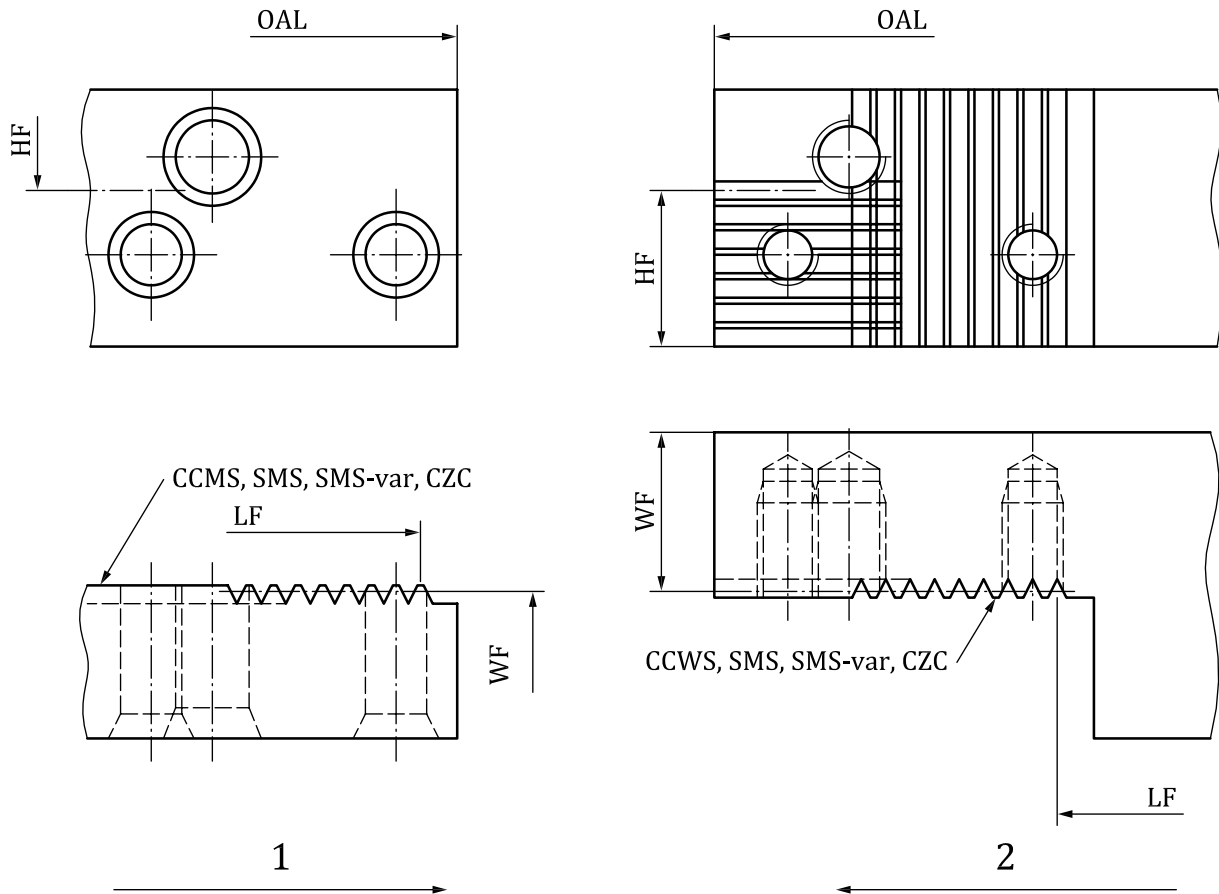

Key

- 1 machine side connection
- 2 workpiece side connection

Figure E.57 — SMS SECO modular serrated connection

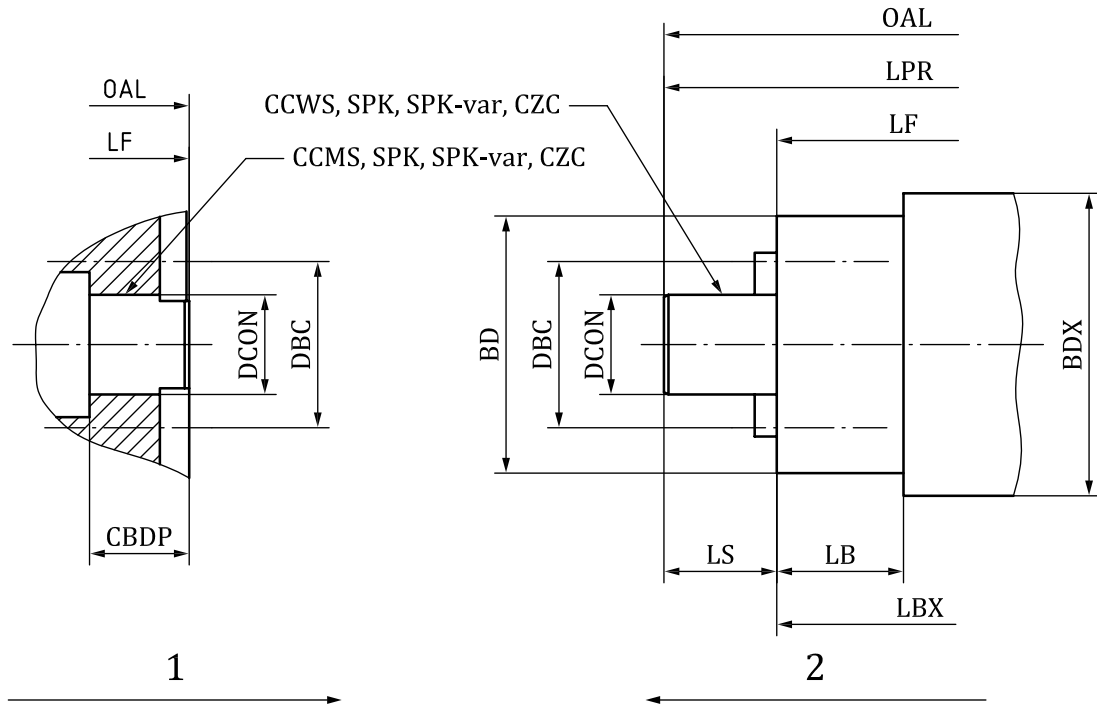

Key

- 1 machine side connection
- 2 workpiece side connection

Figure E.58 — SPK holding arbor

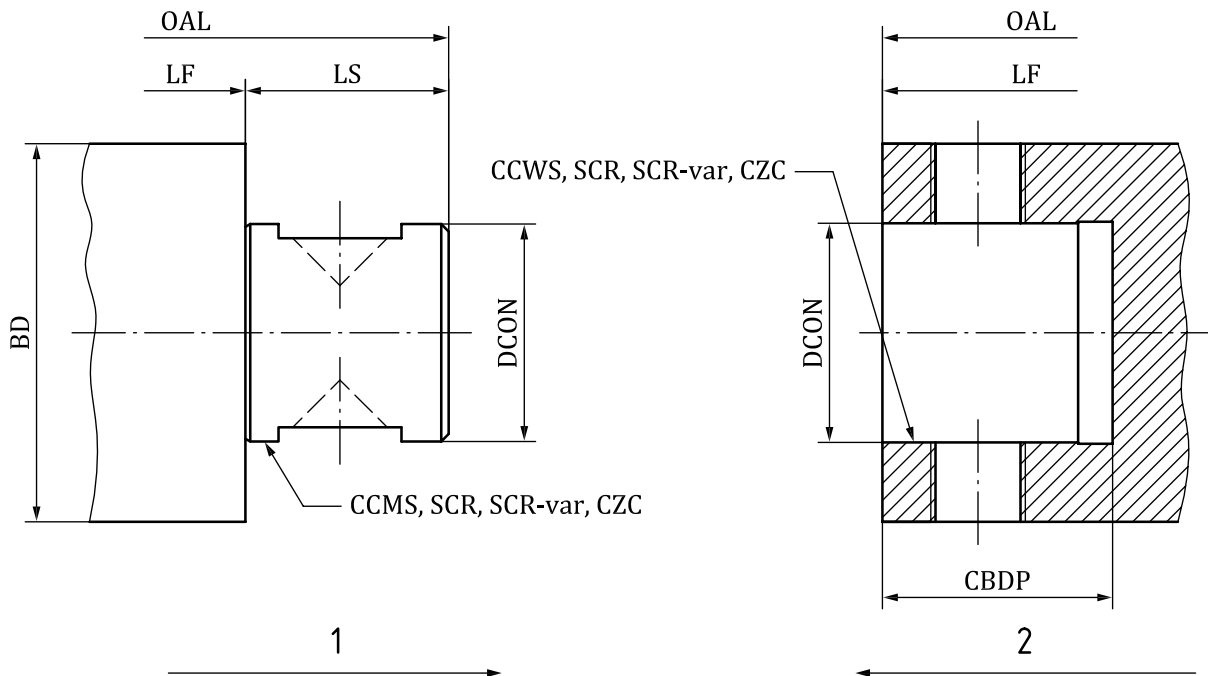

Key

- 1 machine side connection
- 2 workpiece side connection

Figure E.59 — SRT SECO R2 shank

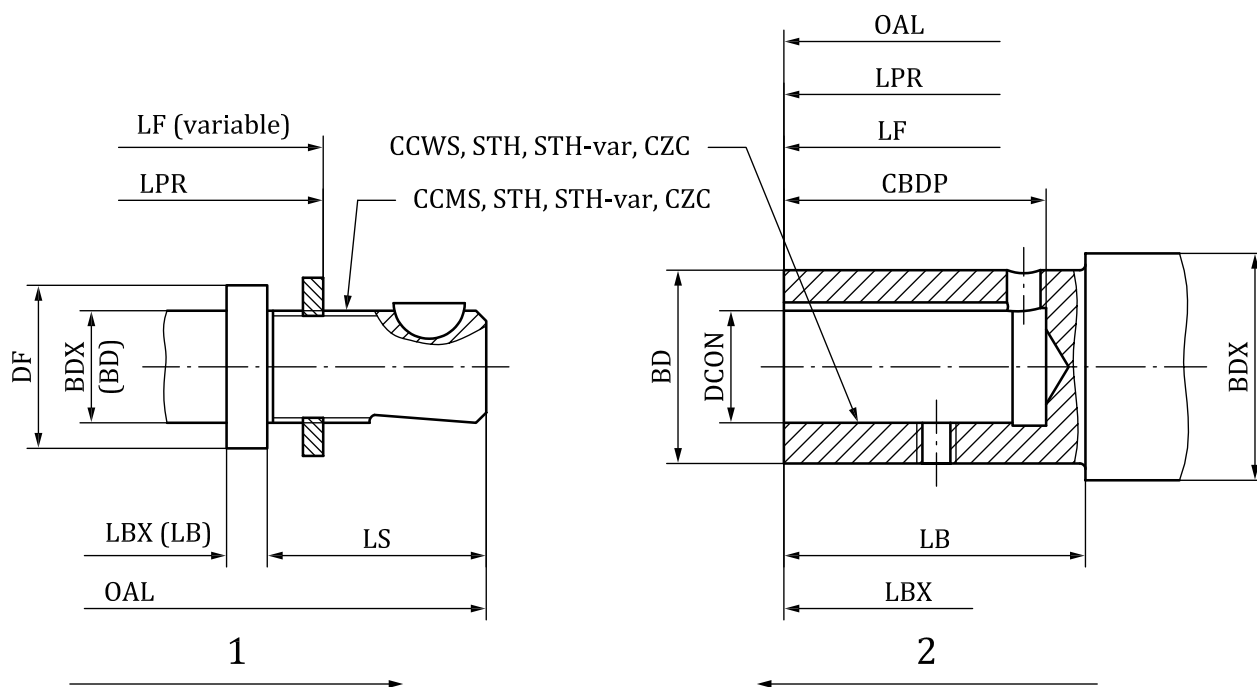

Key

- 1 machine side connection
- 2 workpiece side connection

Figure E.60 — STH automotive shank

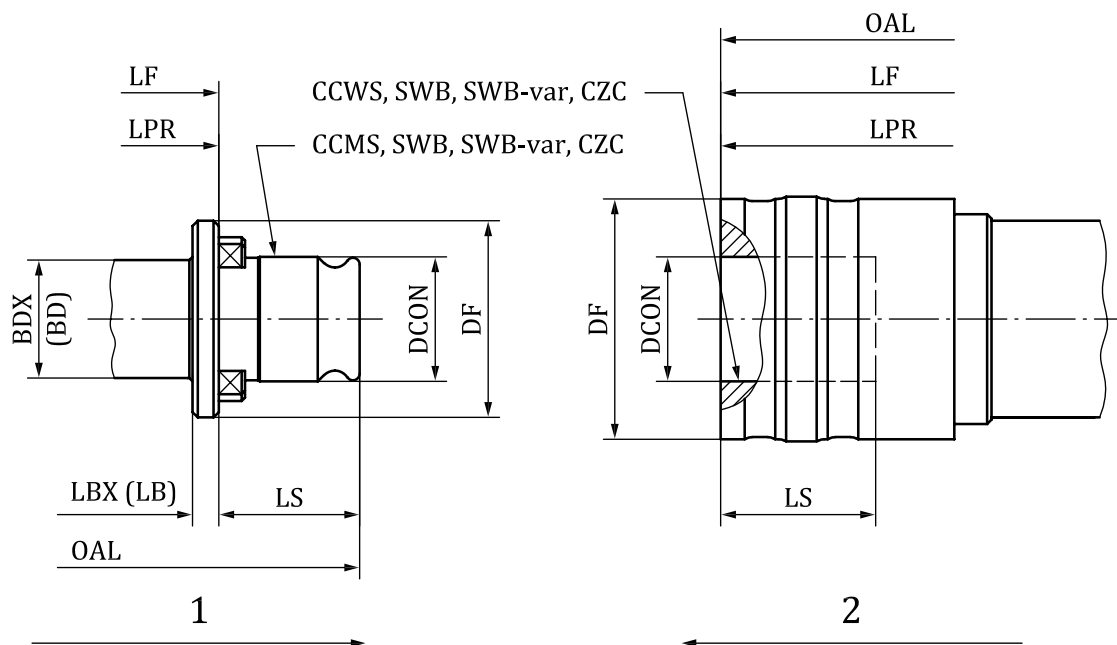

Key

- 1 machine side connection
- 2 workpiece side connection

Figure E.61 — SWB quick change connection

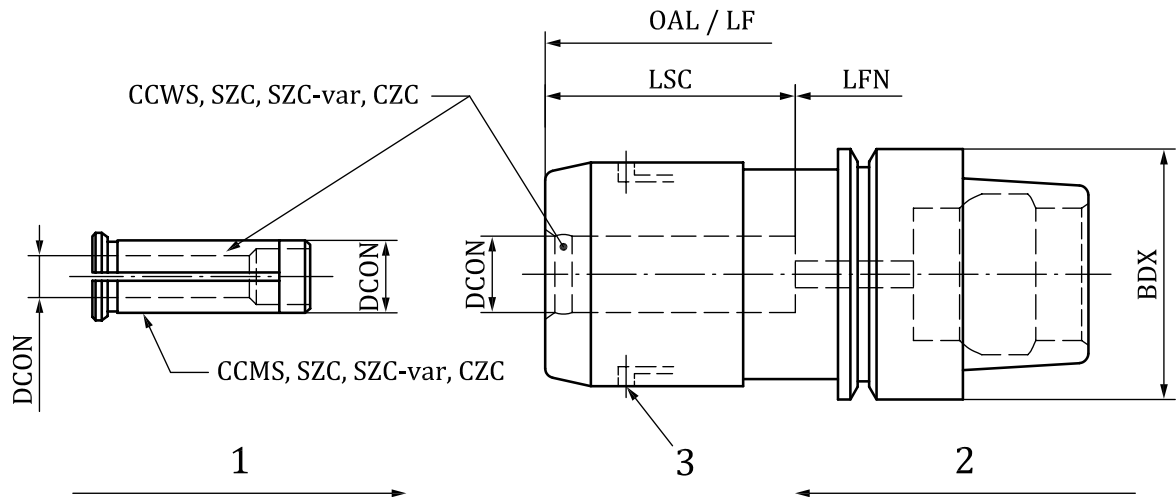

Key

- 1 machine side connection
- 2 workpiece side connection

Figure E.62 — variant 01 of SZC collet connection Coromant

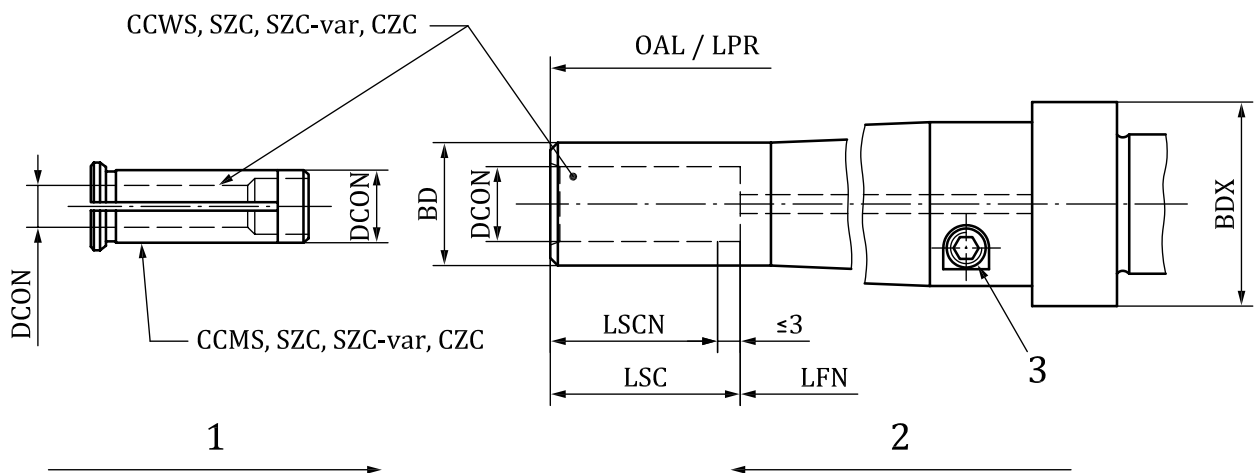

Key

- 1 machine side connection
- 2 workpiece side connection

Figure E.63 — Variant 02 of SZC collet connection Coromant

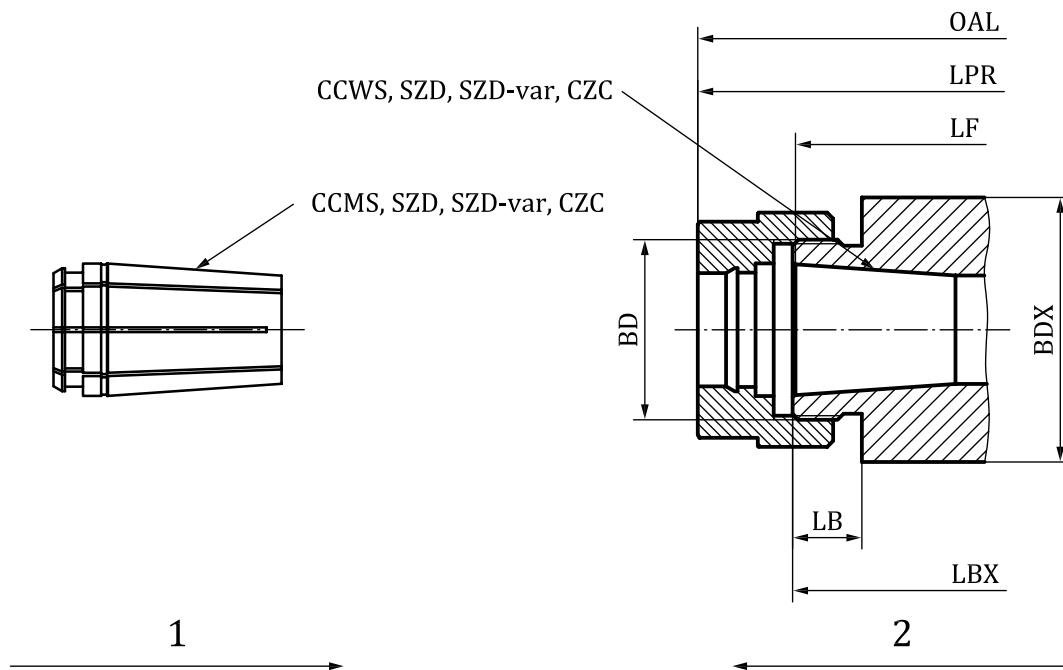

- Key**
- 1 machine side connection
 - 2 workpiece side connection

Figure E.64 — SZD collet connection standard

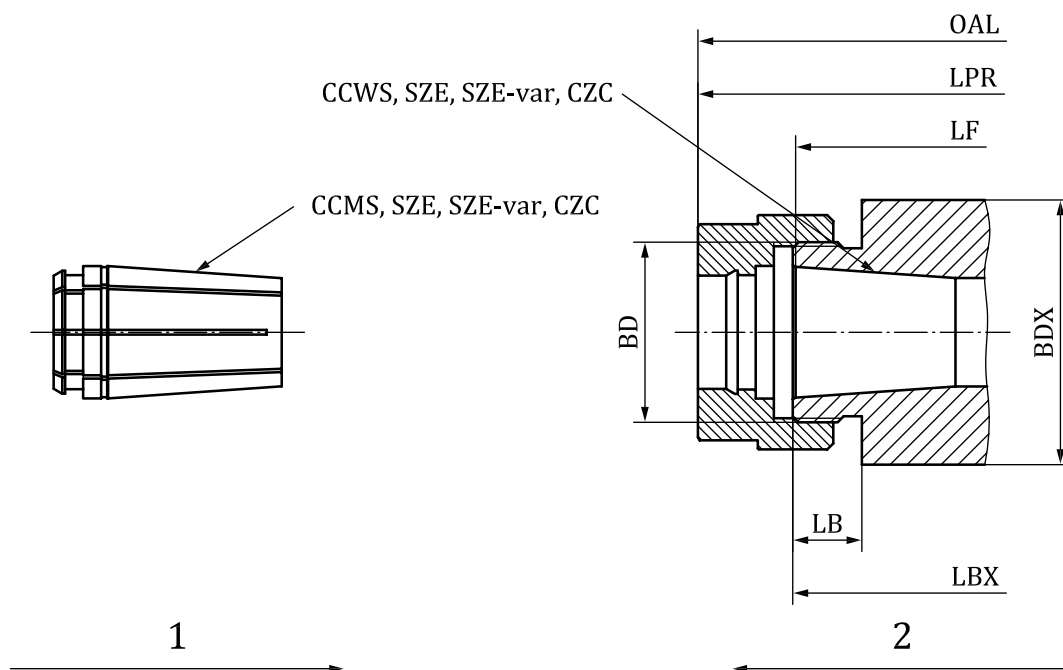

- Key**
- 1 machine side connection
 - 2 workpiece side connection

Figure E.65 — SZE collet connection Erikson

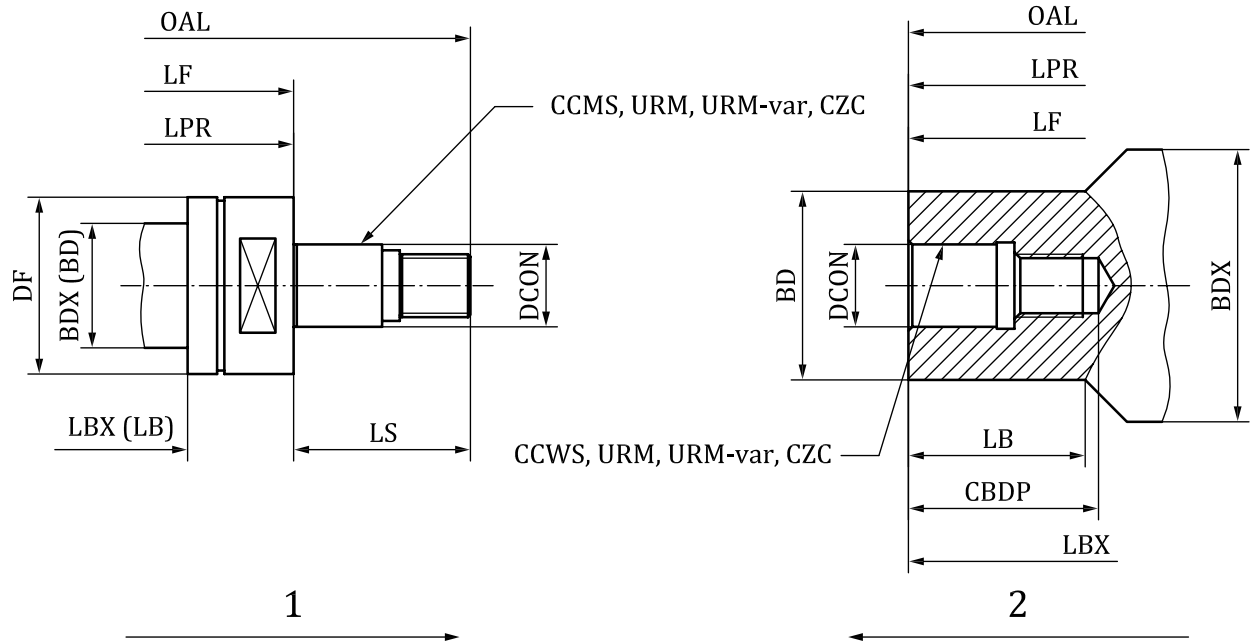

Key

- 1 machine side connection
- 2 workpiece side connection

Figure E.66 — URM Urma connection

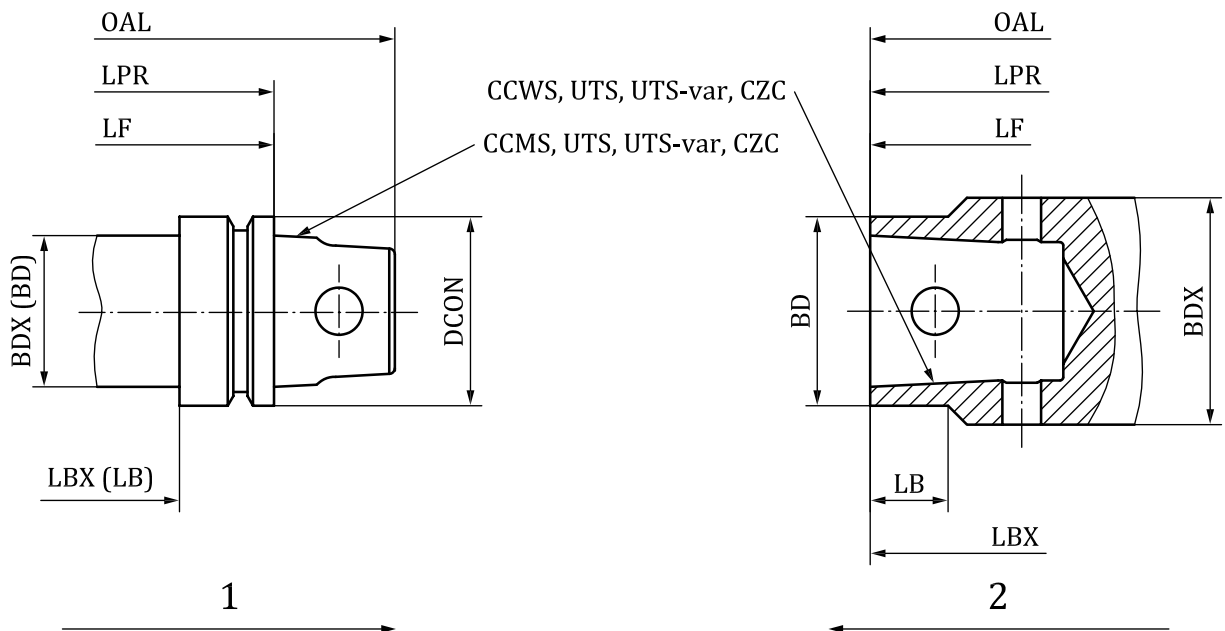

Key

- 1 machine side connection
- 2 workpiece side connection

Figure E.67 — UTS UTS Widia

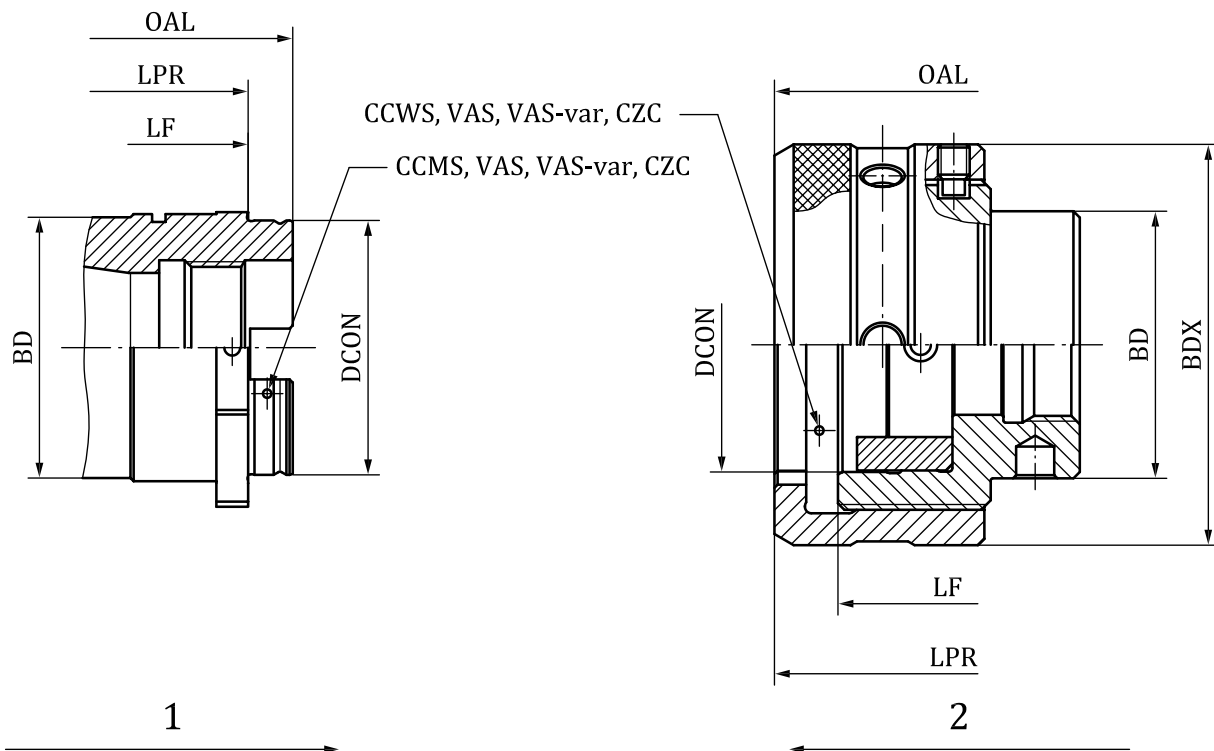

- Key**
- 1 machine side connection
 - 2 workpiece side connection

Figure E.68 — VAS Variant System Coromant

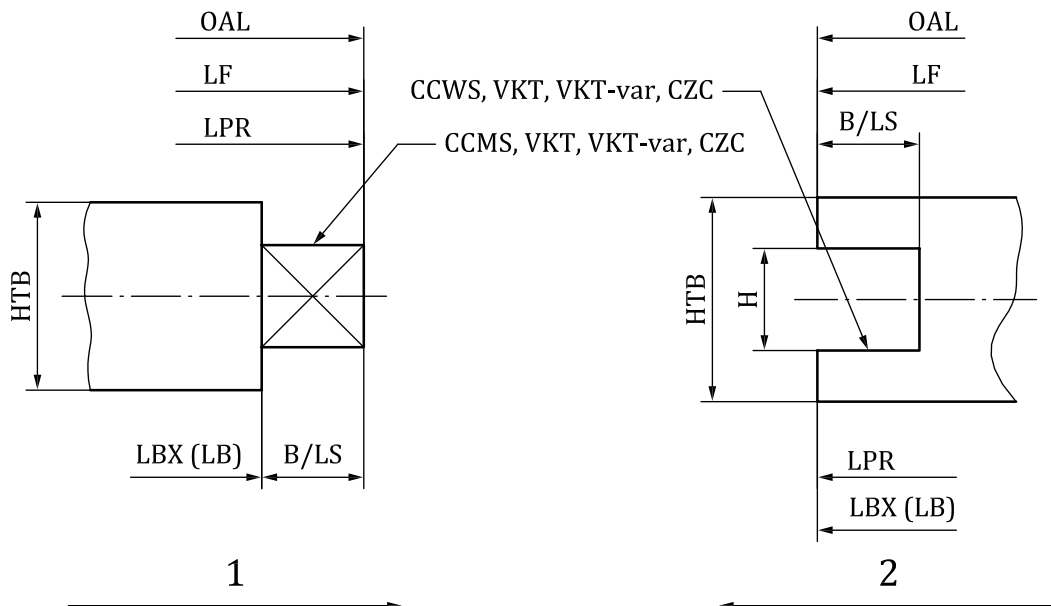

- Key**
- 1 machine side connection
 - 2 workpiece side connection

Figure E.69 — VKT rectangular connection

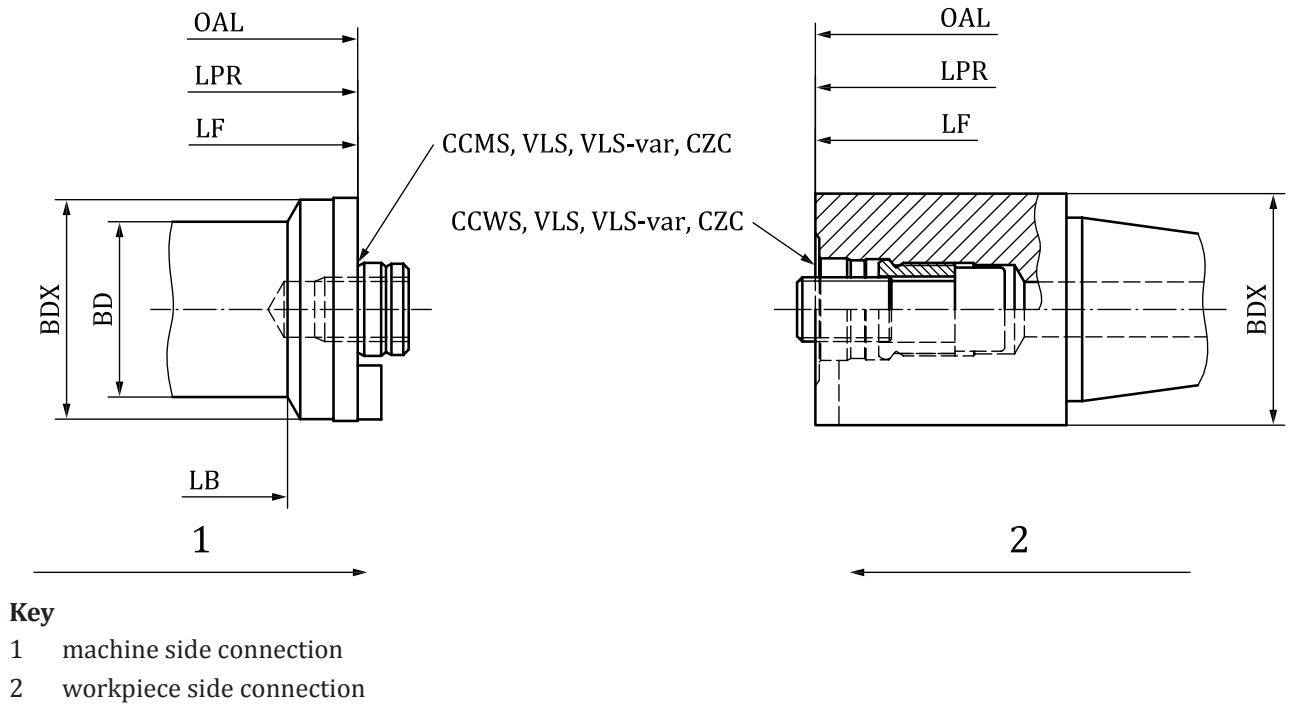
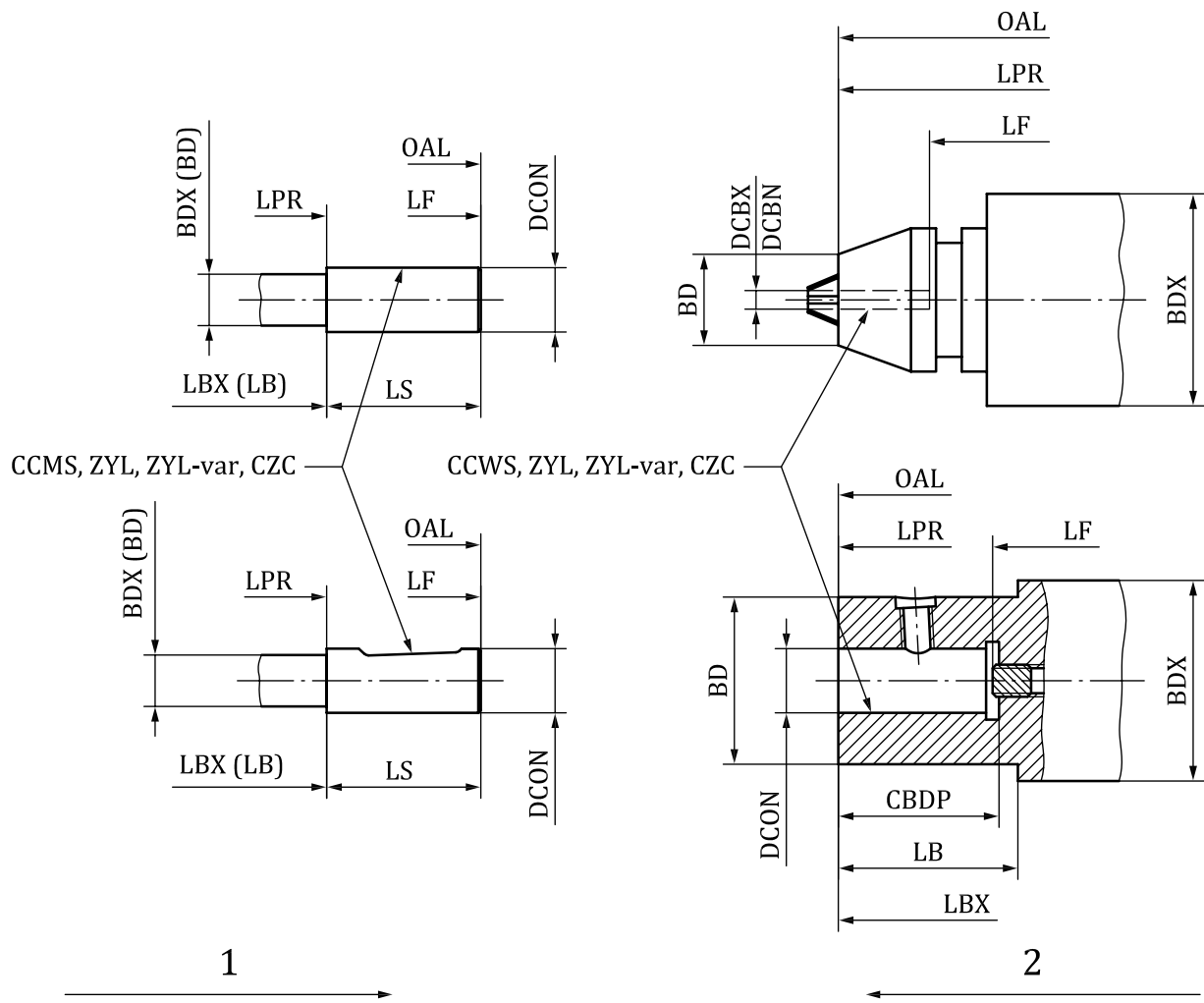

Figure E.70 — VLS Varilock System Coromant



Key

- 1 machine side connection
- 2 workpiece side connection

Figure E.71 — ZYL cylindrical shank connection

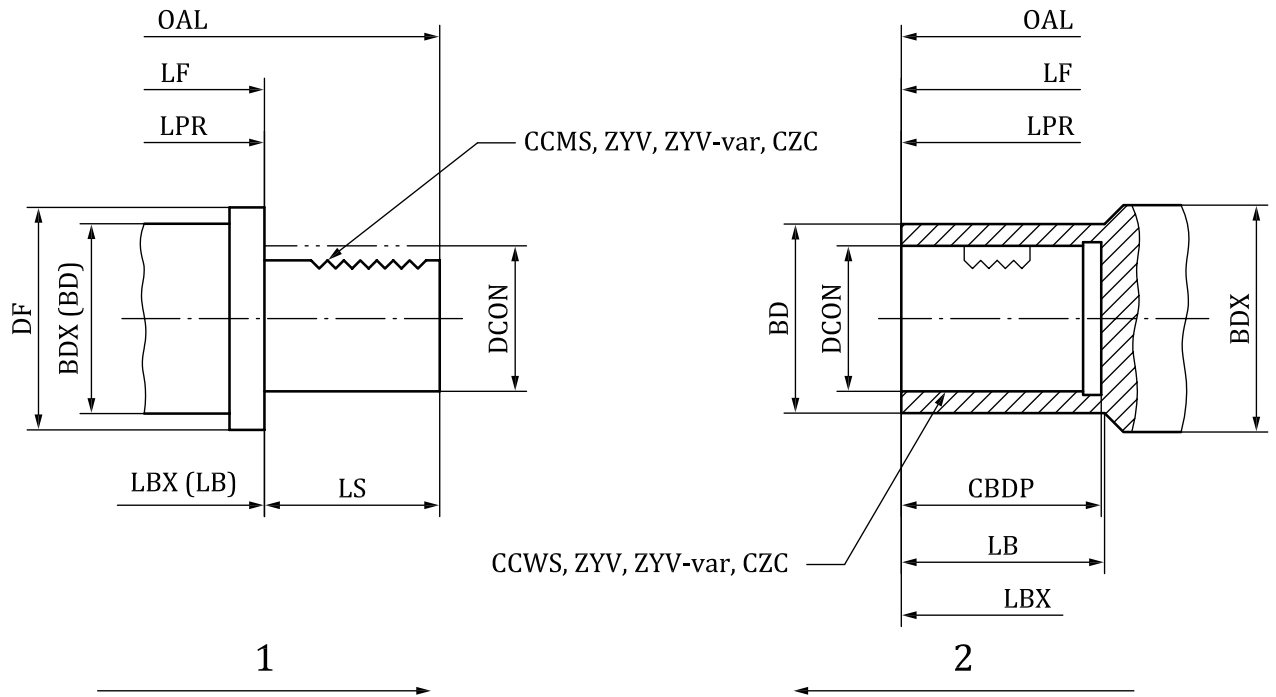

Key

- 1 machine side connection
- 2 workpiece side connection

Figure E.72 — ZYV VDI shank

Bibliography

- [1] ISO 3002-1:1982, *Basic quantities in cutting and grinding — Part 1: Geometry of the active part of cutting tools — General terms, reference systems, tool and working angles, chip breakers*
- [2] ISO 10303-1:1994, *Industrial automation systems and integration — Product data representation and exchange — Part 1: Overview and fundamental principles*
- [3] ISO 10303-11:2004, *Industrial automation systems and integration — Product data representation and exchange — Part 11: Description methods: The EXPRESS language reference manual*
- [4] ISO 10303-21, *Industrial automation systems and integration — Product data representation and exchange — Part 21: Implementation methods: Clear text encoding of the exchange structure*
- [5] ISO/TS 10303-421, *Industrial automation systems and integration — Product data representation and exchange — Part 421: Application module: Functional data and schematic representation*
- [6] ISO/TS 13399-2:2014, *Cutting tool data representation and exchange — Part 2: Reference dictionary for the cutting items*
- [7] ISO/TS 13399-50:2013, *Cutting tool data representation and exchange — Part 50: Reference dictionary for reference systems and common concepts*
- [8] ISO 13584-24:2003, *Industrial automation systems and integration — Parts library — Part 24: Logical resource: Logical model of supplier library*
- [9] ISO 13584-25, *Industrial automation systems and integration — Parts library — Part 25: Logical resource: Logical model of supplier library with aggregate values and explicit content*
- [10] ISO 13584-42:2010, *Industrial automation systems and integration — Parts library — Part 42: Description methodology: Methodology for structuring parts families*
- [11] ISO 13584-511:2006, *Industrial automation systems and integration — Parts library — Part 511: Mechanical systems and components for general use — Reference dictionary for fasteners*

British Standards Institution (BSI)

BSI is the national body responsible for preparing British Standards and other standards-related publications, information and services.

BSI is incorporated by Royal Charter. British Standards and other standardization products are published by BSI Standards Limited.

About us

We bring together business, industry, government, consumers, innovators and others to shape their combined experience and expertise into standards-based solutions.

The knowledge embodied in our standards has been carefully assembled in a dependable format and refined through our open consultation process. Organizations of all sizes and across all sectors choose standards to help them achieve their goals.

Information on standards

We can provide you with the knowledge that your organization needs to succeed. Find out more about British Standards by visiting our website at bsigroup.com/standards or contacting our Customer Services team or Knowledge Centre.

Buying standards

You can buy and download PDF versions of BSI publications, including British and adopted European and international standards, through our website at bsigroup.com/shop, where hard copies can also be purchased.

If you need international and foreign standards from other Standards Development Organizations, hard copies can be ordered from our Customer Services team.

Subscriptions

Our range of subscription services are designed to make using standards easier for you. For further information on our subscription products go to bsigroup.com/subscriptions.

With **British Standards Online (BSOL)** you'll have instant access to over 55,000 British and adopted European and international standards from your desktop. It's available 24/7 and is refreshed daily so you'll always be up to date.

You can keep in touch with standards developments and receive substantial discounts on the purchase price of standards, both in single copy and subscription format, by becoming a **BSI Subscribing Member**.

PLUS is an updating service exclusive to BSI Subscribing Members. You will automatically receive the latest hard copy of your standards when they're revised or replaced.

To find out more about becoming a BSI Subscribing Member and the benefits of membership, please visit bsigroup.com/shop.

With a **Multi-User Network Licence (MUNL)** you are able to host standards publications on your intranet. Licences can cover as few or as many users as you wish. With updates supplied as soon as they're available, you can be sure your documentation is current. For further information, email bsmusales@bsigroup.com.

BSI Group Headquarters

389 Chiswick High Road London W4 4AL UK

Revisions

Our British Standards and other publications are updated by amendment or revision.

We continually improve the quality of our products and services to benefit your business. If you find an inaccuracy or ambiguity within a British Standard or other BSI publication please inform the Knowledge Centre.

Copyright

All the data, software and documentation set out in all British Standards and other BSI publications are the property of and copyrighted by BSI, or some person or entity that owns copyright in the information used (such as the international standardization bodies) and has formally licensed such information to BSI for commercial publication and use. Except as permitted under the Copyright, Designs and Patents Act 1988 no extract may be reproduced, stored in a retrieval system or transmitted in any form or by any means – electronic, photocopying, recording or otherwise – without prior written permission from BSI. Details and advice can be obtained from the Copyright & Licensing Department.

Useful Contacts:

Customer Services

Tel: +44 845 086 9001

Email (orders): orders@bsigroup.com

Email (enquiries): cservices@bsigroup.com

Subscriptions

Tel: +44 845 086 9001

Email: subscriptions@bsigroup.com

Knowledge Centre

Tel: +44 20 8996 7004

Email: knowledgecentre@bsigroup.com

Copyright & Licensing

Tel: +44 20 8996 7070

Email: copyright@bsigroup.com



...making excellence a habit.™