

PD ISO/TS 13399-307:2016



BSI Standards Publication

Cutting tool data representation and exchange

Part 307: Creation and exchange of 3D
models — End mills for indexable inserts

bsi.

...making excellence a habit.™

National foreword

This Published Document is the UK implementation of ISO/TS 13399-307:2016.

The UK participation in its preparation was entrusted to Technical Committee MTE/18, Tools tips and inserts for cutting applications.

A list of organizations represented on this committee can be obtained on request to its secretary.

This publication does not purport to include all the necessary provisions of a contract. Users are responsible for its correct application.

© The British Standards Institution 2016. Published by BSI Standards Limited 2016

ISBN 978 0 580 89399 5

ICS 25.100.01; 35.240.50

Compliance with a British Standard cannot confer immunity from legal obligations.

This Published Document was published under the authority of the Standards Policy and Strategy Committee on 29 February 2016.

Amendments issued since publication

Date	Text affected
------	---------------

First edition
2016-02-15

**Cutting tool data representation and
exchange —**

Part 307:

**Creation and exchange of 3D models
— End mills for indexable inserts**

Représentation et échange des données relatives aux outils coupants —

*Partie 307: Création et échange des modèles 3D — Fraises à
plaquettes amovibles*



Reference number
ISO/TS 13399-307:2016(E)

© ISO 2016



COPYRIGHT PROTECTED DOCUMENT

© ISO 2016, Published in Switzerland

All rights reserved. Unless otherwise specified, no part of this publication may be reproduced or utilized otherwise in any form or by any means, electronic or mechanical, including photocopying, or posting on the internet or an intranet, without prior written permission. Permission can be requested from either ISO at the address below or ISO's member body in the country of the requester.

ISO copyright office
Ch. de Blandonnet 8 • CP 401
CH-1214 Vernier, Geneva, Switzerland
Tel. +41 22 749 01 11
Fax +41 22 749 09 47
copyright@iso.org
www.iso.org

Contents

Page

Foreword	vi
Introduction	viii
1 Scope	1
2 Normative references	1
3 Starting elements, coordinate systems, planes	2
3.1 General.....	2
3.2 Reference system.....	2
3.3 Coordinate system at the cutting part.....	3
3.4 Planes.....	4
3.5 Design of the pocket seat and cutting reference point (CRP) of the insert.....	5
3.6 Adjustment coordinate system on workpiece side.....	8
3.6.1 General.....	8
3.6.2 Designation of the coordinate system workpiece side.....	8
4 Design of the model	9
4.1 General.....	9
4.2 Necessary parameters for the connection interface feature.....	9
4.3 Necessary properties for inserts.....	10
4.3.1 General.....	10
4.3.2 Properties for equilateral, equiangular and equilateral, non- equiangular inserts.....	10
4.3.3 Properties for non-equilateral, equiangular and non-equilateral, non- equiangular inserts.....	11
4.3.4 Design of the pocket seat feature.....	11
5 End mill, non-centre cutting, single row	11
5.1 General.....	11
5.2 Necessary properties.....	12
5.3 Basic geometry.....	13
5.4 Determination of the position of the mounting coordinate system of insert.....	13
5.5 Chip flute and pocket seat.....	14
5.6 Assembly of a single row, non-centre cutting end mill.....	15
6 Single row, non-centre cutting V-groove end mill	16
6.1 General.....	16
6.2 Necessary properties.....	17
6.3 Basic geometry.....	17
6.4 Determination of the position of the mounting coordinate system of insert.....	17
6.5 Chip flute and pocket seat.....	18
6.6 Single row, non-centre cutting V-groove end mill assembly.....	19
7 Single row, non-centre-cutting dovetail end mill	20
7.1 General.....	20
7.2 Necessary properties.....	20
7.3 Basic geometry.....	21
7.4 Determination of the position of the mounting coordinate system of insert.....	21
7.5 Chip flute and pocket seat.....	21
7.6 Single row, non-centre-cutting dovetail end mill assembly.....	22
8 T-slot end mill	22
8.1 General.....	22
8.2 Necessary properties.....	23
8.3 Basic geometry.....	23
8.4 Determination of the position of the mounting coordinate system of insert.....	23
8.5 Chip flute and pocket seat.....	24
8.6 Assembly of a T-slot end mill.....	25

9	Single row, rounded end mill	26
9.1	General.....	26
9.2	Necessary properties.....	27
9.3	Basic geometry.....	27
9.4	Determination of the position of the mounting coordinate system of insert.....	28
9.5	Chip flute and pocket seat.....	28
9.6	Assembly of a rounded end mill.....	30
10	Threading end mill	30
10.1	General.....	30
10.2	Necessary properties.....	31
10.3	Basic geometry.....	32
10.4	Determination of the position of the mounting coordinate system of insert.....	32
10.5	Chip flute and pocket seat.....	33
10.6	Assembled threading end mill.....	34
11	End mill, non-centre-cutting, multiple rows	35
11.1	General.....	35
11.2	Necessary properties.....	35
11.3	Basic geometry.....	36
11.4	Determination of the position of the mounting coordinate system of insert.....	36
11.5	Chip flute and pocket seat.....	38
11.6	Multiple rows, non-centre-cutting end mill assembly.....	39
12	Angular end mill, non-centre-cutting, multiple rows	40
12.1	General.....	40
12.2	Necessary properties.....	40
12.3	Basic geometry.....	41
12.4	Determination of the position of the mounting coordinate system of insert.....	41
12.5	Chip flute and pocket seat.....	41
12.6	Multiple rows non-centre-cutting angular end mill assembly.....	42
13	End mill, centre-cutting, multiple rows	42
13.1	General.....	42
13.2	Necessary properties.....	43
13.3	Basic geometry.....	43
13.4	Determination of the position of the mounting coordinate system of insert.....	43
13.5	Chip flute and pocket seat.....	44
13.6	Multiple rows, centre-cutting angular end mill assembly.....	45
14	Spot-facing end mill	46
14.1	General.....	46
14.2	Necessary properties.....	46
14.3	Basic geometry.....	47
14.4	Determination of the position of the mounting coordinate system of insert.....	47
14.5	Chip flute and pocket seat.....	47
14.6	Assembled spot-facing end mill.....	49
15	Straight ball-nosed end mill	49
15.1	General.....	49
15.2	Necessary properties.....	50
15.3	Basic geometry.....	50
15.4	Determination of the position of the mounting coordinate system of insert.....	51
15.5	Chip flute and pocket seat.....	52
15.6	Straight ball-nosed end mill assembly.....	53
16	Angular ball-nosed end mill	53
16.1	General.....	53
16.2	Necessary properties.....	54
16.3	Basic geometry.....	54
16.4	Determination of the position of the mounting coordinate system of insert.....	54
16.5	Chip flute and pocket seat.....	54

16.6	Angular ball-nosed end mill assembly	54
17	Die and mould end mill	54
17.1	General	54
17.2	Necessary properties	55
17.3	Basic geometry	56
17.4	Determination of the position of the mounting coordinate system of insert	56
17.5	Chip flute and pocket seat	56
17.6	Die end mill assembly	58
18	Bell-style end mill	58
18.1	General	58
18.2	Necessary properties	59
18.3	Basic geometry	60
18.4	Determination of the position of the mounting coordinate system of insert	60
18.5	Chip flute and pocket seat	61
18.6	Bell-style end mill assembly	61
19	Design of details	61
19.1	Basis for modelling	61
19.2	Fixing threads for inserts	62
19.3	Contact/clamping surfaces — Orientation	62
19.4	Chamfers and roundings	62
20	Attributes of surfaces — Visualization of the model features	62
21	Structure of the design elements (tree of model)	62
22	Data exchange model	63
Annex A (informative) Information about nominal dimensions		65
Bibliography		66

Foreword

ISO (the International Organization for Standardization) is a worldwide federation of national standards bodies (ISO member bodies). The work of preparing International Standards is normally carried out through ISO technical committees. Each member body interested in a subject for which a technical committee has been established has the right to be represented on that committee. International organizations, governmental and non-governmental, in liaison with ISO, also take part in the work. ISO collaborates closely with the International Electrotechnical Commission (IEC) on all matters of electrotechnical standardization.

The procedures used to develop this document and those intended for its further maintenance are described in the ISO/IEC Directives, Part 1. In particular the different approval criteria needed for the different types of ISO documents should be noted. This document was drafted in accordance with the editorial rules of the ISO/IEC Directives, Part 2 (see www.iso.org/directives).

Attention is drawn to the possibility that some of the elements of this document may be the subject of patent rights. ISO shall not be held responsible for identifying any or all such patent rights. Details of any patent rights identified during the development of the document will be in the Introduction and/or on the ISO list of patent declarations received (see www.iso.org/patents).

Any trade name used in this document is information given for the convenience of users and does not constitute an endorsement.

For an explanation on the meaning of ISO specific terms and expressions related to conformity assessment, as well as information about ISO's adherence to the WTO principles in the Technical Barriers to Trade (TBT), see the following URL: [Foreword — Supplementary information](#).

The committee responsible for this document is ISO/TC 29, *Small tools*.

ISO/TS 13399 consists of the following parts, under the general title *Cutting tool data representation and exchange*:

- *Part 1: Overview, fundamental principles and general information model*
- *Part 2: Reference dictionary for the cutting items* [Technical Specification]
- *Part 3: Reference dictionary for tool items* [Technical Specification]
- *Part 4: Reference dictionary for adaptive items* [Technical Specification]
- *Part 5: Reference dictionary for assembly items* [Technical Specification]
- *Part 50: Reference dictionary for reference systems and common concepts* [Technical Specification]
- *Part 60: Reference dictionary for connection systems* [Technical Specification]
- *Part 80: Creation and exchange of 3D models — Overview and principles* [Technical Specification]
- *Part 100: Definitions, principles and methods for reference dictionaries* [Technical Specification]
- *Part 150: Usage guidelines* [Technical Specification]
- *Part 201: Creation and exchange of 3D models — Regular inserts* [Technical Specification]
- *Part 202: Creation and exchange of 3D models — Irregular inserts* [Technical Specification]
- *Part 203: Creation and exchange of 3D models — Replaceable inserts for drilling* [Technical Specification]
- *Part 204: Creation and exchange of 3D models — Inserts for reaming* [Technical Specification]
- *Part 301: Concept for the design of 3D models based on properties according to ISO/TS 13399-3: Modelling of thread-cutting taps, thread-forming taps and thread-cutting dies* [Technical Specification]

- *Part 302: Concept for the design of 3D models based on properties according to ISO/TS 13399-3: Modelling of solid drills and countersinking tools* [Technical Specification]
- *Part 303: Concept for the design of 3D models based on properties according to ISO/TS 13399-3: Modelling of end mills with solid cutting edges* [Technical Specification]
- *Part 304: Concept for the design of 3D models based on properties according to ISO/TS 13399-3: Modelling of milling cutters with arbor hole and solid cutting edges* [Technical Specification]
- *Part 307: Creation and exchange of 3D models — End mills for indexable inserts* [Technical Specification]
- *Part 308: Creation and exchange of 3D models — Milling cutters with arbor hole for indexable inserts* [Technical Specification]
- *Part 309: Creation and exchange of 3D models — Tool holders for indexable inserts* [Technical Specification]
- *Part 311: Creation and exchange of 3D models — Solid reamers* [Technical Specification]
- *Part 312: Creation and exchange of 3D models — Reamers for indexable inserts* [Technical Specification]
- *Part 401: Creation and exchange of 3D models — Converting, extending and reducing adaptive items* [Technical Specification]
- *Part 405: Creation and exchange of 3D models — Collets* [Technical Specification]

The following parts are under preparation:

- *Part 70: Graphical data layout — Layer settings for tool designs* [Technical Specification]
- *Part 71: Graphical data layout — Creation of documents for the standardized data exchange — Graphical product information* [Technical Specification]
- *Part 72: Creation of documents for the standardized data exchange — Definition of properties for drawing header and their XML-data exchange* [Technical Specification]
- *Part 305: Creation and exchange of 3D models — Modular tooling systems with adjustable cartridges for boring* [Technical Specification]
- *Part 310: Creation and exchange of 3D models — Turning tools with carbide tips* [Technical Specification]

Introduction

This part of ISO/TS 13399 defines the concept, the terms and the definitions on how to design simplified 3D models of end mills for indexable inserts that can be used for NC-programming, simulation of the manufacturing processes and the determination of collision within machining processes. It is not intended to standardize the design of the cutting tool itself.

A cutting tool is used in a machine to remove material from a workpiece by a shearing action at the cutting edges of the tool. Cutting tool data that can be described by ISO/TS 13399 (all parts) include, but are not limited to, everything between the workpiece and the machine tool. Information about inserts, solid tools, assembled tools, adaptors, components and their relationships can be represented by ISO/TS 13399 (all parts). The increasing demand providing the end-user with 3D models for the purposes defined above is the basis for the development of this series of International Standards.

The objective of ISO/TS 13399 (all parts) is to provide the means to represent the information that describes cutting tools in a computer sensible form that is independent from any particular computer system. The representation will facilitate the processing and exchange of cutting tool data within and between different software systems and computer platforms and support the application of this data in manufacturing planning, cutting operations and the supply of tools. The nature of this description makes it suitable not only for neutral file exchange, but also as a basis for implementing and sharing product databases and for archiving. The methods that are used for these representations are those developed by ISO/TC 184/SC 4 for the representation of product data by using standardized information models and reference dictionaries.

Definitions and identifications of dictionary entries are defined by means of standard data that consist of instances of the EXPRESS entity data types defined in the common dictionary schema, resulting from a joint effort between ISO/TC 184/SC 4 and IEC/TC 3/SC 3D, and in its extensions defined in ISO 13584-24 and ISO 13584-25.

Cutting tool data representation and exchange —

Part 307:

Creation and exchange of 3D models — End mills for indexable inserts

1 Scope

This part of ISO/TS 13399 specifies a concept for the design of tool items, limited to any kind end mills for indexable inserts, together with the usage of the related properties and domains of values.

This part of ISO/TS 13399 specifies a common way of design simplified models that contain the following:

- definitions and identifications of the design features of end mills for indexable inserts, with an association to the used properties;
- definitions and identifications of the internal structure of the 3D model that represents the features and the properties of end mills for indexable inserts.

The following are outside the scope of this part of ISO/TS 13399:

- applications where these standard data may be stored or referenced;
- concept of 3D models for cutting tools;
- concept of 3D models for cutting items;
- concept of 3D models for other tool items not being described in the scope of this International Standard;
- concept of 3D models for adaptive items;
- concept of 3D models for assembly items and auxiliary items.

2 Normative references

The following referenced documents, in whole or in part, are indispensable for the application of this document. For dated references, only the edition cited applies. For undated references, the latest edition of the referenced document (including any amendments) applies.

ISO 5610 (all parts), *Tool holders with rectangular shank for indexable inserts*

ISO/TS 13399-3, *Cutting tool data representation and exchange — Part 3: Reference dictionary for tool items*

ISO/TS 13399-4, *Cutting tool data representation and exchange — Part 4: Reference dictionary for adaptive items*

ISO/TS 13399-50, *Cutting tool data representation and exchange — Part 50: Reference dictionary for reference systems and common concepts*

ISO/TS 13399-60, *Cutting tool data representation and exchange — Part 60: Reference dictionary for connection systems*

ISO/TS 13399-80, *Cutting tool data representation and exchange — Part 80: Creation and exchange of 3D models — Overview and principles*

ISO/TS 13399-201, *Cutting tool data representation and exchange — Part 201: Creation and exchange of 3D models — Regular inserts*

3 Starting elements, coordinate systems, planes

3.1 General

The modelling of the 3D models shall be done by means of nominal dimensions.

WARNING — There is no guarantee that the 3D model, created according to the methods described in this part of ISO/TS 13399, is a true representation of the physical tool supplied by the tool manufacturer. If the models are used for simulation purposes, e.g. CAM simulation, it shall be taken into consideration that the real product dimensions can differ from those nominal dimensions.

NOTE Some definitions are taken from ISO/TS 13399-50.

3.2 Reference system

The reference system consists of the following standard elements as shown in [Figure 1](#):

- **standard coordinate system** — right-handed, rectangular Cartesian system in three-dimensional space, called “primary coordinate system” (PCS);
- **three orthogonal planes** — planes in the coordinate system that contain the axis of the system, named “xy-plane” (XYP), “xz-plane” (XZP) and “yz-plane” (YZP);
- **three orthogonal axes** — axes built as intersections of the three orthogonal plane lines, respectively, named “x-axis” (XA), “y-axis” (YA) and “z-axis” (ZA).

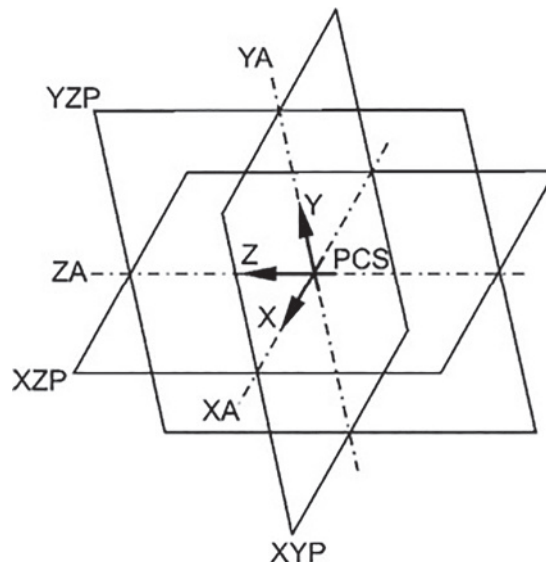

Figure 1 — Reference system

For virtually mounting end mills on to an adaptive item, an additional reference system shall be defined. This reference system shall be called “mounting coordinate system” (MCS). It is located at the starting point of the protruding length of a tool item. The orientation is shown in [Figure 2](#).

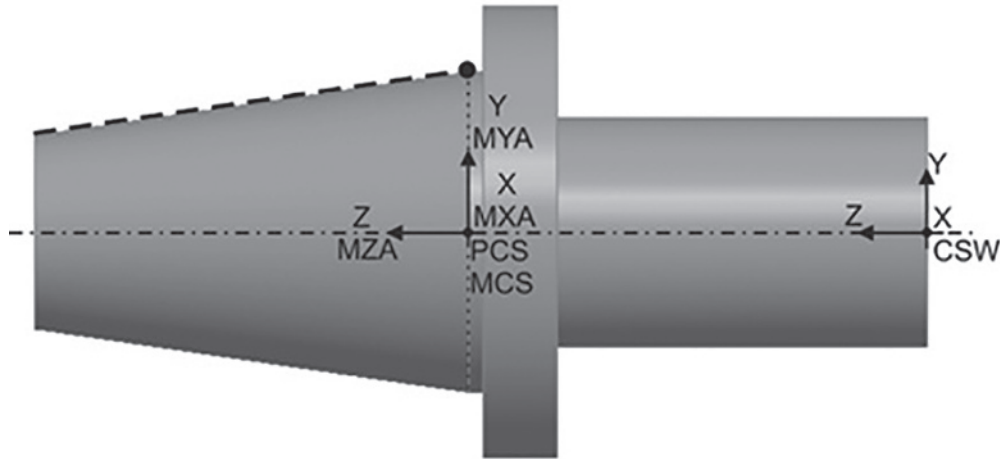

Figure 2 — Orientation of “PCS” and “MCS” reference system (example)

3.3 Coordinate system at the cutting part

The coordinate system at the cutting part, named “coordinate system in process” (CIP), with a defined distance to the PCS shall be oriented as follows:

- the origin is on a plane that is parallel to the xy-plane of PCS and is located on the most front cutting point;
- z-axis of CIP points to the PCS;
- z-axis of CIP is collinear to the z-axis of PCS;
- y-axis of CIP is parallel to the y-axis of PCS.

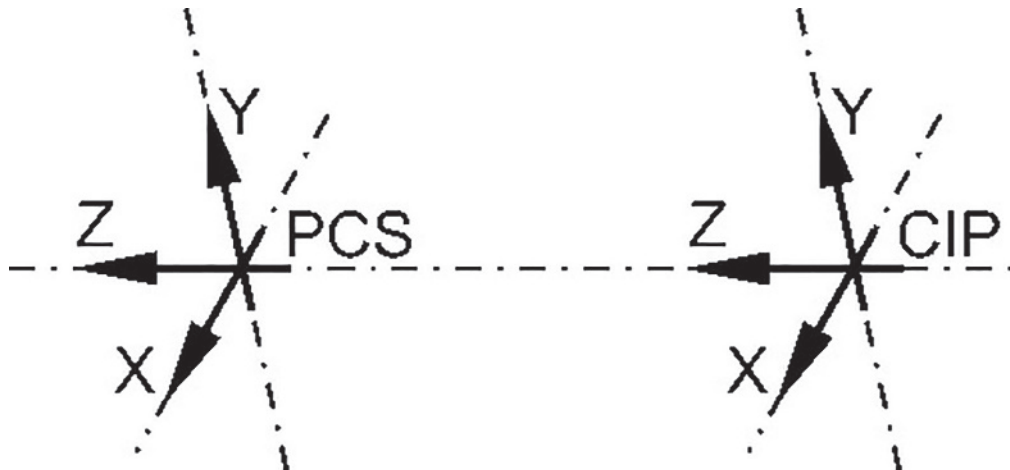

Figure 3 — Orientation of CIP

If the 3D modelling software gives the possibility to include interfaces for components to, for example, mount a front-cutting disk onto a complete cutting tool, it shall be advised to use the coordinate system “CIP”.

If necessary, another designation should be given to the interface of the component (dependent on the software). The name is “CSIF” (“coordinate system interface”) and includes the coordinate system “CIP”.

3.4 Planes

The modelling takes place based on planes according to [Figure 4](#) and shall be used as reference, if applicable. Therefore, it shall be ensured that the model is able to vary or single features of independent design features shall be suppressed by means of changing the value of one or more parameter of the model design. Furthermore, the identification of the different areas shall be simplified in using the plane concept, even if they contact each other with the same size, e.g. chip flute, shank, and so on.

For the 3D visualization of end mills for indexable inserts, the general planes shall be determined as follows and as in [Figure 4](#):

- “TEP” — the tool end plane is located at that end of the connection that points away from the workpiece; if the tool does not have a contact surface and/or a gauge line, the TEP is coplanar with the xy-plane of the PCS; the overall length (OAL) is the distance between CIP and TEP;
- “CLP” — (cutting length plane) plane for the cutting depth maximum (APMX), based on “CIP”;
- “HEP” — (head end plane) plane that determines the most front of the end mill, based on “CIP” and is coplanar to the xy-plane of CIP;
- “LHP” — plane for the head length (LH), based on “CIP”;
- “LPRP” — plane for the protruding length (LPR), based on “MCS”;
- “LSP” — plane for the shank length (LS), based on “PCS”;
- “LUP” — plane for the maximum usable length (LUX), based on “CIP”.

Other planes, if necessary, are defined in the appropriate Clauses.

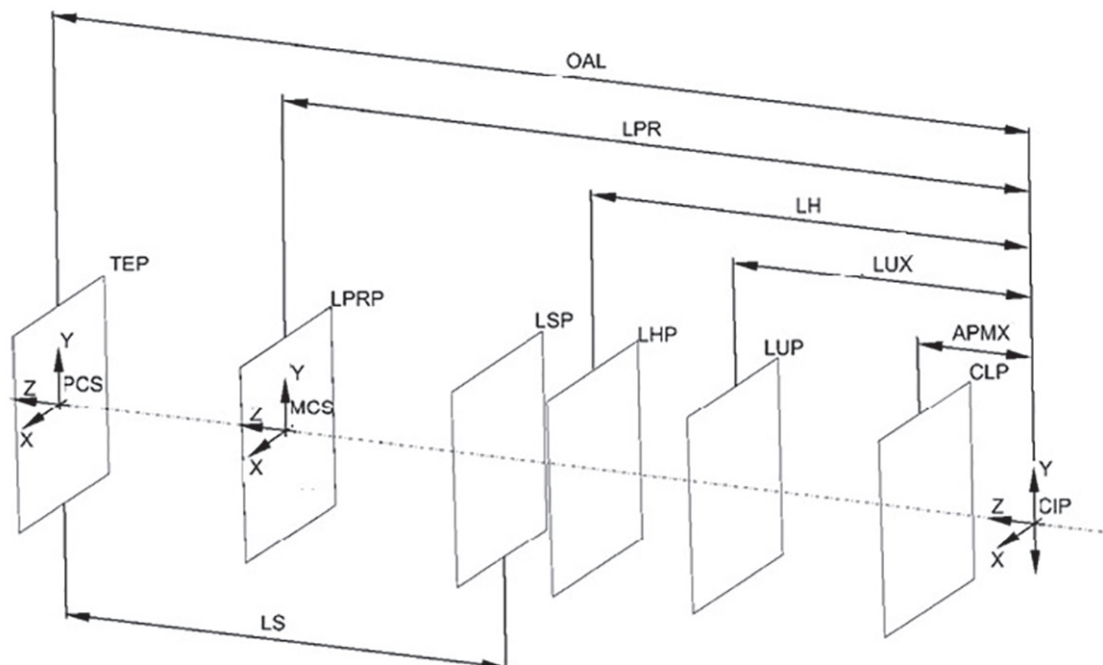

Figure 4 — Planes for design

3.5 Design of the pocket seat and cutting reference point (CRP) of the insert

NOTE If regular inserts have a specific design and are not interchangeable between vendors, the location of the MCS is at the manufacturer's discretion, either on the top face or on the bottom face. The orientation of the axis has to follow the definitions in this part of ISO/TS 13399.

The final position of the pocket seat shall be designed by means of designing an insert. This feature shall be used for subtraction from the tool body. To give the possibility to use inserts with different corner radii, only that corner defining the functional dimensions shall carry the corner radius. The remaining corners shall be designed without a corner radius.

The size of the corner radius shall meet the determination of a master radius. [Table 1](#) shows the size of the corner radii, dependent from the inscribed circle as given in ISO 5610.

Table 1 — Dependency of inscribed circle and corner radius

Dimensions in millimetres

Inscribed circle	Corner radius
3,970	0,4
4,760	0,4
5,560	0,4
6,350	0,4
9,525	0,8
12,700	0,8
15,875	1,2
19,050	1,2
22,250	2,4
25,400	2,4
31,750	2,4

NOTE At rectangular (style L) and parallelogram-shaped (styles A, B, K) inserts, the longer side that is equal to the inscribed circle determines the size of the corner radius.

MCS-coordinate system of the insert (MCS_INSERT) and the PCS-coordinate system of the insert (PCS_INSERT) are oriented differently to the primary coordinate system of the tool (PCS_TOOL). The orientation is shown in [Figures 5](#) and [7](#).

The neutral position of an insert is determined as follows.

- a) The origin of the MCS_INSERT shall be positioned onto the centre of the inscribed circle; at rectangular and parallelogram-shaped inserts the point of origin shall be determined through the intersection of the two diagonal lines.
- b) The x-axis of MCS_INSERT shall be parallel to the x-axis of PCS_INSERT.
- c) The y-axis of MCS_INSERT shall be parallel to the y-axis of PCS_INSERT.
- d) The z-axis of MCS_INSERT shall be parallel to the z-axis of PCS_INSERT.
- e) The x-axis of PCS_INSERT shall be collinear to the x-axis of PCS_TOOL.
- f) The y-axis of PCS_INSERT shall be collinear to the z-axis of PCS_TOOL.
- g) The Z-axis of PCS_INSERT shall be collinear to the y-axis of PCS_TOOL.

Positioning of the insert into the functional location shall be done as follows.

- a) Design with end-cutting edge angle on a right-handed tool, commonly used on the face of the end mill, typically for spot-facing cutters.
 - 1) Only inserts located in the second quadrant of the primary coordinate system of the insert, also called “left handed” inserts, shall be used.
 - 2) The insert shall be rotated by 90-KAPR degrees in mathematic positive direction (counter-clockwise) about the y-axis of the PCS_TOOL.

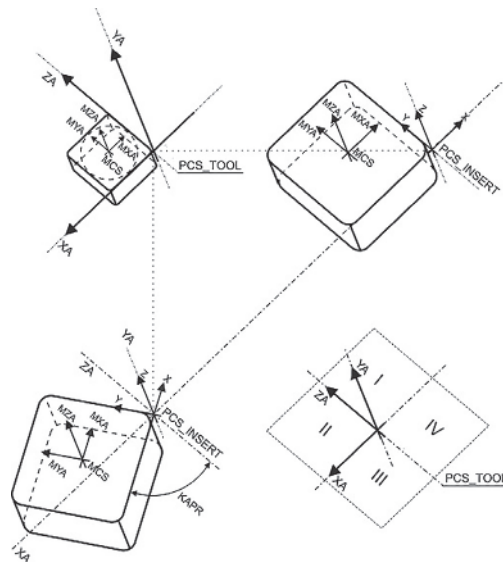

Figure 5 — Orientation of PCS_INSERT, MCS_INSERT and PCS_TOOL on end cutting edge angle

- 3) The cutting reference point (CRP), defined in ISO/TS 13399-50, is the point where the functional dimensions are based.
- 4) The coordinate system of CRP (CS_CRP) is defined as follows:
 - i) the x-axis of CS_CRP is collinear to the x-axis of PCS_INSERT;
 - ii) the y-axis of CS_CRP is parallel to the y-axis of PCS_INSERT;
 - iii) the z-axis of CS_CRP is parallel to the z-axis of PCS_INSERT.
- 5) If the tool is defined with an axial rake and a radial rake angle that are unequal 0 degree, the insert have to be rotated about its CRP. The orientation is shown in [Figure 6](#). Therefore, two axes shall be added:
 - i) GAMP-axis positioned on CRP with its vector that is parallel to x-axis of PCS_TOOL — defines the rotation of axial rake angle;
 - ii) GAMF-axis positioned on CRP with its vector that is parallel to z-axis of PCS_TOOL — defines the rotation of radial rake angle.

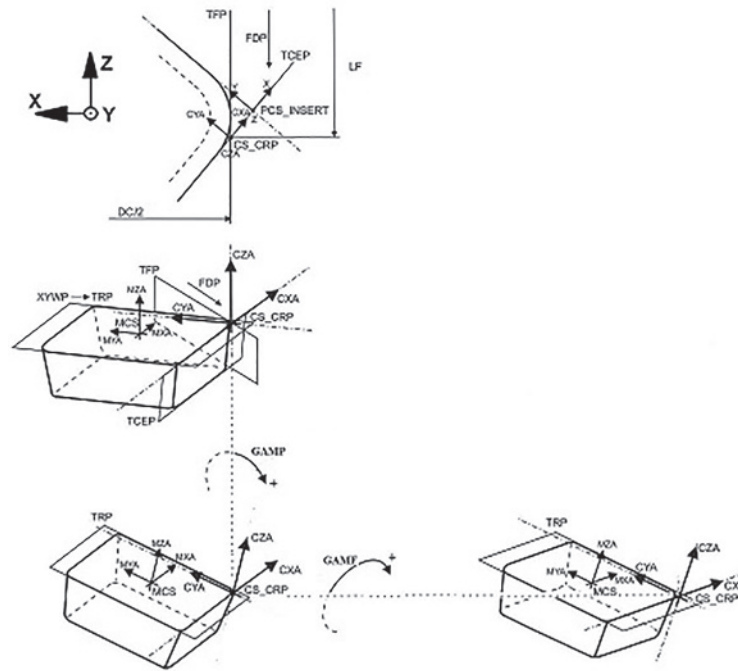

Figure 6 — Axial and radial rake angle on insert

- b) Design with side-cutting edge angle on a right-handed tool, commonly used on the periphery of the end mill, typically for all kinds of side-cutting end mills.
- 1) Only inserts located in the first quadrant of the primary coordinate system of the insert, also called “right handed” or “neutral” inserts, shall be used.
 - 2) The insert shall be rotated by KAPR degrees in mathematic positive direction (counter-clockwise) about the y-axis of PCS_TOOL.

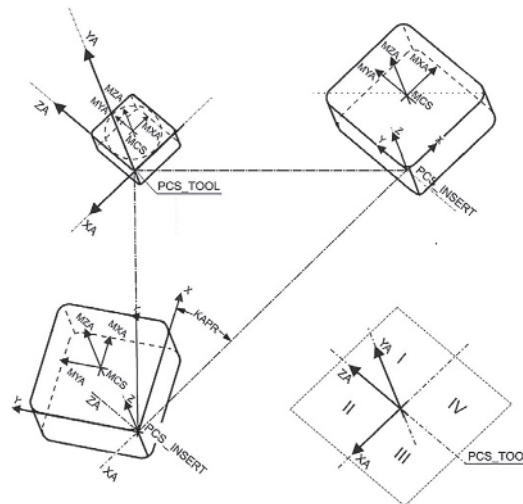

Figure 7 — Orientation of PCS_INSERT, MCS_INSERT and PCS_TOOL on side-cutting edge angle

- 3) The cutting reference point (CRP), defined in ISO/TS 13399-50, is the point where the functional dimensions are based.

The position of the C_CRP is defined with the properties DC/2 and LF.

3.6 Adjustment coordinate system on workpiece side

3.6.1 General

For mounting components, the coordinate systems “CSW_{x_y}” (coordinate system workpiece side) shall be defined according to ISO/TS 13399-50.

3.6.2 Designation of the coordinate system workpiece side

Case 1 One coordinate system at the workpiece side shall be designated as “CSW”.

Case 2 One coordinate system at workpiece side on different levels shall be designated as “CSW_x”, e.g. “CSW1”, “CSW2”. The numbering starts at the workpiece side and ends at the machine side in the direction of the positive z-axis.

Case 3 Multiple coordinate systems at one level, but different angles and not at the centre of the tool axis shall be designated with “CSW_{x_y}”, where the “x” defines the level and the “y” defines the number of the coordinate system itself. The counting starts at the three o’clock position, counting in counter-clockwise direction while looking towards the machine spindle (positive z-axis).

Case 4 Multiple coordinate systems at one level, one angle and different diameters shall be designated as described in Case 3. The counting shall start at the smallest diameter.

Case 5 Multiple coordinate systems at one level, different angles and different diameters shall be designated as described in Case 3. The counting shall start at the smallest diameter and at the three o’clock position, counting in counter-clockwise direction while looking towards the machine spindle (positive z-axis).

Figure 8 shows an example of the arrangement of the CSWs.

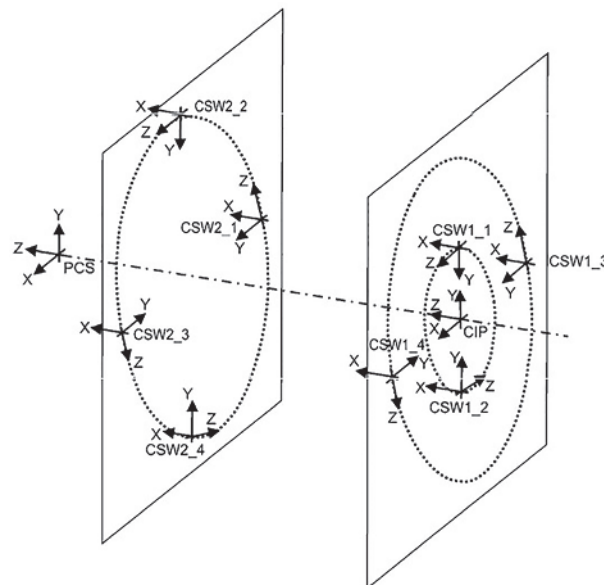

Figure 8 — Adjustment coordinate system on workpiece side

The MCS_INSERT shall be placed onto the CSW_{x_y} of the tool with determinations as follows:

- the x-axis of CSW_{x_y} is parallel to the x-axis of CRP;
- the y-axis of CSW_{x_y} is parallel to the y-axis of CRP;
- the z-axis of CSW_{x_y} is parallel to the z-axis of CRP.

Figure 9 shows an example of the mounting of insert onto the pocket seat.

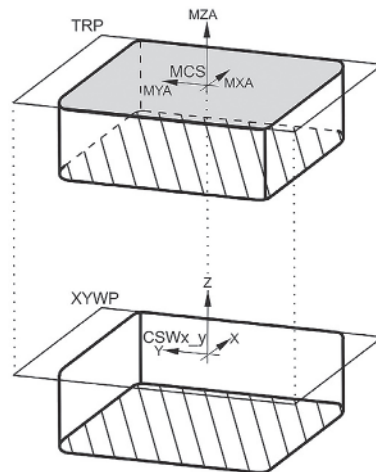

Figure 9 — Mounting of insert onto pocket seat

4 Design of the model

4.1 General

The sketches (outline contours) and features of the crude model may not contain details like slots, chamfers, roundings and grooves. These features shall be designed as separate design elements after the crude geometry and shall be grouped as detail geometry. Based on the non-cutting features (group “NOCUT”), the cutting features shall be loaded as assembly parts (group “CUT”) into the basic model. For the group “DETAILS”, see [Clause 14](#).

The sequence of the model structure shall be kept as described and there shall be no reference between the connection and the basic body. Only the group “DETAILS” may contain references to other design features.

End mills for indexable inserts shall be designed as rotational features:

- basic geometry containing connection and tool body designed as rotating body;
- geometry of the tool body (chip flute, pocket seat, etc.);
- geometry of the connection;
- details (chamfers, roundings, slots, etc.).

The basic shapes of end mills are designed with cylindrical shank exemplarily and positioned onto the PCS.

All examples are designed with 0 degree axial and radial rake angle.

The total amount of design elements is dependent on the level of detail and on the complexity of the cutting tool.

The specific model structures of the different shapes of end mills for indexable inserts are described in the next Clauses of this part of ISO/TS 13399.

4.2 Necessary parameters for the connection interface feature

Information about the connection interface code shall be filled as properties within the model and named as parameters as listed in [Table 2](#):

Table 2 — Parameter list for connection interface feature

Preferred symbol	Description	Source of symbol	ISO-ID number
CCMS	connection code machine side	ISO/TS 13399-3 and ISO/TS 13399-4	71D102AE3B252
CCTMS	connection code type machine side	ISO/TS 13399-60 short name of subtype of connection_interface_feature	feature_class
CCFMS	connection code form machine side	ISO/TS 13399-60 number of the variant of the subtype of connection_interface_feature	feature_class
CZCMS	connection size code machine side	connection size code (dependent of side)	71FC193318002

The information above and other relevant properties shall be incorporated into the model as parameters or shall be taken as a separate file.

4.3 Necessary properties for inserts

4.3.1 General

Necessary properties for the design of the pocket seat features shall be taken in accordance with the defined properties for cutting items (see ISO/TS 13399-2). To be able to differentiate between tool-item and cutting-item properties, a postfix shall be added to the preferred symbols of the cutting-item properties. The postfix has the same code and sequence as the different coordinate systems on workpiece side that are defined in [3.6](#).

4.3.2 Properties for equilateral, equiangular and equilateral, non-equiangular inserts

Equilateral and equiangular inserts are the following:

- H — hexagonal insert;
- O — octogonal insert;
- P — pentagonal insert;
- S — square insert;
- T — triangular insert.

Equilateral and non-equiangular inserts are the following:

- C, D, E, M, V — rhombic insert;
- W — trigon insert.

[Table 3](#) lists the properties for regular inserts with inscribed circle.

Table 3 — Properties for modelling equilateral, equiangular and equilateral, non-equiangular pocket seats

Preferred name	Preferred symbol
clearance angle major	AN
insert included angle	EPSR
insert included angle minor	EPSRN
inscribed circle diameter	IC
cutting edge length ^a	L ^a
corner radius	RE
corner radius minor	REN
insert thickness	S
^a L is calculated and is dependent on IC and EPSR.	

4.3.3 Properties for non-equilateral, equiangular and non-equilateral, non-equiangular inserts

Non-equilateral and equiangular inserts:

- L — rectangular insert

Non-equilateral and non-equiangular inserts:

- A, B, K — parallelogram-shaped insert

[Table 4](#) lists the properties for regular inserts of rectangular and parallelogram shape.

Table 4 — Properties for modelling non-equilateral, equiangular and non-equilateral, non-equiangular pocket seats

Preferred name	Preferred symbol
clearance angle major	AN
clearance angle minor	ANN
insert included angle	EPSR
insert length	INSL
corner radius	RE
corner radius minor	REN
insert thickness	S
insert width	W1
cutting edge length ^a	L ^a
^a L is calculated and is dependent on INSL and EPSR.	

4.3.4 Design of the pocket seat feature

The design shall be done in accordance with ISO/TS 13399-201, but without any corner configuration on the opposite side where the functional dimensions are based.

5 End mill, non-centre cutting, single row

5.1 General

[Figure 10](#) shows the properties to be used for the design of a single row, non-centre cutting end mill.

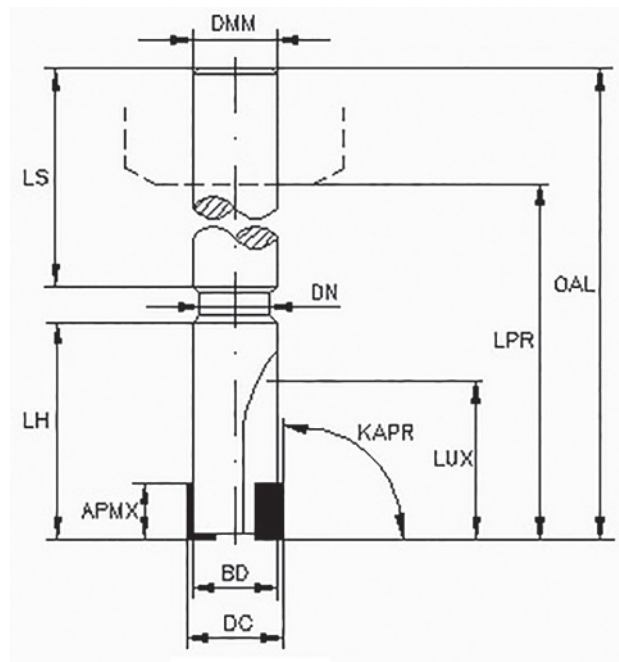

Figure 10 — Determination of properties of single row, non-centre cutting end mills

5.2 Necessary properties

Table 5 lists the properties needed for the modelling of single row, non-centre cutting end mills.

Table 5 — Properties for the modelling of a single row, non-centre cutting end mill

Preferred name	Preferred symbol
depth of cut maximum	APMX
plunge depth maximum	AZ
body diameter	BD
cutting diameter	DC
shank diameter	DMM
neck diameter	DN
rake angle radial	GAMF
rake angle axial	GAMP
tool cutting edge angle	KAPR
head length	LH
protruding length	LPR
usable length maximum	LUX
shank length	LS
overall length	OAL
chip flute offset distance	OFFCFEX
ramping angle maximum	RMPX
face effective cutting edge count	ZEFF
face mounted insert count	ZNF

5.3 Basic geometry

The basic of that part is a rotational design feature, which contains all elements between the plane “TEP” und the separation plane “CIP” to the cutting part.

The sketch (outline contour) includes all the real measure elements above and shall be designed on the xz-plane of the “PCS”. The rotational axis is the standard z-axis.

The design of the sketch shall be as follows.

- The sketch shall be determined as a half section.
- The sketch shall be constrained to the coordinate system “PCS” and to the planes “TEP” and “CIP” according to [Figure 8](#). If the CAD software does not support the use of datum planes, the sketch shall be fully dimensioned. Otherwise the distances shall be in conjunction with the defined datum planes.
- The dimensioning shall be done with the appropriate properties listed in [Table 2](#).

The sketch shall be revolved about the z-axis by 360°.

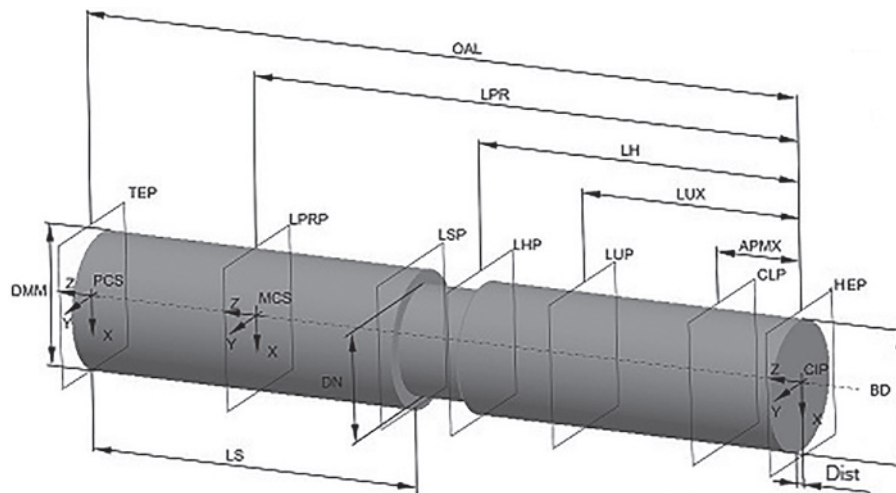

Figure 11 — Basic geometry of an end mill

NOTE The distance between the CIP and the most front of the body may also be defined as property “AZ”, if applicable.

The parameter “Dist” is a function of the insert properties “insert thickness” (S), “clearance angle major” (AN) and an offset, which is in the range of 0,2 mm to 0,5 mm. It is calculated using Formula (1):

$$\text{Dist} = S \times \tan(\text{AN}) + \text{offset} \quad (1)$$

5.4 Determination of the position of the mounting coordinate system of insert

A coordinate system workpiece side and the corresponding planes shall be determined for each insert in accordance with their definitions given in ISO/TS 13399-50.

The coordinate systems, “CSW_{x_y}”, shall be referenced to “PCS”. The position is determined through:

- the dimensions DC, LF;
- the geometry of the insert;
- the cutting reference point.

For the determination of the CSWs, [Figure 12](#) illustrates the location of the CSWs of single row, non-centre cutting end mills.

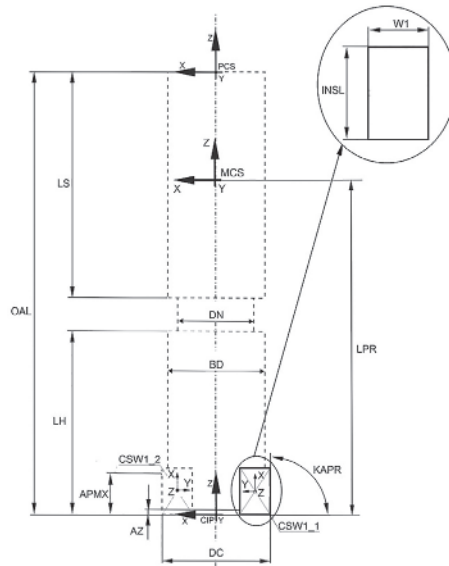

Figure 12 — Determination of CSW_{x_y} of single row, non-centre cutting end mills

For the determination of the CSWs, [Figure 13](#) illustrates the location of the CSWs in relation to PCS.

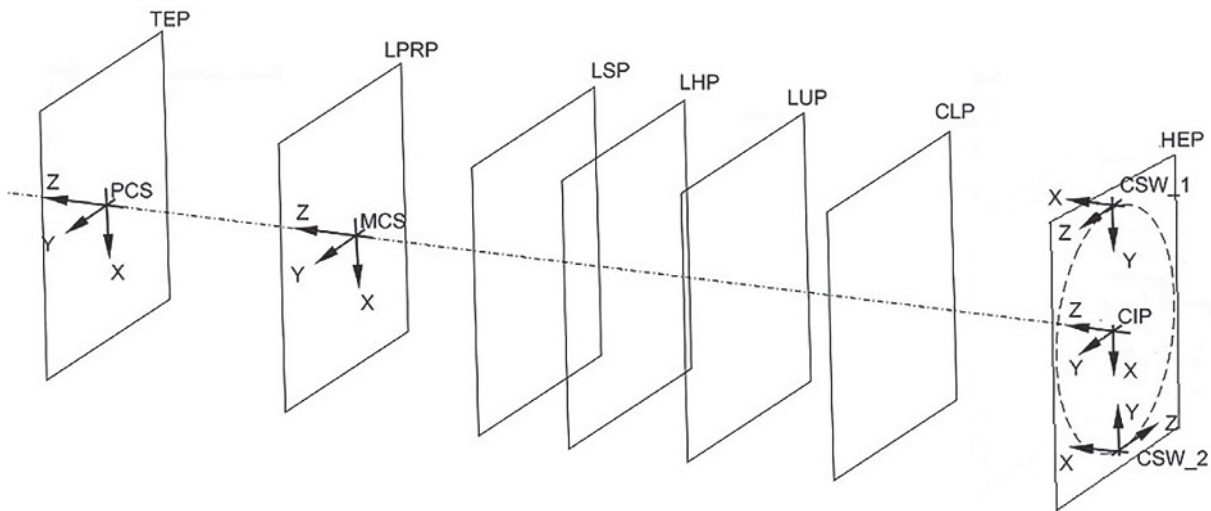

Figure 13 — Location of CSWs

5.5 Chip flute and pocket seat

The chip flute shall be designed as solid body for subtraction from the tool body. The sketch of the chip flute shall be referenced to the xz-plane of PCS and to CIP. The chip flute body shall be positioned to its final position in using the properties “GAMF”, “GAMP”, “KAPR” and the point “CRP” or the property “OFFCFEX”.

The number and location of the chip flutes shall be ordered using the CAD-arrangement function and with the parameter “OFFCFEX”, as shown in [Figure 14](#).

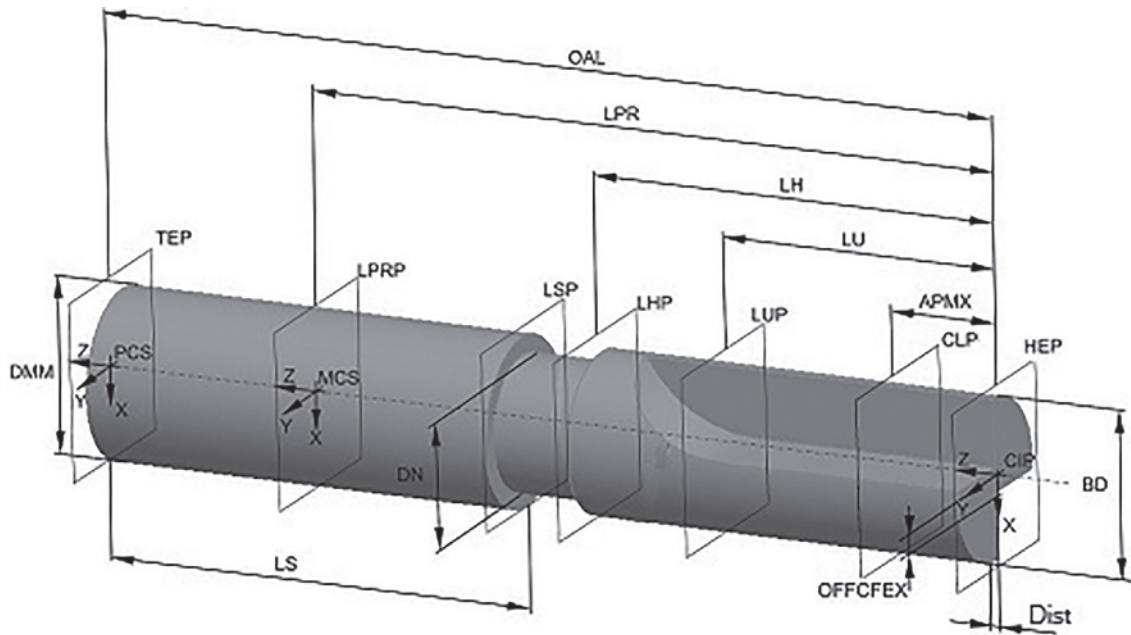

Figure 14 — Chip flute

To position the pocket seat on to the body, the corresponding CSW_{x_y} shall be selected. The pocket seat shall be designed with reference to the xy-plane of the PCS_INSERT and transformed to the corresponding CSW. [Figures 15](#) and [16](#) show the positions of the corresponding CSWs and CRPs.

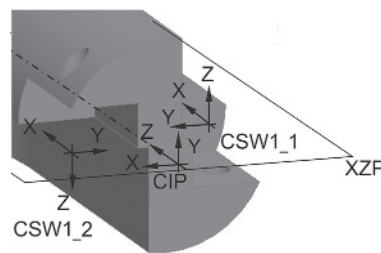

Figure 15 — Position of CSWs

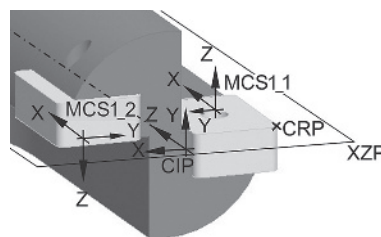

Figure 16 — Position of CRP

5.6 Assembly of a single row, non-centre cutting end mill

The assembly of the end mill shall be done using the CSWs. The mounting coordinate system of the inserts, MCS_INSERT, shall be mated directly onto the corresponding coordinate system workpiece side, CSW_{x_y}, as illustrated in [Figure 17](#).

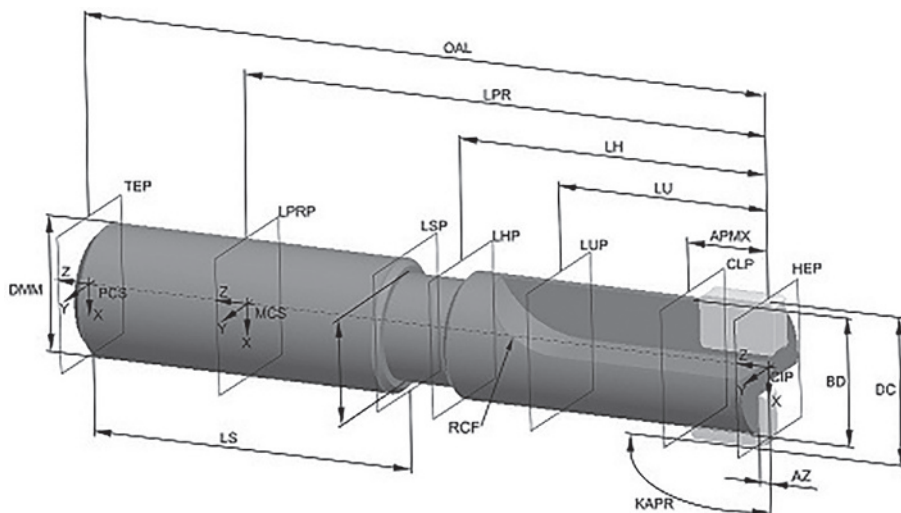

Figure 17 — Assembly of a single row, non-centre cutting end mill

6 Single row, non-centre cutting V-groove end mill

6.1 General

Figure 18 shows the properties to be used for the design of a single row, non-centre cutting V-groove end mill.

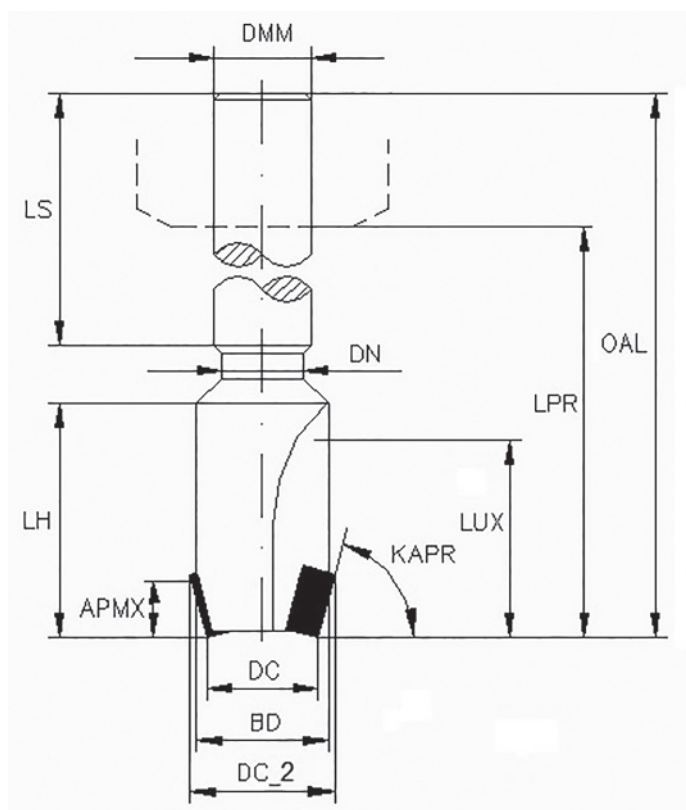

Figure 18 — Determination of properties of a V-groove end mill

6.2 Necessary properties

[Table 6](#) lists the properties needed for the modelling of single V-groove end mills.

Table 6 — Properties for the modelling of a V-groove end mill

Preferred name	Preferred symbol
depth of cut maximum	APMX
plunge depth maximum	AZ
body diameter	BD
cutting diameter	DC
cutting diameter 2	DC_2
shank diameter	DMM
neck diameter	DN
rake angle radial	GAMF
rake angle axial	GAMO
tool cutting edge angle	KAPR
head length	LH
protruding length	LPR
shank length	LS
usable length maximum	LUX
overall length	OAL
ramping angle maximum	RMPX
face effective cutting edge count	ZEFF
face mounted insert count	ZNF

6.3 Basic geometry

The structure of the model is described in [5.3](#) and is in accordance with [Figures 11](#) and [19](#).

6.4 Determination of the position of the mounting coordinate system of insert

[Figures 19](#) and [20](#) show the orientation and location of the CSWs.

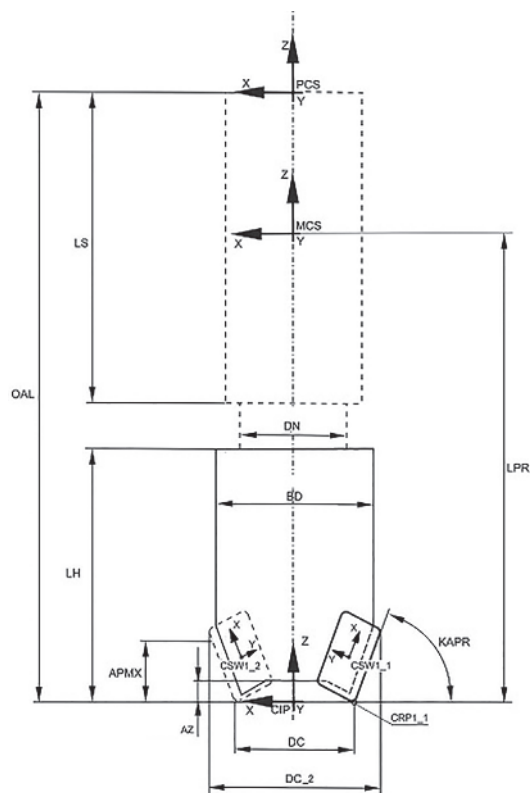

Figure 19 — Determination of CSW_{x_y} of a V-groove end mill

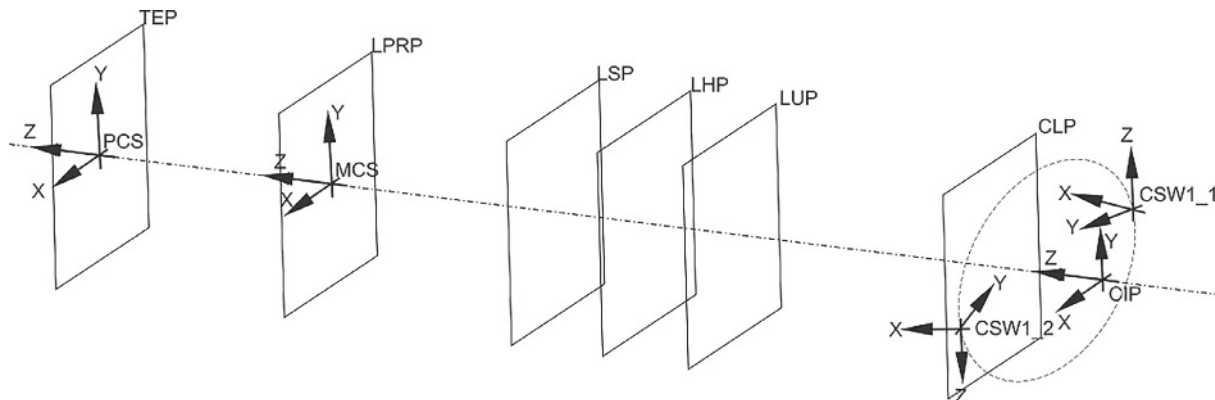

Figure 20 — Location of CSWs of a V-groove end mill

6.5 Chip flute and pocket seat

See 5.5 for the modelling of the chip flute and the pocket seat. The chip flute shall be designed according to the used insert shape and the maximum usable length. To give as much bending stiffness as possible, the chip flute shall also follow the insert contours as shown in Figures 21 and 22.

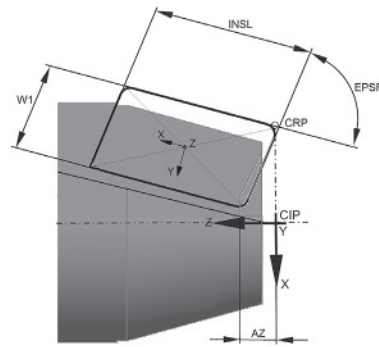

Figure 21 — Chip flute and pocket seat sketch

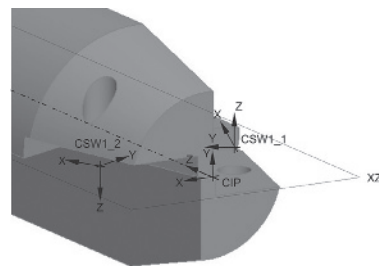

Figure 22 — Position of CSWs

To position the pocket seat onto the body, the corresponding CSW_{x_y} shall be selected. The pocket seat shall be designed with reference to the xy-plane of the PCS_INSERT and transformed to the corresponding CSW.

See [Figure 23](#) for the position of the CRPs.

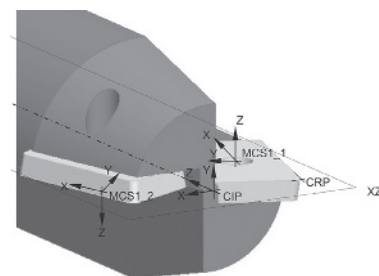

Figure 23 — Position of CRPs

6.6 Single row, non-centre cutting V-groove end mill assembly

The assembly of the end mill shall be done using the CSWs. The mounting coordinate system of the inserts, MCS_INSERT, shall be mated directly on to the corresponding coordinate system workpiece side, CSW_{x_y}. See [Figure 24](#).

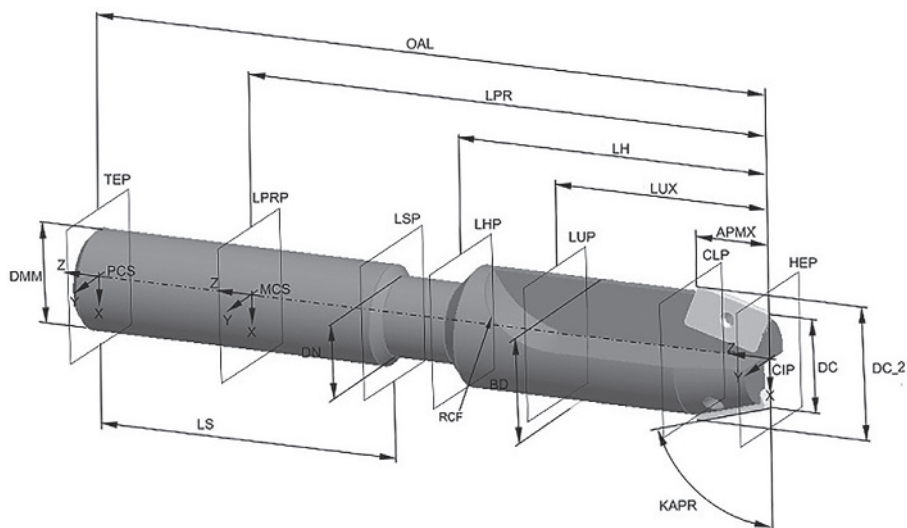

Figure 24 — Assembly of V-groove end mills

7 Single row, non-centre-cutting dovetail end mill

7.1 General

Figure 25 shows the properties to be used for the design of a single row, non-centre-cutting dovetail end mill.

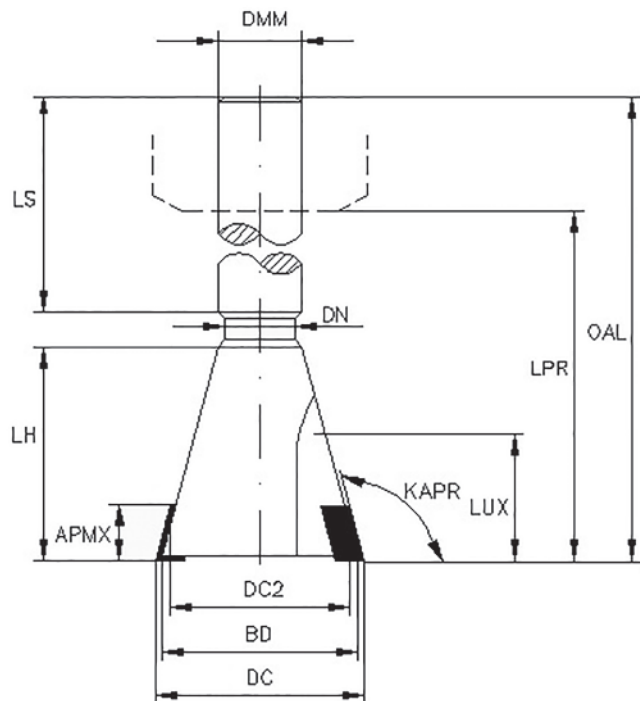

Figure 25 — Determination of properties of a dovetail end mill

7.2 Necessary properties

See 7.2 and Table 6 for necessary properties.

7.3 Basic geometry

The structure of the model is described in 5.3 and in [Figure 11](#). It is in accordance with 6.3 and [Figure 19](#).

7.4 Determination of the position of the mounting coordinate system of insert

See [6.4](#), [Figure 19](#) and [Figure 20](#) for the determination of CSWs and the locations in reference to the PCS. Use $KAPR > 90^\circ$.

7.5 Chip flute and pocket seat

See [6.5](#) for the design of the chip flute and [Figure 26](#) for the pocket seat.

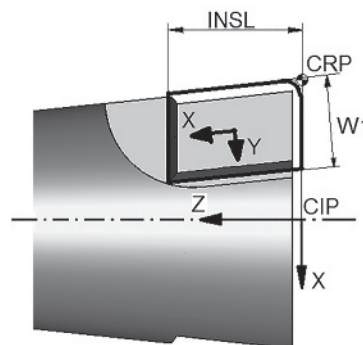

Figure 26 — Chip flute and pocket seat sketch

To position the pocket seat onto the body, the corresponding CSW_{x_y} shall be selected. The pocket seat shall be designed with reference to the xy -plane of the PCS_INSERT and transformed to the corresponding CSW, as shown in [Figures 27](#) and [28](#).

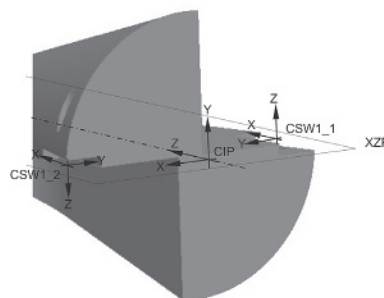

Figure 27 — Position of CSWs

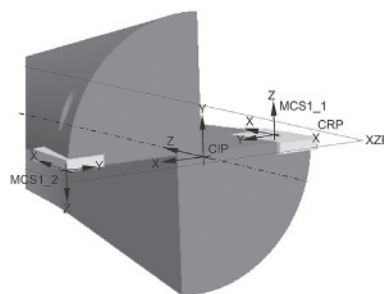

Figure 28 — Position of CRPs

7.6 Single row, non-centre-cutting dovetail end mill assembly

The assembly of the end mill shall be done using the CSWs as shown in [Figure 29](#). The mounting coordinate system of the inserts, MCS_INSERT, shall be mated directly onto the corresponding coordinate system workpiece side, CSWx_y.

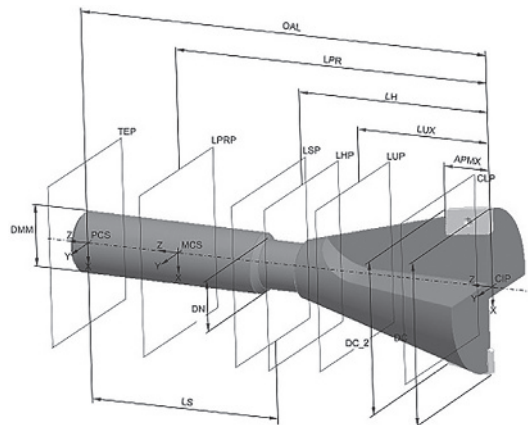

Figure 29 — Assembly of a dovetail end mill

8 T-slot end mill

8.1 General

[Figure 30](#) shows the properties to be used for the design of a T-slot end mill.

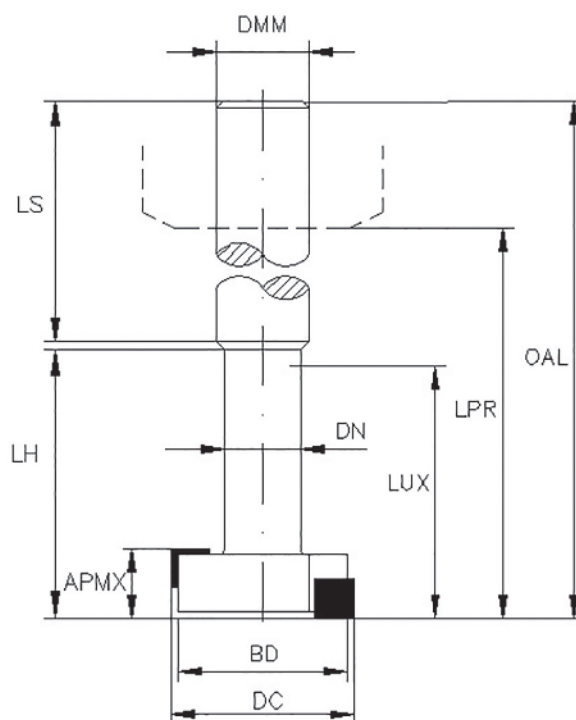

Figure 30 — T-slot end mill: determination of properties

8.2 Necessary properties

[Table 7](#) lists the properties needed for modelling T-slot end mills.

Table 7 — Properties for the modelling of a T-slot end mill

Preferred name	Preferred symbol
depth of cut maximum	APMX
body diameter	BD
cutting diameter	DC
shank diameter	DMM
neck diameter	DN
rake angle radial	GAMF
rake angle axial	GAMO
protruding length	LPR
shank length	LS
usable length maximum	LUX
overall length	OAL
face effective cutting edge count	ZEFF
peripheral effective cutting edge count	ZAFP
face mounted insert count	ZNF
peripheral mounted insert count	ZNP

8.3 Basic geometry

The structure of the model is described in [5.3](#) and is in accordance with [Figures 11](#) and [31](#).

8.4 Determination of the position of the mounting coordinate system of insert

The inserts shall be positioned on two different levels to be able to get the appropriate cutting length as shown in [Figure 31](#).

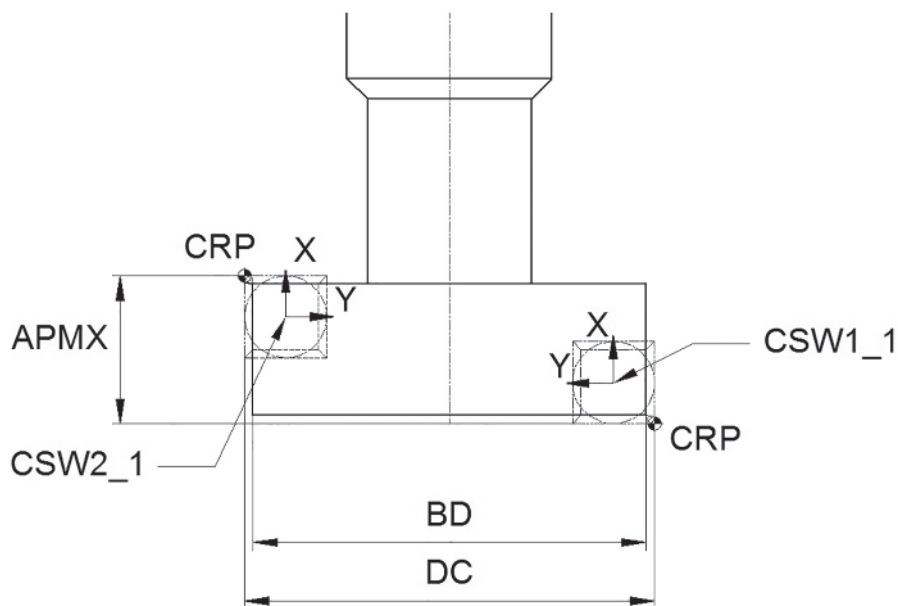

Figure 31 — Determination of CSW_{x_y} for T-slot end mill

See [Figure 32](#) for the nomenclature of the CSWs. The design shall be done here exemplarily with two inserts on the face position (position “A”) and two inserts on the peripheral position (position “B”).

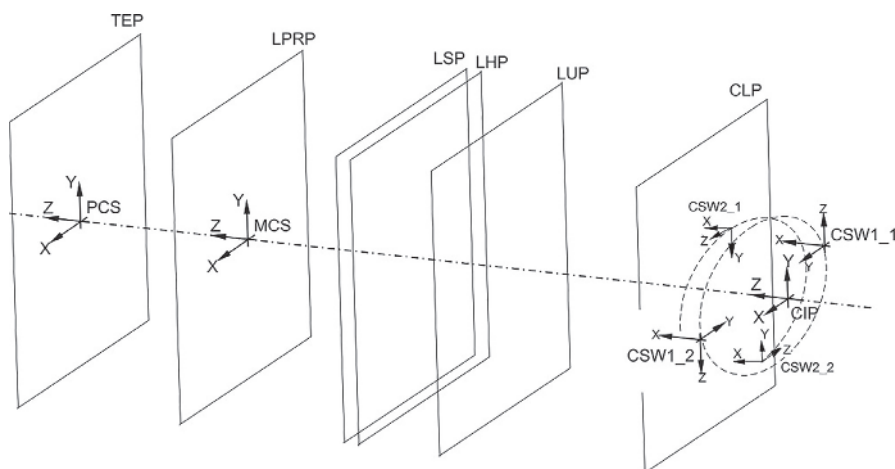

Figure 32 — Location of CSWs of T-slot end mill

8.5 Chip flute and pocket seat

See [5.5](#) for the design of the chip flute and the pocket seat.

It is important for the design that the inserts on the face position “A” shall be right-handed inserts, while the inserts on the peripheral position “B” shall be left-handed inserts. See also [Figures 33](#) and [34](#).

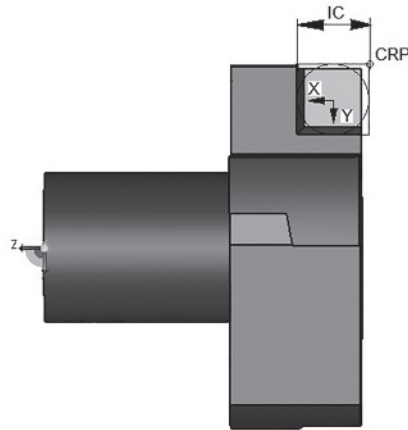

Figure 33 — Position “A” of pocket seats

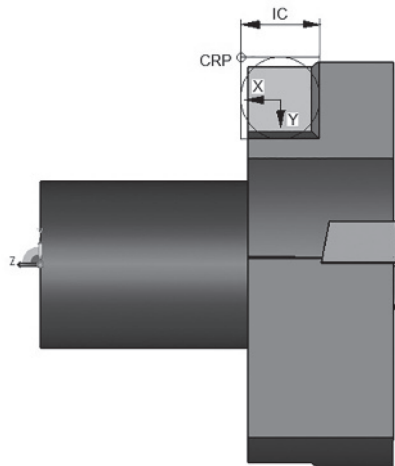

Figure 34 — Position “B” of pocket seats

8.6 Assembly of a T-slot end mill

The assembly of the end mill shall be done using the CSWs. The mounting coordinate system of the inserts, MCS_INSERT, shall be mated directly onto the corresponding coordinate system workpiece side, CSW_{x_y}. See [Figure 35](#) for the assembled T-slot end mill.

9.2 Necessary properties

Table 8 lists the properties being needed for the modelling of rounded end mills.

Table 8 — Properties for the modelling of a rounded end mill

Preferred name	Preferred symbol
depth of cut maximum	APMX
plunge depth maximum	AZ
body diameter	BD
cutting diameter	DC
cutting diameter, maximum	DCX
shank diameter	DMM
neck diameter	DN
rake angle radial	GAMF
rake angle axial	GAMO
head length	LH
protruding length	LPR
shank length	LS
usable length maximum	LUX
overall length	OAL
profile radius	PRFRAD
ramping angle maximum	RMPX
face effective cutting edge count	ZEFF
face mounted insert count	ZNF

9.3 Basic geometry

The structure of the model is described in 5.3 and is in accordance with Figures 11, 37, 38 and 39.

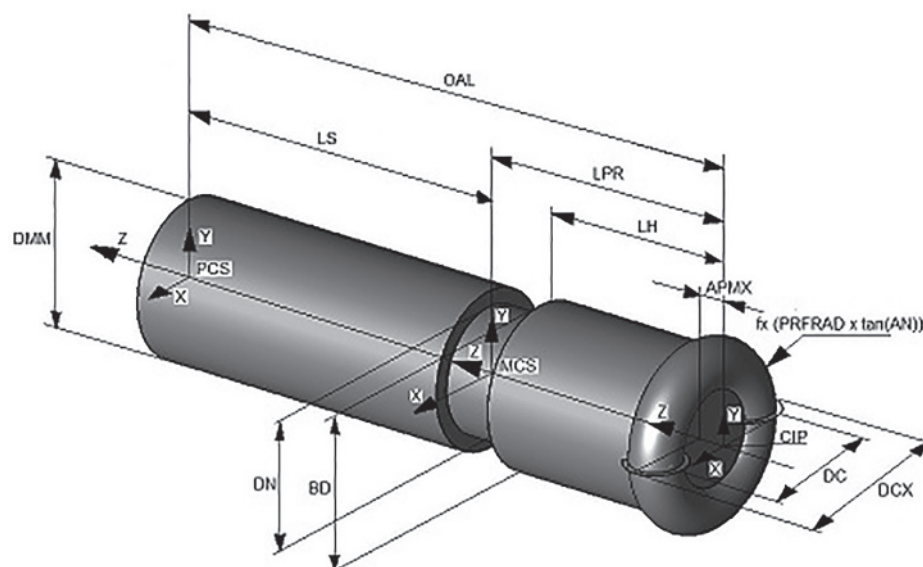

Figure 37 — Basic geometry of rounded end mills

For the basic geometry, the contour beyond the round inserts shall be designed in accordance with the shape of the insert. For the ability to make undercuts, the body diameter, BD, shall be smaller than the radius contour beyond the round insert (see also 9.4 and Figure 38).

9.4 Determination of the position of the mounting coordinate system of insert

Figures 38 and 39 specify the CSWs needed for positioning of the pocket seats.

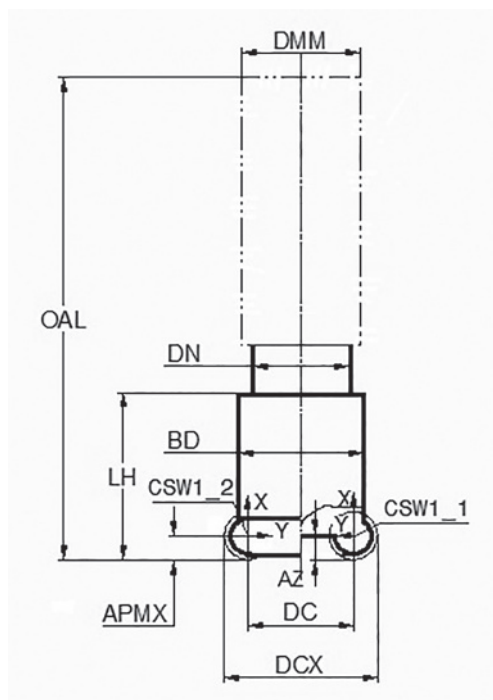

Figure 38 — Determination of CSW_{x_y} of a rounded end mill

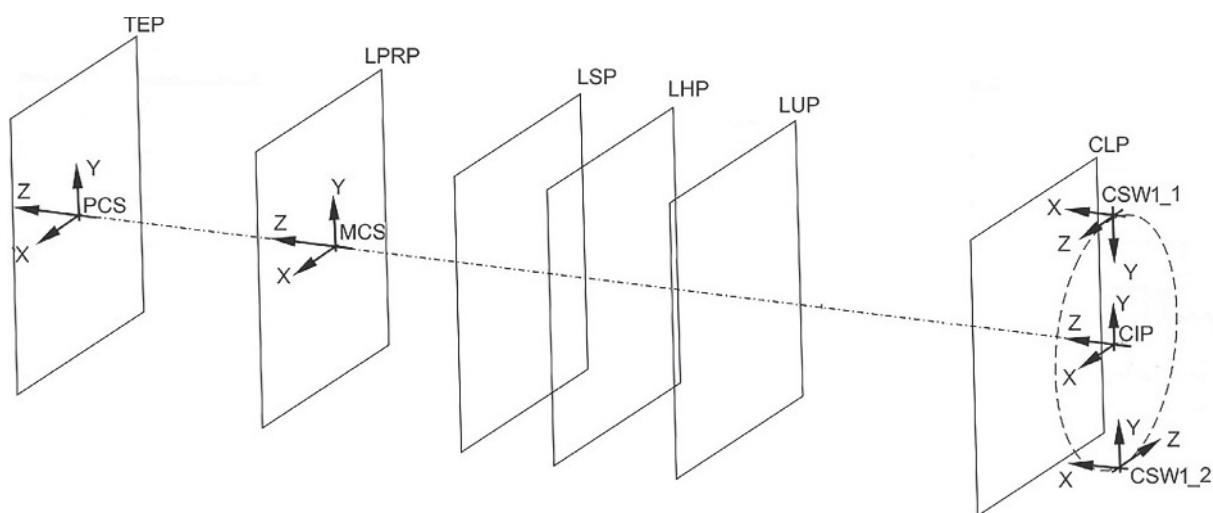

Figure 39 — Location of CSW_{x_y} of a rounded end mill

9.5 Chip flute and pocket seat

See 5.5 for the modelling of the chip flute and the pocket seat. The chip flute shall be designed according to the used insert shape and the maximum usable length. To give as much bending stiffness as possible,

the chip flute shall also follow the insert contours. See [Figures 40, 41, 42](#) and [43](#) for the design and the location of the pocket seat.

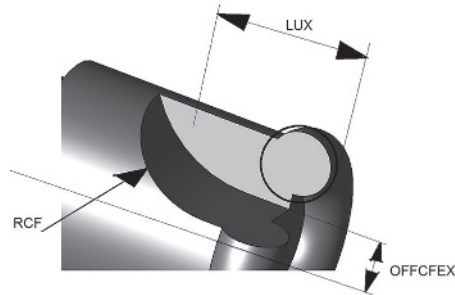

Figure 40 — Chip flute

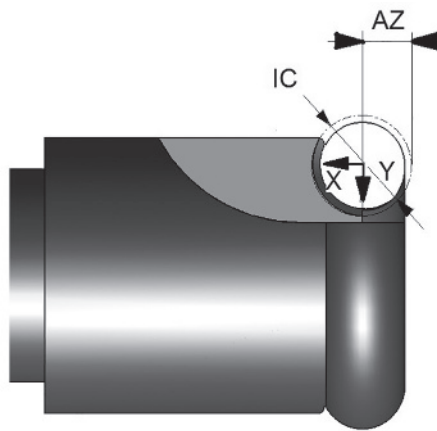

Figure 41 — Pocket seat

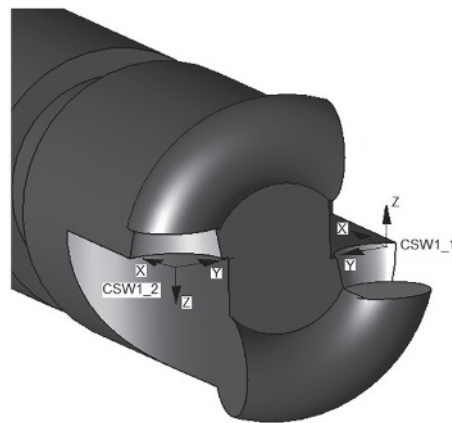

Figure 42 — Position of CSWs

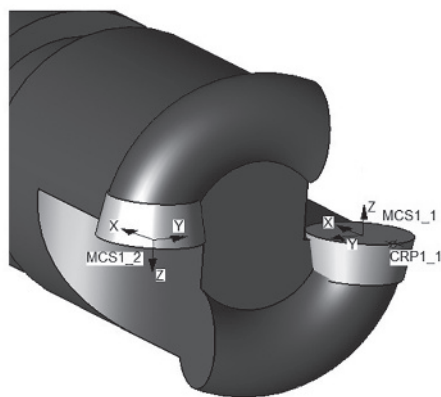

Figure 43 — Position of CRPs

9.6 Assembly of a rounded end mill

The assembly of the end mill shall be done using the CSWs as shown in [Figure 44](#). The mounting coordinate system of the inserts, MCS_INSERT, shall be mated directly onto the corresponding coordinate system workpiece side, CSW_{x_y}.

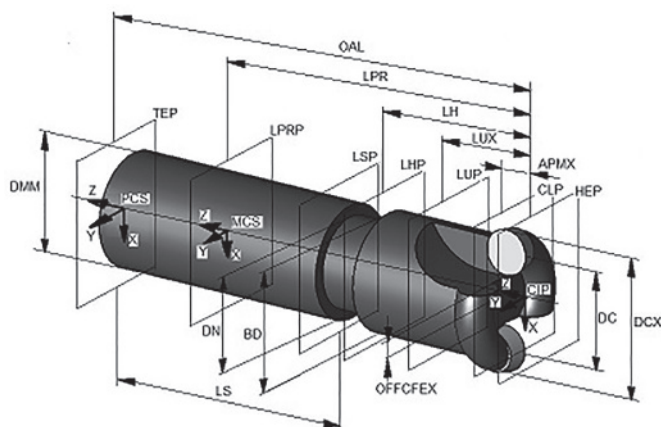

Figure 44 — Assembled rounded end mill

10 Threading end mill

10.1 General

[Figure 45](#) shows the properties to be used for the design of a threading end mill.

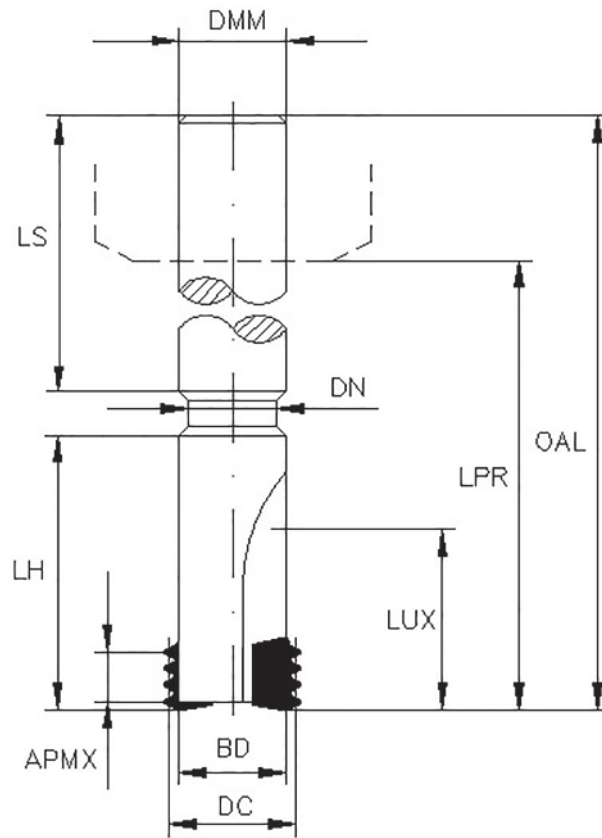

Figure 45 — Determination of properties of a threading end mill

10.2 Necessary properties

Table 9 lists the properties needed for the modelling of threading end mills.

Table 9 — Properties for the modelling of a threading end mill

Preferred name	Preferred symbol
depth of cut maximum	APMX
plunge depth maximum	AZ
body diameter	BD
cutting diameter	DC
shank diameter	DMM
neck diameter	DN
rake angle radial	GAMF
rake angle axial	GAMO
head length	LH
protruding length	LPR
shank length	LS
usable length maximum	LUX
overall length	OAL
face effective cutting edge count	ZEFF

Table 9 (continued)

Preferred name	Preferred symbol
face mounted insert count	ZNF

To determine the thread to be cut, it is recommended either to add the properties listed in [Table 10](#) to the parameters of the model or to create a separate table for this information.

Table 10 — Additional properties to classify the thread

Preferred name	Preferred symbol
thread form type	THFT
thread pitch	TP
threads per inch	TPI

10.3 Basic geometry

The structure of the model is described in [5.3](#) and is in accordance with [Figures 11](#) and [46](#).

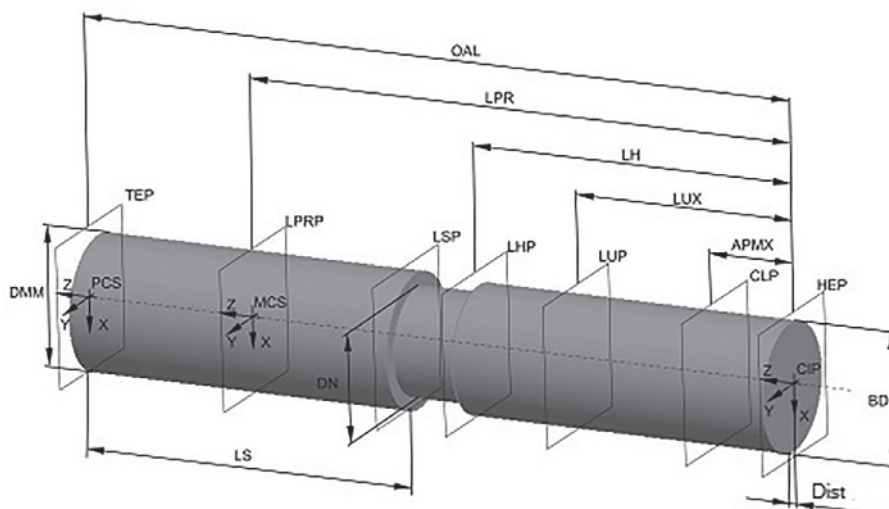

Figure 46 — Basic geometry of a threading end mill

In the case of threading end mills, the parameter “Dist” is a function of the insert properties “insert thickness” (S), “clearance angle minor” (ANN) and an offset, which is in the range of 0,2 mm to 0,5 mm. It is calculated using Formula (2):

$$\text{Dist} = S \times \tan(\text{ANN}) + \text{offset} \quad (2)$$

10.4 Determination of the position of the mounting coordinate system of insert

[Figure 47](#) shows the location of the CSWs.

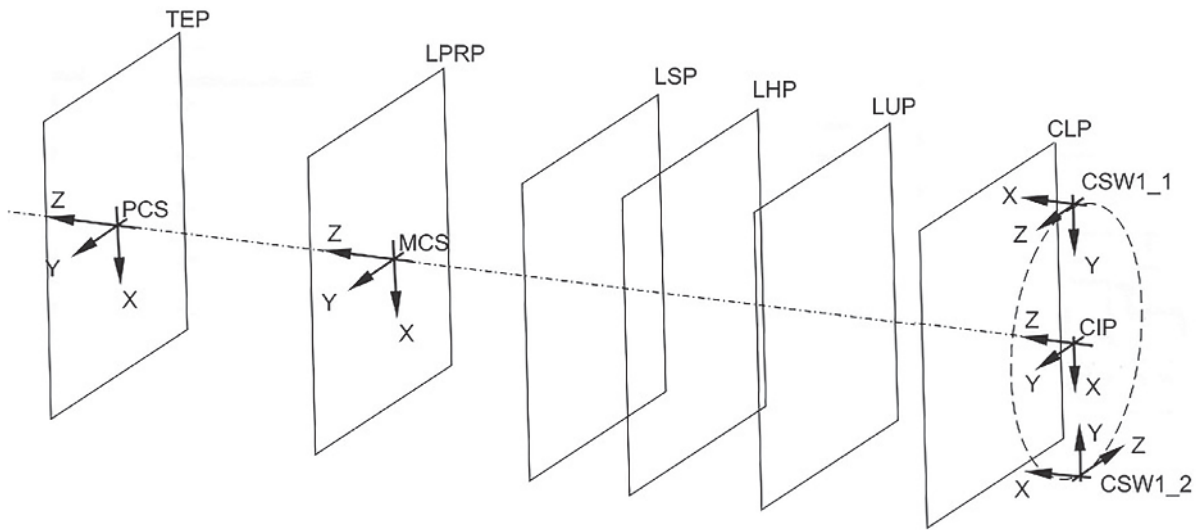

Figure 47 — Location of CSW_{x_y}

10.5 Chip flute and pocket seat

See 5.5 for the modelling of the chip flute and the pocket seat. The chip flute shall be designed according to the used insert shape and the maximum usable length. Figure 48 shows the location of the chip flutes and Figure 49 shows the location of the pocket seat.

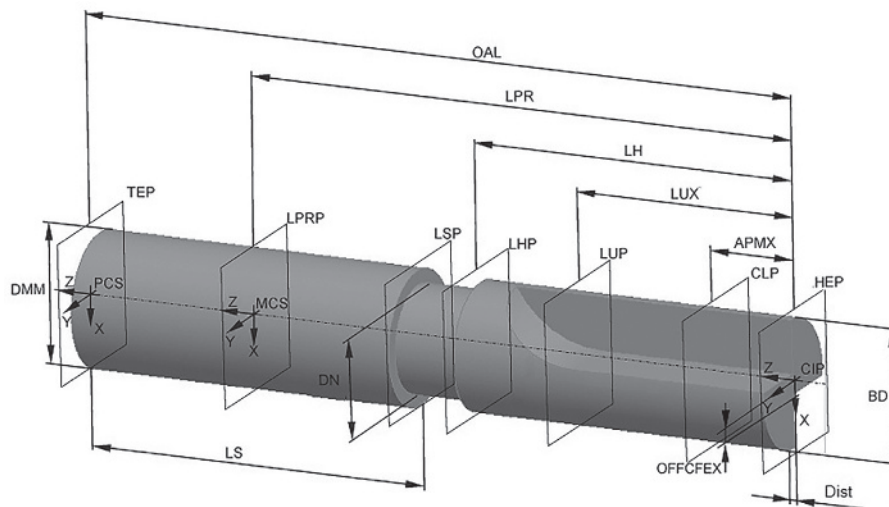

Figure 48 — Threading end mill: Chip flute

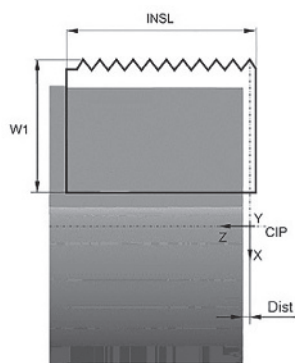

Figure 49 — Threading end mill: Pocket seat

After placing the pocket seat on to the tool body using the CSWs and CRPs, results are shown in [Figures 50](#) and [51](#).

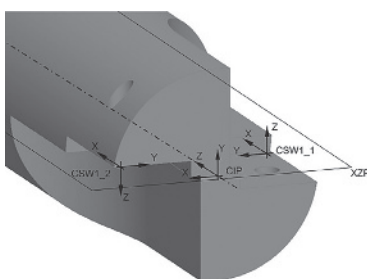

Figure 50 — Position of CSWs

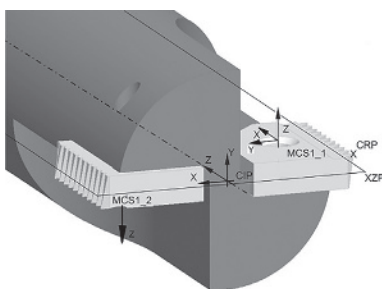

Figure 51 — Position of CRPs

10.6 Assembled threading end mill

The assembly of the end mill shall be done using the CSWs. The mounting coordinate system of the inserts, MCS_INSERT, shall be mated directly on to the corresponding coordinate system workpiece side, CSW_{x_y}. The assembly is shown in [Figure 52](#).

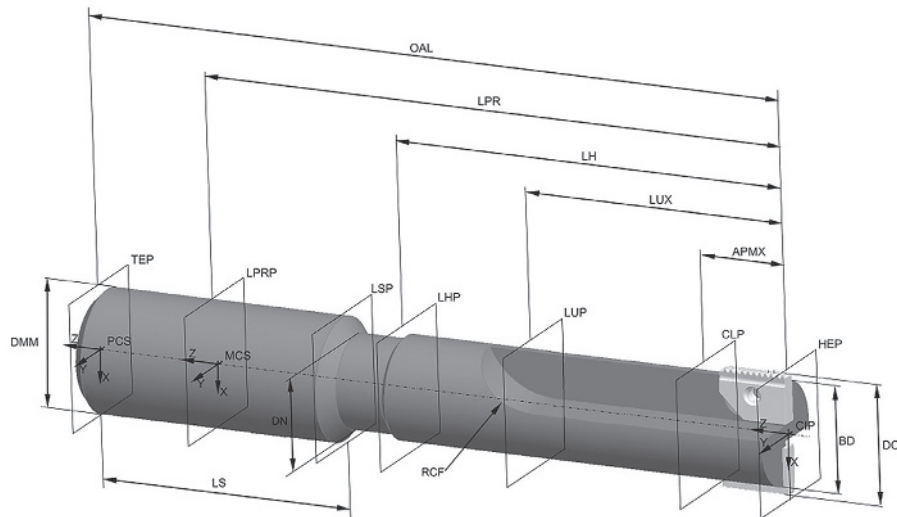

Figure 52 — Assembly of a threading end mill

11 End mill, non-centre-cutting, multiple rows

11.1 General

Figure 53 shows the properties to be used for the design of a multi-rows, non-centre-cutting end mill.

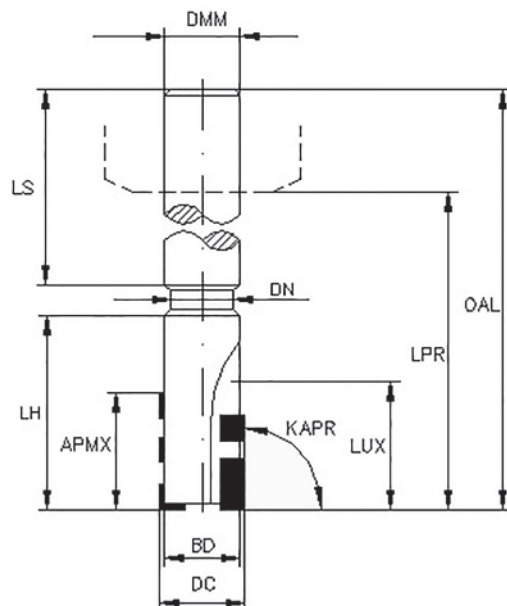

Figure 53 — Determination of properties of a multi-rows, non-centre-cutting end mill

11.2 Necessary properties

Table 11 lists the properties needed for the modelling of multi-rows, non-centre cutting end mills.

Table 11 — Properties for the modelling of multi-rows, non-centre-cutting end mill

Preferred name	Preferred symbol
depth of cut maximum	APMX
plunge depth maximum	AZ
body diameter	BD
cutting diameter	DC
shank diameter	DMM
neck diameter	DN
rake angle radial	GAMF
rake angle axial	GAMP
tool cutting edge angle	KAPR
head length	LH
protruding length	LPR
shank length	LS
usable length maximum	LUX
row count	NOR
overall length	OAL
face effective cutting edge count	ZEFF
peripheral effective cutting edge count	ZEFP
face mounted insert count	ZNF
peripheral mounted insert count	ZNP

11.3 Basic geometry

The structure of the model is described in [5.3](#) and is in accordance with [Figures 11](#) and [54](#).

11.4 Determination of the position of the mounting coordinate system of insert

[Figures 54](#) and [55](#) show the dependency between the rows and the CSWs. The only special case in this Clause is the value of the tool cutting edge angle, KAPR, which is 90°.

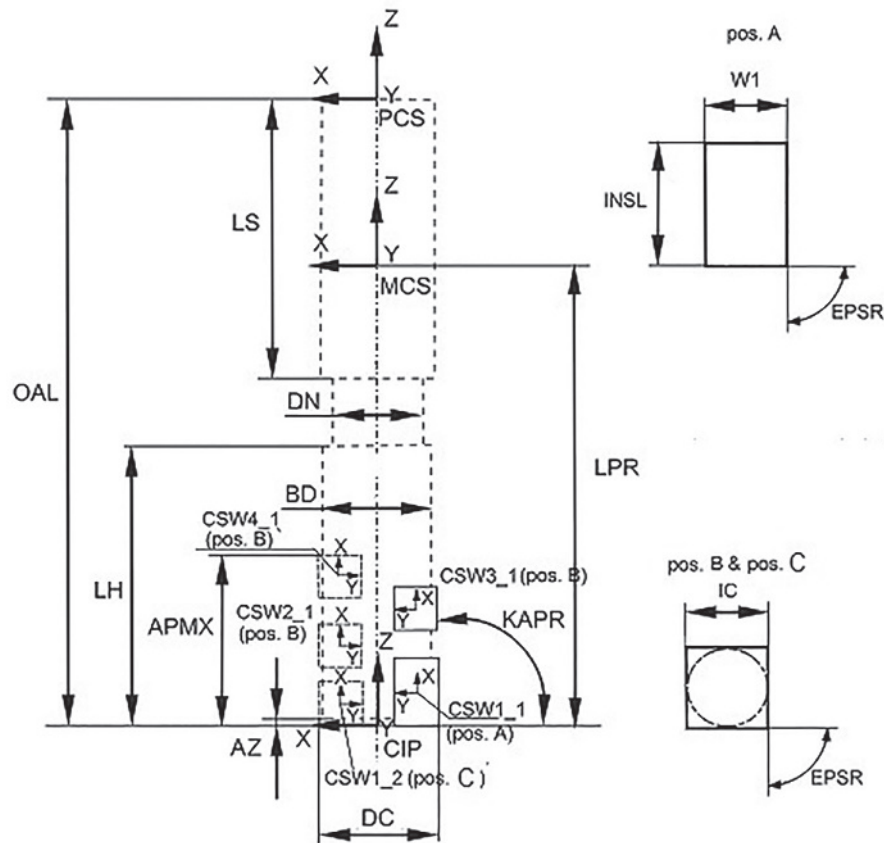

Figure 54 — Determination of CSW_{x_y} of a multi-rows end mill

For the position of the CSWs, it is important to use only the part of the cutting edge without any corner configuration, e.g. the straight portion of the cutting edge without the corner radius. To avoid any gap between the different rows, it is recommended to calculate with 75 % of the usable cutting edge length to get a correct arrangement of the cutting edges along the maximum cutting depth.

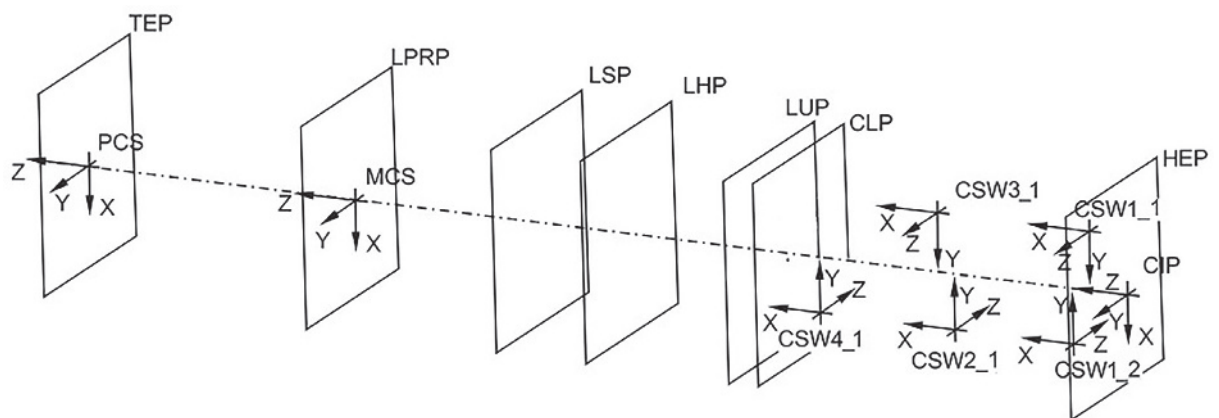

Figure 55 — Location of CSW_{x_y}

Figures 54 and 55 may also be valid for end mills described in [Clauses 12, 13, 15 and 16](#).

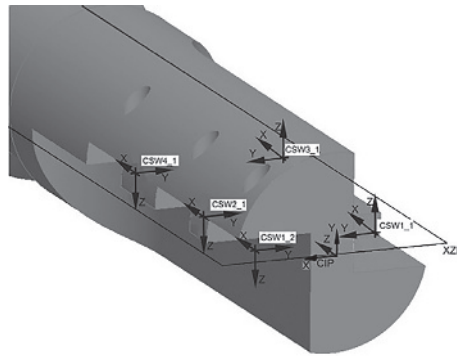

Figure 58 — Position of CSWs

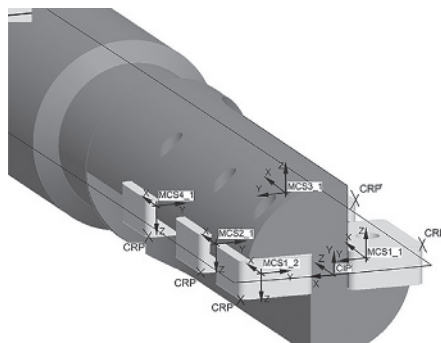

Figure 59 — Position of CRPs

11.6 Multiple rows, non-centre-cutting end mill assembly

The assembly of the end mill shall be done using the CSWs as shown in [Figure 60](#). The mounting coordinate system of the inserts, MCS_INSERT, shall be mated directly onto the corresponding coordinate system workpiece side, CSW_{x_y}.

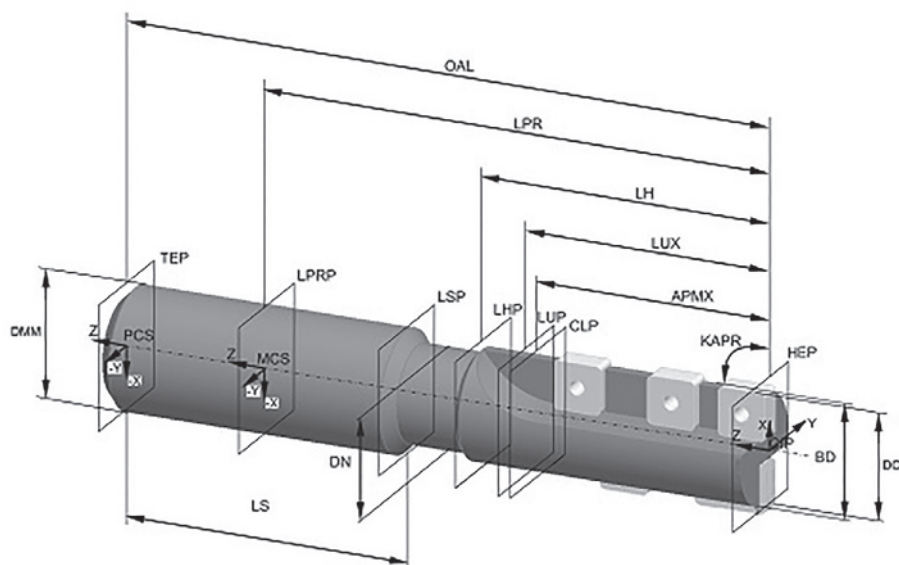

Figure 60 — Assembled multiple rows, non-centre cutting end mill

12 Angular end mill, non-centre-cutting, multiple rows

12.1 General

Figure 61 shows the properties to be used for the design of a multi-rows, non-centre-cutting angular end mill.

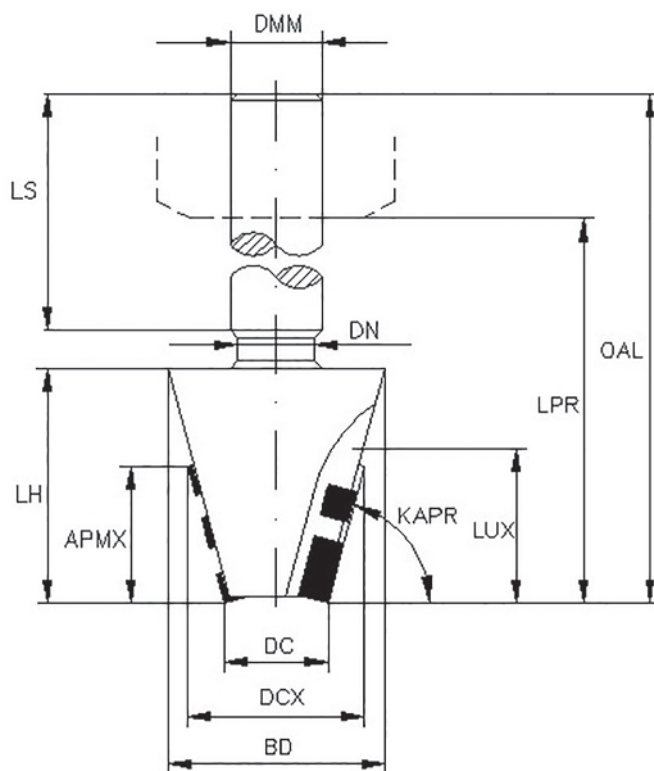

Figure 61 — Determination of properties of angular end mills

12.2 Necessary properties

Table 12 lists the properties needed for the modelling of multi-rows, non-centre cutting angular end mills.

Table 12 — Properties for the modelling of a multi-rows, non-centre cutting angular end mill

Preferred name	Preferred symbol
depth of cut maximum	APMX
plunge depth maximum	AZ
body diameter	BD
cutting diameter	DC
cutting diameter maximum	DCX
shank diameter	DMM
neck diameter	DN
rake angle radial	GAMF
rake angle axial	GAMO
tool cutting edge angle	KAPR
head length	LH

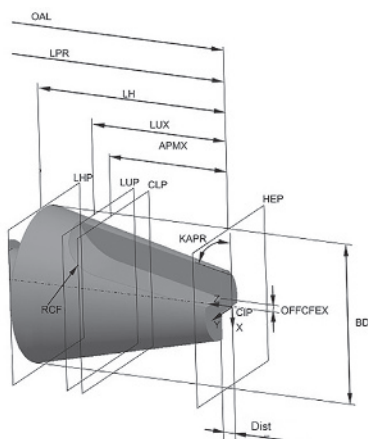

Figure 63 — Determination of the chip flutes

12.6 Multiple rows non-centre-cutting angular end mill assembly

The assembly of the end mill shall be done using the CSWs. The mounting coordinate system of the inserts, MCS_INSERT, shall be mated directly onto the corresponding coordinate system workpiece side, CSW_{x_y}, as shown in Figure 64.

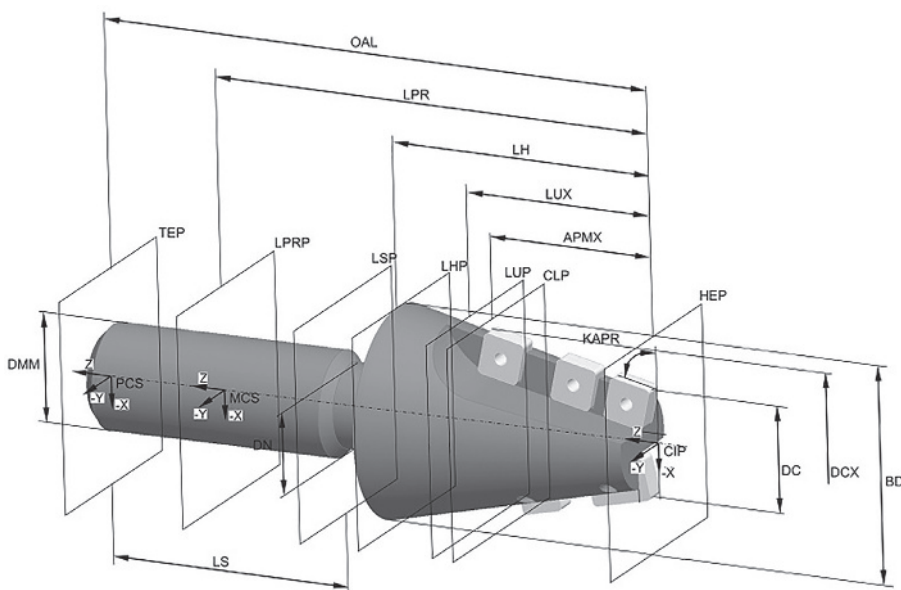

Figure 64 — Assembled non-centre cutting angular end mill

13 End mill, centre-cutting, multiple rows

13.1 General

Figure 65 shows the properties to be used for the design of a multi-rows, centre-cutting end mill.

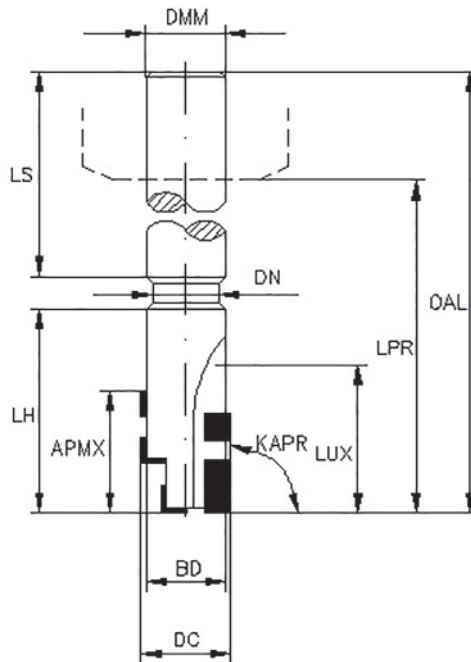

Figure 65 — Determination of properties of a centre cutting end mill

13.2 Necessary properties

See [11.2](#) for the necessary properties.

13.3 Basic geometry

The structure of the model is described in [5.3](#) and is in accordance with [Figures 11](#) and [66](#).

13.4 Determination of the position of the mounting coordinate system of insert

[Figure 66](#) shows the dependency between the rows and the CSWs. The only special case in this Clause is the position of the inner insert that cuts across the centre line.

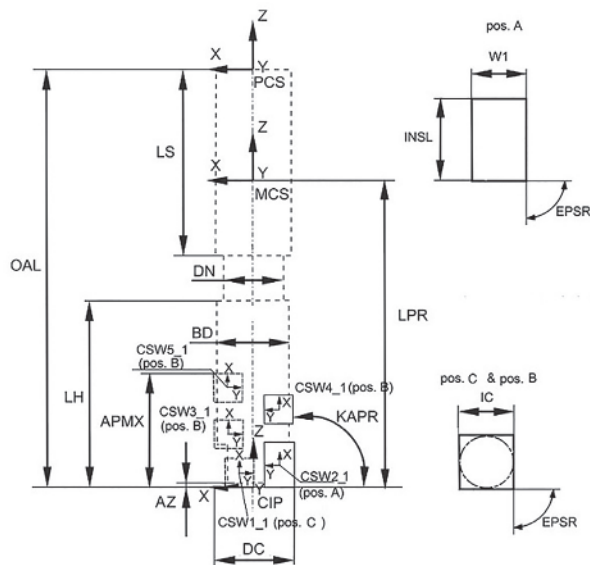

Figure 66 — Determination of CSW_{x_y} of a multi-rows, centre cutting end mill

Position A is determined as the outer position of the insert on the face. Position C is determined as the inner position of the insert on the face. Position B is determined as the position of any insert on the periphery.

13.5 Chip flute and pocket seat

See [Figures 67](#) to [70](#) for the arrangement of the inserts and the positions of CSWs and CRPs.

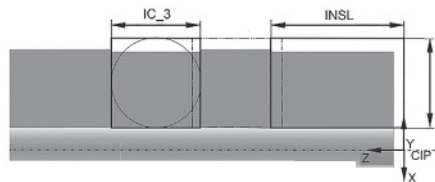

Figure 67 — Chip flute and outer pocket seats

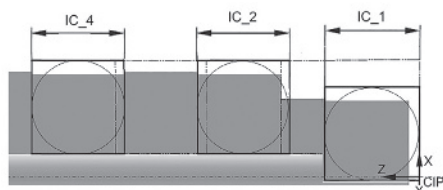

Figure 68 — Chip flute and inner pocket seat

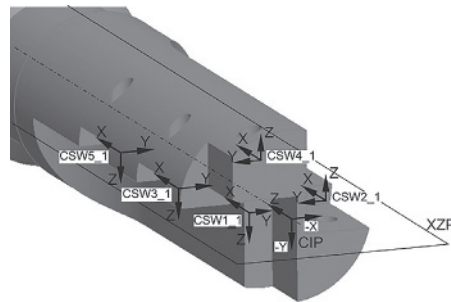

Figure 69 — Position of CSWs

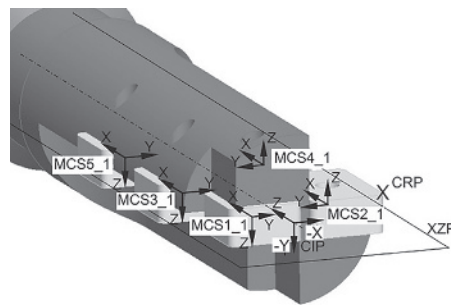

Figure 70 — Position of MCSs and CRP

13.6 Multiple rows, centre-cutting angular end mill assembly

The assembly of the end mill shall be done using the CSWs as shown in [Figure 71](#). The mounting coordinate system of the inserts, MCS_INSERT, shall be mated directly onto the corresponding coordinate system workpiece side, CSW_{x_y}.

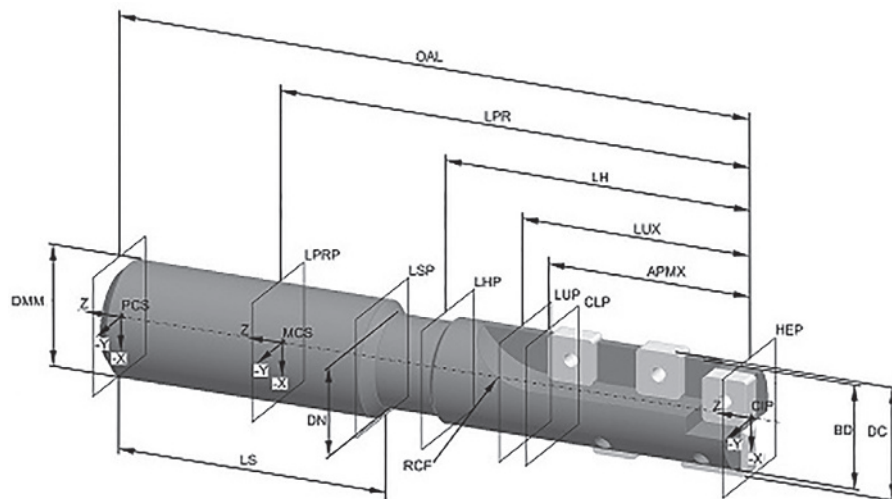

Figure 71 — Assembled multi-rows, centre cutting end mill

14 Spot-facing end mill

14.1 General

Figure 72 shows the properties to be used for the design of a spot-facing end mill.

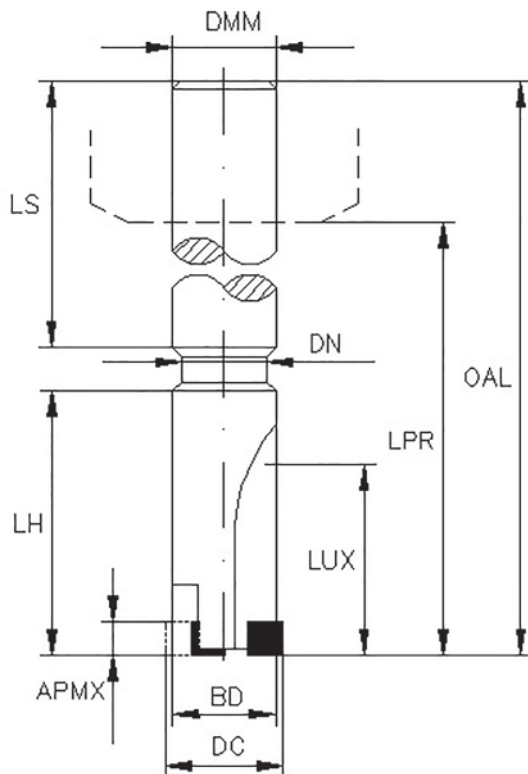

Figure 72 — Determination of properties of spot-facing end mills

14.2 Necessary properties

Table 13 lists the properties needed for the modelling of spot-facing end mills.

Table 13 — Properties for the modelling of a spot-facing end mill

Preferred name	Preferred symbol
depth of cut maximum	APMX
body diameter	BD
cutting diameter	DC
shank diameter	DMM
neck diameter	DN
rake angle radial	GAMF
rake angle axial	GAMO
head length	LH
protruding length	LPR
shank length	LS
usable length maximum	LUX

Table 13 (continued)

Preferred name	Preferred symbol
overall length	OAL
face effective cutting edge count	ZEFF
face mounted insert count	ZNF

14.3 Basic geometry

The structure of the model is described in 5.3 and is in accordance with Figures 11 and 73.

14.4 Determination of the position of the mounting coordinate system of insert

Figure 73 shows the dependency between the rows and the CSWs.

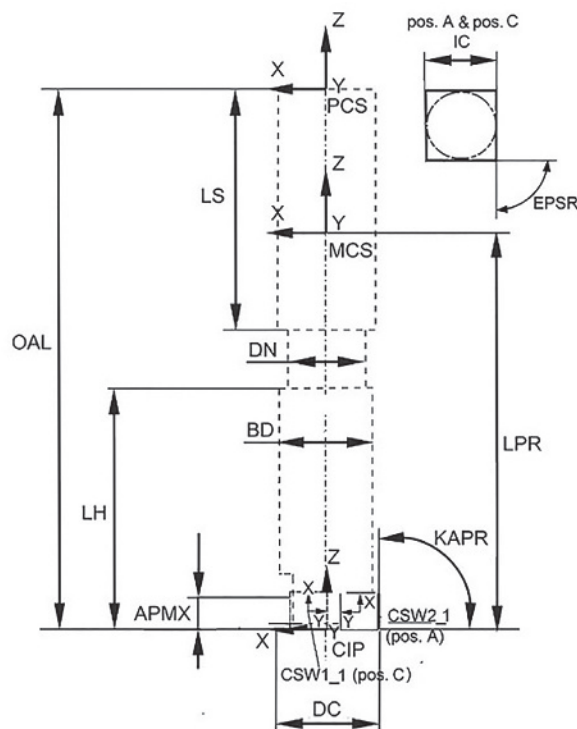

Figure 73 — Determination of CSW_{x_y} of a spot-facing end mill

Position A is determined as the outer position of the insert on the face. Position C is determined as the inner position of the insert on the face.

14.5 Chip flute and pocket seat

See 5.5 and Figures 74 to 77 for the modelling of the chip flute and the pocket seat. The chip flute shall be designed according to the used insert shape and the maximum usable length.

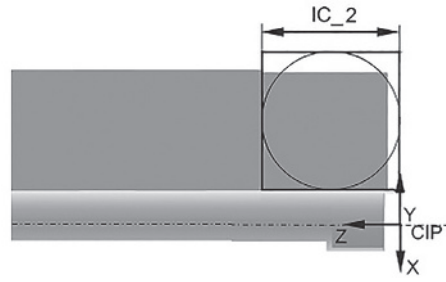

Figure 74 — Chip flute and outer pocket seat

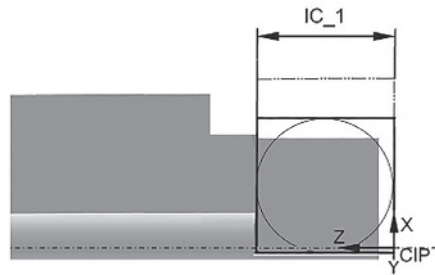

Figure 75 — Chip flute and inner pocket seat

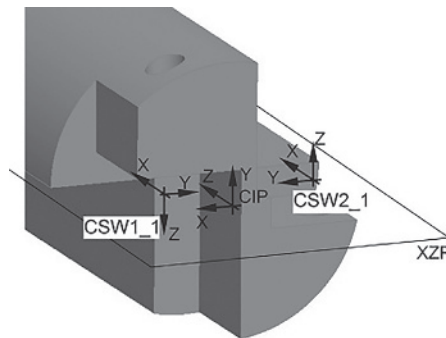

Figure 76 — Determination of CSWs

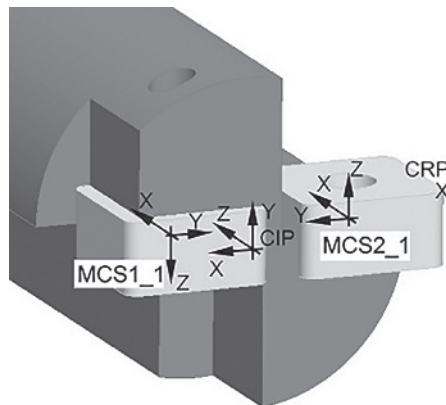

Figure 77 — Determination of MCSs and CRP

15.2 Necessary properties

Table 14 lists the properties being needed for the modelling of straight ball-nosed end mills.

Table 14 — Properties for the modelling of a straight ball-nosed end mill

Preferred name	Preferred symbol
depth of cut maximum	APMX
body diameter	BD
cutting diameter	DC
shank diameter	DMM
neck diameter	DN
rake angle radial	GAMF
rake angle axial	GAMO
tool cutting edge angle	KAPR
head length	LH
protruding length	LPR
shank length	LS
usable length maximum	LUX
row count	NOR
overall length	OAL
profile radius	PRFRAD
face effective cutting edge count	ZEFF
peripheral effective cutting edge count	ZEFP
face mounted insert count	ZNF
peripheral mounted insert count	ZNP

15.3 Basic geometry

The structure of the model is described in 5.3 and is in accordance with Figures 11 and 80.

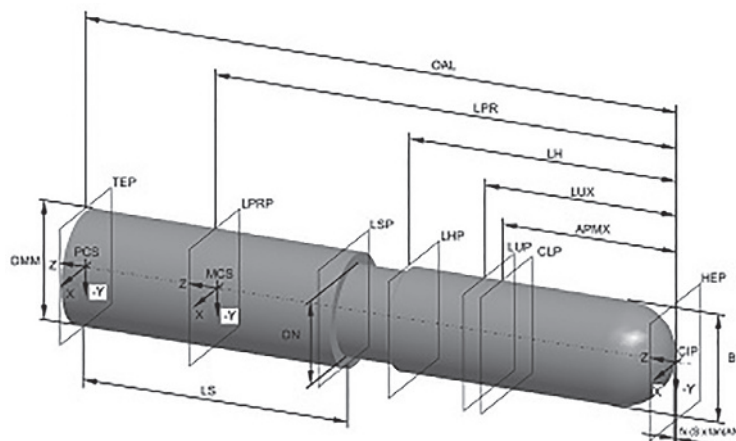

Figure 80 — Basic geometry of a ball-nosed end mill

15.4 Determination of the position of the mounting coordinate system of insert

Figures 81 and 82 show the determination and location of the positions of the coordinate system.

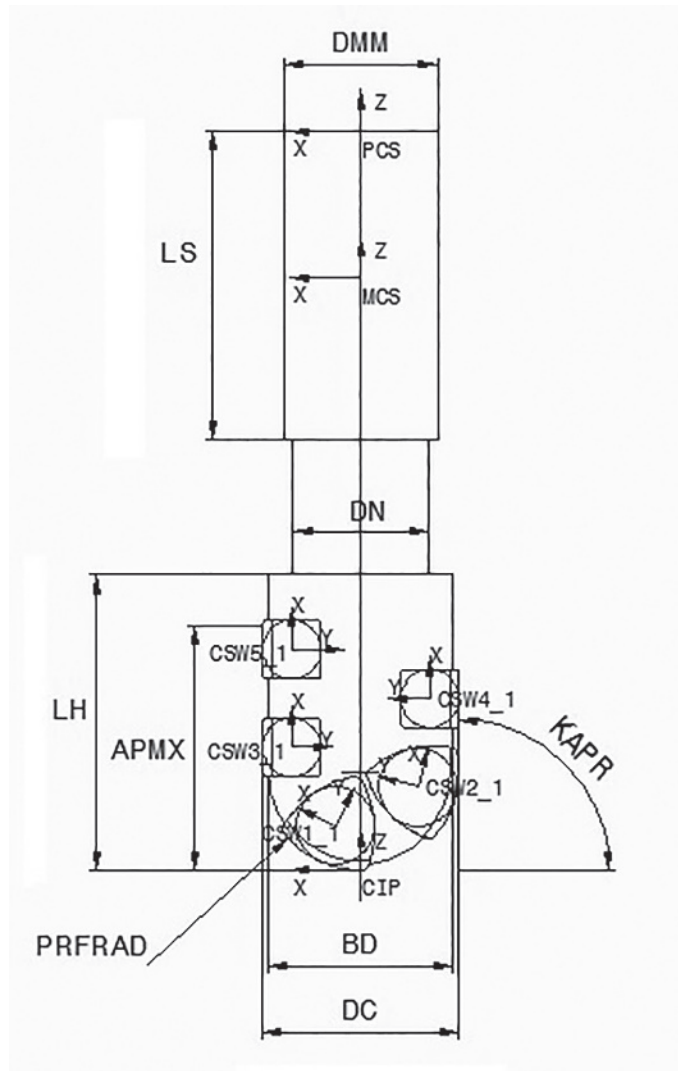

Figure 81 — Determination of CSWs of a ball-nosed straight end mill

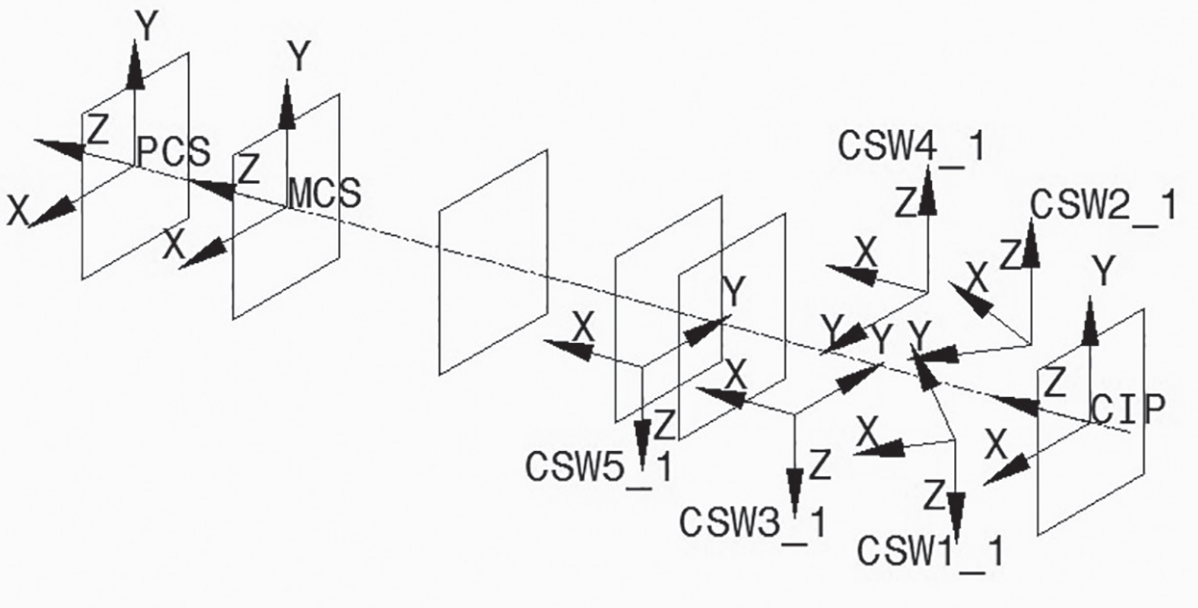

Figure 82 — Location of CSWs of a ball-nosed straight end mill

15.5 Chip flute and pocket seat

Position A is determined as the outer position of the insert on the face that cuts the profile radius from the periphery. Position C is determined as the inner position of the insert on the face that cuts the profile radius from the centre line. Position B is determined as the position of any insert on the periphery, which does not form the ball-nosed profile.

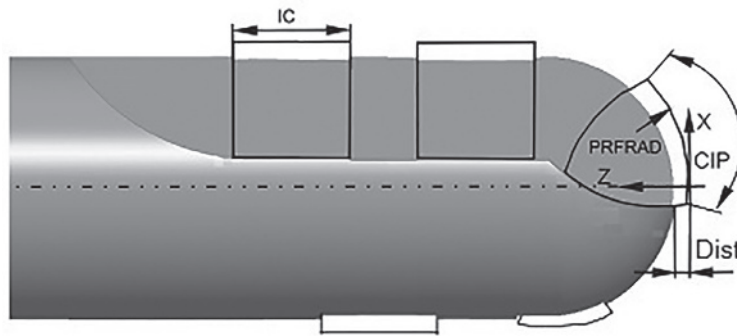

Figure 83 — Chip flute design with inner pocket

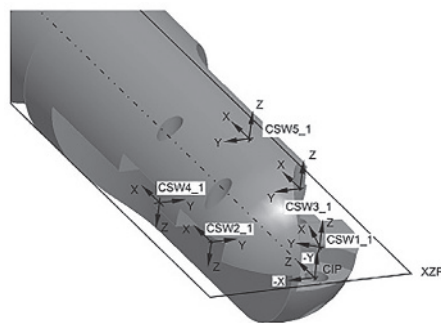

Figure 84 — Position of CSWs

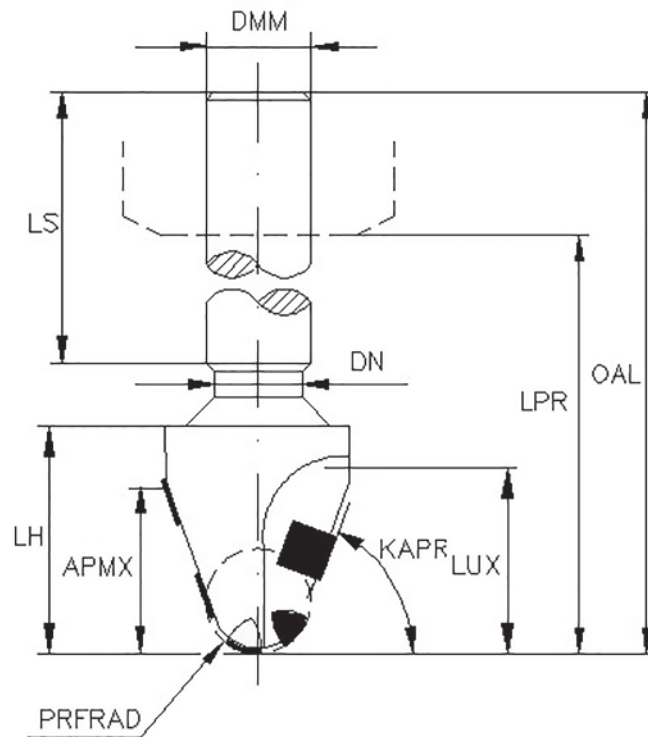

Figure 87 — Determination of properties of angular ball-nosed end mills

16.2 Necessary properties

See [15.2](#) for necessary properties.

16.3 Basic geometry

The structure of the model is described in [5.3](#) and is in accordance with [Figures 11](#) and [80](#).

16.4 Determination of the position of the mounting coordinate system of insert

See [15.4](#) and [Figures 81](#) and [82](#) for the determination of the positions of the coordinate systems.

16.5 Chip flute and pocket seat

See [15.5](#) and [Figures 83](#) to [85](#) for the design and determination of the chip flutes and the different pocket seats, as well as the mounting of the inserts.

16.6 Angular ball-nosed end mill assembly

See [15.6](#) for the illustration of the assembly of the end mill.

17 Die and mould end mill

17.1 General

[Figure 88](#) shows the properties to be used for the design of a die and mould end mill.

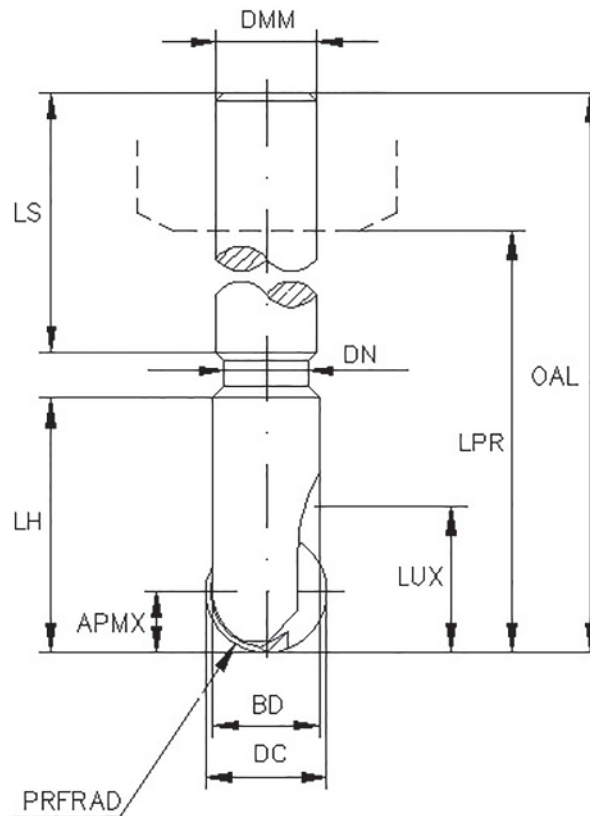

Figure 88 — Determination of properties of die and mould end mills

17.2 Necessary properties

[Table 15](#) lists the properties needed for the modelling of die and mould end mills.

Table 15 — Properties for the modelling of a die and mould end mill

Preferred name	Preferred symbol
depth of cut maximum	APMX
body diameter	BD
cutting diameter	DC
shank diameter	DMM
neck diameter	DN
head length	LH
protruding length	LPR
shank length	LS
usable length maximum	LUX
overall length	OAL
profile radius	PRFRAD
face effective cutting edge count	ZEFF
face mounted insert count	ZNF

17.3 Basic geometry

The structure of the model is described in 5.3 and is in accordance with Figures 11 and 89.

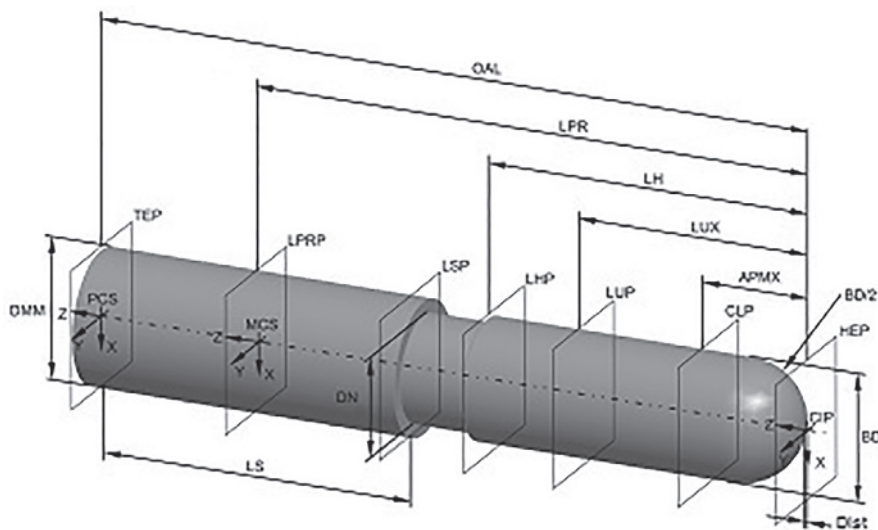

Figure 89 — Basic geometry of a die and mould end mill

17.4 Determination of the position of the mounting coordinate system of insert

Figure 90 shows the location of the CSW.

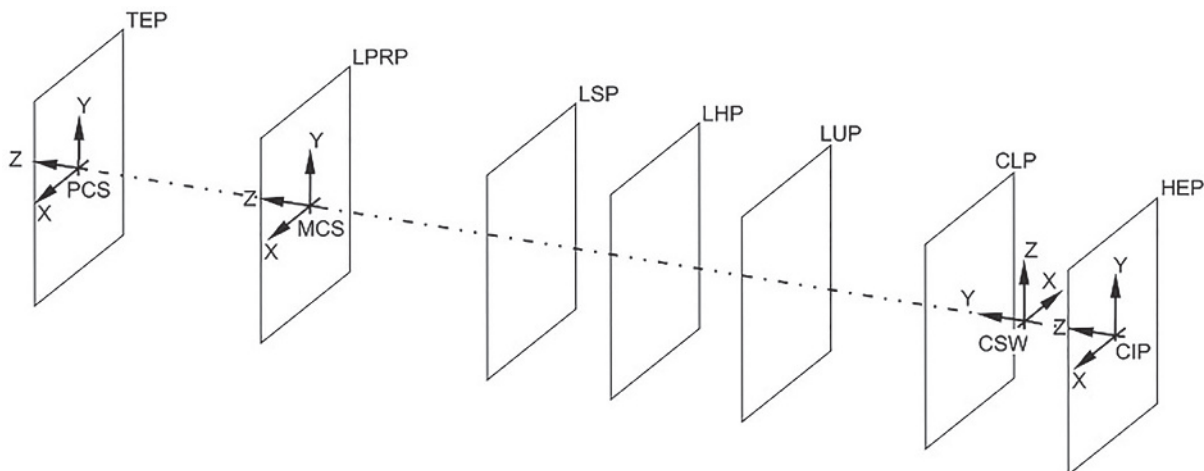

Figure 90 — Location of CSW

17.5 Chip flute and pocket seat

To get enough clearance and room for the removed material, it is recommended to design the chip flute as shown in Figure 91 and in Figure 92. The entire flute shall be located from the tool centre with its offset value of "OFFCFEX". The flute shall start at the centre on the front end with an inclination to the virtual intersection between the x-axis of CSW and a line parallel to the tool axis with the distance of OFFCFEX.

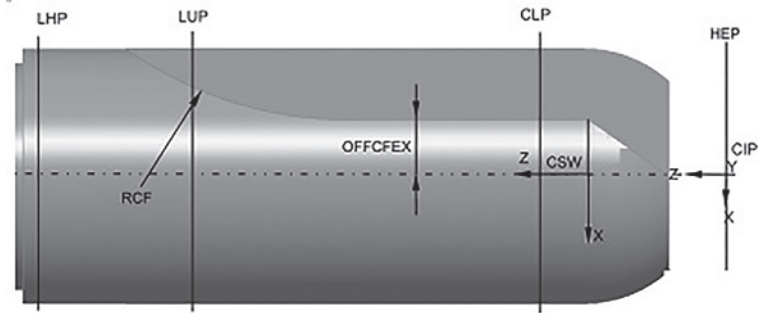

Figure 91 — Design of the chip flute

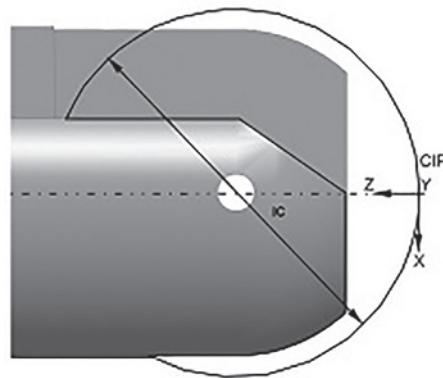

Figure 92 — Design of the pocket seat

The pocket seat is designed as a single slot through the tool body parallel to the xz -plane of the PCS. The slot shall have the nominal width that is equal to the insert thickness. [Figures 93](#) and [94](#) show the position of the CSW and the CRP.

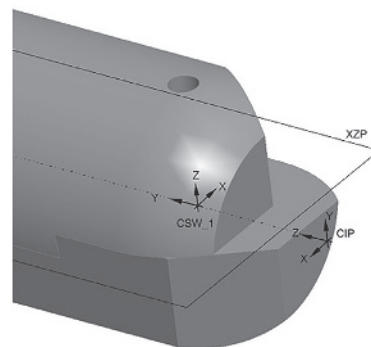

Figure 93 — Position of CSW

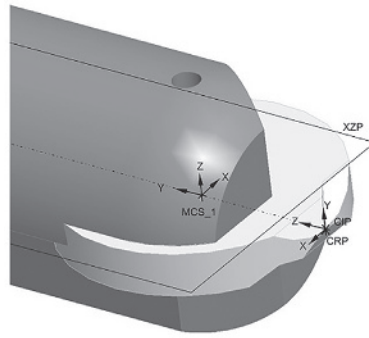

Figure 94 — Position of MCS and CRP

17.6 Die end mill assembly

Figure 95 shows the assembled die and mould end mill.

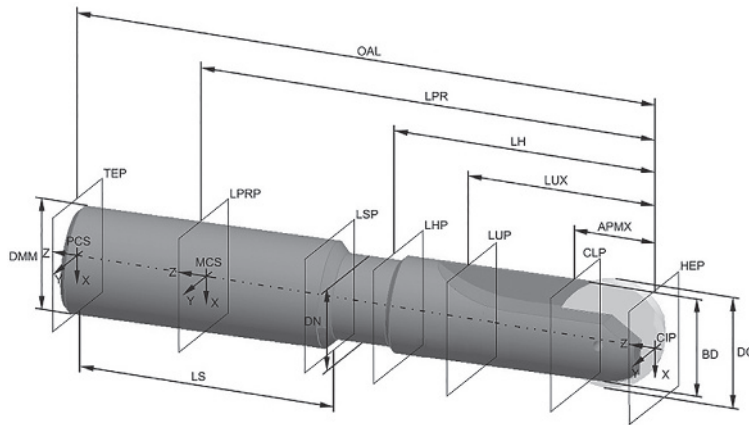

Figure 95 — Assembled die and mould end mill

18 Bell-style end mill

18.1 General

Figure 96 shows the properties to be used for the design of a bell-style end mill.

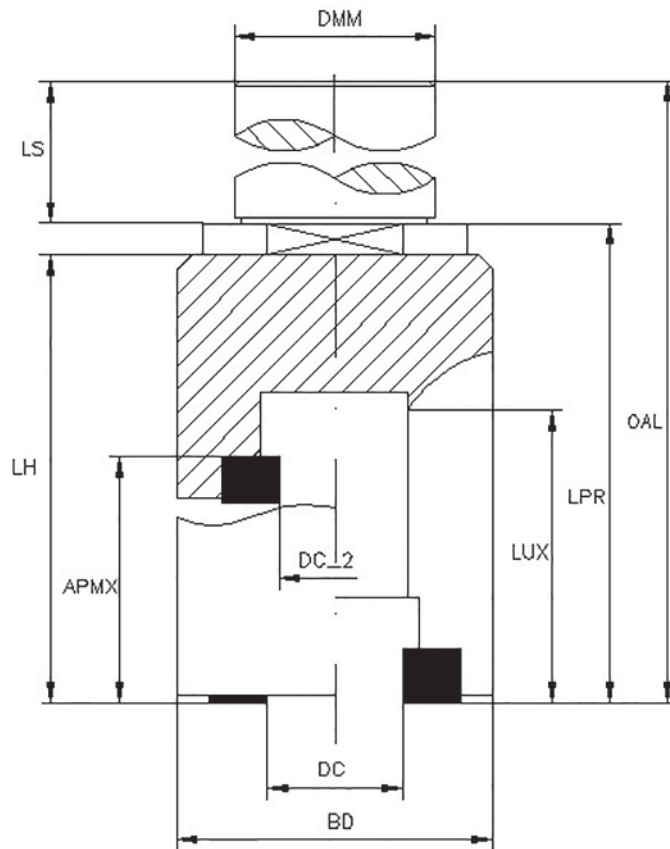

Figure 96 — Determination of properties of bell-style end mills

18.2 Necessary properties

Table 16 lists the properties needed for the modelling of bell-style end mills.

Table 16 — Properties for the modelling of a bell-style end mill

Preferred name	Preferred symbol
depth of cut maximum	APMX
body diameter	BD
cutting diameter	DC
cutting diameter 2	DC_2
shank diameter	DMM
neck diameter	DN
rake angle radial	GAMF
rake angle axial	GAMO
tool cutting edge angle	KAPR
head length	LH
protruding length	LPR
usable length maximum	LUX
row count	NOR

Table 16 (continued)

Preferred name	Preferred symbol
overall length	OAL
profile radius	PRFRAD
face effective cutting edge count	ZEFF
peripheral effective cutting edge count	ZEFP
face mounted insert count	ZNF
peripheral mounted insert count	ZNP

18.3 Basic geometry

The structure of the model is described in 5.3 and is in accordance with Figures 11 and 89.

Figure 97 shows the basic geometry of a bell-style end mill.

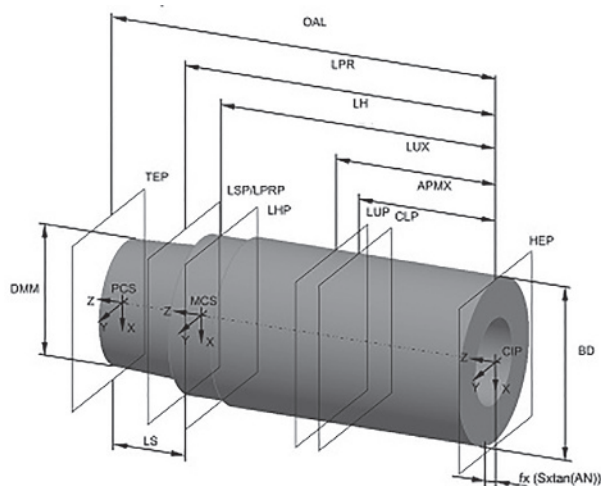

Figure 97 — Basic geometry of a bell-style end mill

18.4 Determination of the position of the mounting coordinate system of insert

Figure 98 shows the designation of the CSWs.

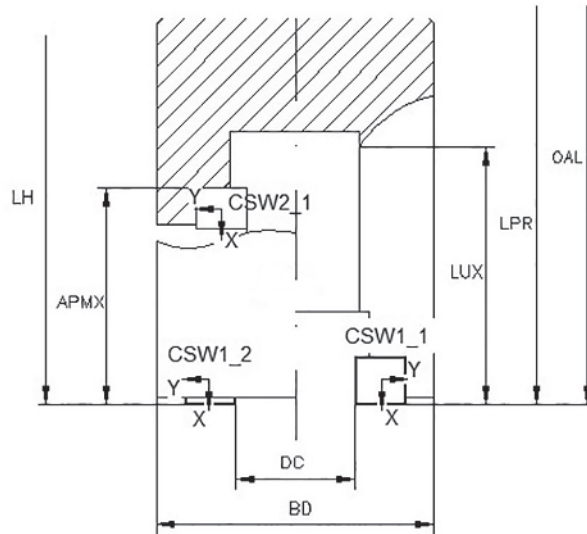

Figure 98 — Position of CSWs

18.5 Chip flute and pocket seat

See 11.5 for the modelling of the chip flute and pocket seats.

18.6 Bell-style end mill assembly

Figure 99 illustrates an assembled bell-style end mill.

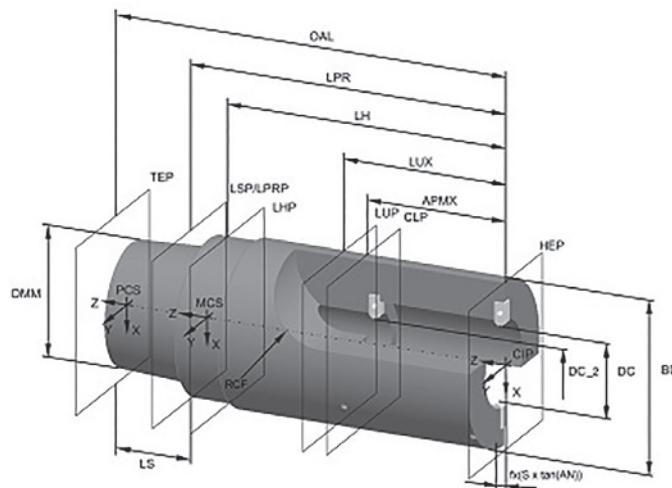

Figure 99 — Assembled bell-style end mill

19 Design of details

19.1 Basis for modelling

All details shall be designed as separate design features and shall not be incorporated into the revolved body of the crude geometry.

19.2 Fixing threads for inserts

Internal threads for the fastening of the inserts shall not be designed as details because they are not relevant for collision.

19.3 Contact/clamping surfaces — Orientation

Clamping surfaces which shall be visualized within the tool model shall be orientated by means of a unique orientation. The normal of the face shall be parallel with the “+Y”-axis of the primary coordinate system “PCS” as shown in [Figure 100](#).



Figure 100 — Orientation of planar/clamping surfaces

19.4 Chamfers and roundings

Necessary chamfers and roundings shall be created within the appropriate functions of the 3D CAD system.

20 Attributes of surfaces — Visualization of the model features

For a printed version of this part of ISO/TS 13399, the colour settings as part of the attributes of the surfaces shall be taken in accordance with ISO/TS 13399-80.

NOTE 1 Some CAD systems identify only one surface of the same diameter even if these surfaces are mated by means of two solid design features. Therefore, to address the surface attributes to each of these features, a revolved design feature is created over the cutting part feature. In the tree of elements and features, this element is called “CUTTING_SURFACE”. This design feature is created with the sketch elements of the cutting and non-cutting part and is placed at the end of the tree.

NOTE 2 Some CAD systems give the possibility to use the available lines of the main sketches for the creation of the “CUTTING_SURFACE”. Hereby, the datum planes, “LCFP”, and others, are used as references. With the deletion of the main design elements, all referenced design elements are also deleted.

21 Structure of the design elements (tree of model)

At end mills for indexable inserts, the inserts shall be defined as cutting features “CUT” only. The basic body of the cutting tool shall be defined as “NOCUT” design feature. The design features of the basic body shall be grouped within the group “BASIC”. Hereby, it is necessary that both groups can be suppressed or deactivated separately, without a mutual impact.

All the detailed design features shall be put together to a separate group named “DETAILS”. This group shall be the last element of the tree. It is dependent on the groups “CUT” and “NOCUT” and shall be deleted, if one of these two groups is deleted. See [Figure 101](#).

Such kind of grouping shall be built only if the containing design features are arranged consecutively. Therefore, care shall be taken for the correct sequence of the design features with notice to avoid reference.

The structure shall be as shown in [Figure 101](#). It shall be similar in other CAD systems.

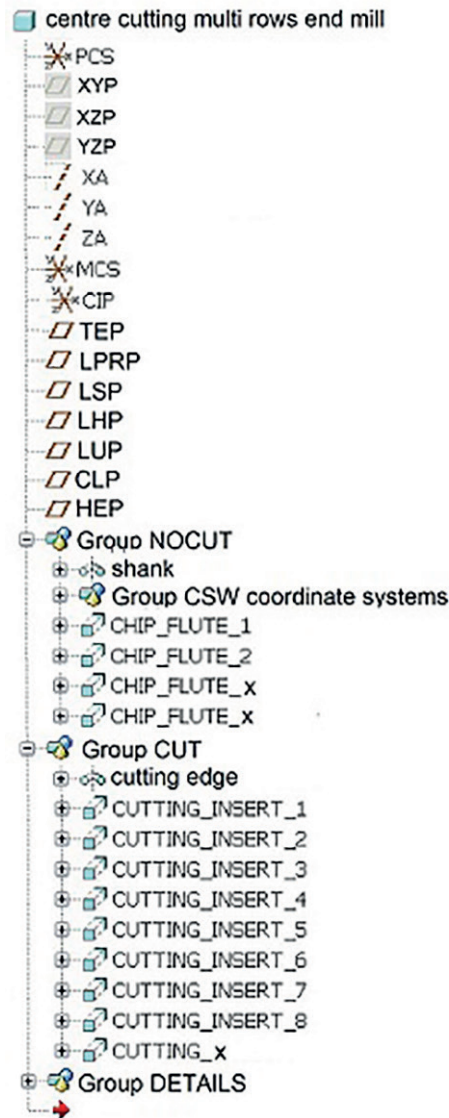

Figure 101 — Example of the structure of design features

22 Data exchange model

Examples of the data exchange model of a single row, non-centre-cutting end mill and of a T-slotting end mill are shown in [Figures 102](#) and [103](#). All of these models shall contain the geometrical features (collision contour), primary coordinate system “PCS”, the mounting coordinate system “MCS”, the coordinate system in process “CIP” and the cutting line of the inserts that are relevant for the collision examination.

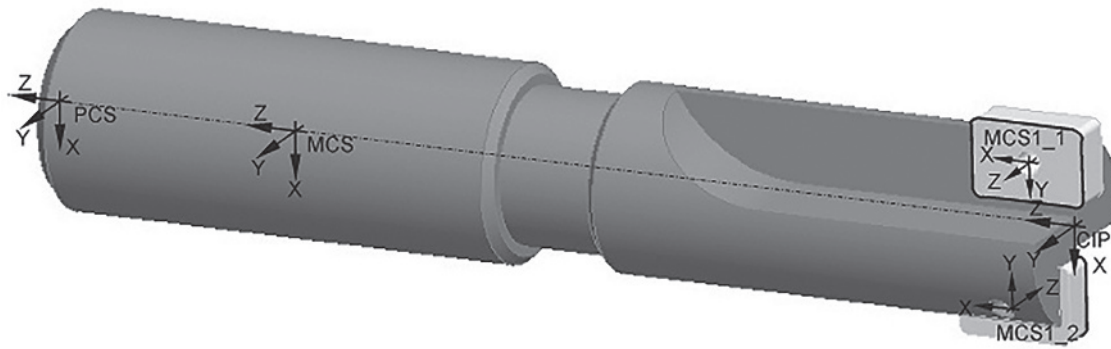

Figure 102 — Example of a data exchange model of a non-centre cutting end mill

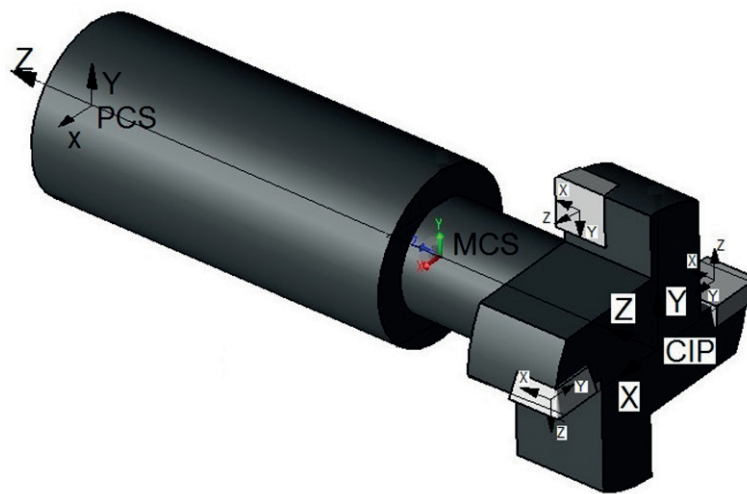

Figure 103 — Example of a data exchange model of a T-slotting end mill

Annex A (informative)

Information about nominal dimensions

A nominal dimension, a nominal size or a trade size is a size “in name only” used for identification. The nominal size may not match any dimension of the product, but within the domain of that product, the nominal size may correspond to a large number of highly standardized dimensions and tolerances. A nominal size may not even carry any unit of measure.

In measurement, a nominal value is often a value existing in name only. It is assigned as a convenient designation rather than calculated by data analysis or following usual rounding methods. The use of nominal values can be based on de facto standards or some technical standards.

All real measurements have some variation depending on the accuracy and precision of the production method and the measurement uncertainty. The use of reported values often involves engineering tolerances.

Table A.1 — Examples of nominal dimensions/sizes

Description	Value	Tolerance	Lower limit	Upper limit	Nominal dimension/ size
Morse taper size 5	MT5	—	—	—	5
Internal diameter	∅ 25	H6	25,000	25,013	25,000
External diameter	∅ 25	g7	24,972	24,993	25,000
Square shank size h×b	32×25	h13	31,61×24,67	32×25	32×25

Bibliography

- [1] ISO 13399-1, *Cutting tool data representation and exchange — Part 1: Overview, fundamental principles and general information model*
- [2] ISO/TS 13399-2, *Cutting tool data representation and exchange — Part 2: Reference dictionary for the cutting items*
- [3] ISO/TS 13399-5, *Cutting tool data representation and exchange — Part 5: Reference dictionary for assembly items*
- [4] ISO/TS 13399-70, *Cutting tool data representation and exchange — Part 70: Graphical data layout — Layer settings for tool designs*
- [5] ISO/TS 13399-100, *Cutting tool data representation and exchange — Part 100: Definitions, principles and methods for reference dictionaries*
- [6] ISO/TS 13399-150, *Cutting tool data representation and exchange — Part 150: Usage guidelines*
- [7] ISO 13584-24, *Industrial automation systems and integration — Parts library — Part 24: Logical resource: Logical model of supplier library*
- [8] ISO 13584-25, *Industrial automation systems and integration — Parts library — Part 25: Logical resource: Logical model of supplier library with aggregate values and explicit content*

British Standards Institution (BSI)

BSI is the national body responsible for preparing British Standards and other standards-related publications, information and services.

BSI is incorporated by Royal Charter. British Standards and other standardization products are published by BSI Standards Limited.

About us

We bring together business, industry, government, consumers, innovators and others to shape their combined experience and expertise into standards-based solutions.

The knowledge embodied in our standards has been carefully assembled in a dependable format and refined through our open consultation process. Organizations of all sizes and across all sectors choose standards to help them achieve their goals.

Information on standards

We can provide you with the knowledge that your organization needs to succeed. Find out more about British Standards by visiting our website at bsigroup.com/standards or contacting our Customer Services team or Knowledge Centre.

Buying standards

You can buy and download PDF versions of BSI publications, including British and adopted European and international standards, through our website at bsigroup.com/shop, where hard copies can also be purchased.

If you need international and foreign standards from other Standards Development Organizations, hard copies can be ordered from our Customer Services team.

Subscriptions

Our range of subscription services are designed to make using standards easier for you. For further information on our subscription products go to bsigroup.com/subscriptions.

With **British Standards Online (BSOL)** you'll have instant access to over 55,000 British and adopted European and international standards from your desktop. It's available 24/7 and is refreshed daily so you'll always be up to date.

You can keep in touch with standards developments and receive substantial discounts on the purchase price of standards, both in single copy and subscription format, by becoming a **BSI Subscribing Member**.

PLUS is an updating service exclusive to BSI Subscribing Members. You will automatically receive the latest hard copy of your standards when they're revised or replaced.

To find out more about becoming a BSI Subscribing Member and the benefits of membership, please visit bsigroup.com/shop.

With a **Multi-User Network Licence (MUNL)** you are able to host standards publications on your intranet. Licences can cover as few or as many users as you wish. With updates supplied as soon as they're available, you can be sure your documentation is current. For further information, email bsmusales@bsigroup.com.

Revisions

Our British Standards and other publications are updated by amendment or revision.

We continually improve the quality of our products and services to benefit your business. If you find an inaccuracy or ambiguity within a British Standard or other BSI publication please inform the Knowledge Centre.

Copyright

All the data, software and documentation set out in all British Standards and other BSI publications are the property of and copyrighted by BSI, or some person or entity that owns copyright in the information used (such as the international standardization bodies) and has formally licensed such information to BSI for commercial publication and use. Except as permitted under the Copyright, Designs and Patents Act 1988 no extract may be reproduced, stored in a retrieval system or transmitted in any form or by any means – electronic, photocopying, recording or otherwise – without prior written permission from BSI. Details and advice can be obtained from the Copyright & Licensing Department.

Useful Contacts:

Customer Services

Tel: +44 845 086 9001

Email (orders): orders@bsigroup.com

Email (enquiries): cservices@bsigroup.com

Subscriptions

Tel: +44 845 086 9001

Email: subscriptions@bsigroup.com

Knowledge Centre

Tel: +44 20 8996 7004

Email: knowledgecentre@bsigroup.com

Copyright & Licensing

Tel: +44 20 8996 7070

Email: copyright@bsigroup.com

BSI Group Headquarters

389 Chiswick High Road London W4 4AL UK

