

PD ISO/TR 25901-3:2016



BSI Standards Publication

# Welding and allied processes — Vocabulary

Part 3: Welding processes

**bsi.**

...making excellence a habit.™

**National foreword**

This Published Document is the UK implementation of ISO/TR 25901-3:2016.

The UK participation in its preparation was entrusted to Technical Committee WEE/1, Briefing committee for welding.

A list of organizations represented on this committee can be obtained on request to its secretary.

This publication does not purport to include all the necessary provisions of a contract. Users are responsible for its correct application.

© The British Standards Institution 2016. Published by BSI Standards Limited 2016

ISBN 978 0 580 86433 9

ICS 01.040.25; 25.160.10

**Compliance with a British Standard cannot confer immunity from legal obligations.**

This Published Document was published under the authority of the Standards Policy and Strategy Committee on 31 March 2016.

**Amendments issued since publication**

Date	Text affected
------	---------------

---

# TECHNICAL REPORT

# ISO/TR 25901-3

First edition  
2016-03-15

---

---

## Welding and allied processes — Vocabulary —

### Part 3: Welding processes

*Soudage et techniques connexes — Vocabulaire —*

*Partie 3: Procédés de soudage*



Reference number  
ISO/TR 25901-3:2016(E)

© ISO 2016



## **COPYRIGHT PROTECTED DOCUMENT**

© ISO 2016, Published in Switzerland

All rights reserved. Unless otherwise specified, no part of this publication may be reproduced or utilized otherwise in any form or by any means, electronic or mechanical, including photocopying, or posting on the internet or an intranet, without prior written permission. Permission can be requested from either ISO at the address below or ISO's member body in the country of the requester.

ISO copyright office  
Ch. de Blandonnet 8 • CP 401  
CH-1214 Vernier, Geneva, Switzerland  
Tel. +41 22 749 01 11  
Fax +41 22 749 09 47  
copyright@iso.org  
www.iso.org

# Contents

Page

<b>Foreword</b> .....	<b>iv</b>
<b>1 Scope</b> .....	<b>1</b>
<b>2 Terms and definitions</b> .....	<b>1</b>
2.1 Basic terms and definitions.....	1
2.2 Terms related to welding processes.....	2
2.2.1 Welding with pressure.....	2
2.2.2 Fusion welding.....	22
<b>Annex A (informative) Alphabetical index of English terms with French and German translations</b> .....	<b>38</b>
<b>Annex B (informative) Alphabetical index of welding processes related terms defined in ISO 857-1:1998 that were not included in this part of ISO/TR 25901</b> .....	<b>44</b>
<b>Bibliography</b> .....	<b>45</b>

## Foreword

ISO (the International Organization for Standardization) is a worldwide federation of national standards bodies (ISO member bodies). The work of preparing International Standards is normally carried out through ISO technical committees. Each member body interested in a subject for which a technical committee has been established has the right to be represented on that committee. International organizations, governmental and non-governmental, in liaison with ISO, also take part in the work. ISO collaborates closely with the International Electrotechnical Commission (IEC) on all matters of electrotechnical standardization.

The procedures used to develop this document and those intended for its further maintenance are described in the ISO/IEC Directives, Part 1. In particular the different approval criteria needed for the different types of ISO documents should be noted. This document was drafted in accordance with the editorial rules of the ISO/IEC Directives, Part 2 (see [www.iso.org/directives](http://www.iso.org/directives)).

Attention is drawn to the possibility that some of the elements of this document may be the subject of patent rights. ISO shall not be held responsible for identifying any or all such patent rights. Details of any patent rights identified during the development of the document will be in the Introduction and/or on the ISO list of patent declarations received (see [www.iso.org/patents](http://www.iso.org/patents)).

Any trade name used in this document is information given for the convenience of users and does not constitute an endorsement.

For an explanation on the meaning of ISO specific terms and expressions related to conformity assessment, as well as information about ISO's adherence to the WTO principles in the Technical Barriers to Trade (TBT) see the following URL: [Foreword - Supplementary information](#)

The committee responsible for this document is ISO/TC 44, *Welding and allied processes*, Subcommittee SC 7, *Representation and terms*, in collaboration with Commission VI, *Terminology, of the International Institute of Welding (IIW)*.

This first edition of ISO/TR 25901-3, together with the other parts of ISO/TR 25901, cancels and replaces ISO 857-1:1998 and ISO/TR 25901:2007, of which it constitutes a revision.

ISO/TR 25901 consists of the following parts, under the general title *Welding and allied processes — Vocabulary*:

- *Part 1: General terms [Technical Report]*
- *Part 3: Welding processes [Technical Report]*
- *Part 4: Arc welding [Technical Report]*

The following parts are under preparation:

- *Part 2: Safety and health [Technical Report]*

Friction welding is to form the subject of a future part 5.

Requests for official interpretations of any aspect of this International Standard should be directed to the Secretariat of ISO/TC 44/SC 7 via your national standards body. A complete listing of these bodies can be found at [www.iso.org](http://www.iso.org).

# Welding and allied processes — Vocabulary —

## Part 3: Welding processes

### 1 Scope

This part of ISO/TR 25901 contains terms and definitions for welding processes, classified in accordance with their physical characteristics and to the relevant energy carrier.

It does not contain terms and definitions related to specific processes or particular aspects of welding and allied processes that are covered in other parts of this Technical Report (see Foreword) or in other ISO standards.

In the main body of this part of ISO/TR 25901, terms are arranged in a systematic order. [Annex A](#) provides an index in which all terms are listed alphabetically with reference to the appropriate subclause. In addition, it provides French translations, covering two of the three official ISO languages (English, French and Russian). German translations are also provided; these are published under the responsibility of the member body for Germany (DIN) and are given for information only.

NOTE 1 Only the terms given in the official languages (English, French and Russian) are to be considered as ISO terms and definitions.

NOTE 2 All these terms and definitions are also available on the ISO Online Browsing Platform (OBP): <https://www.iso.org/obp/ui/>

### 2 Terms and definitions

For the purposes of this document, the following terms and definitions apply.

#### 2.1 Basic terms and definitions

##### 2.1.1

##### **metal welding**

operation which unifies metal(s) by means of heat or pressure, or both, in such a way that there is continuity in the nature of the metal(s) which has (have) been joined

Note 1 to entry: A filler metal, the melting temperature of which is of the same order as that of the parent metal(s), can be used and the result of welding is the weld.

Note 2 to entry: This definition also includes surfacing.

##### 2.1.2

##### **welding with pressure**

welding in which sufficient external force is applied to cause a greater or lesser degree of plastic deformation of both the faying surfaces, generally without the addition of filler metal

Note 1 to entry: Usually, but not necessarily, the faying surfaces are heated in order to permit or to facilitate unifying.

##### 2.1.3

##### **fusion welding**

welding without application of external force in which the faying surface(s) has (have) to be molten

Note 1 to entry: Usually, but not necessarily, molten filler metal is added.

#### 2.1.4

##### **energy carrier**

physical phenomenon which provides the energy required for welding either by transmission to or by transformation within the workpiece(s)

Note 1 to entry: The following energy carriers with their respective sequential numbers are used in [2.2](#):

- 1) solid body;
- 2) liquid;
- 3) gas;
- 4) electrical discharge;
- 5) radiation;
- 6) movement of a mass;
- 7) electric current;
- 8) unspecified.

Note 2 to entry: When welding using a solid body, a liquid, a gas or an electrical discharge, the heat required for welding should be applied to the workpiece(s), while when welding by means of a beam of radiant energy, movement of mass or electric current, the heat (or the mechanical energy in cold welding with pressure) is generated by energy transformation within the workpiece itself.

For a solid body, liquid and gas, the decisive factor is their enthalpy. Electrical discharge and current passage are mechanisms guiding the energy of moving charged particles to the welding zone. In the case of an electrical discharge, this is done by plasma or sparks and in the case of electric current, by resistance heat where the current is produced by induction or transmitted by conduction.

Radiation is propagation of energy in the sense of dissemination of waves by light or charged particle beams. For movement of a mass, the characteristic factors are force and displacement in time. Different kinds of movement are translational motion, rotation and oscillation.

## 2.2 Terms related to welding processes

### 2.2.1 Welding with pressure

#### 2.2.1.1 Energy carrier: solid body

##### 2.2.1.1.1

##### **heated element welding**

*welding with pressure* ([2.1.2](#)) where the workpieces are heated by the heating tool in the area where the joint will be made

Note 1 to entry: Heating can be constant or pulsating and the weld is made by the application of force without the addition of a filler material. The force is applied by either a wedge shaped tool or through a nozzle through which one of the workpieces is fed.



**2.2.1.1.2**  
**heated wedge welding**

*heated element welding* (2.2.1.1.1) by means of a heated wedge

Note 1 to entry: Heated wedge welding can also be carried out by *energy carrier* (2.1.4) movement of mass (*ultrasonic welding* (2.2.1.6.1)) or as a combination of both.

Note 2 to entry: Heated wedge welding is illustrated in [Figure 1](#).

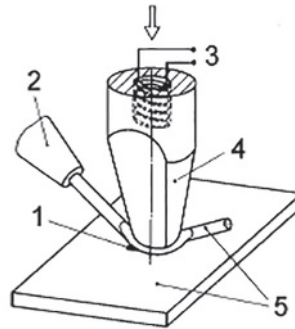

**Key**

- |   |                |   |                   |   |           |
|---|----------------|---|-------------------|---|-----------|
| 1 | weld           | 3 | power source      | 5 | workpiece |
| 2 | workpiece feed | 4 | wedge-shaped tool |   |           |

**Figure 1 — Heated wedge welding**

**2.2.1.1.3**  
**heated nozzle welding**

*heated element welding* (2.2.1.1.1) by means of a heated nozzle

Note 1 to entry: Heated nozzle welding can also be carried out by *energy carrier* (2.1.4) movement of mass (*ultrasonic welding* (2.2.1.6.1)) or as a combination of both.

Note 2 to entry: Heated nozzle welding is illustrated in [Figure 2](#).

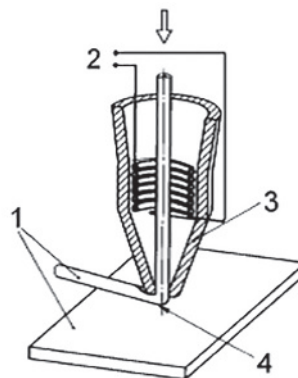

**Key**

- |   |              |   |        |
|---|--------------|---|--------|
| 1 | workpiece    | 3 | nozzle |
| 2 | power source | 4 | weld   |

**Figure 2 — Heated nozzle welding**

**2.2.1.1.4  
 nail head welding**

*heated nozzle welding* (2.2.1.1.3) in which the end of one or two wires which has been fed through the nozzle and heated by a flame or electric discharge, forms a small globule, which under the effect of the applied force is flattened into the shape of a nail head

Note 1 to entry: Nail head welding can also be carried out by *energy carrier* (2.1.4) movement of mass (*ultrasonic welding* (2.2.1.6.1)) or as a combination of both.

Note 2 to entry: Nail head welding is illustrated in [Figure 3](#).

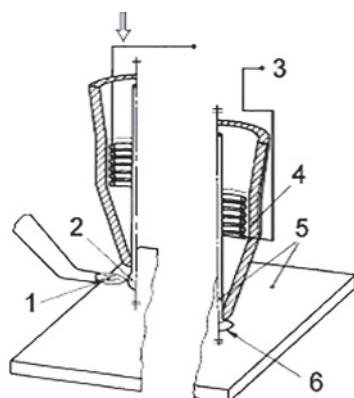

**Key**

- |   |                      |   |              |   |           |
|---|----------------------|---|--------------|---|-----------|
| 1 | flame                | 3 | power source | 5 | workpiece |
| 2 | molten metal globule | 4 | nozzle       | 6 | weld      |

**Figure 3 — Nail head welding**

**2.2.1.2 Energy carrier: liquid**

**2.2.1.2.1  
 flow welding with pressure**

*welding with pressure* (2.1.2) where the joint assembly is in a mould and molten metal is poured over the surfaces to be welded until the joint is made

Note 1 to entry: The molten metal is often produced by an aluminothermic reaction (see 2.2.2.2.2).

Note 2 to entry: Flow welding with pressure is illustrated in [Figure 4](#).

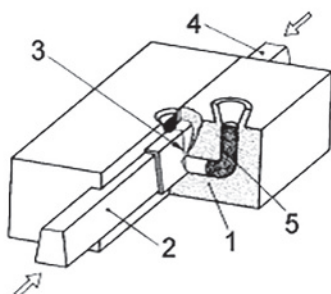

**Key**

- |   |           |   |           |   |              |
|---|-----------|---|-----------|---|--------------|
| 1 | mould     | 3 | weld      | 5 | molten metal |
| 2 | workpiece | 4 | workpiece |   |              |

**Figure 4 — Flow welding with pressure**

### 2.2.1.3 Energy carrier: gas

#### 2.2.1.3.1

##### oxyfuel gas pressure welding

*welding with pressure* (2.1.2) in which the workpieces are heated at the faying surfaces by an oxyfuel gas flame and the weld is made by applying a force without addition of filler metal

Note 1 to entry: The assembly may be of the open or closed type.

Note 2 to entry: Oxyfuel gas pressure welding is illustrated in Figure 5.

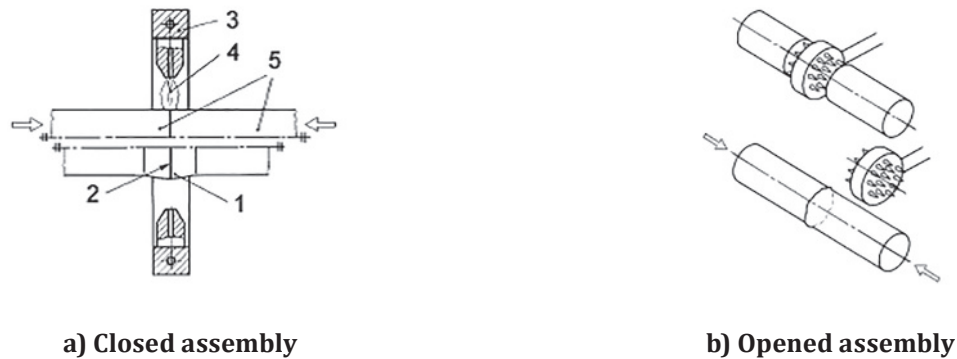

#### Key

1	upset	3	welding blowpipe	5	workpiece
2	weld	4	gas flame		

Figure 5 — Oxyfuel gas pressure welding

### 2.2.1.4 Energy carrier: electric discharge

#### 2.2.1.4.1

##### magnetically impelled arc welding

DEPRECATED: magnetically impelled arc butt welding

*arc welding* (2.2.2.4.1) with pressure in which an arc, impelled by a magnetic field, moves along the joint, heating the faying surfaces which are then brought together by a force and welded

#### 2.2.1.4.2

##### percussion welding

*welding with pressure* (2.1.2) employing the heat from an arc produced by a rapid discharge of electrical energy

Note 1 to entry: Pressure is applied percussively during or immediately following the electrical discharge. It can be accompanied by additional resistance heating.

Note 2 to entry: This process is mainly used for the welding of studs.

#### 2.2.1.4.3

##### arc stud welding

*arc welding* (2.2.2.4.1) with pressure that uses an arc between a metal stud, or similar part, and the workpiece

Note 1 to entry: Ceramic ferrule, shielding gas or both may be used.

#### 2.2.1.4.4

##### **drawn arc stud welding**

##### **drawn arc stud welding with ceramic ferrule or shielding gas**

*arc stud welding* (2.2.1.4.3) where a discharge is ignited by lifting the stud and the weld pools are shielded by a ceramic ferrule, shielding gas or both

Note 1 to entry: The welding time is usually more than 100 ms.

Note 2 to entry: Drawn arc stud welding is illustrated in [Figure 6](#).

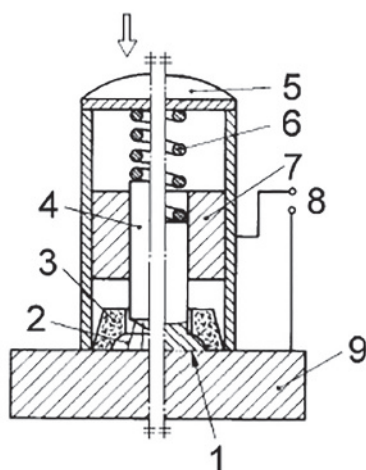

##### **Key**

1 weld	4 stud (workpiece)	7 lifting magnet
2 arc	5 welding gun	8 power source
3 ceramic ferrule	6 spring	9 workpiece

**Figure 6 — Drawn arc stud welding with ceramic ferrule**

#### 2.2.1.4.5

##### **short-cycle drawn arc stud welding**

*drawn arc stud welding* (2.2.1.4.4) where the welding time is between 10 ms and 100 ms

#### 2.2.1.4.6

##### **capacitor discharge drawn arc stud welding**

*drawn arc stud welding* (2.2.1.4.4) in which the electrical energy is provided by the discharge of a capacitor and the welding time is between 1 ms and 10 ms

Note 1 to entry: Capacitor discharge drawn arc stud welding is illustrated in [Figure 7](#).

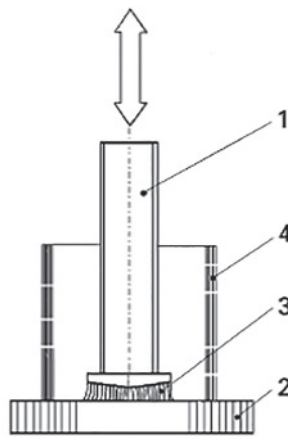

**Key**

- |             |                |
|-------------|----------------|
| 1 stud      | 3 arc          |
| 2 workpiece | 4 support tube |

**Figure 7 — Capacitor discharge drawn arc stud welding**

**2.2.1.4.7 capacitor discharge stud welding with tip ignition**

*arc stud welding* (2.2.1.4.3) where the arc is ignited by explosively melting and partially vaporizing a specially formed tip of the stud

Note 1 to entry: The workpieces are pressed together before the capacitor is totally discharged.

Note 2 to entry: Welding time is usually between 0,5 ms and 5 ms.

Note 3 to entry: Capacitor discharge stud welding with tip ignition is illustrated in [Figure 8](#).

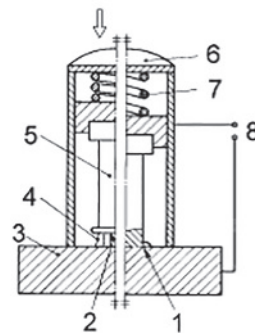

**Key**

- |             |                    |                |
|-------------|--------------------|----------------|
| 1 weld      | 4 arc              | 7 spring       |
| 2 stud tip  | 5 stud (workpiece) | 8 power source |
| 3 workpiece | 6 welding gun      |                |

**Figure 8 — Capacitor discharge stud welding with tip ignition**

**2.2.1.4.8 drawn arc stud welding with fusible collar**

*drawn arc stud welding* (2.2.1.4.4) where a discharge is ignited by lifting the stud which has a fusible collar

### 2.2.1.5 Energy carrier: radiation

(No processes known so far)

### 2.2.1.6 Energy carrier: movement of a mass

#### 2.2.1.6.1

#### ultrasonic welding

*welding with pressure* (2.1.2) in which mechanical vibrations of high frequencies and of low amplitude, superimposed on a static force, make a weld between the two workpieces to be joined at a temperature well below the melting point of the material

Note 1 to entry: Additional heat can be applied.

Note 2 to entry: Ultrasonic welding is illustrated in [Figure 9](#).

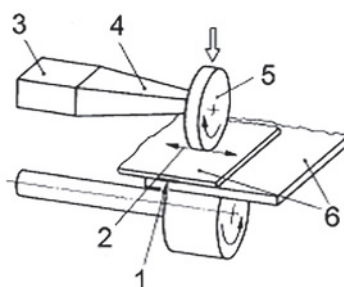

#### Key

1 weld	3 transducer	5 vibrating tool
2 ultrasonic vibration	4 sonotrode	6 workpiece

**Figure 9 — Ultrasonic welding**

#### 2.2.1.6.2

#### ultrasonic hot welding

*ultrasonic welding* (2.2.1.6.1) in which the anvil is heated separately during the welding operation

Note 1 to entry: Ultrasonic hot welding is illustrated in [Figure 10](#).

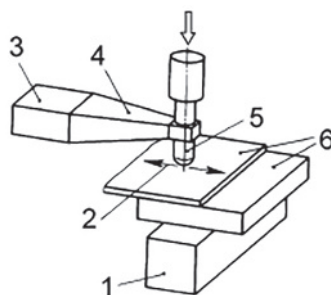

#### Key

1 electrically heated support (anvil)	3 transducer	5 vibrating tool
2 ultrasonic vibration	4 sonotrode	6 workpiece

**Figure 10 — Ultrasonic hot welding**

**2.2.1.6.3  
 friction welding**

*welding with pressure* (2.1.2) in which the interfaces are heated by friction normally by rotating one or both workpieces in contact with each other or by means of a separate rotating friction element

Note 1 to entry: The weld is completed by an upset force, generally after rotation has ceased.

Note 2 to entry: Friction welding is illustrated in [Figure 11](#).

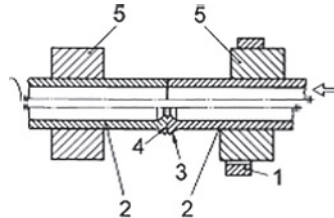

**Key**

- |   |           |   |       |   |       |
|---|-----------|---|-------|---|-------|
| 1 | brake     | 3 | flash | 5 | clamp |
| 2 | workpiece | 4 | weld  |   |       |

**Figure 11 — Friction welding**

**2.2.1.6.4  
 direct drive friction welding**

DEPRECATED: continuous drive friction welding

*friction welding* (2.2.1.6.3) using constant speed rotation

**2.2.1.6.5  
 inertia friction welding**

*friction welding* (2.2.1.6.3) where the rotational energy is stored in a fly wheel; thus the rotational speed decreases continuously

Note 1 to entry: Inertia friction welding is illustrated in [Figure 12](#).

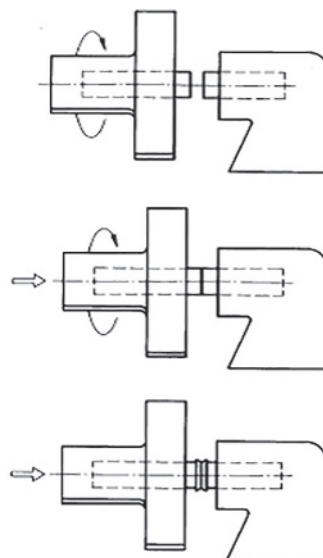

**Figure 12 — Inertia friction welding**

#### 2.2.1.6.6

##### **orbital friction welding**

*friction welding* (2.2.1.6.3) in which an orbital motion is produced at the weld interface by rotating both the workpieces at the same speed in the same direction but displacing the axis of rotation of one workpiece slightly with respect to the other

Note 1 to entry: At the end of the displaced cycle, the workpieces are aligned again and are welded.

Note 2 to entry: Orbital friction welding is illustrated in [Figure 13](#).

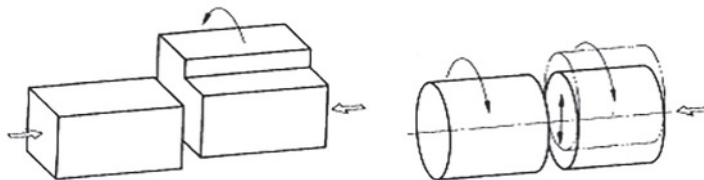

**Figure 13 — Orbital friction welding**

#### 2.2.1.6.7

##### **radial friction welding**

*friction welding* (2.2.1.6.3) in which a shaped ring is rotated and radially compressed onto two circular hollow sections in such a manner that a joint is formed

Note 1 to entry: Conventional radial friction welding is illustrated in [Figure 14 a\)](#). The technique can also be used to expand a ring inside hollow sections to form a joint; see [Figure 14 b\)](#). In a third embodiment, it is possible to weld a ring usually of a dissimilar material to the outside of a solid bar; see [Figure 14 c\)](#).

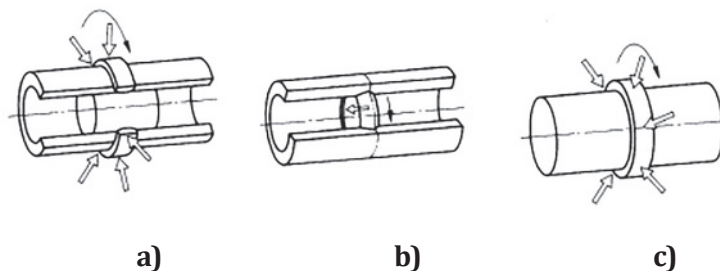

**Figure 14 — Radial friction welding**

#### 2.2.1.6.8

##### **friction stud welding**

*friction welding* (2.2.1.6.3) of studs

#### 2.2.1.6.9

##### **friction stir welding**

joining process producing a weld by the friction heating and mixing of material in the plastic state caused by a rotating tool that traverses along the weld

Note 1 to entry: Friction stir welding is illustrated in [Figure 15](#).



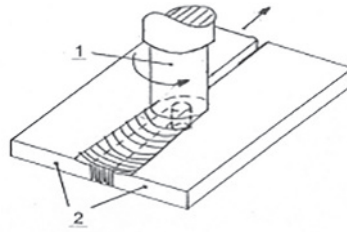

**Key**

- |   |               |   |           |
|---|---------------|---|-----------|
| 1 | rotating tool | 2 | workpiece |
|---|---------------|---|-----------|

**Figure 15 — Friction stir welding**

**2.2.1.6.10**

**shock welding**

*welding with pressure* (2.1.2) in which the workpieces are welded by the application of a striking force

Note 1 to entry: The heat generated by the sudden collision contributes to the welding.

**2.2.1.6.11**

**explosion welding**

DEPRECATED: explosive welding

*shock welding* (2.2.1.6.10) in which the workpieces are welded when impacted together by the detonation of an explosive charge

Note 1 to entry: Explosion welding is illustrated in [Figure 16](#).

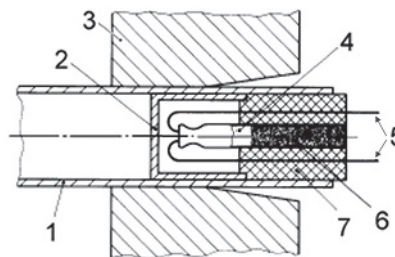

**Key**

- |   |                   |   |                  |   |                             |
|---|-------------------|---|------------------|---|-----------------------------|
| 1 | tube              | 4 | detonator        | 6 | main explosive charge       |
| 2 | protective sheath | 5 | detonation wires | 7 | plastic transmission medium |
| 3 | tube plate        |   |                  |   |                             |

**Figure 16 — Explosion welding of tube to plate**

**2.2.1.6.12**

**magnetic pulse welding**

DEPRECATED: magnetic impulse welding

*shock welding* (2.2.1.6.10) in which a high current impulse passing through a coil surrounding the workpieces produces a magnetic field which exerts the welding force

Note 1 to entry: Magnetic pulse welding is illustrated in [Figure 17](#).

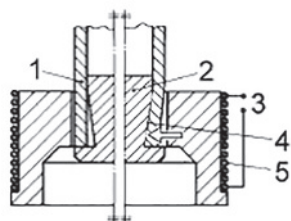

**Key**

- |                    |                |                 |
|--------------------|----------------|-----------------|
| 1 tube (workpiece) | 3 power source | 5 magnetic coil |
| 2 plug (workpiece) | 4 weld         |                 |

**Figure 17 — Magnetic pulse welding**

**2.2.1.6.13**

**forge welding**

*welding with pressure* (2.1.2) in which the workpieces are heated in air in a forge and the weld is made by applying blows or some other impulsive force sufficient to cause permanent deformation at the interfaces

Note 1 to entry: Forge welding is illustrated in [Figure 18](#).

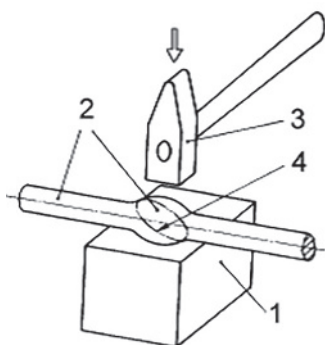

**Key**

- |             |          |
|-------------|----------|
| 1 anvil     | 3 hammer |
| 2 workpiece | 4 weld   |

**Figure 18 — Forge welding**

**2.2.1.6.14**

**cold pressure welding**

*welding with pressure* (2.1.2) in which continuous pressure alone is used, producing considerable plastic deformation

**2.2.1.6.15**

**cold upset welding**

*cold pressure welding* (2.2.1.6.14) in which dies are used as jaws to provide the required deformation and flow

Note 1 to entry: Cold upset welding is illustrated in [Figure 19](#).

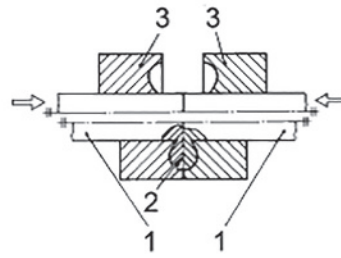

**Key**

- |             |        |          |
|-------------|--------|----------|
| 1 workpiece | 2 weld | 3 clamps |
|-------------|--------|----------|

**Figure 19 — Cold upset welding**

**2.2.1.6.16**

**cold pressure extrusion welding**

*cold pressure welding (2.2.1.6.14) using a special extrusion die*

Note 1 to entry: Cold pressure extrusion welding is illustrated in [Figure 20](#).

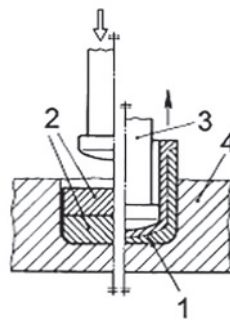

**Key**

- |             |           |
|-------------|-----------|
| 1 weld      | 3 plunger |
| 2 workpiece | 4 die     |

**Figure 20 — Cold pressure extrusion welding**

**2.2.1.7 Energy carrier: electric current**

**2.2.1.7.1**

**resistance welding**

*welding with pressure (2.1.2) in which the heat necessary for welding is produced by resistance to an electrical current flowing through the welding zone*

**2.2.1.7.2**

**resistance spot welding**

*resistance welding (2.2.1.7.1) in which the weld is produced at a spot in the workpieces between spot welding electrodes, the weld being of approximately the same area as the electrode tips*

Note 1 to entry: During the process, force is applied to the spot by the electrodes.

Note 2 to entry: Resistance spot welding is illustrated in [Figure 21](#).

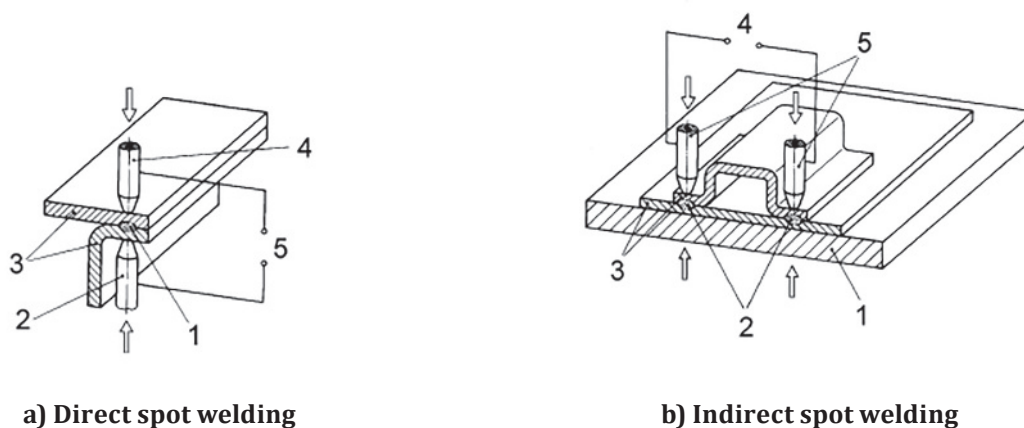

a) Direct spot welding

b) Indirect spot welding

**Key**

- |   |                        |   |                        |
|---|------------------------|---|------------------------|
| 1 | weld spot              | 1 | conductive base plate  |
| 2 | spot-welding electrode | 2 | weld spot              |
| 3 | workpiece              | 3 | workpiece              |
| 4 | spot-welding electrode | 4 | power source           |
| 5 | power source           | 5 | spot-welding electrode |

**Figure 21 — Resistance spot welding**

**2.2.1.7.3**

**resistance seam welding**

*resistance welding* (2.2.1.7.1) in which force is applied continuously and current continuously or intermittently to produce a linear weld, the workpieces being placed between two electrode wheels or an electrode wheel and an electrode bar

Note 1 to entry: The wheels apply the force and current and rotate continuously during the making of the seam weld.

**2.2.1.7.4**

**lap seam welding**

*resistance seam welding* (2.2.1.7.3) to produce an overlap joint

Note 1 to entry: Lap seam welding is illustrated in [Figure 22](#).

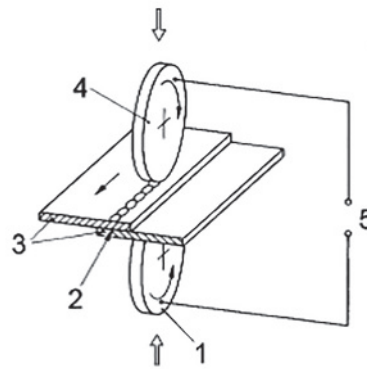

**Key**

- |                   |                   |                |
|-------------------|-------------------|----------------|
| 1 electrode wheel | 3 workpiece       | 5 power source |
| 2 weld            | 4 electrode wheel |                |

**Figure 22 — Lap seam welding**

**2.2.1.7.5**

**mash seam welding**

*resistance seam welding* (2.2.1.7.3) of two workpieces of similar thickness, where the overlap determines the width of the weld so that the ultimate thickness of the workpiece at the weld approximates to that of one component

Note 1 to entry: Mash seam welding is illustrated in [Figure 23](#).



**a) Before welding**

**b) After welding**

**Key**

- |              |        |
|--------------|--------|
| 1 workpieces | 2 weld |
|--------------|--------|

**Figure 23 — Mash seam welding**

**2.2.1.7.6**

**prep-lap seam welding**

*lap seam welding* (2.2.1.7.4) with prior preparation of the sheet edges

Note 1 to entry: Prep-lap seam welding is illustrated in [Figure 24](#).



Figure 24 — Prep-lap seam welding

2.2.1.7.7

**wire seam welding**

*resistance seam welding* (2.2.1.7.3) of two overlapped coated components with copper or copper alloy wires between the electrode wheels and the surfaces of the components

2.2.1.7.8

**foil butt-seam welding**

*resistance seam welding* (2.2.1.7.3) of two close square butted workpieces with metal tape placed or fed centrally to bridge both sides of the joint

Note 1 to entry: Foil butt seam-welding is illustrated in [Figure 25](#).

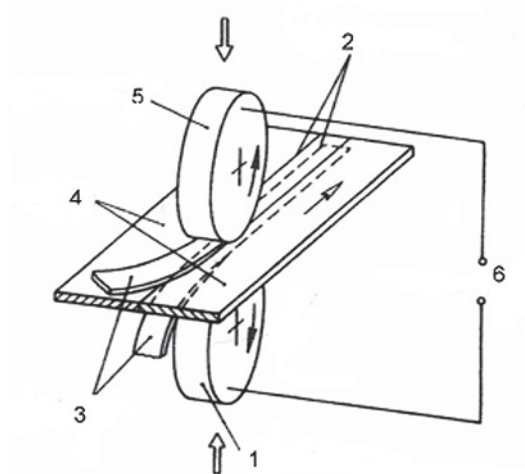

**Key**

- |                   |                 |                   |
|-------------------|-----------------|-------------------|
| 1 electrode wheel | 3 contact strip | 5 electrode wheel |
| 2 weld            | 4 workpiece     | 6 power source    |

Figure 25 — Foil butt-seam welding

2.2.1.7.9

**seam welding with strip**

*lap seam welding* (2.2.1.7.4) using a contact strip on one side or both sides of the lapping workpieces

Note 1 to entry: Seam welding with strip is illustrated in [Figure 26](#).

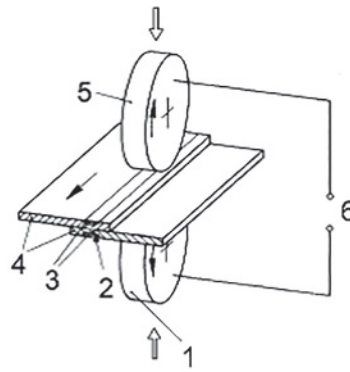

**Key**

- |                   |                 |                   |
|-------------------|-----------------|-------------------|
| 1 electrode wheel | 3 contact strip | 5 electrode wheel |
| 2 weld            | 4 workpiece     | 6 power source    |

**Figure 26 — Seam welding with strip**

**2.2.1.7.10**

**projection welding**

*resistance welding* (2.2.1.7.1) in which the force and current are localized by the use of a projection or projections raised on or formed from one or more of the faying surfaces, the projections collapsing during welding

Note 1 to entry: Current and force are usually transmitted through platens, fixtures, jigs or clamps.

Note 2 to entry: Projection welding is illustrated in [Figures 27](#) and [28](#).

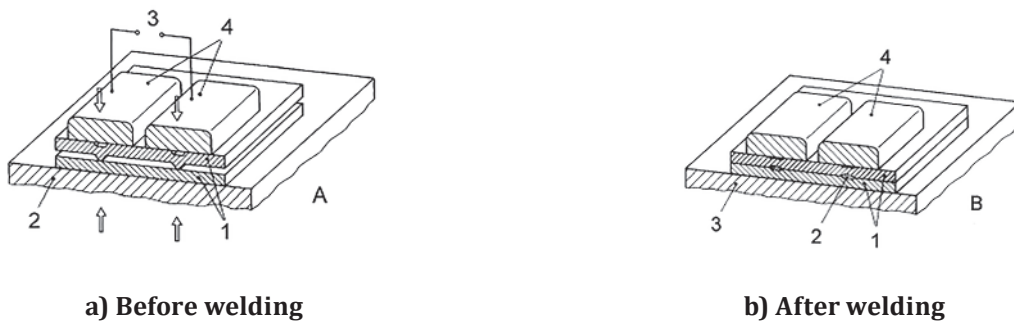

**Key**

- |                                |                                |
|--------------------------------|--------------------------------|
| A before welding               | B after welding                |
| 1 workpiece                    | 1 workpiece                    |
| 2 base plate                   | 2 weld                         |
| 3 power source                 | 3 base plate                   |
| 4 projection welding electrode | 4 projection welding electrode |

**Figure 27 — Indirect projection welding**

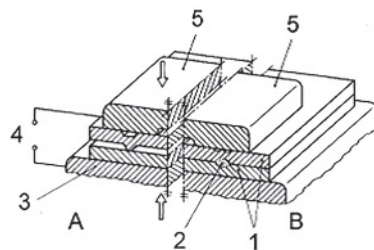

**Key**

A	before welding	2	weld	4	power source
B	after welding	3	electrode	5	projection welding electrode
1	workpiece				

**Figure 28 — Direct projection welding**

**2.2.1.7.11**

**flash welding**

*resistance welding* (2.2.1.7.1) during which heating is obtained when the workpieces are progressively and repeatedly advanced towards each other, causing the current to flow through localized points, thus creating flashing and expulsion of molten metal

Note 1 to entry: When the welding temperature is reached, the rapid application of force produces upset metal and completes the weld. Flashing can be preceded with preheating (241) or without (242). Current and force are transmitted by clamps.

Note 2 to entry: Flash welding is illustrated in [Figure 29](#).

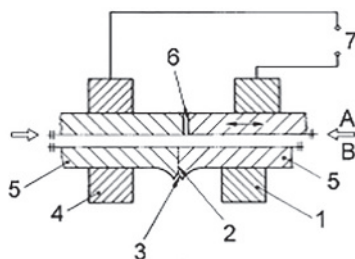

**Key**

A	before welding	2	weld	5	workpiece
B	after welding	3	flash	6	flashing area
1	clamp	4	clamp	7	power source

**Figure 29 — Flash welding**



**2.2.1.7.12**  
**resistance butt welding**

*resistance welding* (2.2.1.7.1) in which the components are butted together under pressure before heating is started

Note 1 to entry: Pressure is maintained and current is allowed to flow until the welding temperature is reached at which point upset metal is produced.

Note 2 to entry: Current and force are transmitted through clamps.

Note 3 to entry: Resistance butt welding is illustrated in [Figure 30](#).

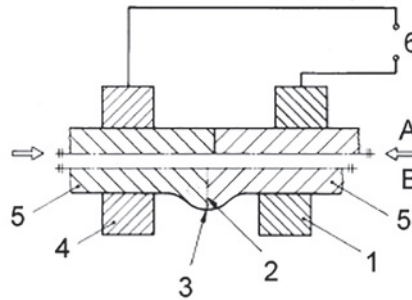

**Key**

A	before welding	2	weld	5	workpiece
B	after welding	3	upset	6	power source
1	clamp	4	clamp		

**Figure 30 — Resistance butt welding**

**2.2.1.7.13**  
**resistance stud welding**

*stud welding using projection welding* (2.2.1.7.10)

Note 1 to entry: Resistance stud welding is illustrated in [Figure 31](#).

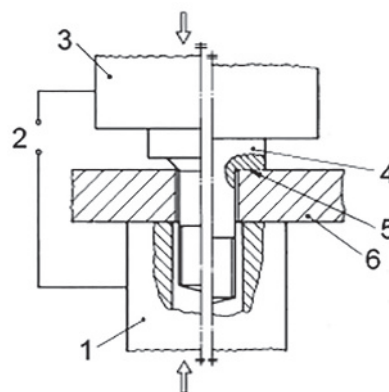

**Key**

1	projection welding electrode	3	projection welding electrode	5	weld
2	power source	4	stud (workpiece)	6	workpiece

**Figure 31 — Resistance stud welding**

#### 2.2.1.7.14

##### HF resistance welding

##### high frequency resistance welding

*resistance welding* (2.2.1.7.1) in which alternating current of at least 10 kHz is fed through mechanical contacts or induced by an inductor in the workpiece

Note 1 to entry: The high frequency current is concentrated along adjacent surfaces to produce highly localized heat prior to the application of welding force.

Note 2 to entry: HF resistance welding is illustrated in [Figure 32](#).

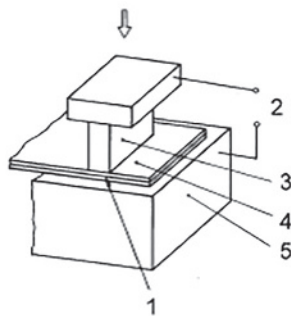

##### Key

- |   |                             |   |           |   |           |
|---|-----------------------------|---|-----------|---|-----------|
| 1 | weld                        | 3 | electrode | 5 | electrode |
| 2 | high-frequency power source | 4 | workpiece |   |           |

**Figure 32 — HF resistance welding**

#### 2.2.1.7.15

##### induction welding

*welding with pressure* (2.1.2) in which the heat is obtained from the resistance of the workpieces to induced electric current

#### 2.2.1.7.16

##### induction butt welding

*induction welding* (2.2.1.7.15) in which the components are butted together under pressure before or after heating is started

Note 1 to entry: When the welding temperature is reached, upset force is applied to produce a forge weld.

#### 2.2.1.7.17

##### induction seam welding

*induction welding* (2.2.1.7.15) in which the force is applied by one or more forging wheel(s) to produce a linear forge weld

Note 1 to entry: It is generally used with a set of forging wheels to produce tubular components from strips, sheets or plates.

Note 2 to entry: Induction seam welding is illustrated in [Figure 33](#).

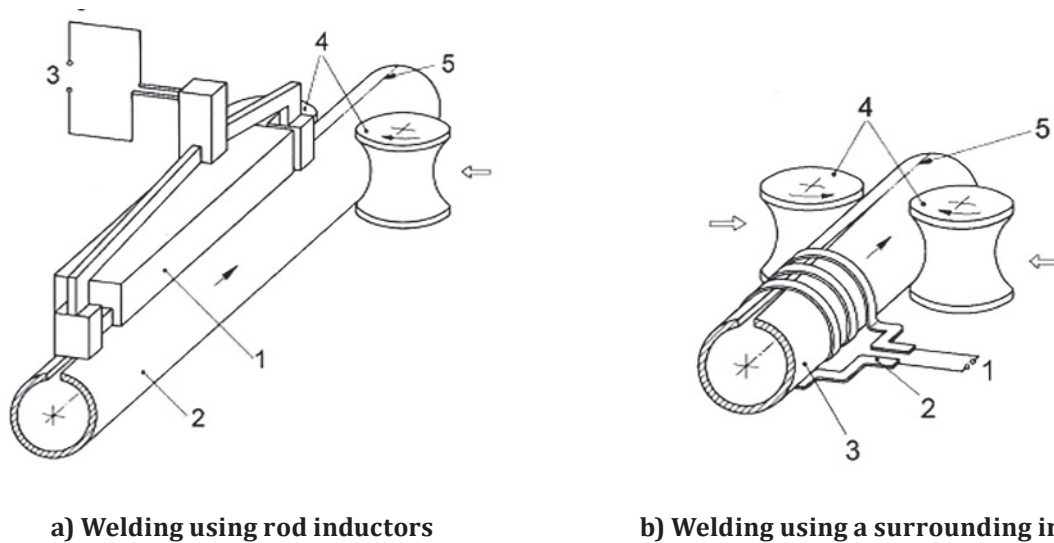

**Key**

- |   |                 |   |                 |
|---|-----------------|---|-----------------|
| 1 | inductor        | 1 | power source    |
| 2 | workpiece       | 2 | induction coil  |
| 3 | power source    | 3 | workpiece       |
| 4 | pressure roller | 4 | pressure roller |
| 5 | weld            | 5 | weld            |

**Figure 33 — Induction seam welding**

**2.2.1.7.18**

**HF induction welding**

**high frequency induction welding**

*induction welding* (2.2.1.7.15) in which alternating current of high frequency is fed through mechanical contacts or induced by an inductor in the workpiece

**2.2.1.8 Energy carrier: unspecified**

**2.2.1.8.1**

**diffusion welding**

*welding with pressure* (2.1.2) whereby the workpieces are kept in contact under specified continual pressure and are heated either on their faying surfaces, or in their entirety at a defined temperature over a controlled time

Note 1 to entry: This results in local plastic deformation and thereby intimate contact of the surfaces and diffusion of the atoms through the interface. This produces complete continuity of the material. The operation can take place in a vacuum, under a gas shield or in a fluid, preferably without the addition of a filler metal.

Note 2 to entry: Diffusion welding is illustrated in [Figure 34](#).

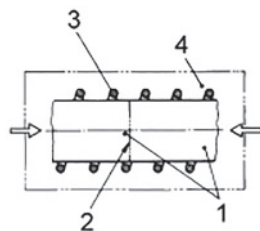

**Key**

- |   |           |   |                   |
|---|-----------|---|-------------------|
| 1 | workpiece | 3 | induction heating |
| 2 | weld      | 4 | work chamber      |

**Figure 34 — Diffusion welding**

**2.2.1.8.2**

**hot pressure welding**

*welding with pressure* (2.1.2) where sufficient heat and pressure are applied to produce significant deformation of the workpieces

**2.2.1.8.3**

**roll welding**

*hot pressure welding* (2.2.1.8.2) in which a force is progressively applied by mechanically operated rolls after heating

Note 1 to entry: Roll welding is illustrated in [Figure 35](#).

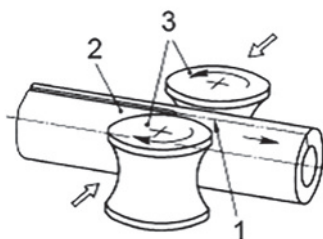

**Key**

- |   |      |   |           |   |      |
|---|------|---|-----------|---|------|
| 1 | weld | 2 | workpiece | 3 | roll |
|---|------|---|-----------|---|------|

**Figure 35 — Roll welding**

**2.2.2 Fusion welding**

**2.2.2.1 Energy carrier: solid body**

(No processes known so far)

**2.2.2.2 Energy carrier: liquid**

**2.2.2.2.1**

**flow welding**

*fusion welding* (2.1.3) where the weld assembly is enclosed in a mould and molten filler metal is poured over the surfaces to be welded until the weld is made

Note 1 to entry: Flow welding is illustrated in [Figure 36](#).

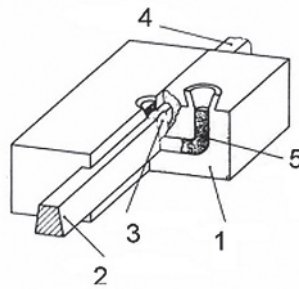

**Key**

- |             |             |                |
|-------------|-------------|----------------|
| 1 mould     | 3 weld      | 5 molten metal |
| 2 workpiece | 4 workpiece |                |

**Figure 36 — Flow welding**

**2.2.2.2.2**

**aluminothermic welding**

*flow welding* (2.2.2.2.1) whereby the welding heat is obtained from reacting a mixture of metal oxides with finely ground aluminium powder whose ignition produces an exothermic reaction in which the molten metal produced is the filler metal

Note 1 to entry: Preheating can be employed. In certain variants of the process, additional pressure is also applied.

Note 2 to entry: Aluminothermic welding is illustrated in [Figure 37](#).

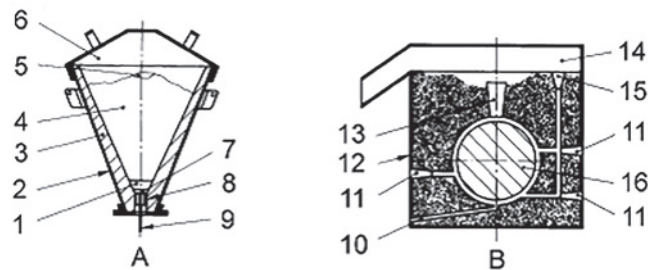

**Key**

- |                         |                      |                    |
|-------------------------|----------------------|--------------------|
| A crucible              | 5 ignition powder    | 11 preheating gate |
| B section through mould | 6 crucible cap       | 12 mould box       |
| 1 slag seal             | 7 thermal insulation | 13 riser           |
| 2 crucible shell        | 8 thimble            | 14 slag trough     |
| 3 refractory lining     | 9 tapping pin        | 15 pouring gate    |
| 4 charge                | 10 wax drain         | 16 workpiece       |

**Figure 37 — Aluminothermic welding**

**2.2.2.3 Energy carrier: gas**

**2.2.2.3.1**  
**gas welding**

*fusion welding* (2.1.3) in which the heat for welding is produced by the combustion of a fuel gas, or a mixture of fuel gases, with an admixture of oxygen

Note 1 to entry: Gas welding is illustrated in [Figure 38](#).

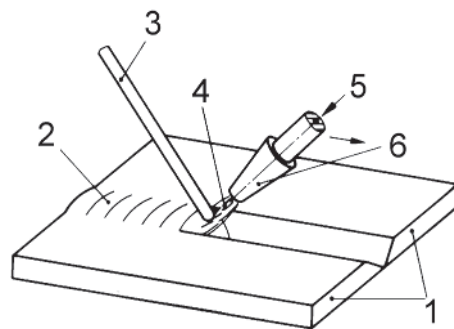

**Key**

- |             |                |                       |
|-------------|----------------|-----------------------|
| 1 workpiece | 3 filler metal | 5 fuel gas and oxygen |
| 2 weld      | 4 gas flame    | 6 welding blowpipe    |

**Figure 38 — Gas welding**

**2.2.2.3.2**  
**oxyacetylene welding**

*gas welding* (2.2.2.3.1) where the fuel gas is acetylene

**2.2.2.3.3**  
**oxypropane welding**

*gas welding* (2.2.2.3.1) where the fuel gas is propane

**2.2.2.3.4**  
**oxyhydrogen welding**

*gas welding* (2.2.2.3.1) where the fuel gas is hydrogen

**2.2.2.4 Energy carrier: electric discharge**

**2.2.2.4.1**  
**arc welding**

*fusion welding* (2.1.3) using an electric arc

**2.2.2.4.2**  
**metal arc welding**

*arc welding* (2.2.2.4.1) using a consumable electrode

**2.2.2.4.3**  
**metal arc welding without gas protection**

*metal arc welding* (2.2.2.4.2) in which no external shielding gas is used

**2.2.2.4.4**  
**manual metal arc welding**

manually operated *metal arc welding* (2.2.2.4.2) using a covered electrode

Note 1 to entry: Manual metal arc welding is illustrated in [Figure 39](#).

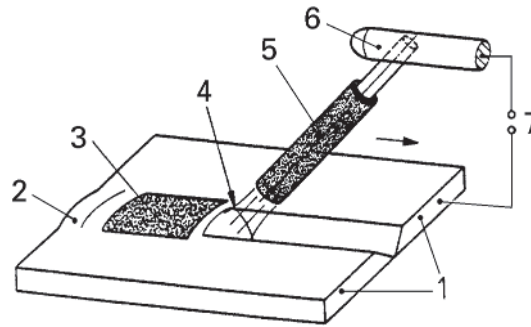

**Key**

- |             |                     |                    |
|-------------|---------------------|--------------------|
| 1 workpiece | 4 arc               | 6 electrode holder |
| 2 weld      | 5 covered electrode | 7 power source     |
| 3 slag      |                     |                    |

**Figure 39 — Manual metal arc welding**

**2.2.2.4.5**

**gravity welding**

**gravity (arc) welding with covered electrode**

*metal arc welding (2.2.2.4.2)* using a covered electrode supported by a mechanism which allows the electrode to slide down and move along the joint under gravity

Note 1 to entry: Gravity welding is illustrated in [Figure 40](#).

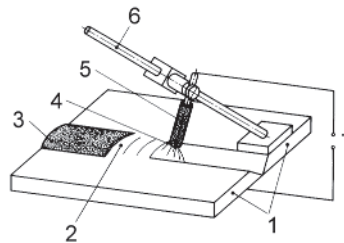

**Key**

- |             |                     |                |
|-------------|---------------------|----------------|
| 1 workpiece | 4 arc               | 6 bar          |
| 2 weld      | 5 covered electrode | 7 power source |
| 3 slag      |                     |                |

**Figure 40 — Gravity welding**

**2.2.2.4.6**

**self-shielded tubular cored arc welding**

*metal arc welding (2.2.2.4.2)* using a tubular cored electrode without external shielding gas

Note 1 to entry: Self-shielded tubular cored arc welding is illustrated in [Figure 41](#).

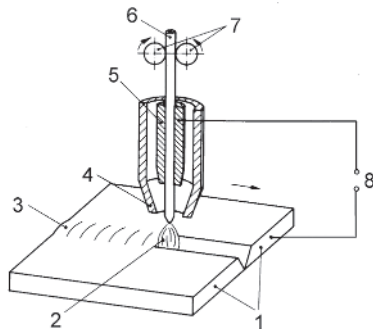

**Key**

- |             |                        |                   |
|-------------|------------------------|-------------------|
| 1 workpiece | 4 torch                | 7 wire feed rolls |
| 2 arc       | 5 contact tip          | 8 power source    |
| 3 weld      | 6 flux-cored electrode |                   |

**Figure 41 — Self-shielded tubular cored arc welding**

**2.2.2.4.7**

**submerged arc welding**

*metal arc welding* (2.2.2.4.2) in which one or more wire electrode(s) or strip electrode(s) are used, the arc(s) being completely enveloped by molten slag which fuses from the granular flux that is deposited loosely in the joint

Note 1 to entry: Submerged arc welding is illustrated in [Figure 42](#).

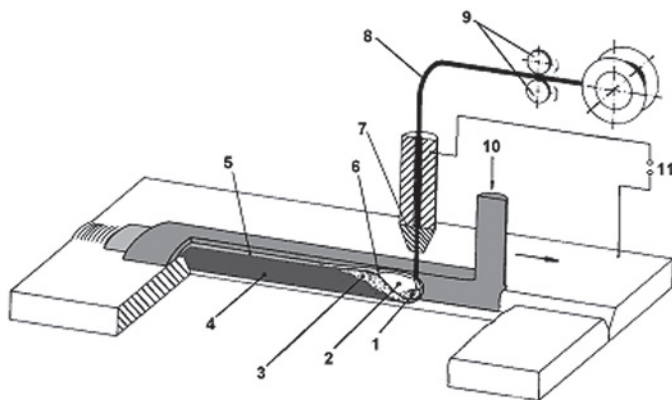

**Key**

- |             |                   |                   |
|-------------|-------------------|-------------------|
| 1 arc       | 5 solidified slag | 9 wire feed rolls |
| 2 cavity    | 6 liquefied slag  | 10 flux           |
| 3 weld pool | 7 contact tube    | 11 power source   |
| 4 weld      | 8 wire electrode  |                   |

**Figure 42 — Submerged arc welding**

**2.2.2.4.8**

**submerged arc welding with solid wire electrode**

*submerged arc welding* (2.2.2.4.7) using a solid wire electrode



**2.2.2.4.9**

**submerged arc welding with strip electrode**

*submerged arc welding* ([2.2.2.4.7](#)) using a solid or cored strip electrode

**2.2.2.4.10**

**submerged arc welding with metal powder addition**

*submerged arc welding* ([2.2.2.4.7](#)) using one or more wire electrodes with the addition of metal powder

**2.2.2.4.11**

**submerged arc welding with tubular cored electrode**

*submerged arc welding* ([2.2.2.4.7](#)) using one or more tubular electrodes

**2.2.2.4.12**

**submerged arc welding with cored strip electrode**

*submerged arc welding* ([2.2.2.4.7](#)) using a cored strip electrode

**2.2.2.4.13**

**gas-shielded metal arc welding**

**gas metal arc welding**

**MIG/MAG welding**

*metal arc welding* ([2.2.2.4.2](#)) using a wire electrode in which the arc and the weld pool are shielded from the atmosphere by a shroud of gas supplied from an external source

Note 1 to entry: Acronyms MIG and MAG, respectively, stand for metal inert gas and metal active gas.

Note 2 to entry: Gas-shielded metal arc welding is illustrated in [Figure 43](#).

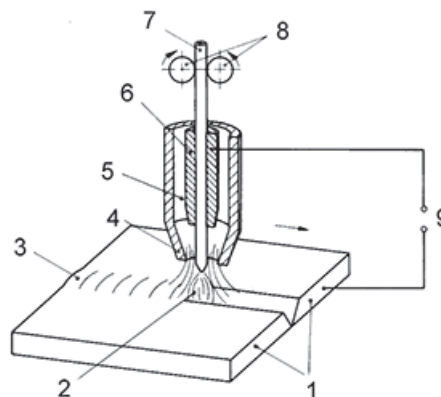

**Key**

1	workpiece	4	nozzle	7	wire electrode
2	arc	5	shielding gas	8	wire feed rolls
3	weld	6	contact tip	9	power source

**Figure 43 — Gas-shielded metal arc welding**

**2.2.2.4.14**

**MIG welding with solid wire electrode**

*gas-shielded metal arc welding* ([2.2.2.4.13](#)) using a solid wire electrode and the shielding is provided by an inert gas

Note 1 to entry: Acronym MIG stands for metal inert gas. The shielding gas used typically consists of argon, helium or a mixture of both.

#### 2.2.2.4.15

##### **MIG welding with flux cored wire electrode**

*gas-shielded metal arc welding* ([2.2.2.4.13](#)) using a flux cored wire electrode and the shielding is provided by an inert gas

Note 1 to entry: Acronym MIG stands for metal inert gas. The shielding gas used typically consists of argon, helium or a mixture of both.

#### 2.2.2.4.16

##### **MIG welding with metal cored wire electrode**

*gas-shielded metal arc welding* ([2.2.2.4.13](#)) using a metal cored wire electrode and the shielding is provided by an inert gas

Note 1 to entry: Acronym MIG stands for metal inert gas. The shielding gas used typically consists of argon, helium or a mixture of both.

#### 2.2.2.4.17

##### **MAG welding with solid wire electrode**

*gas-shielded metal arc welding* ([2.2.2.4.13](#)) using a solid wire electrode and the shielding is provided by a chemically active gas

Note 1 to entry: Acronym MAG stands for metal active gas. The shielding gas used typically consists of a mixture containing 0,5 % or more of oxygen or carbon dioxide.

#### 2.2.2.4.18

##### **MAG welding with flux cored electrode**

*gas-shielded metal arc welding* ([2.2.2.4.13](#)) using a flux cored wire electrode and the shielding is provided by a chemically active gas

Note 1 to entry: Acronym MAG stands for metal active gas. The shielding gas used typically consists of a mixture containing 0,5 % or more of oxygen or carbon dioxide.

#### 2.2.2.4.19

##### **MAG welding with metal cored electrode**

*gas-shielded metal arc welding* ([2.2.2.4.13](#)) using a metal cored wire electrode and the shielding is provided by a chemically active gas

Note 1 to entry: Acronym MAG stands for metal active gas. The shielding gas used typically consists of a mixture containing 0,5 % or more of oxygen or carbon dioxide.

#### 2.2.2.4.20

##### **electrogas welding**

*gas-shielded metal arc welding* ([2.2.2.4.13](#)) using a wire or strip electrode to deposit metal into the weld pool, which is retained in the joint by cooled shoes which move progressively upwards as the weld is made

Note 1 to entry: Electrogas welding is illustrated in [Figure 44](#).

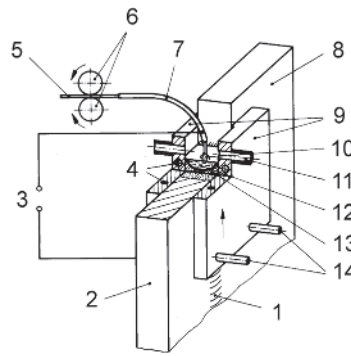

**Key**

1 weld	6 wire feed rolls or strip feed rolls	11 shielding gas
2 workpiece	7 electrode guide	12 weld pool
3 power source	8 workpiece	13 weld metal
4 water cooling	9 sliding shoes	14 water cooling
5 wire electrode or strip electrode	10 arc	

**Figure 44 — Electrogas welding**

**2.2.2.4.21**

**gas-shielded arc welding with non-consumable tungsten electrode  
gas tungsten arc welding**

gas-shielded *arc welding* (2.2.2.4.1) using a non-consumable, pure or activated tungsten electrode in which the arc and the weld pool are protected by a shielding gas

**2.2.2.4.22**

**TIG welding with solid filler material (wire/rod)**

gas-shielded *arc welding with non-consumable tungsten electrode* (2.2.2.4.21) with a solid wire or rod and an inert shielding gas

Note 1 to entry: Acronym TIG stands for tungsten inert gas. The shielding gas used typically consists of argon, helium or a mixture of both.

Note 2 to entry: TIG welding with solid filler material is illustrated in [Figure 45](#).

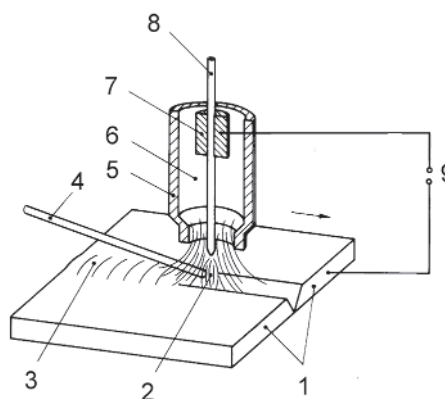

**Key**

1 workpiece	4 filler metal	7 collet
2 arc	5 nozzle	8 tungsten electrode
3 weld	6 shielding gas	9 power source

**Figure 45 — Tungsten inert gas welding**

#### 2.2.2.4.23

##### **autogenous TIG welding**

*gas-shielded arc welding with non-consumable tungsten electrode* ([2.2.2.4.21](#)) without filler material

Note 1 to entry: Acronym TIG stands for tungsten inert gas. The shielding gas used typically consists of argon, helium or a mixture of both.

#### 2.2.2.4.24

##### **TIG welding with tubular cored filler material (wire/rod)**

*gas-shielded arc welding with non-consumable tungsten electrode* ([2.2.2.4.21](#)) using a tubular cored wire or rod and an inert shielding gas

Note 1 to entry: Acronym TIG stands for tungsten inert gas. The shielding gas used typically consists of argon, helium or a mixture of both.

#### 2.2.2.4.25

##### **TIG welding using reducing gas and solid filler material (wire/rod)**

*gas-shielded arc welding with non-consumable tungsten electrode* ([2.2.2.4.21](#)) using a solid wire or rod and a reducing shielding gas

Note 1 to entry: Acronym TIG stands for tungsten inert gas. The shielding gas used typically consists of a mixture containing 0,5 % to 50 % of hydrogen.

#### 2.2.2.4.26

##### **TIG welding using reducing gas and tubular cored filler material (wire/rod)**

*gas-shielded arc welding with non-consumable tungsten electrode* ([2.2.2.4.21](#)) using a tubular cored wire or rod and a reducing shielding gas

Note 1 to entry: Acronym TIG stands for tungsten inert gas. The shielding gas used typically consists of a mixture containing 0,5 % to 50 % of hydrogen.

#### 2.2.2.4.27

##### **gas-shielded arc welding with non-consumable tungsten electrode using active gas**

##### **TAG welding**

*gas-shielded arc welding with non-consumable tungsten electrode* ([2.2.2.4.21](#)) in which the arc and the weld pool are protected by an active shielding gas

Note 1 to entry: Acronym TAG stands for tungsten active gas. The shielding gas used typically consists of a mixture containing 0,5 % or more of oxygen or carbon dioxide.

#### 2.2.2.4.28

##### **plasma arc welding**

*arc welding* ([2.2.2.4.1](#)) using the plasma of a constricted arc

Note 1 to entry: Shielding can be supplemented by an auxiliary gas. Filler metal can be added.

#### 2.2.2.4.29

##### **plasma MIG welding**

combination of *MIG welding* ([2.2.2.4.14](#)) and *plasma arc welding* ([2.2.2.4.28](#))

Note 1 to entry: This is a hybrid welding process. If the MIG welding is done with a solid wire electrode, the process number should read 15 + 131.

Note 2 to entry: Acronym MIG stands for metal inert gas. The shielding gas used typically consists of argon, helium or a mixture of both.

Note 3 to entry: Plasma MIG welding is illustrated in [Figure 46](#).

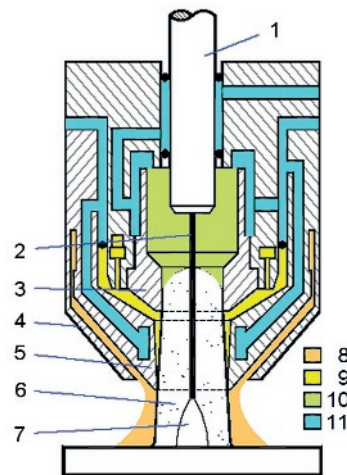

**Key**

1 collet	5 plasma gas nozzle	9 plasma gas
2 wire electrode (MIG)	6 plasma arc	10 shielding gas (MIG)
3 plasma electrode	7 welding arc (MIG)	11 water cooling
4 shielding gas nozzle	8 shielding gas	

**Figure 46 — Plasma MIG welding**

**2.2.2.4.30**

**powder plasma arc welding**

*plasma-arc welding with transferred arc* ([2.2.2.4.31](#)) and metallic powder feeding

Note 1 to entry: Powder plasma arc welding is illustrated in [Figure 47](#).

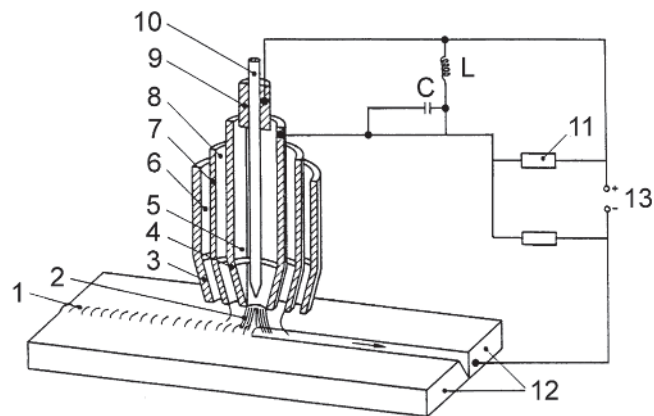

**Key**

1 weld	6 extra shielding gas (optional)	10 tungsten electrode
2 transferred arc	7 shielding gas nozzle	11 ignition device
3 extra shielding gas nozzle (optional)	8 filler powder + shielding gas	12 workpiece
4 plasma gas nozzle	9 collet	13 power source
5 plasma gas		

**Figure 47 — Powder plasma welding**

### 2.2.2.4.31

#### plasma arc welding with transferred arc

*plasma arc welding* (2.2.2.4.28) in which the electrical power supply is connected between electrode and workpiece

Note 1 to entry: Plasma arc welding with transferred arc is illustrated in [Figure 48](#).

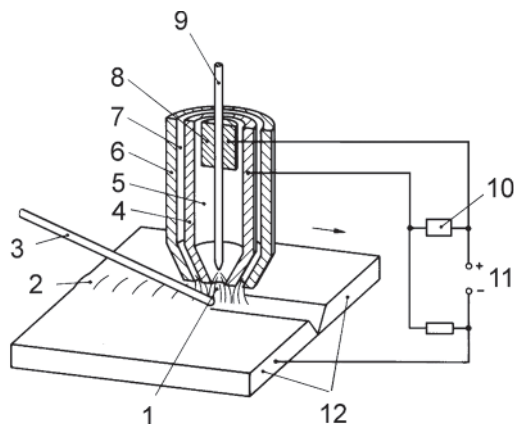

#### Key

1 transferred arc	5 plasma gas	9 tungsten electrode
2 weld	6 shielding gas nozzle	10 ignition device
3 filler metal	7 shielded gas nozzle	11 power source
4 plasma gas nozzle	8 collet	12 workpiece

Figure 48 — Plasma arc welding with transferred arc

### 2.2.2.4.32

#### plasma arc welding with non-transferred arc

#### plasma jet welding

*plasma arc welding* (2.2.2.4.28) in which the electrical power supply is connected between the collet and the plasma gas nozzle thus producing a plasma jet

Note 1 to entry: Plasma arc welding with non-transferred arc is illustrated in [Figure 49](#).

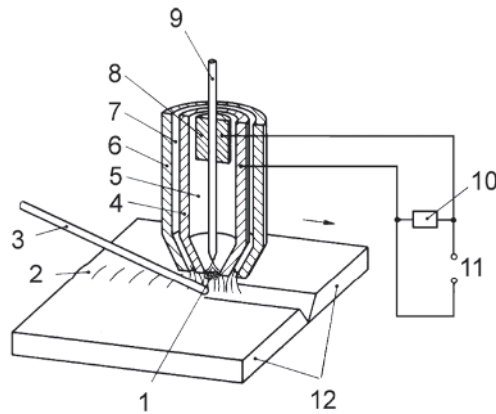

**Key**

1 non-transferred arc	5 plasma gas	9 tungsten electrode
2 weld	6 shielding gas nozzle	10 ignition device
3 filler metal	7 shielding gas	11 power source
4 plasma gas nozzle	8 collet	12 workpiece

**Figure 49 — Plasma arc welding with non-transferred arc**

**2.2.2.4.33**

**plasma arc welding with partially transferred arc**

*plasma arc welding* (2.2.2.4.28) where the arc switches between transferred and non-transferred modes

Note 1 to entry: Plasma arc welding with partially transferred arc is usually used for surfacing.

Note 2 to entry: Plasma arc welding with partially transferred arc is illustrated in [Figure 50](#).

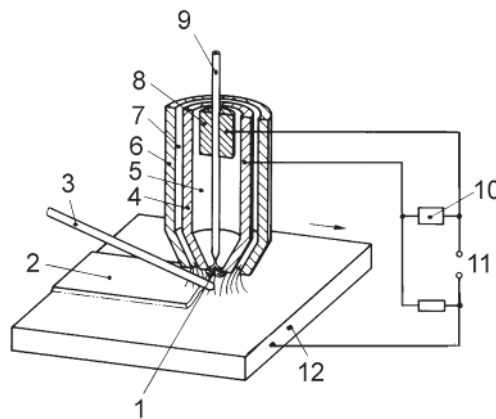

**Key**

1 semi-transferred arc	5 plasma gas	9 tungsten electrode
2 build-up welding	6 shielding gas nozzle	10 ignition device
3 filler metal	7 shielding gas	11 power source
4 plasma gas nozzle	8 collet	12 workpiece

**Figure 50 — Plasma arc welding with partially transferred arc**

### 2.2.2.5 Energy carrier: radiation

#### 2.2.2.5.1

#### **electron beam welding**

*fusion welding* (2.1.3) using a focused beam of electrons

Note 1 to entry: Electron beam welding is illustrated in [Figure 51](#).

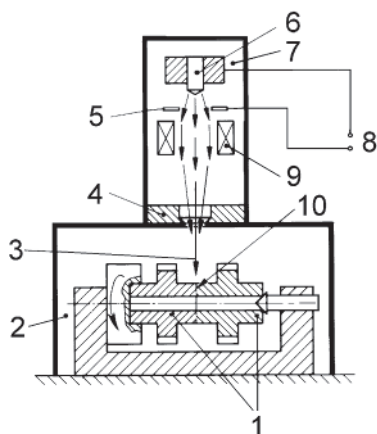

#### **Key**

1	workpiece	5	anode	8	power source
2	work chamber	6	cathode	9	focusing coil
3	electron beam	7	vacuum chamber	10	weld
4	deflector coil				

**Figure 51 — Electron beam welding**

#### 2.2.2.5.2

#### **electron beam welding in vacuum**

*electron beam welding* (2.2.2.5.1) performed in vacuum

#### 2.2.2.5.3

#### **electron beam welding in atmosphere**

*electron beam welding* (2.2.2.5.1) performed in atmosphere

#### 2.2.2.5.4

#### **electron beam welding with addition of shielding gases**

*electron beam welding* (2.2.2.5.1) where a shielding gas is used

#### 2.2.2.5.5

#### **laser welding**

*fusion welding* (2.1.3) using a coherent beam of monochromatic light

Note 1 to entry: Laser welding is illustrated in [Figure 52](#).



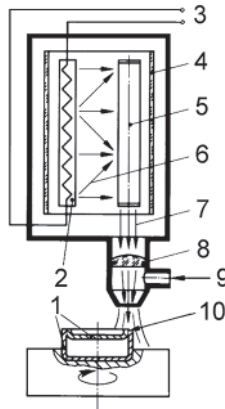

**Key**

1	workpiece	5	laser rod or gas filled tube	8	lense
2	light source	6	light beam	9	shielding gas
3	power source	7	laser beam	10	weld
4	elliptical mirror				

**Figure 52 — Laser welding**

**2.2.2.5.6**

**solid state laser welding**

*laser welding* (2.2.2.5.5) in which the lasing medium is a solid state crystal

**2.2.2.5.7**

**gas laser welding**

*laser welding* (2.2.2.5.5) in which the lasing medium is a gas

**2.2.2.5.8**

**diode laser welding**

*laser welding* (2.2.2.5.5) in which the lasing medium is a diode

**2.2.2.5.9**

**light radiation welding**

welding where light radiation focuses the welding energy to the welding point

**2.2.2.5.10**

**infrared welding**

*light radiation welding* (2.2.2.5.9) where the welding energy is achieved by infrared radiation

**2.2.2.6 Energy carrier: movement of a mass**

(No process known so far)

**2.2.2.7 Energy carrier: electric current**

**2.2.2.7.1**

**electroslag welding**

*fusion welding* (2.1.3) using the combined effects of current and electrical resistance in a consumable electrode, or electrodes, and a conducting bath of molten slag through which the electrode passes into the molten pool, both the pool and the slag bath being retained in the joint by cooled shoes which move progressively upwards

Note 1 to entry: After the initial arcing period, the end of the electrode is covered by the rising slag and then melts continuously until the joint is completed. Electrodes can be bare or flux cored strip(s) or plate(s).

Note 2 to entry: Electroslag welding is illustrated in [Figure 53](#).

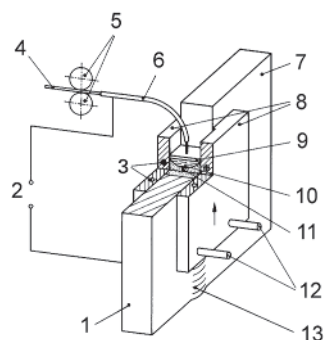

**Key**

- |                 |                    |                  |
|-----------------|--------------------|------------------|
| 1 workpiece     | 6 electrode holder | 10 weld pool     |
| 2 power source  | 7 workpiece        | 11 weld metal    |
| 3 water cooling | 8 sliding shoes    | 12 water cooling |
| 4 electrode     | 9 slag bath        | 13 weld          |
| 5 feed rolls    |                    |                  |

**Figure 53 — Electroslag welding**

**2.2.2.7.2**

**electroslag welding with strip electrode**

*electroslag welding* ([2.2.2.7.1](#)) using a strip electrode

**2.2.2.7.3**

**electroslag welding with wire electrode**

*electroslag welding* ([2.2.2.7.1](#)) using a wire electrode

**2.2.2.8 Energy carrier: unspecified**

**2.2.2.8.1**

**hybrid welding**

welding in which two or more welding processes are used simultaneously in the same weld pool

Note 1 to entry: Hybrid welding is illustrated in [Figure 54](#).

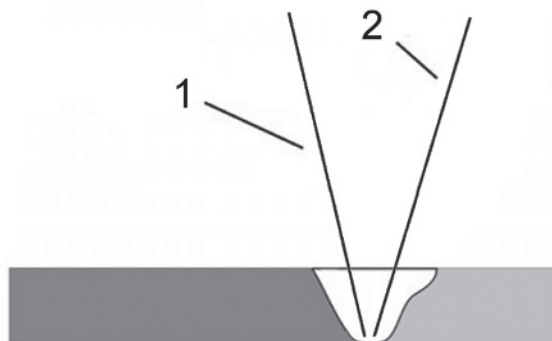

**Key**

- |                     |                     |
|---------------------|---------------------|
| 1 welding process 1 | 2 welding process 2 |
|---------------------|---------------------|

**Figure 54 — Hybrid welding**

**2.2.2.8.2**

**laser-arc hybrid welding**

*hybrid welding* ([2.2.2.8.1](#)) using both laser welding and arc welding

## Annex A (informative)

### Alphabetical index of English terms with French and German translations

English term	Subclause	French translation	German translation
<b>A</b>			
aluminothermic welding	<a href="#">2.2.2.2.2</a>	soudage aluminothermique; soudage par aluminothermie	aluminothermisches Schweißen
arc stud welding	<a href="#">2.2.1.4.3</a>	soudage à l'arc de goujons	Lichtbogenbolzenschweißen
arc welding	<a href="#">2.2.2.4.1</a>	soudage à l'arc	Lichtbogenschweißen
autogenous TIG welding	<a href="#">2.2.2.4.23</a>	soudage TIG autogène; soudage à l'arc autogène sous protection gazeuse inerte avec électrode de tungstène	Wolfram-Inertgasschweißen ohne Schweißzusatz
<b>C</b>			
capacitor discharge drawn arc stud welding	<a href="#">2.2.1.4.6</a>	soudage à l'arc de goujons par étirement de l'arc et décharge de condensateurs	Kondensatorentladungs-Bolzenschweißen mit Hubzündung
capacitor discharge stud welding with tip ignition	<a href="#">2.2.1.4.7</a>	soudage à l'arc des goujons par décharge de condensateurs avec amorçage par contact	Kondensatorentladungs-Bolzenschweißen mit Spitzenzündung
cold pressure extrusion welding	<a href="#">2.2.1.6.16</a>	soudage à froid par cofilage	Kaltfließpressschweißen
cold pressure welding	<a href="#">2.2.1.6.14</a>	soudage avec pression à froid	Kaltpressschweißen
cold upset welding	<a href="#">2.2.1.6.15</a>	soudage à froid par refoulement; soudage à froid par écrasement	Anstauchschweißen
continuous drive friction welding	See direct drive friction welding ( <a href="#">2.2.1.6.4</a> )		
<b>D</b>			
diffusion welding	<a href="#">2.2.1.8.1</a>	soudage par diffusion	Diffusionsschweißen
diode laser welding	<a href="#">2.2.2.5.8</a>	soudage avec laser à diodes	Dioden-Laserstrahlschweißen; Halbleiter-Laserstrahlschweißen
direct drive friction welding	<a href="#">2.2.1.6.4</a>	soudage par friction avec entraînement direct	Reibschweißen mit kontinuierlichem Antrieb
drawn arc stud welding	<a href="#">2.2.1.4.4</a>	soudage de goujons par étirement de l'arc; soudage de goujons par étirement de l'arc avec bague en céramique ou gaz de protection	Hubzündungs-Bolzenschweißen mit Keramikring oder Schutzgas
drawn arc stud welding with ceramic ferrule or shielding gas	See drawn arc stud welding ( <a href="#">2.2.1.4.4</a> )		
drawn arc stud welding with fusible collar	<a href="#">2.2.1.4.8</a>	soudage de goujons par étirement de l'arc avec bague fusible	Bolzenschweißen mit Ringzündung
<b>E</b>			
electrogas welding	<a href="#">2.2.2.4.20</a>	soudage électrogaz	Elektrogasschweißen
electron beam welding	<a href="#">2.2.2.5.1</a>	soudage par faisceau d'électrons	Elektronenstrahlschweißen

English term	Subclause	French translation	German translation
electron beam welding in atmosphere	<a href="#">2.2.2.5.3</a>	soudage par faisceau d'électrons en atmosphère	Elektronenstrahlschweißen in Atmosphäre
electron beam welding in vacuum	<a href="#">2.2.2.5.2</a>	soudage par faisceau d'électrons sous vide	Elektronenstrahlschweißen im Vakuum
electron beam welding with addition of shielding gases	<a href="#">2.2.2.5.4</a>	soudage par faisceau d'électrons sous protection gazeuse; soudage par faisceau d'électrons avec addition de gaz de protection	Elektronenstrahlschweißen unter Schutzgas
electroslag welding	<a href="#">2.2.2.7.1</a>	soudage sous laitier (électroconducteur); soudage électroslag	Elektroschlackeschweißen
electroslag welding with strip electrode	<a href="#">2.2.2.7.2</a>	soudage sous laitier (électroconducteur) avec électrode en feuillard; soudage électroslag avec électrode en bande	Elektroschlackeschweißen mit Bandelektrode
electroslag welding with wire electrode	<a href="#">2.2.2.7.3</a>	soudage sous laitier (électroconducteur) avec fil-électrode; soudage électroslag avec fil-électrode	Elektroschlackeschweißen mit Drahtelektrode
energy carrier	<a href="#">2.1.4</a>	porteur d'énergie	Energieträger
explosion welding	<a href="#">2.2.1.6.11</a>	soudage par explosion	Sprengschweißen
explosive welding	See explosion welding ( <a href="#">2.2.1.6.11</a> )		
<b>F</b>			
flash welding	<a href="#">2.2.1.7.11</a>	soudage par étincelage	Abtrennstumpfschweißen
flow welding	<a href="#">2.2.2.2.1</a>	soudage à la poche	Gießschmelzschweißen
flow welding with pressure	<a href="#">2.2.1.2.1</a>	soudage à la poche avec pression	Gießpressschweißen
foil butt-seam welding	<a href="#">2.2.1.7.8</a>	soudage en bout à la molette avec feuillard; soudage en bout au galet avec feuillard	Folien-Stumpfnahschweißen
forge welding	<a href="#">2.2.1.6.13</a>	soudage par forgeage	Feuerschweißen
friction stir welding	<a href="#">2.2.1.6.9</a>	soudage par friction-malaxage; FSW; soudage thixotropique	Rührreibschweißen
friction stud welding	<a href="#">2.2.1.6.8</a>	soudage par friction des goujons	Reibbolzenschweißen
friction welding	<a href="#">2.2.1.6.3</a>	soudage par friction	Reibschweißen
fusion welding	<a href="#">2.1.3</a>	soudage par fusion	Schmelzschweißen
<b>G</b>			
gas laser welding	<a href="#">2.2.2.5.7</a>	soudage avec laser à gaz	Gas-Laserstrahlschweißen
gas metal arc welding	See gas-shielded metal arc welding ( <a href="#">2.2.2.4.13</a> )		
gas tungsten arc welding	See gas-shielded arc welding with non-consumable tungsten electrode ( <a href="#">2.2.2.4.21</a> )		
gas welding	<a href="#">2.2.2.3.1</a>	soudage aux gaz	Gasschmelzschweißen
gas-shielded arc welding with non-consumable tungsten electrode	<a href="#">2.2.2.4.21</a>	soudage à l'arc sous protection gazeuse avec électrode non-fusible; soudage à l'arc sous protection gazeuse avec électrode de tungstène; soudage à l'arc sous protection gazeuse avec électrode réfractaire	Wolfram-Schutzgasschweißen

English term	Subclause	French translation	German translation
gas-shielded arc welding with non-consumable tungsten electrode using active gas	<a href="#">2.2.2.4.27</a>	soudage à l'arc sous protection gazeuse active avec électrode de tungstène (non-fusible); soudage TAG	Wolfram-Schutzgasschweißen mit aktiven Gasanteilen im ansonsten inerten Schutzgas
gas-shielded metal arc welding	<a href="#">2.2.2.4.13</a>	soudage à l'arc sous protection gazeuse avec fil-électrode fusible; soudage MIG/MAG	Metall-Schutzgasschweißen
gravity (arc) welding with covered electrode	See gravity welding ( <a href="#">2.2.2.4.5</a> )		
gravity welding	<a href="#">2.2.2.4.5</a>	soudage à l'arc par gravité	Schwerkraftlichtbogenschweißen
<b>H</b>			
heated element welding	<a href="#">2.2.1.1.1</a>	soudage par élément chauffant	Heizelementschweißen
heated nozzle welding	<a href="#">2.2.1.1.3</a>	soudage avec buse chauffante	Düsenchweißen
heated wedge welding	<a href="#">2.2.1.1.2</a>	soudage par coin chauffant	Heizkeilschweißen
HF induction welding	<a href="#">2.2.1.7.18</a>	soudage par induction haute-fréquence; soudage par induction HF	Induktives Hochfrequenzschweißen
HF resistance welding	<a href="#">2.2.1.7.14</a>	soudage par résistance à haute fréquence; soudage par résistance HF	Widerstandspressschweißen mit Hochfrequenz
high frequency induction welding	See HF induction welding ( <a href="#">2.2.1.7.18</a> )		
high frequency resistance welding	See HF resistance welding ( <a href="#">2.2.1.7.14</a> )		
hot pressure welding	<a href="#">2.2.1.8.2</a>	soudage avec pression à chaud	Heißpressschweißen
hybrid welding	<a href="#">2.2.2.8.1</a>	soudage hybride	Hybridschweißen
<b>I</b>			
induction butt welding	<a href="#">2.2.1.7.16</a>	soudage en bout par induction	induktives Stumpfschweißen
induction seam welding	<a href="#">2.2.1.7.17</a>	soudage à la molette par induction; soudage au galet par induction	induktives Rollennahtschweißen
induction welding	<a href="#">2.2.1.7.15</a>	soudage par induction	Induktionsschweißen
inertia friction welding	<a href="#">2.2.1.6.5</a>	soudage par friction inertielle; soudage par friction par inertie	Reibschweißen mit Schwungradantrieb
infrared welding	<a href="#">2.2.2.5.10</a>	soudage par rayonnement infrarouge	Infrarotschweißen
<b>L</b>			
lap seam welding	<a href="#">2.2.1.7.4</a>	soudage à la molette par recouvrement; soudage au galet par recouvrement	Überlapp-Rollennahtschweißen
laser-arc hybrid welding	<a href="#">2.2.2.8.2</a>	soudage hybride laser-arc	Laserstrahl-Lichtbogen-Hybridschweißen
laser welding	<a href="#">2.2.2.5.5</a>	soudage laser	Laserstrahlschweißen
light radiation welding	<a href="#">2.2.2.5.9</a>	soudage par rayonnement lumineux	Lichtstrahlschweißen
<b>M</b>			
MAG welding with flux cored electrode	<a href="#">2.2.2.4.18</a>	soudage MAG avec fil fourré de flux; soudage à l'arc sous protection de gaz actif avec fil-électrode fourré de flux	Metall-Aktivgasschweißen mit schweisspulvergefüllter Drahtelektrode

English term	Subclause	French translation	German translation
MAG welding with metal cored electrode	<a href="#">2.2.2.4.19</a>	soudage MAG avec fil fourré de poudre métallique; soudage à l'arc sous protection de gaz actif avec fil-électrode fourré de poudre métallique	Metall-Aktivgasschweißen mit metallpulvergefüllter Drahtelektrode
MAG welding with solid wire electrode	<a href="#">2.2.2.4.17</a>	soudage MAG (avec fil-électrode fusible); soudage à l'arc sous protection de gaz actif avec fil-électrode fusible	Metall-Aktivgasschweißen mit Massivdrahtelektrode
magnetic impulse welding	See magnetic pulse welding ( <a href="#">2.2.1.6.12</a> )		
magnetic pulse welding	<a href="#">2.2.1.6.12</a>	soudage par impulsion magnétique	Magnetimpulsschweißen
magnetically impelled arc butt welding	See magnetically impelled arc welding ( <a href="#">2.2.1.4.1</a> )		
magnetically impelled arc welding	<a href="#">2.2.1.4.1</a>	soudage à l'arc tournant	Lichtbogenschweißen mit magnetisch bewegtem Lichtbogen
manual metal arc welding	<a href="#">2.2.2.4.4</a>	soudage manuel à l'arc avec électrode enrobée; soudage à l'électrode enrobée	Lichtbogenhandschweißen
mash seam welding	<a href="#">2.2.1.7.5</a>	soudage à la molette par écrasement; soudage au galet par écrasement	Quetschnahtschweißen
metal arc welding	<a href="#">2.2.2.4.2</a>	soudage à l'arc avec électrode fusible	Metall-Lichtbogenschweißen
metal arc welding without gas protection	<a href="#">2.2.2.4.3</a>	soudage à l'arc avec électrode fusible sans protection gazeuse	Metall-Lichtbogenschweißen ohne Gasschutz
metal welding	<a href="#">2.1.1</a>	soudage des métaux	Metallschweißen
MIG welding with flux cored wire electrode	<a href="#">2.2.2.4.15</a>	soudage MIG avec fil fourré de flux; soudage à l'arc sous protection de gaz inerte avec fil-électrode fourré de flux	Metall-Inertgasschweißen mit schweißpulvergefüllter Drahtelektrode
MIG welding with metal cored wire electrode	<a href="#">2.2.2.4.16</a>	soudage MIG avec fil fourré de poudre métallique; soudage à l'arc sous protection de gaz inerte avec fil-électrode fourré de poudre métallique	Metall-Inertgasschweißen mit metallpulvergefüllter Drahtelektrode
MIG welding with solid wire electrode	<a href="#">2.2.2.4.14</a>	soudage MIG (avec fil-électrode fusible); soudage à l'arc sous protection de gaz inerte avec fil-électrode fusible)	Metall-Inertgasschweißen mit Massivdrahtelektrode
MIG/MAG welding	See gas-shielded metal arc welding ( <a href="#">2.2.2.4.13</a> )		
<b>N</b>			
nail head welding	<a href="#">2.2.1.1.4</a>	soudage en tête de clou	Nagelkopfschweißen
<b>O</b>			
orbital friction welding	<a href="#">2.2.1.6.6</a>	soudage par friction orbitale	Orbitalreibschweißen
oxyacetylene welding	<a href="#">2.2.2.3.2</a>	soudage oxyacétylénique	Gasschweißen mit Sauerstoff-Acetylen-Flamme
oxyfuel gas pressure welding	<a href="#">2.2.1.3.1</a>	soudage aux gaz avec pression	Gaspressschweißen
oxyhydrogen welding	<a href="#">2.2.2.3.4</a>	soudage oxhydrique	Gasschweißen mit Sauerstoff-Wasserstoff-Flamme

English term	Subclause	French translation	German translation
oxypropane welding	<a href="#">2.2.2.3.3</a>	soudage oxypropane	Gasschweißen mit Sauerstoff-Propan-Flamme
<b>P</b>			
percussion welding	<a href="#">2.2.1.4.2</a>	soudage par percussion	Entladungsschweißen
plasma arc welding	<a href="#">2.2.2.4.28</a>	soudage plasma	Plasmaschweißen
plasma arc welding with non-transferred arc	<a href="#">2.2.2.4.32</a>	soudage plasma avec arc non transféré	Plasmalichtbogenschweißen mit nicht übertragenem Lichtbogen
plasma arc welding with partially transferred arc	<a href="#">2.2.2.4.33</a>	soudage plasma avec arc semi-transféré	Plasmastrahl-Plasmalichtbogenschweißen
plasma arc welding with transferred arc	<a href="#">2.2.2.4.31</a>	soudage plasma avec arc transféré	Plasmalichtbogenschweißen mit übertragenem Lichtbogen
plasma jet welding	See plasma arc welding with non-transferred arc ( <a href="#">2.2.2.4.32</a> )		
plasma MIG welding	<a href="#">2.2.2.4.29</a>	soudage plasma-MIG	Plasma-MIG-Schweißen
powder plasma arc welding	<a href="#">2.2.2.4.30</a>	soudage plasma avec apport de poudre	Pulver-Plasmalichtbogenschweißen
prep-lap seam welding	<a href="#">2.2.1.7.6</a>	soudage à la molette sur bords préparés; soudage au galet sur bords préparés	Rollennahtschweißen mit Kanten-vorbereitung
projection welding	<a href="#">2.2.1.7.10</a>	soudage par bossages	Buckelschweißen
<b>R</b>			
radial friction welding	<a href="#">2.2.1.6.7</a>	soudage par friction radiale	Radialreibschweißen
resistance butt welding	<a href="#">2.2.1.7.12</a>	soudage en bout par résistance pure	Pressstumpfschweißen
resistance seam welding	<a href="#">2.2.1.7.3</a>	soudage par résistance à la molette	Rollennahtschweißen
resistance spot welding	<a href="#">2.2.1.7.2</a>	soudage par résistance par points	Widerstandspunktschweißen
resistance stud welding	<a href="#">2.2.1.7.13</a>	soudage par résistance des goujons	Widerstandsbolzenschweißen
resistance welding	<a href="#">2.2.1.7.1</a>	soudage par résistance	Widerstandsschweißen
roll welding	<a href="#">2.2.1.8.3</a>	soudage longitudinal avec pression à chaud	Walzschweißen
<b>S</b>			
seam welding with strip	<a href="#">2.2.1.7.9</a>	soudage à la molette avec feuillard; soudage au galet avec feuillard	Folien-Überlappnahtschweißen
self-shielded tubular cored arc welding	<a href="#">2.2.2.4.6</a>	soudage à l'arc avec fil fourré sans gaz de protection; soudage à l'arc avec fil fourré auto-protecteur	Metall-Lichtbogenschweißen mit Fülldrahtelektrode ohne Schutzgas
shock welding	<a href="#">2.2.1.6.10</a>	soudage par choc	Schockschweißen
short-cycle drawn arc stud welding	<a href="#">2.2.1.4.5</a>	soudage à l'arc de goujons par étirement de l'arc avec cycle court	Kurzzeit-Bolzenschweißen mit Hubzündung
solid state laser welding	<a href="#">2.2.2.5.6</a>	soudage avec laser à solide	Festkörper-Laserstrahlschweißen
submerged arc welding	<a href="#">2.2.2.4.7</a>	soudage à l'arc sous flux (en poudre); soudage à l'arc submergé	Unterpulverschweißen
submerged arc welding with cored strip electrode	<a href="#">2.2.2.4.12</a>	soudage à l'arc sous flux (en poudre) avec électrode en feuillard fourrée	Unterpulverschweißen mit Füllbandelektrode



English term	Subclause	French translation	German translation
submerged arc welding with metal powder addition	<a href="#">2.2.2.4.10</a>	soudage à l'arc sous flux (en poudre) avec addition de poudre métallique; soudage à l'arc submergé avec addition de poudre métallique	Unterpulverschweißen mit Metallpulverzusatz
submerged arc welding with solid wire electrode	<a href="#">2.2.2.4.8</a>	soudage à l'arc sous flux (en poudre) avec un seul fil; soudage à l'arc submergé avec un seul fil-électrode	Unterpulverschweißen mit Drahtelektrode
submerged arc welding with strip electrode	<a href="#">2.2.2.4.9</a>	soudage à l'arc sous flux (en poudre) avec électrode en feuillard; soudage à l'arc submergé avec électrode en feuillard; soudage à l'arc submergé avec électrode en bande	Unterpulverschweißen mit Bandelektrode
submerged arc welding with tubular cored electrode	<a href="#">2.2.2.4.11</a>	soudage à l'arc sous flux (en poudre) avec fil fourré; soudage à l'arc submergé avec fil fourré	Unterpulverschweißen mit Fülldrahtelektrode
<b>T</b>			
TAG welding	See gas-shielded arc welding with non-consumable tungsten electrode using active gas ( <a href="#">2.2.2.4.27</a> )		
TIG welding using reducing gas and solid filler material (wire/rod)	<a href="#">2.2.2.4.25</a>	soudage TIG avec gaz réducteur et produit d'apport (fil/baguette) massif	Wolfram-Schutzgasschweißen mit reduzierenden Gasanteilen im ansonsten inerten Schutzgas und Massivdraht- oder Massivstabzusatz
TIG welding using reducing gas and tubular cored filler material (wire/rod)	<a href="#">2.2.2.4.26</a>	soudage TIG avec gaz réducteur et fil fourré ou baguette fourrée	Wolfram-Schutzgasschweißen mit reduzierenden Gasanteilen im ansonsten inerten Schutzgas und Fülldraht- oder Füllstabzusatz
TIG welding with solid filler material (wire/rod)	<a href="#">2.2.2.4.22</a>	soudage TIG (avec produit d'apport (fil/baguette) massif)	Wolfram-Inertgasschweißen mit Massivdraht- oder Massivstabzusatz
TIG welding with tubular cored filler material (wire/rod)	<a href="#">2.2.2.4.24</a>	soudage TIG avec fil fourré ou baguette fourrée; soudage à l'arc sous protection gazeuse inerte avec électrode de tungstène et fil fourré ou baguette fourrée	Wolfram-Inertgasschweißen mit Fülldraht oder Füllstabzusatz
<b>U</b>			
ultrasonic hot welding	<a href="#">2.2.1.6.2</a>	soudage par ultrasons à chaud	Ultraschallwarmschweißen
ultrasonic welding	<a href="#">2.2.1.6.1</a>	soudage par ultrasons	Ultraschallschweißen
<b>W</b>			
welding with pressure	<a href="#">2.1.2</a>	soudage avec pression	Pressschweißen
wire seam welding	<a href="#">2.2.1.7.7</a>	soudage à la molette avec fil	Rollennahtschweißen mit Drahtelektrode

## Annex B (informative)

### Alphabetical index of welding processes related terms defined in ISO 857-1:1998 that were not included in this part of ISO/ TR 25901

The terms from ISO 857-1:1998 that are not included in the body of this part of ISO/TR 25901 are either listed below when they have become obsolete or redundant or are covered in another part of this Technical Report.

Term	Definition	Origin	Subclause
<b>R</b>			
roll cladding	welding with pressure in which the union between a parent and cladding material is obtained after heating the workpieces and by the subsequent application of mechanically operated rolls	ISO 857-1:1998	4.1.8.3
<b>S</b>			
submerged arc welding with multiple wire electrode (123)	submerged arc welding using more than one wire electrode	ISO 857-1:1998	4.2.4.10
<b>T</b>			
tubular (flux)-cored metal-arc welding with inert gas shield (137)	metal-arc inert gas welding using a tubular (flux)-cored electrode	ISO 857-1:1998	4.2.4.17

## Bibliography

- [1] ISO 4063, *Welding and allied processes — Nomenclature of processes and reference numbers*
- [2] ISO 6520-1, *Welding and allied processes — Classification of geometric imperfections in metallic materials — Part 1: Fusion welding*
- [3] ISO 6520-2, *Welding and allied processes — Classification of geometric imperfections in metallic materials — Part 2: Welding with pressure*
- [4] ISO 14917, *Thermal spraying — Terminology, classification*
- [5] ISO 15296, *Gas welding equipment — Vocabulary — Terms used for gas welding equipment*
- [6] ISO 17658, *Welding — Imperfections in oxyfuel flame cuts, laser beam cuts and plasma cuts — Terminology*
- [7] ISO 17677-1, *Resistance welding — Vocabulary — Part 1: Spot, projection and seam welding*
- [8] ISO 25239-1, *Friction stir welding — Aluminium — Part 1: Vocabulary*
- [9] IEC 60050-851, *International electrotechnical vocabulary — Part 851: Electric welding*
- [10] EN 14610, *Welding and allied processes — Definitions of metal welding processes*





# British Standards Institution (BSI)

BSI is the national body responsible for preparing British Standards and other standards-related publications, information and services.

BSI is incorporated by Royal Charter. British Standards and other standardization products are published by BSI Standards Limited.

## About us

We bring together business, industry, government, consumers, innovators and others to shape their combined experience and expertise into standards-based solutions.

The knowledge embodied in our standards has been carefully assembled in a dependable format and refined through our open consultation process. Organizations of all sizes and across all sectors choose standards to help them achieve their goals.

## Information on standards

We can provide you with the knowledge that your organization needs to succeed. Find out more about British Standards by visiting our website at [bsigroup.com/standards](http://bsigroup.com/standards) or contacting our Customer Services team or Knowledge Centre.

## Buying standards

You can buy and download PDF versions of BSI publications, including British and adopted European and international standards, through our website at [bsigroup.com/shop](http://bsigroup.com/shop), where hard copies can also be purchased.

If you need international and foreign standards from other Standards Development Organizations, hard copies can be ordered from our Customer Services team.

## Subscriptions

Our range of subscription services are designed to make using standards easier for you. For further information on our subscription products go to [bsigroup.com/subscriptions](http://bsigroup.com/subscriptions).

With **British Standards Online (BSOL)** you'll have instant access to over 55,000 British and adopted European and international standards from your desktop. It's available 24/7 and is refreshed daily so you'll always be up to date.

You can keep in touch with standards developments and receive substantial discounts on the purchase price of standards, both in single copy and subscription format, by becoming a **BSI Subscribing Member**.

**PLUS** is an updating service exclusive to BSI Subscribing Members. You will automatically receive the latest hard copy of your standards when they're revised or replaced.

To find out more about becoming a BSI Subscribing Member and the benefits of membership, please visit [bsigroup.com/shop](http://bsigroup.com/shop).

With a **Multi-User Network Licence (MUNL)** you are able to host standards publications on your intranet. Licences can cover as few or as many users as you wish. With updates supplied as soon as they're available, you can be sure your documentation is current. For further information, email [bsmusales@bsigroup.com](mailto:bsmusales@bsigroup.com).

## Revisions

Our British Standards and other publications are updated by amendment or revision.

We continually improve the quality of our products and services to benefit your business. If you find an inaccuracy or ambiguity within a British Standard or other BSI publication please inform the Knowledge Centre.

## Copyright

All the data, software and documentation set out in all British Standards and other BSI publications are the property of and copyrighted by BSI, or some person or entity that owns copyright in the information used (such as the international standardization bodies) and has formally licensed such information to BSI for commercial publication and use. Except as permitted under the Copyright, Designs and Patents Act 1988 no extract may be reproduced, stored in a retrieval system or transmitted in any form or by any means – electronic, photocopying, recording or otherwise – without prior written permission from BSI. Details and advice can be obtained from the Copyright & Licensing Department.

## Useful Contacts:

### Customer Services

**Tel:** +44 845 086 9001

**Email (orders):** [orders@bsigroup.com](mailto:orders@bsigroup.com)

**Email (enquiries):** [cservices@bsigroup.com](mailto:cservices@bsigroup.com)

### Subscriptions

**Tel:** +44 845 086 9001

**Email:** [subscriptions@bsigroup.com](mailto:subscriptions@bsigroup.com)

### Knowledge Centre

**Tel:** +44 20 8996 7004

**Email:** [knowledgecentre@bsigroup.com](mailto:knowledgecentre@bsigroup.com)

### Copyright & Licensing

**Tel:** +44 20 8996 7070

**Email:** [copyright@bsigroup.com](mailto:copyright@bsigroup.com)

## BSI Group Headquarters

389 Chiswick High Road London W4 4AL UK