



BSI Standards Publication

**Impact test procedures for
road vehicles — Rear seat
positioning procedures for
Hybrid III 5th percentile
female dummy**

National foreword

This Published Document is the UK implementation of ISO/TR 17950:2016.

The UK participation in its preparation was entrusted to Technical Committee AUE/7, Automobile occupant restraint systems.

A list of organizations represented on this committee can be obtained on request to its secretary.

This publication does not purport to include all the necessary provisions of a contract. Users are responsible for its correct application.

© The British Standards Institution 2016.

Published by BSI Standards Limited 2016

ISBN 978 0 580 91727 1

ICS 43.180

Compliance with a British Standard cannot confer immunity from legal obligations.

This Published Document was published under the authority of the Standards Policy and Strategy Committee on 30 November 2016.

Amendments/corrigenda issued since publication

Date	Text affected
-------------	----------------------

TECHNICAL REPORT

ISO/TR 17950

First edition
2016-11-15

Impact test procedures for road vehicles — Rear seat positioning procedures for Hybrid III 5th percentile female dummy

*Procédures de chocs pour les véhicules routiers - Procédures
d'installation et de positionnement en places arrières des mannequins
Hybrid III 5ème percentile femme*



Reference number
ISO/TR 17950:2016(E)

© ISO 2016



COPYRIGHT PROTECTED DOCUMENT

© ISO 2016, Published in Switzerland

All rights reserved. Unless otherwise specified, no part of this publication may be reproduced or utilized otherwise in any form or by any means, electronic or mechanical, including photocopying, or posting on the internet or an intranet, without prior written permission. Permission can be requested from either ISO at the address below or ISO's member body in the country of the requester.

ISO copyright office
Ch. de Blandonnet 8 • CP 401
CH-1214 Vernier, Geneva, Switzerland
Tel. +41 22 749 01 11
Fax +41 22 749 09 47
copyright@iso.org
www.iso.org

Contents

	Page
Foreword	iv
1 Scope	1
2 Normative references	1
3 Terms and definitions	1
4 Symbols and abbreviated terms	1
5 Recommendations	2
5.1 General	2
5.2 Position of the rear seats	2
5.2.1 Rear seats	2
5.2.2 Rear seatbacks	2
5.2.3 Rear head restraints	3
5.2.4 Seat supports	3
5.2.5 Seatbelt upper torso adjustment	3
5.2.6 Armrests	3
5.2.7 Defining the seat centre reference line	3
5.3 Design H-Point Determination	3
5.3.1 Determining the H-point of SAE J826 device	3
5.3.2 Method for deriving the Design H Points of Hybrid III 5th percentile female Dummies for rear seat position	4
5.4 Installation and positioning of Dummy	5
5.4.1 Installation method for Hybrid III 5th percentile female Dummies	5
5.4.2 Fastening of seatbelts	8
Bibliography	9

Foreword

ISO (the International Organization for Standardization) is a worldwide federation of national standards bodies (ISO member bodies). The work of preparing International Standards is normally carried out through ISO technical committees. Each member body interested in a subject for which a technical committee has been established has the right to be represented on that committee. International organizations, governmental and non-governmental, in liaison with ISO, also take part in the work. ISO collaborates closely with the International Electrotechnical Commission (IEC) on all matters of electrotechnical standardization.

The procedures used to develop this document and those intended for its further maintenance are described in the ISO/IEC Directives, Part 1. In particular the different approval criteria needed for the different types of ISO documents should be noted. This document was drafted in accordance with the editorial rules of the ISO/IEC Directives, Part 2 (see www.iso.org/directives).

Attention is drawn to the possibility that some of the elements of this document may be the subject of patent rights. ISO could not be held responsible for identifying any or all such patent rights. Details of any patent rights identified during the development of the document will be in the Introduction and/or on the ISO list of patent declarations received (see www.iso.org/patents).

Any trade name used in this document is information given for the convenience of users and does not constitute an endorsement.

For an explanation on the meaning of ISO specific terms and expressions related to conformity assessment, as well as information about ISO's adherence to the WTO principles in the Technical Barriers to Trade (TBT) see the following URL: [Foreword - Supplementary information](#)

ISO/TR 17950 was prepared by Technical Committee ISO/TC 22, *Road vehicles*, Subcommittee SC 36, *Safety and impact testing*.

Impact test procedures for road vehicles — Rear seat positioning procedures for Hybrid III 5th percentile female dummy

1 Scope

This document specifies the conditions for the recommended placement of the Hybrid III 5th percentile female frontal impact dummy (HIII5F) when used in forward-facing outboard 2nd row rear seating positions of passenger cars (M Category) for frontal impact testing. For example:

- Frontal Impact 0° and Pole (ISO 3560)
- Frontal Impact Offset Deformable Barrier (ISO 15828)

2 Normative references

There are no normative references in this document.

3 Terms and definitions

For the purposes of this document, the following terms and definitions apply.

ISO and IEC maintain terminological databases for use in standardization at the following addresses:

- IEC Electropedia: available at <http://www.electropedia.org/>
- ISO Online browsing platform: available at <http://www.iso.org/obp>

2.1

H points of Hybrid III 5th percentile female dummies for rear seat position design H point

locations of the Hybrid III 5th dummy H point on a seat adjusted to the manufacturer's specification for a 5% female

Note 1 to entry: The H point is the point of the H joint.

Note 2 to entry: The design H-point is defined as the H-point of SAE J826 device corrected in accordance with 6.2.2.

2.2

Seat Reference Point

marked point at the side of the seat near the H-point

4 Symbols and abbreviated terms

- X forward direction of the vehicle
- Z downward direction of the vehicle
- SRP Seat Reference Point

5 Recommendations

5.1 General

It is recommended to start with the positioning of the rear outboard dummies to facilitate the placement of all dummies.

5.2 Position of the rear seats

5.2.1 Rear seats

Longitudinal seat adjustment should be positioned according to the design longitudinal position for Hybrid III 5th percentile female dummy defined by car manufacturer. If no design position is available, the seat should be adjusted as close as possible to the mid-track position.

Vertical seat adjustment should be positioned in the design position defined by car manufacturer. If no design position is available, the seat should be adjusted as close as possible to the lowest position.

If pitch angle can be adjusted independently, it should be adjusted according to the design position defined by car manufacturer. If no design position is available, it should be as close as possible to the mid-angled position.

In absence of any manufacture specifications the default procedure should be:

- 1) The seat control that primarily moves the seat vertically should be used to adjust the seat reference point to the upper most vertical location.
- 2) The seat control that primarily moves the seat fore-aft should be used to adjust the seat reference point defined to the rear most location.
- 3) The range of angles of the seat cushion pitch referring to the line and using only the control(s) that primarily adjust(s) the cushion pitch should be determined and recorded, and the set cushion pitch should be as close as possible to the mid-angle.
- 4) The seat control that primarily moves the seat vertically should be used to adjust the seat reference point to the lowest vertical location. A verification that you are still at the rearmost seat track location should be conducted. The X position should be recorded.
- 5) The seat control that primarily moves the seat fore-aft to adjust the seat reference point to the forward most location should be used and the X position recorded.
- 6) The midpoint of X-positions recorded in 4.) and 5.) should be calculated and marked.
- 7) The seat control that primarily moves the seat fore-aft to adjust the seat reference point to the X position marked in step 6 (-0/+2 mm) should be used, or, if not possible, to the first X possible position rearward the marked position in step 6. If the seat cannot be placed exactly at the midpoint the next closest available rearward setting should be selected.

NOTE For some vehicles this final step changes the cushion pitch as established in step 7; this is acceptable.

- 8) The test seat position (for example recording the position of the reference point) should be measured and recorded.

5.2.2 Rear seatbacks

If adjustable, the rear seatbacks should be set at the manufacturer's design position. If no design position is available and the seatback is adjustable independently from the fore-aft adjustment, the seatback should be adjusted to 25° or as close as possible.

5.2.3 Rear head restraints

The head restraint position to the vehicle manufacturer's nominal design position for a 5th percentile adult female occupant should be set, or in the lowest locking position if no design position is available.

5.2.4 Seat supports

Any adjustable parts that provide additional support should be positioned so that they are in the lowest or fully retracted positions, e.g.: the seat's adjustable lumbar supports are positioned so that the lumbar supports are in the lowest, retracted or deflated adjustment positions.

5.2.5 Seatbelt upper torso adjustment

Any seatbelt upper torso adjustment at the vehicle manufacturer's design position for the 5th percentile female should be placed. If no design position is specified, the seatbelt upper torso adjustment should be adjusted to the lowest vertical position.

5.2.6 Armrests

If adjustable, the armrests can be stowed

5.2.7 Defining the seat centre reference line

In case of bucket seats:

For future reference, the longitudinal seat center reference line of the seat cushion should be located and marked. The intersection of the vertical longitudinal plane that passes through the SRP and the seat cushion upper surface determines the longitudinal center line of a bucket seat cushion.

In case of bench seats:

For future reference, the longitudinal line on the seat cushion that marks the intersection of the vertical longitudinal plane through the seat cushion upper surface and the mid seating position point should be located and marked. This is defined as:

- 1) designated seating transverse position defined by car manufacturer;
- 2) the middle of the head restraint, if size of the dummy allows it; and
- 3) the middle position of HIII 5th (or SAE dummy), ensuring the best pelvis alignment (minimal yaw in the most rearward position).

5.3 Design H-Point Determination

5.3.1 Determining the H-point of SAE J826 device

The seat in front of the occupant can be displaced to the foremost position to facilitate access to the occupant's seat. Final position of the seat in front of the occupant is based on the test protocol.

- 1) Using only the controls that move the seat fore-aft, the test seat should be returned to the rearmost position to facilitate placement of the SAE H-point manikin.
- 2) The SAE H-point manikin in the seat and position the seat to the test position for the 5th percentile female should be placed, as defined in 6.1.
- 3) The procedure as described in SAE J826 should be followed, except that the length of the lower leg and thigh segments of the SAE H-point manikin should be adjusted to the 50th percentile (418 mm) and 10th percentile (408 mm) positions respectively.
- 4) The seat back angle should be set to achieve the torso angle specified by the manufacturer.

5) The H-point (of the SAE H-point manikin) X, Y and Z coordinates should be recorded.

NOTE If there is not sufficient clearance to permit the placement of the SAE H-point manikin legs or feet, install the manikin with the legs removed.

5.3.2 Method for deriving the Design H Points of Hybrid III 5th percentile female Dummies for rear seat position

The SAE J826 anthropomorphic model with its thigh and leg lengths adjusted to 408 mm and 418 mm respectively should be installed on a seat which is adjusted to the manufacturer’s specification for 5th percentile female, the positions of its H point or those of the H joint (X_{50M}, Z_{50M}) should be determined.

The seat cushion length (“SCL”) shown in [Figure 1](#) is the distance between the front end of the seat cushion (X_{Ft}, Z_{Ft}) and the SAE H-point manikin’s H-point (X_{50M}, Z_{50M}). The front end of the seat cushion should be determined by drawing a perpendicular line from the manikin’s thigh line to the front end of the seat cushion in the vertical plane.

The design H point of a Hybrid III 5th percentile female dummy for rear seat position is derived in accordance with the formula shown in [Table 1](#).

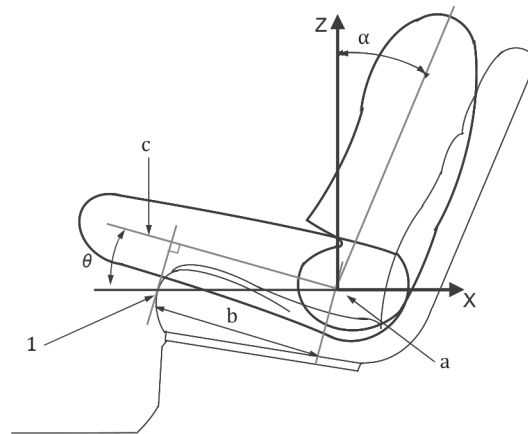

Key

- 1 front end of seat cushion X_{Ft}, Z_{Ft})
- a H point (X_{50M}, Z_{50M})
- b SCL-138 mm
- c Manikin thigh line
- α Seat back angle
- θ Angle of front end and manikin thigh-line

Figure 1 — Definition of SCL (Seat Cushion Length)

$$SCL - 138 = \left(|X_{Ft} - X_{50M}| * \cos \theta - |Z_{Ft} - Z_{50M}| * \sin \theta \right)$$

Table 1 — Design H-point of Hybrid III 5th female

x-axis coordinate X _{5F}	X _{50M} +(138-0,323×SCL)
z-axis coordinate Z _{5F}	Z _{50M}

5.4 Installation and positioning of Dummy

5.4.1 Installation method for Hybrid III 5th percentile female Dummies

The rear seats of the test vehicle should be adjusted to the test position defined in 6.1.

The Hybrid III 5th percentile female dummies should be installed on the rear seats of the test vehicle

5.4.1.1 Seating position

The dummy should be seated in such a position that its longitudinal center line is aligned with the design seat center line. The torso of the dummy should be in contact with the seatback.

The pelvis should be adjusted so that the left and right H-points of the dummy are coincident with the H-points calculated in 6.2.2, within the tolerance defined in [Figure 2](#).

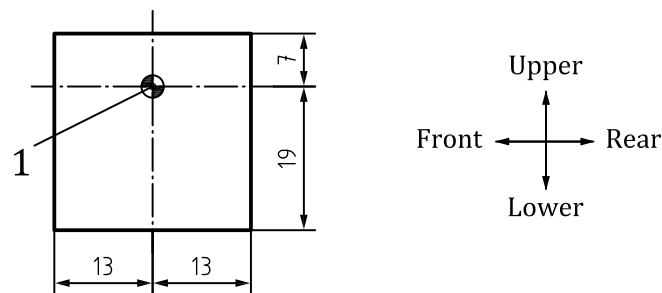

Key

1 design hip point

Figure 2 — H point position tolerance

The pelvic angle should be kept within $20,0^\circ \pm 2,5^\circ$ and recorded.

5.4.1.2 Position of the legs and feet

The initial distance of the outside metal surfaces of the dummy's knees can be $210\text{mm} \pm 5\text{mm}$ as shown in [Figure 3](#). Below; however, this distance does not finalize the position of the knees.

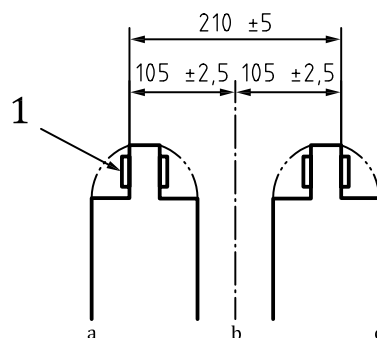

Key

1 outside metal surface

a Left

b Dummy centre

c Right

Figure 3 — Initial knee distance for Hybrid III 5th percentile female

The lower legs should be positioned as forward as possible from the front end of the rear seat cushion while the thighs should be kept in contact with the seat cushion as shown in [Figure 4](#).

While maintaining the thigh angle and the legs parallel to a vertical longitudinal plane, each foot should be lowered until the heel contacts the floor, as shown in [Figure 5](#).

Then each foot should be placed as flat on the floor, as possible as shown in [Figure 6](#).

If a foot does not make contact with the floor, it should be lowered until the calf or the heel makes contact with the front end of the seat. The foot should be positioned parallel to the floor, as shown in [Figure 7](#).

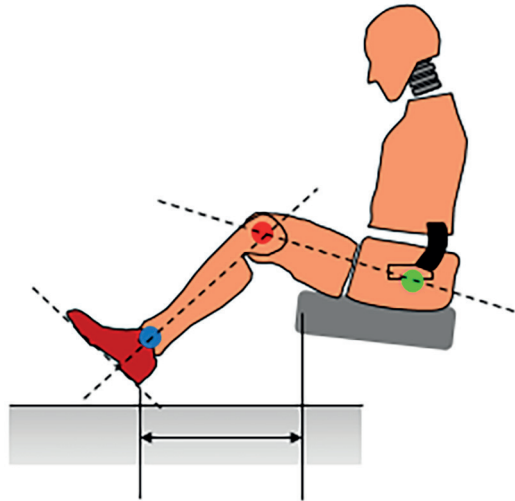

Figure 4 — Lower leg positioning Step 1

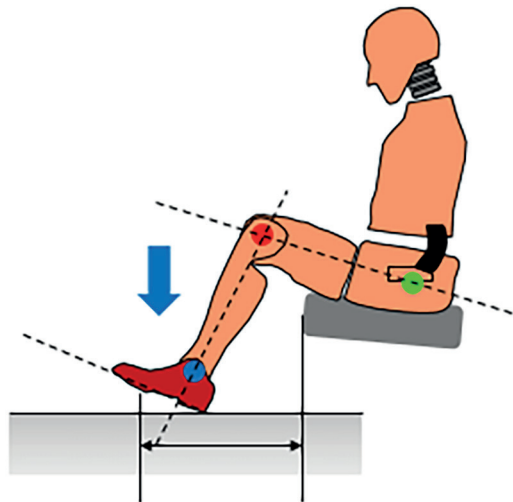

Figure 5 — Lower leg positioning Step 2

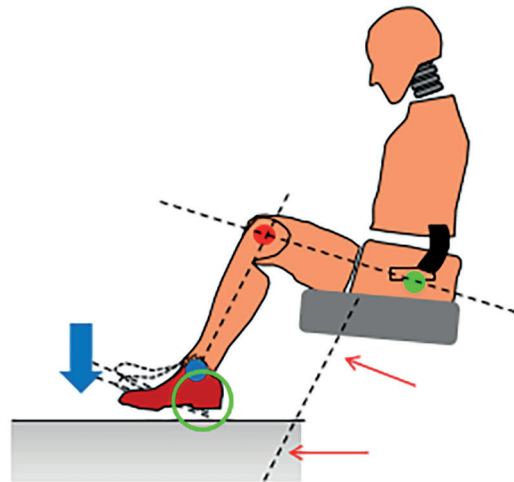

Figure 6 — Lower leg positioning Step 3

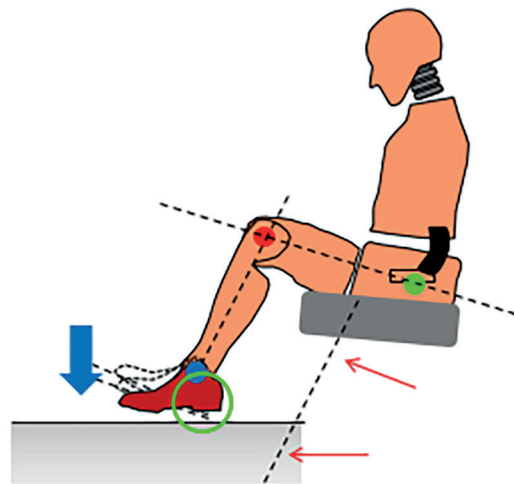

Figure 7 — Lower leg positioning Step 4

5.4.1.3 Initial position of the upper limbs

The upper arms should be adjacent to the torso and in contact with the seatback.

The hands should be placed with the palms in contact with the outside of the legs and the little finger in contact with the seat cushion.

5.4.1.4 Finalization of torso position

H points on outer sides of the pelvis should be verified and aligned to the calculated H points recorded in 6.2.2. Alignment is acceptable if the H points fall within the area around the calculated H points shown in [Figure 2](#). Adjustments should be made as necessary.

The head angle should be aligned to within $\pm 0,5^\circ$ of the horizontal. If the head cannot be levelled to the specified tolerance, the head and torso should be flexed forward and rearward by keeping the pelvis stable. If the head still does not meet the specified tolerance, the pelvis position should be adjusted while remaining within the specified tolerance for the pelvis. Should both attempts be unsuccessful, the neck bracket should be adjusted to level the head to within the required tolerance.

5.4.1.5 Readjustment of the position of the upper limbs

The upper arms should be positioned in contact with the seatback.

The forearms and the hands should be positioned as close as possible to the outer sides of the thighs while the little fingers are lightly in contact with the seat cushion.

If there is interference by a trim part or other parts during the positioning of the upper limbs, the interfered upper limb should be placed on the armrest of the same side to avoid the interference.

5.4.1.6 Readjustment of the foot position

In case the foot position is displaced during the positioning of the torso or other routines, the foot position should be readjusted to the original position prescribed in 6.3.1.2.

5.4.2 Fastening of seatbelts

After installation, the seat belt should be deployed and allowed to fall into its natural position. Adjustments may be made to keep the belt inside the clavicle outer edge and between the breasts.

If the seatbelt assembly is equipped with a device to reduce the seatbelt tension for the occupant, the amount of slack to be introduced is specified by the manufacturer. If the test vehicle is equipped with a seat belt guide (e.g. adjustable guide loop, child comfort guide), it should be adjusted to design position.

Bibliography

- [1] Stapp Car Crash Journal, Vol. 49 (November 2005), pp. 381-421 "*Development of ATD Installation Procedures Based on Rear- Seat Occupant Postures*" Matthew P. Reed et.al University of Michigan Transportation Research Institute
- [2] SAE J826, *Devices for use for defining and measuring vehicle seating accommodation*

British Standards Institution (BSI)

BSI is the national body responsible for preparing British Standards and other standards-related publications, information and services.

BSI is incorporated by Royal Charter. British Standards and other standardization products are published by BSI Standards Limited.

About us

We bring together business, industry, government, consumers, innovators and others to shape their combined experience and expertise into standards-based solutions.

The knowledge embodied in our standards has been carefully assembled in a dependable format and refined through our open consultation process. Organizations of all sizes and across all sectors choose standards to help them achieve their goals.

Information on standards

We can provide you with the knowledge that your organization needs to succeed. Find out more about British Standards by visiting our website at bsigroup.com/standards or contacting our Customer Services team or Knowledge Centre.

Buying standards

You can buy and download PDF versions of BSI publications, including British and adopted European and international standards, through our website at bsigroup.com/shop, where hard copies can also be purchased.

If you need international and foreign standards from other Standards Development Organizations, hard copies can be ordered from our Customer Services team.

Copyright in BSI publications

All the content in BSI publications, including British Standards, is the property of and copyrighted by BSI or some person or entity that owns copyright in the information used (such as the international standardization bodies) and has formally licensed such information to BSI for commercial publication and use.

Save for the provisions below, you may not transfer, share or disseminate any portion of the standard to any other person. You may not adapt, distribute, commercially exploit, or publicly display the standard or any portion thereof in any manner whatsoever without BSI's prior written consent.

Storing and using standards

Standards purchased in soft copy format:

- A British Standard purchased in soft copy format is licensed to a sole named user for personal or internal company use only.
- The standard may be stored on more than 1 device provided that it is accessible by the sole named user only and that only 1 copy is accessed at any one time.
- A single paper copy may be printed for personal or internal company use only.

Standards purchased in hard copy format:

- A British Standard purchased in hard copy format is for personal or internal company use only.
- It may not be further reproduced – in any format – to create an additional copy. This includes scanning of the document.

If you need more than 1 copy of the document, or if you wish to share the document on an internal network, you can save money by choosing a subscription product (see 'Subscriptions').

Reproducing extracts

For permission to reproduce content from BSI publications contact the BSI Copyright & Licensing team.

Subscriptions

Our range of subscription services are designed to make using standards easier for you. For further information on our subscription products go to bsigroup.com/subscriptions.

With **British Standards Online (BSOL)** you'll have instant access to over 55,000 British and adopted European and international standards from your desktop. It's available 24/7 and is refreshed daily so you'll always be up to date.

You can keep in touch with standards developments and receive substantial discounts on the purchase price of standards, both in single copy and subscription format, by becoming a **BSI Subscribing Member**.

PLUS is an updating service exclusive to BSI Subscribing Members. You will automatically receive the latest hard copy of your standards when they're revised or replaced.

To find out more about becoming a BSI Subscribing Member and the benefits of membership, please visit bsigroup.com/shop.

With a **Multi-User Network Licence (MUNL)** you are able to host standards publications on your intranet. Licences can cover as few or as many users as you wish. With updates supplied as soon as they're available, you can be sure your documentation is current. For further information, email subscriptions@bsigroup.com.

Revisions

Our British Standards and other publications are updated by amendment or revision.

We continually improve the quality of our products and services to benefit your business. If you find an inaccuracy or ambiguity within a British Standard or other BSI publication please inform the Knowledge Centre.

Useful Contacts

Customer Services

Tel: +44 345 086 9001

Email (orders): orders@bsigroup.com

Email (enquiries): cservices@bsigroup.com

Subscriptions

Tel: +44 345 086 9001

Email: subscriptions@bsigroup.com

Knowledge Centre

Tel: +44 20 8996 7004

Email: knowledgecentre@bsigroup.com

Copyright & Licensing

Tel: +44 20 8996 7070

Email: copyright@bsigroup.com

BSI Group Headquarters

389 Chiswick High Road London W4 4AL UK