



BSI Standards Publication

Machine tools — Practical guidance and example of risk assessment on electro-discharge machines

National foreword

This Published Document is the UK implementation of ISO/TR 17529:2014.

The UK participation in its preparation was entrusted by Technical Committee MTE/1, Machine tools, to Subcommittee MTE/1/1, Machine tools - Safety.

A list of organizations represented on this committee can be obtained on request to its secretary.

This publication does not purport to include all the necessary provisions of a contract. Users are responsible for its correct application.

© The British Standards Institution 2014.
Published by BSI Standards Limited 2014

ISBN 978 0 580 85727 0
ICS 25.080.01

Compliance with a British Standard cannot confer immunity from legal obligations.

This Published Document was published under the authority of the Standards Policy and Strategy Committee on 30 November 2014.

Amendments issued since publication

Date	Text affected
-------------	----------------------

TECHNICAL REPORT

ISO/TR 17529

First edition
2014-11-15

Machine tools — Practical guidance and example of risk assessment on electro-discharge machines

*Machines-outils — Lignes directrices et appréciation du risque pour
les machines d'électro-érosion*



Reference number
ISO/TR 17529:2014(E)

© ISO 2014



COPYRIGHT PROTECTED DOCUMENT

© ISO 2014

All rights reserved. Unless otherwise specified, no part of this publication may be reproduced or utilized otherwise in any form or by any means, electronic or mechanical, including photocopying, or posting on the internet or an intranet, without prior written permission. Permission can be requested from either ISO at the address below or ISO's member body in the country of the requester.

ISO copyright office
Case postale 56 • CH-1211 Geneva 20
Tel. + 41 22 749 01 11
Fax + 41 22 749 09 47
E-mail copyright@iso.org
Web www.iso.org

Published in Switzerland

Contents

Page

Foreword	iv
Introduction	v
1 Scope	1
2 Information for the risk assessment	1
2.1 General.....	1
2.2 Hazard identification on EDM equipment and EDM systems during the life phases.....	4
3 Hazard identification	8
4 Risk estimation, evaluation, and reduction	9
4.1 Safety requirements and/or protective measures.....	9
4.2 Protective measures and their verification procedures.....	9
4.3 Information for use.....	9
5 Risk estimation methods	10
5.1 General.....	10
5.2 Risk estimation according to ISO/TR 14121-2.....	10
5.3 Risk estimation according to ISO 13849-1.....	10
5.4 Risk estimation according to ISO 28881.....	11
5.5 Risk parameter.....	14
6 Example of risk assessment	16
Bibliography	23

Foreword

ISO (the International Organization for Standardization) is a worldwide federation of national standards bodies (ISO member bodies). The work of preparing International Standards is normally carried out through ISO technical committees. Each member body interested in a subject for which a technical committee has been established has the right to be represented on that committee. International organizations, governmental and non-governmental, in liaison with ISO, also take part in the work. ISO collaborates closely with the International Electrotechnical Commission (IEC) on all matters of electrotechnical standardization.

The procedures used to develop this document and those intended for its further maintenance are described in the ISO/IEC Directives, Part 1. In particular the different approval criteria needed for the different types of ISO documents should be noted. This document was drafted in accordance with the editorial rules of the ISO/IEC Directives, Part 2 (see www.iso.org/directives).

Attention is drawn to the possibility that some of the elements of this document may be the subject of patent rights. ISO shall not be held responsible for identifying any or all such patent rights. Details of any patent rights identified during the development of the document will be in the Introduction and/or on the ISO list of patent declarations received (see www.iso.org/patents).

Any trade name used in this document is information given for the convenience of users and does not constitute an endorsement.

For an explanation on the meaning of ISO specific terms and expressions related to conformity assessment, as well as information about ISO's adherence to the WTO principles in the Technical Barriers to Trade (TBT) see the following URL: [Foreword — Supplementary information](#).

The committee responsible for this document is ISO/TC 39, *Machine tools*, Subcommittee SC 10, *Safety*.

Introduction

This Technical Report gives additional guidance to the manufacturer to use ISO 28881 by showing a process of the risk assessment based on type A and B standards.

Some documents (e.g. technical reports, guidelines) have already been published but they usually describe about the risk assessment only for machines or for control systems. Manufacturers need guidance that covers both aspects of machines and control systems.

This Technical Report deals with risk assessment for machine and control jointly, i.e. the result of the risk assessment carried out for significant hazards listed in ISO 28881:2013, Table 1, including the results of risk reduction by the protective measures described in ISO 28881:2013, Clauses 5 and 6 and the process of the selection of PL_r as described in ISO 28881:2013, 5.2, are shown.

This Technical Report, based on the following International Standards, is worked out in cooperation with JMTBA (Japanese Machine Tool Builder Association) and ISO/TC 39/SC 10.

- ISO 28881;
- ISO 12100;
- ISO 13849-1;
- ISO/TR 14121-2.

Machine tools — Practical guidance and example of risk assessment on electro-discharge machines

1 Scope

This Technical Report gives practical guidance on conducting risk assessment for machinery in accordance with ISO 12100, ISO 13849-1, and ISO/TR 14121-2. It describes the method, tools, and examples used to generate ISO 28881, to reduce the risk of potential harm on EDM equipment and EDM systems by persons involved in the design, installation, or modification of machinery (e.g. designers, technicians, safety specialists).

2 Information for the risk assessment

2.1 General

The following points should be considered:

- specifications of the EDM equipment and EDM systems (For example of limits of the machinery, see [Table 1](#));
- type of machinery (For examples, see [Figures 1](#) and [2](#));
- hazards and associated hazardous situations;
- estimated risk for each identified hazard and hazardous situations including intended use and any reasonably foreseeable misuse;
- evaluation of the risk and making decisions about the need for risk reduction.

Eliminate or reduce the risk by means of the three-step method in accordance with ISO 12100:2010, 6.1.

- step 1: inherently safe design measures;
- step 2: safeguarding and/or complementary protective measures;
- step 3: information for use.

Table 1 — Example of specifications of the EDM equipment and EDM systems

Items	Wire EDM	Sinker EDM
EDM machine figure	See Figure 1	See Figure 2
Power supply		
Input voltage	200 V a.c., three-phase	200 V a.c., three-phase
Electrical supply capacity	13,5 kVA	13,0 kVA
Compressed air	0,5 MPa to 0,7 MPa Equal to or more than 75 l/min	0,6 MPa
Machine weight	2 000 kg	5 000 kg
Generator		
Type of circuits	Transistor pulse (energy retrieval type)	Transistor pulse
Output voltage	300 V	200 V
Output current	50 A	60 A
Linear axis (X, Y, Z)		
Stroke (mm)	X350 × Y250 × Z220	X300 × Y200 × Z200
Output power	a.c. 0,6 kW	a.c. 1,0 kW
Feeding speed	1 300 mm/min	5 000 mm/min
Z-axis	With brake Without balancer	With brake Without balancer
Rotary axis	Not applicable	C-axis
Output power		a.c. 0,5 kW
Electrode		
Size	Wire diameter: 0,1 to 0,3 [mm]	Not specified
Max. weight	10 kg	50 kg
Automatic tool changer	Not applicable	Applicable
Number of electrodes	1 spool	30 electrodes
Max. weight per electrode	10 kg	10 kg
Workpiece		650 × 450 × 195 mm
Max. size	800 × 600 × 215 mm	650 × 450 mm
Max. weight	500 kg	800 kg
Dielectric fluid		
Material	Water	Oil with flash point more than 60 °C
Container capacity	440 l	350 l
Installation environment		
Temperature	10 °C to 35 °C	10 °C to 35 °C
Relative humidity	35 % to 75 % (no condensation)	35 % to 75 % (no condensation)

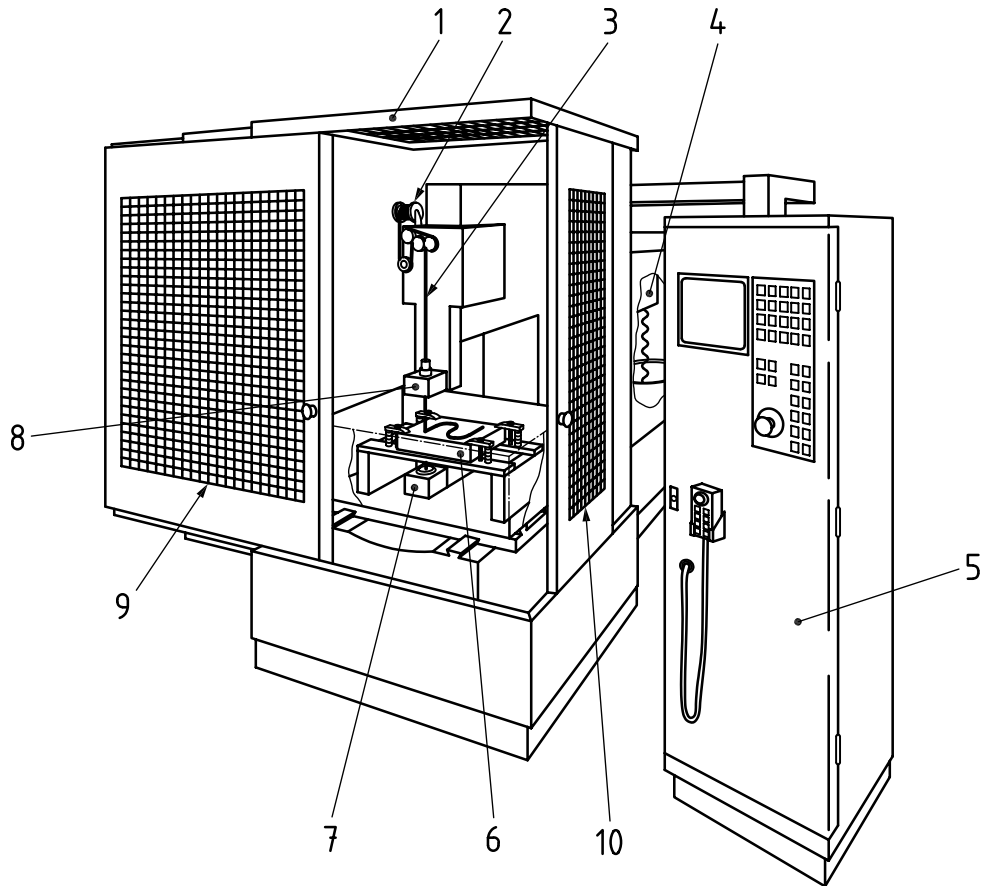

Key

- | | | | |
|---|---------------------------------|----|--------------------|
| 1 | shielded enclosure with door(s) | 6 | workpiece |
| 2 | wire supply spool | 7 | lower wire guide |
| 3 | wire electrode | 8 | upper wire guide |
| 4 | wire evacuation | 9 | interlocking guard |
| 5 | electrical cabinet (generator) | 10 | fix guards |

Figure 1 — Example of wire cutting machine

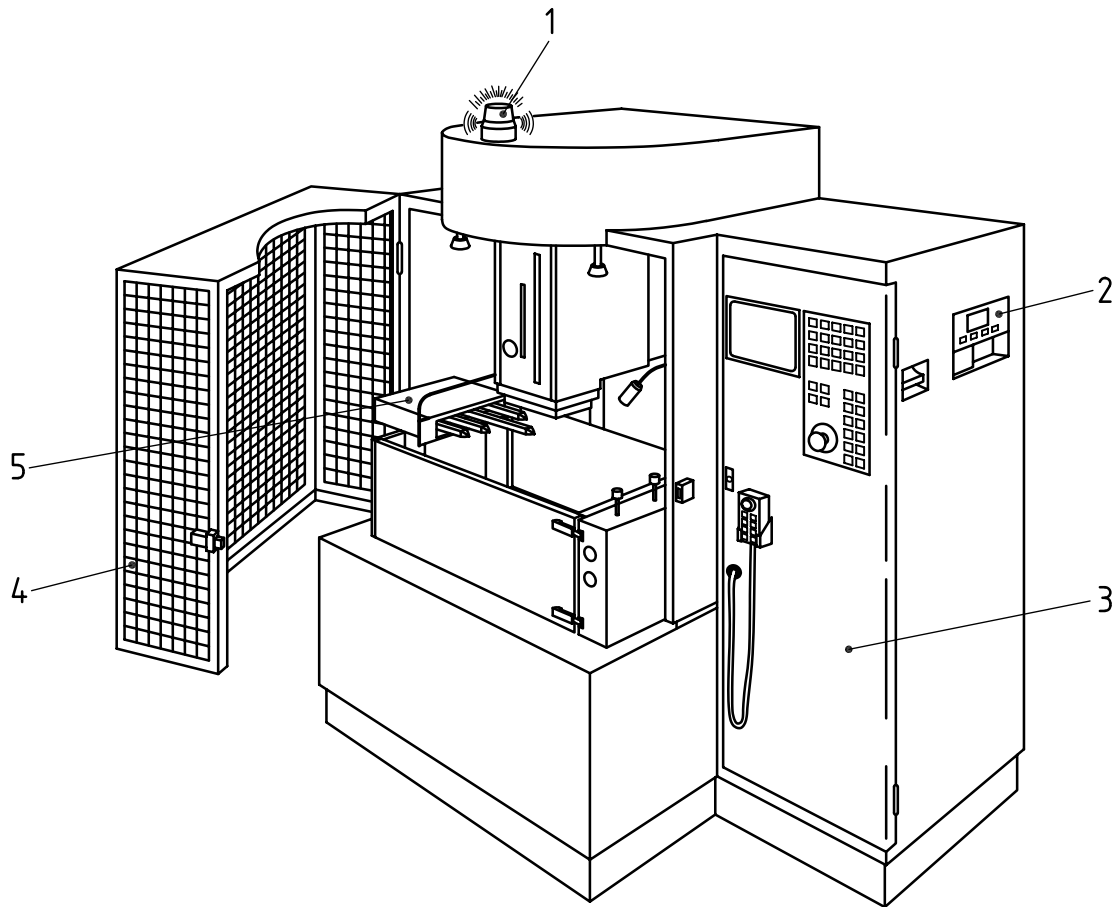

Key

- 1 local fire alarm
- 2 fire detection device
- 3 electrical cabinet (generator)
- 4 interlocking shielded guard
- 5 linear electrode changer

Figure 2 — Example of die sinking machine with linear electrode changer

2.2 Hazard identification on EDM equipment and EDM systems during the life phases

2.2.1 Whole life cycle of the EDM equipment and EDM systems

The phases of the life cycle of the EDM equipment and EDM systems considered to be significant in this example are the following:

- transportation (including in-house transport and movement);
- assembly, installation, and commissioning;
- setting and operation;
- cleaning and maintenance;
- fault finding and troubleshooting;
- removal, dismantling, and disposal.

2.2.2 Space limits

EDM equipment and EDM systems are assumed to be used in the industrial environment of the factory.

EDM equipment and EDM systems are assumed to be used in the environment without direct sunshine, dust, and water splash.

EDM equipment and EDM systems are not assumed to be used in the atmosphere having fire or explosion hazard.

Necessary area for all phases of the life cycle of the EDM equipment and EDM systems (i.e. installation, operation, maintenance, etc.) is assumed to be secured. However, concrete size is not specified here because it does not seem to be reasonable from the objective of this example.

2.2.3 Time limits

This example describes only the aspects of time limits which should be generally determined because it is not reasonable to specify concrete values here from the objective of this example.

- life of the machine;
- interval of inspection;
- interval of parts replacement;
- interval of cleaning and maintenance.

2.2.4 Use limits (intended use and reasonably foreseeable misuse)

Intended use and reasonably foreseeable misuse of the EDM equipment and EDM systems should be considered in each phase of the life cycle.

The EDM is assumed to be used by a person

- who is a trained operator,
- without visual or hearing impairment,
- without restrictions on physical ability of upper or lower limbs, or
- without usage of medical implants liable to be affected by electromagnetic radiation (e.g. pacemaker).

See [Table 2](#) for example of lifecycle and task in automatic, setting, and discharge alignment operation on EDM equipment and EDM systems.

Table 2 — The phases of lifecycle and tasks in automatic, setting, and discharge alignment operation

Task, operator, and reasonably foreseeable misuse			
Automatic operation (machining)	Description	Wire EDM	Sinker EDM
	(1) Automatic workpiece preparation		
	— measuring workpieces (vertical, parallel, edge, etc.)	X	X
	— measuring workpieces (with high voltage)	X	X
	— measuring workpieces (with low voltage)	X	X
	(2) Automatic electrode preparation		
	— connection of wire electrode	X	
	— vertical wire alignment (adjusting by U-axis and V-axis)	X	
	— clamping electrode (with automatic tool changer)		X
	— measuring electrodes (edge, centre, etc.)		X
	(3) Making and verifying machining program		
	— programmed operation without electric discharge power	X	X
	(4) Tasks during processing		
	— starting process	X	X
	— intervention during processing	X	X
	— adjusting flushing pressure	X	
	— adjusting flushing pressure (injection, suction)		X
	— monitoring process condition	X	X
	— adjusting machining conditions	X	X
	— wire reconnection at break point	X	
	(5) Tasks after processing		
	— measuring workpieces (with high voltage)	X	X
	— measuring workpieces (with low voltage)	X	X
	— cutting wire electrode	X	
	(6) Automatic removal of core part		
	— preparation for cutting core part	X	
	— cutting core part	X	
	— removing core part	X	
	Automatic operation is intended to be carried out by		
	— operators with appropriate knowledge and/or experience on the usage of machine and with full understanding of the instructions described in the information for use, and		
	— persons under the supervision of such operators.		
	Reasonably foreseeable misuses in the automatic operation are		
	— opening guards during programmed operation,		
	— starting programmed operation with guard open, and		
	— processing with inappropriate fluid level in work tank.		

Table 2 (continued)

Task, operator, and reasonably foreseeable misuse			
Setting operation	Description	Wire EDM	Sinker EDM
	(1) Confirmation of workpiece	X	X
	(2) Setting of workpiece		
	— workpiece setting (manual)	X	X
	— axis feeding (manual)	X	X
	— measuring workpieces (vertical, parallel, edge, etc.)	X	X
	— measuring workpieces (with low voltage)	X	X
	(3) Setting of electrode		
	— attaching wire electrode (spool)	X	
	— installing wire electrode to rollers and connecting it	X	
	— clamping electrode		X
	— transporting wire electrode	X	
	— adjusting location of metal parts for power supply (energizing parts, in other words)	X	
	— wire tension setting	X	
	— vertical wire alignment (adjusting by U-axis and V-axis)	X	
	— adjusting inclination of electrode		X
	— measuring electrode (in case of EDM drilling, measuring residual electrode length)		X
	— correcting straightness of small tubular electrode (with spindle rotation of 1 000 min ⁻¹)		X
	(4) Other setting		
	— nozzle distance, clearance	X	
	— direction of flushing nozzle		X
	— setting of flushing pressure	X	X
	— program, machining conditions	X	X
	— filling fluid, adjusting fluid level	X	X
	— opening and closing or vertical movement of work tank	X	X
	(5) Making and verifying machining program		
	— programmed operation without electric discharge power	X	X
	(6) Tasks during intervention or after processing		
	— wire reconnection at break point	X	
	— opening and closing, or vertical movement of work tank	X	X
	— axis feeding	X	X
	— measuring workpiece (with low voltage)	X	
	— measuring workpiece (with low voltage) (in case of EDM drilling, confirming piercing through workpiece)		X
	— cutting wire electrode (by scissors, etc.)	X	

Table 2 (continued)

Task, operator, and reasonably foreseeable misuse				
Setting operation (continued)	Description	Wire EDM	Sinker EDM	
	— cleaning workpiece and work tank after processing (by fluid ejection)	X	X	
	(7) Handling of core part			
	— preparation for cutting core part	X		
	— removing core part	X		
	— measuring workpiece (with low voltage)	X		
	— taking out workpiece	X	X	
	(8) Electrode change			
	— removing wire spool	X		
	— removing electrode		X	
	Setting operation is intended to be carried out by — trained and/or qualified operators with appropriate knowledge and/or experience on the usage of machine and with full understanding of the instructions described in the information for use.			
	Reasonably foreseeable misuses in the setting operation are — processing flammable materials, — starting programmed operation with guard open, and — switching on electric machining power with guard open.			
Discharge alignment operation	Description	Wire EDM	Sinker EDM	
	(1) Exhaust air extraction adjustment	X	X	
	(2) Dielectric fluid flushing adjustment	X	X	
	(3) Visual machining inspection	X	X	
	(4) Electrode alignment	X	X	
	Discharge alignment operation is intended to be carried out by — trained and/or qualified operators with appropriate knowledge and/or experience on the usage of machine and with full understanding of the instructions described in the information for use.			
Reasonably foreseeable misuses in the discharge alignment operation are — processing flammable materials, — starting programmed operation with guard open, and — forgetting to switch off electric machining power after discharge alignment operation.				

3 Hazard identification

Particular attention is paid to hazards dealing with (see ISO 28881:2013, Clause 4)

- electrical hazards (electrode voltage),
- flammable dielectric fluid (level, temperature, and fire detection),
- hazardous substances (waste disposal, filters, used dielectric fluid, electrodes, and sludge), and
- electromagnetic emissions (radiated and conducted), see IEC 61000-6-2:2005 for EMC for immunity and IEC 61000-6-4:2011 for EMC for emission.

The list of significant hazards and major sources of these hazards associated with electro-discharge machines are given in ISO 28881:2013, Table 1.

4 Risk estimation, evaluation, and reduction

4.1 Safety requirements and/or protective measures

EDM equipment and EDM systems should all comply with the safety requirements and/or protective measures and be verified in accordance with ISO 28881:2013, Clause 5. In addition, the equipment and systems should be designed in accordance with the principles of ISO 12100 for relevant, but not significant, hazards, which are not dealt with by the above mentioned International Standards. Analysis of failure of machine components, including failure in the control system(s), is part of the risk assessment and guidance on this subject is given in ISO 13849-1.

Safety functions of control systems should be implemented using safety-related parts designed, constructed and applied in accordance with ISO 13849-1. Safety-related parts of control systems implementing the safety functions should meet the requirements for the performance level and category of ISO 13849-1, as listed in ISO 28881:2013, Table 2.

General safety requirements and/or protective measures for EDM equipment and EDM systems are given in ISO 28881:2013, Table 2 and ISO 28881:2013, Table 3.

4.2 Protective measures and their verification procedures

Safety requirements and/or protective measures as needed for EDM equipment and EDM systems to prevent hazards identified in hazard identification, should be taken and verified using the procedures indicated in the verification column (see ISO 28881:2013, Table 3), with the following abbreviated phrases:

- by testing (e.g. functional or practical check);
- by measurement;
- by calculation;
- by visual inspection, if testing and calculation are not adequate;
- by analysis of documentation (e.g. circuit or functional diagram, information for use).

4.3 Information for use

Information for use refers to communication links, such as texts, words, signs, signals, symbols, or diagrams, which are used separately or in combination, to convey information to the user and which should be in accordance with ISO 12100:2010, 6.4.

The information for use should document hazards which can occur during the life of the machine to both the operator and other persons who have access to the danger zone(s) for conditions of intended use, including reasonably foreseeable misuse of the machine (see ISO 12100:2010, 3.24) for both spark erosion with automatic mode and operations requiring intervention (e.g. setting, maintenance, and repair).

The instruction handbook should provide all necessary information regarding transport, installation, operation, setting, maintenance, cleaning, and disposal of the EDM equipment and EDM system, in accordance with ISO 12100:2010, 6.4.5.

Information for use, such as

- marking, signs, and written warnings, and

- instruction handbook (special recommendation, general safety information, power specifications, compressed air specifications, flammable dielectric fluid, hazardous substances, electromagnetic emissions, special recommendations for EDM operation and noise) are given in ISO 28881:2013, Clause 6.

5 Risk estimation methods

5.1 General

Some kinds of risk graph methods are used in this technical report. Sub-clauses shown in this clause explain how to use the risk graph methods. 5.5 explains the risk parameters used in 5.2, 5.3, and 5.4.

5.2 Risk estimation according to ISO/TR 14121-2

This risk graph method (see Figure 3) is derived from ISO/TR 14121-2:2012, 6.3.2. This risk graph method shows how to estimate both initial risk and residual risk of the hazards on machine. The result of this estimation is used to evaluate if the residual risk is permissible or not. If the residual risk is not permissible, risk assessment cycle has to be implemented again until the residual risk is permitted.

This risk graph method uses risk parameters S, F, O, and A, then this classify the risk to six levels. See ISO/TR 14121-2 for more information.

This method should be used for general risk assessment.

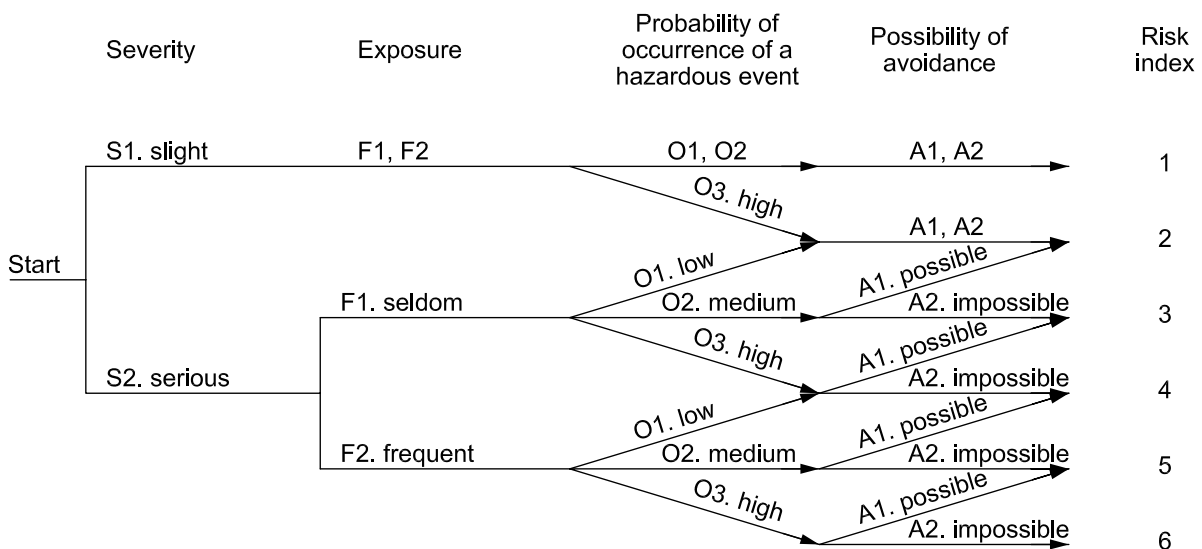
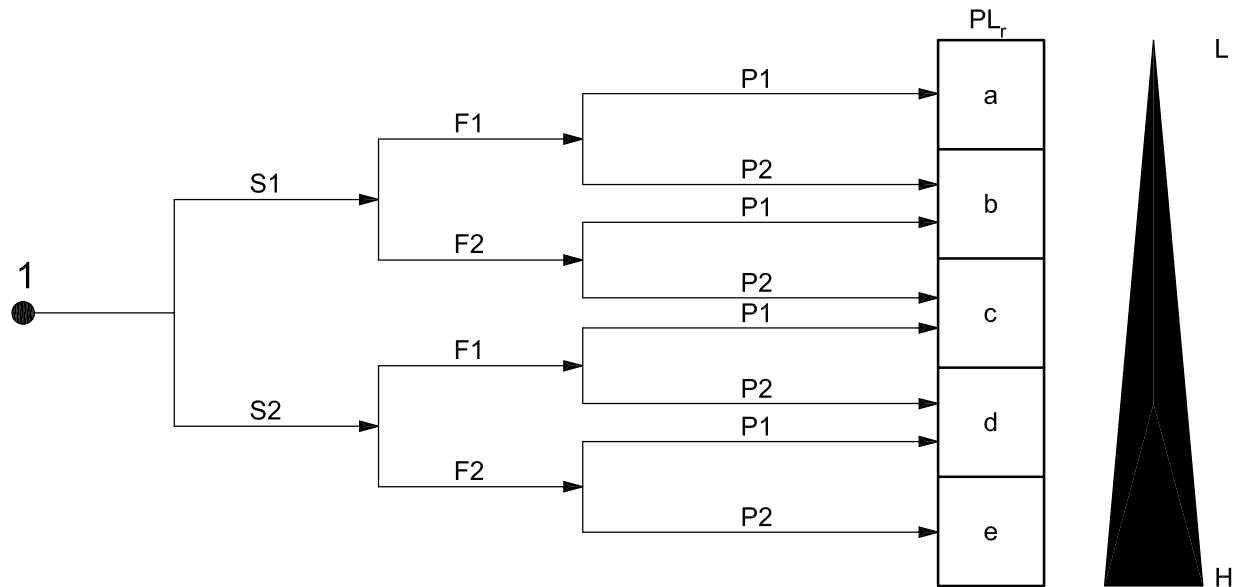

Figure 3 — Example of risk graph for risk estimation(ISO/TR 14121-2:2012, Figure 3)

5.3 Risk estimation according to ISO 13849-1

This risk graph method (see Figure 4) is derived from ISO 13849-1:2006, Annex A. This risk graph method shows how to estimate risk to determine required performance level according to ISO 13849-1. The result of this risk estimation is not used to evaluate residual risk, but it is used only to determine required performance level for safety related parts of control system. This risk graph method uses risk parameters S, F, and P and classifies PL_r to five levels. See ISO 13849-1:2006, Annex A for more information.

This method should be used for risk assessments which involve control systems.



Key

- 1 starting point for evaluation of safety function's contribution to risk reduction
- L low contribution to risk reduction
- H high contribution to risk reduction
- PL_r required performance level

Risk parameters

- S severity of injury
- S1 slight (normally reversible injury)
- S2 serious (normally irreversible injury or death)
- F frequency and/or exposure to hazard
- F1 seldom-to-less-often and/or exposure time is short
- F2 frequent-to-continuous and/or exposure time is long
- P possibility of avoiding hazard or limiting harm
- P1 possible under specific conditions
- P2 scarcely possible

NOTE The risk parameter of "possibility of avoidance or reduction of harm" is expressed as "P" in ISO 13849-1:2006, Figure A.1, but "A" is used in ISO/TR 14121-2:2012, Figure A.3. They have the same meaning essentially; therefore "A" is adopted in this Technical Report.

Figure 4 — Risk graph for determining required PL_r for safety function(ISO 13849-1:2006, Figure A.1)

5.4 Risk estimation according to ISO 28881

The [Figures 5](#) and [6](#) show the equivalent method in the risk graph method described in [5.2](#) and [5.3](#) respectively. This information may be useful if risk matrix, which is used for risk estimation with combination severity of harm and probability of occurrence, already exists.

5.4.1 Estimate frequency and impact of possible hazards

First step: The manufacturer should check if foreseeable hazards happened in the past with the earlier produced EDM equipment and EDM system, and identify the frequency (ranging from unlikely to often) as well as the impact of hazards (from negligible injury to danger of life). Then, estimate the possible hazards on the equipment to be designed and complete the file accordingly. If the result of this estimation is located in the dark grey area, such hazards are not acceptable and a responsible person should be put in charge to review the technical solution according to ISO 12100. The reviewed solution should be checked again to verify that the expected risk minimization enters below in the dark grey area.

Reference to ISO/TR 14121-2		Impact of possible hazards				
		S1		S2		
Probability of occurrence of harm (experience)		Negligible injury	Minor injury	Relevant injury	Permanent injury	Danger of life
F2-O3-A2	Often					
F2-O2-A2 = F2-O3-A1	Casually					
F2-O1-A2 = F1-O3-A2 = F2-O2-A1	Seldom					
F2-O1-A1 = F1-O3-A1 = F1-O2-A2	Exceptional					
F1-O2-A1 = F1-O1-A2 = F1-O1-A1	Unlikely					

Figure 5 — Estimate frequency and impact of possible hazards(ISO 28881:2013, Figure D.1)

5.4.2 Identify required performance level (PL_r) to prevent possible hazards

Second step: Make sure that all identified risks are below the dark grey areas; identify the required performance level from often (i.e. negligible injury) to unlikely (i.e. danger of life) for each channel, as indicated in the light grey area.

Reference to ISO 13849-1:2006	Probability of occurrence of harm (experience)	Negligible injury	Minor injury	Relevant injury	Permanent injury	Danger of life
S1-F1-A1	Often	PL _r =a				
S1-F1-A2 =S1-F2-A1	Casualy		PL _r =b			
S1-F2-A2 =S2-F1-A1	Seldom			PL _r =c		
S2-F1-A2 =S2-F2-A1	Exceptional				PL _r =d	
S2-F2-A2	Unlikely					PL _r =e

Figure 6 — Identify required performance level (PL_r) to prevent possible hazards(ISO 28881:2013, Figure D.2)

5.4.3 Define mean time to dangerous failure (MTTF_d) and diagnostic coverage (DC_{avg})

Third step: Define the necessary mean time to dangerous failure (MTTF_d) of the available components, as well as the diagnostic coverage (DC_{avg}) of the control system, to identify the required performance level (PL_r) and the category, if necessary, as shown in of ISO 13849-1:2006, Figure 5.

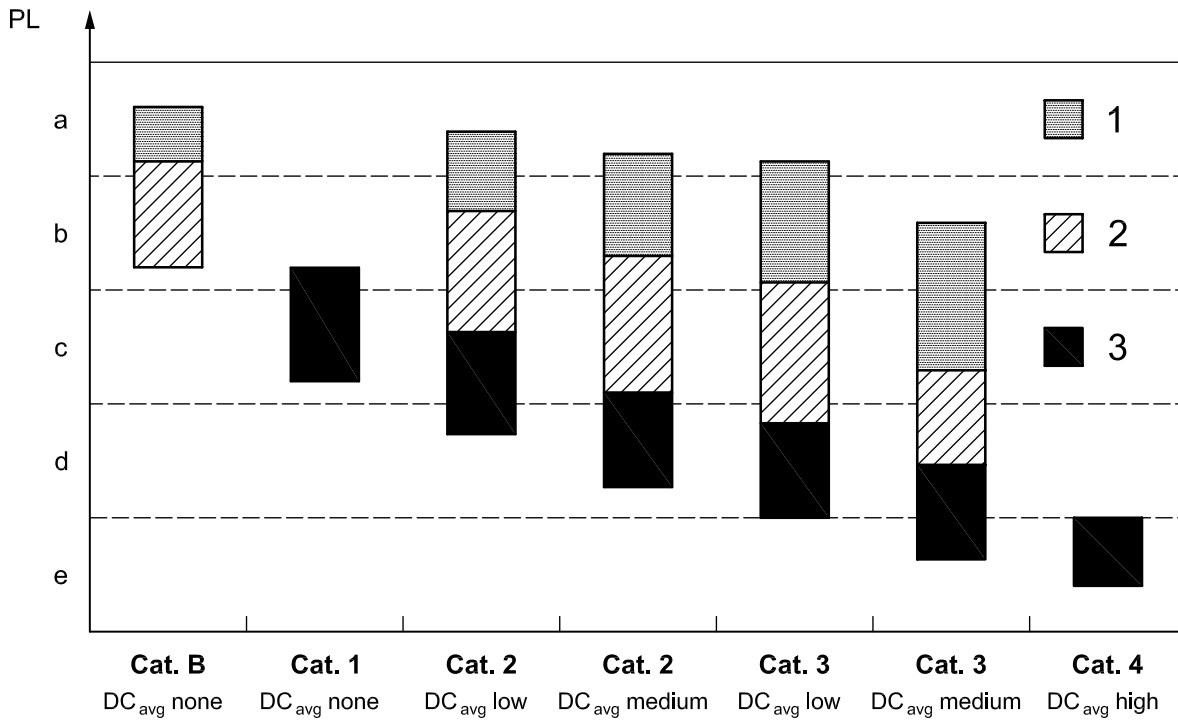

Key

- PL performance level
- 1 MTTF_d of each channel = low
- 2 MTTF_d of each channel = medium
- 3 MTTF_d of each channel = high

Figure 7 — Define mean time to dangerous failure (MTTF_d) and diagnostic coverage (DC_{avg}) (ISO 28881:2013, Figure D.3)

5.5 Risk parameter

Risk parameters used in Table 3 are as follows.

NOTE These abbreviations are based on the risk parameters used in ISO/TR 14121-2:2012, Figure A.3 and in ISO 13849-1:2006, Figure A.1. Although there are slight differences of explanations between ISO/TR 14121-2 and ISO 13849-1, it could be considered that the risk parameters are essentially the same in meaning. In this example, more concrete interpretation is added.

S: Severity of harm

S1: slight injury (usually reversible), for example, scratches, laceration, bruising, light wound requiring first aid

S2: serious injury (usually irreversible, including fatality), for example, broken or torn-out or crushed limbs, fractures, serious injuries requiring stitches, major musculoskeletal troubles (MST), fatalities

F: Frequency and/or duration of exposure to hazard

F1: seldom or short duration, i.e.

- the frequency of access to the hazard zone is less than once per 1 h, or
- time spent in the hazard zone is less than 15 min per one time.

F2: frequent or long duration, i.e.

- the frequency of access to the hazard zone is once or more per 1 h, or
- time spent in the hazard zone is equal to or more than 15 min per one time.

In this regard, taking account of “nature of access” [see ISO 12100:2010, 5.5.2.3.1 b)], F1 can be chosen in the case where the hazard is moving parts of the machine and the access to the hazard zone as “intended use” is foreseen only while the moving parts are stopping.

O: Probability of occurrence of hazardous event

O1: mature technology, proven, and recognized in safety application, robustness:

- protective measures are not depending on the extent of training and/or knowledge level of operators;
- performance level of implemented safety function meets PL_r .

O2: technical failure observed in last 2 years:

- inappropriate human action by a well-trained person aware of the risks and having more than 6 months experience on the work station;
- the operator knows well the hazards, hazardous situation and/or sign of hazardous and urgent event.

O3: technical failure regularly observed:

- inappropriate human action by an untrained person having less than 6 months experience on the work station;
- similar accident observed in the factory in the preceding 10 years.

A: Possibility of avoidance or reduction of harm (“P” in ISO 13849-1)

The risk parameter of “possibility of avoidance or reduction of harm” is expressed as “P” in ISO 13849-1:2006, Figure A.1, but “A” is used in ISO/TR 14121-2:2012, Figure 3. They have the same meaning essentially; therefore, “A” is adopted in this Technical Report.

A1: possible under some conditions:

- if parts move at speed less than 0.25 m/s (15 m/min);
- depending on particular conditions (temperature, noise, ergonomics, etc.).

A2: impossible

It is not always rational to apply the above parameters to estimating risks associated with hygienic or ergonomic hazards, nor fire/explosion; therefore, the following assumptions are applied.

- Hygienic and ergonomic hazards

Hygiene risks mainly depend on the type of toxic (hazardous properties), the concentration and the duration of exposure. Similarly, ergonomic risks are estimated considering factors such as repetitiveness, force, posture, movements, duration, and time to recover, which might also be distributed under the parameters of severity and exposure.

Thus, for these types of risk, it seems that the estimation of the probability of occurrence of a hazardous event and the possibility of avoidance has little sense.

For this reason, in this example, only severity and exposure are considered, and for the probability of occurrence of a hazardous event and the possibility of avoidance, the most conservative value is taken/assumed.

— Fire/explosion

The risk of fire depends on the presence of flammable substances or materials, the oxygen and the ignition sources. The parameters of severity, exposure, and probability of the hazardous event can be associated respectively to the size and strength of the potential fire, the duration of the hazardous situation and the probability of the machine catching fire. Where there is a possibility of avoidance, it appears difficult to make a real estimation, so the most conservative value is assumed.

6 Example of risk assessment

[Table 3](#) shows one example of risk assessment for hazard caused by electrical discharged power, implemented for automatic mode, setting mode, and discharge alignment mode.

NOTE The following example is an extract of a complete risk assessment and, therefore, the numbers indicated at the leftmost column (e.g. 73, 123, etc.) are not sequential and continuous.

Table 3 — Example of risk assessment for EDM equipment and EDM systems electrical discharge power

No.	Task	Hazard zone	Hazard ^a	Hazardous situation	Hazardous event ^b	Risk estimation (initial)		Risk reduction measures ^a	Cat./PL _r	Risk estimation (after)		Risk evaluation ^c	Note
						SFOA, RI	SFOA, RI						
3. Mode of operation/electrical discharge power													
3.1 Automatic mode/electrical discharge power													
73	Machining (automatic mode)	In work area	2.1 Live parts (electrode, workpiece, wire/wire-path)	Access to hazardous area in operation	Direct contact with live parts (electrode, workpiece, wire/wire-path)	2232, 6	A1.1.2 Where hazardous situations cannot be prevented, fixed guards (or movable guard) shall be used where no access to danger zones is necessary during intended use.	—/—	2132, 4	74	Movable guards without interlocking function are also evaluated in this line. Initial risk S2: Irreversible injury including death might be caused by direct contact. F2: Access to hazardous area is foreseen. O3: Operators may contact with live parts inadvertently. A2: Low possibility to avoid electrical shock. After risk reduction F1: Access to hazardous area is restrained by fixed guards (or movable guard). After risk reduction O1: Contact with live parts is prevented by interlocking guards. A1: Electric machining power is cut off by interlocking function of guards. PL _r should be determined according to ISO 13849-1:2006, Annex A, but it has been agreed through making process of ISO 28881 that PL _r = c is considered as adequate. It has been agreed through making process of ISO 28881 that interlocking function of guards needs to have higher safety performance and that Cat. 3 is assigned.		
74						2132, 4	B2.1.4 The work area on EDM equipment and EDM systems, where electrical energy is used as a working tool, shall be protected with interlocking guards, to prevent accidental or inadvertent contact.	3/c	2111, 2	End			
75							B2.1.6 On EDM equipment and EDM systems where hazardous electric discharge power is used for position pick-up by contact sensing, such operations shall only be possible with interlocking guards closed, with the exception of the discharge alignment mode.						

Table 3 — (continued)

No.	Task	Hazard zone	Hazard ^a	Hazardous situation	Hazardous event ^b	Risk estimation (initial)	Risk reduction by protective measures ^a	Cat./PL _r	Risk estimation (after)	Risk evaluation ^c	Note
3.2 Setting mode/electrical discharge power											
123	Setting	In work area	2.1 Live parts (electrode, workpiece, wire/wire-path)	Contact sensing of tool and workpiece	Direct contact with live parts (electrode, workpiece, wire/wire-path)	2132, 4	5.3.2.2 In setting mode, the electric discharge power of parts, which can be touched, shall be limited to ≤25 V a.c. or ≤60 V d.c. (using a safety source in accordance with IEC 61558-1).	—/—	—, —	End	Initial risk S2: Irreversible injury including death might be caused by direct contact. F1: Touching live parts intentionally is not assumed. O3: Operators may contact with live parts inadvertently. A2: Low possibility to avoid electrical shock. After risk reduction The hazard is eliminated by using a safety source for that voltage.
3.3 Discharge alignment mode/electrical discharge power											
125	Discharge alignment operation — exhaust air extraction — dielectric fluid flushing — adjustment — visual machining inspection — vertical wire alignment (with high voltage)	In work area	2.1 Live parts (electrode, workpiece, wire/wire-path)	During automatic mode, with hazardous electric discharge power and guards open	Direct contact with live parts (electrode, workpiece, wire/wire-path)	2132, 4	5.3.2.3 a) — set the key switch to discharge alignment mode; — open the guards to operate the discharge alignment operations.	—/c	2132, 4	126	Initial risk S2: Irreversible injury including death might be caused by voltage of 60 V d.c. to 350 V d.c. or 25 V a.c. to 100 V a.c. F1: It is assumed that exposure is less than 15 min per one time. O3: Operators work near live parts. A2: Low possibility to avoid electrical shock. After risk reduction PL _r should be determined according to ISO 13849-1:2006, Annex A, but it has been agreed through making process of ISO 28881 that PL _r = c is considered as adequate in No. 125 to 127.

Table 3 — (continued)

No.	Task	Hazard zone	Hazard ^a	Hazardous situation	Hazardous event ^b	Risk estimation (initial)	Risk reduction by protective measures ^a	Cat./PL _r	Risk estimation (after)	Risk evaluation ^c	Note
3.3 Discharge alignment mode/electrical discharge power											
126	Discharge alignment operation	In work area	2.1 Live parts (electrode, workpiece, wire/wire-path)	During setting mode, with hazardous electric discharge power and guards open	Direct contact with live parts (electrode, workpiece, wire/wire-path)	2132, 4	5.3.2.3 a) — press the button of the one-hand operation enabling device and keep it pressed during discharge alignment mode.	3/c	2122, 3	127	After risk reduction O2: Enabling device contributes to reduce probability of contact with live parts. It has been agreed through making process of ISO 28881 that enabling device function needs to have higher safety performance and that Cat. 3 is assigned.
127						2122, 3	5.3.2.3 a) — activate the maximum time of 2 min; — after a maximum of 2 min, the discharge alignment mode shall be automatically stopped. To continue the stopped automatic operation, close the guards, turn the key switch back to automatic mode and press the start button again.	—/c	2112, 2	128	After risk reduction O1: 2 min limit function contributes to reduce probability of inadvertent contact with live parts.
128						2112, 2	5.3.2.3 a) — activate visual and audible alarm signal; — after a maximum of 2 min, the visual and audible alarm signal shall be deactivated.	—/—	2112, 2	133	After risk reduction O1: Risk parameters are not improved because they are rough classifications. However protection measure for safety, visual and audible alarm signal contributes to reduce probability of inadvertent contact with live parts.

Table 3 — (continued)

No.	Task	Hazard zone	Hazard ^a	Hazardous situation	Hazardous event ^b	Risk estimation (initial)	Risk reduction by protective measures ^a	Cat./PL _r	Risk estimation (after)	Risk evaluation ^c	Note
3.3 Discharge alignment mode/electrical discharge power											
129	Discharge alignment operation	In work area	2.1 Live parts (electrode, workpiece, wire/wire-path)	During setting mode, with hazardous electric discharge power and guards open	Direct contact with live parts (electrode, workpiece, wire/wire-path)	2132, 4	5.3.2.3 b) — set the key switch to discharge alignment mode; — perform the discharge alignment operation by tilting or feeding.	—/c	2132, 4	130	Initial risk S2: Irreversible injury including death might be caused by voltage of 60 V d.c. to 350 V d.c. or 25 V a.c. to 100 V a.c. F1: It is assumed that exposure is less than 15 min per one time. O3: Operators work near live parts. A2: Low possibility to avoid electrical shock. After risk reduction PL _r should be determined according to ISO 13849-1:2006, Annex A, but it has been agreed through making process of ISO 28881 that PL _r = c is considered as adequate in No. 129 to 131.
130						2132, 4	5.3.2.3 b) — press the button of the one-hand operation enabling device and keep it pressed during discharge alignment mode.	3/c	2122, 3	131	After risk reduction O2: Enabling device contributes to reduce probability of contact with live parts. It has been agreed through making process of ISO 28881 that enabling device function needs to have higher safety performance and that Cat. 3 is assigned.
131						2122, 3	5.3.2.3 b) — activate the maximum time of 2 min; — after a maximum 2 min, the discharge alignment mode shall be automatically stopped, and all operations shall be ignored by the control system.	—/c	2112, 2	132	After risk reduction O1: 2 min limit function contributes to reduce probability of inadvertent contact with live parts.

Table 3 — (continued)

No.	Task	Hazard zone	Hazard ^a	Hazardous situation	Hazardous event ^b	Risk estimation (initial)	Risk reduction by protective measures ^a	Cat./PL _r	Risk estimation (after)	Risk evaluation ^c	Note
3.3 Discharge alignment mode/electrical discharge power											
132	Discharge alignment operation	In work area	2.1 Live parts (electrode, workpiece, wire/wire-path)	During setting mode, with hazardous electric discharge power and guards open	Direct contact with live parts (electrode, workpiece, wire/wire-path)	2112, 2	5.3.2.3 b) — activate visual and audible alarm signal; — after a maximum of 2 min, the visual and audible alarm signal shall be deactivated.	—/—	2112, 2	133	After risk reduction O1: Risk parameters are not improved because they are rough classifications. However, protection measure for safety, visual, and audible alarm signal contributes to reduce probability of inadvertent contact with live parts.
133							6.3.2.2 a) 8) General safety information shall include instructions for use of an enabling device or other equally safe protection device for one-hand operation to prevent the operator from coming into direct contact with hazardous electric discharge power in discharge alignment mode.	—/—	2112, 2	135	After risk reduction O1: The instructions contribute to reduce probability of inadvertent contact with live parts.
134							6.3.2.2 b) Instructions for use of personal protective equipment shall include 1) instructions for the use of appropriate insulated industrial gloves, and 2) instructions for the use of appropriate footwear.				

Table 3 — (continued)

No.	Task	Hazard zone	Hazard ^a	Hazardous situation	Hazardous event ^b	Risk estimation (initial)	Risk reduction by protective measures ^a	Cat./PL _r	Risk estimation (after)	Risk evaluation ^c	Note
3.3 Discharge alignment mode/electrical discharge power											
135	Discharge alignment operation	In work area	2.1 Live parts (electrode, workpiece, wire/wire-path)	During setting mode, with hazardous electric discharge power and guards open	Direct contact with live parts (electrode, workpiece, wire/wire-path)	2112, 2	5.3.2.3 In the information for use, provide information about the necessity of the operator to have knowledge and instruction on the specific electrical hazard; for this reason, a relevant written authorization for working with live electrical parts shall be available.	—/—	2112, 2	End	After risk reduction Information for use does not have so much effect as risk parameters are improved, but it contributes to risk reduction.
136							6.3.2.2 a) 10) General safety information shall include: instructions to have written authorization for the use of EDM equipment and EDM systems.				

^a Numbers in "Hazard" column are derived from ISO 28881:2013, Table 1 and numbers/alphabets in "Risk reduction" column are derived from subclause numbers of ISO 28881 or classification numbers in ISO 28881:2013, Table 3.

^b Hazardous events in setting or discharge alignment mode which occur also in automatic mode are listed only in automatic mode for simple description of this risk assessment.

^c Each number in "Risk evaluation" column indicates the line number of risk assessment and risk reduction in case that further risk reduction is required. "End" means that the objective of risk reduction is achieved.

Bibliography

- [1] ISO 3746, *Acoustics — Determination of sound power levels and sound energy levels of noise sources using sound pressure — Survey method using an enveloping measurement surface over a reflecting plane*
- [2] ISO 4413, *Hydraulic fluid power — General rules and safety requirements for systems and their components*
- [3] ISO 4414, *Pneumatic fluid power — General rules and safety requirements for systems and their components*
- [4] ISO 4871, *Acoustics — Declaration and verification of noise emission values of machinery and equipment*
- [5] ISO 11202, *Acoustics — Noise emitted by machinery and equipment — Determination of emission sound pressure levels at a work station and at other specified positions applying approximate environmental corrections*
- [6] ISO/TR 11688-1, *Acoustics — Recommended practice for the design of low-noise machinery and equipment — Part 1: Planning*
- [7] ISO 12100:2010, *Safety of machinery — General principles for design — Risk assessment and risk reduction*
- [8] ISO 13849-1:2006, *Safety of machinery — Safety-related parts of control systems — Part 1: General principles for design*
- [9] ISO 13849-2, *Safety of machinery — Safety-related parts of control systems — Part 2: Validation*
- [10] ISO 13850, *Safety of machinery — Emergency stop — Principles for design*
- [11] ISO 13855, *Safety of machinery — Positioning of safeguards with respect to the approach speeds of parts of the human body*
- [12] ISO 13857, *Safety of machinery — Safety distances to prevent hazard zones being reached by upper and lower limbs*
- [13] ISO 14118, *Safety of machinery — Prevention of unexpected start-up*
- [14] ISO 14122-1, *Safety of machinery — Permanent means of access to machinery — Part 1: Choice of fixed means of access between two levels*
- [15] ISO 14122-2, *Safety of machinery — Permanent means of access to machinery — Part 2: Working platforms and walkways*
- [16] ISO 14122-3, *Safety of machinery — Permanent means of access to machinery — Part 3: Stairs, stepladders and guard-rails*
- [17] ISO 28881:2013, *Machine tools — Safety — Electro-discharge machines*
- [18] IEC 60204-1:2009, *Safety of machinery — Electrical equipment of machines — Part 1: General requirements*
- [19] IEC 60529:2001, *Degrees of protection provided by enclosures (IP code)*
- [20] IEC 61000-6-2:2005, *Electromagnetic compatibility (EMC) — Part 6-2: Generic standards — Immunity for industrial environments*
- [21] IEC 61000-6-4:2011, *Electromagnetic compatibility (EMC) — Part 6-4: Generic standards — Emission standard for industrial environments*

- [22] IEC 61310-1:2007, *Safety of machinery — Indication, marking and actuation — Part 1: Requirements for visual, acoustic and tactile signals*
- [23] IEC 61310-2:2007, *Safety of machinery — Indication, marking and actuation — Part 2: Requirements for marking*
- [24] IEC 61558-1:2009, *Safety of power transformers, power supplies, reactors and similar products — Part 1: General requirements and tests*
- [25] IEC 61800-5-2:2007, *Adjustable speed electrical power drive systems — Part 5-2: Safety requirements — Functional*
- [26] EN 2:1992, *Classification of fires*
- [27] EN 54-1:2011, *Fire detection and fire alarm systems — Part 1: Introduction*
- [28] EN 349+A1:2008, *Safety of machinery — Minimum gaps to avoid crushing of parts of the human body*
- [29] EN 614-1+A1:2009, *Safety of machinery — Ergonomic design principles — Part 1: Terminology and general principles*
- [30] EN 614-2+A1:2008, *Safety of machinery — Ergonomic design principles — Part 2: Interactions between the design of machinery and work tasks*
- [31] EN 626-1+A1:2008, *Safety of machinery — Reduction of risks to health from hazardous substances emitted by machinery — Part 1: Principles and specifications for machinery manufacturers*
- [32] EN 953+A1:2009, *Safety of machinery — Guards — General requirements for the design and construction of fixed and movable guards*
- [33] EN 1037+A1:2008, *Safety of machinery — Prevention of unexpected start-up*
- [34] EN 1088+A2:2008, *Safety of machinery — Interlocking devices associated with guards — Principles for design and selection*
- [35] EN 12198-1+A1:2008, *Safety of machinery — Assessment and reduction of risks arising from radiation emitted by machinery — Part 1: General Principles*
- [36] EN 12198-2+A1:2008, *Safety of machinery — Assessment and reduction of risks arising from radiation emitted by machinery — Part 2: Radiation emission measuring procedures*
- [37] EN 12198-3+A1:2008, *Safety of machinery — Assessment and reduction of risks arising from radiation emitted by machinery — Part 3: Reduction of radiation by attenuation or screening*
- [38] EN 62226-1:2005, *Exposure to electric or magnetic fields in the low and intermediate frequency range — Methods for calculating the current density and internal electric field induced in the human body — Part 1: General*
- [39] EN 62226-2-1:2005, *Exposure to electric or magnetic fields in the low and intermediate frequency range — Methods for calculating the current density and internal electric field induced in the human body — Part 2-1: Exposure to magnetic fields — 2D models*
- [40] EN 62226-3-1:2007, *Exposure to electric or magnetic fields in the low and intermediate frequency range — Methods for calculating the current density and internal electric field induced in the human body — Part 3-1: Exposure to electric fields — Analytical and 2D numerical models*
- [41] EN 62311:2008, *Assessment of electronic and electrical equipment related to human exposure restriction for electromagnetic field (0 Hz – 300 GHz)*
- [42] CISPR 11:2008, *Industrial, scientific and medical equipment — Radio-frequency disturbance characteristics — Limits and methods of measurement*

British Standards Institution (BSI)

BSI is the national body responsible for preparing British Standards and other standards-related publications, information and services.

BSI is incorporated by Royal Charter. British Standards and other standardization products are published by BSI Standards Limited.

About us

We bring together business, industry, government, consumers, innovators and others to shape their combined experience and expertise into standards-based solutions.

The knowledge embodied in our standards has been carefully assembled in a dependable format and refined through our open consultation process. Organizations of all sizes and across all sectors choose standards to help them achieve their goals.

Information on standards

We can provide you with the knowledge that your organization needs to succeed. Find out more about British Standards by visiting our website at bsigroup.com/standards or contacting our Customer Services team or Knowledge Centre.

Buying standards

You can buy and download PDF versions of BSI publications, including British and adopted European and international standards, through our website at bsigroup.com/shop, where hard copies can also be purchased.

If you need international and foreign standards from other Standards Development Organizations, hard copies can be ordered from our Customer Services team.

Subscriptions

Our range of subscription services are designed to make using standards easier for you. For further information on our subscription products go to bsigroup.com/subscriptions.

With **British Standards Online (BSOL)** you'll have instant access to over 55,000 British and adopted European and international standards from your desktop. It's available 24/7 and is refreshed daily so you'll always be up to date.

You can keep in touch with standards developments and receive substantial discounts on the purchase price of standards, both in single copy and subscription format, by becoming a **BSI Subscribing Member**.

PLUS is an updating service exclusive to BSI Subscribing Members. You will automatically receive the latest hard copy of your standards when they're revised or replaced.

To find out more about becoming a BSI Subscribing Member and the benefits of membership, please visit bsigroup.com/shop.

With a **Multi-User Network Licence (MUNL)** you are able to host standards publications on your intranet. Licences can cover as few or as many users as you wish. With updates supplied as soon as they're available, you can be sure your documentation is current. For further information, email bsmusales@bsigroup.com.

BSI Group Headquarters

389 Chiswick High Road London W4 4AL UK

Revisions

Our British Standards and other publications are updated by amendment or revision.

We continually improve the quality of our products and services to benefit your business. If you find an inaccuracy or ambiguity within a British Standard or other BSI publication please inform the Knowledge Centre.

Copyright

All the data, software and documentation set out in all British Standards and other BSI publications are the property of and copyrighted by BSI, or some person or entity that owns copyright in the information used (such as the international standardization bodies) and has formally licensed such information to BSI for commercial publication and use. Except as permitted under the Copyright, Designs and Patents Act 1988 no extract may be reproduced, stored in a retrieval system or transmitted in any form or by any means – electronic, photocopying, recording or otherwise – without prior written permission from BSI. Details and advice can be obtained from the Copyright & Licensing Department.

Useful Contacts:

Customer Services

Tel: +44 845 086 9001

Email (orders): orders@bsigroup.com

Email (enquiries): cservices@bsigroup.com

Subscriptions

Tel: +44 845 086 9001

Email: subscriptions@bsigroup.com

Knowledge Centre

Tel: +44 20 8996 7004

Email: knowledgecentre@bsigroup.com

Copyright & Licensing

Tel: +44 20 8996 7070

Email: copyright@bsigroup.com



...making excellence a habit.™