

Test facilities for agricultural irrigation equipment

ICS 65.060.35

National foreword

This Published Document reproduces verbatim ISO/TR 15155:2005.

The UK participation in its preparation was entrusted to Technical Committee AGE/30, Irrigation and drainage equipment, which has the responsibility to:

- aid enquirers to understand the text;
- present to the responsible international/European committee any enquiries on the interpretation, or proposals for change, and keep UK interests informed;
- monitor related international and European developments and promulgate them in the UK.

A list of organizations represented on this committee can be obtained on request to its secretary.

Cross-references

The British Standards which implement international publications referred to in this document may be found in the *BSI Catalogue* under the section entitled “International Standards Correspondence Index”, or by using the “Search” facility of the *BSI Electronic Catalogue* or of British Standards Online.

Summary of pages

This document comprises a front cover, an inside front cover, the ISO/TR title page, pages ii to iv, pages 1 to 15 and a back cover.

The BSI copyright notice displayed in this document indicates when the document was last issued.

Amendments issued since publication

Amd. No.	Date	Comments

This British Standard was published under the authority of the Standards Policy and Strategy Committee on 26 July 2005

© BSI 26 July 2005

TECHNICAL
REPORT

**ISO/TR
15155**

First edition
2005-05-01

**Test facilities for agricultural irrigation
equipment**

Installations d'essais pour le matériel agricole d'irrigation



Reference number
ISO/TR 15155:2005(E)

Contents

Page

Foreword iv

1 Scope..... 1

2 Normative references 1

3 Terms and definitions..... 1

4 System components 2

5 Test facility procedures and policies..... 6

Annex A (informative) Sprinkler hydraulic properties in clear water..... 10

Annex B (informative) Drip emitters and emitting pipe hydraulic properties in clear water 12

Annex C (informative) Valves hydraulic properties in clear water 14

Licensed Copy: x x, The University of Sheffield, 28/06/2009 17:47, Uncontrolled Copy, (c) BSI

Foreword

ISO (the International Organization for Standardization) is a worldwide federation of national standards bodies (ISO member bodies). The work of preparing International Standards is normally carried out through ISO technical committees. Each member body interested in a subject for which a technical committee has been established has the right to be represented on that committee. International organizations, governmental and non-governmental, in liaison with ISO, also take part in the work. ISO collaborates closely with the International Electrotechnical Commission (IEC) on all matters of electrotechnical standardization.

International Standards are drafted in accordance with the rules given in the ISO/IEC Directives, Part 2.

The main task of technical committees is to prepare International Standards. Draft International Standards adopted by the technical committees are circulated to the member bodies for voting. Publication as an International Standard requires approval by at least 75 % of the member bodies casting a vote.

In exceptional circumstances, when a technical committee has collected data of a different kind from that which is normally published as an International Standard ("state of the art", for example), it may decide by a simple majority vote of its participating members to publish a Technical Report. A Technical Report is entirely informative in nature and does not have to be reviewed until the data it provides are considered to be no longer valid or useful.

Attention is drawn to the possibility that some of the elements of this document may be the subject of patent rights. ISO shall not be held responsible for identifying any or all such patent rights.

ISO/TR 15155 was prepared by Technical Committee ISO/TC 23, *Tractors and machinery for agriculture and forestry*, Subcommittee SC 18, *Irrigation and drainage equipment and systems*.

Test facilities for agricultural irrigation equipment

1 Scope

This Technical Report is intended to provide guidance on the design, selection, installation and use of the equipment required to establish basic test facilities for irrigation equipment evaluation. Its purpose is to provide information sufficient to complement the detailed procedures included in ISO 9261, ISO 15886, ISO 7714, ISO 9635, ISO 9644, ISO 9911, ISO 9952 and ISO 10522 for the testing of agricultural irrigation system components, specifically: emitters, sprinklers and valves.

2 Normative references

The following referenced documents are indispensable for the application of this document. For dated references, only the edition cited applies. For undated references, the latest edition of the referenced document (including any amendments) applies.

ISO 15886-1, *Agricultural irrigation equipment — Sprinklers — Part 1: Definition of terms and classification*

ISO 15886-3, *Agricultural irrigation equipment — Sprinklers — Part 3: Characterization of distribution and test methods*

ISO 9261, *Agricultural irrigation equipment — Emitters and emitting pipe — Specification and test methods*

ISO 7714, *Agricultural irrigation equipment — Volumetric valves — General requirements and test methods*

ISO 9635, *Irrigation equipment — Hydraulically operated irrigation valves*¹⁾

ISO 9644, *Agricultural irrigation equipment — Pressure losses in irrigation valves — Test method*

ISO 9911, *Agricultural irrigation equipment — Manually operated small plastics valves*

ISO 10522, *Agricultural irrigation equipment — Direct-acting pressure-regulating valves*

ISO/IEC 17025:1999, *General requirements for the competence of testing and calibration laboratories*

3 Terms and definitions

For the purposes of this document, the following terms and definitions apply.

3.1

test bench

collection of components, including water supply/receiving reservoir, piping, fittings and instrumentation, assembled to test an agricultural irrigation component

1) Under revision.

3.2 test facility
collection of components, including water supply, test bench(es) and shelter, used to test agricultural irrigation valves, sprinklers and emitters

3.3 net positive suction head available
arithmetic difference between the available total suction head at the impeller of a centrifugal pump and the vapour pressure head

3.4 net positive suction head required
arithmetic difference between the total suction head at the impeller of a centrifugal pump required for the pump to operate properly and the vapour pressure head, as specified by the manufacturer

3.5 static pressure head
sum of the head associated with atmospheric pressure and the gauge pressure head measured approaching the inlet of the impeller of a centrifugal pump

3.6 total suction head at the impeller of a centrifugal pump
sum of the static pressure head and the velocity head measured approaching the inlet of the impeller of a centrifugal pump and corrected to the centreline of the impeller for a centrifugal pump mounted horizontally or to the datum of the tip of the inlet vanes for a centrifugal pump mounted vertically

3.7 vapour pressure head
head associated with the absolute pressure at which a liquid vaporizes, as determined by the physical properties of the liquid and its temperature

4 System components

4.1 Pumps and pump environment

For specific requirements prior to selecting a pump, see Annex A for sprinklers, Annex B for emitters and emitting pipe, and Annex C for valves.

4.1.1 Selection

The size and type of pump selected depend on the requirements of the equipment to be tested. More than one pump may be required depending on the range of flows and pressures required by the equipment to be tested. Identify the equipment, test flow range and test pressure range before selecting a pump.

Select a centrifugal pump or a turbine pump based on the desired configuration of the test bench.

Ensure that the pumps and controls selected provide the required hydraulic characteristics continuously and without vibration that could affect the measurement accuracy. Dampen turbulence or use flow-straightening vanes in critical locations such as the inlet to a sprinkler test riser. Employ a variable-frequency drive (VFD) to control the motor, allowing the pump to operate over a wider range of flows and pressures.

Control the flow using equipment installed on the test bench (nozzle, emitters, valve, regulator and pipe size) and/or by the speed at which the pump is operated. Control flow and/or pressure with regulating valves on the inlet or outlet pipe, as needed.

Ensure that the pump is able to provide at least 110 % of the maximum pressure at 110 % of the maximum flow rate required for the device being tested. Review the pump curve for the selected pump to ensure it will operate over the required range.

4.1.2 Installation

Ensure that the pump is installed in a configuration that does not require priming and that the water supply/receiving tank has sufficient volume so that water temperature change during a test does not exceed the testing criteria.

Filtration is required to maintain the quality of the water supply and to meet the requirements of the equipment to be tested. If no specific filtration standard is required, the equivalent of a 200 mesh (75 microns) filter is recommended. Provide a by-pass circuit to effectively increase the operating range of the test bench.

See Figures 1, 2 and 3 for typical test bench configurations for testing valves, sprinklers and emitters.

4.1.3 Use

Ensure that proper safety equipment is installed and that operational procedures are documented. Refer to local codes to ensure that installation and use meet safety standards.

4.2 Pressure measurement

Measure pressure using a manometer filled with mercury or another calibrated liquid; manually read gauges or recording transducers with an analog or digital display or recorded directly using a data-logger. Ensure that the pressure range is higher than the expected pressures to prevent over-ranging of the gauge. See Annexes A, B and C for specifications.

4.2.1 Selection

The size and type of gauges required depend on the requirements of the equipment to be tested. More than one gauge may be required, depending on the range of pressures dictated by the equipment to be tested. Select a gauge that operates in the middle of its operating range for the test procedure and which is large enough to be easily read with increments as required by the accuracy indicated in the test procedure. A 100 mm dial face and a minimum accuracy of $\pm 0,5$ % of reading are recommended unless otherwise specified in the relative test procedure of the International Standard being used (see Clause 1 for mention of the relevant published standards). An electronic pressure transmitter can be used over a wide range of pressures.

Figure 4 illustrates eight consecutive pressure gauges for the range of 0 to 4 MPa (0 to 40 bar)²⁾, where the grey area defines the range of the pressure with accuracy higher than $\pm 0,5$ %.

4.2.2 Installation and location of sensors

Provide pressure taps at varying locations as required by the equipment being tested. Figure 5 shows information for design and installation of pressure taps. Locate gauges away from areas of excessive vibration.

It is preferable to have pressure measurements made at the same elevation as the pressure tap and at the exact location at which the pressure information is required, in order to eliminate mathematical calculations and approximations. If this is not physically possible, make a correction for the elevation difference. A correction is also required if differential pressure measurements are made in pipes of a different size.

2) 1 bar = 0,1 MPa = 10^5 Pa; 1 MPa = 1 N/mm²

4.2.3 Calibration and certification

Ensure that pressure taps are designed to allow easy access for pressure gauge inspection and maintenance. A regular calibration schedule is required to ensure the continuing reliability of the readings. Give each gauge an identification number and maintain a calibration log. Use commercial dead weight testers to calibrate gauges. In general, check calibration before and after a specific test program. Inspection frequency and operation should comply with ISO/IEC 17025.

4.3 Flow and volume measurement

Measure actual flow rate and accumulated volume using calibrated flow meters or by recording the duration of the flow and the mass or volume of the water or other liquid and then calculating the flow rate and total flow. Electromagnetic-type flow meters are considered the most accurate type of flow meter.

4.3.1 Flow meter alternatives and selection

There are several types of flow meters that are classified according to the operating principle. Turbine, impeller, magnetic, and positive displacement types depend on a sensor installed in the piping system. Differential-pressure types depend on orifice plates in the piping system. Install the meters or sensors as specified by the manufacturer.

Select a set of flow meters that give the required accuracy over the range of flow rates of the devices to be tested. The volumetric method may be used for devices with low flow rates such as nozzles and emitters and a flow meter for higher-flow devices. Select a meter that is durable and maintains calibration.

4.3.2 Volumetric (time and mass/volume)

Time and mass or time and volume can be used to determine flow rate and volume over the selected time period. The time and mass method is easier to automate. Although this method is more difficult to design into a test bench, the need for periodic calibration is greatly reduced. Calibration of the mass or volume scale is required less frequently (annually) than calibration of a flow meter and is a simpler procedure. Once the receiving tank has been calibrated, there should be no need to re-calibrate unless the tank is relocated or damaged. This method may not be practical for measuring total volume of devices requiring high flow rates unless a large receiving tank is constructed.

4.3.3 Installation and maintenance

4.3.3.1 Piping considerations

Ensure that piping is large enough so that pressure losses or turbulent flow in the system do not affect the test procedures or measurement conditions. Design for a recommended velocity of 2,5 m/s. If a centrifugal pump is selected, the intake should be straight into the pump with no changes in diameter and it should be carefully checked for air suction leaks. The net positive suction head available (NPSHa) should be at least 2 m greater than the net positive suction head required (NPSHr).

All return flows should be discharged below the free water surface to reduce the potential of introducing entrained air into the system.

4.3.3.2 Location considerations

Install the flow meter as specified by the manufacturer. If installation instructions are not provided, install the flow meter at least 10 pipe diameters downstream and at least 5 pipe diameters upstream from any fitting or restriction. Alternatively, flow-straightening vanes may be installed to reduce turbulence if adequate pipe length is not available.

4.3.4 Calibration and certification

Periodically inspect the flow meter for wear, corrosion, or contamination. A dedicated calibration verification schedule, required to maintain the reliability of the readings, should comply with ISO/IEC 17025.

4.4 Test bench design

Annexes A, B and C.

4.4.1 Pressure control

Control the pressure using one or more of the following devices:

- a correctly sized pressure regulator;
- a pressure sustaining valve;
- a manually controlled valve;
- a downstream air shaft.

Refer to the appropriate International Standard.

4.4.2 Flow control

Regulate the flow rate

- using a by-pass with a valve that returns excess flow to the water reservoir tank,
- using a flow control valve,
- using a VFD on the pump motor,
- by selecting another pump, or
- by using multiple pumps.

The regulation should be as automatic as possible. Refer to the appropriate International Standard (see Clause 1).

4.5 Water processing

4.5.1 Screens and filters

Filtration requirements vary depending on the equipment being tested. If no specific filtration standard is specified and if filtration is desired, the equivalent of a 200 mesh (75 microns) filter is recommended. Refer to the filter manufacturer's literature for operation and maintenance procedures.

Operation of irrigation components without proper filtration could lead to premature failure of the component. If the purpose is to evaluate a component capable of handling unfiltered water for durability, a filter is not required, but the evaluator should be aware of potential problems with plugged sensors.

Automatic self-cleaning strainer-type filters could produce variations of flows and pressures during the test and are not recommended. If these filters are used, ensure that the backflushing is turned off.

4.5.2 Disinfection

Methods of disinfection include the following.

- a) Maintain a minimum of 5 ppm³⁾ chlorine in the water to prevent algae growth. Use a liquid source of chlorine to reduce health and safety risks.
- b) Ozone treatment.
- c) Ultraviolet treatment.

4.5.3 Temperature control

Generally, recording water temperature is sufficient, unless specific requirements are specified in the test procedures. Record the temperature at least three times during the test — at the start, in the middle and at the end — unless otherwise specified. Annexes A, B and C.

4.6 Turbulence considerations

Annexes A, B and C.

5 Test facility procedures and policies

ISO/IEC 17025:1999 contains procedures for data collection and data management and its Clause 1 states that it is “applicable to all laboratories regardless of the number of personnel or the extent of the scope of testing and/or calibration activities. When a laboratory does not undertake one or more of the activities covered by this International Standard, such as sampling and the design/development of new methods, the requirements of those clauses do not apply.”

5.1 ISO 9000 certification

Compliance with ISO/IEC 17025:1999 ensures that the test facilities also operate in accordance with ISO 9001:2000.

5.2 Test results confidentiality

Test results are the property of the client, provided the fee paid was full cost recovery. Develop a written policy to meet local requirements and the intent of the test facilities.

5.3 Records

Refer to ISO/IEC 17025:1999, 4.12.

5.4 Test specimen management

Refer to ISO/IEC 17025:1999, 5.8.

3) “Parts per million (ppm)” is a deprecated unit, i.e. not accepted by the International System of Units, SI. It is used exceptionally in this Technical Report in order to correspond to other, closely related and already published standards. The accepted SI form for the expression of a volume fraction is in units of microlitres per litre (µl/l), or, alternatively, as 10⁻⁶ or as a percentage by volume (% by volume); for mass fractions it is expressed in micrograms per gram (µg/g). See ISO 31-0:1992, 2.3.3, and ISO 31-8-15:1992.

5.5 Public access to facilities and test results

Develop a written policy to meet local requirements and the intent of the test facilities.

5.6 Vendor testing of competitors' products

Develop a written policy to meet local requirements and the intent of the test facilities.

5.7 Commercial use of test data

Develop a written policy to meet local requirements and the intent of the test facilities.

5.8 Expert witness policy

Develop a written policy to meet local requirements and the intent of the test facilities.

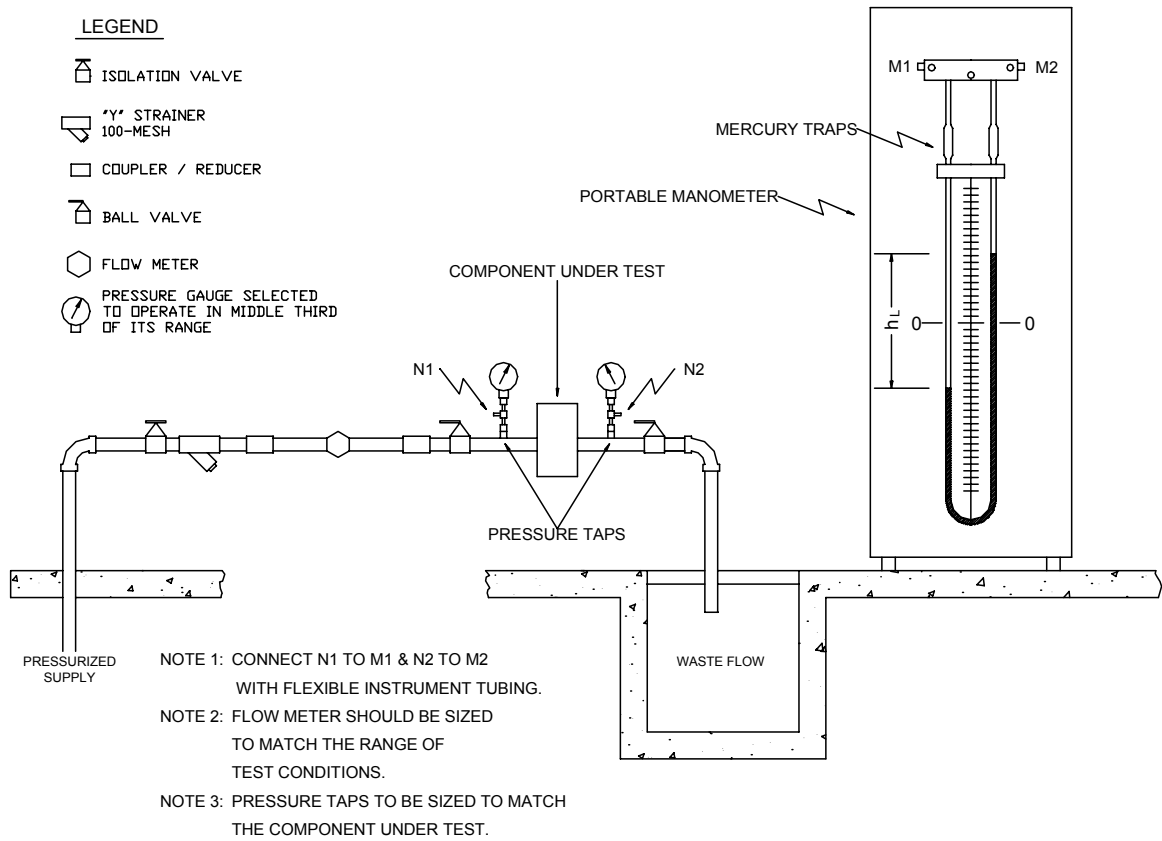

Figure 1 — Typical test bench configurations for testing valves

Licensed Copy: x x, The University of Sheffield, 28/06/2009 17:47, Uncontrolled Copy, (c) BSI

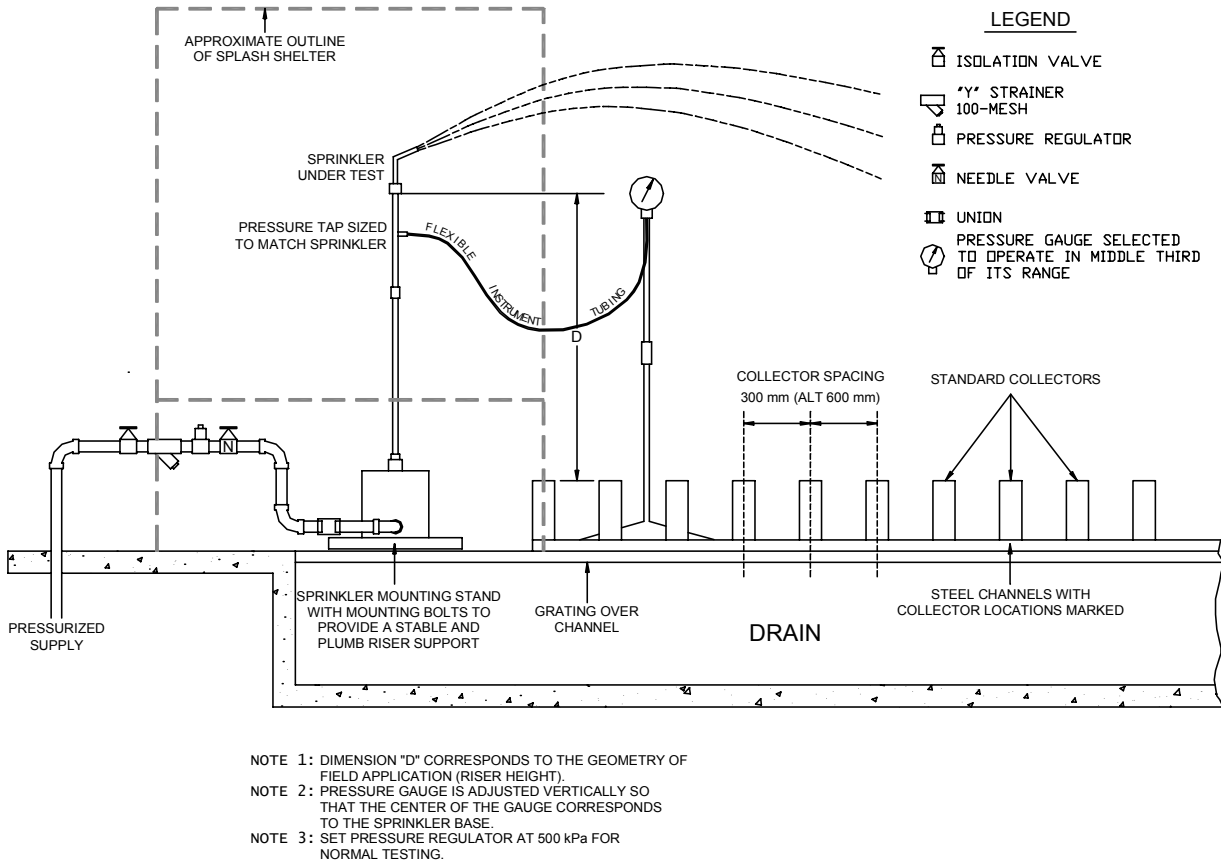

Figure 2 — Typical test bench configurations for testing sprinklers

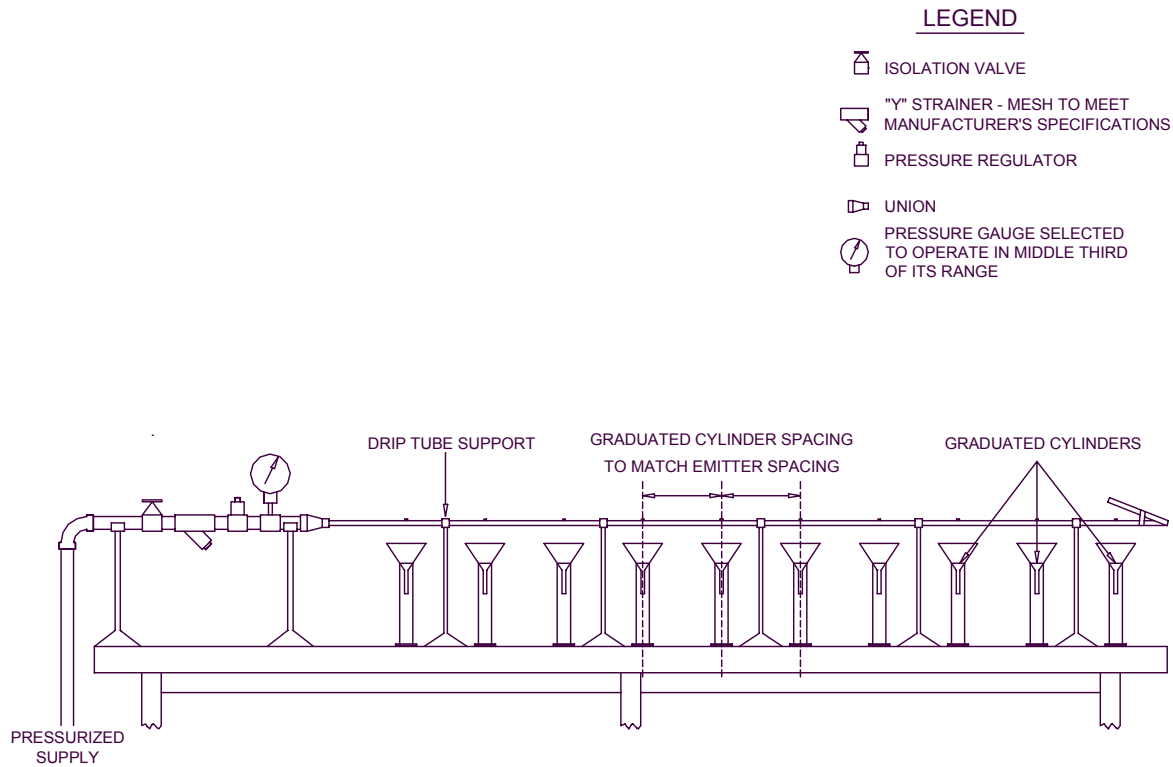

Figure 3 — Typical test bench configurations for testing emitters

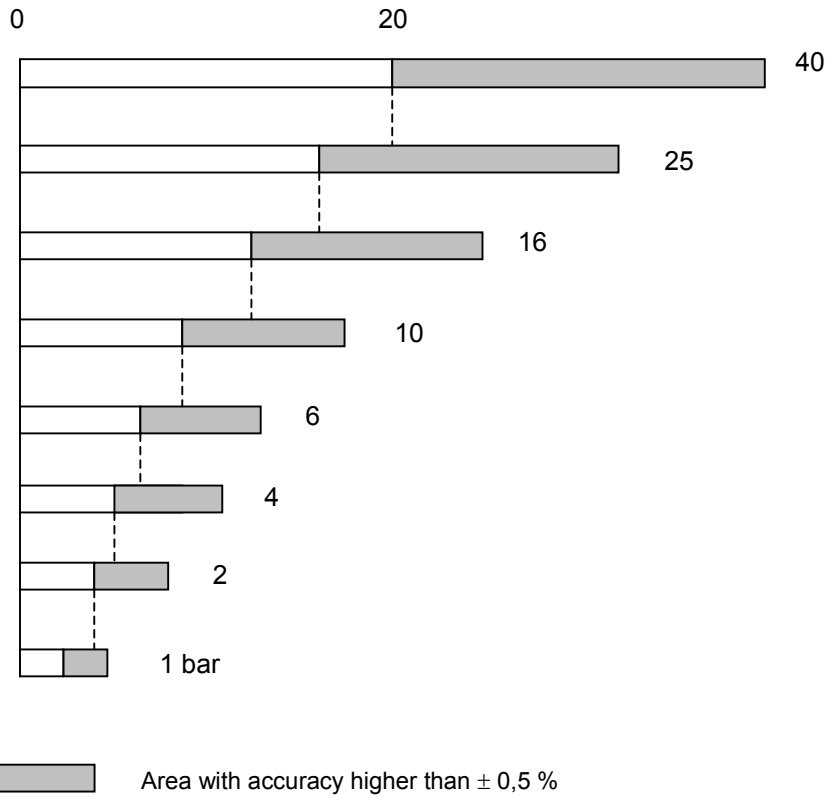
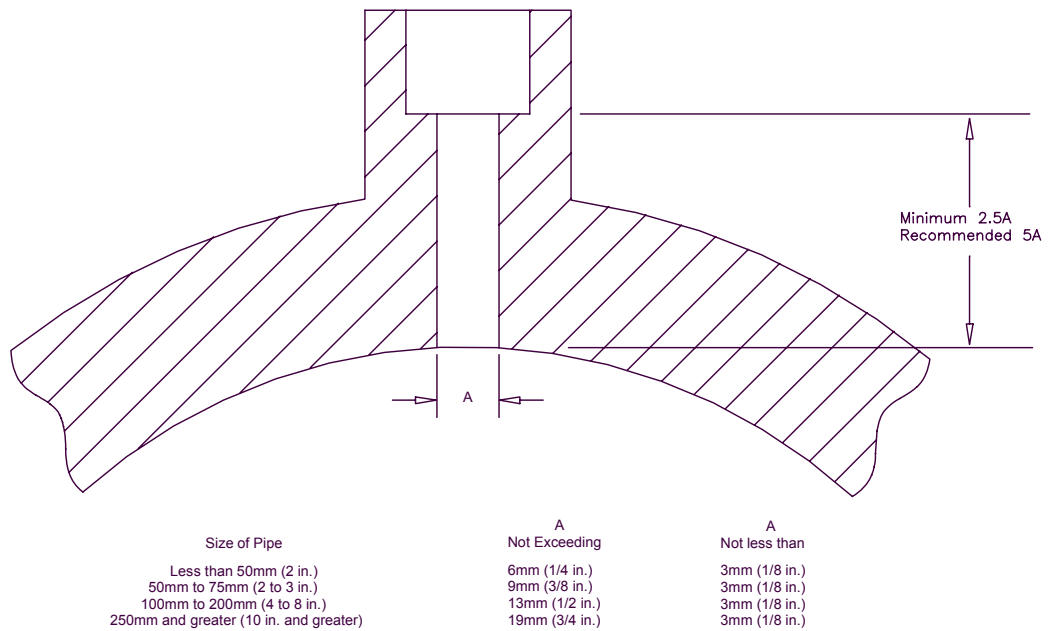

Figure 4 — Example of a range of pressure gauges for a test facility



Edge of hole must be clean and sharp or slightly rounded, free from burrs, wire edges or other irregularities.
 In no case shall any fitting protrude inside the pipe.
 Any suitable method of making the physical connection is acceptable if above recommendations are satisfied.
 Reference: ASME Performance Test Code PTC 19.5-1972, "Applications. Part II of fluid Meters, Interim Supplement on Instruments and Apparatus."

Figure 5 — Design and installation of pressure taps

Annex A
(informative)

Sprinkler hydraulic properties in clear water

Refer to ISO 15886-1 and ISO 15886-3.

Building	See ISO 15886-3 (typically 30 m × 10 m × 6 m high) Humidity control (arid conditions) Temperature control (cold conditions) Ventilation
Outdoor test site	See ISO 15886-3
Sprinkler shelter	Minimum opening angle 45° and height 2 m, minimum size 2 m × 2 m × 2 m, inside cover designed to absorb jet splash
Pump	Type: preferably centrifugal (flat curve) or turbine with variable-frequency drive Range: capacity 110 % of maximum required pressure and flow rate or 7,0 l/s at 0,7 MPa (7,0 bar) for indoor test
Test bench	Type: steel or PVC piping, recirculating system Range: 25 to 100 mm Requirements: including by-pass for pressure and flow regulation
Water reservoir and conditioning	2 000 l reservoir or match to maintain temperature criteria Filtration: 1,5 mm or match to nozzle size Temperature: maintain within ± 2,5 °C
Pressure regulation	Adjustable meeting requirements of various standards Accuracy: ± 2,5 %
Pressure gauges	Type: Bourdon or electronic pressure transmitters Range: 0 to 0,6 MPa (0 to 6 bar); 0 to 1 MPa (0 to 10 bar) Dial: 150 mm minimum diameter Accuracy: ± 1 %
Flow measurement	Accommodating the following range of flow: 2 to 750 l/min, with accuracy given in relevant standard (± 2,5 %)
Control valves	Type: throttling valve (globe and/or needle valve) Requirements: fine adjustment and holding setting
Sprinkler mounting	Avoiding creation of any turbulence that could impact the sprinkler performance (see ISO 15886-3)
Collector design	At least conforming to ISO 15886-3
Application measurement	Weighing or volumetric methods meeting accuracy requirement of ISO 15886-3

Wind measurement	Type: mechanical with analog or electronic readout Accuracy: $\pm 1\%$ Resolution: 0,1 m/s Requirements: average wind speed provided every 5 s
Temperature measurement	Type: mechanical or electronic Range: 0 to 45 °C Accuracy: $\pm 0,5\text{ °C}$
Other measurement devices	Time: $\pm 0,1$ second accuracy Distance: $\pm 1\%$ of the measured distance
Life testing	To be covered in a future part of ISO 15886
Water tightness	To be covered in a future part of ISO 15886
Facility data sheet	Highly recommended to keep a hard copy of test results and to design a stylized datasheet
Data analysis	Computerized results with appropriate software in order to verify: flow rate reconstitution Overlap patterns calculation

Annex B
(informative)

Drip emitters and emitting pipe hydraulic properties in clear water

Refer to ISO 9261.

Building	See ISO 9261 (typically 12 m × 6 m) Humidity control (arid conditions) Temperature control (cold conditions) Still air
Pump	Type: preferably centrifugal (flat curve) or turbine with variable-frequency drive Range: capacity 110 % of maximum required pressure and flow rate or 1 000 l/h at 0,5 MPa (5,0 bar)
Test bench	Requirements: designed to allow measurement of 25 emitters together 12 to 25 mm piping, as required Loop mounting to avoid pressure differences between emitters in test Device to direct the flow or drops to the collectors Special system to install or remove all collectors simultaneously By-pass for pressure and flow regulation Water collection devices
Control valves	Type: globe valve for coarse control and needle valve for fine control Requirements: fine adjustment and holding setting
Water reservoir and conditioning	Capacity: minimum 200 l reservoir Filtration: 200 mesh (75 microns) Temperature: ± 3,0 °C
Pressure regulation	Adjustable to meet requirements of various standards or 30 to 500 kPa Accuracy: ± 1 %
Pressure gauges	Type: Bourdon, electronic pressure transmitters or mercury manometer (well type), range 0 to 500 mm Range: 0 to 0,1 MPa (0 to 1 bar); 0 to 0,2 MPa (0 to 2 bar); 0 to 0,5 MPa (0 to 5 bar) Dial: 150 mm minimum diameter Accuracy: ± 1 %

Temperature measurement and control	<p>Type: mechanical or electronic</p> <p>Range: 5 to 60 °C</p> <p>Accuracy: ± 1 °C</p> <p>Heating and cooling equipment provided to maintain the required test range</p>
Other measurement devices	<p>Time: stop watch with ± 0,1 s accuracy</p> <p>Distance: ± 1 % of the measured distance</p>
Test stand for tensile measurement	See ISO 9261
Tubing diameter and wall thickness measurement device	See ISO 9261
Facility data sheet	Highly recommended to keep a hard copy of test results and to design a stylized datasheet
Data analysis	Computerized results with appropriate software in order to verify: flow rate reconstitution

Annex C
(informative)

Valves hydraulic properties in clear water

Refer to ISO 7714, ISO 9635 and ISO 10522.

Building	25 m × 10 m × 6 m high sump and channel preferably heated
Bridge crane or arm hoists	1-tonne or higher
Pump(s)	For valves up to DN200: — 1–14 l/s at 0,5 MPa (5 bar); — 2–55 l/s each at 0,5 MPa (5 bar). For valves up to DN600: — 1–14 l/s at 0,5 MPa (5 bar); — 2–55 l/s each at 0,5 MPa (5 bar). — 2–110 l/s at 0,5 MPa (5 bar). The pumps can be connected in parallel to increase flow or in series to increase pressure. Hydrostatic pressure test at 5 MPa (50 bar)
Test benches	Range: 25 to 80 mm, 100 to 250 mm, 250 to 600 mm Rating: PN 16, PN 25 Accessories: assorted valves and reducers pressure tap pipes (25 mm to 600 mm)
Flow conditioning (temperature, filtration)	Filtration: 20 mesh screen filter Temperature: 5 to 45 °C, accuracy ± 1 °C
Pressure regulation	Pressure regulator or manually controlled valves Gate valve (25 mm to 500 mm), globe valve, butterfly valve VFD Multiple pumps Water hammer avoided
Flow control	Automatic flow control valve or manually controlled valves that hold their setting
Differential pressure gages	Type: mercury manometers or differential pressure gauge Range: 0 to 0,16 MPa (0 to 1,6 bar)

Flow meters	<p>Type: electromagnetic or turbine with digital readout and totalizer</p> <p>Range: 25 mm for 0,6 to 3,0 l/s 100 mm for flow of 0 to 25,0 l/s 250 mm for flow of 500 l/s</p> <p>Accuracy: $\pm 0,5 \%$</p>
Pressure measurement	<p>Type: Bourdon or electronic pressure transmitters</p> <p>Range: 0 to 0,6 MPa (0 to 6 bar); 0 to 1 MPa (0 to 10 bar); 0 to 6 MPa (0 to 60 bar)</p> <p>Dial: 150 mm minimum diameter</p> <p>Accuracy: $\pm 2,5 \%$</p>
Valve close high-speed pressure measurement, surge measurement	Recording pressure gauge with a response time $< 0,1$ s

BSI — British Standards Institution

BSI is the independent national body responsible for preparing British Standards. It presents the UK view on standards in Europe and at the international level. It is incorporated by Royal Charter.

Revisions

British Standards are updated by amendment or revision. Users of British Standards should make sure that they possess the latest amendments or editions.

It is the constant aim of BSI to improve the quality of our products and services. We would be grateful if anyone finding an inaccuracy or ambiguity while using this British Standard would inform the Secretary of the technical committee responsible, the identity of which can be found on the inside front cover.
Tel: +44 (0)20 8996 9000. Fax: +44 (0)20 8996 7400.

BSI offers members an individual updating service called PLUS which ensures that subscribers automatically receive the latest editions of standards.

Buying standards

Orders for all BSI, international and foreign standards publications should be addressed to Customer Services. Tel: +44 (0)20 8996 9001.
Fax: +44 (0)20 8996 7001. Email: orders@bsi-global.com. Standards are also available from the BSI website at <http://www.bsi-global.com>.

In response to orders for international standards, it is BSI policy to supply the BSI implementation of those that have been published as British Standards, unless otherwise requested.

Information on standards

BSI provides a wide range of information on national, European and international standards through its Library and its Technical Help to Exporters Service. Various BSI electronic information services are also available which give details on all its products and services. Contact the Information Centre.
Tel: +44 (0)20 8996 7111. Fax: +44 (0)20 8996 7048. Email: info@bsi-global.com.

Subscribing members of BSI are kept up to date with standards developments and receive substantial discounts on the purchase price of standards. For details of these and other benefits contact Membership Administration.
Tel: +44 (0)20 8996 7002. Fax: +44 (0)20 8996 7001.
Email: membership@bsi-global.com.

Information regarding online access to British Standards via British Standards Online can be found at <http://www.bsi-global.com/bsonline>.

Further information about BSI is available on the BSI website at <http://www.bsi-global.com>.

Copyright

Copyright subsists in all BSI publications. BSI also holds the copyright, in the UK, of the publications of the international standardization bodies. Except as permitted under the Copyright, Designs and Patents Act 1988 no extract may be reproduced, stored in a retrieval system or transmitted in any form or by any means – electronic, photocopying, recording or otherwise – without prior written permission from BSI.

This does not preclude the free use, in the course of implementing the standard, of necessary details such as symbols, and size, type or grade designations. If these details are to be used for any other purpose than implementation then the prior written permission of BSI must be obtained.

Details and advice can be obtained from the Copyright & Licensing Manager.
Tel: +44 (0)20 8996 7070. Fax: +44 (0)20 8996 7553.
Email: copyright@bsi-global.com.