



BSI Standards Publication

# Computational structural fire design — Review of calculation models, fire tests for determining input material data and needs for further development

**National foreword**

This Published Document is the UK implementation of ISO/TR 12471:2004.

The UK participation in its preparation was entrusted to Technical Committee FSH/22, Fire resistance tests.

A list of organizations represented on this committee can be obtained on request to its secretary.

This publication does not purport to include all the necessary provisions of a contract. Users are responsible for its correct application.

© BSI 2011

ISBN 978 0 580 69332 8

ICS 13.220.50

**Compliance with a British Standard cannot confer immunity from legal obligations.**

This Published Document was published under the authority of the Standards Policy and Strategy Committee on 31 July 2011.

**Amendments issued since publication**

Date	Text affected
------	---------------

---

# TECHNICAL REPORT

# ISO/TR 12471

First edition  
2004-11-15

---

---

## **Computational structural fire design — Review of calculation models, fire tests for determining input material data and needs for further development**

*Conception de calcul des feux de structures — État des travaux des  
modèles de calcul et d'essais au feu pour la détermination des données  
de base requises et des besoins du développement ultérieur*



Reference number  
ISO/TR 12471:2004(E)

© ISO 2004

**PDF disclaimer**

This PDF file may contain embedded typefaces. In accordance with Adobe's licensing policy, this file may be printed or viewed but shall not be edited unless the typefaces which are embedded are licensed to and installed on the computer performing the editing. In downloading this file, parties accept therein the responsibility of not infringing Adobe's licensing policy. The ISO Central Secretariat accepts no liability in this area.

Adobe is a trademark of Adobe Systems Incorporated.

Details of the software products used to create this PDF file can be found in the General Info relative to the file; the PDF-creation parameters were optimized for printing. Every care has been taken to ensure that the file is suitable for use by ISO member bodies. In the unlikely event that a problem relating to it is found, please inform the Central Secretariat at the address given below.

© ISO 2004

All rights reserved. Unless otherwise specified, no part of this publication may be reproduced or utilized in any form or by any means, electronic or mechanical, including photocopying and microfilm, without permission in writing from either ISO at the address below or ISO's member body in the country of the requester.

ISO copyright office  
Case postale 56 • CH-1211 Geneva 20  
Tel. + 41 22 749 01 11  
Fax + 41 22 749 09 47  
E-mail [copyright@iso.org](mailto:copyright@iso.org)  
Web [www.iso.org](http://www.iso.org)

Published in Switzerland

## Contents

Page

Foreword.....	iv
Introduction .....	v
1 Scope.....	1
2 Internationally applied methods for structural fire engineering design .....	1
2.1 Models for thermal exposure.....	2
2.2 Models for structural behaviour .....	6
3 Characteristics of a reliability-based structural fire engineering design <sup>[56]</sup> .....	7
3.1 Structural fire engineering design based on FORM approximation .....	7
3.2 Structural fire engineering design based on practical design format.....	10
4 Predictive model capabilities: uncertainties of design components <sup>[56]</sup> .....	13
5 Main components of structural fire engineering design.....	17
5.1 Design fire exposure.....	17
5.2 Thermal material properties and transient temperature state.....	25
5.3 Mechanical material properties and structural behaviour.....	29
6 Need for further development of calculation models and related computer programs for structural fire design: Examples .....	40
6.1 Complete process of structural fire design .....	40
6.2 Main components of structural fire design .....	41
6.2.1 Fire exposure.....	41
6.2.2 Thermal and mechanical behaviour.....	41
7 Need for fire tests to determine input material data for structural fire design.....	42
7.1 Properties related to fire load density and fire exposure .....	42
7.2 Thermal material properties.....	43
7.3 Mechanical material properties .....	44
Bibliography .....	46

## Foreword

ISO (the International Organization for Standardization) is a worldwide federation of national standards bodies (ISO member bodies). The work of preparing International Standards is normally carried out through ISO technical committees. Each member body interested in a subject for which a technical committee has been established has the right to be represented on that committee. International organizations, governmental and non-governmental, in liaison with ISO, also take part in the work. ISO collaborates closely with the International Electrotechnical Commission (IEC) on all matters of electrotechnical standardization.

International Standards are drafted in accordance with the rules given in the ISO/IEC Directives, Part 2.

The main task of technical committees is to prepare International Standards. Draft International Standards adopted by the technical committees are circulated to the member bodies for voting. Publication as an International Standard requires approval by at least 75 % of the member bodies casting a vote.

In exceptional circumstances, when a technical committee has collected data of a different kind from that which is normally published as an International Standard ("state of the art", for example), it may decide by a simple majority vote of its participating members to publish a Technical Report. A Technical Report is entirely informative in nature and does not have to be reviewed until the data it provides are considered to be no longer valid or useful.

Attention is drawn to the possibility that some of the elements of this document may be the subject of patent rights. ISO shall not be held responsible for identifying any or all such patent rights.

ISO/TR 12471 was prepared by Technical Committee ISO/TC 92, *Fire safety*, Subcommittee SC 2, *Fire containment*.

## Introduction

Considerable advances have been made in recent years in understanding the behaviour of fires in their development and impact upon buildings. Coupled with developments in computational techniques, it is now possible to predict how structures will behave at the fire limit state (i.e. under fire conditions).

As a result of the high level of international fire research in recent decades, more and more components and systems are becoming amenable to analytical and computer modelling. Considerable progress has been made concerning such phenomena and procedures as:

- reaction of materials to fire;
- fire growth in a compartment;
- fully developed compartment fire;
- fire spread between buildings;
- fire behaviour of load-bearing and separating building structures;
- smoke filling in enclosures and smoke movement in escape routes and multi-storey buildings;
- interaction of sprinklers and fire, including sprinkler and fire venting interaction;
- process of escape; and
- systems approach to the overall fire safety of a building, in its most general form comprising fire development models interacting with human response models.

This progress in fire research has led to consequent changes in the field of codes, specifications, and recommendations for fire engineering. Some characteristic trends in these changes are:

- a) improved connection to real fire scenarios;
- b) increase in extent of design, based on functional requirements and performance criteria;
- c) development of new test methods, that are, as far as possible, material-independent and related to well-defined phenomena and properties;
- d) increase in application of reliability-based analytical design;
- e) extended use of integrated assessments; and
- f) introduction of goal-oriented systems of analysis of total, active and passive fire protection for a building.

The most manifest verification of these developing trends probably relates to the fire engineering design of load-bearing and separating structures. An analytical determination of the fire resistance of structural elements is being approved by authorities in more and more countries as an alternative to the internationally predominant design that is based on the results of the standard fire resistance test and connected classification. The further step to permit a general practical application of an analytical design, based on a natural compartment fire concept, was taken by Swedish authorities as early as 1967. Since then, a few other countries have been officially open to the possibility of structural fire design.

A significant contribution was made by the Fire Commission of the Conseil International du Bâtiment, CIB W14, in the form of a state-of-the-art report, in 1983. The report presented a conceptual approach towards a

probability-based design guide on structural fire safety<sup>[1]</sup>, supplemented in 1986 by a model code/design guide<sup>[2]</sup>. These design guides are important aids in drafting corresponding national regulations and recommendations. For European countries, the Eurocodes (see references [3] to [10] in the Bibliography) issued as European Prestandards and supplemented with national application documents, certainly will contribute to increased practical use of analytical structural fire design methods.

A problem arises between material-related codes and the general code. The material-related codes focus very strongly on the fire design, based on thermal exposure according to the standard fire resistance test. However, the general code, specifying the basis of design and mechanical and thermal actions on fire-exposed structures, also gives some guidance, in the form of informative annexes, regarding the alternate structural fire design, based on a parametric fire exposure determined by fire models or specified temperature-time curves.

An analytical fire engineering design can now be performed in most cases for steel structures. Validated material models for the mechanical behaviour of concrete under transient high-temperature conditions<sup>[11] to [13]</sup> and thermal models for a calculation of the charring rate in wood exposed to fire<sup>[14] to [16]</sup>, developed in recent decades, have significantly enlarged the area of practical application of an analytical structural fire design. To support this application, design diagrams and tables have been computed and published, giving directly, on the one hand, the temperature state of the fire-exposed structure, and on the other, a further transfer to the corresponding load-bearing capacity of the structure, for instance see references [17] to [47] in the Bibliography.

The following clauses begin with a summary of internationally applied methods for a structural fire engineering design. With this survey as general background, the characteristics of a reliability-based approach are described. In order to review the need for further development of calculation models and for fire tests to get the input data required for the design, the design alternative, based on a simulated fire exposure, has been chosen for presentation. For other design alternatives, applied in practice, the need for calculation models and related input data is less comprehensive than for the more general approach being dealt with. The presentation is followed by a discussion about uncertainty in the design process.

Following this background presentation of the reliability-based design process and its inherent uncertainties, the remaining document is devoted to related deterministic models, comprising the fire exposure and the thermal and mechanical behaviour of the structure. These models are supplemented with a survey of the material input data required for the structural fire engineering design. Finally, conclusions are drawn regarding the need for further development of calculation models and tests to determine the input material data required for the structural fire design.



# Computational structural fire design — Review of calculation models, fire tests for determining input material data and needs for further development

## 1 Scope

This Technical Report gives a review of the advances that have been made in measuring and understanding how structural materials respond to fire in terms of changes in their elevated temperature, and physical and mechanical characteristics, and to identify areas where further work is necessary to generate the data required. Analytical methods for heat transfer are combined with mechanical models to calculate structural behaviour from single elements up to complete frames under real fire and ISO Standard furnace heating conditions. This Technical Report reviews advances in computational analysis and indicates how these can be used with probabilistic analysis to provide a risk-based approach to structural fire engineering design.

## 2 Internationally applied methods for structural fire engineering design

The methods available at present for a structural fire engineering design can systematically be characterized with reference to the matrix according to Table 1 [1] [2] [37].

The matrix is based on two types of models for the thermal exposure of the structure (H1 and H2) and three types of models for the mechanical behaviour of the structure (S1, S2 and S3).

**Table 1 — Matrix of thermal exposure and structural behaviour models, characterizing available methods for structural fire engineering design**

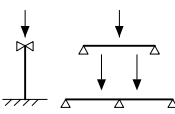
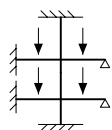
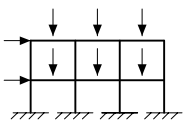
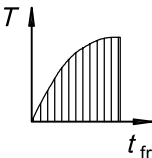
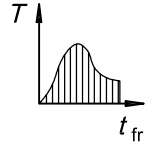
Model for thermal exposure		Model for structure		
		S1	S2	S3
		Element	Substructure	Complete structure
				
H1	Nominal temperature-time curves 	Test or calculation (deterministic)	Calculation exceptionally testing (deterministic)	
H2	Real fire 	Calculation (probabilistic)	Calculation (probalistic)	Calculation (probabilistic) in special cases and for research

## 2.1 Models for thermal exposure

**Model H1** describes the thermal exposure according to the standard fire resistance test of structural elements as specified in the ISO 834<sup>[48]</sup> and in corresponding national standards, or according to some other nominal temperature-time curve<sup>[3]</sup>. A fire design, based on this thermal exposure, represents the internationally prevalent situation for load-bearing and separating structural elements.

In the standard fire resistance test, the specimen is exposed in a furnace to a temperature rise that is controlled so as to vary with time within specified limits according to the standard temperature-time curve

$$T_t - T_0 = 345 \log_{10}(8t + 1) \quad (1)$$

where

$t$  is the time, in minutes;

$T_t$  is the furnace temperature at time  $t$ , in °C;

$T_0$  is the furnace temperature at time  $t = 0$ , in °C.

For calculations, it is normally more favourable to use the following expression for the standard temperature-time curve

$$T_t - T_0 = 1025 \left( 1 - 0,324e^{-0,2t} - 0,204e^{-1,7t} - 0,472e^{-19t} \right) \quad (2)$$

that describes Equation (1) to a fairly high degree of accuracy, as shown in reference [49] in the Bibliography. In Equation (2), then  $t$  is time, in hours.

Other nominal temperature-time curves are the hydrocarbon curve

$$T_t - T_0 = 1080 \left( 1 - 0,325e^{-0,167t} - 0,675e^{-2,5t} \right) \quad (3)$$

representing thermal exposure on structural members due to hydrocarbon type fires, and the external fire curve

$$T_t - T_0 = 660 \left( 1 - 0,687e^{-0,32t} - 0,313e^{-3,8t} \right) \quad (4)$$

representing thermal exposure on the outside of external walls and on other external members as beams and columns<sup>[3]</sup>. See Figure 1.

In the test, the time to reach the decisive limit state with respect to the load-bearing and/or separating function of the structural element defines its fire resistance, normally expressed in minutes. As an alternative, the fire resistance can be determined by calculation.

Internationally, the standard fire resistance test is considered to be one of the fire test methods most thoroughly dealt with. In spite of this, the test can be criticized. In its present form, the test procedure is insufficiently specified in several respects, such as the heating and restraint characteristics, the environment of the furnace, and the thermocouples for measuring and regulating the furnace temperature. The specification of the test load is practically related to national building codes and regulations, which can vary considerably with respect to the load level required from country to country. Current activities within CEN and ISO are aimed at improving the test specifications.

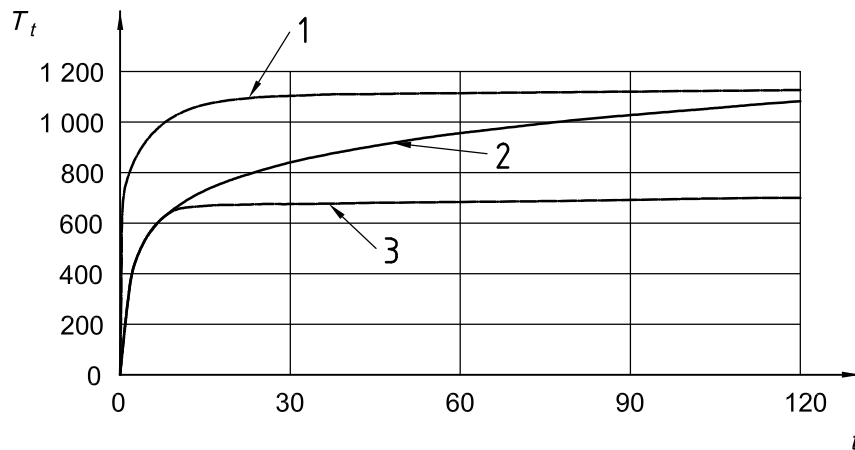

**Key**

- $t$  time, min
- $T_t$  temperature, °C
- 1 hydrocarbon
- 2 standard (ISO)
- 3 external
- $T_0 = 20$  °C

**Figure 1 — Temperature  $T_t$  as function of time  $t$  according to Equations (1) to (4)**

Irrespective of the fire resistance being determined by testing or by calculation, it is important to consider that the standard fire resistance test does not represent the real fire exposure in a building, nor does it measure the behaviour of the structural element as a part of an assembly in the building. It is further essential to have in mind that the standard fire duration, applied in a test, does not represent the real fire duration. What the test or the corresponding calculations do is to grade structural elements. The building codes and regulations then require different grading levels of elements depending on the circumstances.

**Model H2** describes a thermal exposure, based on a simulated real fire and either computed by solving the energy and mass balance equations of the compartment fire or determined from some systematized design basis, for instance, the parametric fire as specified in Eurocode 1<sup>[3]</sup>, or the set of gas temperature-time curves, illustrated and explained later in connection with Figure 13.

The two examples of design bases for the fully developed compartment fire exposure are both derived under the assumptions that

- combustion of the fire load takes place entirely within the fire compartment,
- the fire process is ventilation-controlled, and
- gas temperature is uniform within the fire compartment at any time,

giving a conservative solution. The specified fire exposure considers the influence of the opening factor of the compartment  $A\sqrt{h}/A_t$  and the thermal properties of the surrounding structures of the compartment, expressed by the thermal inertia  $\sqrt{\lambda\rho c}$ .  $A$  is the total area of the window and door openings, in  $m^2$ ;  $h$  is the mean value of the heights of the openings, weighted with respect to each individual opening area, in  $m$ ;  $A_t$  is the total area of the surfaces bounding the compartment, opening areas included, in  $m^2$ ;  $\lambda$  is the thermal conductivity, in  $W\cdot m^{-1}\cdot ^\circ C^{-1}$ ;  $\rho$  is the density, in  $kg\cdot m^{-3}$ ; and  $c$  is the specific heat, in  $J\cdot kg^{-1}\cdot ^\circ C^{-1}$ , of the compartment boundaries.

The parametric fire specifies the temperature-time curves of the heating phase of the compartment fire as the standard gas temperature-time curve according to Equation (2) with the real time  $t$  replaced by a modified time

$$t^* = t\Gamma \tag{5}$$

where

$$\Gamma = \left\{ \frac{A\sqrt{h}/A_t}{0,04} \times \frac{1160}{\sqrt{\lambda\rho c}} \right\}^2 \quad [\text{J}\cdot\text{m}^{-2}\cdot\text{s}^{-1/2}\cdot\text{°C}^{-1}] \quad (6)$$

The duration of the heating phase is given by the modified duration time

$$t_d^* = 1,3 \times 10^{-4} \frac{q_t \Gamma}{A\sqrt{h}/A_t} \quad [\text{h}] \quad (7)$$

where  $q_t$  is the design value of the fire load density per unit area of the total surfaces, bounding the fire compartment, in  $\text{MJ}\cdot\text{m}^{-2}$ .

For the decay period, the parametric fire exposure is specified by the following formulae:

$$\begin{aligned} T_t &= T_{t,\max} - 625 (t^* - t_d^*) && \text{for } t_d^* \leq 0,5 \text{ h} \\ T_t &= T_{t,\max} - 250 (3 - t_d^*) (t^* - t_d^*) && \text{for } 0,5 < t_d^* < 2 \text{ h} \\ T_t &= T_{t,\max} - 250 (t^* - t_d^*) && \text{for } t_d^* \geq 2 \text{ h} \end{aligned} \quad (8)$$

where  $T_{t,\max}$  is the maximum temperature in the heating phase, i.e. for  $t^* = t_d^*$ , in  $^{\circ}\text{C}$ .

When applying a Model H2 description of the thermal exposure, the design normally consists of an analytical or numerical procedure. Exceptionally, the design can refer to a full-scale test.

As a means to connect the thermal exposure according to the standard temperature-time curve, Equation (1) or (2), and the thermal exposure, based on a simulated real fire (Model H2), the concept of the **equivalent time of fire exposure** has been introduced. In practice, the concept can be used, for instance, for giving an improved classification for fire ranking or grading of structural elements.

In principle, the equivalent time of fire exposure is defined as that length of the heating period of the standard fire resistance test that gives the same decisive effect on a structural element with respect to a limit state as the complete process of a simulated real fire exposure. The concept is further explained by Figure 2, in which the full-line curves show the time variation of the gas temperature  $T_t$  and the load-bearing capacity  $R(t)$  of a structural element for a simulated real compartment fire exposure and the dash-line curves the standard temperature-time curve according to ISO 834  $T_{t,\text{ISO}}$  and the corresponding time curve of the load-bearing capacity  $R(t),\text{ISO}$ . The minimum load-bearing capacity of the structural element during the simulated real fire exposure, transferred to the same value of the load-bearing capacity at the standard thermal exposure, determines the equivalent time of fire exposure  $t_e$ .

For steel structures, the minimum load-bearing capacity during a simulated real fire exposure normally corresponds to the maximum steel temperature  $T_{s,\max}$ , provided that the temperature can be dealt with as uniformly distributed over the cross-section of the structure. This simplifies the definition of the equivalent time of fire exposure as shown in Figure 3.

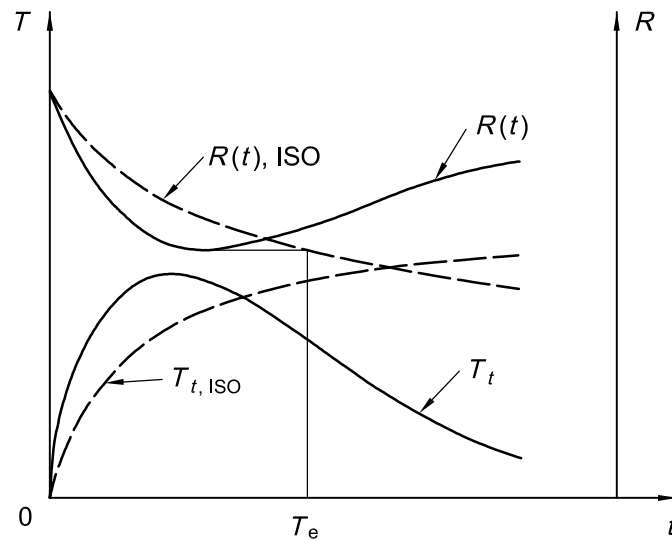

**Key**

$t$  time

$T$  temperature

$R$  load-bearing capacity

———— simulated real compartment fire exposure.

----- thermal exposure according to the standard fire resistance test, ISO 834.

**Figure 2 — Definition of equivalent time of fire exposure  $t_e$**

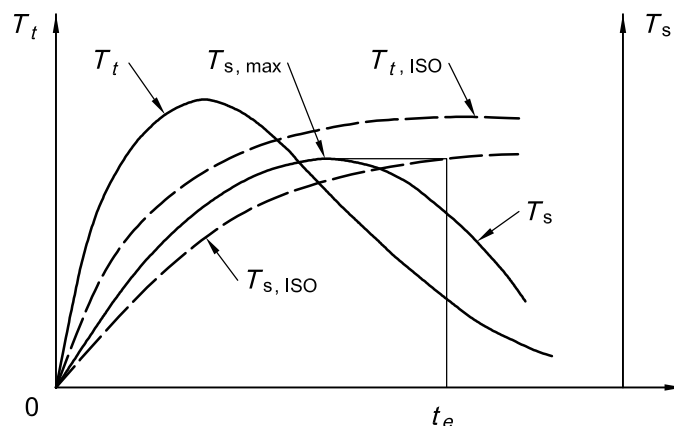

**Key**

$t$  time

$T_t$  gas temperature at time  $t$

$T_s$  steel temperature

**Figure 3 — Equivalent time of fire exposure  $t_e$  as defined by the maximum steel temperature  $T_{s,max}$  during a simulated real compartment fire exposure, exemplified for a protected structural steel element**

When determined according to Figures 2 and 3, the equivalent time of fire exposure depends on parameters influencing the simulated real fire exposure as well as on structural parameters (for protected steel structures: the thermal material properties and the geometry of the protection and the steel profile). For fire-exposed steel structures, references [18], [23], [50] and [51] include a design basis for a direct practical determination of this differentiated form of the equivalent time of fire exposure.

For more rough estimations of the equivalent time of fire exposure  $t_e$ , the following formula has been derived, taking into account only the factors affecting the simulated real fire exposure<sup>[50], [52], [53]</sup>:

$$t_e = 0,067 \frac{q_{tf}}{(A\sqrt{h}/A_t)_f^{0,5}} \quad [\text{min}] \quad (9)$$

where

- $q_{tf}$  is the fire load density per unit area of the total surfaces, bounding the fire compartment; in MJ·m<sup>-2</sup>;
- $A$  is the total area of window and door openings; in m<sup>2</sup>;
- $h$  is the mean value of the heights of the openings, weighted with respect to each individual opening area, in m;
- $A_t$  is the total interior area of the surfaces, bounding the compartment, opening areas included, in m<sup>2</sup>.

By using fictitious values of the fire load density  $q_{tf}$  and the opening factor  $(A\sqrt{h}/A_t)_f$ , the influence of varying thermal properties of the surrounding structures of the fire compartment can be considered<sup>[18]</sup>.

Summing up, the formula given by Equation (9) connects in a simplified way the thermal exposure according to the standard fire resistance test, ISO 834, and the thermal exposure of simulated, fully developed compartment fires. The formula has been verified for application mainly to steel structures and those reinforced concrete structures, where the critical concern is yielding of the reinforcement under bending conditions. At very low opening factors, the formula may give a considerable overestimation of the fire severity. There is also a limitation of the validity of the formula to compartments of moderate size, i.e. compartments with a size representative of dwellings, ordinary offices, schools, hospitals, hotels, and libraries. The technical basis for the formula is for small compartments. A study of the applicability of available relationships for the equivalent time of fire exposure to buildings with large compartments is reported in reference [54]. In reference [55], formulae for the equivalent time of fire exposure, from Ingberg to Eurocode 1, are systematically reviewed and compared with experimental data for compartment fires.

## 2.2 Models for structural behaviour

**Model S1** comprises single structural elements, e.g. beams, columns, walls, floors, and roofs. The model may simulate either a structural element or a single element isolated from the complete structure and described by simplified end conditions in the fire analysis.

**Model S2** means a substructure, which approximately describes the mechanical behaviour of a part of the complete load-bearing system of the building. Compared to the real structure, a substructure is analysed with simplified boundary conditions at its outer ends or edges.

**Model S3** describes the mechanical behaviour of the complete load-bearing structure of the building, acting as, for instance, a two- or three-dimensional frame, a beam-slab system or a column-beam-slab system.

In the matrix given in Figure 1, the thermal exposure models and the structural models are combined in the sequence of improved idealization. In principle, each element in the matrix then represents a particular design procedure. The matrix therefore can be considered as a type of classification system for methods of structural fire engineering design. It is, however, evident that not all models can be used in all combinations and the aim should be to provide a sensible pairing at each level of advancement. In the matrix, reference is made to these aspects. In principle, a structural fire engineering design offers a problem-oriented choice for the combination of the thermal exposure model and the structural behaviour model. The final choice may also depend on national preferences, the complexity of application, and the particular design situation.

### 3 Characteristics of a reliability-based structural fire engineering design [56]

Essential components of a rational design methodology include, in the ideal case<sup>[57], [58]</sup>:

- analytical modelling of relevant processes; verification of validation and accuracy; determination of critical design parameters;
- formulation of functional requirements, independent of choice of design process and expressed either in deterministic or probabilistic terms;
- determination of design parameter values; and
- verification by reliability analysis that the choice of safety factors leads to safety levels that are consistent with the expressed functional requirements.

For the probabilistic model to be integrated with the analytical model(s) of the relevant processes, the following levels can be distinguished:

- an exact evaluation of the failure probability, using multi-dimensional integration or Monte Carlo simulation;
- an approximate evaluation of the failure probability, based on first order reliability methods (FORM); and
- a practical design format calculation, based on partial safety factors and taking into account characteristic values for action effects and response capacities.

For practical purposes, an exact evaluation of the failure probability is not feasible. Also, the FORM approximations are too cumbersome for everyday design, but may be applied in special cases. For normal design, the practical design formats have to be used.

The procedure for a reliability-based structural fire engineering design, related to a FORM approximation and a practical design format calculation, is illustrated by flow diagrams in Figures 4 and 6, respectively. For generality, the procedure is demonstrated for a load-bearing structure of charring material, for instance, a timber structure<sup>[39], [59]</sup>.

#### 3.1 Structural fire engineering design based on FORM approximation

Following the flow diagram in Figure 4 for a structural fire engineering design, based on a FORM approximation, the characteristics of the fire load and fire compartment constitute the basis for determining the fire exposure, expressed by the gas temperature or the heat flow to the structure as a function of time and either computed by solving the energy and mass balance equations of the compartment fire or chosen from some systematized design basis.

Together with construction data of the structure and information on the thermal, moisture mechanics and combustion properties of the structural material at elevated temperatures, the fire exposure gives the reduced cross-section of the structure and the associated transient temperature and moisture conditions. With the mechanical properties of the structural material as further input data, the transient temperature and moisture states for the uncharred part of the cross-section then has to be transferred to the time variation of the load-bearing capacity of the structure during the fire exposure, expressed, for instance, as the bending moment  $M_R(t)$  in a decisive section. The load, statistically representative for the fire situation, gives a maximum load effect with a bending moment  $M_S(t)$  in the section for the load-bearing capacity  $M_R(t)$ .

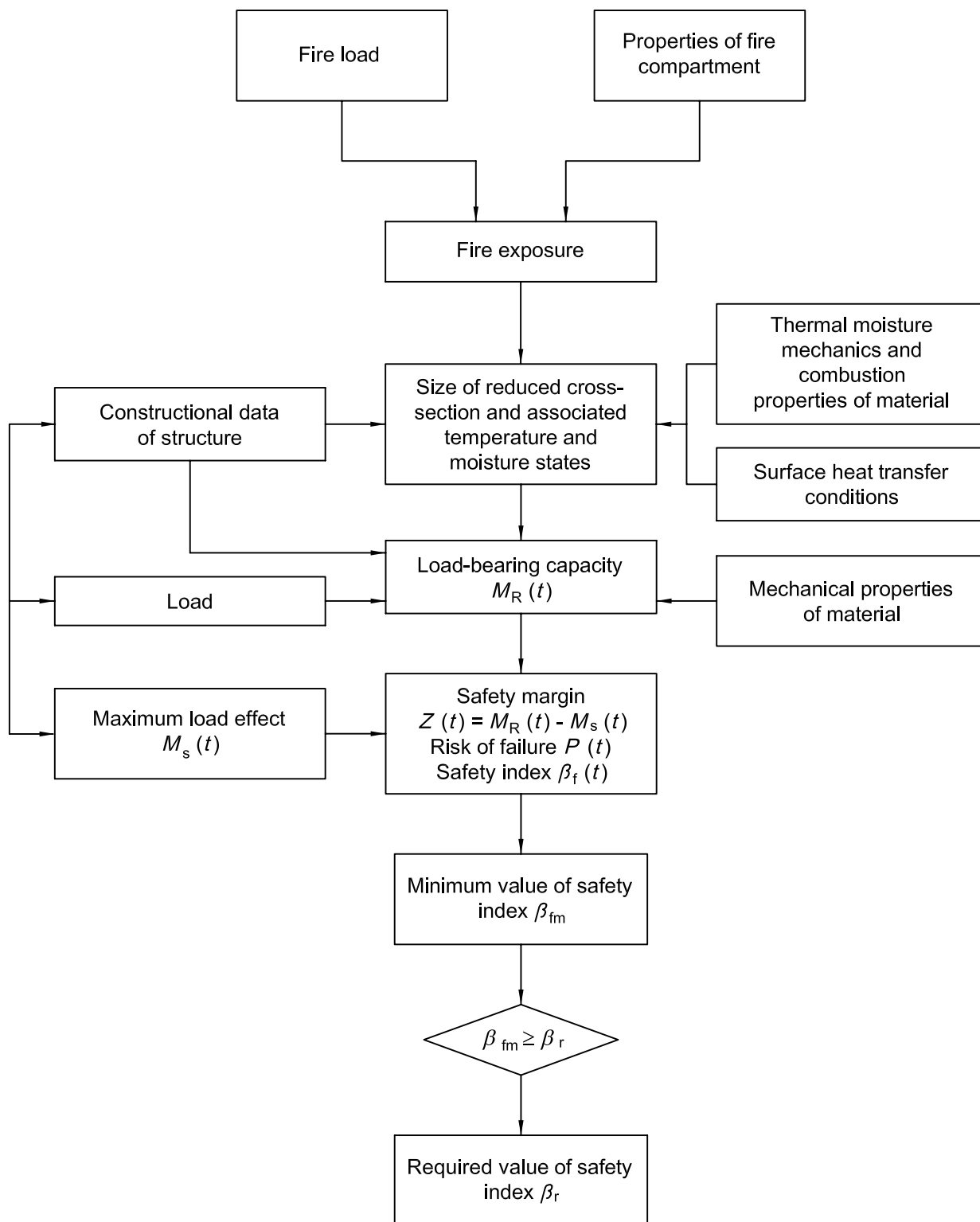

Figure 4 — Structural fire engineering design, based on first order reliability method (FORM)



The quantities  $M_R(t)$  and  $M_S(t)$  define the safety margin  $Z(t)$ , as

$$Z(t) = M_R(t) - M_S(t) \quad (10)$$

The related failure probability  $P(t)$  and the safety index  $\beta_f(t)$ , defined as the quotient between the average safety margin and the standard deviation, can then be calculated by the formulae:

$$P(t) = \int_{-\infty}^0 f_Z[Z(t)]dZ \quad (11)$$

$$\beta_f(t) = \varphi^{-1} [1 - P(t)] \quad (12)$$

where

$f_Z[Z(t)]$  is the probability density function of the safety margin  $Z(t)$ ;

$\varphi^{-1}$  is the inverse of the standardized normal distribution.

The design criterion implies that the minimum value of the safety index for the structure during the relevant fire exposure  $\beta_{fm} = [\beta_f(t)]_{\min}$  shall meet the required value of the safety index  $\beta_r$ , i.e.

$$\beta_{fm} - \beta_r \geq 0 \quad (13)$$

At the determination of the safety margin  $Z(t)$ , the failure probability  $P(t)$ , and the safety index  $\beta_f(t)$ , the following uncertainties have to be taken into account:

- the uncertainty in specifying the loading and of the model for calculating the load effect on the structure;
- the uncertainty in specifying the fire load and the characteristics of the fire compartment;
- the uncertainty in specifying the design data of the structure and the thermal, moisture mechanics, combustion, and mechanical properties of the structural material; and
- the uncertainty of the analytical models for calculating the compartment fire and the related heat transfer to the structure, the size of reduced cross-section and the associated temperature and moisture states, and the load-bearing capacity of the structure.

The required value of the safety index  $\beta_r$  depends on the probability of occurrence of a fully developed compartment fire  $p_1$ ; the reduction of this probability due to fire-fighting by the fire brigade  $p_2$  and to the effect of an installed fire extinguishment system  $p_3$ , if any; and the consequences of a structural failure. For the detailed technique of deriving required values of the safety index  $\beta_r$ , see for instance references [1], [2] and [60] to [62]. Example values of  $p_1$ ,  $p_2$  and  $p_3$  are given in references [1], [2] and [63].

In Figure 5, example values of  $\beta_r$  are for industrial buildings and a safety class, representative of the main load-bearing structure and separating structures bounding the fire compartment. The  $\beta_r$  values are given as a function of the floor area of the fire compartment  $A_f$  and the probability of occurrence of a fully developed compartment fire per year and unit area  $p = p_1 p_2 p_3$ .

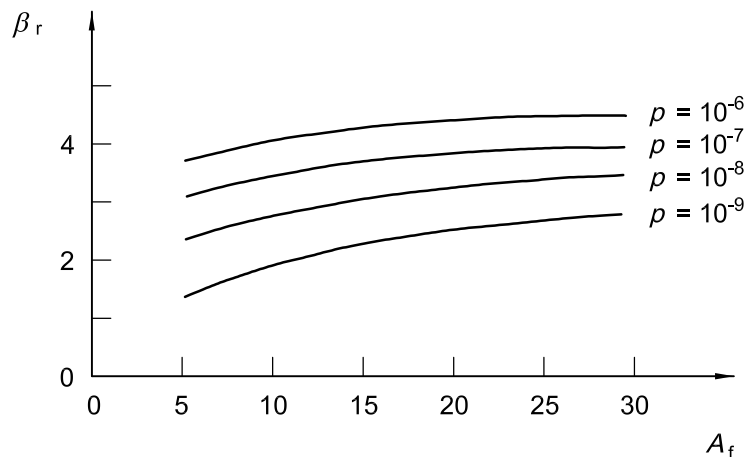

**Key**

- $A_f$  compartment floor area,  $10^3 \text{ m}^2$
- $\beta_r$  required value of the safety index

**Figure 5 — Example values of  $\beta_r$  as function of fire compartment floor area  $A_f$  and probability  $p$  of occurrence of a fully developed compartment fire**

**3.2 Structural fire engineering design based on practical design format**

As mentioned, for normal applications of a reliability-based structural fire engineering design, the practical design format has to be used and the flow diagram in Figure 6 illustrates the procedure for such a design.

For a load-bearing structure, the design format condition implies that the design minimum value of the load-bearing capacity  $R_d(t)$  during the fire exposure shall meet the design load effect on the structure  $S_d$ , i.e.

$$R_d = [R_d(t)]_{\min} \geq S_d \tag{14}$$

The condition must be fulfilled for all relevant types of failure. For a separating structure, the design format condition comprises requirements with respect to insulation and integrity. The insulation condition then implies that the design maximum value of the temperature on the unexposed side of the structure  $T_{sd}(t)$  during the fire exposure shall meet the temperature  $T_{cr}$ , acceptable with respect to the requirement to prevent a fire spread from the fire compartment to an adjacent compartment, i.e.

$$T_{sd} = [T_{sd}(t)]_{\max} \leq T_{cr} \tag{15}$$

For the integrity requirement, there is no analytically expressed design format condition available. Consequently, this condition has to be proved experimentally, when decisive.

In the practical design format, the probabilistic influences are considered by specifying characteristic values, expressed as a specified fractile, and related partial safety factors for the fire load, such structural design data as imperfections, the thermal material properties, the mechanical material properties and the loading. In deriving the partial safety factors, all uncertainties listed above in connection with the presentation of the design based on FORM approximations have to be included.

The functional requirements specified for the design should be differentiated with respect to type of occupancy, type and size of building, number of floors, size and location of fire compartment, and the importance of the structure or structural element to the overall stability of the building. This may be considered by a system of safety classes associated with different failure probabilities, the probability of the occurrence of a fully developed compartment fire included. In design verification, this safety differentiation is accounted for by applying different partial safety factors for different safety classes or by applying corresponding safety differentiation factors  $\gamma_{n1}$ .

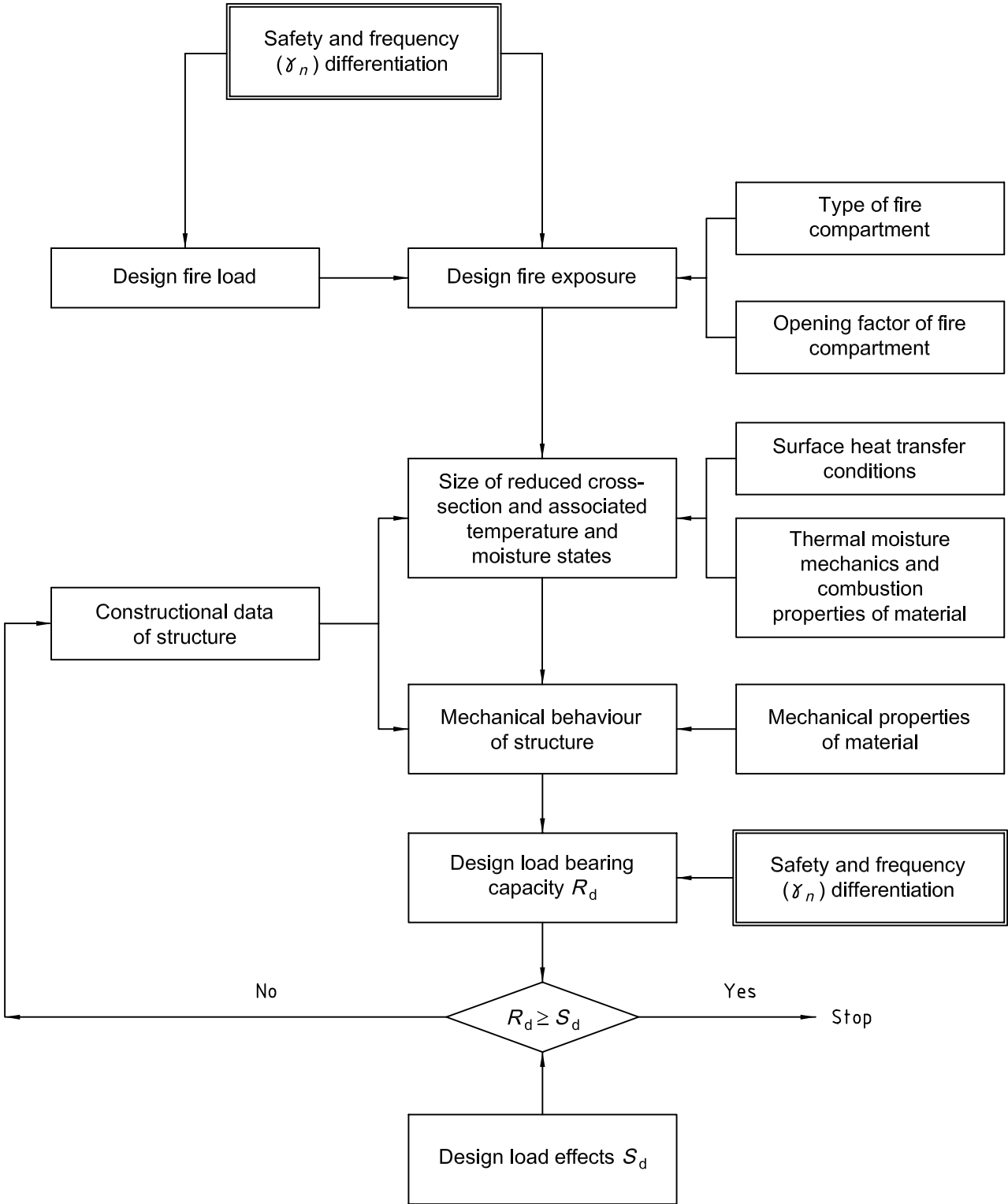

Figure 6 — Structural fire engineering design, based on partial safety factors (practical design format)

For a certain occupancy, provisions employed for reducing the frequency of a fully developed fire for a particular project, i.e.

- available force of fire brigades, and
- approved alarm and sprinkler systems

should be considered. In design verification, this frequency differentiation is accounted for by applying different partial safety factors, depending on employed provisions and fire compartment size, or by applying corresponding frequency differentiation factors  $\gamma_{n2}$ .

Summing up, the design format condition to be verified for a load-bearing structure reads:

$$R_{dn} = \frac{1}{\gamma_n} R_d (R_{d1}, R_{d2}, \dots) \geq S_d (G_d, Q_{d1}, \dots)$$

or

$$\frac{1}{\gamma_n} R_d (R_{k1}/\gamma_{r1}, R_{k2}/\gamma_{r2}, \dots) \geq S_d (G_k, \psi_i Q_{k,i}, Q_{k,ind}) \quad (16)$$

where

$R_d$  is the design value of the ultimate load-bearing capacity, determined by its lowest value during the relevant fire exposure;

$R_{di}, R_{ki}, \gamma_{ri}$  are design values, characteristic values and partial safety factors, respectively, related to the ultimate load-bearing capacity and accounting for the uncertainties in heat exposure and thermal and mechanical response, see Figure 6;

$S_d$  is the design load effect subject to fire, determined by considering an accidental load combination of the form

$$G_k + \sum_i \psi_i Q_{k,i} + Q_{k,ind} \quad (17)$$

where all actions, permanent loads (actions)  $G_k$ , variable loads (actions)  $Q_{k,i}$  and indirect actions due to fire exposure  $Q_{k,ind}$ , are given by their characteristic values;  $\psi_i$  are combination coefficients, generally different for  $i = 1$  and  $i > 1$ , and all other load factors are set to unity<sup>[2], [3]</sup>;

$\gamma_n$  ( $= \gamma_{n1}\gamma_{n2}$ ) is a safety and frequency differentiation factor, accounting for different safety classes ( $\gamma_{n1}$ ) and active fire protection measures ( $\gamma_{n2}$ ).

In Equation (16), the safety and frequency differentiation factor  $\gamma_n$  has been allocated to the design load-bearing capacity  $R_d$ . Alternatively,  $\gamma_n$  may be applied to affect the design fire load, thus modifying the design fire exposure, as shown in Figure 6.

Methods for the determination of values of the partial safety factors  $\gamma_{ri}$  and the safety and frequency differentiation factor  $\gamma_n$  are presented in references [1], [2] and [62], in which example values of the factors are also given. Factor values for practical design are also specified in the Eurocodes<sup>[3] to [9]</sup>, and in reference [44].

#### 4 Predictive model capabilities: uncertainties of design components [56]

The rapid progress in analytical and computer modelling of phenomena and processes of importance for a fire engineering design underscores the need for internationally **standardized procedures for evaluating the predictive capabilities of the models and for documenting the computer software**. Two ASTM Standard Guides<sup>[64], [65]</sup> contribute to this task.

An evaluation of the model capabilities is critical in establishing both the applicability and limitations of the models for a specific use. The process recommended in the Standard Guide<sup>[64]</sup>:

- includes a brief description of the model and the scenario for which evaluation is sought;
- presents methodologies for conducting an analysis to quantify the sensitivity of model predictions to various uncertainty factors;
- provides several alternatives for evaluating the accuracy of the predictions of the model; and
- gives guidance on the relevant documentation required to summarize the evaluation process.

A documentation of the computer software is necessary to ensure that users can judge the adequacy of the scientific and technical basis for the models, select the appropriate computer operating environment, and use the software effectively within the specified limitations. Adequate documentation also will help to prevent unintentional misuse of the computer software. The guidelines in reference [65] are presented in terms of three types of documentation:

- a) technical document,
- b) user's manual, and
- c) installation, maintenance, and programming manual.

Systematic studies of the predictive capabilities of models and related computer software, used for describing the simulated fire exposure and the thermal and mechanical behaviour of fire-exposed structures, are still rare in the literature. A few such studies, carried out and reported during the last few years, however, seem to indicate that the situation is now going to improve. Compartment fire modelling is dealt with in references [66] to [68] and modelling of the thermal and mechanical behaviour of structures subject to fire in references [69] and [70]. In references [66] and [68], general categories are identified regarding possible sources of error in using a computer model to predict the value of a state-variable such as temperature or heat flux. The categories specified are

- unreality of the theoretical and numerical assumptions in the model,
- errors in the numerical solution techniques,
- software errors,
- hardware faults, and
- application errors.

The report<sup>[67]</sup> specifies for ten zone models and three field models for the compartment fire degree of validation, limitations, restrictions on compartment size, number of vents and number of fuels that can be accommodated, and number of organizations using the model. Useful conclusions are drawn with respect to input/output data, experience of using the models, model validation, and potential limitations. The survey, presented in reference [69], discusses the theoretical background of seven thermal and 14 structural behaviour, fire-dedicated, computer programs, together with their strengths and weaknesses. The differences between the programs were found to lie mainly in the material models adopted, the material data input, the user-friendliness and documentation of the software. The majority of available fire-dedicated structural

programs still require significant development, and as most of them are not user-friendly or properly documented, using them effectively and universally would be very difficult.

Applied to fire-exposed steel columns, reference [70] reports comparative calculations of the structural behaviour by five computer programs. In terms of the ultimate resistance of the columns, the calculated results are very similar, with a maximum difference between two programs of 6 %. Greater differences are observed for the displacements of the columns, probably due to different ways of considering the residual stresses at increasing temperature in the programs. When evaluating the results, it is important to note that the same mechanical behaviour model for steel at transient elevated temperatures, the model described in reference [5], was used in all computer programs.

Very few **sensitivity and uncertainty studies** relevant to structural fire design are reported in the literature. The most comprehensive study is probably still the one presented by Magnusson twenty years ago<sup>[32], [58], [71]</sup>. The methodology developed for this study is quite general and applicable to a wide class of structures and structural elements. To get applicable and efficient final safety measures, the probabilistic analysis is numerically exemplified for an insulated, simply supported steel beam of I-cross-section as a part of a floor or roof assembly. The chosen statistics of dead and live load and fire load are representative for office buildings.

With the basic data variables selected, the different uncertainty sources in the design procedure were identified and dissembled in such a way that available information from laboratory tests could be utilized as profitably as possible. The derivation of the total or system variance  $\text{Var}(R)$  in the load-bearing capacity  $R$  was divided into two main stages:

- variability  $\text{Var}(T_{\max})$  in maximal steel temperature  $T_{\max}$  for a given type of structure and a given design fire compartment, and
- variability in strength theory and material properties for known value of  $T_{\max}$ .

The results obtained are illustrated in Figure 7, giving the decomposition of the total variance in maximum steel temperature  $T_{\max}$  into the component variances as a function of the insulation parameter  $\kappa_n$ :

$$\kappa_n = A_i k_i / (V_s d_i)$$

where

$A_i$  is the interior surface area of the insulation per unit length;

$d_i$  is the thickness of the insulation;

$k_i$  is the thermal conductivity of the insulating material, corresponding to an average value for the whole process to fire exposure;

$V_s$  is the volume of the steel structure per unit length.

Increasing  $\kappa_n$  expresses a decreased insulation capacity.

The component variances refer to the stochastic character of the fire load density  $q$ , the uncertainty in the insulation properties  $\kappa$ , the uncertainty reflecting the prediction error in the theory of compartment fires and heat transfer from the fire process to the structural member  $\Delta T_2$ , and a correction term reflecting the difference between a natural fire in a laboratory and under real life service conditions  $\Delta T_3$ . Analogously, Figure 8 exemplifies the decomposition of the total variance in the load-bearing capacity  $R$  into component variances as a function of the insulation parameter  $\kappa_n$ . The component variances refer to the variability in the maximum steel temperature  $T_{\max}$ , variability in material strength  $M$ , the uncertainty reflecting the prediction error in the strength theory  $\Delta \Phi_1$ , and the uncertainty due to the difference between laboratory tests and *in situ* fire exposure  $\Delta \Phi_2$ .

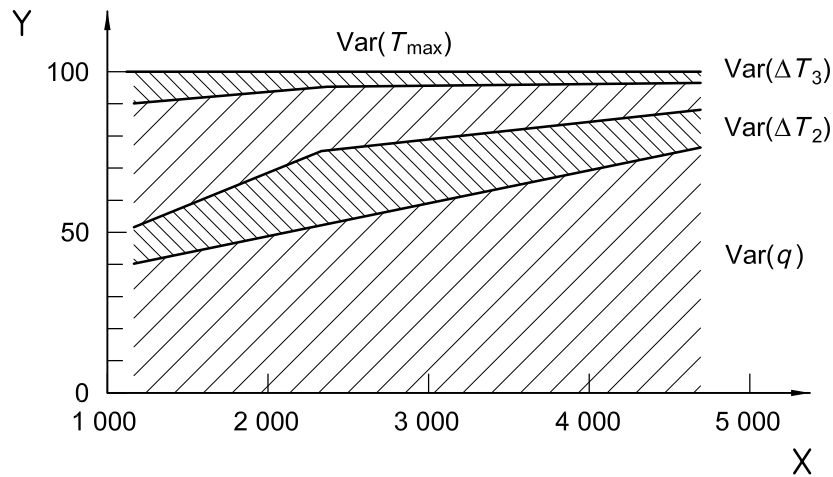

**Key**

X  $\kappa_n$ ,  $W \cdot m^{-3} \cdot ^\circ C^{-1}$

Y total variance in maximum steel temperature, %

**Figure 7 — Separation of total variance in maximum steel temperature  $T_{max}$  into component variances as function of insulation parameter  $\kappa_n$**

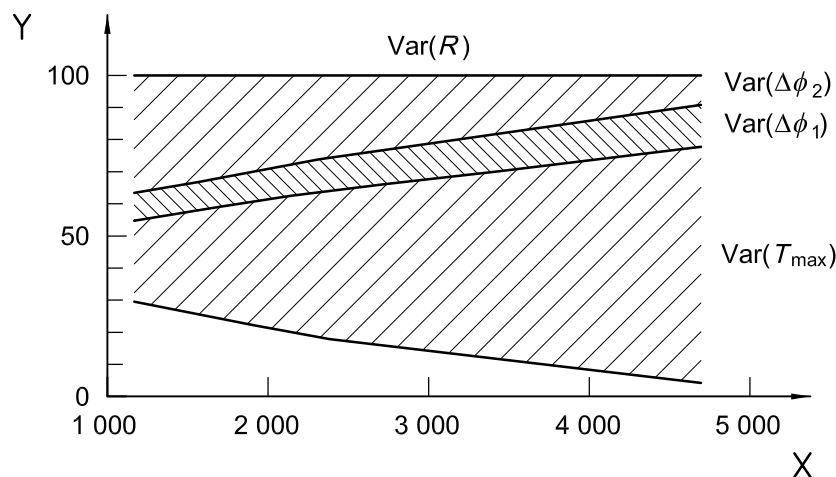

**Key**

X  $\kappa_n$ ,  $W \cdot m^{-3} \cdot ^\circ C^{-1}$

Y total variance in the load-bearing capacity, %

**Figure 8 — Separation of total variance in load-bearing capacity  $R$  into component variances as function of insulation parameter  $\kappa_n$**

Uncertainty studies of fire-exposed concrete structures are scarce. Results from one of the few studies are shown in Figure 9 [72], which illustrates the breakdown of the total variance in fire resistance or load-bearing capacity into component variances as a function of the slenderness ratio  $\lambda$  for an eccentrically compressed, reinforced concrete column. The component variances are related to the following stochastic variables:  $f_c$  = compressive strength of concrete at ordinary room temperature,  $f_s$  = strength of reinforcement at ordinary room temperature,  $b$  = width of the cross-section,  $h$  = height of the cross-section,  $x_t$  = position of tensile reinforcement,  $x_c$  = position of compressive reinforcement,  $f_{s,T}$  = yield stress of steel as a function of temperature  $T$ , and  $k_c$  = thermal conductivity of concrete.

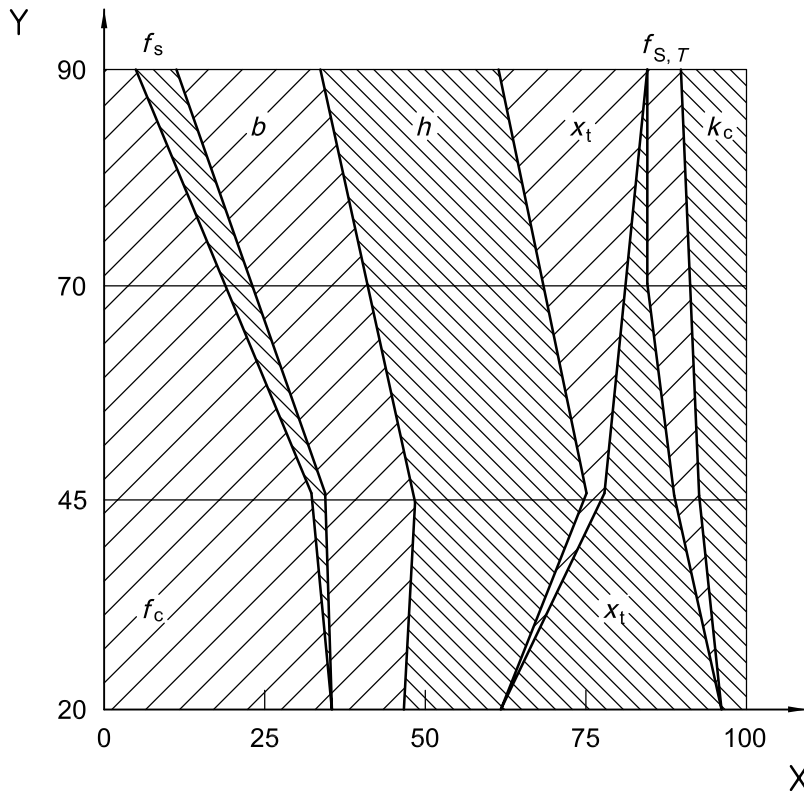

**Key**

X total variance in fire resistance, %  
 Y  $\lambda$  slenderness ratio

Concrete B25, percentage of reinforcement  $\mu = 0,2 \%$ ,  $b = h = 30$  cm, eccentricity  $e = 0,2 h$

**Figure 9 — Separation of total variance in resistance or load-bearing capacity  $R$  into component variances as a function of slenderness ratio  $\lambda$  for an eccentrically compressed, reinforced concrete column**

A supplementary illustration of results of sensitivity studies regarding a fire engineering design of timber structures is shown in Figure 10 [73]. The study deals with the sensitivity of the charcoal layer penetration for a fire-exposed timber structure as a function of certain material input data in a defined simulation model. Figure 10 gives the influence of varying the thermal conductivity of the charcoal and the rate of surface reaction.

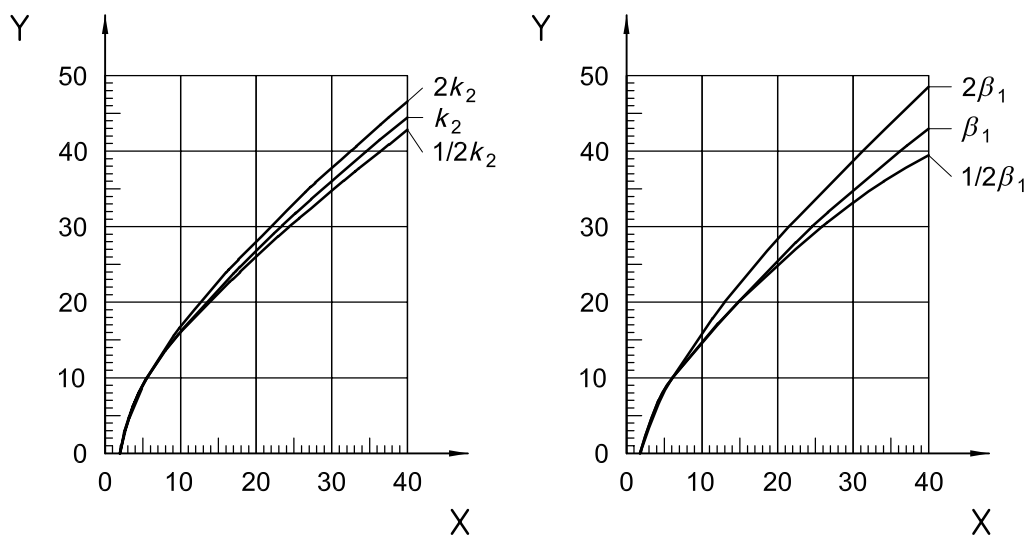

**Key**

X time, min  
 Y depth, mm

**Figure 10 — Depth of charring as function of time for variable thermal conductivity  $k_2$  of charcoal and variable rate of surface reaction  $\beta_1$**



A first order reliability analysis (FORM) of fire-exposed wood joist assemblies is presented in reference [74]. By using non-linear least-square regression analysis on 42 full scale tests, a time-to-failure model is developed, predicting the deterministic value of the resistance of the assembly. The exposure parameter is defined in the paper as the duration of the ventilation-controlled compartment fire predicted by the fire load, and the window area and height, assuming constant rate of burning. Equations describing the total system and component variances are developed which, when quantified, lead to a determination of the safety index  $\beta$ .

With expanding knowledge on parameter and component uncertainties, the qualifications increase for a structural fire engineering design based on the principles of cost-benefit optimization<sup>[1]</sup>. Minimizing the total cost for a fully developed or post flashover compartment fire and its expected consequences, then determines the optimum failure probability or target probability.

The total cost  $C_{\text{tot}}$  can be written as

$$C_{\text{tot}} = C_p + [C_{\text{fo}} + \Delta C \times P_{(\text{fail/fo})}] P_{(\text{fo})} \quad (18)$$

where  $C_p$  is the cost of the passive fire protection measures,  $C_{\text{fo}}$  the direct losses due to flashover without failure of the load-bearing structure,  $\Delta C$  the additional expected cost due to failure,  $P_{(\text{fo})}$  the probability of flashover, and  $P_{(\text{fail/fo})}$  the failure probability on the condition of flashover.

Assume that  $x$  is some passive fire protection parameter (for instance, the thickness of an insulation of a steel structure), which affects the failure probability but not the flashover probability. Minimizing the total cost  $C_{\text{tot}}$  then gives the equation

$$\frac{\delta C_{\text{tot}}}{\delta x} = \frac{\delta C_p}{\delta x} + \Delta C \frac{\delta P_{(\text{fail/fo})}}{\delta x} P_{(\text{fo})} = 0 \quad (19)$$

from which the optimum failure probability  $P_{(\text{fail/fo})\text{opt}}$  can be determined.

A condition for the described optimization approach is that people can evacuate safely from the burning building. This requires a design evacuation time that is less than the expected time of the building's failure.

## 5 Main components of structural fire engineering design

The flow diagrams in Figures 4 and 6 for a rational fire engineering design of load-bearing structures identify three main components, namely

- design fire exposure,
- thermal material properties and transient temperature state, and
- mechanical material properties and structural behaviour.

These components will be addressed briefly with regard to the present state of knowledge, focusing on the material properties to be used as basic input data.

### 5.1 Design fire exposure

The fully developed compartment fire, which is the decisive part of a fire for the thermal and mechanical behaviour of load-bearing and separating structures in buildings, has been subjected to comprehensive studies for a very long time. During the past 30 years, several analytical models, simulating real fires, have been presented. In a review paper<sup>[75]</sup>, published 12 years ago, 14 such models were classified on the basis of 14 principal modelling aspects. The models included either represent important steps in the evolution of knowledge or offer unique concepts.

The fundamental characteristics for a complete description of the fully developed compartment fire are the time variations of the

- a) gas temperature,
- b) geometrical and thermal data for external flames,
- c) smoke and its optical properties, and
- d) composition of the combustion products, particularly toxic and corrosive gases.

The simulation models, developed for structural fire purposes, concentrate on the characteristics a) and b). Most models are partly theoretically- and partly empirically-based, with the empirical part focusing on data on the rate at which the fuel is consumed.

For known combustion characteristics of the fire load, the time curve of the gas temperature in the fire compartment or the heat flux to an exposed structure can be calculated in the individual practical application from the energy and mass balance equations of the compartment fire<sup>[76] to [89]</sup>.

The energy balance equation shown in Figure 11 is:

$$\dot{h}_c = \dot{h}_e + \dot{h}_r + \dot{h}_w + \dot{h}_g \quad (20)$$

where

$\dot{h}_c$  is the rate of heat release due to the combustion of the fuel (fire load);

$\dot{h}_e$  is the energy removed per unit time by change of hot gases against cold air;

$\dot{h}_r$  is the energy removed per unit time by radiation through the openings;

$\dot{h}_w$  is the energy removed per unit time by heat transfer to the enclosing structures;

$\dot{h}_g$  is the energy stored per unit time within the fire compartment; usually negligible.

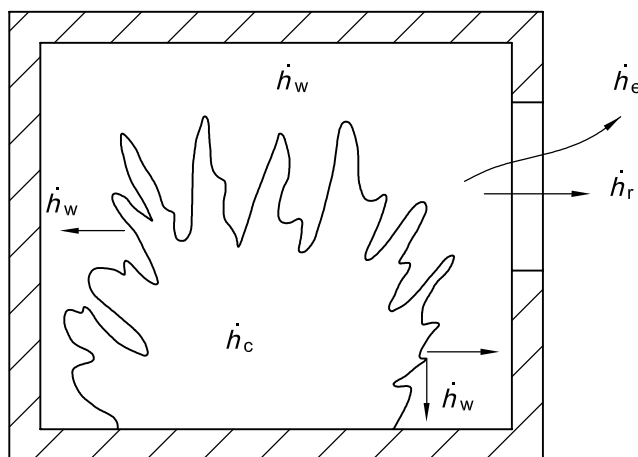

**Figure 11 — Energy balance of a compartment fire**

The corresponding mass balance is described by the equation

$$\dot{m}_f = \dot{m}_{\text{air}} + \dot{m}_p \quad (21)$$

where

$\dot{m}_f$  is the mass outflow of hot gases;

$\dot{m}_{air}$  is the mass inflow of air;

$\dot{m}_p$  is the rate of fuel pyrolysis.

To simplify, fully developed compartment fires can be described by two types of behaviour, either ventilation-controlled or fuel bed-controlled<sup>[90]</sup>. For the first type, the combustion during the active stage of the fire is controlled by the ventilation of the compartment with the burning rate approximately proportional to the air supply through the openings and does not depend on the amount, porosity and particle shape of the fuel in any decisive way. For the second type, the combustion is mainly controlled by the properties of the fuel and is fairly independent of the air supply through the openings. The boundary between the two types of fire behaviour is not clearly defined.

Figure 12 illustrates the two types of compartment fires in a diagram, giving the rate of enthalpy release during the fire process versus time for two types of fuel<sup>[80]</sup>. In the figure,  $\dot{h}_p$  denotes the potential rate of change of enthalpy of the gas, pyrolyzed from the fuel, i.e. the maximum enthalpy release rate that would occur under ideal burning conditions, given by the relationship

$$\dot{h}_p = \dot{m}_p H \quad [\text{J} \cdot \text{s}^{-1}] \quad (22)$$

where

$\dot{m}_p$  is the rate of fuel pyrolysis, in  $\text{kg} \cdot \text{s}^{-1}$ ;

$H$  is the net calorific value of fuel, in  $\text{J} \cdot \text{kg}^{-1}$ .

The term  $\dot{h}_s$  denotes the rate of heat release for stoichiometric combustion of the air inflow, determined by the formula

$$\dot{h}_s = \dot{m}_{air}(H/r) \quad [\text{J} \cdot \text{s}^{-1}] \quad (23)$$

where

$\dot{m}_{air}$  is the mass inflow of air, in  $\text{kg} \cdot \text{s}^{-1}$ ;

$r$  is the air/fuel mass ratio, i.e. the amount of air needed to perfectly burn a unit mass of fuel.

For a given compartment,  $\dot{h}_s$  is primarily a function of the ventilation factor  $A\sqrt{h}$ , where  $A$  is the area and  $h$  the height of the opening of the compartment, and the gas temperature and only slightly dependent on the fuel properties. The combustion enthalpy, developed per unit mass of air,  $H/r$  is approximately independent of the type of fuel. Consequently,  $\dot{h}_s$  does not vary greatly for different fuels burned in the same compartment.

The actual enthalpy release rate  $\dot{h}_c$  will be the lesser of  $\dot{h}_p$  and  $\dot{h}_s$ , reduced by a factor of maximum combustion efficiency  $b_p$ , which corrects for incomplete mixing, i.e.

$$\dot{h}_c = \text{lesser of} \begin{cases} \dot{h}_p b_p \\ \dot{h}_s b_p \end{cases} \quad (24)$$

Figure 12 shows two compartment fires with  $\dot{h}_p > \dot{h}_s$  at flashover, which means that the fires start as ventilation-controlled. At a decreasing rate of pyrolysis during the fire, the  $\dot{h}_p$  curve may cross the  $\dot{h}_s$  curve after some time. At this point, the fire changes to be fuel controlled from then on. For  $\dot{h}_p > \dot{h}_s$ , more fuel is

pyrolyzed within the fire compartment than can be burnt inside it. The difference,  $\dot{h}_p - \dot{h}_s$ , shown hatched in the fire for the wood fuel fire, represents the excess pyrolyzates, released from the compartment. For fuels with a high rate of pyrolysis, which is typical for flammable liquids and many plastic fuels, these excess pyrolyzates can give rise to a considerable fire hazard outside the fire compartment, for instance, in corridors or at facades.

The practical use of the energy and mass balance equations of the fully developed compartment fire for design purposes requires access to well-documented computer programs. There are basically three such computer codes available that are adapted for engineering applications, namely SFIRE<sup>[78]</sup>, [86], COMPF-2<sup>[82]</sup> and BRAND<sup>[83]</sup>. A closed-form approximation, arranged to suit hand calculations, is presented in reference [84].

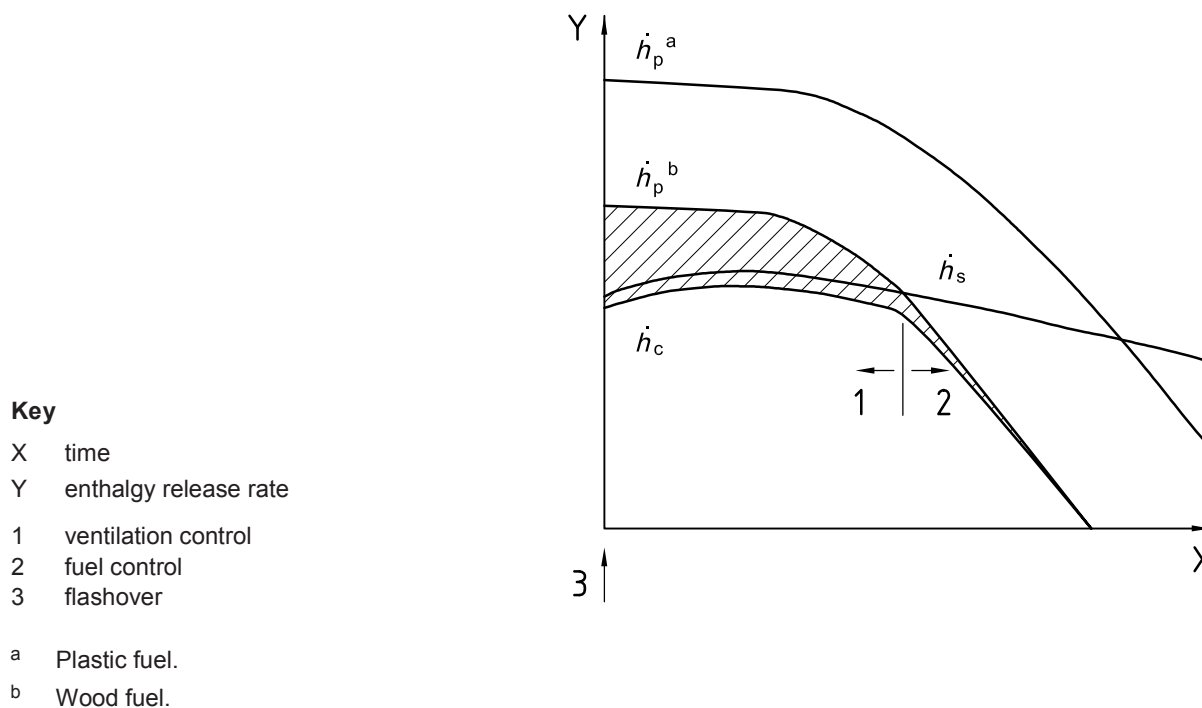

**Figure 12 — Possible rates of enthalpy release in a fully developed compartment fire versus time for two types of fuel**

If reasonably correct input data are used, the computer programs quoted have the ability to simulate real fires with practically acceptable accuracy in compartments of moderate size, i.e. compartments with a size representative of dwellings, ordinary offices, schools, hospitals, hotels and libraries. For these types of applications, systematized design bases are available, derived by the computer programs and essentially facilitating a fire engineering design of load-bearing and separating structures. The internationally most frequently referred design basis is the set of gas temperature-time curves as a function of the fire load, opening factor of the compartment and the thermal properties of the structures enclosing the compartment, which originates from early contributions by Magnusson-Thelandersson<sup>[78]</sup> (see Figure 13). The design basis was computed under the assumptions that:

- the combustion of the fire load takes place entirely within the fire compartment,
- the fire process is ventilation-controlled, and
- the gas temperature is uniform within the fire compartment at any time,

giving a conservative solution. The design basis has been officially approved by the Swedish authorities for practical application since 1976<sup>[91]</sup>.

Principally, the same design basis is included, as information, in Eurocode 1<sup>[3]</sup>. As further described in 2.1, the design basis is given more concisely in a parametric form according to reference [87].

A comparative study of the design bases according to Figure 13 and the parametric fire, as defined in Eurocode 1, and by Equations (5) to (8), is presented in reference [92]. For the heating phase of the compartment fire, the study verifies that the difference between the temperature-time curves of the two design bases increases with an increasing opening factor and decreasing time, but is not decisive for ordinary practical applications. For the decay phase of the compartment fire, the difference between the two approaches is substantial, as shown in Figure 14. The parametric fire underestimates the thermal exposure compared with the design basis according to Figure 13. Figure 14 also includes an alternative description of the decay phase, defined by the expression <sup>[44]</sup>

$$dT_t/dt^* = -800 e^{-0,9t_d^*} \quad [^{\circ}\text{C} \cdot \text{h}^{-1}] \quad (25)$$

in combination with Equation (7) for  $t_d^*$ , which gives a better agreement with the design basis, illustrated in Figure 13.

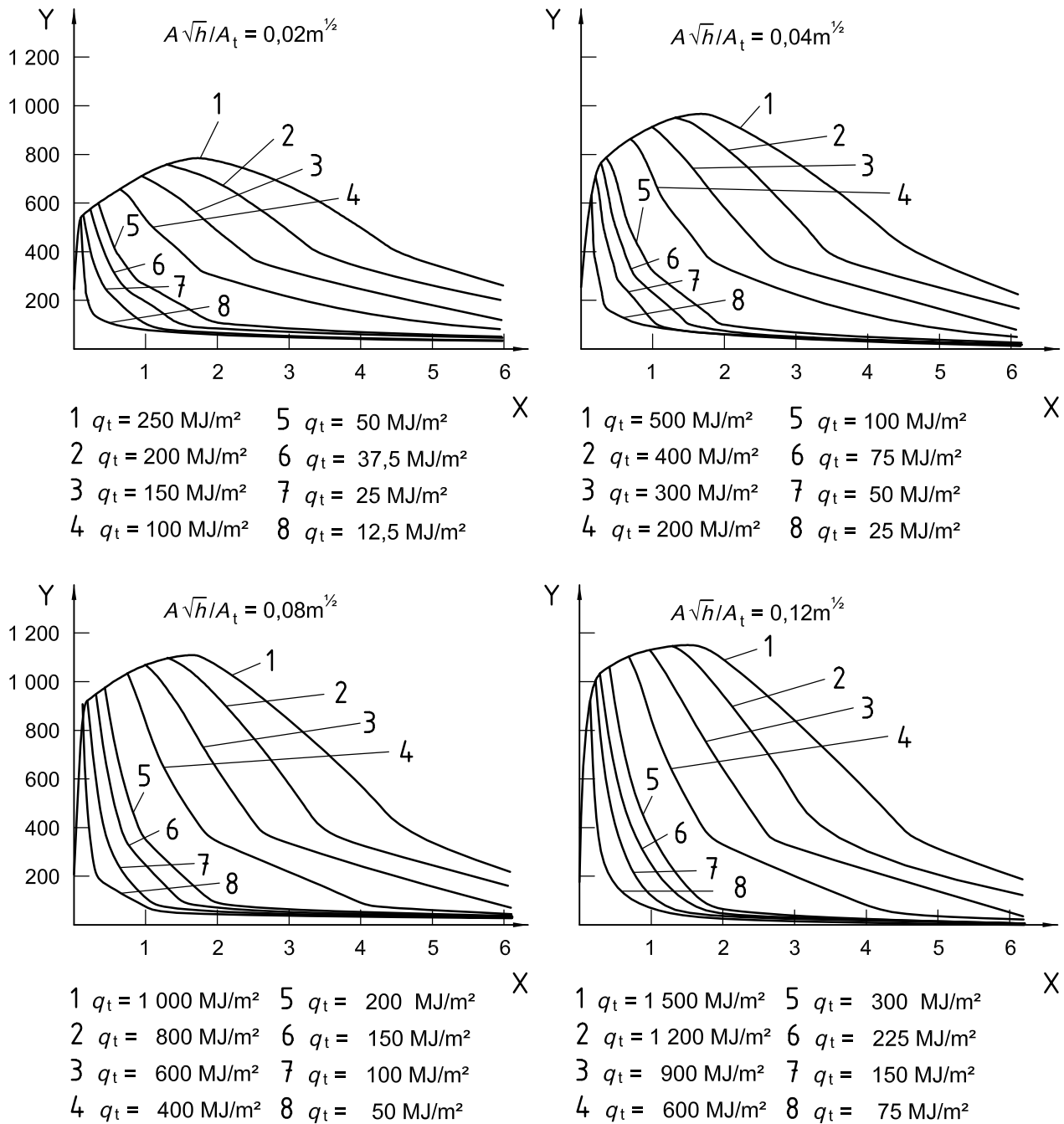

**Key**

- |   |                         |       |  |
|---|-------------------------|-------|--|
| X | time, h                 | A     | total area of window and door openings           |
| Y | temperature, $T_t$ , °C | h     | mean value of openings                           |
|   |                         | $A_t$ | total area of surfaces, bounding the compartment |

Curves indicate the values of  $q_t$ , in  $\text{MJ/m}^2$ .

NOTE 1 See Equations (5) to (9) for more detail concerning these parameters.

NOTE 2 By using fictitious values of fire load density and opening factor, the influence of thermal properties of bounding structures can be considered [18], [44], [78], [91].

**Figure 13 — Example of gas temperature versus time curves ( $T_t$  versus  $t$ ) of fully developed compartment fires as function of fire load density  $q_t$  per unit area of surfaces bounding the compartment and opening factor  $A\sqrt{h}/A_t$**

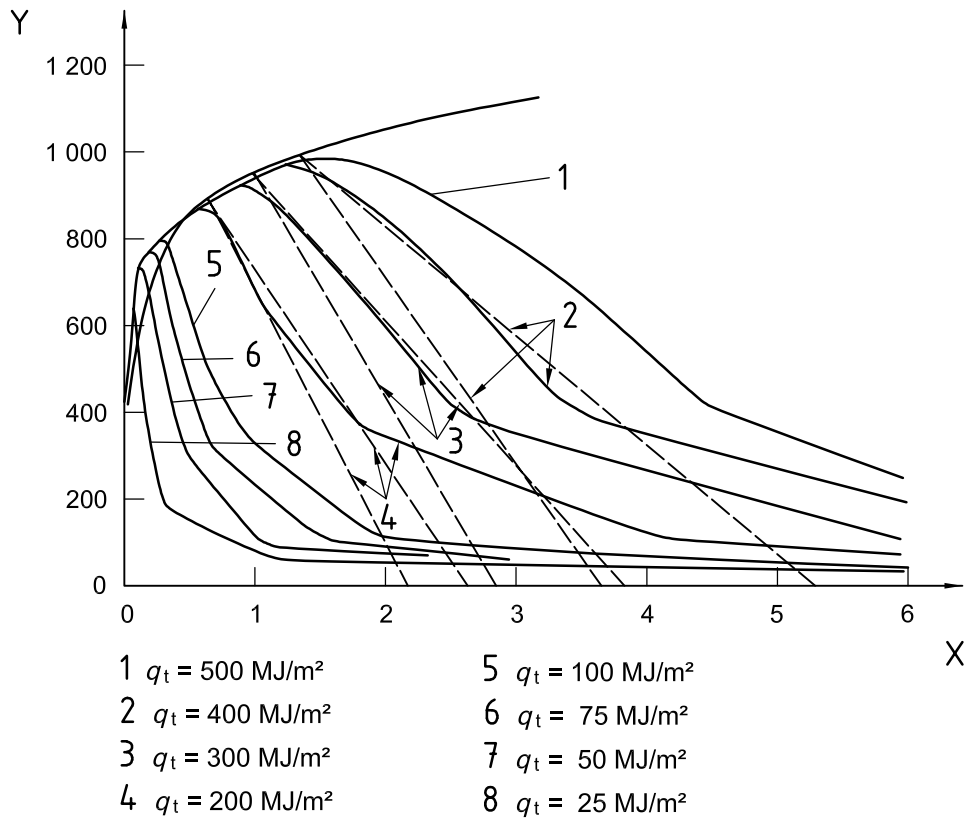

**Key**

X time, h  
 Y temperature,  $T_t$ , °C

**Figure 14 — The decay phase of the compartment fire**

Above specifying the compartment fire, Eurocode 1 also includes, as informative, a simplified method for the calculation of the thermal exposure on external structural members from flames emerging from window openings, based on references [93] and [94].

A main problem in applying these computer programs more accurately in the design is the incomplete information available on the rate of heat release due to the combustion of the fire load. Such information is, however, continuously being improved. During the last ten years, relevant data have been determined on such fire load components as upholstered furniture, solid furniture with flat extended surfaces, mattresses and beds, combustible lining materials, and paper stored in desks, filing cabinets or on shelves. Surveys of such data are given in references [86] and [95].

The importance of correct input data is illustrated in Figure 15, which shows calculated gas temperature versus time curves [Figure 15 b) for a specified fire load and compartment<sup>[86]</sup>. Curve (1) gives the gas temperature, computed with the assumption that only part of the energy content of the fire load is released inside the compartment during the fire. Curve (2) shows the corresponding curve based on the conservative assumption that all the energy content of the fire load is released inside the compartment.

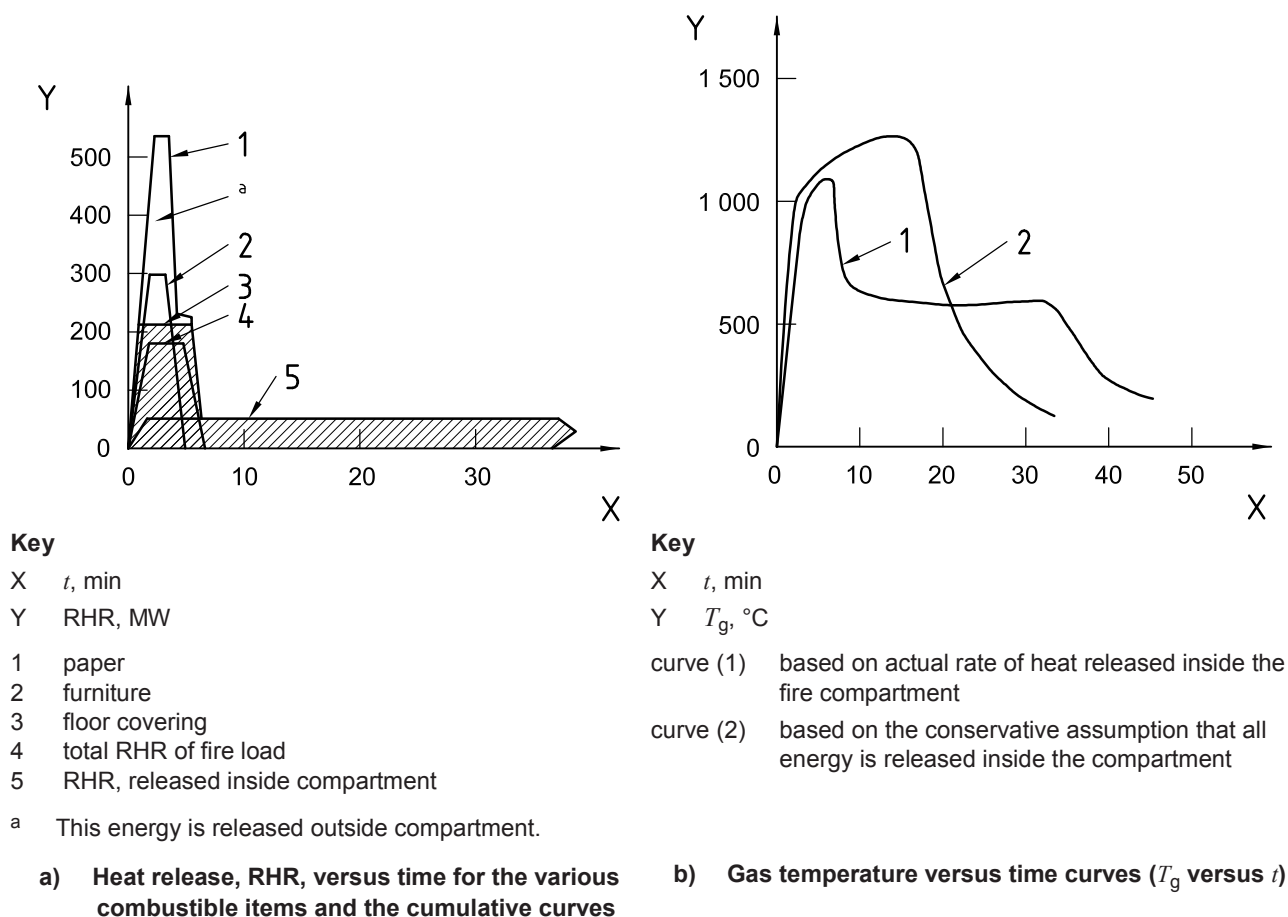

**Figure 15 — Curves showing gas temperature and heat release versus time for a fully developed compartment fire in an office space**

The fire behaviour of windows is significant for the ventilation of the fire compartment, and hence for the fire development. Fire engineering calculations are normally based on the assumption that given a fire, the window glass instantaneously disintegrates, providing the maximum ventilation area and opening factor of the enclosure. To improve the accuracy of the calculation, it is, however, important to have access to simulation models and criteria that can predict the behaviour of the window glass for different fire scenarios.

Windows break in fires due to thermal stress from the differential heating of the central portion and the shaded edge. Theories and experiments presented have given a critical temperature difference of 60 °C to 90 °C for edge-protected panes of ordinary glass qualities [96] to [98]. The critical values quoted cannot be generalized for application to other types of glasses and other ways of mounting the panes. A review of the current level of knowledge in literature on this phenomenon up to 1994 is presented in reference [99]. A glass heat transfer/fracture model, intended for direct implementation into zone-type computer fire codes, is developed in reference [100]. The analysis described is similar to the one presented in reference [101], but provides a more complete assessment of the radiation heat transfer.

For large compartments, as in industrial buildings and sports halls, the computer programs and related simplified design basis referred to do not give a satisfactory simulation of real fire exposure. As confirmed by experience, fires in such compartments will not frequently lead to flashover. The decisive fire exposure of the load-bearing and separating structures is caused by a fire, not fully comprising the whole compartment. The fire may locally expose a structural element, e.g. a beam, a column or a frame, more or less severely than would be the case, if the design is based on gas-temperature-versus-time curves of the fully developed compartment fire according to Figure 13 or on computer programs as SFIRE, COMPF-2 and BRAND. For large compartments, there are no simple simulation models of zone type available. The structural fire engineering design, therefore, has to be based on either more complex zone models<sup>[102], [103]</sup> or field models for the prediction of the fire exposure<sup>[104] to [107]</sup>.



## 5.2 Thermal material properties and transient temperature state

The transient heat flow within a fire-exposed structure is governed by the heat balance equilibrium equation, based on Fourier's law

$$\nabla^T(\lambda\nabla T) - \dot{e} + Q = 0 \quad (26)$$

$$e = \int_{T_0}^T \rho c_p dT + \sum_i l_i \quad (27)$$

$$\nabla = \begin{bmatrix} \frac{\delta}{\delta x} \\ \frac{\delta}{\delta y} \\ \frac{\delta}{\delta z} \end{bmatrix} \quad (28)$$

where

- $\nabla$  is the gradient operator;
- $\nabla^T$  is the transpose of  $\nabla$ ;
- $T$  is the temperature;
- $\lambda$  is the symmetric positive definite thermal conductivity matrix;
- $\dot{e}$  ( $= \delta e / \delta t$ ) is the rate of specific volumetric enthalpy change;
- $Q$  is the rate of internally generated heat per volume;
- $\rho$  is the density;
- $c_p$  is the specific heat;
- $l_i$  is the latent volumetric heat due to phase changes at various temperature levels;
- $x, y, z$  are the Cartesian coordinates;
- $t$  is the time.

Thus, the thermal material properties required for the transient thermal analysis are identified.

The solution of the heat-balance equilibrium equation, Equation (26), is complicated by the fact that the thermal conductivity matrix  $\lambda$  and the rate of specific volumetric enthalpy change  $\dot{e}$  depend on the temperature  $T$  to an extent that cannot be disregarded. Further complications arise when the material undergoes phase changes during the heating and when the material has initial moisture content.

In ordinary design, the influence of moisture is considered in a simplified way in calculating the transient temperature state of fire-exposed structures. It is assumed that all moisture evaporates, without any moisture transfer, at the temperature 100 °C or within a narrow temperature range, with the heat of evaporation giving a corresponding change in the enthalpy-temperature curve. The influence of phase changes is included in a similar way.

In reality, the moisture distribution changes continuously in the structure during fire exposure. Hence, in principle, it is not correct to include the effect of moisture content in the thermal properties. In a structure of moist material, the heat transfer is combined with a mass transfer and, from a strict thermodynamical point of

view, these two transport mechanisms should be analysed simultaneously by a system of inter-related partial differential equations.

In references [15] and [108], an accurate model and a related computer program are presented for the inter-related heat and mass transfer in fire-exposed timber structures. The model simulates the transient temperature and moisture states in both uncharred and charred parts of the cross-sections of the structure, as well as the growth of the charred layer in combination with its oxidation at the surface due to variable thermal exposure. Output data from the calculations are the cross-section profiles of temperature, moisture, pressure and density, and the penetration of the charcoal layer and mass loss as a function of time, as shown in Figure 16<sup>[15]</sup>. Material properties required are: the thermal conductivity of original wood and charcoal; the specific heat capacity of original wood, charcoal, volatile pyrolysis products and water vapour; the dynamic viscosity of volatile pyrolysis products and water vapour; the reaction rate and heat of reaction in the process of wood pyrolysis; and the heat of reaction at the oxidation of charcoal at the surface of the material. All properties must be specified as functions of temperature, and the density and permeability of original wood and charcoal.

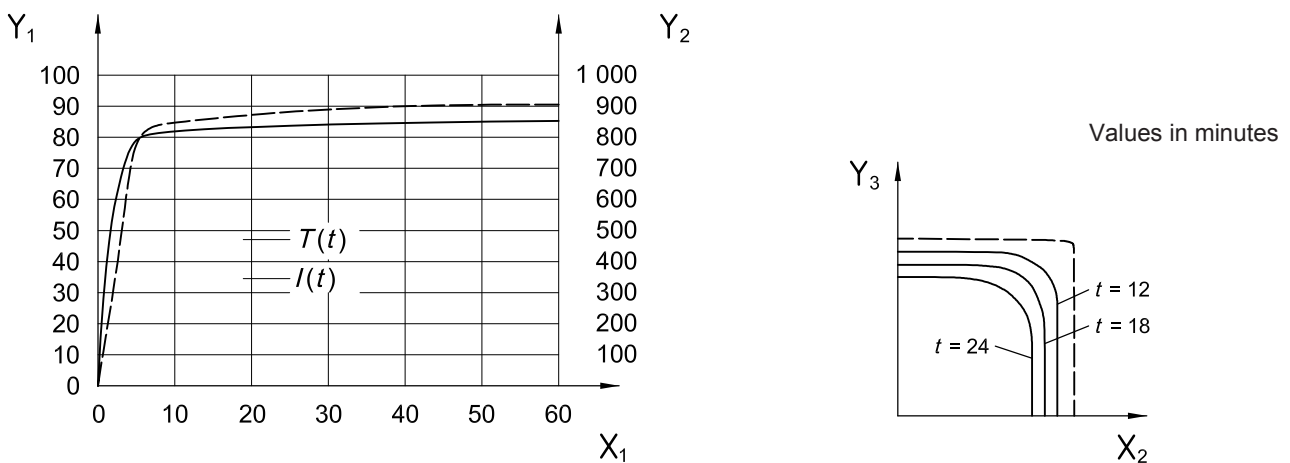

**Key**  
 $X_1$  time,  $t$ , min  
 $Y_1$  incident radiation  $I(t)$ , kW·m<sup>-2</sup>  
 $Y_2$  temperature,  $T_t$ , °C

**Key**  
 $X_2$  distance  $x$  from the cross-section centre  
 $Y_3$  distance  $y$  from the cross-section centre  
 ----- outer surface of wood cross-section

a) Incident radiation  $I(t)$  and the corresponding gas temperature-time curve  $T_t$

b) Depth of charring curves with respect to time,  $t$

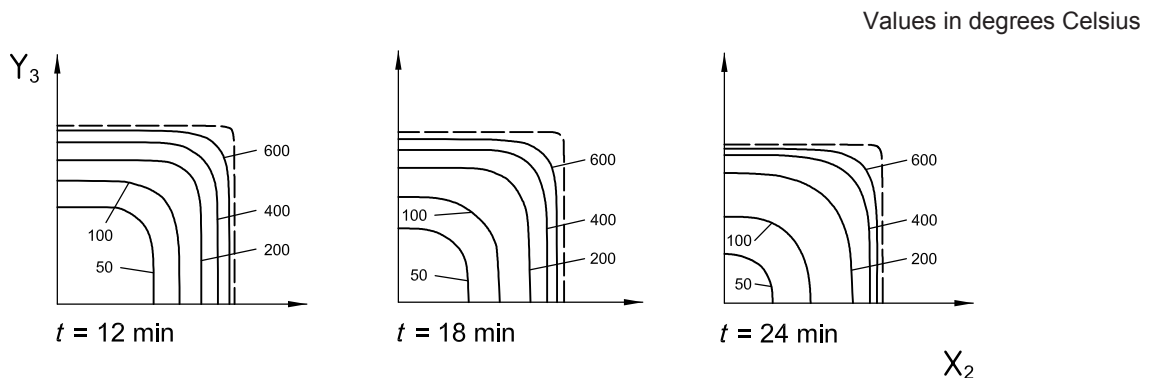

**Key**  
 $X_2$  distance  $x$  from the cross-section centre  
 $Y_3$  distance  $y$  from the cross-section centre  
 ----- outer surface of wood cross-section (located 50 mm from centre)

c) Temperature profile curves, expressed in degrees Celsius

Values in percent

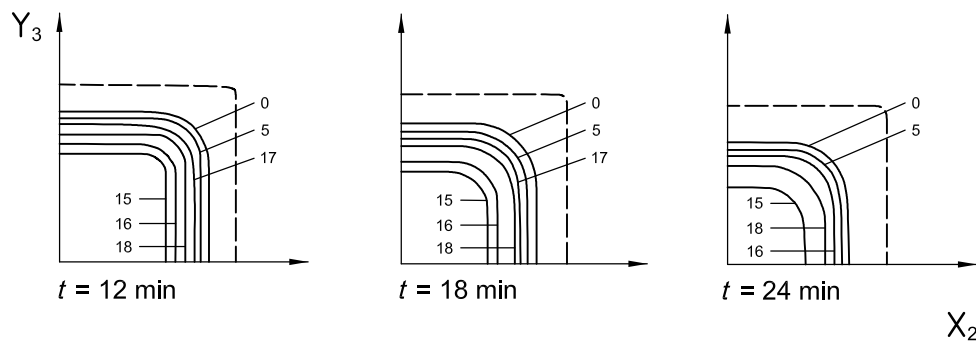

**Key**

$X_2$  distance  $x$  from the cross-section centre

$Y_3$  distance  $y$  from the cross-section centre

----- outer surface of wood cross-section (located 50 mm from centre)

**d) Moisture content curves, expressed in percent**

Values in kilopascals

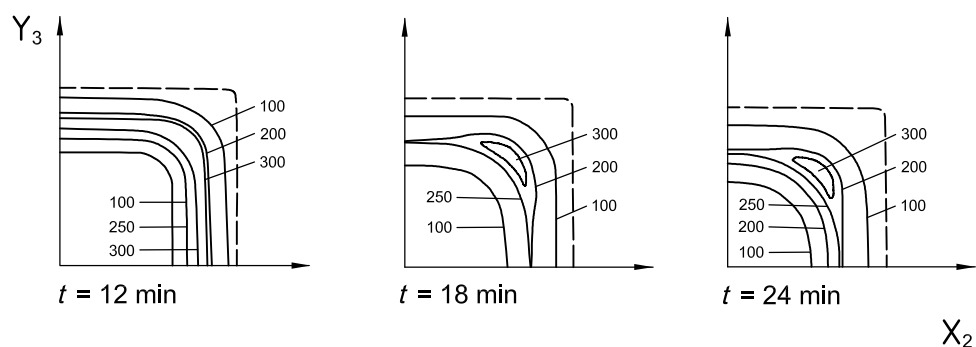

**Key**

$X_2$  distance  $x$  from the cross-section centre

$Y_3$  distance  $y$  from the cross-section centre

----- outer surface of wood cross-section (located 50 mm from centre)

**e) Pressure profile curves, expressed in kilopascals**

NOTE Data obtained for a quadrant (50 mm × 50 mm) taken from a cross-section, 100 mm × 100 mm, of a column of spruce with 14,5 % initial moisture ratio, thermally exposed on four sides.

**Figure 16 — Data obtained from a model and a related computer program are presented for the inter-related heat and mass transfer in fire-exposed timber structures**

A corresponding model for the inter-related heat and mass transfer in fire-exposed concrete structures, taking into account the desorption of physically adsorbed water, the thermal decomposition of water of crystallization, and the subsequent vapour transfer in the pores, is presented in reference [109]; see also reference [110]. The input material properties used in the model, as shown in Figure 17 [109], are the thermal conductivity of concrete  $\lambda$  as a function of temperature  $T$ , the permeability of concrete  $\kappa_D$  as a function of adsorbed and crystalline water content  $w + w_C$ , the equilibrium water content  $w_{eq}$  as a function of water vapour pressure  $p_v$ , the diffusion coefficient of vapour  $D_v$  as a function of temperature  $T$ , the diffusion coefficient of adsorbed water  $D_w$  as a function of temperature  $T$ , the crystalline water content  $w_{CT}$  as a function of temperature  $T$ , the void fraction  $\varepsilon$ , the density  $\rho$ , and product of the density and the specific heat capacity  $c_p$  of concrete as a function of adsorbed and crystalline water content  $w + w_C$ , and the heat of phase change of concrete  $L$  as function of temperature  $T$ .

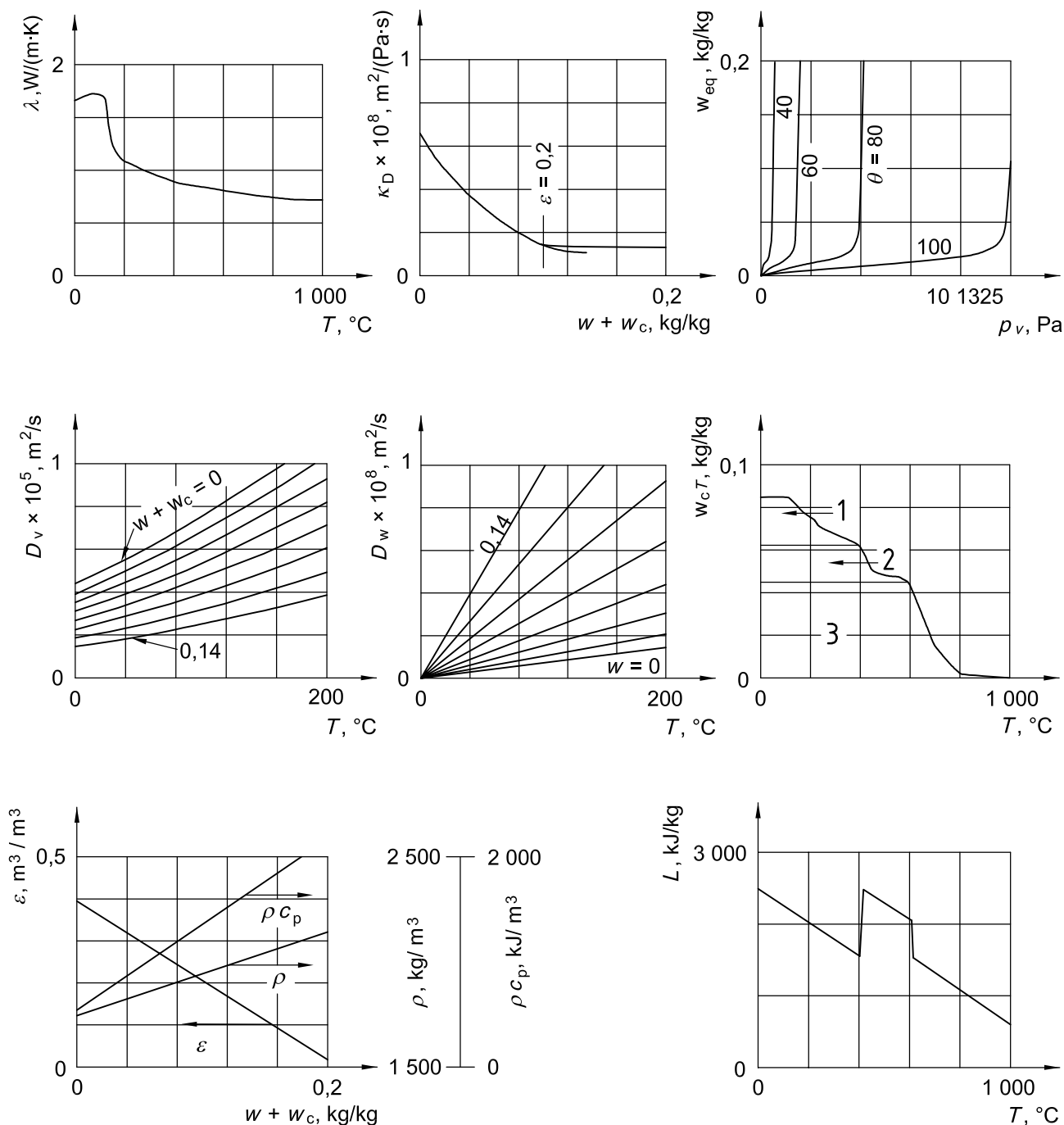

**Key**

- 1 gel water
- 2  $\text{Ca}(\text{OH})_2$
- 3 CSH phase

**Figure 17 — Input material properties used in the model, developed by Harada and Terai <sup>[109]</sup>, for the inter-related heat and mass transfer in a fire-exposed concrete wall**

For materials used for fire protection of steel structures, for instance, there are test methods developed to determine derived values characterizing the thermal material behaviour of a product subject to fire exposure in an integrated way. These values include indirectly the influence of initial moisture content, crack formations, disintegration of materials, and partial failure of the product and its fastening devices, if any. The derived values then are normally obtained from test results by the use of some simplified analytical simulation model. Consequently, such values do not represent any well-defined material or product properties, but are

influenced also by the characteristics of the analytical model, adopted for the evaluation. This leads to limitations with respect to a generalized application of the derived values.

For the practical determination of the transient temperature states of fire-exposed structures, numerical methods have been developed and arranged for computer calculations. The methods are based either on finite difference or finite element approximations. For the first group of methods, refer to references [28] and [45] and [111] to [114], and for the group using finite element methods, refer to references [28], [45] and [115] to [122].

The computer programs can be used directly in a rational structural fire engineering design or as a tool to calculate diagrams and tables, facilitating a practical determination of the design temperature state for varying fire exposure and structural characteristics. For a simulated real fire exposure according to Eurocode 1 [3] and Swedish Building Code [91], such a design basis is given in references [18], [19], [23], [30] and [32] for steel structures and in references [19], [23] and [44] for concrete structures. Formulae and diagrams for a direct determination of the charring depth in timber structures for the same fire exposure are presented in references [14] and [42].

The design basis available is exemplified by Figure 18 [44] which shows the decisive temperature distribution in the square cross-section, corresponding to the minimum load-bearing capacity, for an axially compressed concrete column, exposed on four sides to a specified simulated real fire exposure. For fire-exposed structures with such a high thermal inertia as reinforced concrete structures, the minimum load-bearing capacity is not reached until a significant time after the gas temperature in the fire compartment has passed its maximum value. This is clearly illustrated in Figure 18 by the isotherms for the fire load density  $q_t = 400 \text{ MJ}\cdot\text{m}^{-2}$ .

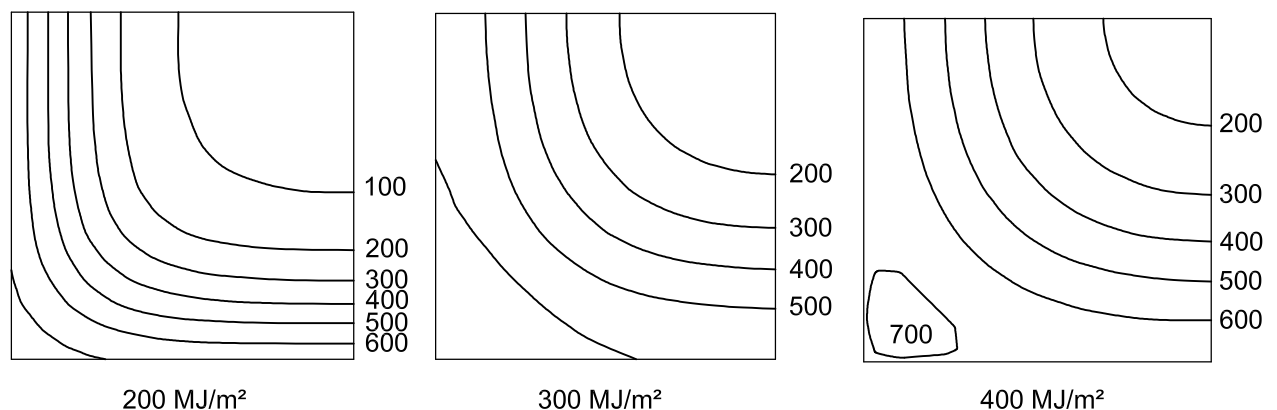

NOTE 1 The isotherms, shown for a quarter of the cross-section, correspond to the minimum load-bearing capacity of the column, when axially compressed, for three different values of the fire load density  $q_t$ .

NOTE 2 The opening factor of the fire compartment  $A\sqrt{h}/A_t = 0,04 \text{ m}^{1/2}$ .

NOTE 3 A column,  $300 \text{ mm}^2 \times 300 \text{ mm}^2$ , exposed on four sides to a simulated real fire exposure, according to Figure 13.

**Figure 18 — Calculated temperature distribution in a cross-section of a concrete column**

### 5.3 Mechanical material properties and structural behaviour

A reliable calculation of the mechanical behaviour of a fire-exposed structure on the basis of the transient temperature state requires access to validated models for the mechanical behaviour of the materials involved within the temperature range associated with fires [123].

In computer programs for a structural fire analysis, it is not unusual to find that the material model for the mechanical behaviour is specified by temperature-dependent stress-strain curves that either neglect or indirectly include the creep strains and transient strains. Figure 19 exemplifies such a model for normal

concrete with siliceous aggregates, which indirectly includes these strains [4], [6], [124]. The stress-strain curves, then, are determined either from small-scale material tests or from full-scale tests on that type of load-bearing structure, for which the computational procedure is developed.

Such a technique may be acceptable as an intermediate solution. From a long-term perspective, however, it is important that the material behaviour models be formulated so that they are independent of the type of load-bearing structure and are based on input information received from functionally well-defined material tests.

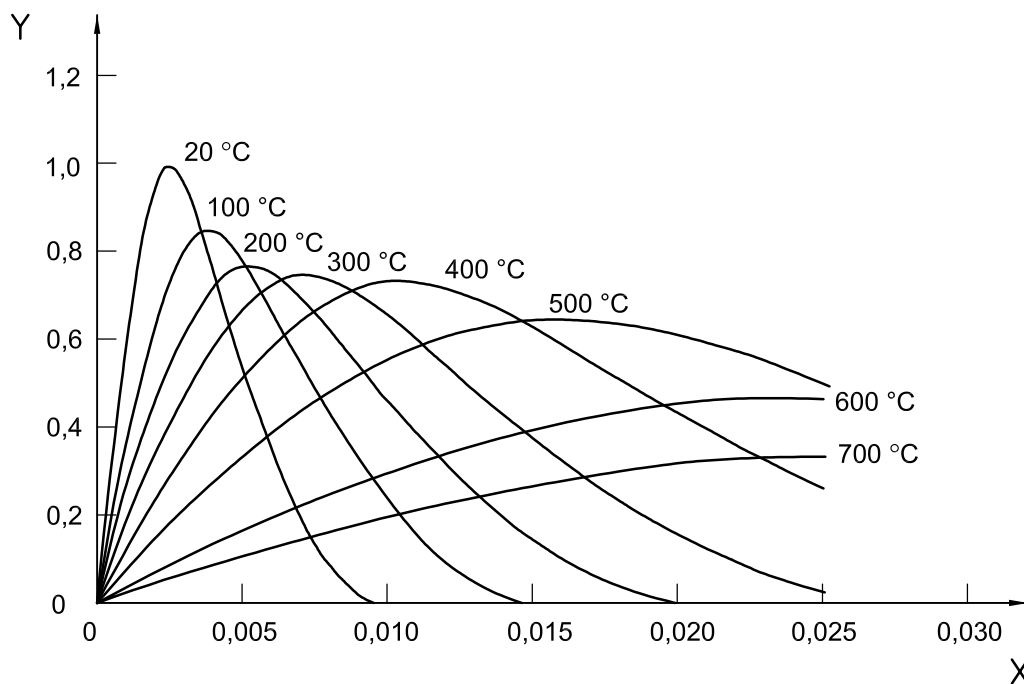

**Key**

- X strain,  $\epsilon$
  - Y relative stress,  $\sigma/f_c'$
  - $f_c'$  compressive strength at 20 °C
- Curves indicate values for temperature.

**Figure 19 — Stress-strain curves at elevated temperatures for concrete with siliceous aggregates**

Fundamental parameters in available tests for determining the mechanical material properties at elevated temperatures are the heating process, application and control of load, and control of strain. Practically, the tests can be referred to different testing regimes as follows (Figure 20) [123], [125]:

- a) steady state tests, giving information on
  - stress-strain relationship (stress rate control,  $\dot{\sigma} = \text{const}$ ),
  - stress-strain relationship (strain rate control,  $\dot{\epsilon} = \text{const}$ ),
  - creep (stress control,  $\sigma = \text{const}$ ),
  - relaxation (strain control,  $\epsilon = \text{const}$ ),
- b) transient state tests, giving information on
  - failure temperature, total deformation (stress control,  $\sigma = \text{const}$ ),
  - restraint forces, total forces (strain control,  $\epsilon = \text{const}$ ).

As the material properties measured depend on the test method used, it is necessary that test results always be accompanied by an accurate specification of the test conditions applied.

For steel, there is an analytical modelling technique available that enables a transfer of results from steady state tests to transient state tests, and vice versa<sup>[126]</sup>.

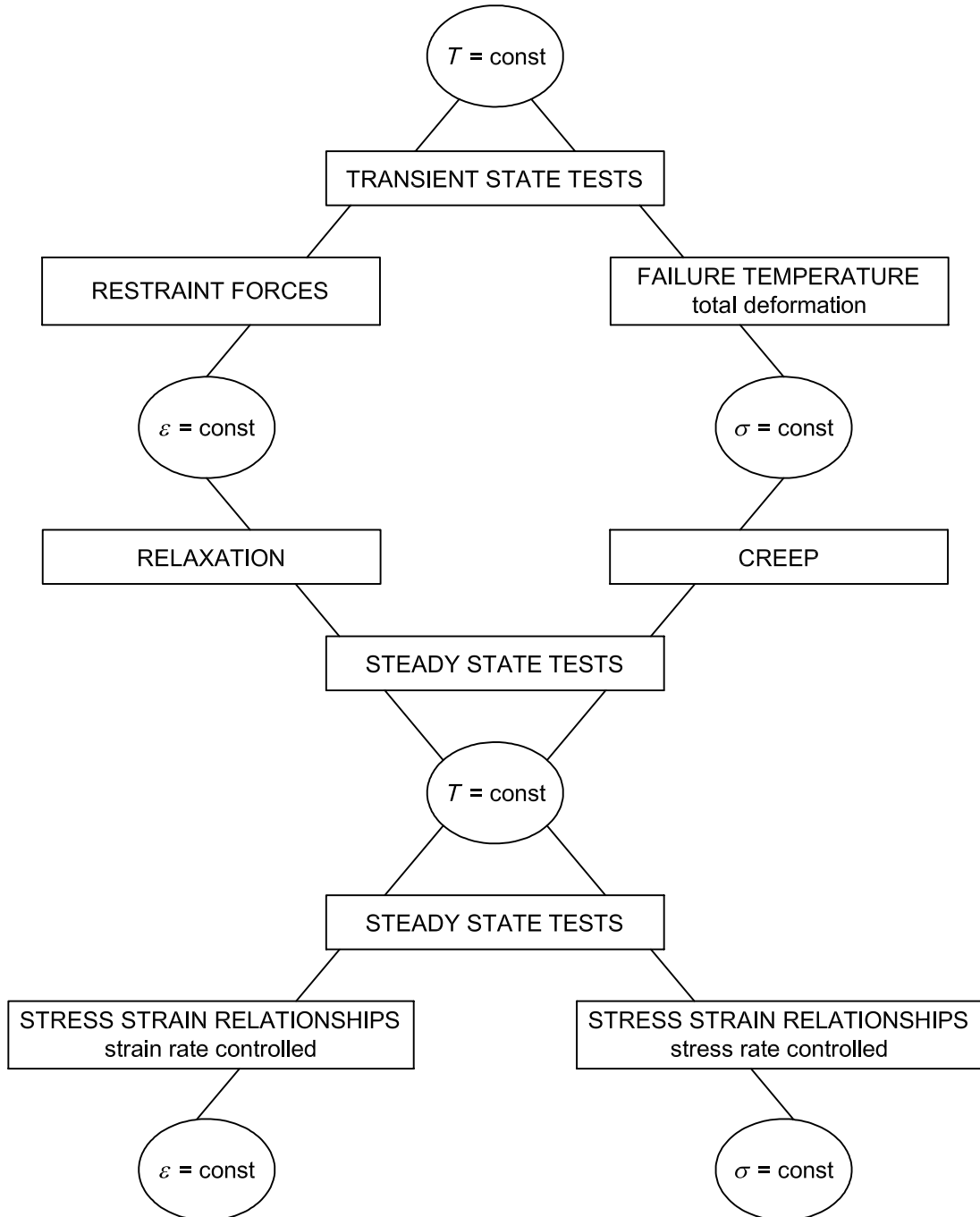

**Figure 20 — Different testing regimes for determining mechanical properties of materials at elevated temperatures**

As already stressed, a calculation of the mechanical behaviour and load-bearing capacity of a fire-exposed structure on the basis of the transient temperature state requires access to validated models for the mechanical behaviour of the structural materials involved within the relevant temperature range.

For **steel**, such models have been available for many years [125] to [133]. In these models, the total strain is divided into thermal strain, instantaneous stress-related strain, and creep strain. Some of the models operate with temperature-compensated time according to Dorn [127].

Analytical models to determine the mechanical behaviour and load-bearing capacity of fire-exposed steel beams, columns and frames are presented in references [28], [70], [128] to [144], see also reference [45], in which further references are given. The most generally applicable models are those described in references [130] to [133] and [135] to [143], and examples of their ability to deal with multi-story and high rise building frames are included in references [132], [133] and [140] to [143]. The computer program, put forward in reference [142], integrates the fire exposure simulation, comprising field modelling of open and enclosed pool and jet fires, the heat transfer simulation, and the simulation of the mechanical response of complex offshore structures. Simplified design bases, giving directly the load-bearing capacity for a design temperature state or the critical temperature state for a design load effect, are presented in references [18], [22], [23], [25], [27], [30], [32], [34], [36], [38] and [128].

Figure 21<sup>[140]</sup> demonstrates a structural fire analysis of a hyperstatic load-bearing structure by using a substructure technique—dividing the total structure into the fire-exposed local substructure, the adjacent substructure, and the surrounding substructure. Thermal stresses and deflections are important for the local and adjacent substructures, but practically negligible for the surrounding substructure. The fire-exposed local structure must be analysed by an elasto-plastic-creep theory, while the adjacent and surrounding substructures normally behave in the elastic range.



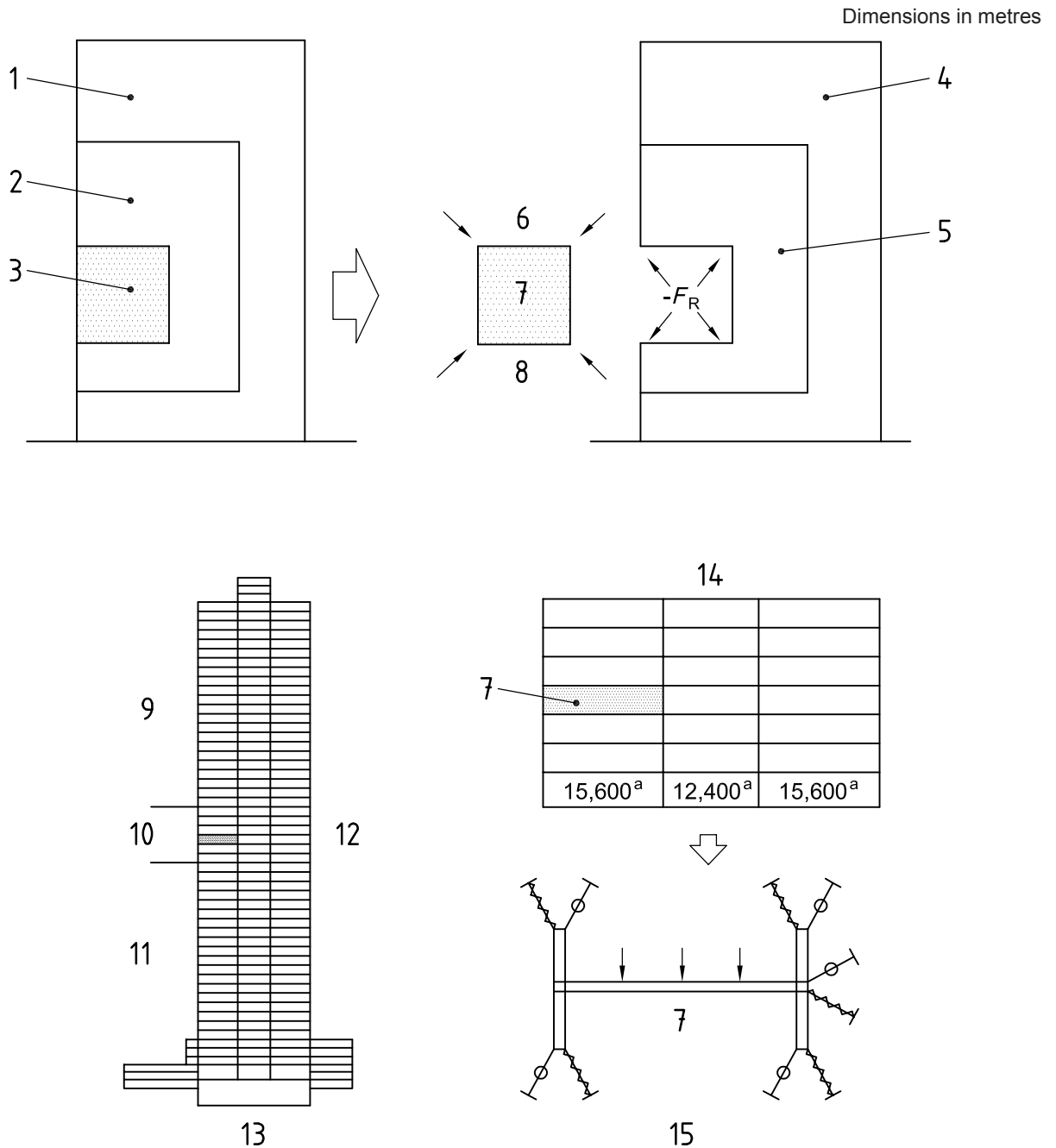

**Key**

- 1 surrounding substructure
  - 2 adjacent substructure
  - 3 local substructure
  - 4 condensed surrounding substructure
  - 5 condensed adjacent substructure
  - 6 end restraint force  $F_R$
  - 7 fire
  - 8 divided local substructure
  - 9 surrounding substructure (upper)
  - 10 adjacent substructure
  - 11 surrounding substructure (lower)
  - 12 30th floor
  - 13 whole structure
  - 14 adjacent substructure
  - 15 local substructure
- <sup>a</sup> Span of the floor beams between columns.

**Figure 21 — Division of a high-rise building frame into local substructure, adjacent substructure, and surrounding substructure for rationalization of the structural fire analysis**

A sole illustration of the capabilities of available methods for a structural fire analysis is given in Figure 22<sup>[14]</sup>. Figure 22 relates to a steel frame, under combined dead and live load conditions, in seven stories and three bays. It shows the deformation history for a part of the frame, including the fourth and fifth floors of an end-bay, at a specified simulated real compartment fire on the fourth floor. The deflections and expansions of the frame members were calculated by using a nonlinear finite element method, simulating the elasto-plastic-creep thermal behaviour. The upper deformation history in Figure 22 applies to the heating period and the lower deformation history to the subsequent cooling-down period of the fire exposure.

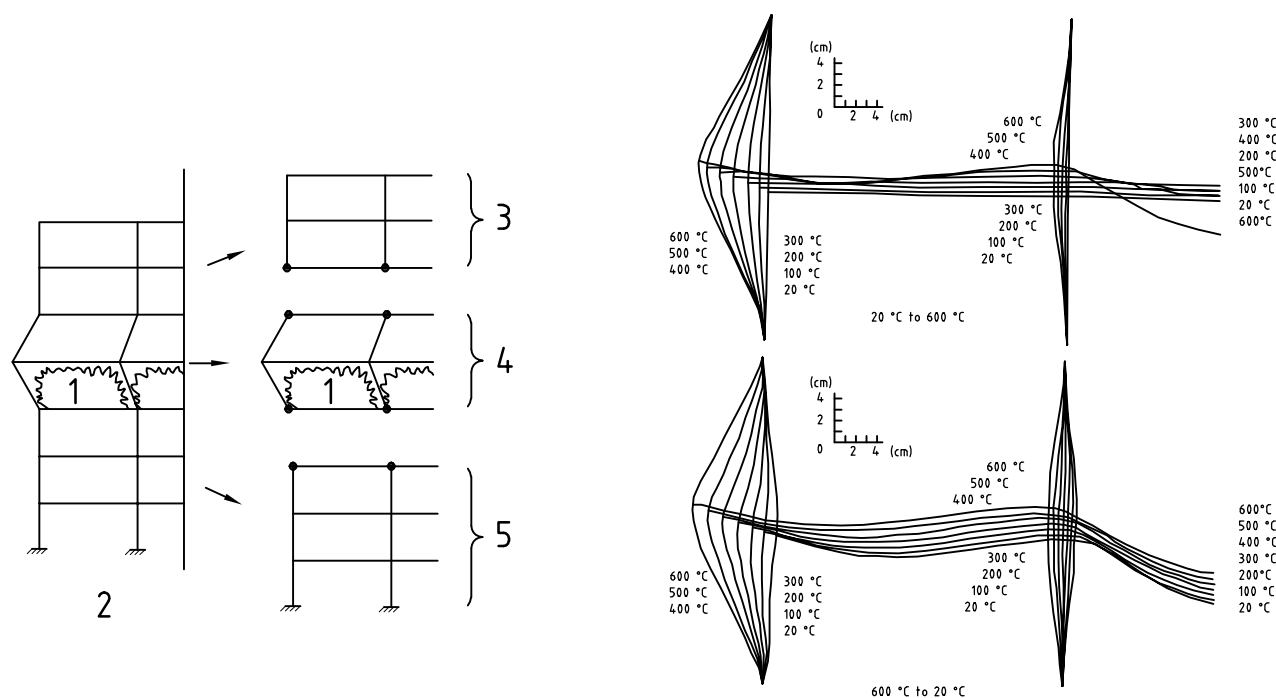

#### Key

- 1 fire
- 2 3-bay frame
- 3 linear response part
- 4 nonlinear response part
- 5 linear response part

**Figure 22 — Deformation history for a part of a multi-story steel frame, exposed on the fourth floor to a simulated, simplified real compartment fire**

For **concrete**, the mechanical behaviour at elevated temperatures is more complex than for steel. For stressed concrete under transient conditions, considerable deformations develop during the first heating that do not occur at steady state temperature conditions.

For practical design, the total strain for fire-exposed concrete, stressed in compression, can be assumed to follow the formula<sup>[11]</sup>:

$$\varepsilon = \varepsilon_{th}(T) + \varepsilon_{\sigma}(\tilde{\sigma}, \sigma, T) + \varepsilon_{cr}(\sigma, T, t) + \varepsilon_{tr}(\sigma, T) \quad (29)$$

where

$\varepsilon_{th}$  is the thermal strain, including shrinkage, measured on unstressed specimens under variable temperature;

$\varepsilon_{\sigma}$  is the instantaneous, stress-related strain, based on stress-strain relations, obtained at a rapid rate of loading under constant, stabilized temperature;

- $\varepsilon_{cr}$  is the creep strain or time dependent strain, measured under constant stress at constant, stabilized temperature;
- $\varepsilon_{tr}$  is the transient strain accounting for the effect of temperature increase under stress, derived from tests under constant stress and variable temperature;
- $\sigma, \bar{\sigma}$  are the stress and stress history, respectively;
- $T$  is the temperature;
- $t$  is the time.

Parameter formulations for each of the strain components are given in reference [11], as well as practical guidance on the application of the material behaviour model at a transient stress and temperature state. Alternative model formulations of the mechanical behaviour of concrete at transient elevated temperatures are derived in references [12], [13] and [145]. Normally, the transient strain  $\varepsilon_{tr}$  is the predominant component; see Figure 23<sup>[11]</sup>.

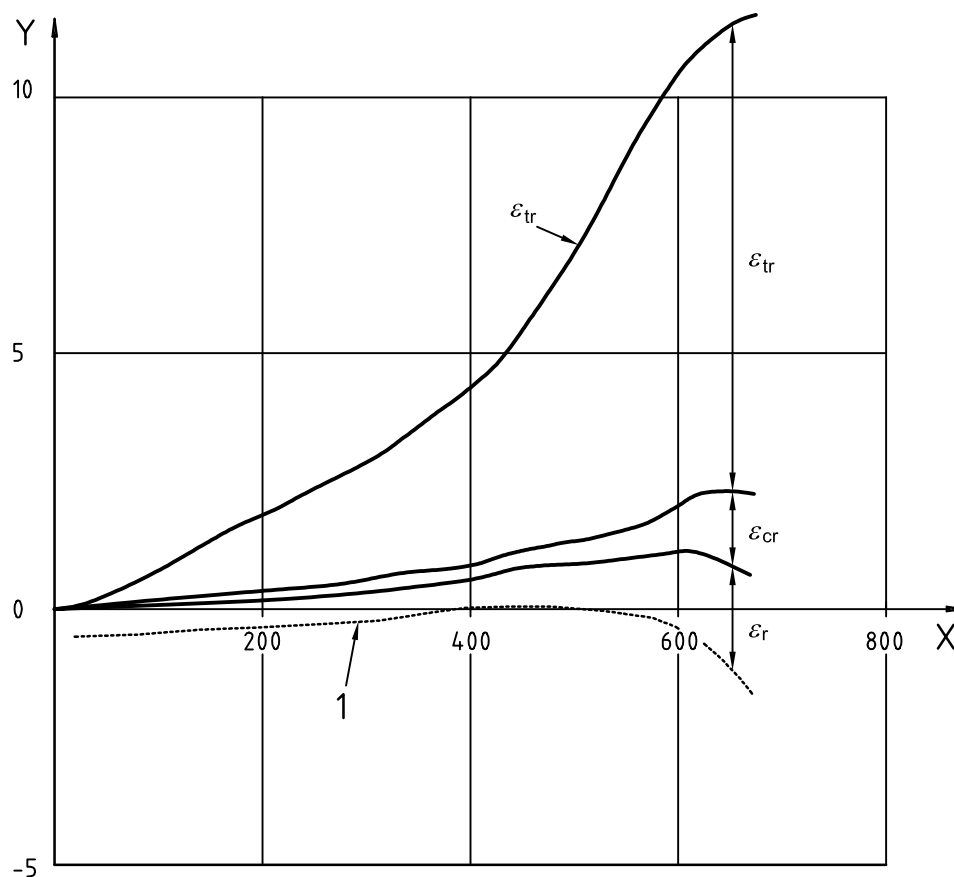

**Key**

- X temperature, °C
- Y strain, %
- 1 measured total deformation

Rate of heating 5 °C·min<sup>-1</sup>

**Figure 23 — Total deformation and relation between different strain components for a heat-exposed concrete specimen, axially loaded in compression to a stress level equal to 35 % of the ambient temperature strength**

A multi-axial constitutive model for concrete in the temperature range up to 800 °C is formulated in reference [146]. The deformation behaviour is isotropic, elastic-viscoplastic-plastic in the compression region and brittle failure is assumed in the tensile region. A comprehensive experimental study is reported in reference [147].

A comprehensive survey on the mechanical properties of concrete under high temperature exposure is given in reference [148].

Access to structure independent, functionally well-defined material behaviour models of the kind exemplified is a condition for prediction by simulation models and related computer programs for the mechanical behaviour and load-bearing capacity of fire-exposed reinforced concrete structures and composite steel-concrete structures. Models and computer programs, more or less accurately fulfilling this condition, are presented in references [28], [35], [113], [124], [138], [143] and [149] to [155], dealing with beams, columns and frames. Models and computer programs for evaluating the fire response of reinforced concrete slabs are published in references [156] and [157]. Simplified methods, facilitating the practical determination of primarily the load-bearing capacity, can be found in references [4], [6], [20] to [24], [26], [31], [41], [43], [44], [111], [112], [139], [158] and [159].

A sole illustration of the capabilities of the computer programs, fulfilling the requirements of functionally well-defined, validated material behaviour models, is shown in Figure 24<sup>[160]</sup>. It presents the time curves of the axial restraint force, calculated by the use of the computer program CONFIRE<sup>[35]</sup>, for a simply supported concrete slab at different permissible axial expansions  $\Delta L = 0$  mm, 2 mm, 4 mm and 6 mm, followed by a complete restraint against further expansion. The slab is thermally exposed from below according to the standard fire resistance test. The second-order effects are included in the full-line curves, but neglected in the dash-line curves. The great difference between the two sets of curves emphasizes the necessity of including these effects in analysing a structural fire behaviour of this kind.

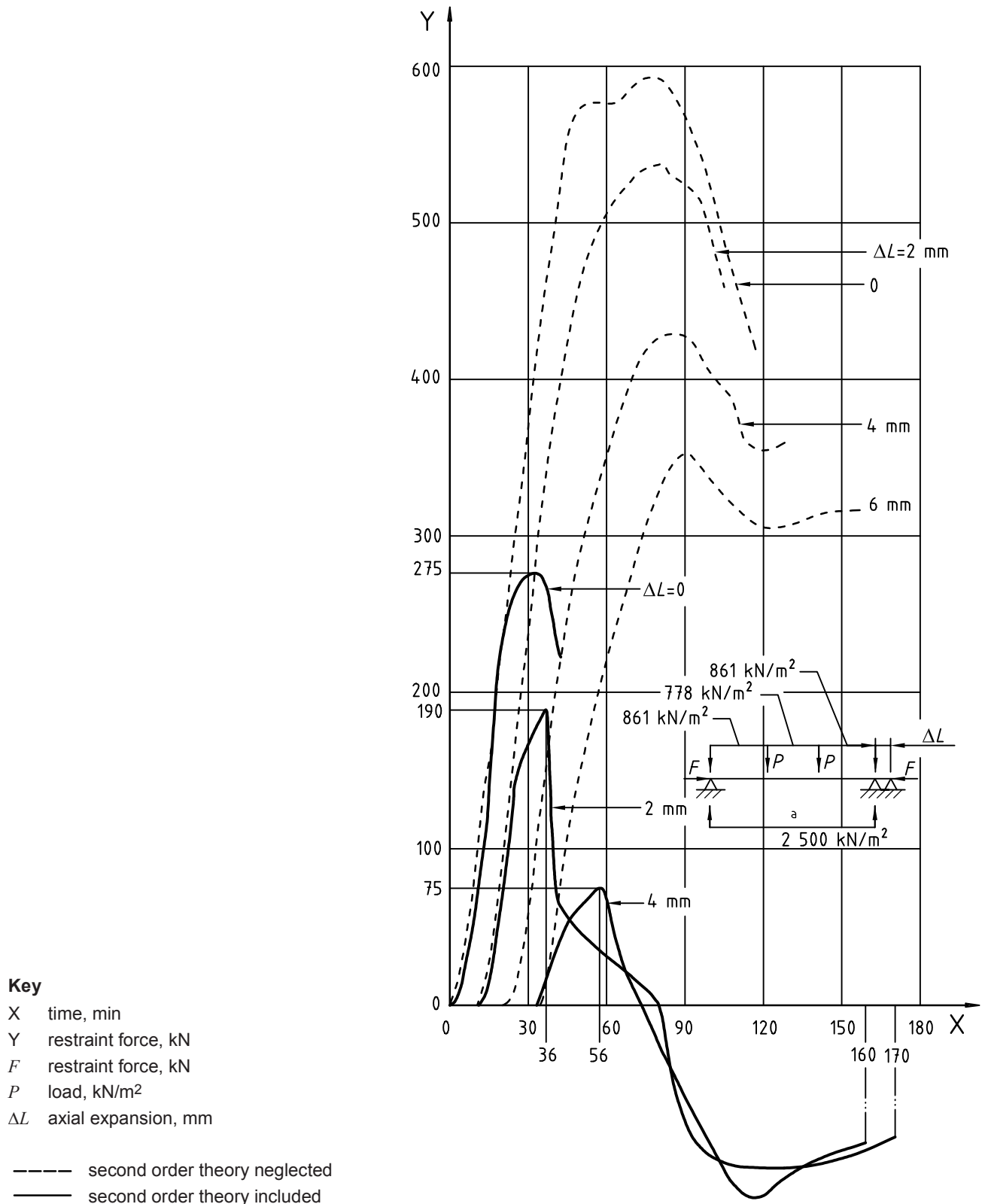

<sup>a</sup> ISO 834 fire resistance test furnace heating conditions.

NOTE Thermal exposure is from below according to the standard fire resistance test.

**Figure 24 — Calculated restraint force  $F$  for a simply supported, concrete plate strip at different permissible, axial expansion  $\Delta L$ , followed by a complete restraint**

The methods referred to, simplified as well as the more accurate, for determining the mechanical behaviour and load-bearing capacity of fire-exposed concrete structures do not include failures with respect to shear, bond and anchorage, and spalling.

The risk of spalling occurring can be roughly estimated by design diagrams, based on comprehensive experimental studies [161] or on theoretically derived failure criteria. Input data would include the compressive stresses from the temperature gradient and the external loading, the tensile stress due to the vaporization and migration of moisture, and the tensile concrete strength [162]. There are also early theoretical approaches for a principal description of the physical processes causing the spalling [163], [164], [165]. A recent world-wide review of the current level of knowledge regarding spalling of high strength concrete at elevated temperatures is reported in reference [166].

Figure 25, from an early Russian contribution by Zhukov [162], illustrates the stress distribution around a propagating crack, initiating an explosive spalling of a fire-exposed concrete wall. The state of stress is composed of the compressive stress from the temperature gradient  $\sigma_c^c$ , the compressive stress from the external loading  $\sigma_c^n$ , and the tensile stress due to vaporization and migration of moisture  $\sigma_r$ . The following failure criterion is formulated

$$\sigma_r^2 \left[ 1 + \frac{\nu}{\sigma_r} (\sigma_c^c + \sigma_c^n) \right] \geq f_r^2 \quad (30)$$

where

$f_r$  is the tensile strength of concrete in the surface of failure;

$\nu$  is Poisson's ratio.

For  $\sigma_r$ , the following formula then is given:

$$\sigma_r = \frac{32\pi\eta\Delta T}{L\rho_n} - \frac{N\lambda w_0}{(1-\pi_s)\pi_s} \quad (31)$$

where

$\eta$  is the dynamic vapour viscosity;

$\Delta T$  is the temperature difference between the heated surface and the failure surface;

$N$  is the quantity of pores in which vapour transfer occurs;

$\lambda$  is the thermal conductivity of concrete;

$w_0$  is the initial moisture content;

$L$  is the latent heat of evaporation of water;

$\rho_n$  is the vapour density;

$\pi_s$  is the total porosity.

The important progress during the last years in modelling the heat and mass transfer in fire-exposed structures [15], [108] to [110] has considerably increased the possibilities of developing a more complete and accurate theory of spalling and an improved related design basis. An experimental program, described summarily in reference [167], illustrates the difficulties in deriving a deterministic model for explosive spalling, however, and highlights the need to consider spalling in a stochastic manner.

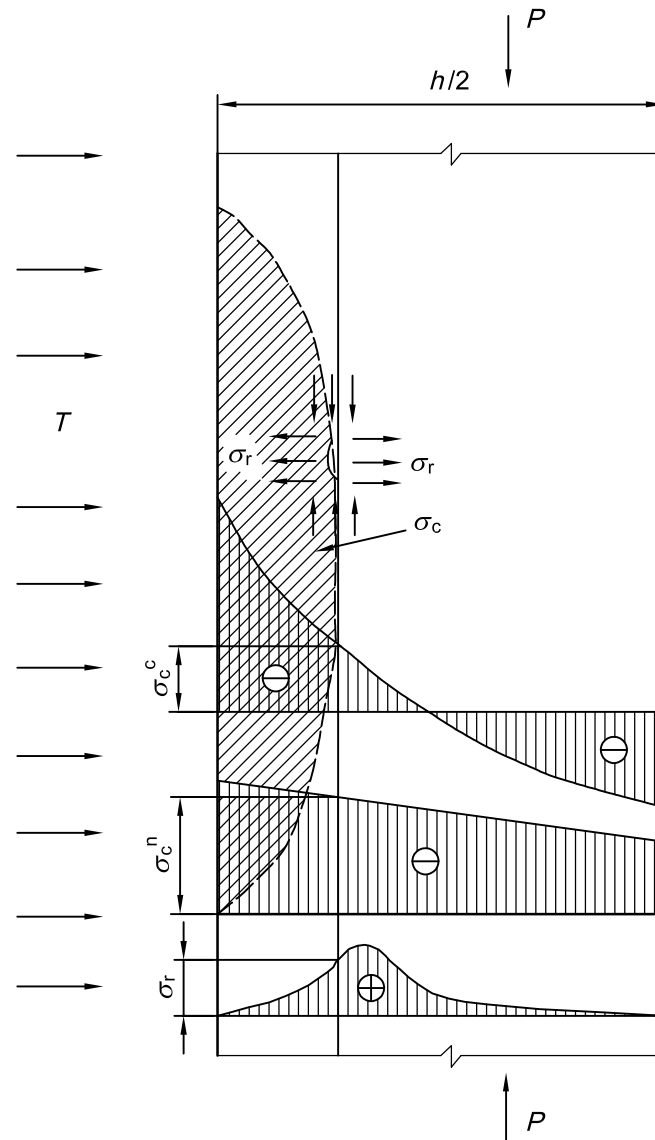

**Key**

- $T$  temperature
- $P$  applied force
- $\sigma_c^c$  compressive stress from the temperature gradient
- $\sigma_c^n$  compressive stress from the external loading
- $\sigma_r$  tensile stress due to vaporization and migration of moisture

**Figure 25 — Stress distribution around a propagating crack, initiating explosive spalling of a fire-exposed concrete wall**

For shear, bond and anchorage, there are no validated calculation methods available for a structural fire design (see reference [168]) presenting the state of the art and the need of further research. In a practical design, it is therefore necessary to detail the structure in such a way that these types of failure will have a lower probability of occurrence than the failures being dealt with properly in the design<sup>[169]</sup>. A first method of design of steel and concrete composite beams with regard to the fire behaviour of shear connectors is reported in reference [170], based on a comprehensive theoretical and experimental research program.

For fire-exposed load-bearing **timber** structures, the potential for an analytical modelling of the mechanical behaviour and load-bearing capacity is more limited than for steel and concrete structures. Available information on the strength and deformation properties is mainly based on results of tests with small specimens, conditioned to different combinations of temperature and moisture content [39], [171]. Examples of

the few studies performed on “full-size” specimens are presented in references [172] and [173]. Furthermore, there are a few studies presented on the mechanical behaviour of wood subject to fire exposure with a more general approach [174],[175]. However, at present, there is no analytical model developed for the mechanical behaviour of wood describing the deformation process at simultaneous transient states of stress, temperature and moisture. This limits the structural fire design normally to a determination of the ultimate load-bearing capacity on the basis of simplified reduction factors[7], [23], [39], [42], [47], [59]. A design method with respect to lateral buckling of fire-exposed laminated wood beams is presented in reference [176].

## 6 Need for further development of calculation models and related computer programs for structural fire design: Examples

In the preceding clauses, a general survey has been given of the state of the art regarding the different internationally applied methods for a structural fire engineering design, of the characteristics of a reliability-based approach to such a design and its inherent component uncertainties, and of the related deterministic models for the fire exposure and the thermal and mechanical behaviour of the structures subject to fire.

In this clause, some conclusions from this survey are drawn regarding the need for further development of calculation models and related computer programs for a theoretical structural fire design. The need is illustrated below by examples of fire research fields needing further work. Some examples refer to the complete process of structural fire design, while others refer to individual components of the design process. The examples do not pretend to cover completely the need for further developing calculation models and related computer programs.

Of the fire research subjects compiled, the two on safety principles and levels of requirement and on reliability-based structural fire design have the highest priority. Within 6.1, 6.2.1, and 6.2.2, respectively, subjects are listed in order of priority.

### 6.1 Complete process of structural fire design

Examples for further development of the complete process of structural fire design include the following.

- a) *Safety principles and levels of requirement*: to define requirements for fire-exposed load-bearing and separating structures that are relevant to total fire risk scenario in buildings and to derive principles to verify structural fire behaviour according to the modern safety approach used in qualified static design.

The principles shall be the following:

- 1) neutral with respect to structural material;
  - 2) neutral with respect to method of verification (tests versus calculation, standard and other nominal fire exposure versus simulated natural fire exposure);
  - 3) formulated so that inherent uncertainties of input data and method of verification can be considered;
  - 4) reasonably calibrated against existing practice.
- b) *Reliability-based structural fire design*: to derive required values of the safety index, when using a FORM approximation, and of the partial safety factors and the safety and frequency differentiation factors, when applying the practical design format. In the present version of the Structural Fire Eurocodes, all partial safety factors are put equal to unity, which is not satisfactory. An example of a temporary improvement is given in the Swedish National Application Documents for the Eurocodes<sup>[177]</sup>. In these documents, the partial safety factor in the fire design for the mechanical material properties  $\gamma_{M, fi}$  is differentiated with respect to the type of structural material according to the formula

$$\gamma_{M, fi} = \alpha \times \gamma_M \quad (32)$$



where

$$\chi = 0,8$$

$\gamma_M$  is the value of the partial safety factor for the respective structural material in normal design.

- c) The task includes sensitivity and uncertainty studies of the complete design process as well as of its components.
- d) To draft standard guides and develop means for evaluating the predictive capability of calculation models dealing with the fire exposure and the thermal and mechanical behaviour of load-bearing and separating structures subject to fire, and for documenting related computer software.
- e) To develop computer programs for the complete fire design process, integrating fire exposure simulation, heat transfer simulation, and simulation of the mechanical response for different types of structural applications<sup>[142]</sup>.

## 6.2 Main components of structural fire design

### 6.2.1 Fire exposure

Examples for further development of the main components of structural fire design with respect to fire exposure include the following.

- a) To improve the information available and to build up an international data base on the rate of heat release of different fire load components in compartment fires.
- b) To critically review the design fires available and evaluate their applicability and limitations for structural fire design.
- c) To improve the knowledge on flames and hot gases emerging from the openings of the compartment and the related fire exposure on external load-bearing structures.
- d) To develop a simplified design basis for local fires.
- e) To further develop CFD-modelling of the fire process and the related exposure on the load-bearing and separating structures with special priority to large compartments and compartments of complicated geometry, including decisive preflashover fire exposure.
- f) To improve the understanding of the influence of fire-generated pressures on the ability of a separating element to contain a fire (maintain integrity), which, in turn, will allow the heat flow through permeable elements to be modelled, e.g. roller shutters, lift doors and dry wall construction.
- g) To improve the design basis with respect to the role of glazings for the development of preflashover and postflashover compartment fires and related fire exposure on the structures.
- h) To improve the information and design basis with respect to different types of integrated or subsequent exposures, for instance:
  - 1) interaction of fire development and fire extinguishment<sup>[178]</sup>, and interaction of fire development and structural failure, which are combinations occurring simultaneously, and
  - 2) combination of explosion and fire exposure<sup>[179]</sup>, and combination of earthquake and fire exposure<sup>[180]</sup>, which are events occurring in sequence.

### 6.2.2 Thermal and mechanical behaviour

Examples for further development of the main components of structural fire design with respect to thermal and mechanical behaviour include the following.

- a) To further develop calculation models for the inter-related heat and mass transfer under fire exposure, including the pyrolysis and charring of combustible structural materials; to make the connected computer programs more user-friendly; to improve the information available; and to build an international database on the input material properties required.
- b) To improve the theory and criteria of spalling of concrete and other cementitious materials subject to fire exposure.
- c) To develop calculation models for predicting the residual state after fire and the post-fire structural behaviour<sup>[141],[151],[181] to [184]</sup>.
- d) To improve the calculation models for instability failure and connected second-order phenomena for fire-exposed slender and/or thin-walled structures with respect to torsional buckling, torsional-lateral buckling, local buckling, and overall, integrated buckling.
- e) To improve the material models for the mechanical behaviour at elevated transient temperatures, formulated so that they are independent of a type of load-bearing structure and based on input information received from functionally well-defined material tests. The present state of knowledge is unsatisfactory regarding validated models for aluminium and concrete, especially for multi-axial stress-strain conditions. There is no calculation model available for the mechanical behaviour of wood under fire exposure, describing the deformation process at simultaneous transient states of stress, temperature and moisture.
- f) To develop more practically adapted fire design methods for large and/or complex, two- and three-dimensional frames, having internal and/or external restraints to axial elongation and/or rotation of individual members due to heating.

Further research work is required to develop calculation models and related computer programs to assess the following conditions:

- fire behaviour of structural members under transversally and longitudinally non-uniform heating;
- failure of fire-exposed concrete and composite structures with respect to shear, bond and anchorage<sup>[168]</sup>;
- fire behaviour of joints and connections for different types of fire-exposed structures and structural members<sup>[185] to [187]</sup>.

## 7 Need for fire tests to determine input material data for structural fire design

In presenting the state of the art of internationally applied methods for a structural fire engineering design and related models for fire exposure, and thermal and mechanical behaviour of structures subject to fire, the importance of having access to input material data has been stressed. These data, required for the design, are received from functionally well-defined material tests. As the material properties that are measured frequently depend on the test method used, it is necessary that the test results always be accompanied by an accurate specification of the test conditions applied.

In this clause, the material properties, required as input data for a computational structural fire design, are identified and commented on with respect to available test methods for their determination. Conclusions are drawn regarding the need for internationally standardized fire tests to obtain these input material data, focusing on thermal and mechanical material properties. When evaluating the quality of relevant tests and prescribing the accuracy required of the test results, it is important to have the uncertainties of the design process, illustrated in Clause 5, as background.

### 7.1 Properties related to fire load density and fire exposure

The definition of fire load density introduces these properties:

- a) net calorific value of the combustible materials  $H$ , and

b) degree of combustion of the combustible components of the fire load  $\mu$ .

The solving of the energy and mass balance equations of the compartment fire requires information on these properties:

- net calorific value of the combustible materials  $H$ ;
- combustion enthalpy, developed per unit mass of air, for the combustible materials  $H/r$ ;
- rate of heat release, RHR, versus radiation or heat flux exposure level, for the combustible items in a fire compartment (the term  $\dot{h}_c$ );
- specific heat capacity of the combustion gases  $c_p$  (the term  $\dot{h}_e$ );
- emissivity of flames and combustion gases (the term  $\dot{h}_r$ );
- thermal properties of the structures bounding the fire compartment (the term  $\dot{h}_w$ ), as dealt with in 7.2;
- the fraction of enthalpy release outside the fire compartment.

Means available to determine the properties listed above are bench-scale reaction to fire tests, such as the ISO cone calorimeter, ignitability and surface spread of flame tests; simplified full scale tests, such as the ISO room/corner fire test for combustible linings and the corresponding test for furniture; and analytical and numerical models for transferring data from bench-scale tests to the full-scale compartment fire<sup>[188] to [191]</sup>. The net calorific value  $H$  can be determined by the bomb calorimeter test, according to DIN 18230 at specific combustion conditions.

## 7.2 Thermal material properties

The solving of the equations of transient heat flow to and within a fire-exposed structure, Equations (26) to (28), requires information on these properties:

- a) emissivity  $\varepsilon$  of the fire-exposed surfaces of the structure;
- b) thermal conductivity  $k$  of the structural materials;
- c) specific heat  $c_p$  of the structural materials;
- d) latent volumetric heat due to phase changes at various temperature levels  $l_i$  of the structural materials;
- e) rate of internally generated heat per volume  $Q$  in the structure.

For structures of combustible material, additional information on the rate of charring is required.

It is necessary that the properties be known as a function of temperature for the heating, as well as the subsequent cooling-down phase, of the compartment fire.

Examples of available tests to determine thermal conductivity, specific heat and thermal diffusivity are the variable state curve-fitting method, the heat pulse methods, the periodic temperature method, the radiation method, the constant rate of temperature rise method, the furnace method, the transient plane source method, and the differential scanning calorimetry<sup>[191] to [193]</sup>. For determining the rate of charring, refer to the methods presented in references [14] to [16].

The different tests mentioned to determine thermal conductivity, specific heat and thermal diffusivity have been compared in the projects described in references [192] and [193]. As a result of this study, the transient plane source method (TPS), combined with an electrical furnace for heating the samples to prescribed

temperatures, is recommended for further development towards automatization and future adoption as a standard test. The method has the advantage of producing information on thermal conductivity and thermal diffusivity, and hence also on specific heat, in one single measurement.

A more advanced approach, consisting of a solution of the inter-related heat and mass transfer equations, as illustrated in references [15], [108] to [110], requires access to information on a considerable number of additional properties:

- permeability of the structural materials;
- diffusion coefficient of adsorbed water and vapour in the structure;
- void fraction of the structure;
- equilibrium water content in the structure;
- crystalline water content in the structure;
- reaction rate and heat of reaction in the process of pyrolysis for structures of combustible materials;
- heat of reaction of oxidation at the surface of structures of combustible material; and
- specific heat and dynamic viscosity of water vapour and volatile pyrolysis products.

As concerns the more immediate need for internationally standardized tests for getting the thermal material input data required for structural fire design, it is reasonable to limit the development of such tests to the properties of thermal conductivity, specific heat, thermal diffusivity, and rate of charring for combustible structural materials. The next step would be to include tests to determine additional material input data necessary for a more advanced structural fire design. These data would be based on the inter-related heat and mass transfer equations and would require very extensive pre-standardization work. It should be noted that many of these properties may depend upon other effects, such as mechanical degradation, e.g. cracking, spalling, etc. Therefore, the development and standardization of suitable methods should aim at measuring the effective (gross) values under fire conditions.

### 7.3 Mechanical material properties

A transfer of the transient temperate and moisture states for fire-exposed structures and structural members to the ultimate load-bearing capacity of a structure requires information on one or several of the following mechanical material properties:

- a) compressive strength;
- b) tensile strength;
- c) shear strength, including strength of shear connectors;
- d) torsional strength;
- e) for reinforced structures, strength with respect to bond and anchorage, as a function of temperature and, when relevant, stress history.

For a determination of the deformation behaviour and the ultimate load with respect to instability failure of fire-exposed structures and structural members, additional information is required for these properties:

- modulus of elasticity;
- stress-strain relationship;

- steady state and transient creep;
- steady state and transient shrinkage;
- thermal expansion;
- relaxation,

as a function of temperature, and, when relevant, time and stress history. See Equation (29).

As described in 6.3, the fundamental parameters in available test methods for determining mechanical material properties at elevated temperatures are: the heating process, the application and control of the load, and the control of the strain. Depending on how these parameters are specified, different testing regimes are defined according to Figure 20<sup>[123]</sup>, <sup>[125]</sup>. As the material properties measured depend on the test method used, it is necessary, as has already been stressed, that the test results always be accompanied by an accurate specification of the test conditions applied.

In the RILEM reports<sup>[125]</sup>, <sup>[148]</sup>, comprehensive surveys are presented on mechanical properties of steel and concrete under high temperature exposure (see also reference [44]). These surveys cover practically all mechanical material properties, listed above. There is a strong need for a similar survey on the mechanical properties of wood. For concrete, a corresponding survey on testing at high temperatures is given in the RILEM report<sup>[195]</sup>. In this report, existing test procedures are evaluated and test equipment is illustrated. Also included are guidelines for sample preparation, test conditions, and test procedures with reference to different mechanical material properties.

The most pronounced need for internationally standardized tests for mechanical material properties at elevated temperatures concerns compressive and tensile strength. Preference should be given to transient state tests, as this type of test is more representative of real fire exposure on structures and structural members than steady state tests. The next priority is to develop an internationally standardized package of tests to determine the strain components according to Equation (29), thermal strain, instantaneous stress-related strain, creep strain and transient strain. These tests would produce the input data on the mechanical fire behaviour of structural materials that is required for the models.

## Bibliography

- [1] CIB W141, A Conceptual Approach towards a Probability Based Design Guide on Structural Fire Safety, *Fire Safety Journal*, **6**, pp. 1-79, 1983
- [2] CIB W14, Design Guide — Structural Fire Safety, *Fire Safety Journal*, **9**, pp. 77-136, 1986
- [3] ENV 1991-2-2, *Eurocode 1 — Basis of Design and Actions on Structures — Part 2.2: Actions on Structures Exposed to Fire*, February, 1995
- [4] ENV 1992-1-2, *Eurocode 2 — Design of Concrete Structures — Part 1-2: General Rules — Structural Fire Design*, November, 1995
- [5] ENV 1993-1-2, *Eurocode 3 — Design of Steel Structures — Part 1-2: General Rules — Structural Fire Design*, September, 1995
- [6] ENV 1994-1-2, *Eurocode 4 — Design of Composite Steel and Concrete Structures — Part 1-2: General Rules — Structural Fire Design*, October, 1994
- [7] ENV 1995-1-2, *Eurocode 5 — Design of Timber Structures — Part 1-2: General Rules — Structural Fire Design*, November, 1994
- [8] ENV 1996-1-2, *Eurocode 6 — Design of Masonry Structures — Part 1-2: General Rules — Structural Fire Design*, June, 1995
- [9] ENV 199-1-2, *Eurocode 9 — Design of Aluminium Alloy Structures — Part 1-2: General Rules — Structural Fire Design*
- [10] KRUPPA, J., Performance-Based Code in Fire Resistance: A First Attempt by Eurocodes, *CIB International Conference on Performance-Based Codes and Fire Safety Design Methods*, Ottawa, September 24-26, 1996
- [11] ANDERBERG, Y. and THELANDERSSON, S., *Stress and Deformation Characteristics of Concrete at High Temperatures*, Lund Institute of Technology, Division of Structural Mechanics and Concrete Construction, Bulletin 54, Lund, 1976
- [12] SCHNEIDER, U., *Ein Beitrag zur Frage des Kriechens und der Relaxation von Beton unter hohen Temperaturen*, Institut für Baustoffe, Massivbau und Brandschutz der Technischen Universität Braunschweig, Heft 42, Braunschweig, 1979. Concrete at High Temperatures — A General Review, *Fire Safety Journal*, **13**, pp. 55-68, 1988
- [13] KHOURY, G. A. and GRAINGER, B. N., Strain Behaviour of Concrete under Various Temperature-Time Regimes, in 3rd International Workshop on *Behaviour of Concrete under Thermal and Hygral Gradients*, pp. 165-170, Weimar, 1992
- [14] HADVIG, S., *Charring of Wood in Building Fires — Practice, Theory, Instrumentation, Measurements*, Laboratory of Heating and Air Conditioning, Technical University of Denmark, Copenhagen, 1981
- [15] FREDLUND, B., *A Model for Heat and Mass Transfer in Timber Structures During Fire*, Lund Institute of Technology, Department of Fire Safety Engineering, Report LUTVDG/(TVBB-1003), Lund, 1988
- [16] WHITE, R. H. and NORDHEIM, E. V., Charring Rate of Wood for ASTM E 119 Exposure, *Fire Technology*, **28**(1), pp. 5-30, 1992
- [17] LIE, T. T., *Fire and Buildings*, Applied Science Publishers, London, 1972

- [18] PETERSSON, O., MAGNUSSON, S. E. and THOR, J., *Fire Engineering Design of Steel Structures*, Swedish Institute of Steel Construction, Publication No. 50, Stockholm, 1976 (Swedish Edition 1974)
- [19] PETERSSON, O., *Theoretical Design of Fire Exposed Structures*, Lund Institute of Technology, Division of Structural Mechanics and Concrete Construction, Bulletin 51, Lund, 1976
- [20] GUSTAFERRO, A. H. and MARTIN, L. D., *PCI Design for Fire Resistance of Precast Prestressed Concrete*, Prestressed Concrete Institute, PCI, Chicago, 1977
- [21] Institution of Structural Engineers, Concrete Society, *Design and Detailing of Concrete Structures for Fire Resistance*, Interim Guide, The Concrete Society, London, 1978
- [22] BARTHÉLEMY, B. and KRUPPA, J., *Résistance au Feu des Structures-Béton, Acier, Bois*, Édition Eyrolles, Paris, 1978
- [23] PETERSSON, O. and ÖDEEN, K., *Fire Engineering Design of Building Structures — Principles, Design Rules, Examples* (in Swedish), Liber Publishers, Stockholm, 1978
- [24] HARMATHY, T. Z., Design to Cope with Fully Developed Fires, in *Design of Buildings for Fire Safety*, ASTM Special Technical Publication STP 685, pp. 198-276, Washington, D.C., 1979
- [25] AISI, *Fire-Safe Structural Steel — A Design Guide*, American Iron and Steel Institute (AISI), Ohio, 1979
- [26] CSTB (Centre Scientifique et Technique du Bâtiment), *Méthode de Prévision par le Calcul du Comportement au Feu des Structures en Béton*, Document Technique Unifié, Paris, 1980
- [27] TWILT, L. and WITTEVEEN, J., *Fire Resistance of Steel Structures* (in Dutch), Staalcentrum Nederland, 1980
- [28] DOTREPPE, J. C., *Modèles Numérique pour la Simulation du Comportement au Feu des Structures en Acier et en Béton Armé*, Thèse d'Agrégation de l'Enseignement Supérieur, Université de Liège, 1980
- [29] ACI (American Concrete Institute), *Guide for Determining the Fire Endurance of Concrete Elements*, ACI Committee 216, ACI 216R-81, 1981
- [30] THRANE, E. J., *Fire Engineering Design of Building Structures* (in Norwegian), Tapir Forlag, Oslo, 1981
- [31] KORDINA, K. and MEYER-OTTENS, C., *Beton-Brandschutz-Handbuch*, Beton-Verlag, Düsseldorf, 1981
- [32] PETERSSON, O., MAGNUSSON, S. E. and THOR, J., *Rational Approach to Fire Engineering Design of Steel Buildings*, Lund Institute of Technology, Division of Building Fire Safety and Technology, Report LUTVDG/(TVBB-3002), Lund, 1981
- [33] MALHOTRA, H. L., *Design of Fire Resisting Structures*, Surrey University Press, London, 1982
- [34] CTICM (Centre Technique Industriel de la Construction Métallique), *Méthode de Prévision par le Calcul du Comportement au Feu des Structures en Acier*, *Revue Construction Métallique*, **3**, Paris, 1982
- [35] FORSÉN, N. E., *Theoretical Study on the Fire Resistance of Concrete Structures*, FCB-SINTEF, Report STF 65 A82062, Trondheim, 1982
- [36] ECCS (European Convention for Constructional Steelwork), *Calculation of the Fire Resistance of Load Bearing Elements and Structural Assemblies Exposed to the Standard Fire*, European Recommendations for the Fire Safety of Steel Structures, Elsevier, Amsterdam-Oxford-New York, 1983

- [37] BROZZETTI, J., LAW, M., PETERSSON, O. and WITTEVEEN, J., *Safety Concept and Design for Fire Resistance of Steel Structures*, IABSE Surveys, S-22/83, Zürich, 1983
- [38] ECCS (European Convention for Constructional Steelwork), *Design Manual on the European Recommendations for the Fire Safety of Steel Structures*, ECCS, Publication No. 35, Brussels, 1985
- [39] JÖNSSON, R. and PETERSSON, O., *Timber Structures and Fire*, Swedish Council for Building Research, Document D3:1985, Stockholm, 1985 (Swedish Edition 1983)
- [40] KIRBY, B. R., *Recent Developments and Applications in Structural Fire Engineering Design — A Review*, *Fire Safety Journal*, **11**, pp. 141-179, 1986
- [41] HASS, R., MEYER-OTTENS, C. and QUAST, U., *Verbundbau-Brandschutz-Handbuch*, Verlag W. Ernst & Sohn, Berlin, 1989
- [42] CARLING, O., *Fire Engineering Design of Timber Structures* (in Swedish), Swedish Institute for Wood Technology Research, Report I 9004018, Stockholm, 1990
- [43] CEB (Comité Euro-International du Béton), *Fire Design of Concrete Structures*, Bulletin d'Information N° 208, Lausanne, 1991
- [44] ANDERBERG, Y. and PETERSSON, O., *Fire Engineering Design of Concrete Structures* (in Swedish), Swedish Council for Building Research, T13:1992, Stockholm, 1992
- [45] International Iron and Steel Institute, *Fire Engineering Design for Steel Structures: State of the Art*, Brussels, 1993
- [46] HASS, R., MEYER-OTTENS, C. and RICHTER, E., *Stahlbau-Brandschutz-Handbuch*, Verlag W. Ernst & Sohn, Berlin, 1993
- [47] KORDINA, K., MEYER-OTTENS, C. and SCHEER, C., *Holz-Brandschutz-Handbuch*, Deutsche Gesellschaft für Holzforschung e.V., München, 1994 (First Edition 1983)
- [48] ISO 834, *Fire resistance tests — Elements of building construction*
- [49] PETERSSON, O., *Structural Fire Engineering Research Today and Tomorrow*, Acta Polytechnica Scandinavica, Ci 33, Stockholm, 1965
- [50] PETERSSON, O., *The Connection Between a Real Fire Exposure and the Heating Conditions According to Standard Fire Resistance Tests*, European Convention for Constructional Steelwork (ECCS), Chapter II, Publication CECM-III-74-2E. Also published as Bulletin 39, Lund Institute of Technology, Division of Structural Mechanics and Concrete Construction, Lund, 1975
- [51] WICKSTRÖM, U., *Natural Fires for Design of Steel and Concrete Structures — A Swedish Approach*, *International Symposium on Fire Engineering for Building Structures and Safety*, held in Melbourne on November 14-15, 1989, The Institution of Engineers, Australia, National Conference Publication No. 89/16, pp. 67-72, Melbourne, 1989
- [52] LAW, M., *A Relationship Between Fire Grading and Building Design and Contents*, Fire Research Note 877, Joint Fire Research Organization, Borehamwood, Herts., 1971
- [53] PETERSSON, O., *Structural Fire Protection*, Report of Group Session 5.2, CIB W14 Commission Meeting, Copenhagen, May 1978, *Fire and Materials*, **4**, pp. 1-16, 1980
- [54] KIRBY, B. R., WAINMAN, D. E., TOMLINSON, L. N., KAY, T. R. and PEACOCK, B. N., *Natural Fires In Large Scale Compartments — A British Steel Technical*, Fire Research Station Collaborative Project, British Steel Technical, Moorgate, Rotherham, 1994



- [55] LAW, M., A Review of Formulae for T-Equivalent, in *Fire Safety Science, Proceedings of the Fifth International Symposium*, pp. 985-996, International Association for Fire Safety Science, 1997
- [56] PETTERSSON, O., Rational Structural Fire Engineering Design, Based on Simulated Real Fire Exposure, 1994 Howard W. Emmons Invited Plenary Lecture, in *Fire Safety Science, Proceedings of the Fourth International Symposium*, pp. 3-26, International Association for Fire Safety Science, 1994
- [57] MAGNUSSON, S. E. and PETTERSSON, O., Functional Approaches — An Outline, in *Fire Safety in Buildings: Needs and Criteria*, CIB Symposium, held in Amsterdam, 2-3 June, 1977, Publication 48, CIB Proceedings, 120-145, Amsterdam, 1977
- [58] MAGNUSSON, S. E. and PETTERSSON, O., Rational Design Methodology for Fire Exposed Load Bearing Structures, *Fire Safety Journal*, **3**, pp. 227-241, 1980/81
- [59] PETTERSSON, O. and JÖNSSON, R., *Reliability Based Design of Fire Exposed Timber Structures — State of Art and Summary Design Guide*, Lund Institute of Science and Technology, Department of Fire Safety Engineering, Report LUTVDG/(TVBB-3040), Lund, 1988
- [60] SCHNEIDER, U., BUB, H. and KERSKEN-BRADLEY, M., Structural Fire Protection Levels for Industrial Buildings, *1980 Fall Convention*, American Concrete Institute, San Juan, Puerto Rico, 1980
- [61] HOSSER, D. and SCHNEIDER, U., *Sicherheitskonzept für brandschutztechnische Nachweise von Stahlbetonbauteilen nach der Wärmebilanztheorie*, Institut für Bautechnik, Berlin, 1980
- [62] MAGNUSSON, S. E., FRANTZICH, H. and HARADA, K., Fire Safety Design Based on Calculations: Uncertainty Analysis and Safety Verification, *Fire Safety Journal*, **27**(4), pp. 305-334, 1996
- [63] PETTERSSON, O., Reliability Based Design of Fire Exposed Concrete Structures, in *Contemporary European Concrete Research*, pp. 143-169, Stockholm, 1981
- [64] ASTM E 1355-92, *Standard Guide for Evaluating the Predictive Capability of Fire Models*, Philadelphia, 1992
- [65] ASTM E 1472-92, *Standard Guide for Documenting Computer Software for Fire Models*, Philadelphia, 1992
- [66] BEARD, A. N., Reliability and Computer Models, *Journal of Applied Fire Science*, **3**(3), pp. 273-279, 1993-94
- [67] LPC (Loss Prevention Council), *Compartment Fire Modelling*, Report on the State of the Art, LPC, London, 1994
- [68] BEARD, A. N., Fire Models and Design, *Fire Safety Journal*, **28**, pp. 117-138, 1997
- [69] SULLIVAN, P. J. E., TERRO, M. J. and MORRIS, W. A., Critical Review of Fire-Dedicated Thermal and Structural Computer Programs, *Journal of Applied Fire Science*, **3** (2), pp. 113-135, 1993-94
- [70] FRANSSON, J.-M., SCHLEICH, J. B., CAJOT, L.-G., TALAMONA, D., ZHAO, B., TWILT, L. and BOOTH, K., A Comparison Between Five Structural Fire Codes Applied to Steel Elements, (CEFICOSS, DIANA, LENAS-MT, SAFIR, and SISMEF), in *Fire Safety Science, Proceedings of the Fourth International Symposium*, pp. 1125-1136, International Association for Fire Safety Science, 1994
- [71] MAGNUSSON, S. E., *Probabilistic Analysis of Fire Exposed Steel Structures*, Lund Institute of Technology, Division of Structural Mechanics and Concrete Construction, Bulletin 27, Lund, 1974
- [72] HENKE, V., Zur Sicherheit schlanker Stahlbetonstützen im Brandfall, in *Koll. Brandverhalten von Bauteilen und Bauwerken*, Braunschweig, June 7-8, 1979, pp. 106-112, Braunschweig, 1979

- [73] FREDLUND, B., *A Computer Program for the Analysis of Timber Structures Exposed to Fire*, Lund Institute of Technology, Division of Building Fire Safety and Technology, Report LUTVDG/(TVBB-3020), Lund, 1985
- [74] WOESTE, F. E. and SCHAFFER, E. L., Second Moment Reliability Analysis of Fire Exposed Wood Joist Floor Assemblies, *Fire and Materials*, **3**, pp. 126-131, 1979
- [75] HARMATHY, T. Z. and MEHAFFEY, J. R., Post-flashover Compartment Fires: A Review, *Fire and Materials*, **7**, pp. 49-61, 1983
- [76] KAWAGOE, K. and SEKINE, T., *Estimation of Fire Temperature-Time Curve in Rooms*, Building Research Institute, Occasional Report No. 11, Tokyo, 1965. KAWAGOE, K., *Estimation of Fire Temperature-Time Curve in Rooms*, Building Research Institute, Research Paper No. 29, Tokyo, 1967
- [77] ÖDEEN, K., *Theoretical Study of Fire Characteristics in Enclosed Spaces*, Royal Institute of Technology, Division of Building Construction, Bulletin 19, Stockholm, 1963
- [78] MAGNUSSON, S. E. and THELANDERSSON, S., *Temperature-Time Curves for the Complete Process of Fire Development — A Theoretical Study of Wood Fuel Fires in Enclosed Spaces*, Acta Polytechnica Scandinavica, Ci 65, Stockholm, 1970
- [79] HARMATHY, T. Z., A New Look at Compartment Fires, Part I, *Fire Technology*, **8**, pp. 196-217, 1972, Part II, *Fire Technology*, **8**, pp. 326-351, 1972
- [80] BABRAUSKAS, V. and WILLIAMSON, R. B., *Post-flashover Compartment Fires*, University of California, Fire Research Group, Report No. UCB FRG 75-1, Berkeley, 1975. Post-flashover Compartment Fires: Basis of a Theoretical Model, *Fire and Materials*, **2**, pp. 39-53, 1978
- [81] THOMAS, P. H., Some Problem Aspects of Fully Developed Room Fires, in *Fire Standards and Safety*, ASTM Special Technical Publication STP 614, pp. 112-130, Washington, D.C., 1977
- [82] BABRAUSKAS, V., *COMPF2 — A Program for Calculating Postflashover Fire Temperatures*, National Bureau of Standards, Technical Note 991, Washington, D.C., 1979
- [83] SCHNEIDER, U. and HAKSEVER, A., *Wärmebilanzberechnungen für Brandräume mit unterschiedlichen Randbedingungen*. Technische Universität Braunschweig, Institut für Baustoffe, Massivbau und Brandschutz, Braunschweig, 1980
- [84] BABRAUSKAS, V., A Closed-form Approximation for Postflashover Compartment Fire Temperatures, *Fire Safety Journal*, **4**, pp. 63-73, 1981
- [85] NAKAYA, I. and AKITA, K., A Simulation Model for Compartment Fires, *Fire Safety Journal*, **5**, pp. 157-165, 1983
- [86] MAGNUSSON, S. E. and JÖNSSON, R., *Calculation of Gastemperature-Time Curves Using Recent Research Development*, Lund Institute of Technology, Division of Building Fire Safety and Technology, Lund, 1985
- [87] WICKSTRÖM, U., Application of the Standard Fire Curve for Expressing Natural Fires for Design Purposes, in *Fire Safety: Science and Engineering*, ASTM Special Technical Publication STP 882, pp. 145-159, Philadelphia, 1985
- [88] HARMATHY, T. Z., Postflashover Fires — An Overview of the Research at the National Research Council of Canada, *Fire Technology*, **22**, pp. 210-233, 1986
- [89] BIRK, D. M., *An Introduction to Mathematical Fire Modeling*, Technomic Publ. Co., Lancaster-Basel, 1991

- [90] THOMAS, P. H., HESELDEN, A. J. M. and LAW, M., *Fully-developed Compartment Fires — Two Kinds of Behaviour*, Fire Research Technical Paper No. 18, Ministry of Technology and Fire Offices Committee, Joint Fire Research Organization, HMSO, London, 1967
- [91] National Swedish Board of Physical Planning and Building, *Fire Engineering Design* (in Swedish), Comments on Swedish Building Code (SBN) No. 1976:1, Stockholm, 1976
- [92] PETTERSSON, O., The Parametric Temperature-Time Curves According to ENV 1991-2-2: 1995 E - A Summary Evaluation, *ISO/TC92/SC2/WG2 Document N261*, 1996
- [93] LAW, M., *Design for Fire Safety of Bare Exterior Structural Steel. 1. Theory and Validation. 2. State of the Art*, Ove Arup and Partners, London, 1977
- [94] AISI (American Iron and Steel Institute), *Fire-Safe Structural Steel — A Design Guide*, Washington, D.C., 1979
- [95] SÄRDQVIST, S., *Initial Fires — RHR, Smoke Production and CO Generation from Single Items and Room Fire Tests*, Lund University, Institute of Technology, Department of Fire Safety Engineering, Report LUTVDG/TVBB-3070-SE, Lund, 1993
- [96] KESKI-RAHKONEN, O., Breaking of Window Glass Close to Fire, *Fire and Materials*, **12**, pp. 61-69, 1988, and **15**, pp. 11-16, 1991
- [97] PAGNI, P. J. and JOSHI, A. A., Glass Breaking in Fires, in *Fire Safety Science, Proceedings of the Third International Symposium*, pp. 791-802, Elsevier Applied Science, London-New York, 1991
- [98] SKELLY, M. J., ROBY, R. J. and BEYLER, C. L., An Experimental Investigation of Glass Breakage in Compartment Fires, *Journal of Fire Protection Engineering*, **3**(1), pp. 25-34, 1991
- [99] HASSANI, S. K. S., SHIELDS, T. J. and SILCOCK, G. W. Thermal Fracture of Window Glazing: Performance of Glazing in Fire, *Journal of Applied Fire Science*, **4**(4), pp. 249-263, 1994-95
- [100] SINICAGLIA, P. E. and BARNETT, J. R., Development of a Glass Window Fracture Model for Zone-Type Computer Fire Codes, *Journal of Fire Protection Engineering*, **8**(3), pp. 101-118, 1997
- [101] PAGNI, P. J. and JOSHI, A. A., Fire-Induced Thermal Fields in Window Glass, *Fire Safety Journal*, **22**(1), pp. 25-56, 1994
- [102] COOPER, L. Y., Estimating the Environment and the Response of Sprinkler Links in Compartment Fires with Draft Curtains and Fusible Link-Actuated Ceiling Vents — Theory, *Fire Safety Journal*, **16**, pp. 137-163, 1990
- [103] DAVIS, W. D. and COOPER, L. Y., *Estimating the Environment and the Response of Sprinkler Links in Compartment Fires with Draft Curtains and Fusible Link-Actuated Ceiling Vents — Part II: User Guide for the Computer Code LAVENT*, US Department of Commerce, National Institute of Standards and Technology, NIST, Report NISTIR 89-4122, Gaithersburg, MD, 1989
- [104] HOLEN, J. and MAGNUSSEN, B. F., *KAMELEON FIRE E-3D. A Model for Enclosed Pool Fires*, SINTEF, Report STF 15 F90010, Trondheim, 1990
- [105] KUMAR, S. and COX, G., Radiation and Surface Roughness Effects in the Numerical Modelling of Enclosure Fires, in *Fire Safety Science, Proceedings of the Second International Symposium*, pp. 851-860, Hemisphere Publishing Corp., New York-Washington-Philadelphia-London, 1989
- [106] BILGER, R. W., Computational Field Models in Fire Research and Engineering, Invited Lecture, in *Fire Safety Science, Proceedings of the Fourth International Symposium*, pp. 95-110, International Association for Fire Safety Science, 1994

- [107] LEWIS, M. J., MOSS, M. B. and RUBINI, P. A., CFD Modelling of Combustion and Heat Transfer in Compartment Fires, in *Fire Safety Science, Proceedings of the Fifth International Symposium*, pp. 463-474, International Association of Fire Safety Science, 1997
- [108] FREDLUND, B., Modelling of Heat and Mass Transfer in Wood Structures During Fire, *Fire Safety Journal*, **20**, pp. 39-69, 1993
- [109] HARADA, K. and TERAJ, T., Heat and Mass Transfer in an Intensely Heated Mortar Wall, in *Fire Safety Science, Proceedings of the Third International Symposium*, pp. 781-790, Elsevier Applied Science, London-New York, 1991
- [110] HARADA, K. and TERAJ, T., Dependence of Thermal Responses of Composite Slabs Subjected to Fire on Cross-sectional Shapes, in *Fire Safety Science, Proceedings of the Fourth International Symposium*, pp. 1159-1170, International Association for Fire Safety Science, 1994
- [111] EHM, H., *Ein Beitrag zur rechnerischen Bemessung von brandbeanspruchten balkartigen Stahlbetonbauteilen*, Technische Universität Braunschweig, Dissertation, Braunschweig, 1967
- [112] ÖDEEN, K., *Fire Resistance of Concrete Double T Units*, Acta Polytechnica Scandinavica, Ci 48, Stockholm, 1968
- [113] KORDINA, K., SCHNEIDER, U., HAKSEVER, A. and KLINGSCH, W., *Zur Berechnung von Stahlbetonkonstruktionen im Brandfall*, Technische Universität Braunschweig, Institut für Baustoffe, Massivbau und Brandschutz, Braunschweig, 1975
- [114] RUDOLPHI, R. and MÜLLER, T., *ALGOL — Computerprogramm zur Berechnung zweidimensionaler instationärer Temperaturenverteilungen mit Anwendungen aus dem Brand- und Wärmeschutz*, BAM-Forschungsbericht Nr. 74, Berlin, 1980
- [115] BECKER, J., BIZRI, H. and BRESLER, B., *FIRES-T, A Computer Program for the Fire Response of Structures — Thermal*, University of California, Fire Research Group, Report No. UCB FRG 74-1, Berkeley, 1974
- [116] IDING, R., BRESLER, B. and NIZZAMUDDIN, Z., *FIRES-T3, A Computer Program for the Fire Response of Structures — Thermal (Three Dimensional Version)*, University of California, Fire Research Group, Report No. UCB FRG 77-15, Berkeley, 1977
- [117] WICKSTRÖM, U., *TASEF-2, A Computer Program for Temperature Analysis of Structures Exposed to Fire*, Lund Institute of Technology, Department of Structural Mechanics, Report No. 79-2, Lund, 1979
- [118] STERNER, E. and WICKSTRÖM, U., *TASEF — Temperature Analysis of Structures Exposed to Fire — User's Manual*, Swedish National Testing Institute, Fire Technology, SP Report 1990:5, Borås, 1990
- [119] ANDERBERG, Y. and PAULSSON, M., *TEMPCALC, A Computer Program for Temperature Analysis of Structures Exposed to Heat*, Institute of Fire Safety Design, Lund, 1985. *TEMPCALC III, A Computer Program for 3Dimensional Temperature Analysis of Structures Exposed to Heat*, Fire Safety Design, Lund, 1991
- [120] ANDERBERG, Y., *SUPER-TEMPCALC, A Commercial and User-friendly Computer Program with Automatic FEM-Generation for Temperature Analysis of Structures Exposed to Heat*, Fire Safety Design, Lund, 1991
- [121] GUSTAFSSON, H., CARLSSON, P. and WICKSTRÖM, U., *SUPER-TASEF — Temperature Analysis of Structures Exposed to Fire*, Swedish National Testing and Research Institute, SP Report, Borås, 1993
- [122] PALM, J., Temperature Analysis Using ABAQUS, *Fire Technology*, **30**(3), pp. 291-303, 1994
- [123] PETTERSSON, O., Practical Need of Scientific Material Models for Structural Fire Design — General Review, *Fire Safety Journal*, **13**, pp. 1-8, 1988

- [124] RUDOLPH, K., RICHTER, E., HASS, R. and QUAST, U., Principles for Calculation of Load Bearing and Deformation Behaviour of Composite Structural Elements Under Fire Action, in *Fire Safety Science, Proceedings of the First International Symposium*, pp. 301-310, Hemisphere Publishing Corporation, Washington, New York, London, 1986
- [125] RILEM, ANDERBERG, Y. (ed.), *Properties of Materials at High Temperatures — Steel*, Lund Institute of Technology, Division of Building Fire Safety and Technology, Report LUTVDG/(TVBB-3008), Lund, 1983
- [126] ANDERBERG, Y., *Predicted Fire Behaviour of Steels and Concrete Structures*, Lund Institute of Technology, Division of Building Fire Safety and Technology, Report LUTVDG/(TVBB-3011), Lund, 1983
- [127] DORN, E. J., Some Fundamental Experiments on High Temperature Creep, in *Creep and Fracture of Metals at High Temperatures*, pp. 89-138, HMSO, London, 1956
- [128] THOR, J., *Deformations and Critical Loads of Steel Beams Under Fire Exposure Conditions*, Lund Institute of Technology, Division of Structural Mechanics and Concrete Construction, Bulletin 35, Lund, 1973
- [129] HARMATHY, T. Z., Creep Deflection of Metal Beams in Transient Heating Processes, with Particular Reference to Fire, *Canadian Journal of Civil Engineering*, **3**(2), pp. 219-228, 1976
- [130] FURUMURA, F. and SHINOHARA, Y., *Inelastic Behaviour of Protected Steel Beams and Frames in Fire*, Research Laboratory of Engineering Materials, Tokyo, 1978
- [131] OKABE, T., FURUMURA, F., AVE, T. and SHINOHARA, Y., Elasto-Plastic-Creep Three-Dimensional Analysis of Steel H-Columns Subjected to High Temperatures, in *Fire Safety Science, Proceedings of the Third International Symposium*, pp. 741-750, Elsevier Applied Science, London, New York, 1991
- [132] SAAB, H. A., *Nonlinear Finite Element Analysis of Steel Frames in Fire Conditions*, Ph D Thesis, University of Sheffield, 1990
- [133] BAKER, D. J. and XIE, Y. M., Elasto-Plastic-Creep Analysis of Restrained Steel Columns Exposed to Fire, in *Fire Safety Science, Proceedings of the Fourth International Symposium*, pp. 1113-1124, International Association for Fire Safety Science, 1994
- [134] BEYER, R. and HARTMANN, B., Eine Untersuchung des Lastfalles Brand beim Stahlrahmen, in *Kolloquium für Finite Elemente in der Baupraxis*, Hannover, 1978
- [135] IDING, R. H. and BRESLER, B., *Effect of Fire Exposure on Steel Frame Buildings (Computer Model FASBUS II)*, Final Report WJE 78124, Wiss, Janney, Elstner and Associates, Inc., 1981
- [136] FORSÉN, N. E., *STEELFIRE — Finite Element Program for Non-Linear Analysis of Steel Frames Exposed to Fire, User's Manual*, Multiconsult A/S, Oslo, 1983
- [137] PETERSON, A., *Finite Element Analysis of Structures at High Temperatures, with Special Application to Plane Steel Beams and Frames*, Lund Institute of Technology, Division of Structural Mechanics, Report TVSM-1001, Lund, 1984
- [138] QUAST, U., HASS, R. and RUDOLPH, K., *STABA-F; A Computer Program for the Determination of Load Bearing and Deformation Behaviour of Uni-Axial Structural Elements under Fire Action*, Technische Universität Braunschweig, Institut für Baustoffe, Massivbau und Brandschutz, Braunschweig, 1984
- [139] SCHLEICH, J. B., *REFAO-CAFIR, Computer Assisted Analysis of the Fire Resistance of Steel and Composite Steel-Concrete Structures*, C.E.C. Research 7210 SA/502: Final Report EUR 10828 EN, Luxembourg, 1987

- [140] SAITO, H., UESUGI, H., YAMAGUCHI, M. and KODAIRA, A., Thermal Stress and Deformation of High Rise Buildings in Fire, in *Fire Safety Science, Proceedings of the Second International Symposium*, pp. 719-728, Hemisphere Publishing Corp., New York-Washington-Philadelphia-London, 1989
- [141] MIGITA, K., OKABE, T., FURUMURA, F., AVE, T. and KIM, W. J., Elasto-Plastic Creep Thermal Deformation Behavior of Multi-Storey Steel Frames Designed by the Plastic Method, in *Fire Safety Science, Proceedings of the Second International Symposium*, pp. 739-748, Hemisphere Publishing Corp., New York-Washington-Philadelphia-London, 1989
- [142] EBERG, E., AMDAHL, J., HOLMÅS, T. and HEKKELSTRAND, B., *Integrated Analysis of Offshore Structures Subjected to Fire*, SINTEF, Report STF 70 F92157, Trondheim, 1992
- [143] EL-RIMAWI, J. A., BURGESS, J. W. and PLANK, R. J., Model Studies of Composite Building Frame Behaviour in Fire, in *Fire Safety Science, Proceedings of the Fourth International Symposium*, pp. 1137-1148, International Association for Fire Safety Science, 1994
- [144] CHANDRASEKARAN, V. and MULCAHY, N. L., Analysis of Time of Collapse of Steel Columns Exposed to Fire, in *Fire Safety Science, Proceedings of the Fifth International Symposium*, pp. 1141-1152, International Association for Fire Safety Science, 1997
- [145] SCHNEIDER, U., MORITA, T. and FRANSEN, J.-M., A Concrete Model Considering the Load History Applied to Centrally Loaded Columns Under Fire Attack, in *Fire Safety Science, Proceedings of the Fourth International Symposium*, pp. 1101-1112, International Association for Fire Safety Science, 1994
- [146] THELANDERSSON, S., On the Multi-axial Behaviour of Concrete Exposed to High Temperature, *Nuclear Engineering and Design*, **75**(2), pp. 271-282, 1983
- [147] KORDINA, K., EHM, C. and SCHNEIDER, U., Effects of Biaxial Loading on the High Temperature Behaviour of Concrete, in *Fire Safety Science, Proceedings of the First International Symposium*, pp. 281-290, Hemisphere Publishing Corporation, Washington-New York-London, 1986
- [148] RILEM, SCHNEIDER, U. (ed.), *Properties of Materials at High Temperatures — Concrete*, Gesamthochschule Kassel, Department of Civil Engineering, Kassel, 1985
- [149] BECKER, J. M. and BRESLER, B., *FIRES-RC, A Computer Program for the Fire Response of Structures — Reinforced Concrete Frames*, University of California, Fire Research Group, Report No. UCB FRG 74-3, Berkeley, 1974
- [150] BRESLER, B., *Response of Concrete Frames to Fire*, Bresler, B. et al., *Limit State Behaviour of Reinforced Concrete Frames in Fire Environments*, University of California, Fire Research Group, Report No. UCB FRG 76-12, Berkeley, 1976
- [151] ANDERBERG, Y., *Fire Exposed Hyperstatic Concrete Structures — An Experimental and Theoretical Study*, Lund Institute of Technology, Division of Structural Mechanics and Concrete Construction, Bulletin 55, Lund, 1976
- [152] HAKSEVER, A., *Zur Frage des Trag- und Verformungsverhaltens ebener Stahlbetonrahmen im Brandfall*, Institut für Baustoffkunde und Stahlbetonbau der Technischen Universität Braunschweig, Heft 35, Braunschweig, 1977
- [153] KLINGSCH, W. and WITTBECKER, F. W., Structural Fire Engineering of Complex Frames by Means of Micro-Computer Application, in *Fire Safety Science, Proceedings of the Second International Symposium*, pp. 729-738, Hemisphere Publishing Corp., New York-Washington-Philadelphia-London, 1989
- [154] MORITA, T., WAKAMATSU, T., UESUGI, H. and SAITO, H., Analyses of Composite Beams and Frames at Elevated Temperature, in *Fire Safety Science, Proceedings of the Third International Symposium*, pp. 761-770, Elsevier Applied Science, London-New York, 1991

- [155] OHASHI, H., and KODAIRA, A., Calculation of Load and Deformation Behaviour of Structure Elements Taking into Account 3-Dimensional Heat Flow, in *Fire Safety Science, Proceedings of the Fifth International Symposium*, pp. 1021-1032, International Association for Fire Safety Science, 1997
- [156] NIZZAMUDDIN, Z., *Thermal and Structural Analysis of Reinforced Concrete Slabs in Fire Environments*, Thesis, University of California, Berkeley, 1976. - NIZZAMUDDIN, Z. and BRESLER, B., Fire Response of Concrete Slabs, *ASCE Proceedings, Journal of Structural Division*, 105:ST8, 1979
- [157] WANG, Y. C., Predicting the Behaviour of Reinforced Concrete Slabs at Elevated Temperature Using Finite Shell Element Analysis, in *Fire Safety Science, Proceedings of the Fourth International Symposium*, pp. 1077-1088, International Association for Fire Safety Science, 1994
- [158] HERTZ, K., *Design of Fire Exposed Concrete Structures*, Report No. 160. *Stress Distribution Factors*, Technical University of Denmark, Institute of Building Design, Report No. 158, Lyngby, 1981
- [159] HARMATHY, T. Z., *Fire Safety Design & Concrete*, Longman Scientific & Technical, Essex, 1994
- [160] ANDERBERG, Y. and FORSÉN, N. E., Fire Resistance of Concrete Structures, in *Nordic Concrete Research, Publication No. 1:1*, pp. 1-17, 1982
- [161] MEYER-OTTENS, C., *Zur Frage der Abplatzungen an Betonbauteilen aus Normalbeton bei Brandbeanspruchung*, Dissertation, Technische Universität, Braunschweig, 1972
- [162] ZHUKOV, V. V., Reasons of Explosive Spalling of Concrete by Fire (translation from Russian), *Beton i Zhelezobeton*, 3, 1976
- [163] HARMATHY, T. Z., Effect of Moisture on the Fire Endurance of Building Elements, in *Moisture in Materials in Relation to Fire Tests*, ASTM Special Technical Publication STP 385, pp. 74-94, Chicago, 1964
- [164] BENNET, J., CLAEISSON, J. and THELANDERSSON, S., *Calculation of Temperature, Moisture, and Pressure Distributions in Concrete Exposed to Fire*, Lund Institute of Technology, Department of Mathematical Physics and Division of Structural Mechanics, Lund, 1976
- [165] SAITO, *Bulletin of the Fire Prevention Society of Japan*, Vol. 15(1), January, 1965
- [166] ALI, F. A., CONNOLLY, R. and SULLIVAN, P. J. E., Spalling of High Strength Concrete at Elevated Temperatures, *Journal of Applied Fire Science*, 6(1), pp. 3-14, 1996-97
- [167] CONNOLLY, R. J., PURKISS, J. A. and MORRIS, W. A., The Spalling of Concrete in Fires, in *Fire Safety Science, Abstracts of First European Symposium*, III/12, 1995
- [168] GRAUERS, K., CEDERWALL, K. and GYLLTOFT, K., *Anchorage and Shear in Concrete Structures Exposed to Fire — A Literature Review*, Swedish National Testing and Research Institute, Fire Technology, SP Report 1994:02, Borås, 1994
- [169] FRANSSSEN, J. M. and BRULS, A., Design and Tests of Prestressed Concrete Beams, in *Fire Safety Science, Proceedings of the Fifth International Symposium*, pp. 1081-1092, International Association for Fire Safety Science, 1997
- [170] ZHAO, B. and KRUPPA, J., *Experimental and Numerical Investigation of Fire Behaviour of Steel and Concrete Composite Beams*, Symposium Paper, Centre Technique Industriel de la Construction Métallique (CTICM), Saint-Rémy-Lès-Chevreuse, France, 1996
- [171] GERHARDS, C. C., Effects of Moisture Content and Temperature on the Mechanical Properties: An Analysis of Immediate Effects, *Wood and Fiber*, 1, pp. 4-36, 1982
- [172] NORÉN, J. B., Failure of Structural Timber when Exposed to Fire, in *Proceedings of 1988 International Conference on Timber Engineering*, pp. 397-406, 1988

- [173] LAU, P. W. and BARRETT, J. D., Modelling Tension Strength Behaviour of Structural Lumber Exposed to Elevated Temperatures, in *Fire Safety Science, Proceedings of the Fifth International Symposium*, pp. 1177-1188, International Association for Fire Safety Science, 1997
- [174] SCHAFFER, E. L., *Elevated Temperature Effect on the Longitudinal Mechanical Properties of Wood*, Thesis, University of Wisconsin, Engineering Mechanics, Wisconsin, 1971
- [175] TAVAKKOL-KHAH, M. and KLINGSCH, W., Calculation Model for Predicting Fire Resistance Time of Timber Members, in *Fire Safety Science, Proceedings of the Fifth International Symposium*, pp. 1201-1211, International Association for Fire Safety Science, 1997
- [176] FREDLUND, B., *Structural Design of Fire Exposed Rectangular Laminated Wood Beams with Respect to Lateral Buckling*, Lund Institute of Technology, Department of Structural Mechanics, Report No. 79-5, Lund, 1979
- [177] The Swedish Board of Housing, Building and Planning, *National Application Documents, NAD(S), for SS-ENV 1992-1-2, Eurocode 2*, April, 1997; *SS-ENV 1993-1-2, Eurocode 3*, February, 1997; *SS-ENV 1994-1-2, Eurocode 4*, April, 1996
- [178] HÅVERSTAD, T. A., *Passive Fire Protection Subjected to Gas Explosion and Fire Loads*, NTH (The Norwegian Institute of Technology), Ph D dissertation 1989:24, Trondheim, 1989
- [179] NIST (National Institute of Standards and Technology), *Proceedings of Post-Earthquake Fire and Lifelines Workshop*, held at Long Beach, California, January 30-31, 1995, NIST Special Publication 889, 1995.
- [180] PETERSSON, O., *Post-Behaviour of Concrete Structures Subjected to Fire*, State of Art Report, Topic I.4, presented at IABSE-FIP-CEB-RILEM-IASS Colloquium Inter-Association Behaviour in Service of Concrete Structures, Liège 4-5-6 June, 1975. Also Lund Institute of Technology, Department of Structural Mechanics, Bulletin 40, Lund, 1975
- [181] ACI (American Concrete Institute), *Evaluation and Repair of Fire Damage to Concrete*, Special Publication, SP-92, Detroit, 1986
- [182] ACI (American Concrete Institute), *Evaluation and Repair of Fire Damage to Concrete*, Special Publication, SP-92, Detroit, 1986
- [183] CIB W14, *Repairability of Fire Damaged Structures*, CIB Report, Publication 111, Kassel, 1989
- [184] BAILEY, C. G., BURGESS, I. W. and PLANK, R. J., Analyses of the Effects of Cooling and Fire Spread on Steel-framed Buildings, *Fire Safety Journal*, **26**, pp. 273-293, 1996
- [185] BUCHANAN, A. H. and KING, A. B., Fire Performance of Gussset Connections in Glue-laminated Timber, *Fire and Materials*, **15**, pp. 137-143, 1991
- [186] KIRBY, B. R., The Behaviour of High-strength Grade 8.8 Bolts in Fire, *Journal of Constructional Steel Research*, **33**, pp. 3-38, 1995
- [187] NORÉN, J., Load-Bearing Capacity of Nailed Joints Exposed to Fire, *Fire and Materials*, **20**, pp. 133-143, 1996
- [188] CLEARY, T. G. and QUINTIERE, J. G., A Framework for Utilizing Fire Property Tests, in *Fire Safety Science, Proceedings of the Third International Symposium*, pp. 647-656, Elsevier Applied Science, London-New York, 1991
- [189] KARLSSON, B., *Modeling Fire Growth on Combustible Lining Materials in Enclosures*, Lund University, Department of Fire Safety Engineering, Report TVBB-1009, Lund, 1992



- [190] PARKER, W. J., A Procedure for Predicting the Heat Release Rate of Furniture Composites from Measurements on their Components, in *Fire Safety Science, Proceedings of the Fifth International Symposium*, pp. 129-140, International Association for Fire Safety Science, 1997
- [191] YAN, Z. and HOLMSTEDT, G., CFD and Experimental Studies of Room Fire Growth on Wall Lining Materials, *Fire Safety Journal*, **27**, pp. 201-238, 1996
- [192] LUNDKVIST, A., MÅRTENSSON, U. and PERSSON, B., *Measurement of Thermal Diffusivity in Materials at High Temperatures*, Swedish National Testing and Research Institute, Fire Technology, SP Report 1991-53, Borås, 1991
- [193] GRAUERS, K. and PERSSON, B., *Measurements of Thermal Properties in Building Materials at High Temperatures*, Swedish National Testing and Research Institute, Fire Technology, SP Report 1994:09, Borås, 1994
- [194] LOG, T. and GUSTAFSSON, S. E., Transient Plane Source (TPS) Technique for Measuring Thermal Transport Properties of Building Materials, *Fire and Materials*, **19**, pp. 43-49, 1995
- [195] RILEM, SCHNEIDER, U. and SCHWESINGER, P. (ed.), *Mechanical Testing of Concrete at High Temperatures*, Gesamthochschule Kassel, Department of Civil Engineering, Kassel, 1990
- [196] DIN 18230 (all parts), *Structural fire protection in industrial buildings*

---

---

**ICS 13.220.50**

Price based on 57 pages



# British Standards Institution (BSI)

BSI is the national body responsible for preparing British Standards and other standards-related publications, information and services.

BSI is incorporated by Royal Charter. British Standards and other standardization products are published by BSI Standards Limited.

## About us

We bring together business, industry, government, consumers, innovators and others to shape their combined experience and expertise into standards-based solutions.

The knowledge embodied in our standards has been carefully assembled in a dependable format and refined through our open consultation process. Organizations of all sizes and across all sectors choose standards to help them achieve their goals.

## Information on standards

We can provide you with the knowledge that your organization needs to succeed. Find out more about British Standards by visiting our website at [bsigroup.com/standards](http://bsigroup.com/standards) or contacting our Customer Services team or Knowledge Centre.

## Buying standards

You can buy and download PDF versions of BSI publications, including British and adopted European and international standards, through our website at [bsigroup.com/shop](http://bsigroup.com/shop), where hard copies can also be purchased.

If you need international and foreign standards from other Standards Development Organizations, hard copies can be ordered from our Customer Services team.

## Subscriptions

Our range of subscription services are designed to make using standards easier for you. For further information on our subscription products go to [bsigroup.com/subscriptions](http://bsigroup.com/subscriptions).

With **British Standards Online (BSOL)** you'll have instant access to over 55,000 British and adopted European and international standards from your desktop. It's available 24/7 and is refreshed daily so you'll always be up to date.

You can keep in touch with standards developments and receive substantial discounts on the purchase price of standards, both in single copy and subscription format, by becoming a **BSI Subscribing Member**.

**PLUS** is an updating service exclusive to BSI Subscribing Members. You will automatically receive the latest hard copy of your standards when they're revised or replaced.

To find out more about becoming a BSI Subscribing Member and the benefits of membership, please visit [bsigroup.com/shop](http://bsigroup.com/shop).

With a **Multi-User Network Licence (MUNL)** you are able to host standards publications on your intranet. Licences can cover as few or as many users as you wish. With updates supplied as soon as they're available, you can be sure your documentation is current. For further information, email [bsmusales@bsigroup.com](mailto:bsmusales@bsigroup.com).

## BSI Group Headquarters

389 Chiswick High Road London W4 4AL UK

## Revisions

Our British Standards and other publications are updated by amendment or revision.

We continually improve the quality of our products and services to benefit your business. If you find an inaccuracy or ambiguity within a British Standard or other BSI publication please inform the Knowledge Centre.

## Copyright

All the data, software and documentation set out in all British Standards and other BSI publications are the property of and copyrighted by BSI, or some person or entity that owns copyright in the information used (such as the international standardization bodies) and has formally licensed such information to BSI for commercial publication and use. Except as permitted under the Copyright, Designs and Patents Act 1988 no extract may be reproduced, stored in a retrieval system or transmitted in any form or by any means – electronic, photocopying, recording or otherwise – without prior written permission from BSI. Details and advice can be obtained from the Copyright & Licensing Department.

## Useful Contacts:

### Customer Services

**Tel:** +44 845 086 9001

**Email (orders):** [orders@bsigroup.com](mailto:orders@bsigroup.com)

**Email (enquiries):** [cservices@bsigroup.com](mailto:cservices@bsigroup.com)

### Subscriptions

**Tel:** +44 845 086 9001

**Email:** [subscriptions@bsigroup.com](mailto:subscriptions@bsigroup.com)

### Knowledge Centre

**Tel:** +44 20 8996 7004

**Email:** [knowledgecentre@bsigroup.com](mailto:knowledgecentre@bsigroup.com)

### Copyright & Licensing

**Tel:** +44 20 8996 7070

**Email:** [copyright@bsigroup.com](mailto:copyright@bsigroup.com)



...making excellence a habit.™