

PD IEC/TS 63066:2017



BSI Standards Publication

# Low-voltage docking connectors for removable energy storage units

### **National foreword**

This Published Document is the UK implementation of IEC/TS 63066:2017.

The UK participation in its preparation was entrusted by Technical Committee PEL/23, Electrical accessories, to Subcommittee PEL/23/4, Protected type plugs and sockets.

A list of organizations represented on this committee can be obtained on request to its secretary.

This publication does not purport to include all the necessary provisions of a contract. Users are responsible for its correct application.

© The British Standards Institution 2017.

Published by BSI Standards Limited 2017

ISBN 978 0 580 90190 4

ICS 29.120.30

**Compliance with a British Standard cannot confer immunity from legal obligations.**

This Published Document was published under the authority of the Standards Policy and Strategy Committee on 30 April 2017.

### **Amendments/corrigenda issued since publication**

<b>Date</b>	<b>Text affected</b>
-------------	----------------------

---



# TECHNICAL SPECIFICATION

---

**Low-voltage docking connectors for removable energy storage units**

INTERNATIONAL  
ELECTROTECHNICAL  
COMMISSION

---

ICS 29.120.30

ISBN 978-2-8322-4124-0

**Warning! Make sure that you obtained this publication from an authorized distributor.**

## CONTENTS

FOREWORD.....	5
INTRODUCTION.....	7
1 Scope.....	8
2 Normative references .....	8
3 Terms and definitions .....	9
4 General .....	11
4.1 General requirements .....	11
4.2 General notes on tests.....	11
4.3 General construction.....	11
4.4 Visual examination tests .....	12
4.5 Cable to be used.....	12
4.6 Voltage and current for test purposes .....	12
4.7 Type of accessories .....	12
5 Standard ratings .....	13
6 Classification of accessories.....	13
7 Marking .....	15
8 Dimensions.....	16
9 Protection against electric shock .....	16
10 Provision for earthing .....	17
11 Terminals and terminations.....	18
12 Interlocks.....	18
13 Resistance to ageing of rubber and thermoplastic material .....	19
14 General construction .....	19
15 Construction of accessories.....	19
16 Degrees of protection .....	19
17 Insulation resistance and dielectric strength .....	19
18 Mechanical endurance.....	19
19 Temperature rise .....	20
20 Mechanical strength .....	20
21 Screws, current-carrying parts and connections.....	20
22 Creepage distances, clearances and distances through sealing compound.....	20
23 Resistance to heat, to fire and to tracking.....	21
24 Conditional short-circuit current withstand test.....	21
25 Electromagnetic compatibility .....	21
26 Dynamic mechanical severities .....	21
26.1 Minimum degree of dynamic mechanical severities .....	21
26.2 Appropriate functionality .....	22
27 Electrical endurance .....	22
27.1 General requirements for accessories .....	22
27.2 Temperature burden for accessories .....	22
27.3 Damp heat for accessories.....	23
27.4 Contact resistance .....	23

28	Climatic endurance for contacts .....	23
28.1	General requirements for contacts .....	23
28.2	Thermal change for contacts .....	24
28.3	Dry heat for contacts .....	24
28.4	Corrosion resistance for contacts .....	24
28.5	Damp heat for contacts .....	24
28.6	Functionality for contacts .....	24
28.7	Shocks for contacts .....	24
29	Climatic endurance for bodies .....	25
29.1	General requirements for bodies .....	25
29.2	Dry heat for bodies .....	25
29.3	Cold resistance for bodies .....	25
29.4	Cold temperatures for bodies .....	25
30	Salt stress endurance .....	26
30.1	General requirements for accessories .....	26
30.2	Salt stress resistance .....	26
31	Operation with misalignments .....	26
31.1	Misalignment at normal operation .....	26
31.2	Misalignment after unmating .....	30
31.3	Misalignment by terminated wires .....	30
31.4	Mating process effected by misalignment .....	30
32	Environmental conditions .....	31
	Annex A (normative) Test cycle electric endurance .....	33
	Annex B (informative) Environmental performance classes for vehicles .....	34
	Annex C (informative) Examples for accessories on the market .....	35
C.1	General .....	35
C.2	Accessory example 1 .....	35
C.3	Accessory example 2 .....	38
C.4	Accessory example 3 .....	42
C.5	Accessory example 4 .....	44
C.6	Accessory example 5 .....	46
C.7	Accessory example 6 .....	48
	Bibliography .....	50
	Figure 1 – Diagram showing the use of the accessories .....	11
	Figure 2 – Orthogonal misalignment – front view .....	27
	Figure 3 – Angular misalignment – side view .....	27
	Figure 4 – Angular misalignment – top view .....	27
	Figure C.1 – Layout of accessory example 1 .....	36
	Figure C.2 – Accessory example 1 Type A .....	37
	Figure C.3 – Accessory example 1 Type B .....	38
	Figure C.4 – Layout of accessory example 2 .....	39
	Figure C.5 – Accessory example 2 Type A .....	40
	Figure C.6 – Accessory example 2 Type B .....	41
	Figure C.7 – Accessory example 3 Type A .....	43
	Figure C.8 – Accessory example 3 Type B .....	44

Figure C.9 – Drawings for accessory example 4 Type A.....	45
Figure C.10 – Drawings for accessory example 4 Type B.....	46
Figure C.11 – Drawings for accessory example 5 Type A.....	47
Figure C.12 – Drawings for accessory example 5 Type B.....	48
Figure C.13 – Drawings for accessory example 6 Type A.....	49
Figure C. 14 – Drawings for accessory example 6 Type B.....	49
Table 1 – General design and usage of accessories .....	12
Table 2 – Preferred rated currents .....	13
Table 3 – Short-time test currents .....	18
Table 4 – Mechanical endurance .....	20
Table 5 – Dimensions of misalignments .....	28
Table 6 – Combinations of misalignments .....	29
Table 7 – Environmental performance classes .....	31
Table 8 – Severities for environmental performance classes .....	32
Table B.1 – Severities for environmental performance classes for vehicles .....	34
Table C.1 – Parameters for accessory example 1 .....	36
Table C.2 – Parameters for accessory example 2 .....	39
Table C.3 – Parameters for accessory example 3 .....	42
Table C.4 – Parameters for accessory example 4 .....	45
Table C.5 – Parameters for accessory example 5 .....	47
Table C.6 – Parameters for accessory example 6 .....	48

## INTERNATIONAL ELECTROTECHNICAL COMMISSION

**LOW-VOLTAGE DOCKING CONNECTORS  
FOR REMOVABLE ENERGY STORAGE UNITS**

## FOREWORD

- 1) The International Electrotechnical Commission (IEC) is a worldwide organization for standardization comprising all national electrotechnical committees (IEC National Committees). The object of IEC is to promote international co-operation on all questions concerning standardization in the electrical and electronic fields. To this end and in addition to other activities, IEC publishes International Standards, Technical Specifications, Technical Reports, Publicly Available Specifications (PAS) and Guides (hereafter referred to as "IEC Publication(s)"). Their preparation is entrusted to technical committees; any IEC National Committee interested in the subject dealt with may participate in this preparatory work. International, governmental and non-governmental organizations liaising with the IEC also participate in this preparation. IEC collaborates closely with the International Organization for Standardization (ISO) in accordance with conditions determined by agreement between the two organizations.
- 2) The formal decisions or agreements of IEC on technical matters express, as nearly as possible, an international consensus of opinion on the relevant subjects since each technical committee has representation from all interested IEC National Committees.
- 3) IEC Publications have the form of recommendations for international use and are accepted by IEC National Committees in that sense. While all reasonable efforts are made to ensure that the technical content of IEC Publications is accurate, IEC cannot be held responsible for the way in which they are used or for any misinterpretation by any end user.
- 4) In order to promote international uniformity, IEC National Committees undertake to apply IEC Publications transparently to the maximum extent possible in their national and regional publications. Any divergence between any IEC Publication and the corresponding national or regional publication shall be clearly indicated in the latter.
- 5) IEC itself does not provide any attestation of conformity. Independent certification bodies provide conformity assessment services and, in some areas, access to IEC marks of conformity. IEC is not responsible for any services carried out by independent certification bodies.
- 6) All users should ensure that they have the latest edition of this publication.
- 7) No liability shall attach to IEC or its directors, employees, servants or agents including individual experts and members of its technical committees and IEC National Committees for any personal injury, property damage or other damage of any nature whatsoever, whether direct or indirect, or for costs (including legal fees) and expenses arising out of the publication, use of, or reliance upon, this IEC Publication or any other IEC Publications.
- 8) Attention is drawn to the Normative references cited in this publication. Use of the referenced publications is indispensable for the correct application of this publication.
- 9) Attention is drawn to the possibility that some of the elements of this IEC Publication may be the subject of patent rights. IEC shall not be held responsible for identifying any or all such patent rights.

The main task of IEC technical committees is to prepare International Standards. In exceptional circumstances, a technical committee may propose the publication of a technical specification when

- the required support cannot be obtained for the publication of an International Standard, despite repeated efforts, or
- the subject is still under technical development or where, for any other reason, there is the future but no immediate possibility of an agreement on an International Standard.

Technical specifications are subject to review within three years of publication to decide whether they can be transformed into International Standards.

IEC TS 63066, which is a technical specification, has been prepared by subcommittee 23H: Plugs, socket-outlets and couplers for industrial and similar applications, and for electric vehicles, of IEC technical committee 23: Electrical accessories.

The text of this technical specification is based on the following documents:

Enquiry draft	Report on voting
23H/372/DTS	23H/361/RVC

Full information on the voting for the approval of this technical specification can be found in the report on voting indicated in the above table.

This document has been drafted in accordance with the ISO/IEC Directives, Part 2.

In this document, the following print types are used:

- requirements proper: in roman type;
- *test specifications: in italic type;*
- explanatory matter: in smaller roman type.

The committee has decided that the contents of this document will remain unchanged until the stability date indicated on the IEC website under "<http://webstore.iec.ch>" in the data related to the specific document. At this date, the document will be

- reconfirmed,
- withdrawn,
- replaced by a revised edition, or
- amended.

A bilingual version of this publication may be issued at a later date.



## INTRODUCTION

Pluggable energy storage technology has a large demand and perspective in certain areas. With the advent of electric vehicles, energy storage units for renewable energy and other applications, guidance is needed to ensure safe and reliable operation, interoperability, environmental protection and energy efficiency. The industry needs such a document to promote the technology development and popularization of pluggable energy storage technology.

Compared to other accessories, several specific items are considered. The mating process may not have haptic support by the operator to find the correct position between the two parts of the connector. The mating process may have a mechanical feed which precludes the finding of the correct position between the two parts of the connector. To overcome these issues, the design of the accessories may consist partly of moveable parts to compensate a mechanical feed and tolerances.

## LOW-VOLTAGE DOCKING CONNECTORS FOR REMOVABLE ENERGY STORAGE UNITS

### 1 Scope

This document applies to docking connectors (hereinafter referred to as accessories) incorporated in or fixed to electrical equipment, intended to connect removable energy storage units to a dedicated electric power conversion unit, to an energy consuming unit or to another energy storage unit.

These accessories are intended for DC and may include an earth<sup>1</sup> contact and/or optional auxiliary contacts for signaling and data. These accessories have a rated current of up to 800 A and rated operating voltages not exceeding 1 000 V DC.

These accessories are not suitable for mating or unmating under load. These accessories are intended to be installed by instructed persons (IEC 60050-195:1998, 195-04-02) or skilled persons (IEC 60050-195:1998, 195-04-01) only.

The list of preferred ratings is not intended to exclude other ratings.

This document applies to accessories for use under environmental conditions as described in Clause 32.

These accessories are intended to be connected to current carrying parts in copper or copper alloy only, plated or not plated.

This document also applies to accessories intended to be used at extra-low voltage.

In locations where special conditions prevail, for example on board vehicles, additional requirements may apply.

These accessories are intended to be used with a specific charging system.

NOTE For conditions other than operation, additional requirements could be applicable, for instance IEC 62133 and the UN Recommendations on the Transport of Dangerous Goods section 38.338.3.

### 2 Normative references

Clause 3 of IEC 60309-1:1999, IEC 60309-1:1999/AMD1:2005 and IEC 60309-1:1999/AMD2:2012 applies, except as follows:

*Addition of the following new references:*

IEC 60068-2-1, *Environmental testing – Part 2-1: Tests – Test A: Cold*

IEC 60068-2-2, *Environmental testing – Part 2-2: Tests – Test B: Dry heat*

IEC 60068-2-14, *Environmental testing – Part 2-14: Tests – Test N: Change of temperature*

---

<sup>1</sup> In some countries, the term ground is used instead of earth.

IEC 60068-2-30, *Environmental testing – Part 2-30: Tests – Test Db: Damp heat, cyclic (12 h + 12 h cycle)*

IEC 60068-2-38, *Environmental testing – Part 2-38: Tests – Test Z/AD: Composite temperature/humidity cyclic test*

IEC 60068-2-52, *Environmental testing – Part 2: Tests – Test Kb: Salt mist, cyclic (sodium chloride solution)*

IEC 60068-2-60, *Environmental testing – Part 2-60: Tests – Test Ke: Flowing mixed gas corrosion test*

IEC 60309-1:1999, *Plugs, socket-outlets and couplers for industrial purposes – Part 1: General requirements*

IEC 60309-1:1999/AMD1:2005

IEC 60309-1:1999/AMD2:2012

IEC 60352 (all parts), *Solderless connections*

IEC 60417, *Graphical symbols for use on equipment* (available at <http://www.graphical-symbols.info/equipment>)

IEC 61140:2016, *Protection against electric shock – Common aspects for installation and equipment*

IEC 61373:2010, *Railway applications – Rolling stock equipment – Shock and vibration tests*

ISO/IEC TR 29106:2007, *Information technology – Generic cabling – Introduction to the MICE environmental classification*

ISO/IEC TR 29106:2007/AMD1:2012

### **3 Terms and definitions**

Clause 2 of IEC 60309-1:1999, IEC 60309-1:1999/AMD1:2005 and IEC 60309-1:1999/AMD2:2012 applies, except as follows:

*Addition of the following new terms and definitions:*

#### **3.1**

##### **docking connector**

accessory where the two complementary accessories are equipped with guiding means allowing their connection without the haptic support of an operator

#### **3.2**

##### **unmated condition**

position of the accessory without any contact between both parts

#### **3.3**

##### **mated condition**

service condition and position where the two parts of the accessory are in a position as described in the relevant standard sheet

#### **3.4**

##### **guiding means**

mechanical structure intended to ensure the proper alignment of the two complementary accessories before their mating

**3.5****energy storage unit**

unit, which includes accessories, multiple batteries or other chargeable cells arranged in a way to store electrical energy

Note 1 to entry: This may also include supporting means for charging, storage, interlocking and discharging.

**3.6****removable energy storage unit**

energy storage unit, which can be easily detached and inserted into a rack to establish the electrical connection with an accessory

**3.7****rack**

mechanical structure intended to incorporate one or more removable energy storage units

**3.8****electric power conversion unit**

device converting electric energy from one form to another, converting between AC and DC, or changing the voltage or frequency, or a combination of these

**3.9****shutter**

movable part incorporated into an accessory arranged to automatically shield at least the live contacts when the complementary accessory is withdrawn

[SOURCE: IEC 60884-1:2002/AMD2:2013, 3.27, modified – 'socket-outlet' and 'plug' are replaced by 'accessory', 'automatically' is deleted and 'complementary' is added]

**3.10****superordinate system**

overall technical system as a set of components or systems with relationships between the components or systems and between their attributes

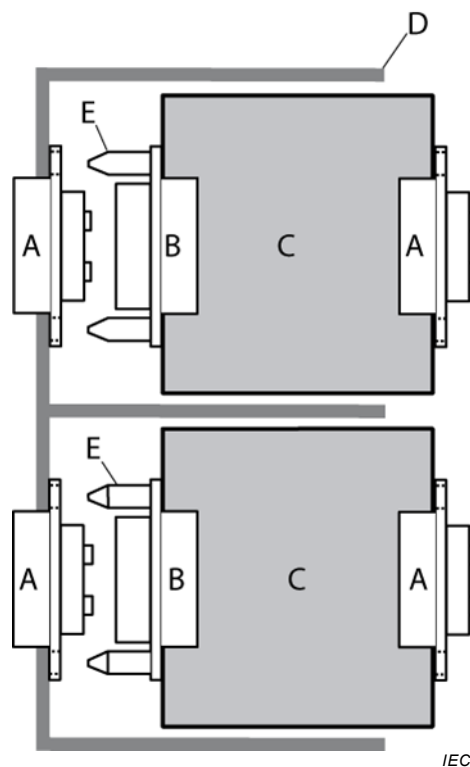
**Key**

- A docking accessories type A
- B complementary docking accessories type B
- C removable energy storage units
- D rack
- E guiding means

**Figure 1 – Diagram showing the use of the accessories**

## 4 General

Clause 4 of IEC 60309-1:1999, IEC 60309-1:1999/AMD1:2005 and IEC 60309-1:1999/AMD2:2012 applies, except as follows:

### 4.1 General requirements

*Replacement of the fourth paragraph with:*

Accessories shall have a minimum degree of protection as indicated in Table 8, test variable TV1.

### 4.2 General notes on tests

Subclause 4.2 of IEC 60309-1:1999, IEC 60309-1:1999/AMD1:2005 and IEC 60309-1:1999/AMD2:2012 applies.

### 4.3 General construction

Different possibilities for the movement, adjustment and mating of components and accessories are stated in Table 1.

**Table 1 – General design and usage of accessories**

Case	Accessory Type A		Accessory Type B		Removable energy storage unit
	Possibility of movement relative to the structure of the rack or removable energy storage unit	Self-adjustment to the nominal position of the movable part after disconnecting	Possibility of movement relative to the structure of the removable energy storage unit	Self-adjustment to the nominal position of the movable part after disconnecting	Possibility of movement relative to the rack
1	Not movable	No	Not movable	No	Not movable
2	Not movable	No	Not movable	No	Movable
3	Not movable	No	Movable	No	Not movable
4	Not movable	No	Movable	Yes	Not movable
5	Movable	Yes	Not movable	No	Not movable
6	Movable	No	Not movable	No	Not movable

NOTE Other combinations are not excluded.

Annex C shows examples of accessories.

#### 4.4 Visual examination tests

If required by a test and unless otherwise specified, visual examination tests shall be performed with the naked eye. The following characteristics shall be checked:

- quality of assembling before test;
- marking;
- materials;
- marks of corrosion;
- colour, change of colour after the test;
- impurities, contamination, particles of abrasion after the test;
- damages, holes, cracks;
- damaged and loosened parts;
- status and location of lubrication and glues.

*No noticeable problems shall occur which could impair normal operation or show a deviation from this standard.*

#### 4.5 Cable to be used

Unless otherwise specified by the manufacturer, the following stranded cable shall be used for the power contacts: H07V.

#### 4.6 Voltage and current for test purposes

As deviation from the referred test standards, tests may be performed with AC or DC.

#### 4.7 Type of accessories

Requirements mentioned for accessories called plug or inlet are applicable for accessories Type B.

Requirements mentioned for accessories called socket outlet or connector are applicable for accessories Type A.

## 5 Standard ratings

Clause 5 of IEC 60309-1:1999, IEC 60309-1:1999/AMD1:2005 and IEC 60309-1:1999/AMD2:2012 applies, except as follows:

### 5.2 Replacement:

Preferred rated currents are given in Table 2.

**Table 2 – Preferred rated currents**

Rated current A
16
32
63
125
250
315
400
630
800

*Additional subclause:*

**5.3** Rated current for data, communication and control circuit purposes is 2 A.

Rated voltage for data, communication and control circuit purposes is 30 V or less according to the manufacturer's specification.

## 6 Classification of accessories

**6.1** Accessories are classified according to degree of protection as tested in Clause 16.

**6.2** Accessories are classified according to earthing facilities:

- accessories without earthing contact;
- accessories with earthing contact.

**6.3** Accessories are classified according to the method of connecting the cable:

- rewirable accessories;
- non-rewirable accessories.

**6.4** Accessories are classified according to interlocking facilities:

- accessories without interlock;
- accessories with mechanical interlock (with latching device);

- accessories with electrical interlock (without latching device);
- accessories with latching device and electrical interlock.

**6.5** Accessories are classified according to the type of terminals:

- screw type terminals;
- screwless type terminals;
- insulation piercing terminals.

**6.6** Accessories are classified according to the type of conductors for screwless type and insulation piercing terminals

- for solid conductors only;
- for rigid (both solid and stranded) conductors only;
- for rigid (both solid and stranded) and flexible conductors.

**6.7** Accessories are classified according to accessibility to live parts when unmated:

- accessories providing for less than IPXXB;
- accessories providing for IPXXB;
- accessories providing for IPXXD.

**6.8** Accessories are classified according to locking facilities:

- non-lockable accessories;
- lockable accessories.

**6.9** Accessories are classified according to the presence of shutter(s):

- accessories without shutter(s);
- accessories with shutter(s).

**6.10** Accessories are classified according to their environmental performance class in Table 7:

- accessories tested for use in environmental performance class C;
- accessories tested for use in environmental performance class O;
- accessories tested for use in environmental performance class I;
- accessories tested for use in environmental performance class X.
- accessories tested for use in environmental performance class R;
- accessories tested for use in environmental performance class T.

**6.11** Accessories are classified according to the case of use according Table 1:

- accessories intended for use in case 1;
- accessories intended for use in case 2;
- accessories intended for use in case 3;
- accessories intended for use in case 4;
- accessories intended for use in case 5;
- accessories intended for use in case 6;
- accessories intended for use in other cases.



**6.12** Accessories are classified according to the type defined in Figure 1:

- accessories of Type A;
- accessories of Type B.

## 7 Marking





**7.1** Accessories shall be marked with:

- rated current(s) in amperes;
- rated operating voltage(s) or range(s) in volts;
- either the name or trade mark of the manufacturer or of the responsible vendor;
- type reference, which may be a catalogue number;
- degree of protection;
- symbol indicating the position of the earthing contact or the means used for interchangeability, if any.

NOTE Optionally, the insulation voltage can be marked.

*Compliance is checked by inspection.*

**7.2** When symbols are used, they shall be as follows:

A	amperes	
V	volts	
	direct current	IEC 60417-5031 (2002-10)
	(preferred) protective earth; protective ground	IEC 60417-5019 (2006-08)
and or	earth; ground	IEC 60417-5017 (2006-08)
		
	Plus; positive polarity	IEC 60417-5005 (2002-10)
	Minus; negative polarity	IEC 60417-5006 (2002-10)
IPXX	(relevant figures) degree of protection according to IEC 60529	

*Compliance is checked by inspection.*

**7.3** The marking for either the name or trade mark of the manufacturer or the responsible vendor and the type reference, catalogue number or designation shall also be in a place which is visible before installation of the accessory.

The marking for the maximum rated operating voltage range and rated current shall be in a place which is visible before installation of the accessory. The marking for either the name or trademark of the manufacturer or the responsible vendor and the type reference, catalogue number or designation shall be in a place which is visible before installation of the accessory. It need not be visible after installation.

*Compliance is checked by inspection.*

**7.4** For rewirable accessories, the contacts shall be indicated by the following symbols:

- the symbols + and – and the symbol  for protective earth if any;
- other contacts as indicated in the relevant standard sheet.

These symbols shall be placed close to the relevant terminals; they shall not be placed on screws, removable washers or other removable parts.

*Compliance is checked by inspection.*

For rewirable accessories, wiring instructions shall be provided.

*Compliance is checked by inspection.*

**7.5** Pre-wired accessories shall be provided with information to identify the conductors at the loose end.

*Compliance is checked by inspection.*

## **8 Dimensions**

Clause 8 of IEC 60309-1:1999, IEC 60309-1:1999/AMD1:2005 and IEC 60309-1:1999/AMD2:2012 applies, except as follows:

**8.3** *Replacement of the last paragraph with the following:*

*Compliance is checked by inspection and the following manual test:*

*Insertion of the appropriate accessory is tested for 1 min with a force of 150 N for accessories with a rated current not exceeding 16 A, or 250 N for other accessories.*

*Where the use of elastomeric or thermoplastic material is likely to influence the result of the test, it is carried out at an ambient temperature of  $(50 \pm 2)$  °C, both the accessories being conditioned at this temperature.*

## **9 Protection against electric shock**

Clause 9 of IEC 60309-1:1999, IEC 60309-1:1999/AMD1:2005 and IEC 60309-1:1999/AMD2:2012 applies except as follows:

**9.1** *Replacement:*

Live contacts, when they are wired as in normal use, and when they are in partial or complete engagement with the complementary accessories, shall not be accessible.

This requirement does not apply to contacts and conductors used for signal, data, communication and control circuits operated according to IEC 61140:2016, 5.2.6.

In addition, it shall not be possible to make contact between live contacts and any other conductive part which is accessible. This shall be ensured by the superordinate systems where the accessories are embedded.

If the accessory is rated as having accessibility to live parts less than IPXXB, additional measures by the superordinate system according to IEC 61140:2016, 5.2 shall be introduced, except 5.2.6 and 5.2.8.

The measures to check the compliance are part of the intended standard for the superordinate system.

*Compliance is checked by inspection and, if necessary, by a test on the sample wired as in normal use.*

*The standard test finger (IEC 60309-1:1999, IEC 60309-1:1999/AMD1:2005 and IEC 60309-1:1999/AMD2:2012, Figure 2) is applied in every possible position, an electrical indicator, with a voltage not less than 40 V, being used to show contact with the relevant part.*

*There shall be no contact.*

## **9.2 Replacement:**

The contact sequence during the connection process shall be:

- guiding means (if any),
- earth contact PE (if any),
- power, signal, control contacts and screening (if any),
- the contact which establishes the communication shall mate at the latest in order to release the current flow.

The unmating process applies in the reversed order.

## **10 Provision for earthing**

Clause 10 of IEC 60309-1:1999, IEC 60309-1:1999/AMD1:2005 and IEC 60309-1:1999/AMD2:2012 applies, except as follows:

### **10.3 Replacement:**

Protective earthing contacts shall comply with the test requirements in either 10.3 a) or 10.3 b) to 10.3 d), as specified by the manufacturer.

- a) Protective earthing contacts shall be capable of carrying a current equal to that specified for the phase contacts without overheating.

*Compliance is checked by the test of Clause 19.*

- b) The assembly of mating accessories with protective earthing contacts shall carry the current specified in Table 3 for the time specified in Table 3. The current shall be based on the minimum size equipment protective earthing conductor for the current rating of the accessory. The components in the protective earthing path shall not crack, break, or melt.

**Table 3 – Short-time test currents**

Rating of the accessory equal or less	Minimum size for protective earthing copper conductor		Time	Test current
	mm <sup>2</sup>	AWG		
A			s	A
16	4	12	4	470
32	6	10	4	750
63	10	8	4	1 180
125	16	6	6	1 530
250	25	4	6	2 450
400	35	2	6	3 900
800	50	1	6	4 900

NOTE For accessories' ratings less than 10 A in Table 3, test current is based on the smallest size equipment protective earthing conductor permitted or can be determined by linear approximation of rated current (or 120 A per 1 mm<sup>2</sup>), whichever is greater.

- c) The mating accessories shall be mounted and assembled as intended. A protective earthing conductor of the minimum intended size, not less than 0,6 m long, shall be connected to the protective earthing terminal of each accessory, with the terminals employed to hold the conductor tightened using a torque as specified by the manufacturer. Accessories of type A and B shall be wired with the minimum allowable size copper conductor. The test current shall be passed through the mating accessories and protective earthing wires in series.
- d) After having carried the current specified in 10.3 b), continuity shall exist on the test assembly when measured between the protective earthing conductors. Any indicating device such as an ohmmeter, battery-and-buzzer combination, or the like, may be used to determine whether continuity exists.

*Compliance is checked by inspection and test.*

## 11 Terminals and terminations

Clause 11 of IEC 60309-1:1999, IEC 60309-1:1999/AMD1:2005 and IEC 60309-1:1999/AMD2:2012 applies, except as follows:

*Additional subclause:*

**11.8** For other terminations, the relevant tests from IEC 60352 series applies.

## 12 Interlocks

Clause 12 of IEC 60309-1:1999, IEC 60309-1:1999/AMD1:2005 and IEC 60309-1:1999/AMD2:2012 applies.

### 13 Resistance to ageing of rubber and thermoplastic material

Clause 13 of IEC 60309-1:1999, IEC 60309-1:1999/AMD1:2005 and IEC 60309-1:1999/AMD2:2012 applies.

### 14 General construction

Clause 14 of IEC 60309-1:1999, IEC 60309-1:1999/AMD1:2005 and IEC 60309-1:1999/AMD2:2012 applies.

### 15 Construction of accessories

Clause 15 of IEC 60309-1:1999, IEC 60309-1:1999/AMD1:2005 and IEC 60309-1:1999/AMD2:2012 applies to accessories type A, except as follows: Subclauses 15.1, 15.3, 15.7 and 15.8 do not apply.

Clause 17 of IEC IEC 60309-1:1999, IEC 60309-1:1999/AMD1:2005 and IEC 60309-1:1999/AMD2:2012 applies to accessories type B.

### 16 Degrees of protection

Clause 18 of IEC 60309-1:1999, IEC 60309-1:1999/AMD1:2005 and IEC 60309-1:1999/AMD2:2012 applies with the complementary accessory in engagement.

Accessories shall have the minimum degrees of protection as indicated in Table 8, test variable TV1.

The degree of protection shall apply to accessories in complete engagement only. The requirements for other conditions depend on the superordinate system.

*Compliance is checked by the appropriate tests of IEC 60309-1:1999, IEC 60309-1:1999/AMD1:2005 and IEC 60309-1:1999/AMD2:2012, Clause 18.*

### 17 Insulation resistance and dielectric strength

Clause 19 of IEC 60309-1:1999, IEC 60309-1:1999/AMD1:2005 and IEC 60309-1:1999/AMD2:2012 applies.

### 18 Mechanical endurance

Accessories shall withstand, without excessive wear or other harmful effect, the mechanical, stress occurring in normal use.

*Type A and Type B accessories are mated and unmated at a rate of 7,5 strokes per minute.*

*After each 500 strokes, contacts pins, if any, are wiped with a piece of dry cloth or the equivalent dry cleaning maintenance operation is performed, as stated in the manufacturer's instructions.*

*During the test, the contacts of the accessories shall not be adjusted, lubricated or otherwise conditioned.*

The number of cycles according to the relevant standard sheet or Annex C applies without load. In other cases, the number of cycles is given in Table 4.

After the test, the samples shall show:

- no wear impairing the further use of the accessory or of its interlock, if any;
- no deterioration of enclosures or barriers;
- no damage to the entry holes of the contacts that might impair proper working;
- no loosening of electrical or mechanical connections;
- no seepage of sealing compound.

The samples shall then withstand a dielectric strength test made in accordance with Clause 17, the test voltage, however, being decreased by 500 V for accessories having an insulation voltage exceeding 50 V.

NOTE The humidity treatment is not repeated before the dielectric strength test of Clause 17.

**Table 4 – Mechanical endurance**

Rating	Number of cycles
A	
Up to 29	5 000
30 to 59	2 000
60 to 99	2 000
100 to 199	500
200 to 250	250
251 to 800	NA

## 19 Temperature rise

Clause 22 of IEC 60309-1:1999, IEC 60309-1:1999/AMD1:2005 and IEC 60309-1:1999/AMD2:2012 applies.

## 20 Mechanical strength

Clause 24 of IEC 60309-1:1999, IEC 60309-1:1999/AMD1:2005 and IEC 60309-1:1999/AMD2:2012 applies with Table 8, test variable TV3 instead of the impact energy in Table 12 from IEC 60309-1:1999, IEC 60309-1:1999/AMD1:2005 and IEC 60309-1:1999/AMD2:2012 Before testing, the accessories shall be placed in a refrigerator at a temperature of Table 8, test variable TV4.

## 21 Screws, current-carrying parts and connections

Clause 25 of IEC 60309-1:1999, IEC 60309-1:1999/AMD1:2005 and IEC 60309-1:1999/AMD2:2012 applies.

## 22 Creepage distances, clearances and distances through sealing compound

Clause 26 of IEC 60309-1:1999, IEC 60309-1:1999/AMD1:2005 and IEC 60309-1:1999/AMD2:2012 applies.

## 23 Resistance to heat, to fire and to tracking

Clause 27 of IEC 60309-1:1999, IEC 60309-1:1999/AMD1:2005 and IEC 60309-1:1999/AMD2:2012 applies.

## 24 Conditional short-circuit current withstand test

Clause 29 of IEC 60309-1:1999, IEC 60309-1:1999/AMD1:2005 and IEC 60309-1:1999/AMD2:2012 applies, except as follows:

Subclause 29.1 of IEC 60309-1:1999, IEC 60309-1:1999/AMD1:2005 and IEC 60309-1:1999/AMD2:2012.

### *Replacement:*

Accessories shall have the minimum prospective short-circuit current and time according to Table 3 or of higher value specified by the manufacturer. An optional higher rating should consider the application.

*Compliance is checked by testing each accessory with a new complementary accessory complying with this standard.*

Subclause 29.2 of IEC 60309-1:1999, IEC 60309-1:1999/AMD1:2005 and IEC 60309-1:1999/AMD2:2012.

### *Replacement of the third paragraph with the following:*

*The short-circuit protective device shall be a "gG" type fuse for general application complying with the requirements of IEC 60269-1 and IEC 60269-2 and having ratings identical to those of the accessory or of a higher current or voltage rating specified by the manufacturer.*

## 25 Electromagnetic compatibility

Clause 30 of IEC 60309-1:1999, IEC 60309-1:1999/AMD1:2005 and IEC 60309-1:1999/AMD2:2012 applies.

## 26 Dynamic mechanical severities

### 26.1 Minimum degree of dynamic mechanical severities

Accessories shall withstand a minimum degree of dynamic mechanical severities.

*The tests are made on accessories fitted with the cables or conduits for which they are designed, screwed glands and fixing screws of bodies and covers being tightened with a torque equal to that of the tests of IEC 60309-1:1999, IEC 60309-1:1999/AMD1:2005 and IEC 60309-1:1999/AMD2:2012, 24.5 or 25.1, as appropriate.*

*Accessories are mounted as in normal use. Screwed caps or lids, if any, are tightened as in normal use. Accessories are mounted in a position as intended by the assembly. Tests are conducted with any doors, access panels, covers, etc., provided in the assembly both in the unmated, open, and closed positions. Accessories are placed in the most unfavourable position.*

## 26.2 Appropriate functionality

### 26.2.1 Accessories shall have an appropriate functionality.

*Compliance is checked by inspection and by the test of IEC 61373 as described in 26.2.2 and 26.2.3.*

*The tests are made on accessories fitted with the cables or conduits for which they are designed, screwed glands and fixing screws of bodies and covers being tightened with a torque equal to that of the tests of IEC 60309-1:1999, IEC 60309-1:1999/AMD1:2005 and IEC 60309-1:1999/AMD2:2012, 24.5 or 25.1, as appropriate.*

*Accessories are mounted as in normal use. Screwed caps or lids, if any, are tightened as in normal use. Accessories are mounted in a position as intended by the assembly. Tests are conducted with any doors, access panels, covers, etc., provided in the assembly both in the unmated, open, and closed positions. Accessories are placed in the most unfavourable position.*

### 26.2.2 Accessories shall withstand fatigue acceleration.

*Compliance is checked by inspection and by the test of IEC 61373:2010, Clause 8, with three new samples, severities for each direction according to Table 8, test variable TV7 and frequency range from IEC 61373:2011, Figure 2. All electric contacts are series connected and monitored during the test. There shall be no electric discontinuance of more than 1  $\mu$ s.*

### 26.2.3 Accessories shall withstand shocks.

*Compliance is checked by inspection and by the test of IEC 61373:2010, Clause 10, with three new samples, severities for peak acceleration A and nominal duration D for each direction according to Table 8, test variable TV8. All electric contacts are series connected and monitored during the test. There shall be no electric discontinuance of more than 1  $\mu$ s.*

## 27 Electrical endurance

### 27.1 General requirements for accessories

Accessories shall have a minimum degree of electrical endurance.

The tests are made on accessories fitted with the cables or conduits for which they are designed, screwed glands and fixing screws of bodies and covers being tightened with a torque equal to the tests of IEC 60309-1:1999, IEC 60309-1:1999/AMD1:2005 and IEC 60309-1:1999/AMD2:2012, 24.5 or 25.1, as appropriate.

*Compliance is checked by inspection and by the tests of 27.2 and 27.3 with three new or used samples.*

### 27.2 Temperature burden for accessories

Accessories shall have an appropriate electrical endurance during temperature burden.

A temperature burden shall not have a negative effect on the electrical reliability of the equipment.

*Compliance is checked by inspection and by the following test procedure. Sixty cycles by the test of Annex A, afterwards the test of 27.3 and thereafter 60 cycles according the test of Annex A shall be performed. After this, the temperature rise by the test of Clause 19, the insulation resistance and the dielectric strength by the test of Clause 17 shall be checked.*



*Samples are considered to comply with the test if:*

- *An inspection, with normal or corrected to normal vision, and without additional magnification, shows no changes obviously impairing further use, such as cracks, deformations, and the like.*
- *The deviation of each individual recorded value of the temperature rise by the test of Annex A is maintained within  $T_{avg} \pm 15\%$ .*

### **27.3 Damp heat for accessories**

Accessories shall have appropriate cyclic damp heat endurance.

*Compliance is checked by inspection and by the test of IEC 60068-2-30 with Table 8 test variables TV4 and TV5.*

### **27.4 Contact resistance**

Accessories shall have an appropriate contact resistance.

*Compliance is checked by inspection and by the test of IEC 60512, test n° 2b with three new or used samples. The contact resistance is measured with the rated current. The test voltage is at least 1 V.*

*The tests are made on accessories fitted with the cables or conduits for which they are designed, screwed glands and fixing screws of bodies and covers being tightened with a torque equal to that of the tests of IEC 60309-1:1999, IEC 60309-1:1999/AMD1:2005 and IEC 60309-1:1999/AMD2:2012, 24.5 or 25.1, as appropriate.*

*Accessories are mounted as in normal use. Screwed caps or lids, if any, are tightened as in normal use. Accessories are mounted in a position as intended by the assembly. Tests are conducted with any doors, access panels, covers, etc., provided in the assembly both in the unmated, open, and closed positions. Accessories are placed in the most unfavourable position.*

*The measurement points shall be located at the conductors as close as possible to the termination. If this is not possible, the conductor resistance shall be recalculated.*

*After this, the temperature rise by the test of Clause 19, the insulation resistance and the dielectric strength by the test of Clause 17 should be checked.*

## **28 Climatic endurance for contacts**

### **28.1 General requirements for contacts**

Contacts shall have a minimum degree of climatic endurance.

*Compliance is checked by inspection and by the following test with three new or used samples.*

*The tests are made on accessories fitted with the cables or conduits for which they are designed, screwed glands and fixing screws of bodies and covers being tightened with a torque equal to the tests of IEC 60309-1:1999, IEC 60309-1:1999/AMD1:2005 and IEC 60309-1:1999/AMD2:2012, 24.5 or 25.1, as appropriate.*

*Accessories are mounted as in normal use. Screwed caps or lids, if any, are tightened as in normal use. Accessories are mounted in a position as intended in the assembly. Tests are conducted with any doors, access panels, covers, etc., provided by the assembly both in the*

*unmated, open, and closed positions. Accessories are placed in the most unfavourable position.*

### **28.2 Thermal change for contacts**

Contacts shall have an appropriate thermal change resistance.

*Compliance is checked by inspection of the contacts and by the test of IEC 60068-2-14, Test Nb, with 20 cycles, from  $-40\text{ °C}$  to  $+130\text{ °C}$  for 3 h,  $t_{\text{change}} \leq 2\text{ h}$  with three new or used samples.*

### **28.3 Dry heat for contacts**

Contacts shall have an appropriate dry heat resistance.

*Compliance is checked by inspection of the contacts and by the test of IEC 60068-2-2, for 120 h, at  $130\text{ °C}$  with three new or used samples.*

### **28.4 Corrosion resistance for contacts**

Contacts shall have an appropriate corrosion resistance.

*Compliance is checked by inspection and by the test of IEC 60068-2-60, method from Table 8, test variable TV9 with 1 cycle of 21 days with three new or used samples.*

### **28.5 Damp heat for contacts**

Contacts shall have an appropriate damp heat resistance.

*Compliance is checked by inspection and by the test of IEC 60068-2-30 with cycles from Table 8, test variable TV10a,  $T_U = 25\text{ °C}$ ,  $T = 55\text{ °C}$  and the test by IEC 60068-2-38 with cycles from Table 8, test variable TV10b,  $T_U = -10\text{ °C}$ ,  $T = 65\text{ °C}$  with three new or used samples*

*Afterwards the dielectric test by Clause 17 shall be performed.*

### **28.6 Functionality for contacts**

Contacts shall have an appropriate functionality.

*Compliance is checked by inspection and by the test of IEC 61373 with three new or used samples.*

*Compliance is checked by inspection and by the test of IEC 61373 as described in 26.2.2 and 26.2.3.*

### **28.7 Shocks for contacts**

Contacts shall withstand shocks.

*Compliance is checked by inspection and by the test of IEC 61373, severities according to Table 8, test variable TV8 with discontinuities of  $\leq 1\text{ }\mu\text{s}$  with three new or used samples.*

## 29 Climatic endurance for bodies

### 29.1 General requirements for bodies

Bodies shall have a minimum degree of climatic endurance.

*The tests are made on accessories fitted with the cables or conduits for which they are designed, screwed glands and fixing screws of bodies and covers being tightened with a torque equal to that of the tests of IEC 60309-1:1999, IEC 60309-1:1999/AMD1:2005 and IEC 60309-1:1999/AMD2:2012, 24.5 or 25.1, as appropriate.*

*Accessories are mounted as in normal use. Screwed caps or lids, if any, are tightened as in normal use. Accessories are mounted in a position as intended in the assembly. Tests are conducted with any doors, access panels, covers, etc., provided by the assembly both in the unmated, open, and closed positions. Accessories are placed in the most unfavourable position.*

### 29.2 Dry heat for bodies

Bodies shall have an appropriate dry heat resistance.

*Compliance is checked by inspection and by the test of IEC 60068-2-2 with duration from Table 8, test variable TV11, temperature from Table 8, test variable TV5, with three new or used samples. Afterwards the ageing test from Clause 13 shall be performed.*

### 29.3 Cold resistance for bodies

Bodies shall have an appropriate cold resistance.

*Compliance is checked by inspection and by the test of IEC 60068-2-1, duration from Table 8, test variable TV12, temperature from Table 8, test variable TV4, with three new or used samples.*

### 29.4 Cold temperatures for bodies

Bodies shall mate in cold temperatures.

The force to connect or separate the two parts of the accessory shall be less than in Table 8, test variable TV14 at the temperature from Table 8, test variable TV4. This can be achieved with the help of a means to facilitate the operation.

The movement of either of these accessories need not necessarily be a single linear movement. The insertion and withdrawal force shall be applied as required by each stage of the insertion and withdrawal movement. The manufacturer shall state the position and direction at which this (these) force(s) shall be applied.

*Compliance may be checked by a spring scale or the following test with three new or used samples:*

*The fixed accessory is mounted such that the mating accessory moves vertically downward into it during the first stage of insertion. A principal weight of 9,2 kg is suitably suspended from the matching accessory. A supplementary weight of 0,8 kg is allowed to fall from a height of 5 cm onto the principal weight. The moving accessory shall enter the fixed accessory to the position required to engage the contacts properly.*

*The operation is then repeated for any subsequent movements.*

*The test is repeated using a fixed weight of 2,0 kg and no supplementary weight. The moving accessory shall not become inserted in the fixed accessory to the extent specified by the manufacturer. These tests are carried out in reverse also to check the withdrawal force to determine that the contacts disengage properly.*

### **30 Salt stress endurance**

#### **30.1 General requirements for accessories**

Accessories shall have a minimum degree of salt stress endurance.

*The tests are made on accessories fitted with the cables or conduits for which they are designed, screwed glands and fixing screws of bodies and covers being tightened with a torque equal to the tests of IEC 60309-1:1999, IEC 60309-1:1999/AMD1:2005 and IEC 60309-1:1999/AMD2:2012, 24.5 or 25.1, as appropriate.*

*Accessories are mounted as intended in normal use. Screwed caps or lids, if any, are tightened as in normal use. Accessories are mounted in a position as intended by the system. Tests shall be conducted with any doors, access panels, covers, etc., provided by the system both in the unmated, open, and closed positions. Accessories are placed in the most unfavourable position.*

#### **30.2 Salt stress resistance**

Accessories shall have an appropriate salt stress resistance.

The accessories shall be exposed to a test according to IEC 60068-2-52, severity level according to Table 8, test variable TV15.

*Compliance is checked by inspection and by the test of Clause 26, IEC 60309-1:1999, IEC 60309-1:1999/AMD1:2005 and IEC 60309-1:1999/AMD2:2012, 19.2 and 19.3 with three new or used samples.*

### **31 Operation with misalignments**

#### **31.1 Misalignment at normal operation**

Accessories shall be so constructed that a misalignment does not affect the normal operation.

- A misalignment can occur between the two parts of the accessory during the mating process orthogonal to the mating direction in the longitudinal (Y direction) and vertical (Z direction) axis as shown in Figure 2.
- Angular to the mating direction in the vertical ( $\alpha$ -angle) and longitudinal ( $\beta$ -angle) axis as shown in Figure 3 and Figure 4.

*Compliance is checked by inspection and by the following test with three new or used samples. Accessories are mounted as intended in normal use. The test apparatus shall be able to perform a complete mating process with a misalignment in Y and Z direction and  $\alpha$ - and  $\beta$ -angle.*

*The misalignment is changed in the unmated condition. All combinations of misalignments are tested in the sequence as stated in Table 6 with the dimensions as stated in Table 5. All unnumbered misalignments are tested after the numbered misalignments in any order. At least Table 8, test variable TV16 multiplied by 45 cycles of this test are performed with an even contingent of misalignments. The speed of insertion and withdrawal is 0,8 m/s  $\pm$  0,1 m/s. The test apparatus shall move the accessory type A in the  $\alpha$ - and  $\beta$ -angle and move the accessory type B into the Y and Z direction. The distance between the centre of rotation and the reference plane is according to Table 8, test variable TV17.*

*There shall be no cable terminated to the accessories. After performing the misalignment tests, a visual examination according to 4.4 is performed. There shall be no damage.*

*After the test, the accessories shall comply with the insulation resistance test and dielectric test of Clause 17.*

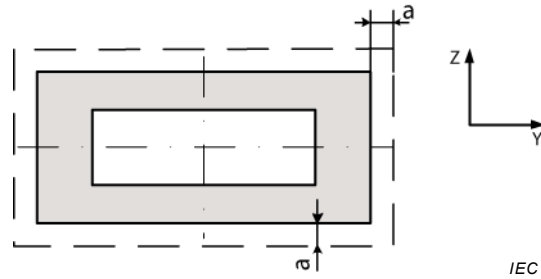

**Figure 2 – Orthogonal misalignment – front view**

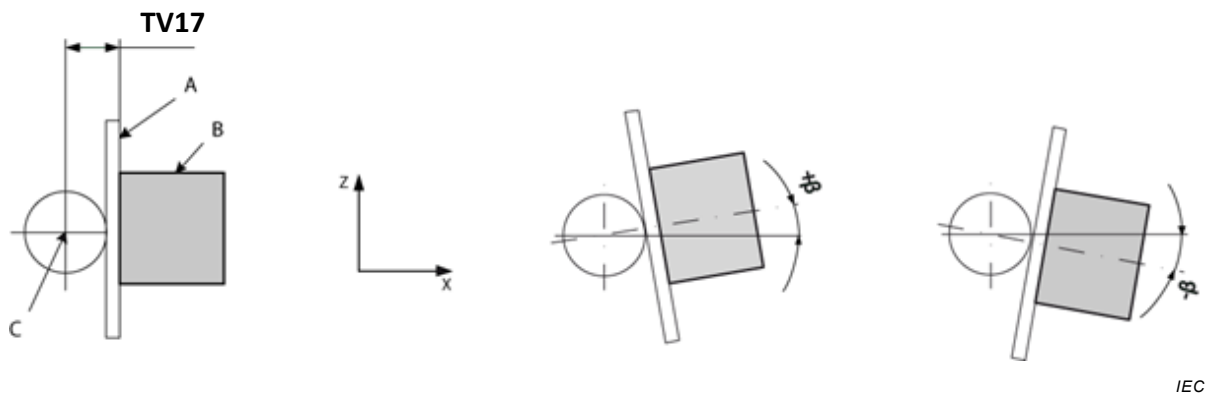

**Key**

- A datum plane/mounting face of sample
- B test sample
- C centre of rotation

**Figure 3 – Angular misalignment – side view**

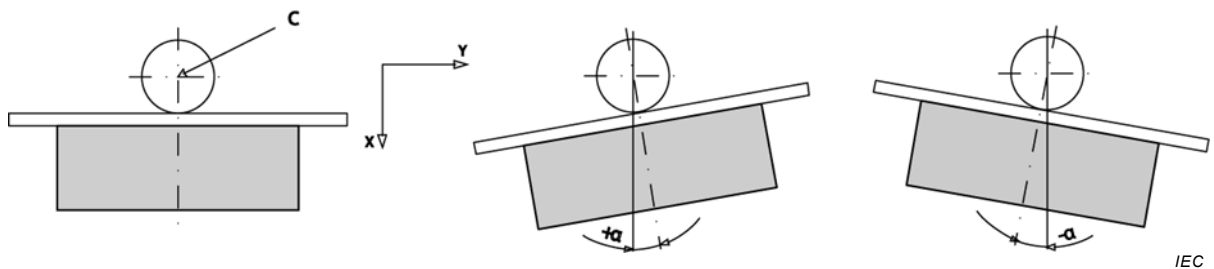

**Key**

- C centre of rotation

**Figure 4 – Angular misalignment – top view**

**Table 5 – Dimensions of misalignments**

Direction	Positive direction		Negative direction	
	Value from Table 8	Indication from Table 6	Value from Table 8	Indication from Table 6
Y	TV18	+y	-TV18	-y
Z	TV19	+z	-TV19	-z
$\alpha$	TV20	+ $\alpha$	-TV20	- $\alpha$
$\beta$	TV21	+ $\beta$	-TV21	- $\beta$

**Table 6 – Combinations of misalignments**

Sequence	Number	Y	Z	$\alpha$	$\beta$
	0	0	0	0	0
	1	0	0	0	$+\beta$
	2	0	0	0	$-\beta$
	3	0	0	$+\alpha$	0
	4	0	0	$-\alpha$	0
	5	0	$+z$	0	0
	6	0	$+z$	0	$+\beta$
	7	0	$+z$	0	$-\beta$
	8	0	$+z$	$+\alpha$	0
	9	0	$+z$	$-\alpha$	0
	10	0	$-z$	0	0
	11	0	$-z$	0	$+\beta$
	12	0	$-z$	0	$-\beta$
	13	0	$-z$	$+\alpha$	0
	14	0	$-z$	$-\alpha$	0
	15	$+y$	0	0	0
	16	$+y$	0	0	$+\beta$
	17	$+y$	0	0	$-\beta$
	18	$+y$	0	$+\alpha$	0
	19	$+y$	0	$-\alpha$	0
	20	$+y$	$+z$	0	0
3	21	$+y$	$+z$	0	$+\beta$
	22	$+y$	$+z$	0	$-\beta$
1	23	$+y$	$+z$	$+\alpha$	0
	24	$+y$	$+z$	$-\alpha$	0
	25	$+y$	$-z$	0	0
7	26	$+y$	$-z$	0	$+\beta$
	27	$+y$	$-z$	0	$-\beta$
	28	$+y$	$-z$	$+\alpha$	0
5	29	$+y$	$-z$	$-\alpha$	0
	30	$-y$	0	0	0
	31	$-y$	0	0	$+\beta$
	32	$-y$	0	0	$-\beta$
	33	$-y$	0	$+\alpha$	0
	34	$-y$	0	$-\alpha$	0
	35	$-y$	$+z$	0	0
8	36	$-y$	$+z$	0	$+\beta$
	37	$-y$	$+z$	0	$-\beta$
6	38	$-y$	$+z$	$+\alpha$	0
	39	$-y$	$+z$	$-\alpha$	0
	40	$-y$	$-z$	0	0
	41	$-y$	$-z$	0	$+\beta$
4	42	$-y$	$-z$	0	$-\beta$
	43	$-y$	$-z$	$+\alpha$	0
2	44	$-y$	$-z$	$-\alpha$	0

### 31.2 Misalignment after unmating

Accessories shall be so constructed that a misalignment of the mating faces does not remain after unmating.

*Compliance is checked by inspection and by the following test with three new or used samples.*

*This test is only applicable for the accessories of Type A, case 5 and Type B, case 4.*

*In all other cases, the superordinate system shall take measures in order to guarantee the proper mating and unmating process.*

*Every part of the accessory designed for self-adjustment shall be in the nominal position as indicated in the relevant standard sheet for the unmated condition. This ensures compliance with the lock-in-range during the mating process.*

*Compliance is checked by inspection and by the following test. The power contacts of the moveable parts of the accessory is displaced at one of the positions from Table 5 and loosened. The power contacts shall reach the normal position as indicated in the relevant standard sheet for the unmated condition within 1 s. This test is performed into the -y, +y, -z and +z direction of the force for all combinations from Table 6.*

*Afterwards the test in Subclause 27.4 shall be performed.*

### 31.3 Misalignment by terminated wires

Accessories shall be so constructed that a misalignment does not occur with terminated wires.

Every part of the accessory designed for self-adjustment shall be in the nominal position as indicated in the relevant standard sheet for the unmated condition while a cable is terminated at the power contacts. This ensures the compliance with the lock-in-range during the mating process.

*Compliance is checked by inspection and by the following test with three new or used samples. A force of 100 N is applied to every power contact at the termination. All parts of the accessory shall remain at the normal position as indicated in the relevant standard sheet for the unmated condition. This test is performed into the -y, +y, -z and +z direction of the force for all combinations from Table 6.*

### 31.4 Mating process effected by misalignment

Accessories shall be so constructed that a misalignment does not obstruct the mating process.

This test is only applicable for the accessories Type A, Case 6 and Type B, Case 3.

In all other cases, the superordinate system shall take measures in order to guarantee the proper mating and unmating process.

*Compliance is checked by inspection and by the following test with three new or used samples. Accessories are mounted as intended in normal use. The test apparatus shall be able to perform a complete mating process with a misalignment of the movable part of the accessory in the Y and Z direction and  $\alpha$ - and  $\beta$ -angle.*

*The misalignment is changed in the unmated condition. All combinations of misalignments are tested in the sequence as stated in Table 6 with the dimensions as stated in Table 5. All unnumbered misalignments are tested after the numbered misalignments in any order. At*



least TV16 from Table 8 multiplied by 45 cycles of this test are performed with an even contingent of misalignments. The speed of insertion and withdrawal is 0,8 m/s  $\pm$ 0,1 m/s. The test apparatus shall move the movable part of the accessory in the  $\alpha$  and  $\beta$  angle and into the Y and Z direction.

Afterwards, the test in 26.2 shall be performed.

### 32 Environmental conditions

The accessories may be intended for different applications with typical environmental conditions. The following fields of applications are classified in this standard according to Table 7.

Manufactures shall classify their product according to one or more of these environmental performance classes. All tests shall be performed according to the severities described in Table 8 for the chosen environmental performance class. When the removable energy storage unit is not connected to the vehicle, the requirements from Class O are applicable to the accessory.

Accessories foreseen for other application areas shall apply the relevant environmental requirements and at least the conditions from environmental performance class C.

**Table 7 – Environmental performance classes**

Abbreviation	Name	Typical application
R	Road vehicles	Road vehicles <sup>a,b</sup>
T	Industrial trucks	Forklifts and other industrial trucks <sup>a</sup>
C	Indoor controlled environment	Removable energy storage unit located inside a building with controlled environmental conditions
O	Outdoor protected environment	Removable energy storage unit located on weather-protected, not temperature-controlled, locations typically outdoors but enclosed or covered
I	Industrial environment	Removable energy storage unit located on automation islands with machines and tools derived from the MICE (M3I3C3E3) classification according ISO/IEC TR 29106
X	Manufacturers declaration	Application and severity according to manufacturer's declaration
<sup>a</sup> Requirements according to the relevant ISO standard. For further information, see Annex B. <sup>b</sup> Definition of road vehicles according to the scope of IEC TC 69.		

**Table 8 – Severities for environmental performance classes**

Test	Clause/ subclause	Test variable	Minimum severity			
			C	O	I	X
IP-rating	16	TV1	21	44	65 and 67	21 <sup>b</sup>
Mating cycles on load <sup>c</sup>		TV2a				
Mating cycles off load <sup>c</sup>		TV2b				
Impact energy at TV4	20	TV3	IK09	IK09 10 J	IK09 10 J	IK09 <sup>b</sup>
Minimum operating temperature	20	TV4	0 °C	–20 °C	–20 °C	0 °C <sup>b</sup>
Maximum operating temperature	27.3	TV5	40 °C	55 °C	60 °C	40 °C <sup>b</sup>
Vibration	26.2.2	TV7	5 ms <sup>-2</sup>	5 ms <sup>-2</sup>	50 ms <sup>-2</sup>	5 ms <sup>-2</sup> <sup>b</sup>
Shock	26.2.3	TV8	40 ms <sup>-2</sup> , 30 ms	40 ms <sup>-2</sup> , 30 ms	250 ms <sup>-2</sup> , 30 ms	40 ms <sup>-2</sup> , 30 ms <sup>b</sup>
Mixed gas	28.4	TV9	3	4	4	3 <sup>b</sup>
Damp heat without freezing	28.5	TV10a	0	1	5	0 <sup>b</sup>
Damp heat with freezing	28.5	TV10b	0	1	0	0 <sup>b</sup>
Dry heat duration	29.2	TV11	0 h	24 h	48 h	0 h <sup>b</sup>
Cold duration	29.3	TV12	0 h	12 h	24 h	≥0 h <sup>b</sup>
Mating force	29.4	TV14	a			b
Salt stress severity level	30.2	TV15	0	2	1	≥0 <sup>b</sup>
Misalignment sequences	31.1	TV16	Min. 1 <sup>a</sup>			
Distance to the centre of rotation	31.1	TV17	Min. 1 mm <sup>a</sup>			
Misalignment in Y-direction	31.1	TV18	Min. 1 mm <sup>a</sup>			
Misalignment in Z-direction	31.1	TV19	Min. 1 mm <sup>a</sup>			
Misalignment in α-direction	31.1	TV20	Min. 1° <sup>a</sup>			
Misalignment in β-direction	31.1	TV21	Min. 1° <sup>a</sup>			
<sup>a</sup> More stringent severities or limitations to be defined in the relevant standard sheet for the accessory.						
<sup>b</sup> More stringent severities or limitations to be defined by the manufacturer's declaration.						
<sup>c</sup> Reserved for further study.						

## Annex A (normative)

### Test cycle electric endurance

The following remarks apply to Figure A.1.

The test current is the rated current  $I_n$ .

$T_{\min}$  is equal to Table 8, test variable TV4.

$T_{\max}$  is equal to Table 8, test variable TV5.

$T_1$  is the time needed to reach thermal stabilization, but not less than 0,5 h.

The contact temperature is measured by sensors at the contact in the climatic cabinet.

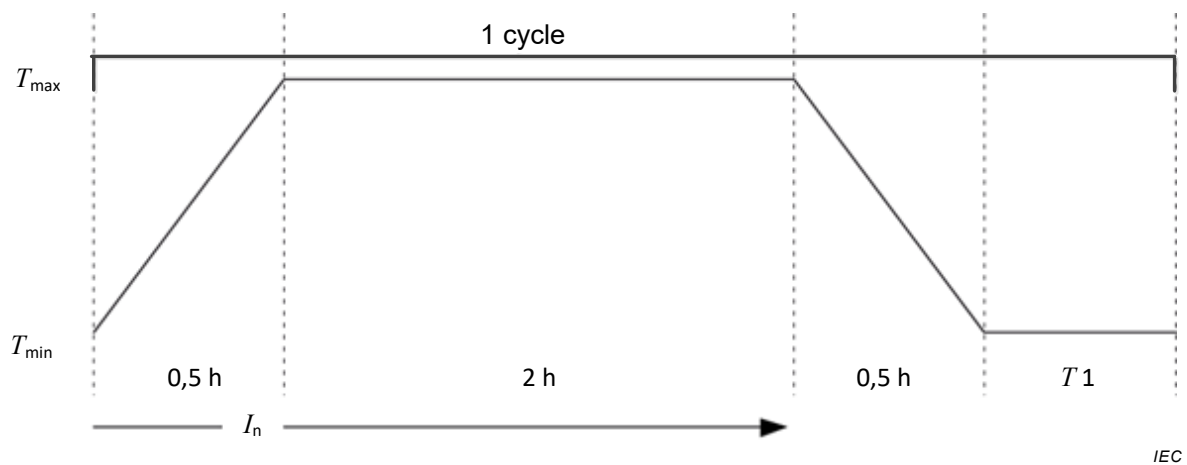

Figure A.1 – Test cycle for electric endurance

## Annex B (informative)

### Environmental performance classes for vehicles

If there is no other relevant standard, then Table B.1 gives the severities for the vehicles in Table 7 during all operating conditions.

**Table B.1 – Severities for environmental performance classes for vehicles**

Test	Clause/ subclause	Test variable	Minimum severities
			R and T
IP-rating	16	TV1	65
Mating cycles on load <sup>b</sup>		TV2a	
Mating cycles off load <sup>b</sup>		TV2b	
Impact energy	20	TV3	1 J
Minimum operating temperature	20	TV4	–20 °C
Maximum operating temperature	27.3	TV5	60 °C
Vibration	26.2.2	TV7	ISO 16750-3:2012, 4.1.2.4
Shock	26.2.3	TV8	300 ms <sup>-2</sup>
Mixed gas	28.4	TV9	4
Damp heat without freezing	28.5	TV10a	5
Damp heat with freezing	28.5	TV10b	5
Dry heat duration	29.2	TV11	48
Cold duration	29.3	TV12	24
Mating force	29.4	TV14	<sup>a</sup>
Salt stress severity level	30.2	TV15	4
Misalignment sequences	31.1	TV16	Min. 1 <sup>a</sup>
Distance to the centre of rotation	31.1	TV17	Min. 1 mm <sup>a</sup>
Misalignment in Y-direction	31.1	TV18	Min. 1 mm <sup>a</sup>
Misalignment in Z-direction	31.1	TV19	Min. 1 mm <sup>a</sup>
Misalignment in $\alpha$ -direction	31.1	TV20	Min. 1° <sup>a</sup>
Misalignment in $\beta$ -direction	31.1	TV21	Min. 1° <sup>a</sup>
<sup>a</sup> More stringent severities or limitations to be defined in the relevant standard for the accessory.			
<sup>b</sup> Reserved for further study.			

## **Annex C** (informative)

### **Examples for accessories on the market**

#### **C.1 General**

The accessory examples in this annex show possible solutions for several applications. Requirements and tests mentioned in this standard apply also to designs in this annex.

#### **C.2 Accessory example 1**

Table C.1 shows parameters and Figure C.1 and Figure C.2 show dimensions in mm. Figure C.3 shows the layout and essential dimensions without tolerances for the accessory example 1.

**Table C.1 – Parameters for accessory example 1**

Parameter (see Clause 6)	Value
Purpose	Stationary energy storage system for stabilizing the grid, storing renewable energy or providing electric energy in off-grid locations. Accessory with dedicated contacts for power, signaling and data communication.
Degree of protection (mated condition)	IP21
Earthing facilities	Yes
Method of connecting the cable	Screw
Interlocking facilities	None
Type of terminals	Screw
Type of conductors	Single wire, solid and stranded
Accessibility to live parts	IPXXB
Locking facilities	None
Presence of shutter(s)	Accessory without shutters
Environmental performance class	C
Case of use	6
Maximum mating force	60 N
Type	A and B
Mating cycles according to Clause 18	100

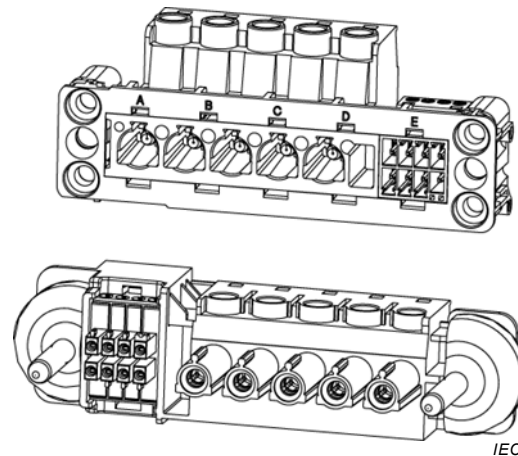

**Figure C.1 – Layout of accessory example 1**

Dimensions in millimetres

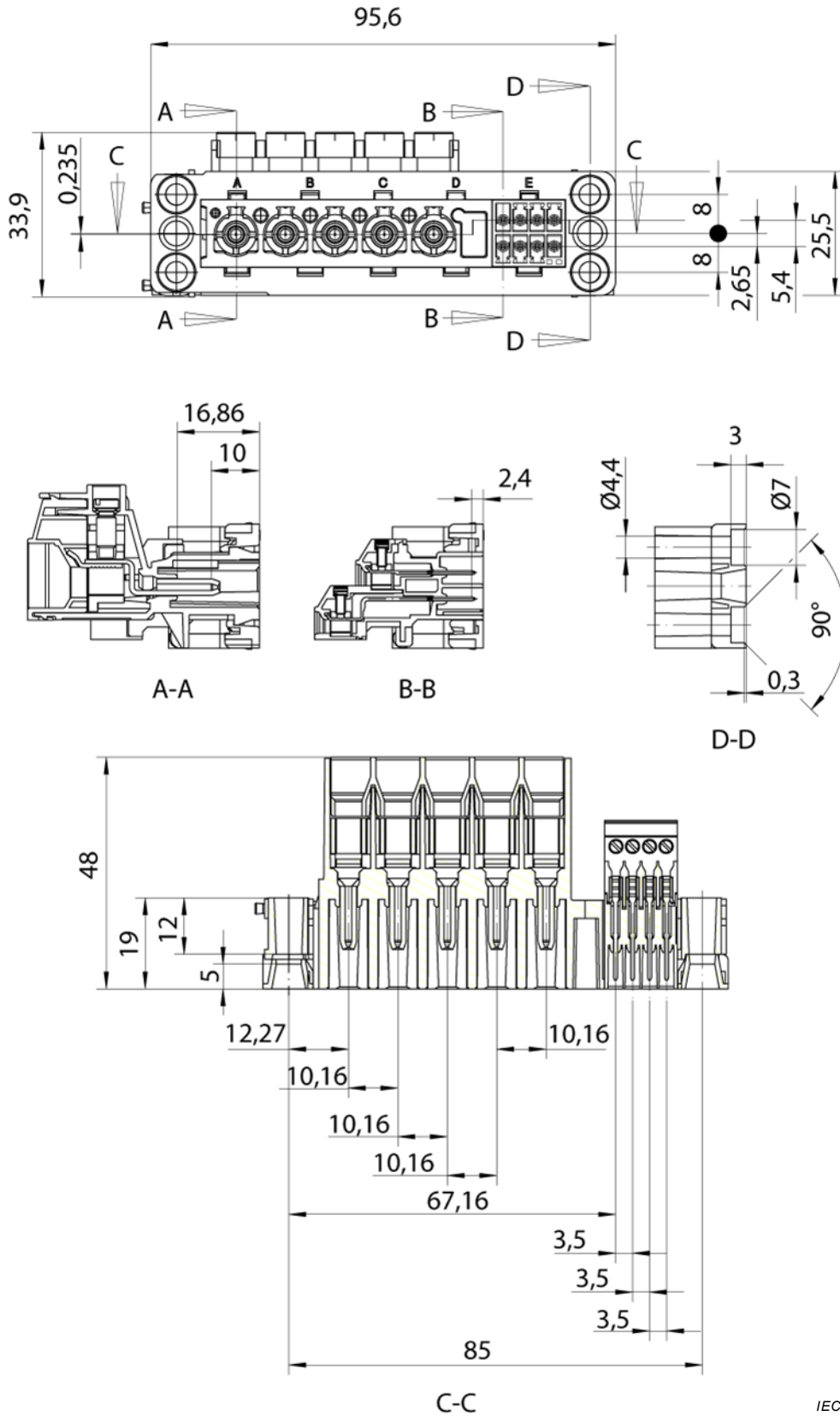
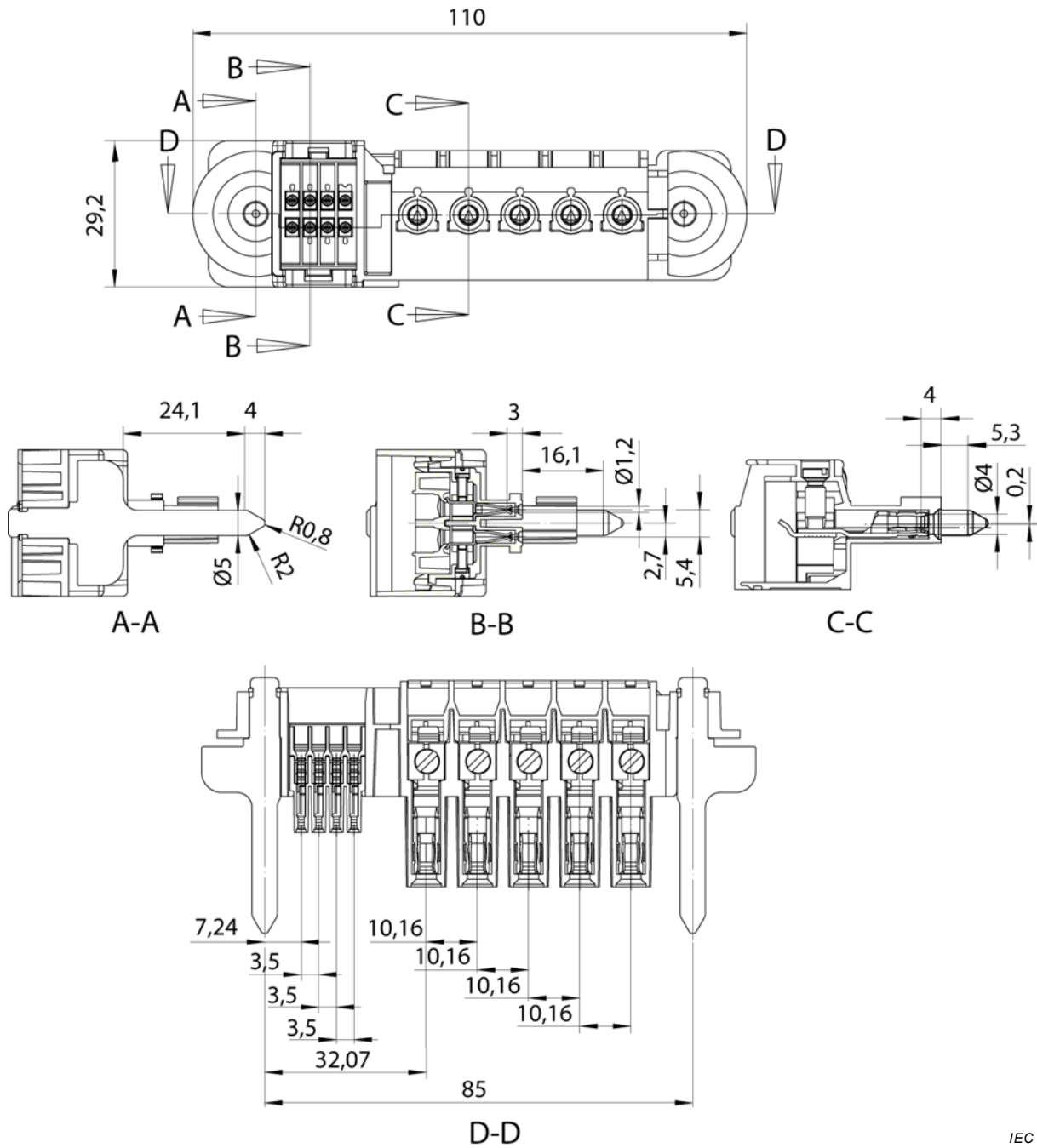

Figure C.2 – Accessory example 1 Type A

IEC

Dimensions in millimetres



IEC

Figure C.3 – Accessory example 1 Type B

### C.3 Accessory example 2

Table C.2 shows parameters and Figure C.4 and Figure C.5 show dimensions in mm.

Figure C.6 shows the layout and essential dimensions without tolerances for the accessory example 2.



**Table C.2 – Parameters for accessory example 2**

Parameter (see Clause 6)	Value
Purpose	Stationary energy storage system for stabilizing the grid, storing renewable energy or providing electric energy in off-grid locations. Accessory with dedicated contacts for power only.
Degree of protection (mated condition)	IP21
Earthing facilities	Yes
Method of connecting the cable	Screw
Interlocking facilities	None
Type of terminals	Screw
Type of conductors	Single wire, solid and stranded
Accessibility to live parts	IPXXB
Locking facilities	None
Presence of shutter(s)	Accessory without shutters
Environmental performance class	C
Case of use	6
Maximum mating force	35 N
Type	A and B
Mating cycles according to Clause 18	100

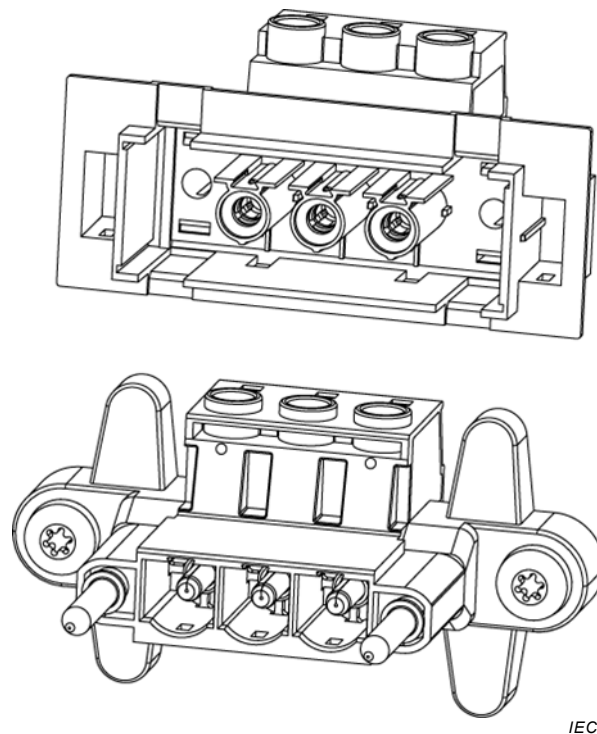

IEC

**Figure C.4 – Layout of accessory example 2**

*Dimensions in millimetres*

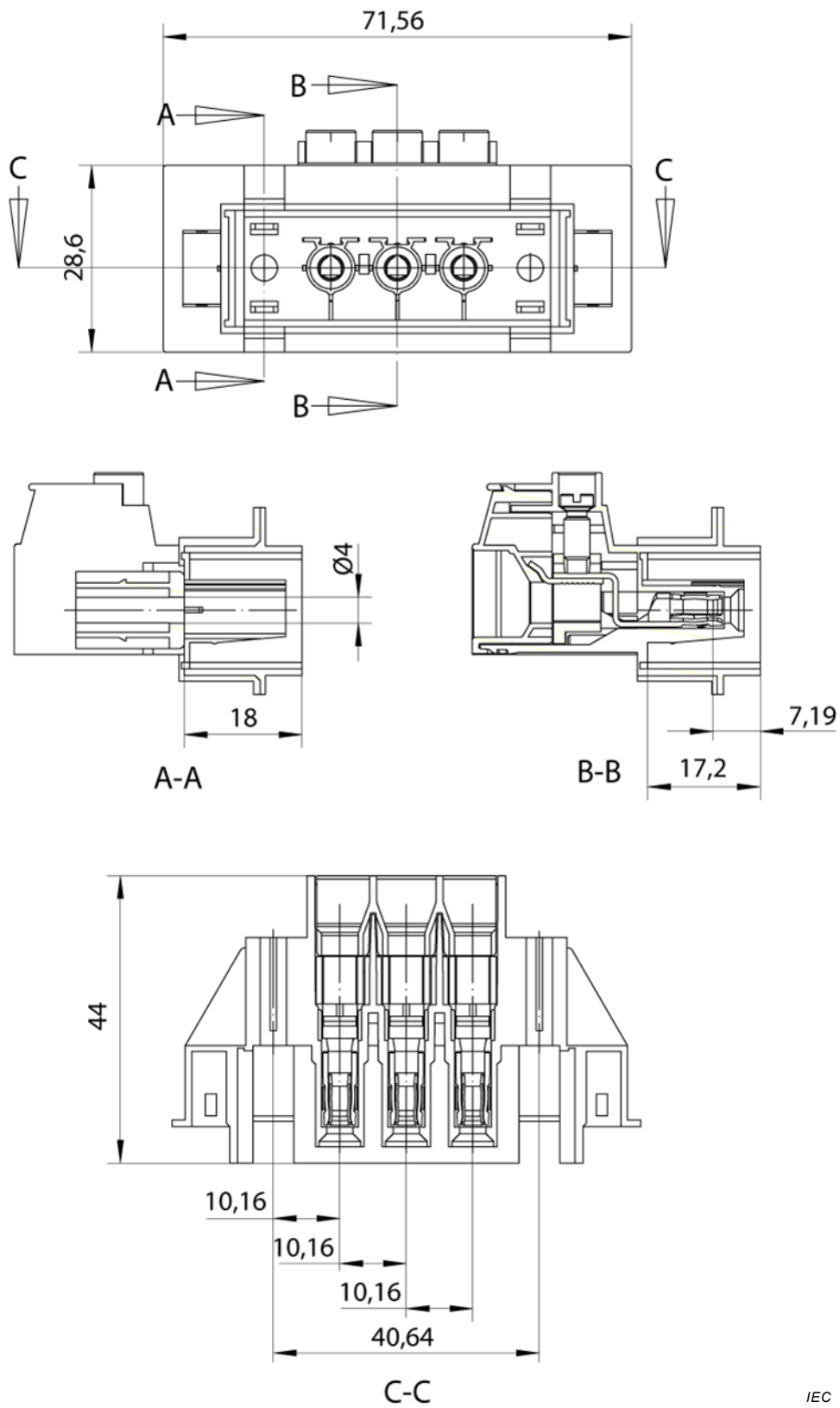

IEC

**Figure C.5 – Accessory example 2 Type A**

*Dimensions in millimetres*

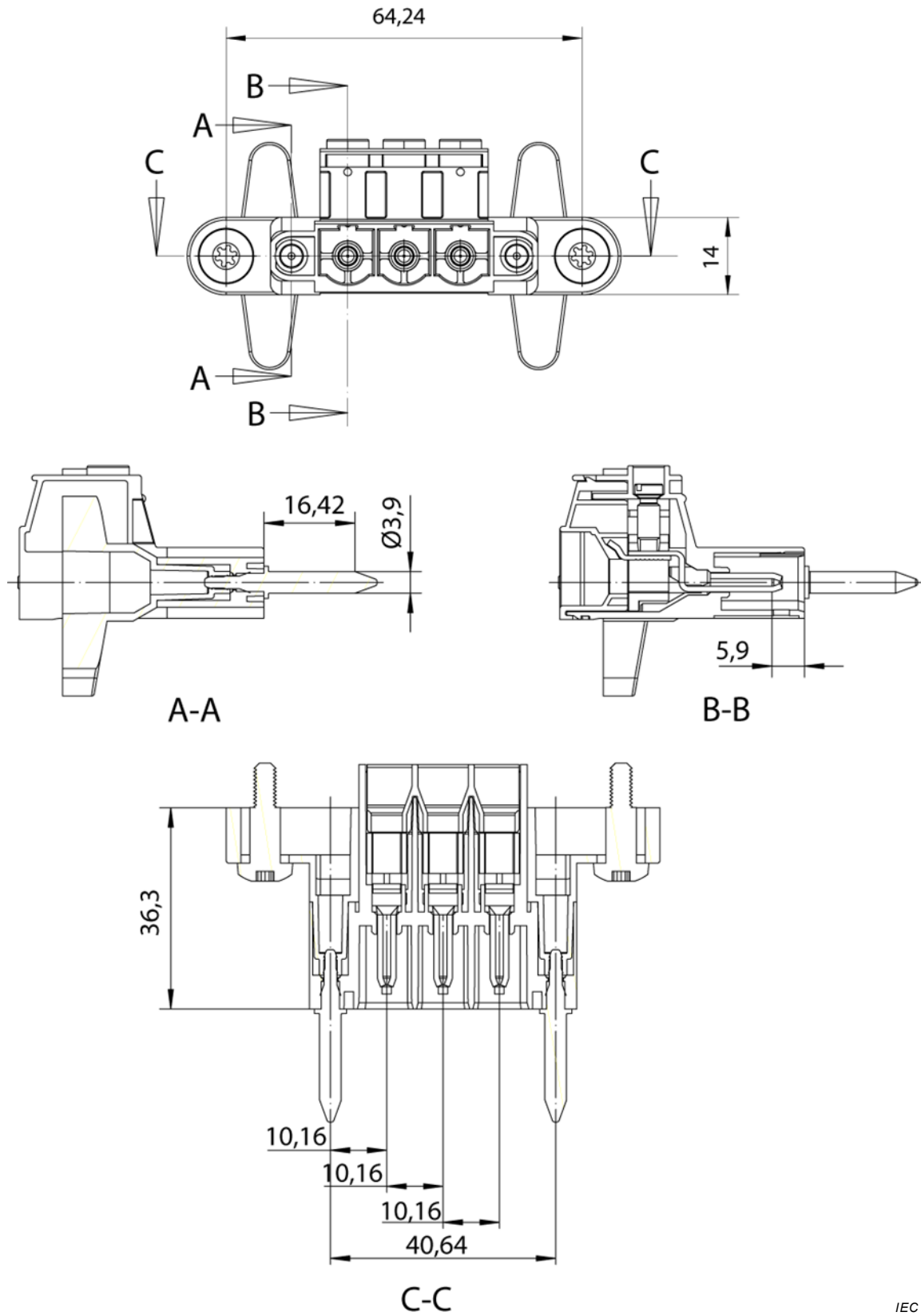

**Figure C.6 – Accessory example 2 Type B**

### C.4 Accessory example 3

Table C.3 shows parameters and Figure C.7 shows dimensions in mm. Figure C.8 shows essential dimensions without tolerances for the accessory example 3.

**Table C.3 – Parameters for accessory example 3**

Parameter (see Clause 6)	Value
Purpose	Energy storage system for EVs. Accessory with dedicated contacts for power, signaling and data communication.
Degree of protection (mated condition)	IP54
Earthing facilities	Yes
Method of connecting the cable	Screw
Interlocking facilities	None
Type of terminals	Screw
Type of conductors	Single wire, solid and stranded
Accessibility to live parts	Less than IPXXB
Locking facilities	None
Presence of shutter(s)	Accessory without shutters
Environmental performance class	R, T and O
Case of use	5
Maximum mating force	400 N
Type	A and B
Mating cycles according to Clause 18	5 000

*Dimensions in millimetres*

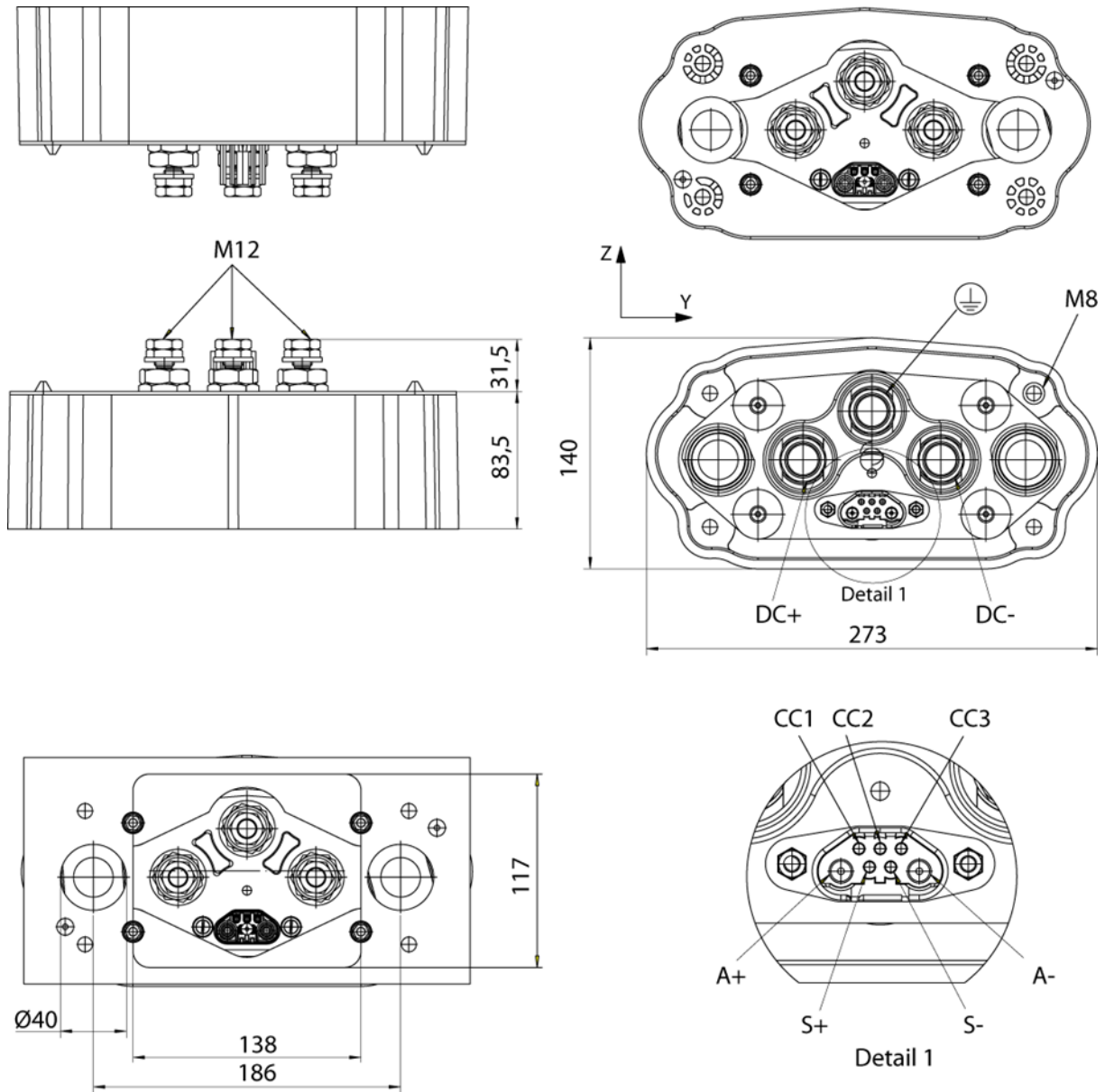

IEC

**Figure C.7 – Accessory example 3 Type A**

Dimensions in millimetres

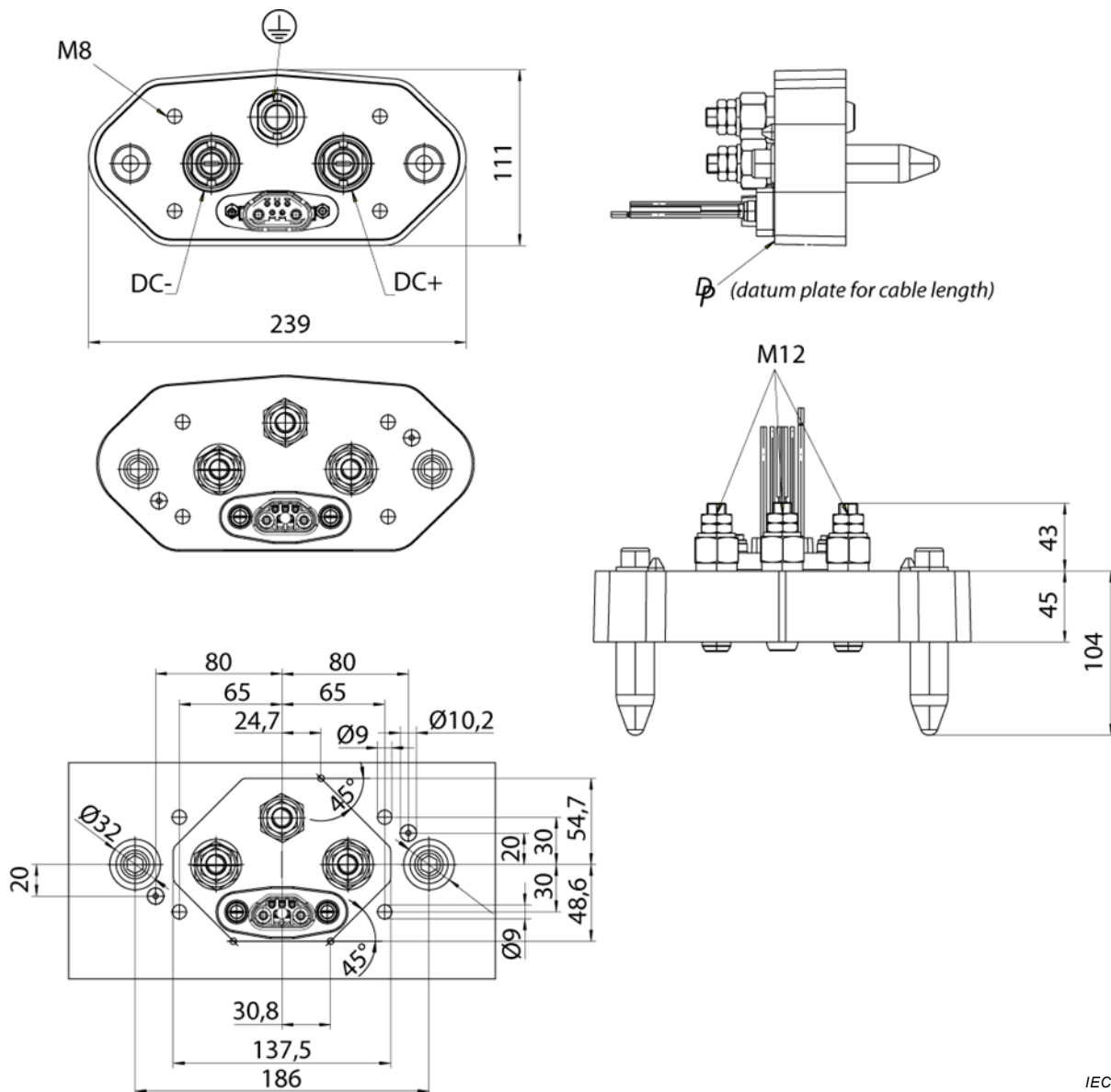

IEC

Figure C.8 – Accessory example 3 Type B

### C.5 Accessory example 4

Table C.4 shows parameters and Figure C.9 and Figure C.10 show essential dimensions without tolerances for the accessory example 4.

**Table C.4 – Parameters for accessory example 4**

Parameter (see Clause 6)	Value
Purpose	Applicable for removable EV battery swap packs
Degree of protection (mated condition)	IP44
Earthing facilities	Earthing pin
Method of connecting the cable	rewirable accessories
Interlocking facilities	No locking
Type of terminals	Compression type terminal
Type of conductors	Single wire, solid and stranded
Accessibility to live parts	Less than IPXXB
Locking facilities	None
Presence of shutter(s)	Accessory without shutters
Environmental performance class	R and O
Case of use	4
Maximum mating force	140 N
Type	A and B
Mating cycles according to Clause 18	5 000

*Dimensions in millimetres*

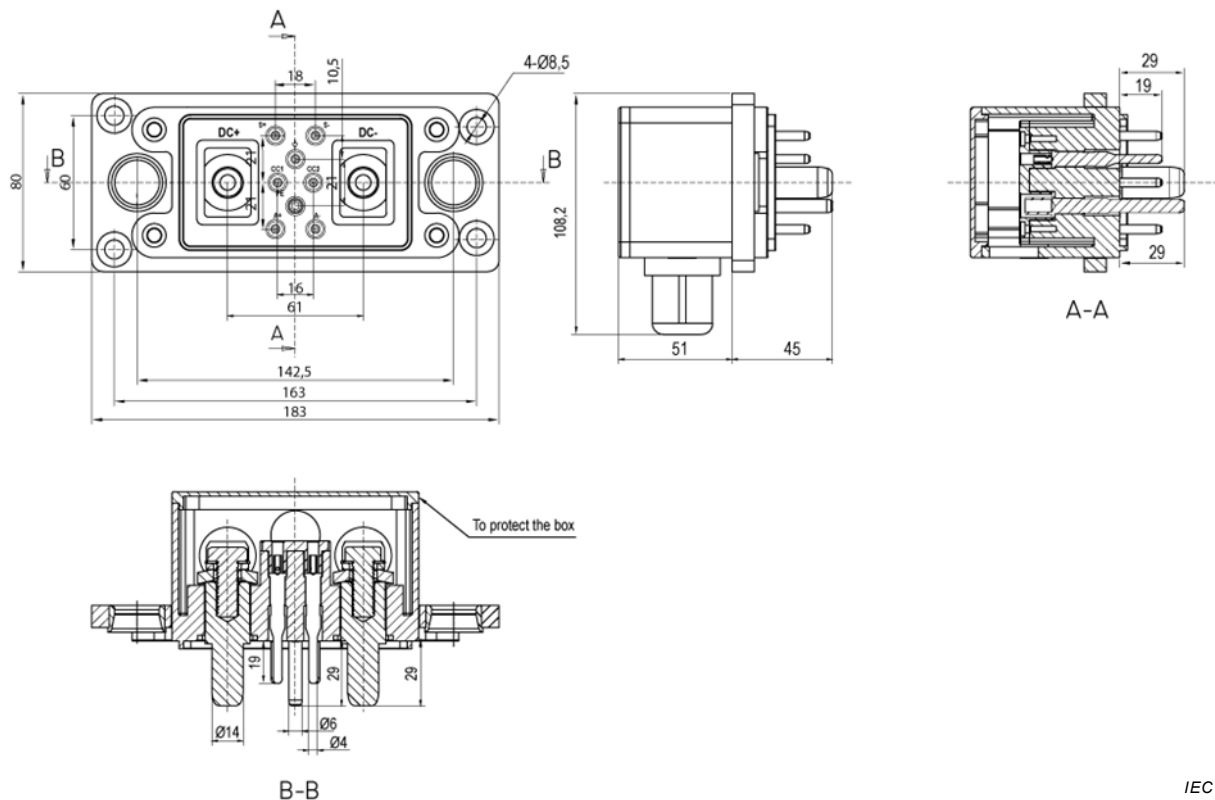

IEC

**Figure C.9 – Drawings for accessory example 4 Type A**

Dimensions in millimetres

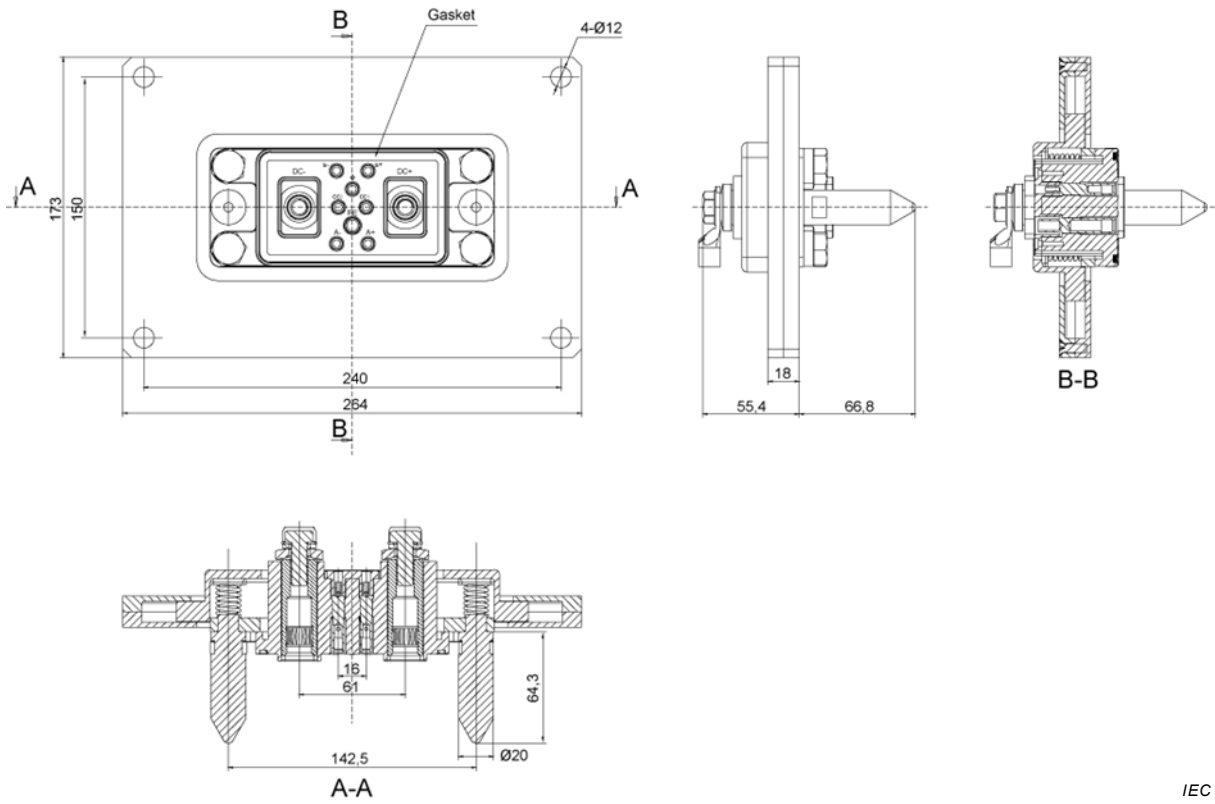

IEC

Figure C.10 – Drawings for accessory example 4 Type B

### C.6 Accessory example 5

Table C.5 shows parameters and Figure C.11 and Figure C.12 show essential dimensions without tolerances for the accessory example 5.



**Table C.5 – Parameters for accessory example 5**

Parameter (see Clause 6)	Value
Purpose	Docking connectors
Degree of protection (mated condition)	IP67
Earthing facilities	Accessories without earthing contact
Method of connecting the cable	Rewirable accessories
Interlocking facilities	Accessories without interlock
Type of terminals	Compression type terminal
Type of conductors	H62 brass
Accessibility to live parts	IPXXB
Locking facilities	Lockable accessories
Presence of shutter(s)	Accessory without shutters
Environmental performance class	R, T and O
Case of use	5
Maximum mating force	300 N
Type	A and B
Mating cycles according to Clause 18	5 000

*Dimensions in millimetres*

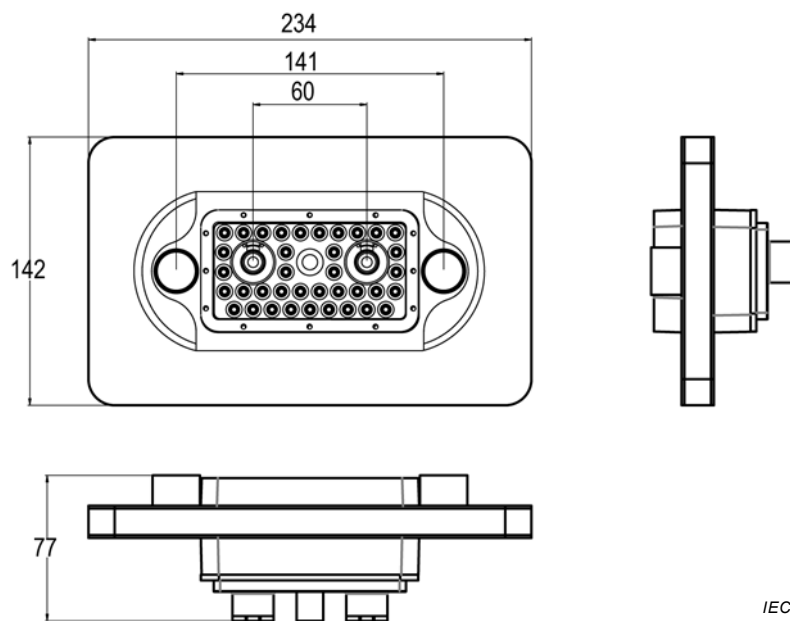

**Figure C.11 – Drawings for accessory example 5 Type A**

Dimensions in millimetres

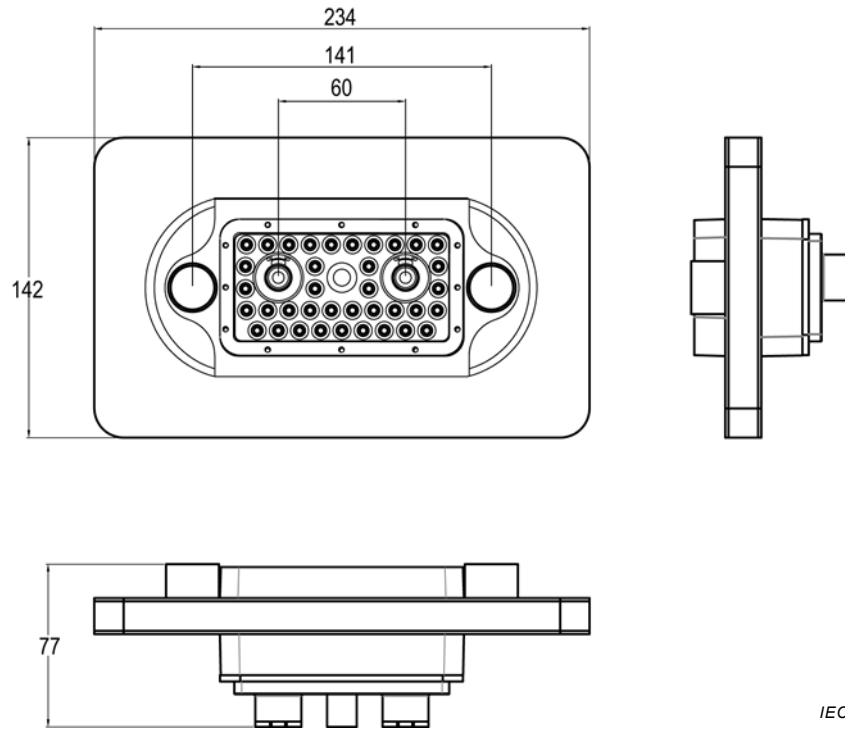

IEC

Figure C.12 – Drawings for accessory example 5 Type B

### C.7 Accessory example 6

Table C.6 shows parameters and Figure C.13 and Figure C. 14 show essential dimensions for the accessory example 6.

Table C.6 – Parameters for accessory example 6

Parameter (see Clause 6)	Value
Purpose	Provide electrical connection between removable energy storage unit and electrical vehicles
Degree of protection (mated condition)	IP67
Earthing facilities	Grounding mounting screws
Method of connecting the cable	Welding to pin
Interlocking facilities	Mechanical lock
Type of terminals	Plate with silver
Type of conductors	Copper
Accessibility to live parts	IPXXB
Locking facilities	By the spring
Presence of shutter(s)	Accessory without shutters
Environmental performance class	R, T and O
Case of use	5
Maximum mating force	200 N (mating only)
Type	A and B
Mating cycles according to Clause 18	5 000

Dimensions in millimetres

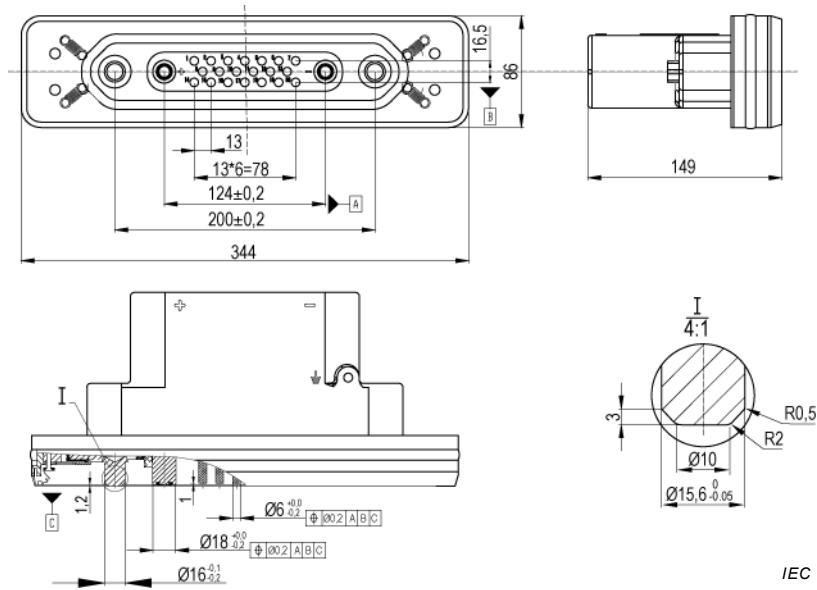

IEC

Figure C.13 – Drawings for accessory example 6 Type A

Dimensions in millimetres

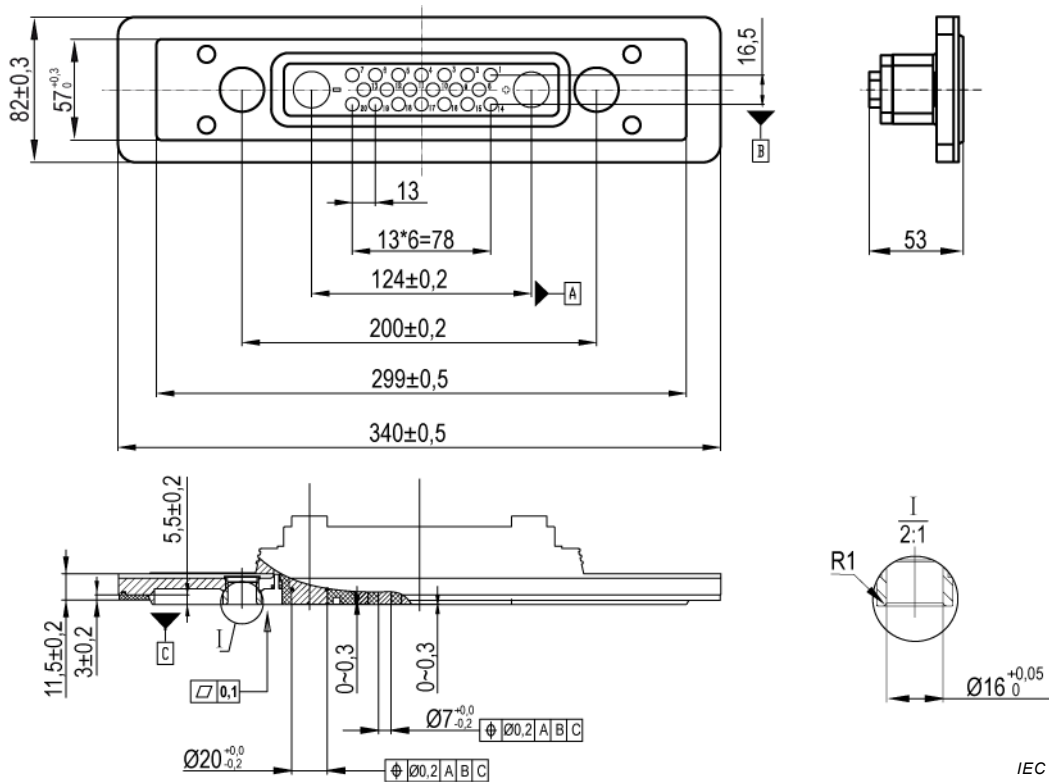

IEC

Figure C. 14 – Drawings for accessory example 6 Type B

## Bibliography

IEC 60050-195, *International Electrotechnical Vocabulary – Part 195: Earthing and protection against electric shock*

IEC 60884-1:2002, *Plugs and socket-outlets for household and similar purposes – Part 1: General requirements*

IEC 60884-1:2002/AMD1:2006

IEC 60884-1:2002/AMD2:2013

IEC 62133, *Secondary cells and batteries containing alkaline or other non-acid electrolytes – Safety requirements for portable sealed secondary cells, and for batteries made from them, for use in portable applications*

ISO 61750-3:2012, *Road vehicles – Environmental conditions and testing for electrical and electronic equipment – Part 3: Mechanical loads*

UN Recommendations on the Transport of Dangerous Goods. Manual of Tests and Criteria (Fourth revised ed.), New York and Geneva: United Nations, 2002, ISBN 92-1-139087-7, ST/SG/AC.10/11/Rev.4

---



# British Standards Institution (BSI)

BSI is the national body responsible for preparing British Standards and other standards-related publications, information and services.

BSI is incorporated by Royal Charter. British Standards and other standardization products are published by BSI Standards Limited.

## About us

We bring together business, industry, government, consumers, innovators and others to shape their combined experience and expertise into standards-based solutions.

The knowledge embodied in our standards has been carefully assembled in a dependable format and refined through our open consultation process. Organizations of all sizes and across all sectors choose standards to help them achieve their goals.

## Information on standards

We can provide you with the knowledge that your organization needs to succeed. Find out more about British Standards by visiting our website at [bsigroup.com/standards](http://bsigroup.com/standards) or contacting our Customer Services team or Knowledge Centre.

## Buying standards

You can buy and download PDF versions of BSI publications, including British and adopted European and international standards, through our website at [bsigroup.com/shop](http://bsigroup.com/shop), where hard copies can also be purchased.

If you need international and foreign standards from other Standards Development Organizations, hard copies can be ordered from our Customer Services team.

## Copyright in BSI publications

All the content in BSI publications, including British Standards, is the property of and copyrighted by BSI or some person or entity that owns copyright in the information used (such as the international standardization bodies) and has formally licensed such information to BSI for commercial publication and use.

Save for the provisions below, you may not transfer, share or disseminate any portion of the standard to any other person. You may not adapt, distribute, commercially exploit, or publicly display the standard or any portion thereof in any manner whatsoever without BSI's prior written consent.

## Storing and using standards

Standards purchased in soft copy format:

- A British Standard purchased in soft copy format is licensed to a sole named user for personal or internal company use only.
- The standard may be stored on more than 1 device provided that it is accessible by the sole named user only and that only 1 copy is accessed at any one time.
- A single paper copy may be printed for personal or internal company use only.

Standards purchased in hard copy format:

- A British Standard purchased in hard copy format is for personal or internal company use only.
- It may not be further reproduced – in any format – to create an additional copy. This includes scanning of the document.

If you need more than 1 copy of the document, or if you wish to share the document on an internal network, you can save money by choosing a subscription product (see 'Subscriptions').

## Reproducing extracts

For permission to reproduce content from BSI publications contact the BSI Copyright & Licensing team.

## Subscriptions

Our range of subscription services are designed to make using standards easier for you. For further information on our subscription products go to [bsigroup.com/subscriptions](http://bsigroup.com/subscriptions).

With **British Standards Online (BSOL)** you'll have instant access to over 55,000 British and adopted European and international standards from your desktop. It's available 24/7 and is refreshed daily so you'll always be up to date.

You can keep in touch with standards developments and receive substantial discounts on the purchase price of standards, both in single copy and subscription format, by becoming a **BSI Subscribing Member**.

**PLUS** is an updating service exclusive to BSI Subscribing Members. You will automatically receive the latest hard copy of your standards when they're revised or replaced.

To find out more about becoming a BSI Subscribing Member and the benefits of membership, please visit [bsigroup.com/shop](http://bsigroup.com/shop).

With a **Multi-User Network Licence (MUNL)** you are able to host standards publications on your intranet. Licences can cover as few or as many users as you wish. With updates supplied as soon as they're available, you can be sure your documentation is current. For further information, email [subscriptions@bsigroup.com](mailto:subscriptions@bsigroup.com).

## Revisions

Our British Standards and other publications are updated by amendment or revision.

We continually improve the quality of our products and services to benefit your business. If you find an inaccuracy or ambiguity within a British Standard or other BSI publication please inform the Knowledge Centre.

## Useful Contacts

### Customer Services

**Tel:** +44 345 086 9001

**Email (orders):** [orders@bsigroup.com](mailto:orders@bsigroup.com)

**Email (enquiries):** [cservices@bsigroup.com](mailto:cservices@bsigroup.com)

### Subscriptions

**Tel:** +44 345 086 9001

**Email:** [subscriptions@bsigroup.com](mailto:subscriptions@bsigroup.com)

### Knowledge Centre

**Tel:** +44 20 8996 7004

**Email:** [knowledgecentre@bsigroup.com](mailto:knowledgecentre@bsigroup.com)

### Copyright & Licensing

**Tel:** +44 20 8996 7070

**Email:** [copyright@bsigroup.com](mailto:copyright@bsigroup.com)

### BSI Group Headquarters

389 Chiswick High Road London W4 4AL UK