



BSI Standards Publication

**Safety requirements for  
electrical equipment for  
measurement, control, and  
laboratory use — General  
requirements for equipment  
intended to be used in  
educational establishments  
by children**

NO COPYING WITHOUT BSI PERMISSION EXCEPT AS PERMITTED BY COPYRIGHT LAW

### **National foreword**

This Published Document is the UK implementation of IEC/TS 62850:2013. It supersedes DD 61010-100:2007 which is withdrawn.

The UK participation in its preparation was entrusted to Technical Committee EPL/66, Safety of measuring, control and laboratory equipment.

A list of organizations represented on this committee can be obtained on request to its secretary.

This publication does not purport to include all the necessary provisions of a contract. Users are responsible for its correct application.

© The British Standards Institution 2013

Published by BSI Standards Limited 2013

ISBN 978 0 580 67048 0

ICS 19.080

**Compliance with a British Standard cannot confer immunity from legal obligations.**

This Published Document was published under the authority of the Standards Policy and Strategy Committee on 30 April 2013.

### **Amendments issued since publication**

<b>Amd. No.</b>	<b>Date</b>	<b>Text affected</b>
-----------------	-------------	----------------------

---



# TECHNICAL SPECIFICATION

# SPÉCIFICATION TECHNIQUE

---

**Safety requirements for electrical equipment for measurement, control, and laboratory use –  
General requirements for equipment intended to be used in educational establishments by children**

**Règles de sécurité pour appareils électriques de mesurage, de régulation et de laboratoire –  
Règles générales pour appareils destinés à une utilisation dans les établissements scolaires par des enfants**

INTERNATIONAL  
ELECTROTECHNICAL  
COMMISSION

COMMISSION  
ELECTROTECHNIQUE  
INTERNATIONALE

PRICE CODE **XH**  
CODE PRIX

---

ICS 19.080

ISBN 978-2-83220-655-3

**Warning! Make sure that you obtained this publication from an authorized distributor.  
Attention! Veuillez vous assurer que vous avez obtenu cette publication via un distributeur agréé.**

## CONTENTS

FOREWORD.....	10
INTRODUCTION.....	12
1 Scope and object.....	13
1.1 Scope.....	13
1.1.1 Equipment included in scope .....	13
1.1.2 Equipment excluded from scope .....	13
1.1.3 Computing equipment.....	14
1.2 Object .....	14
1.2.1 Aspects included in scope .....	14
1.2.2 Aspects excluded from scope .....	15
1.3 Verification .....	15
1.4 Environmental conditions .....	15
1.4.1 Normal environmental conditions .....	15
1.4.2 Extended environmental conditions .....	15
2 Normative references .....	16
3 Terms and definitions .....	18
3.1 Equipment and states of equipment.....	18
3.2 Parts and accessories .....	18
3.3 Quantities.....	19
3.4 Tests .....	20
3.5 Safety terms .....	20
3.6 Insulation .....	22
4 Tests .....	23
4.1 General .....	23
4.2 Sequence of tests .....	24
4.3 Reference test conditions .....	24
4.3.1 Environmental conditions.....	24
4.3.2 State of equipment .....	24
4.4 Testing in SINGLE FAULT CONDITION .....	26
4.4.1 General .....	26
4.4.2 Application of fault conditions .....	26
4.4.3 Duration of tests .....	29
4.4.4 Conformity after application of fault conditions.....	29
5 Marking and documentation.....	30
5.1 Marking .....	30
5.1.1 General .....	30
5.1.2 Identification.....	30
5.1.3 MAINS supply .....	30
5.1.4 Fuses .....	32
5.1.5 TERMINALS, connections and operating devices.....	32
5.1.6 Switches and circuit-breakers .....	33
5.1.7 Equipment protected by DOUBLE INSULATION or REINFORCED INSULATION .....	33
5.1.8 Field-wiring TERMINAL boxes .....	34
5.2 Warning markings .....	34
5.3 Durability of markings.....	34
5.4 Documentation .....	35

5.4.1	General .....	35
5.4.2	Equipment RATINGS .....	35
5.4.3	Equipment installation .....	36
5.4.4	Equipment operation .....	36
5.4.5	Equipment maintenance and service .....	37
5.4.6	Integration into systems or effects resulting from special conditions .....	37
6	Protection against electric shock .....	38
6.1	General .....	38
6.1.1	Requirements .....	38
6.1.2	Exceptions .....	38
6.2	Determination of ACCESSIBLE parts .....	38
6.2.1	General .....	38
6.2.2	Examination .....	39
6.2.3	<del>Not used</del> Openings above parts that are HAZARDOUS LIVE .....	39
6.2.4	<del>Not used</del> Openings for pre-set controls .....	39
6.2.5	Additional determination for all openings except TERMINALS .....	40
6.3	Limit values for ACCESSIBLE parts .....	40
6.3.1	Levels in NORMAL CONDITION .....	40
6.3.2	Levels in SINGLE FAULT CONDITION .....	40
6.4	Primary means of protection .....	43
6.4.1	General .....	43
6.4.2	ENCLOSURES and PROTECTIVE BARRIERS .....	43
6.4.3	BASIC INSULATION .....	43
6.4.4	Impedance .....	43
6.5	Additional means of protection in case of SINGLE FAULT CONDITIONS .....	43
6.5.1	General .....	43
6.5.2	PROTECTIVE BONDING .....	44
6.5.3	SUPPLEMENTARY INSULATION and REINFORCED INSULATION .....	47
6.5.4	PROTECTIVE IMPEDANCE .....	47
6.5.5	Automatic disconnection of the supply .....	48
6.5.6	Current- or voltage-limiting device .....	48
6.6	Connections to external circuits .....	48
6.6.1	General .....	48
6.6.2	TERMINALS for external circuits .....	49
6.6.3	Circuits with TERMINALS which are HAZARDOUS LIVE .....	49
6.6.4	TERMINALS for stranded conductors .....	49
6.7	Insulation requirements .....	50
6.7.1	The nature of insulation .....	50
6.7.2	Insulation for MAINS CIRCUITS of OVERVOLTAGE CATEGORY II with a nominal supply voltage up to 300 V .....	52
6.7.3	Insulation for secondary circuits derived from MAINS CIRCUITS of OVERVOLTAGE CATEGORY II up to 300 V .....	56
6.8	Procedure for voltage tests .....	61
6.8.1	General .....	61
6.8.2	Humidity preconditioning .....	62
6.8.3	Test procedures .....	63
6.9	Constructional requirements for protection against electric shock .....	63
6.9.1	General .....	63
6.9.2	Insulating materials .....	64

6.9.3	Colour coding .....	64
6.10	Connection to the MAINS supply source and connections between parts of equipment .....	64
6.10.1	MAINS supply cords .....	64
6.10.2	Fitting of non-detachable MAINS supply cords .....	65
6.10.3	Plugs and connectors .....	67
6.11	Disconnection from supply source .....	67
6.11.1	General .....	67
6.11.2	Exceptions .....	67
6.11.3	Requirements according to type of equipment .....	67
6.11.4	Disconnecting devices .....	68
7	Protection against mechanical HAZARDS .....	69
7.1	General .....	69
7.2	Sharp edges .....	69
7.3	Moving parts .....	69
7.3.1	General .....	69
7.3.2	Exceptions .....	69
7.3.3	RISK assessment for mechanical HAZARDS to body parts .....	70
7.3.4	Limitation of force and pressure .....	71
7.3.5	Gap limitations between moving parts .....	71
7.4	Stability .....	73
7.5	Provisions for lifting and carrying .....	74
7.5.1	General .....	74
7.5.2	Handles and grips .....	74
7.5.3	Lifting devices and supporting parts .....	74
7.6	Wall mounting .....	75
7.7	Expelled parts .....	75
8	Resistance to mechanical stresses .....	75
8.1	General .....	75
8.2	ENCLOSURE rigidity tests .....	76
8.2.1	Static test .....	76
8.2.2	Impact test .....	77
8.3	Drop test .....	78
8.3.1	Equipment other than HAND-HELD EQUIPMENT and DIRECT PLUG-IN EQUIPMENT .....	78
8.3.2	HAND-HELD EQUIPMENT and DIRECT PLUG-IN EQUIPMENT .....	78
9	Protection against the spread of fire .....	78
9.1	General .....	78
9.2	Eliminating or reducing the sources of ignition within the equipment .....	80
9.3	Containment of fire within the equipment, should it occur .....	80
9.3.1	General .....	80
9.3.2	Constructional requirements .....	80
9.4	Limited-energy circuit .....	83
9.5	Requirements for equipment containing or using flammable liquids .....	84
9.6	Overcurrent protection .....	84
9.6.1	General .....	84
9.6.2	PERMANENTLY CONNECTED EQUIPMENT .....	85
9.6.3	Other equipment .....	85
10	Equipment temperature limits and resistance to heat .....	85

10.1	Surface temperature limits for protection against burns .....	85
10.2	Temperatures of windings .....	86
10.3	Other temperature measurements .....	87
10.4	Conduct of temperature tests .....	87
10.4.1	General .....	87
10.4.2	Temperature measurement of heating equipment .....	87
10.4.3	Equipment intended for installation in a cabinet or a wall .....	88
10.5	Resistance to heat .....	88
10.5.1	Integrity of CLEARANCES and CREEPAGE DISTANCES .....	88
10.5.2	Non-metallic ENCLOSURES .....	88
10.5.3	Insulating material .....	88
11	Protection against HAZARDS from fluids .....	89
11.1	General .....	89
11.2	Cleaning .....	90
11.3	Spillage .....	90
11.4	Overflow .....	90
11.5	Battery electrolyte .....	90
11.6	Specially protected equipment .....	91
11.7	Fluid pressure and leakage .....	91
11.7.1	Maximum pressure .....	91
11.7.2	Leakage and rupture at high pressure .....	91
11.7.3	Leakage from low-pressure parts .....	92
11.7.4	Overpressure safety device .....	92
12	Protection against radiation, including laser sources, and against sonic and ultrasonic pressure .....	92
12.1	General .....	92
12.2	Equipment producing ionizing radiation .....	92
12.2.1	Ionizing radiation .....	92
12.2.2	Accelerated electrons .....	94
12.3	<del>Ultraviolet (UV) Optical radiation</del> .....	94
12.4	Microwave radiation .....	95
12.5	Sonic and ultrasonic pressure .....	95
12.5.1	Sound level .....	95
12.5.2	Ultrasonic pressure .....	95
12.6	Laser sources .....	96
13	Protection against liberated gases and substances, explosion and implosion .....	96
13.1	Poisonous and injurious gases and substances .....	96
13.2	Explosion and implosion .....	97
13.2.1	Components .....	97
13.2.2	Batteries and battery charging .....	97
13.2.3	Implosion of cathode ray tubes .....	97
14	Components and subassemblies .....	98
14.1	General .....	98
14.2	Motors .....	99
14.2.1	Motor temperatures .....	99
14.2.2	Series excitation motors .....	99
14.3	Overtemperature protection devices .....	100
14.4	Fuse holders .....	100
14.5	MAINS voltage selection devices .....	100

14.6	MAINS transformers tested outside equipment.....	100
14.7	Printed wiring boards.....	101
14.8	Circuits or components used as TRANSIENT OVERVOLTAGE limiting devices .....	101
14.9	<u>Small components</u> .....	102
15	Protection by interlocks .....	102
15.1	General .....	102
15.2	Prevention of reactivating .....	102
15.3	Reliability .....	102
16	HAZARDS resulting from application .....	103
16.1	REASONABLY FORESEEABLE MISUSE.....	103
16.2	Ergonomic aspects .....	103
17	RISK assessment .....	103
Annex A (normative)	Measuring circuits for touch current (see 6.3).....	105
Annex B (normative)	Standard test fingers (see 6.2).....	109
Annex C (normative)	Measurement of CLEARANCES and CREEPAGE DISTANCES .....	112
Annex D (normative)	Parts between which insulation requirements are specified (see 6.4 and 6.5.3) .....	116
Annex E (informative)	Guideline for reduction of POLLUTION DEGREES .....	119
Annex F (normative)	ROUTINE TESTS.....	120
Annex G (informative)	Leakage and rupture from fluids under pressure .....	122
Annex H (normative)	Qualification of conformal coatings for protection against POLLUTION .....	127
Annex I (informative)	Line-to-neutral voltages for common MAINS supply systems .....	130
Annex J (informative)	RISK assessment .....	131
Annex K (normative)	Insulation requirements not covered by 6.7 .....	134
Annex L (informative)	Index of defined terms .....	156
	Bibliography.....	158
	Figure 1 – Measurements through openings in ENCLOSURES.....	39
	Figure 2 – Maximum duration of short-term ACCESSIBLE voltages in SINGLE FAULT CONDITION (see 6.3.2 a)) .....	41
	Figure 3 – Capacitance level versus voltage in NORMAL CONDITION and SINGLE FAULT CONDITION (see 6.3.1 c) and 6.3.2 c)) .....	42
	Figure 4 – Acceptable arrangement of protective means against electric shock .....	44
	Figure 5 – Examples of binding screw assemblies .....	46
	Figure 6 – Distance between conductors on an interface between two layers.....	54
	Figure 7 – Distance between adjacent conductors along an interface of two inner layers .....	54
	Figure 8 – Distance between adjacent conductors located between the same two layers .....	55
	Figure 9 – Detachable MAINS supply cords and connections .....	65
	Figure 10 – Impact test using a sphere .....	77
	Figure 11 – Flow chart to explain the requirements for protection against the spread of fire.....	79
	Figure 12 – Baffle .....	82
	Figure 13 – Area of the bottom of an ENCLOSURE to be constructed as specified in 9.3.2 c) 1).....	82



Figure 14 – Ball-pressure test apparatus .....	89
Figure 15 – Flow chart for conformity options 14.1 a), b), c) and d).....	99
<u>Figure 16 – Cylinder for checking the size of small components</u> .....	102
Figure A.1 – Measuring circuit for a.c. with frequencies up to 1 MHz and for d.c. ....	105
Figure A.2 – Measuring circuits for sinusoidal a.c. with frequencies up to 100 Hz and for d.c. ....	106
Figure A.3 – Current measuring circuit for electrical burns .....	107
Figure A.4 – Current measuring circuit for wet contact .....	108
Figure B.1 – Rigid test finger .....	109
Figure B.2 – Jointed test finger .....	110
<u>Figure B.3 – Jointed test probe for equipment intended to be used by CHILDREN</u> .....	111
Figure C.1 – Examples of methods of measuring CLEARANCES and CREEPAGE DISTANCES .....	115
Figures D.1 a) to d) – Protection between HAZARDOUS LIVE circuits and ACCESSIBLE parts .....	117
Figures D.1 e) to h) – Protection between HAZARDOUS LIVE circuits and circuits which ACCESSIBLE external TERMINALS .....	117
Figures D.2 a) and b) – Protection between a HAZARDOUS LIVE internal circuit and an ACCESSIBLE part which is not bonded to other ACCESSIBLE parts .....	118
Figures D.2 c) and d) – Protection between a HAZARDOUS LIVE primary circuit and circuits which have ACCESSIBLE external TERMINALS .....	118
Figure D.3 – Protection of external ACCESSIBLE TERMINALS of two HAZARDOUS LIVE circuits .....	118
Figure G.1 – Conformity verification process (see G.2) .....	123
Figure H.1 – Test sequence and conformity .....	129
Figure J.1 – Iterative process of RISK assessment and RISK reduction .....	131
Figure J.2 – RISK reduction .....	132
Figure K.1 – Distance between conductors on an interface between two layers .....	139
Figure K.2 – Distance between adjacent conductors along an interface of an inner layer .....	139
Figure K.3 – Distance between adjacent conductors located between the same two layers .....	140
Figure K.4 – Example of recurring peak voltage .....	153
Table 1 – Symbols .....	31
Table 2 – Tightening torque for binding screw assemblies .....	46
Table 3 – Multiplication factors for CLEARANCES of equipment RATED for operation at altitudes up to 5 000 m .....	51
Table 4 – CLEARANCES and CREEPAGE DISTANCES for MAINS CIRCUITS of OVERVOLTAGE CATEGORY II up to 300 V .....	53
Table 5 – Test voltages for solid insulation in MAINS CIRCUITS of OVERVOLTAGE CATEGORY II up to 300 V.....	53
Table 6 – CLEARANCES and test voltages for secondary circuits derived from MAINS CIRCUITS of OVERVOLTAGE CATEGORY II up to 300 V .....	57
Table 7 – CREEPAGE DISTANCES for secondary circuits .....	58
Table 8 – Minimum values for distance or thickness (see 6.7.3.4.2 to 6.7.3.4.4) .....	60
Table 9 – Distances between TERMINALS and foil.....	61

Table 10 – Correction factors according to test site altitude for test voltages for CLEARANCES .....	62
Table 11 – Values for physical tests on cord anchorages .....	66
Table 12 – Protective measures against mechanical HAZARDS to body parts.....	70
Table 13 – Minimum maintained gaps to prevent crushing for different body parts .....	72
Table 14 – Maximum gaps to prevent access for different body parts.....	73
Table 15 – Impact energy levels, test height and corresponding IK codes .....	78
Table 16 – Acceptable perforation of the bottom of an ENCLOSURE .....	81
Table 17 – Limits of maximum available current.....	83
Table 18 – Values for overcurrent protection devices .....	84
Table 19 – Surface temperature limits in NORMAL CONDITION.....	86
Table 20 – Maximum temperatures for insulation material of windings .....	87
<u>Table 21 – Lamp or lamp systems considered photobiologically safe</u> .....	94
<u>Table 22 – Lamp or lamp systems considered photobiologically conditionally safe</u> .....	94
<u>Table 23</u> <del>Table 24</del> – Impulse withstand voltages for OVERVOLTAGE CATEGORY II.....	101
Table C.1 – Dimensions of X.....	112
Table E.1 – Environmental situations .....	119
Table E.2 – Reduction of POLLUTION DEGREES .....	119
Table F.1 – Test voltages for ROUTINE TESTS of MAINS CIRCUITS .....	121
Table G.1 – Test pressures for equipment with pressures above 14 MPa.....	125
Table H.1 – Test parameters, test conditions and test procedures .....	128
Table I.1 – Line-to-neutral voltages for common MAINS supply systems .....	130
Table J.1 – Severity of harm .....	133
Table J.2 – Probability of harm .....	133
Table J.3 – RISK category .....	133
Table K.1 – Multiplication factors for CLEARANCES for equipment RATED for operation at altitudes up to 5 000 m .....	135
Table K.2 – CLEARANCES and CREEPAGE DISTANCES for MAINS CIRCUITS of OVERVOLTAGE CATEGORY II above 300 V.....	135
Table K.3 – CLEARANCES and CREEPAGE DISTANCES for MAINS CIRCUITS of OVERVOLTAGE CATEGORY III .....	136
Table K.4 – CLEARANCES and CREEPAGE DISTANCES for MAINS CIRCUITS of OVERVOLTAGE CATEGORY IV .....	136
Table K.5 – Test voltages for solid insulation in MAINS CIRCUITS of OVERVOLTAGE CATEGORY II above 300 V .....	137
Table K.6 – Test voltages for solid insulation in MAINS CIRCUITS of OVERVOLTAGE CATEGORY III .....	137
Table K.7 – Test voltages for solid insulation in MAINS CIRCUITS of OVERVOLTAGE CATEGORY IV .....	138
Table K.8 – Test voltages for testing long-term stress of solid insulation in MAINS CIRCUITS.....	138
Table K.9 – Minimum values for distance or thickness of solid insulation .....	139
Table K.10 – CLEARANCES and test voltages for secondary circuits derived from MAINS CIRCUITS of OVERVOLTAGE CATEGORY II above 300 V .....	142
Table K.11 – CLEARANCES and test voltages for secondary circuits derived from MAINS CIRCUITS of OVERVOLTAGE CATEGORY III.....	143

Table K.12 – CLEARANCES and test voltages for secondary circuits derived from MAINS CIRCUITS of OVERVOLTAGE CATEGORY IV .....	144
Table K.13 – CREEPAGE DISTANCES for secondary circuits.....	145
Table K.14 – Minimum values for distance or thickness (see K.2.4.2 to K.2.4.4) .....	147
Table K.15 – CLEARANCE values for the calculation of K.3.2 .....	151
Table K.16 – Test voltages based on CLEARANCES .....	152
Table K.17 – CLEARANCES for BASIC INSULATION in circuits having recurring peak voltages or WORKING VOLTAGES with frequencies above 30 kHz .....	154

## INTERNATIONAL ELECTROTECHNICAL COMMISSION

---

### **SAFETY REQUIREMENTS FOR ELECTRICAL EQUIPMENT FOR MEASUREMENT, CONTROL, AND LABORATORY USE –**

#### **General requirements for equipment intended to be used in educational establishments by children**

#### FOREWORD

- 1) The International Electrotechnical Commission (IEC) is a worldwide organization for standardization comprising all national electrotechnical committees (IEC National Committees). The object of IEC is to promote international co-operation on all questions concerning standardization in the electrical and electronic fields. To this end and in addition to other activities, IEC publishes International Standards, Technical Specifications, Technical Reports, Publicly Available Specifications (PAS) and Guides (hereafter referred to as "IEC Publication(s)"). Their preparation is entrusted to technical committees; any IEC National Committee interested in the subject dealt with may participate in this preparatory work. International, governmental and non-governmental organizations liaising with the IEC also participate in this preparation. IEC collaborates closely with the International Organization for Standardization (ISO) in accordance with conditions determined by agreement between the two organizations.
- 2) The formal decisions or agreements of IEC on technical matters express, as nearly as possible, an international consensus of opinion on the relevant subjects since each technical committee has representation from all interested IEC National Committees.
- 3) IEC Publications have the form of recommendations for international use and are accepted by IEC National Committees in that sense. While all reasonable efforts are made to ensure that the technical content of IEC Publications is accurate, IEC cannot be held responsible for the way in which they are used or for any misinterpretation by any end user.
- 4) In order to promote international uniformity, IEC National Committees undertake to apply IEC Publications transparently to the maximum extent possible in their national and regional publications. Any divergence between any IEC Publication and the corresponding national or regional publication shall be clearly indicated in the latter.
- 5) IEC itself does not provide any attestation of conformity. Independent certification bodies provide conformity assessment services and, in some areas, access to IEC marks of conformity. IEC is not responsible for any services carried out by independent certification bodies.
- 6) All users should ensure that they have the latest edition of this publication.
- 7) No liability shall attach to IEC or its directors, employees, servants or agents including individual experts and members of its technical committees and IEC National Committees for any personal injury, property damage or other damage of any nature whatsoever, whether direct or indirect, or for costs (including legal fees) and expenses arising out of the publication, use of, or reliance upon, this IEC Publication or any other IEC Publications.
- 8) Attention is drawn to the Normative references cited in this publication. Use of the referenced publications is indispensable for the correct application of this publication.
- 9) Attention is drawn to the possibility that some of the elements of this IEC Publication may be the subject of patent rights. IEC shall not be held responsible for identifying any or all such patent rights.

The main task of IEC technical committees is to prepare International Standards. In exceptional circumstances, a technical committee may propose the publication of a technical specification when

- the required support cannot be obtained for the publication of an International Standard, despite repeated efforts, or
- the subject is still under technical development or where, for any other reason, there is the future but no immediate possibility of an agreement on an International Standard.

Technical specifications are subject to review within three years of publication to decide whether they can be transformed into International Standards.

IEC/TS 62850, which is a technical specification, has been prepared by technical committee 66: Safety of measuring, control and laboratory equipment.

This first edition is based on the third edition (2010) of IEC 61010-1.

The text of this technical specification is based on the following documents:

Enquiry draft	Report on voting
66/456/DTS	66/475/RVC

Full information on the voting for the approval of this technical specification can be found in the report on voting indicated in the above table.

This publication has been drafted in accordance with the ISO/IEC Directives, Part 2.

In this Technical Specification, the following print types are used:

- requirements and definitions: in roman type;
- NOTES: in smaller roman type;
- *conformity and tests*: in italic type;
- terms used throughout this Technical Specification which have been defined in Clause 3: SMALL ROMAN CAPITALS.

Technical and major editorial changes from IEC 61010-1 are indicated as follows: added text is underlined (added text) and deleted text is struck out (~~deleted text~~). Minor editorial changes are not indicated.

The committee has decided that the contents of this publication will remain unchanged until the stability date indicated on the IEC web site under "<http://webstore.iec.ch>" in the data related to the specific publication. At this date, the publication will be

- transformed into an International Standard,
- reconfirmed,
- withdrawn,
- replaced by a revised edition, or
- amended.

**IMPORTANT – The 'colour inside' logo on the cover page of this publication indicates that it contains colours which are considered to be useful for the correct understanding of its contents. Users should therefore print this document using a colour printer.**

## INTRODUCTION

Based on a TC 66 decision at the plenary meeting held in Everett on 2010-09-03, it was agreed that as an interim solution this document is to be published as a Technical Specification. This document publishes provisions pertaining to the use of this equipment by children in educational establishments which, if the provisions prove useful, are intended to be integrated into a future edition of IEC 61010-1. This publication will be reviewed in accordance with the rules of Part 1 of the ISO/IEC Directives where it is stated that a Technical Specification has to be reviewed within 3 years of its publication with the options of extension for another 3 years; conversion to an International Standard; or withdrawal.

This Technical Specification includes the following significant changes with respect to IEC 61010-1:2010, as well as other changes:

- a) a marking is added to indicate the age of CHILDREN by whom the equipment is intended to be used;
- b) accessibility requirements are enhanced to take into account the propensity of CHILDREN to insert foreign objects wherever they can;
- c) temperature limits have been decreased to take into account the greater sensitivity of a CHILD'S skin;
- d) mechanical access dimensions have been reduced to take into account the smaller dimensions of a CHILD'S body;
- e) limits for non-collimated optical radiation have been introduced;
- f) limits for ionizing radiation have been reduced;
- g) small detachable parts below certain dimensions have been prohibited;
- h) manufacturers are required to take into account the general unpredictability of the behaviour of CHILDREN.

Electrical equipment dealt with in this Technical Specification is used for teaching CHILDREN under the age of 16 in educational establishments.

CHILDREN are likely to poke objects and materials through apertures into the interior of electrical equipment. Consequently, more stringent criteria for access to HAZARDOUS LIVE conductors are required for educational establishment equipment than for general laboratory use. Moreover, the temperatures of parts that may be touched by CHILDREN should be lower than for equipment that is handled only by adults. Ergonomic considerations and mechanical RISKS need to be addressed with regard to the anthropomorphic dimensions of CHILDREN instead of adults. Requirements for equipment to be used by CHILDREN must also take into account REASONABLY FORESEEABLE MISUSE and the unpredictable behaviour of CHILDREN.

This Technical Specification addresses the safety requirements for equipment within the scope of IEC 61010 to be used by children between the ages of 3 and 16 in educational establishments, when supervised by the RESPONSIBLE BODY.

For certain types of equipment, these requirements will be supplemented or modified by the special requirements of one, or more than one, particular part 2 of the IEC 61010 series which must be read in conjunction with the requirements of this technical specification. In that case this IEC/TS 62850 is to be considered the alternative for IEC 61010-1.

## **SAFETY REQUIREMENTS FOR ELECTRICAL EQUIPMENT FOR MEASUREMENT, CONTROL, AND LABORATORY USE –**

### **General requirements for equipment intended to be used in educational establishments by children**

## **1 Scope and object**

### **1.1 Scope**

#### **1.1.1 Equipment included in scope**

~~This part of IEC 61010 specifies general safety requirements for the following types of electrical equipment and their accessories, wherever they are intended to be used.~~

This Technical Specification IEC 62850 specifies general safety requirements for the following types of equipment and their accessories intended to be used in educational establishments by persons between the age of 3 years and the age of 16 years under the supervision of the RESPONSIBLE BODY.

If all or part of the equipment falls within the scope of one or more part 2 standards of IEC 61010 as well as within the scope of this technical specification, it will also need to meet the requirements of those other part 2 standards.

NOTE 1 In some countries age limits can be different from those used in this technical specification or can be replaced by capability requirements.

#### **a) Electrical test and measurement equipment**

This is equipment which by electromagnetic means tests, measures, indicates or records one or more electrical or physical quantities, also non-measuring equipment such as signal generators, measurement standards, power supplies for laboratory use, transducers, transmitters, etc.

NOTE 2 This includes bench-top power supplies intended to aid a testing or measuring operation on another piece of equipment. Power supplies intended to power equipment are within the scope of IEC 61558 (see 1.1.2 h)).

This Technical Specification also applies to test equipment integrated into manufacturing processes and intended for testing manufactured devices.

NOTE 3 Manufacturing test equipment is likely to be installed adjacent to and interconnected with industrial machinery in this application.

#### **b) Electrical industrial process-control equipment**

This is equipment which controls one or more output quantities to specific values, with each value determined by manual setting, by local or remote programming, or by one or more input variables.

#### **c) Electrical laboratory equipment**

This is equipment which measures, indicates, monitors, inspects or analyses materials, or is used to prepare materials, and includes in vitro diagnostic (IVD) equipment.

~~This equipment may also be used in areas other than laboratories; examples include self-test IVD equipment to be used in the home and inspection equipment to be used to check people or material during transportation.~~

#### **1.1.2 Equipment excluded from scope**

This Technical Specification does not apply to equipment within the scope of:

- a) IEC 60065 (Audio, video and similar electronic apparatus);
- b) IEC 60204 (Safety of machinery – Electrical equipment of machines);
- c) IEC 60335 (Household and similar electrical appliances);
- d) IEC 60364 (Electrical installations of buildings);
- e) IEC ~~60439~~ 61439-1 (Low-voltage switchgear and controlgear assemblies);
- f) IEC 60601 (Medical electrical equipment);
- g) IEC 60950 (Information technology equipment including electrical business equipment, except as specified in 1.1.3);
- h) IEC 61558 (Power transformers, power supply units and similar);
- i) IEC 61010-031 (Hand-held probe assemblies);
- j) IEC 61243-3 (Live working – Voltage detectors – Part 3: Two-pole low-voltage type).

### 1.1.3 Computing equipment

This Technical Specification applies only to computers, processors, etc. which form part of equipment within the scope of this Technical Specification or are designed for use exclusively with the equipment.

NOTE Computing devices and similar equipment within the scope of IEC 60950 and conforming to its requirements are considered to be suitable for use with equipment within the scope of this Technical Specification. However, some of the requirements of IEC 60950 for resistance to moisture and liquids are less stringent than those in this Technical Specification (see 5.4.4 second paragraph).

## 1.2 Object

### 1.2.1 Aspects included in scope

The purpose of the requirements of this Technical Specification is to ensure that HAZARDS to the OPERATOR and the surrounding area are reduced to a tolerable level.

Requirements for protection against particular types of HAZARD are given in Clauses 6 to 13, as follows:

- a) electric shock or burn (see Clause 6);
- b) mechanical HAZARDS (see Clauses 7 and 8);
- c) spread of fire from the equipment (see Clause 9);
- d) excessive temperature (see Clause 10);
- e) effects of fluids and fluid pressure (see Clause 11);
- f) effects of radiation, including lasers sources, and sonic and ultrasonic pressure (see Clause 12);
- g) liberated gases, explosion and implosion (see Clause 13).

Requirements for protection against HAZARDS arising from REASONABLY FORESEEABLE MISUSE and ergonomic factors are specified in Clause 16.

RISK assessment for HAZARDS or environments not fully covered above is specified in Clause 17.

~~NOTE Attention is drawn to the existence of additional requirements regarding the health and safety of labour forces.~~

NOTE 1 Attention is drawn to the additional requirements that can be specified by national authorities responsible for health and safety in education. In particular, there can be limitations on the use of radioactive materials, X-ray and laser equipment, and hazardous substances.

NOTE 2 Attention is also drawn to the existence of additional requirements that can be specified by national authorities responsible for the health and safety of CHILDREN in education with special needs.



## 1.2.2 Aspects excluded from scope

This Technical Specification does not cover:

- a) reliable function, performance, or other properties of the equipment not related to safety;
- b) effectiveness of transport packaging;
- c) EMC requirements (see the IEC 61326 series);
- d) protective measures for explosive atmospheres (see the IEC 60079 series).

## 1.3 Verification

This Technical Specification also specifies methods of verifying that the equipment meets the requirements of this Technical Specification, through inspection, TYPE TESTS, ROUTINE TESTS, and RISK assessment.

## 1.4 Environmental conditions

### 1.4.1 Normal environmental conditions

This Technical Specification applies to equipment designed to be safe at least under the following conditions:

- a) indoor use;
- b) altitude up to 2 000 m;
- c) temperature 5 °C to 40 °C;
- d) maximum relative humidity 80 % for temperatures up to 31 °C decreasing linearly to 50 % relative humidity at 40 °C;
- e) MAINS supply voltage fluctuations up to  $\pm 10$  % of the nominal voltage;
- f) TRANSIENT OVERVOLTAGES up to the levels of OVERVOLTAGE CATEGORY II;  
NOTE-4 These levels of TRANSIENT OVERVOLTAGE are typical for equipment supplied from the building wiring.
- g) TEMPORARY OVERVOLTAGES occurring on the MAINS supply;
- h) applicable POLLUTION DEGREE of the intended environment (POLLUTION DEGREE 2 in most cases).

**NOTE 2**—Manufacturers may specify more restricted environmental conditions for operation; nevertheless the equipment shall be safe within these normal environmental conditions.

### 1.4.2 Extended environmental conditions

This Technical Specification applies to equipment designed to be safe not only in the environmental conditions specified in 1.4.1, but also in any of the following conditions as RATED by the manufacturer of the equipment:

- a) outdoor use;
- b) altitude above 2 000 m;
- c) ambient temperatures below 5 °C or above 40 °C;
- d) relative humidity above the levels specified in 1.4.1;
- e) MAINS supply voltage fluctuations exceeding  $\pm 10$  % of the nominal voltage;
- f) WET LOCATION;
- g) TRANSIENT OVERVOLTAGES up to the levels of OVERVOLTAGE CATEGORY III or IV (see Annex K).

## 2 Normative references

The following documents, in whole or in part, are normatively referenced in this document and are indispensable for its application. For dated references, only the edition cited applies. For undated references, the latest edition of the referenced document (including any amendments) applies.

IEC 60027-1, *Letter symbols to be used in electrical technology – Part 1: General*

IEC 60065, *Audio, video and similar electronic apparatus – Safety requirements*

IEC 60068-2-14, *Environmental testing – Part 2-14: Tests – Test N: Change of temperature*

IEC 60068-2-75, *Environmental testing – Part 2-75: Tests – Test Eh: Hammer tests*

IEC 60073, *Basic and safety principles for man-machine interface, marking and identification – Coding principles for indicators and actuators*

IEC 60227-1, *Polyvinyl chloride insulated cables of rated voltages up to and including 450/750 V – Part 1: General requirements*

IEC 60245-1, *Rubber insulated cables – Rated voltages up to and including 450/750 V – Part 1: General requirements*

IEC 60309-1, *Plugs, socket-outlets and couplers for industrial purposes – Part 1: General requirements*

IEC 60320 (all parts), *Appliance couplers for household and similar general purposes*

IEC 60332-1-2, *Tests on electric and optical fibre cables under fire conditions – Part 1-2: Test for vertical flame propagation for a single insulated wire or cable – Procedure for 1 kW pre-mixed flame*

IEC 60332-2-2, *Tests on electric and optical fibre cables under fire conditions – Part 2-2: Test for vertical flame propagation for a single small insulated wire or cable – Procedure for diffusion flame*

IEC 60335-2-24, *Household and similar electrical appliances – Safety – Part 2-24: Particular requirements for refrigerating appliances, ice-cream appliances and ice-makers*

IEC 60335-2-89, *Household and similar electrical appliances – Safety – Part 2-89: Particular requirements for commercial refrigerating appliances with an incorporated or remote refrigerant unit or compressor*

~~IEC 60364-4-44, *Low voltage electrical installations – Part 4-44: Protection for safety – Protection against voltage disturbances and electromagnetic disturbances*~~

~~IEC 60405, *Nuclear instrumentation – Constructional requirements and classification of radiometric gauges*~~

IEC 60417, *Graphical symbols for use on equipment. Available from: <<http://www.graphical-symbols.info/equipment>>*

IEC 60529, *Degrees of protection provided by enclosures (IP Code)*

IEC 60664-3:2003, *Insulation coordination for equipment within low-voltage systems – Part 3: Use of coating, potting or moulding for protection against pollution*  
Amendment 1:2010

IEC 60695-11-10, *Fire hazard testing – Part 11-10: Test flames – 50 W horizontal and vertical flame test methods*

IEC 60799, *Electrical accessories – Cord sets and interconnection cord sets*

IEC 60825-1, *Safety of laser products – Part 1: Equipment classification and requirements*

IEC 60947-1, *Low-voltage switchgear and controlgear – Part 1: General rules*

IEC 60947-3, *Low-voltage switchgear and controlgear – Part 3: Switches, disconnectors, switch-disconnectors and fuse-combination units*

~~IEC 61010-031, *Safety requirements for electrical equipment for measurement, control and laboratory use – Part 031: Safety requirements for hand-held probe assemblies for electrical measurement and test*~~

~~IEC 61180 (all parts), *High-voltage test techniques for low-voltage equipment*~~

IEC 61180-1:1992, *High-voltage test techniques for low-voltage equipment – Part 1: Definitions, test and procedure requirements*

IEC 61180-2, *High-voltage test techniques for low-voltage equipment – Part 2: Test equipment*

IEC 61672-1, *Electroacoustics – Sound level meters – Part 1: Specifications*

IEC 61672-2, *Electroacoustics – Sound level meters – Part 2: Pattern evaluation tests*

IEC 62262, *Degrees of protection provided by enclosures for electrical equipment against external impacts (IK code)*

IEC 62471, *Photobiological safety of lamps and lamp systems*

IEC/TR 62471-2, *Photobiological safety of lamps and lamp systems – Part 2: Guidance on manufacturing requirements relating to non-laser optical radiation safety*

IEC 62598, *Nuclear instrumentation – Constructional requirements and classification of radiometric gauges*

~~IEC Guide 104, *The preparation of safety publications and the use of basic safety publications and group safety publications*~~

ISO/IEC Guide 50, *Safety aspects – Guidelines for child safety*

ISO/IEC Guide 51:1999, *Safety aspects – Guidelines for their inclusion in standards*

ISO 306, *Plastics – Thermoplastic materials – Determination of Vicat softening temperature (VST)*

ISO 361, *Basic ionizing radiation symbol*

ISO 3746, *Acoustics – Determination of sound power levels of noise sources using sound pressure – Survey method using an enveloping measurement surface over a reflecting plane*

ISO 7000, *Graphical symbols for use on equipment – Index and synopsis*. Available from: <http://www.graphical-symbols.info/equipment>

ISO 9614-1, *Acoustics – Determination of sound power levels of noise sources using sound intensity – Part 1: Measurement at discrete points*

ISO 13857:2008, Safety of machinery – Safety distances to prevent hazard zones being reached by upper and lower limbs

### 3 Terms and definitions

For the purposes of this document, the following terms and definitions apply.

#### 3.1 Equipment and states of equipment

##### 3.1.1

###### FIXED EQUIPMENT

equipment fastened to a support, or otherwise secured in a specific location

[SOURCE: IEC 60050-826:2004, 826-16-07, modified – “electric” has been deleted.]

##### 3.1.2

###### PERMANENTLY CONNECTED EQUIPMENT

equipment that is electrically connected to a supply by means of a permanent connection which can be detached only by the use of a TOOL

##### 3.1.3

###### PORTABLE EQUIPMENT

equipment intended to be carried by hand

##### 3.1.4

###### HAND-HELD EQUIPMENT

PORTABLE EQUIPMENT intended to be supported by one hand during NORMAL USE

##### 3.1.5

###### TOOL

~~external device, including keys and coins, used to aid a person to perform a mechanical function~~

mechanical device intended to make a task easier

Note 1 to entry: See 4.3.2.14.

##### 3.1.6

###### DIRECT PLUG-IN EQUIPMENT

equipment with a MAINS plug that is attached to the equipment housing without the use of a MAINS supply cord so that the equipment is supported by the MAINS socket-outlet

#### 3.2 Parts and accessories

##### 3.2.1

###### TERMINAL

~~component provided for the connection of a device to external conductors~~

conductive part of a device, electric circuit or electric network, provided for connecting that device, electric circuit or electric network to one or more external conductors

Note 1 to entry: TERMINALS can contain one or several contacts and the term therefore includes sockets, connectors, etc.

[SOURCE: IEC 60050-151:2001, 151-12-12, modified – Note 1 to entry has been added.]

### 3.2.2

#### FUNCTIONAL EARTH TERMINAL

TERMINAL by which electrical connection is made directly to a point of a measuring or control circuit or to a screening part and which is intended to be earthed for any functional purpose other than safety

Note 1 to entry: For measuring equipment, this TERMINAL is often called the measuring earth TERMINAL.

### 3.2.3

#### PROTECTIVE CONDUCTOR TERMINAL

TERMINAL which is bonded to conductive parts of equipment for safety purposes and is intended to be connected to an external protective earthing system

### 3.2.4

#### ENCLOSURE

part providing protection of equipment against certain external influences and, in any direction, protection against direct contact

Note 1 to entry: ENCLOSURES may also provide protection against the spread of fire (see 9.3.2 c)).

### 3.2.5

#### PROTECTIVE BARRIER

##### ELECTRICALLY PROTECTIVE BARRIER

part providing protection against direct contact from any usual direction of access

Note 1 to entry: Depending on its construction, a PROTECTIVE BARRIER can be called a casing, cover, screen, door, guard, etc. A PROTECTIVE BARRIER can act alone; it is then only effective when it is in place. A PROTECTIVE BARRIER can also act in conjunction with an interlocking device with or without guard locking; in this case, protection is ensured whatever the position of the PROTECTIVE BARRIER.

[SOURCE: IEC 60050-195:1998, 195-06-15]

## 3.3 Quantities

### 3.3.1

#### RATED

##### rated value

~~quantity value assigned, generally by a manufacturer, for a specified operating condition of a component, device or equipment~~

value of a quantity used for specification purposes, established, generally by the manufacturer, for a specified set of operating conditions of a component, device, equipment, or system

[SOURCE: IEC 60050-151:2001, 151-16-08, modified to emphasize that the manufacturer sets the rated values.]

### 3.3.2

#### RATING

set of RATED values and operating conditions

[SOURCE: IEC 60050-151:2001, 151-16-11]

### 3.3.3

#### WORKING VOLTAGE

highest r.m.s. value of the a.c. or d.c. voltage across any particular insulation which can occur when the equipment is supplied at RATED voltage

Note 1 to entry: Transients and voltage fluctuations are not considered to be part of the WORKING VOLTAGE.

Note 2 to entry: Both open-circuit conditions and normal operating conditions are taken into account.

### **3.4 Tests**

#### **3.4.1**

##### **TYPE TEST**

test of one or more samples of equipment (or parts of equipment) made to a particular design, to show that the design and construction meet one or more requirements of this Technical Specification

Note 1 to entry: This is an amplification of the IEC 60050-151:2001, 151-16-16 definition to cover design as well as construction.

#### **3.4.2**

##### **ROUTINE TEST**

conformity test made on each individual item during or after manufacture

[SOURCE: IEC 60050-151:2001, 151-16-17]

### **3.5 Safety terms**

#### **3.5.1**

##### **ACCESSIBLE**

able to be touched with a standard test finger or test pin, when used as specified in 6.2

#### **3.5.2**

##### **HAZARD**

potential source of harm

#### **3.5.3**

##### **HAZARDOUS LIVE**

capable of rendering an electric shock or electric burn

#### **3.5.4**

##### **MAINS**

low-voltage electricity supply system to which the equipment concerned is designed to be connected for the purpose of powering the equipment

#### **3.5.5**

##### **MAINS CIRCUIT**

circuit which is intended to be directly connected to the MAINS for the purpose of powering the equipment

#### **3.5.6**

##### **PROTECTIVE IMPEDANCE**

component or assembly of components whose impedance, construction and reliability are suitable to provide protection against electric shock

#### **3.5.7**

##### **PROTECTIVE BONDING**

electrical connection of ACCESSIBLE conductive parts or protective screening to provide electrical continuity to the means for connection of an external protective conductor

#### **3.5.8**

##### **NORMAL USE**

operation, including stand-by, according to the instructions for use or for the obvious intended purpose

### 3.5.9

#### **NORMAL CONDITION**

condition in which all means for protection against HAZARDS are intact

### 3.5.10

#### **SINGLE FAULT CONDITION**

condition in which one means for protection against HAZARD is defective or one fault is present which could cause a HAZARD

~~Note 1 to entry: If a SINGLE FAULT CONDITION results unavoidably in one or more other fault conditions, all the failures are considered as one SINGLE FAULT CONDITION [IEC Guide 104].~~

### 3.5.11

#### **OPERATOR**

person operating equipment for its intended purpose

Note 1 to entry: Within this Technical Specification, the term "OPERATOR" indicates either an adult OPERATOR or a STUDENT OPERATOR, unless otherwise specified.

### 3.5.12

#### **RESPONSIBLE BODY**

individual or group responsible for the safe use and maintenance of equipment

### 3.5.13

#### **WET LOCATION**

location where water or another conductive liquid may be present and is likely to cause reduced human body impedance due to wetting of the contact between the human body and the equipment, or wetting of the contact between the human body and the environment

### 3.5.14

#### **REASONABLY FORESEEABLE MISUSE**

use of a product in a way not intended by the supplier, but which may result from readily predictable human behaviour

Note 1 to entry: The age of the CHILD will affect the predictability of the behaviour.

### 3.5.15

#### **RISK**

combination of the probability of occurrence of harm and the severity of that harm

### 3.5.16

#### **TOLERABLE RISK**

RISK which is accepted in a given context based on the current values of society

[SOURCE: ISO/IEC Guide 51:1999, 3.7]

### 3.5.17

#### **OVERVOLTAGE CATEGORY**

numeral defining a TRANSIENT OVERVOLTAGE condition

Note 1 to entry: See Annex K.

### 3.5.18

#### **TRANSIENT OVERVOLTAGE**

short duration overvoltage of a few milliseconds or less, oscillatory or non-oscillatory, usually highly damped

[SOURCE: IEC 60050-604, Amendment 1:1998, 604-03-13]

### 3.5.19

#### TEMPORARY OVERVOLTAGE

power frequency overvoltage of relatively long duration

[SOURCE: IEC 60050-604, Amendment 1:1998, 604-03-12]

### 3.5.20

#### CHILD (CHILDREN)

person (persons) aged at least 3 years and below 16 years

Note 1 to entry: This definition is intended for use in this Technical Specification. It does not match the definitions found in ISO/IEC Guide 50 and other documents.

### 3.5.21

#### STUDENT OPERATOR

CHILD undergoing education in an educational establishment under the supervision of the RESPONSIBLE BODY

## 3.6 Insulation

### 3.6.1

#### BASIC INSULATION

insulation of HAZARDOUS LIVE parts which provides basic protection

Note 1 to entry: BASIC INSULATION may serve also for functional purposes.

[SOURCE: IEC 60050-195:1998, 195-06-06]

### 3.6.2

#### SUPPLEMENTARY INSULATION

~~independent insulation applied in addition to BASIC INSULATION, for fault protection in order to provide protection against electric shock in the event of a failure of BASIC INSULATION~~

[SOURCE: IEC 60050-195:1998, 195-06-07, ~~modified~~]

### 3.6.3

#### DOUBLE INSULATION

insulation comprising both BASIC INSULATION and SUPPLEMENTARY INSULATION

[SOURCE: IEC 60050-195:1998, 195-06-08]

### 3.6.4

#### REINFORCED INSULATION

~~insulation which provides protection against electric shock not less than that provided by DOUBLE INSULATION~~

insulation of hazardous-live-parts which provides a degree of protection against electric shock equivalent to DOUBLE INSULATION

Note 1 to entry: REINFORCED INSULATION may be composed of several layers which cannot be tested singly as BASIC INSULATION or SUPPLEMENTARY INSULATION.

[SOURCE: IEC 60050-195:1998, 195-06-09, ~~modified~~]

### 3.6.5

#### POLLUTION

addition of foreign matter, solid, liquid or gaseous (ionized gases), that may produce a reduction of dielectric strength or surface resistivity

### 3.6.6

#### POLLUTION DEGREE

numeral indicating the level of POLLUTION that may be present in the environment



### **3.6.7**

#### **POLLUTION DEGREE 1**

no POLLUTION or only dry, non-conductive POLLUTION occurs, which has no influence

### **3.6.8**

#### **POLLUTION DEGREE 2**

only non-conductive POLLUTION occurs except that occasionally a temporary conductivity caused by condensation is expected

### **3.6.9**

#### **POLLUTION DEGREE 3**

conductive POLLUTION occurs, or dry, non-conductive POLLUTION occurs which becomes conductive due to condensation which is expected

Note 1 to entry: In such conditions, equipment is normally protected against exposure to direct sunlight, precipitation, and full wind pressure, but neither temperature nor humidity is controlled.

### **3.6.10**

#### **POLLUTION DEGREE 4**

continuous conductivity occurs due to conductive dust, rain or other wet conditions

### **3.6.11**

#### **CLEARANCE**

shortest distance in air between two conductive parts

### **3.6.12**

#### **CREEPAGE DISTANCE**

shortest distance along the surface of a solid insulating material between two conductive parts

[SOURCE: IEC 60050-151:2001, 151-15-50]

## **4 Tests**

### **4.1 General**

Tests in this Technical Specification are TYPE TESTS to be carried out on samples of equipment or parts. Their only purpose is to check that the design and construction ensure conformity with this Technical Specification. In addition, manufacturers shall perform the ROUTINE TESTS of Annex F on 100 % of equipment produced which has both HAZARDOUS LIVE parts and ACCESSIBLE conductive parts.

The equipment shall at least meet the requirements of this Technical Specification. It is permissible to exceed the requirements. If, in this Technical Specification, a lower limit is specified for a conformity value, then the equipment may demonstrate a larger value. If an upper limit is specified for a conformity value, the equipment may demonstrate a lower value.

Tests on subassemblies that meet the requirements of the relevant standards specified in this Technical Specification, and used in accordance with them, need not be repeated during TYPE TESTS of the whole equipment.

*Conformity with the requirements of this Technical Specification is checked by carrying out all applicable tests, except that a test may be omitted if examination of the equipment and design documentation demonstrates conclusively that the equipment would pass the test. Tests are carried out both under reference test conditions (see 4.3) and under fault conditions (see 4.4).*

*Where conformity statements in this Technical Specification require inspection, this may include examination of the equipment by measurement, examination of the markings on the equipment, examination of the instructions supplied with the equipment, examination of the*

*data sheets of the materials or components from which the equipment is manufactured, etc. In each case, the inspection will either demonstrate that the equipment meets the applicable requirements, or will indicate that further testing is required.*

*If, when carrying out a conformity test, there is any uncertainty about the exact value of an applied or measured quantity (for example voltage) due to the tolerance:*

- a) manufacturers should ensure that at least the specified test value is applied;*
- b) test houses should ensure that no more than the specified test value is applied.*

## **4.2 Sequence of tests**

The sequence of tests is optional unless otherwise specified. The equipment under test shall be carefully inspected after each test. If the result of a test causes doubt whether any earlier tests would have been passed if the sequence had been reversed, these earlier tests shall be repeated.

## **4.3 Reference test conditions**

### **4.3.1 Environmental conditions**

Unless otherwise specified in this Technical Specification, the following environmental conditions shall exist in the test location:

- a) a temperature of 15 °C to 35 °C;
- b) a relative humidity of not more than 75 %, but not exceeding the limits of 1.4.1 d);
- c) an air pressure of 75 kPa to 106 kPa;
- d) no hoar-frost, dew, percolating water, rain, solar radiation, etc.

### **4.3.2 State of equipment**

#### **4.3.2.1 General**

Unless otherwise specified, each test shall be carried out on the equipment assembled for NORMAL USE and under the least favourable combination of the conditions given in 4.3.2.2 to 4.3.2.13 ~~4.3.2.14~~.

**NOTE**—In case of doubt, tests ~~should~~ shall be performed in more than one combination of conditions.

If dimensions or mass make it unsuitable to carry out particular tests on completely assembled equipment, tests on sub-assemblies are allowed, provided it is verified that the assembled equipment will meet the requirements of this Technical Specification.

#### **4.3.2.2 Position of equipment**

The equipment shall be in any position of NORMAL USE and with any ventilation unimpeded. Equipment intended to be built into a wall, recess, cabinet, etc., shall be installed as specified in the manufacturer's instructions.

#### **4.3.2.3 Accessories**

Accessories and OPERATOR-interchangeable parts available from, or recommended by, the manufacturer for use with the equipment under test shall be either connected or not connected.

#### **4.3.2.4 Covers and removable parts**

Covers or parts which can be removed without using a TOOL shall be removed or not removed.

#### 4.3.2.5 MAINS supply

The following requirements apply.

- a) The supply voltage shall be between 90 % and 110 % of any RATED supply voltage for which the equipment can be set or, if the equipment is RATED for a greater fluctuation, at any supply voltage within the fluctuation range.
- b) The frequency shall be any RATED frequency.
- c) Equipment for both a.c. and d.c. shall be connected to an a.c. or d.c. supply.
- d) Equipment for single-phase a.c. supply shall be connected both with normal and reverse polarity.
- e) If the means of connection permits reversal, battery-operated and d.c. equipment shall be connected with both reverse and normal polarity.

#### 4.3.2.6 Input and output voltages

Input and output voltages, including floating voltages but excluding the MAINS supply voltage, shall be set to any voltage within the RATED voltage range.

#### 4.3.2.7 Earth TERMINALS

PROTECTIVE CONDUCTOR TERMINALS, if any, shall be connected to earth.

FUNCTIONAL EARTH TERMINALS shall be connected or not connected to earth.

#### 4.3.2.8 Controls

Controls which an OPERATOR can adjust without the use of a TOOL shall be set to any position, ~~except that:~~

- ~~a) MAINS selection devices shall be set to the correct value;~~
- ~~b) combinations of settings shall not be made if they are prohibited by the manufacturer's marking on the equipment.~~

#### 4.3.2.9 Connections

The equipment shall be connected for NORMAL USE, or not connected.

#### 4.3.2.10 Load on motors

Load conditions of motor-driven parts of equipment shall be in accordance with the NORMAL USE.

#### 4.3.2.11 Output

For equipment giving an electrical output:

- a) the equipment shall be operated in such a way as to provide the RATED output power to the RATED load;
- b) the RATED load impedance of any output shall be connected or not connected.

#### 4.3.2.12 Duty cycle

Equipment for short-term or intermittent operation shall be operated for the longest RATED period and shall have the shortest RATED recovery period consistent with the manufacturer's instructions.

Equipment for short-term or intermittent operation that develops significant heat during the startup phase, and that relies on continued operation to dissipate that heat, shall also be operated for the shortest RATED period followed by the shortest RATED recovery period.

#### 4.3.2.13 Loading and filling

Equipment intended to be loaded with a specific material in NORMAL USE shall be loaded with the least favourable quantity of the materials specified in the instructions for use, including not loaded (empty) if the instructions for use permit this in NORMAL USE.

NOTE—If the specified material could cause a HAZARD during test, another material may be used provided that it can be shown that the result of the test is not affected.

#### 4.3.2.14 Improvised TOOLS

All parts or subassemblies of the equipment that may be removed, installed, opened, closed, modified, adjusted, or reset using a readily-available device which could be used as if it were a TOOL shall be or not be removed, installed, opened, closed, modified, adjusted, or reset.

Consideration shall be given to devices that may be readily available to CHILDREN, including coins, keys, pocket knives, and paper clips.

### 4.4 Testing in SINGLE FAULT CONDITION

#### 4.4.1 General

The following requirements apply.

- a) Examination of the equipment and its circuit diagram will generally show the fault conditions which are liable to result in HAZARDS and which, therefore, shall be applied.
- b) Fault tests shall be made as specified for checking conformity, unless it can be demonstrated that no HAZARD could arise from a particular fault condition.
- c) The equipment shall be operated under the least favourable combination of reference test conditions (see 4.3). These combinations may be different for different faults and they shall be recorded for each test.

#### 4.4.2 Application of fault conditions

##### 4.4.2.1 General

Fault conditions shall include those specified in 4.4.2.2 to 4.4.2.14. They shall be applied only one at a time and shall be applied in turn in any convenient order. Multiple simultaneous faults shall not be applied unless they are a consequence of an applied fault.

NOTE—For example, fans may be stopped one fan at a time unless they share a common power or control source. In that case, the common fans ~~should~~ shall be stopped simultaneously by interrupting the power or control source.

After each application of a fault condition, the equipment or part shall pass the applicable tests of 4.4.4.

##### 4.4.2.2 PROTECTIVE IMPEDANCE

The following requirements apply.

- a) If a PROTECTIVE IMPEDANCE is formed by a combination of components, each component shall be short-circuited or disconnected, whichever is less favourable.
- b) If a PROTECTIVE IMPEDANCE is formed by the combination of BASIC INSULATION and a current- or voltage-limiting device, both the BASIC INSULATION and the current- or voltage-limiting device shall be subjected to single faults, applied one at a time. BASIC INSULATION

shall be bridged and the current- or voltage-limiting device shall be short-circuited or disconnected, whichever is less favourable.

- c) If a PROTECTIVE IMPEDANCE is formed with a single component that meets the requirements of 6.5.4, it need not be short-circuited or disconnected.

#### **4.4.2.3 Protective conductor**

The protective conductor shall be interrupted, except for PERMANENTLY CONNECTED EQUIPMENT and equipment utilizing a connector meeting the requirements of IEC 60309-1.

#### **4.4.2.4 Equipment or parts for short-term or intermittent operation**

These shall be operated continuously if continuous operation could occur in a SINGLE FAULT CONDITION. Individual parts may include motors, relays, other electromagnetic devices and heaters.

#### **4.4.2.5 Motors**

Motors shall be stopped while fully energized or prevented from starting, whichever is less favourable.

One supply phase of any multi-phase motor shall be interrupted while the motor is operating at its intended full load.

#### **4.4.2.6 Capacitors**

Capacitors (except for self-healing capacitors) in the auxiliary winding circuits of motors shall be short-circuited.

#### **4.4.2.7 MAINS transformers**

##### **4.4.2.7.1 General**

The secondary windings of MAINS transformers shall be short-circuited as specified in 4.4.2.7.2, and overloaded as specified in 4.4.2.7.3.

A transformer damaged during one test may be repaired or replaced before the next test.

Tests for MAINS transformers tested as separate components are specified in 14.6.

##### **4.4.2.7.2 Short circuit**

Each untapped output winding, and each section of a tapped output winding, which is loaded in NORMAL USE, shall be tested in turn, one at a time, to simulate short circuits in the load. Overcurrent protection devices remain fitted during the test. All other windings are loaded or not loaded, whichever load condition of NORMAL USE is less favourable.

##### **4.4.2.7.3 Overload**

Each untapped output winding, and each section of a tapped output winding, is overloaded in turn one at a time. The other windings are loaded or not loaded, whichever load condition of NORMAL USE is less favourable. If any overloads arise from testing in the fault conditions of 4.4, secondary windings shall be subjected to those overloads.

Overloading is carried out by connecting a variable resistor across the winding. The resistor is adjusted as quickly as possible and readjusted, if necessary, after 1 min to maintain the applicable overload. No further readjustments are then permitted.

If overcurrent protection is provided by a current-breaking device, the overload test current is the maximum current which the overcurrent protection device is just capable of passing for 1 h. Before the test, the device is replaced by a link with negligible impedance. If this value cannot be derived from the specification, it is to be established by test.

For equipment in which the output voltage is designed to collapse when a specified overload current is reached, the overload is slowly increased to a point just before the point which causes the output voltage to collapse.

In all other cases, the loading is the maximum power output obtainable from the transformer.

Transformers with overtemperature protection which meets the requirements of 14.3 during the short-circuit test of 4.4.2.7.2 need not be subjected to overload tests.

#### **4.4.2.8 Outputs**

Outputs shall be short-circuited one at a time.

#### **4.4.2.9 Equipment for more than one supply**

Equipment which is designed to be operated from more than one type of supply shall be simultaneously connected to these supplies, unless this is prevented by the construction.

#### **4.4.2.10 Cooling**

Equipment cooling shall be restricted as follows, one fault at a time:

- a) air-holes with filters shall be closed;
- b) forced cooling by motor-driven fans shall be stopped;
- c) cooling by circulation of water or other coolant shall be stopped;
- d) loss of cooling liquid shall be simulated.

#### **4.4.2.11 Heating devices**

In equipment incorporating heating devices, the following faults shall be applied one at a time:

- a) timers which limit the heating period shall be overridden to energize the heating circuit continuously;
- b) temperature controllers, except for overtemperature protection devices meeting the requirements of 14.3, shall be overridden to energize the heating circuit continuously.

#### **4.4.2.12 Insulation between circuits and parts**

Insulation between circuits and parts which is below the level specified for BASIC INSULATION shall be bridged to check against the spread of fire if the method of 9.1 a) is used.

#### **4.4.2.13 Interlocks**

Each part of an interlock system for the protection of the OPERATOR shall be short-circuited or open-circuited in turn if the system prevents access to HAZARDS when a cover, etc. is removed without the use of a TOOL.

#### **4.4.2.14 Voltage selectors**

Voltage selectors which an OPERATOR can set for different RATED supply voltages shall be set for each possible setting with the equipment connected to each of its RATED supply circuits.

#### **4.4.3 Duration of tests**

##### **4.4.3.1 General**

The equipment shall be operated until further change as a result of the applied fault is unlikely. Each test is normally limited to 1 h since a secondary fault arising from a SINGLE FAULT CONDITION will usually manifest itself within that time. If there is an indication that a HAZARD of electric shock, spread of fire or injury to persons may eventually occur, the test shall be continued for 4 h unless one of these HAZARDS arises before then.

##### **4.4.3.2 Current limiting devices**

If a device which interrupts or limits the current during operation is included to limit the temperature of parts which can easily be touched, the maximum temperature attained by those parts shall be measured, whether the device operates or not.

##### **4.4.3.3 Fuses**

If a fault is terminated by the opening of a fuse and if the fuse does not operate within approximately 1 s, the current through the fuse under the relevant fault condition shall be measured. The pre-arcing time/current characteristics of the fuse shall be evaluated to find out whether the minimum operating current is reached and what is the maximum time before the fuse operates. The current through the fuse may vary as a function of time.

If the minimum operating current of the fuse is not reached in the test, the equipment shall be operated for a period corresponding to the maximum fusing time or continuously for the duration specified in 4.4.3.1, with the fuse replaced with a short-circuit.

#### **4.4.4 Conformity after application of fault conditions**

##### **4.4.4.1 General**

*Conformity with requirements for protection against electric shock after the application of single faults is checked as follows:*

- a) *by making the measurements of 6.3.2 to check that no ACCESSIBLE conductive parts have become HAZARDOUS LIVE;*
- b) *by performing a voltage test on DOUBLE INSULATION or REINFORCED INSULATION to check that the protection is still at least at the level of BASIC INSULATION. The voltage tests are made as specified in 6.7 and 6.8 (without humidity preconditioning) with the test voltage for BASIC INSULATION;*
- c) *by measuring the temperature of transformer windings if the protection against electrical HAZARDS is achieved by DOUBLE INSULATION or REINFORCED INSULATION within the transformer. The temperatures of Table 20 shall not be exceeded.*

##### **4.4.4.2 Temperature**

*Conformity with requirements for temperature protection is checked by determining the temperature of the outer surface of the ENCLOSURE and of parts which can easily be touched (see Clause 10).*

##### **4.4.4.3 Spread of fire**

*Conformity with requirements for protection against the spread of fire is checked by placing the equipment on white tissue-paper covering a softwood surface and covering the equipment with cheesecloth. No molten metal, burning insulation, flaming particles, etc. shall fall on the surface on which the equipment stands and there shall be no charring, glowing, or flaming of the tissue paper or cheesecloth. Melting of insulation material shall be ignored if no HAZARD could arise.*



#### 4.4.4.4 Other HAZARDS

*Conformity with other requirements for protection against HAZARDS is checked as specified in Clauses 7 to 16.*

## 5 Marking and documentation

### 5.1 Marking

#### 5.1.1 General

Equipment shall bear markings as specified in 5.1.2 to 5.2. Except for marking of internal parts, these markings shall be visible from the exterior, or be visible after removing a cover or opening a door without the aid of a TOOL, if the cover or door is intended to be removed or opened by an OPERATOR. Markings applying to the equipment as a whole shall not be put on parts which can be removed by an OPERATOR without the use of a TOOL.

For rack- or panel-mounted equipment, markings are permitted to be on a surface that becomes visible after removal of the equipment from the rack or panel.

Letter symbols for quantities and units shall be as specified in IEC 60027-1. Graphic symbols shall be in accordance with Table 1 if applicable. Except for symbol 18, there are no colour requirements for symbols. Graphic symbols shall be explained in the documentation.

NOTE 1—IEC or ISO symbols should be used if available.

NOTE 2—Markings should not be on the bottom of the equipment, except on HAND-HELD EQUIPMENT or where space is limited.

*Conformity is checked by inspection.*

#### 5.1.2 Identification

The equipment shall, as a minimum, be marked with:

- a) the name or trade mark of the manufacturer or supplier;
- b) a model number, name or other means to identify the equipment. If equipment bearing the same distinctive designation (model number) is manufactured at more than one location, equipment from each manufacturing location shall be marked so that the location can be identified.

NOTE—The marking of factory location may be in code and does not need to be on the equipment exterior.

- c) symbol 18 of Table 1, including the age limit, for example: '≥ 11'.

*Conformity is checked by inspection.*

#### 5.1.3 MAINS supply

The equipment shall be marked with the following information.

- a) Nature of supply:
  - 1) a.c.: RATED MAINS frequency or range of frequencies;
  - 2) d.c.: symbol 1 of Table 1.

NOTE For information purposes it is, in some cases, useful to mark

- equipment intended for a.c. with symbol 2 of Table 1;
- equipment suitable for both a.c. and d.c. with symbol 3 of Table 1;
- equipment for three-phase supply with symbol 4 of Table 1.

- b) The RATED supply voltage(s) or the RATED range of supply voltages.



















~~NOTE 2~~ RATED voltage fluctuations may also be marked.

- c) The maximum RATED power in watts (active power) or volt-amperes (apparent power), or the maximum RATED input current, with all accessories or plug-in modules connected. If the equipment can be used on more than one voltage range, separate values shall be marked for each voltage range unless the maximum and minimum values do not differ by more than 20 % of the mean value. The marked value shall not be less than 90 % of the maximum value.
- d) Equipment which an OPERATOR can set for different RATED supply voltages shall be provided with means for the indication of the voltage for which the equipment is set. For PORTABLE EQUIPMENT the indication shall be visible from the exterior. If the equipment is so constructed that the supply voltage setting can be altered without the use of a TOOL, the action of changing the setting shall also change the indication.
- e) Accessory MAINS socket-outlets accepting standard MAINS plugs shall be marked with the voltage if it is different from the MAINS supply voltage. If the outlet is for use only with specific equipment, it shall be marked to identify the equipment for which it is intended. If not, the maximum RATED current or power shall be marked, or symbol 14 of Table 1 placed beside the outlet with the full details included in the documentation.

*Conformity is checked by inspection and by measurement of power or input current to check the marking of 5.1.3 c). The measurement is made with the equipment in the condition of maximum power consumption, but to exclude any initial inrush current it is not made until the current has stabilized (usually after 1 min). Transients are ignored.*

**Table 1 – Symbols**

Number	Symbol	Reference	Description
1		IEC 60417-5031 (2002-10)	Direct current
2		IEC 60417-5032 (2002-10)	Alternating current
3		IEC 60417-5033 (2002-10)	Both direct and alternating current
4		IEC 60417-5032-1 (2002-10)	Three-phase alternating current
5		IEC 60417-5017 (2006-08)	Earth; ground <del>TERMINAL</del>
6		IEC 60417-5019 (2006-08)	<u>Protective earth; protective ground</u> <del>PROTECTIVE CONDUCTOR TERMINAL</del>
7		IEC 60417-5020 (2002-10)	Frame or chassis <del>TERMINAL</del>
8			Not used
9		IEC 60417-5007 (2002-10)	"On" (power)
10		IEC 60417-5008 (2002-10)	"Off" (power)
11		IEC 60417-5172 (2003-02)	<u>(Class II Equipment)</u> Equipment protected throughout by DOUBLE INSULATION or REINFORCED INSULATION

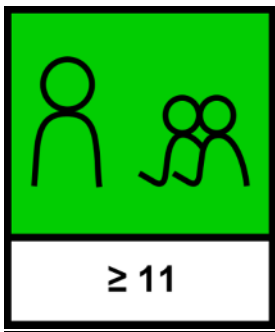
Number	Symbol	Reference	Description
12		IEC 60417-6042 (2010-11)	Caution, RISK of electric shock
13		IEC 60417-5041 (2002-10)	Caution, hot surface
14		ISO 7000-0434B (2004-01)	Caution <sup>a</sup>
15		IEC 60417-5268 (2002-10)	"IN" position of a bi-stable push control
16		IEC 60417-5269 (2002-10)	"OUT" position of a bi-stable push control
17		ISO 361:1975	Ionizing radiation
<u>18</u>			<u>intended for use in educational establishments by STUDENT OPERATORS at least 11 years old under supervision of the RESPONSIBLE BODY</u> <sup>b, c, d</sup>
<p><sup>a</sup> See 5.4.1 which requires manufacturers to state that documentation must be consulted in all cases where this symbol is marked.</p> <p><sup>b</sup> <u>The green background colour is required, as specified in ISO 3864-1.</u></p> <p><sup>c</sup> <u>The symbol includes IEC symbols 60417-5187 (2002-10) and 60417-5189 (2002-10).</u></p> <p><sup>d</sup> <u>The number 11 is an example: other numbers can be marked for other ages.</u></p>			

#### 5.1.4 Fuses

For any fuse which may be replaced by an OPERATOR, there shall be a marking beside the fuseholder, which will enable the OPERATOR to identify the correct replacement fuse (see 5.4.5).

*Conformity is checked by inspection.*

#### 5.1.5 TERMINALS, connections and operating devices

##### 5.1.5.1 General

If necessary for safety, an indication shall be given of the purpose of TERMINALS, connectors, controls, and indicators, including any connections for fluids such as gas, water and drainage. Where there is insufficient space, symbol 14 of Table 1 may be used.

NOTE 1 For additional information, see IEC 60445 and IEC 60447.

NOTE 2—Individual pins of multi-pin connectors need not be marked.

Push-buttons and actuators of emergency stop devices, and indicators used only to indicate a warning of danger or the need for urgent action, shall be coloured red and coded as specified

in IEC 60073. If the meaning of colour relates to the safety of persons or the environment, supplementary means of coding shall be provided (see IEC 60073).

NOTE 2 National authorities can require that equipment used in certain environments meet the man-machine interface requirements pertinent to that environment.

*Conformity is checked by inspection.*

### 5.1.5.2 TERMINALS

TERMINALS for connection to the MAINS supply shall be identifiable.

The following TERMINALS shall be marked as follows:

- a) FUNCTIONAL EARTH TERMINALS with symbol 5 of Table 1;
- b) PROTECTIVE CONDUCTOR TERMINALS with symbol 6 of Table 1, except when the PROTECTIVE CONDUCTOR TERMINAL is part of an approved MAINS appliance inlet. The symbol shall be placed on the TERMINAL or close to it;
- c) TERMINALS of control circuits which are permitted by 6.6.3 to be connected to ACCESSIBLE conductive parts, with symbol 7 of Table 1 unless connection is self-evident;

NOTE 1 This symbol may also be considered as a warning symbol in that it indicates that a HAZARDOUS LIVE voltage must not be connected to the TERMINAL. The symbol should also be used if it is likely that an OPERATOR could make such a connection inadvertently.

- d) TERMINALS supplied from the interior of the equipment and which are HAZARDOUS LIVE, with the voltage, current, charge or energy value or range, or with symbol 14 of Table 1. This requirement does not apply to MAINS supply outlets where a standard MAINS socket outlet is used.

NOTE 2 In some countries, STUDENT OPERATORS might not be permitted access to TERMINALS which are HAZARDOUS LIVE.

*Conformity is checked by inspection.*

### 5.1.6 Switches and circuit-breakers

If the power supply switch or circuit-breaker is used as the disconnecting device, the off-position shall be clearly marked.

NOTE—It is recommended that the on-position also be marked.

Symbols 9 and 10 of Table 1 can, in some cases, also be suitable as the device identification (see 6.11.3.1 c)). A lamp alone is not considered to be a satisfactory marking.

If a push-button switch is used as the power supply switch, symbols 9 and 15 of Table 1 may be used to indicate the on-position, or symbols 10 and 16 to indicate the off-position, with the pair of symbols (9 and 15, or 10 and 16) close together.

*Conformity is checked by inspection.*

### 5.1.7 Equipment protected by DOUBLE INSULATION or REINFORCED INSULATION

Equipment which is only partially protected by DOUBLE INSULATION or REINFORCED INSULATION shall not be marked with symbol 11 of Table 1.

NOTE—Equipment protected throughout by DOUBLE INSULATION or REINFORCED INSULATION may be marked with symbol 11 of Table 1.

*Conformity is checked by inspection.*

### 5.1.8 Field-wiring TERMINAL boxes

If the temperature of the TERMINALS or the ENCLOSURE of a field-wiring TERMINAL box or compartment exceeds 60 °C in NORMAL CONDITION at an ambient temperature of 40 °C, or at the maximum RATED ambient temperature if higher, there shall be a marking to warn the installer to consult the installation instructions before determining the temperature RATING of the cable to be connected to the TERMINALS. The marking shall be visible before and during connection, or be beside the TERMINALS. Symbol 14 is an acceptable marking.

*Conformity, in case of doubt, is checked by measurement as specified in 10.3 a) and, if applicable, by inspection of markings.*

### 5.2 Warning markings

Warning markings specified in 5.1.5.2 c), 6.1.2 b), 6.6.2, 7.3.2 b) 3), 7.3.5.2, 7.4, 10.1 and 13.2.2 shall meet the following requirements.

Warning markings shall be visible when the equipment is ready for NORMAL USE. If a warning applies to a particular part of the equipment, the marking shall be placed on or near that part.

The size of warning markings shall be as follows:

- a) symbols shall be at least 2,75 mm high. Text shall be at least 1,5 mm high and contrast in colour with the background;
- b) symbols or text moulded, stamped or engraved in a material shall be at least 2,0 mm high. If not contrasting in colour, they shall have a depth or raised height of at least 0,5 mm.

If it is necessary for the RESPONSIBLE BODY or OPERATOR to refer to the documentation to preserve the protection afforded by the equipment, the equipment shall be marked with symbol 14 of Table 1. Symbol 14 is not required to be used if other symbols which address the safety aspects are used and explained in the documentation.

If the instructions for use state that an OPERATOR is permitted to gain access, using a TOOL, to a part which in NORMAL USE may be HAZARDOUS LIVE, there shall be a warning marking which states that the equipment must be isolated or disconnected from the HAZARDOUS LIVE voltage before access.

NOTE In some countries, STUDENT OPERATORS might not be allowed access to HAZARDOUS LIVE parts, except if they are undergoing technical training, when they might have the same access as an older OPERATOR.

*Conformity is checked by inspection.*

### 5.3 Durability of markings

Required markings shall remain clear and legible under conditions of NORMAL USE and shall resist the effects of the cleaning agents specified by the manufacturer.

*Conformity is checked by performing the following test for durability of markings on the outside of the equipment. The markings are rubbed by hand, without undue pressure, for 30 s with a cloth soaked with each specified cleaning agent (or, if not specified, with 70 % isopropyl alcohol).*

*After the above treatment the markings shall be clearly legible and adhesive labels shall not have worked loose or become curled at the edges.*

## 5.4 Documentation

### 5.4.1 General

The following documentation necessary for safety purposes, as needed by the OPERATOR or the RESPONSIBLE BODY, shall be provided with the equipment. Safety documentation for service personnel authorized by the manufacturer shall be made available to such personnel:

- a) intended use of the equipment, including a statement of the minimum age for which the equipment is intended, for example 'This equipment is suitable for use in educational establishments by students at least 11 years old when supervised', and any additional information regarding suitability for use by STUDENT OPERATORS in education with special needs;
- b) technical specification;
- c) name and address of the manufacturer or supplier from whom technical assistance may be obtained;
- d) the information specified in 5.4.2 to 5.4.6;
- e) information about how to mitigate RISKS remaining after a RISK assessment has been performed (see Clause 17);
- f) for equipment which for safety reasons requires specific accessories (for example probe assemblies) with specific characteristics, the documentation shall indicate that only accessories which meet the manufacturer's specifications shall be used;
- g) if a HAZARD could be caused by an incorrect reading when measuring, indicating or detecting harmful or corrosive substances, or HAZARDOUS LIVE electrical quantities, the instructions shall provide guidance on how to determine that the equipment is functioning correctly;
- h) instructions for lifting and carrying (see 7.5);
- i) a statement that cleaning or decontamination must be done only under the supervision of the RESPONSIBLE BODY.

Warning symbols and warning statements that are marked on the equipment shall be explained in the documentation. In particular, the documentation shall include a statement that it must be consulted in all cases where symbol 14 of Table 1 is marked, in order to find out the nature of the potential HAZARDS and any actions which have to be taken to avoid them.

NOTE Markings and text on equipment are considered equivalent to the documentation.

NOTE 2—If NORMAL USE involves the handling of harmful or corrosive substances, instruction should be given on correct use and safety provisions. If any harmful or corrosive substance is specified or supplied by the equipment manufacturer, the necessary information on its constituents and the correct disposal procedure should also be given.

Documentation may be provided on printed or electronic media, however printed information is required for all information necessary for safety that might not be available in electronic form at the time it is needed. The documentation shall be delivered with the equipment. Consideration shall be given to the ability of the RESPONSIBLE BODY to read the media.

*Conformity is checked by inspection.*

### 5.4.2 Equipment RATINGS

Documentation shall include the following:

- a) the supply voltage or voltage range, frequency or frequency range, and power or current RATING;
- b) a description of all input and output connections as required by 6.6.1 a);
- c) the RATING of the insulation of external circuits as required by 6.6.1 b);

- d) a statement of the range of environmental conditions for which the equipment is designed (see 1.4);
- e) a statement of the degree of ingress protection (IP), if the equipment is RATED according to IEC 60529;
- f) for equipment with an impact RATING less than 5 J, the information specified in 8.1 d).

*Conformity is checked by inspection.*

### **5.4.3 Equipment installation**

The documentation shall include installation and specific commissioning instructions and, if necessary for safety, warnings against HAZARDS which could arise during installation or commissioning of the equipment. Such information includes, if applicable:

- a) assembly, location and mounting requirements;
- b) instructions for protective earthing;
- c) connections to the supply;
- d) for PERMANENTLY CONNECTED EQUIPMENT:
  - 1) supply wiring requirements;
  - 2) requirements for any external switch or circuit-breaker (see 6.11.3.1) and external overcurrent protection devices (see 9.6.2) and a recommendation that the switch or circuit-breaker be near the equipment;
- e) ventilation requirements;
- f) requirements for special services, for example, air, cooling liquid;
- g) instructions relating to sound level (see 12.5.1);
- h) instructions that installation shall only be done under the supervision of the RESPONSIBLE BODY.

**NOTE**—It is recommended to add a statement in the documentation for the installation that the safety of any system incorporating the equipment is the responsibility of the assembler of the system.

*Conformity is checked by inspection.*

### **5.4.4 Equipment operation**

Instructions for use shall include, if applicable:

- a) identification and description of operating controls and their use in all operating modes;
- b) instructions not to position the equipment so that it is difficult to operate the disconnecting device;
- c) instructions for interconnection to accessories and other equipment, including indication of suitable accessories, detachable parts and any special materials;
- d) specifications of limits for intermittent operation;
- e) explanations of symbols related to safety which are used on the equipment;
- f) instructions for replacement of consumable materials;
- g) instructions for cleaning and decontamination;
- h) a statement listing potentially poisonous or injurious substances that can be liberated from the equipment, and possible quantities;
- i) detailed instructions about RISK reduction procedures relating to flammable liquids (see 9.5 c));
- j) details of methods of reducing the RISKS of burns from surfaces permitted to exceed the temperature limits of 10.1;

k) a statement that, to protect against eye injuries, laser sources RATED Class 2 of IEC 60825-1 or above should be clamped in place before being used.

The instructions shall include recommendations on who should be allowed to carry out the tasks documented in a) to k), with any actions to be taken and instructions to be given by the RESPONSIBLE BODY before the equipment is subsequently used by STUDENT OPERATORS.

If equipment ~~conforming to~~ within the scope of IEC 60950 is used with equipment ~~conforming to~~ within the scope of this Technical Specification, and if there is a HAZARD due to moisture or liquids, the instructions for use shall specify any additional precautions necessary.

There shall be a statement in the instructions that, if the equipment is used in a manner not specified by the manufacturer, the protection provided by the equipment may be impaired.

*Conformity is checked by inspection.*

#### **5.4.5 Equipment maintenance and service**

Instructions shall be provided to the RESPONSIBLE BODY in sufficient detail to permit safe maintenance and inspection of the equipment, and to ensure continued safety of the equipment after the maintenance and inspection procedure.

If applicable, manufacturer's documentation shall instruct against replacing detachable MAINS supply cords by inadequately RATED cords.

For equipment using replaceable batteries, the specific battery type shall be stated.

The manufacturer shall specify any parts which are required to be examined or supplied only by the manufacturer or his agent.

The RATING and characteristics of replaceable fuses shall be stated.

Instructions on the following subjects shall be provided for service personnel, as necessary to permit safe servicing and continued safety of the equipment after servicing if the equipment is suitable to be serviced:

- a) product-specific RISKS that may affect the service personnel;
- b) protective measures for these RISKS;
- c) verification of the safe state of the equipment after repair.

The manufacturer's instructions shall state that fuses must not be changed by a STUDENT OPERATOR.

**NOTE**—Instructions for service personnel do not need to be supplied to the RESPONSIBLE BODY, but should be made available to service personnel.

*Conformity is checked by inspection.*

#### **5.4.6 Integration into systems or effects resulting from special conditions**

Aspects resulting from integration into systems or effects resulting from special ambient or application conditions shall be described in the documentation.

*Conformity is checked by inspection of the documentation.*



## 6 Protection against electric shock

### 6.1 General

#### 6.1.1 Requirements

Protection against electric shock shall be maintained in NORMAL CONDITION and SINGLE FAULT CONDITION (see 6.4 and 6.5). ACCESSIBLE parts (see 6.2) shall not be HAZARDOUS LIVE (see 6.3). Voltage, current, charge or energy between an ACCESSIBLE part and earth, or between any two ACCESSIBLE parts on the same piece of equipment within a distance of 1,8 m (over a surface or through air), shall not exceed the levels of 6.3.1 in NORMAL CONDITION nor of 6.3.2 in SINGLE FAULT CONDITION.

*Conformity is checked by the determination of ACCESSIBLE parts as specified in 6.2 and by the measurements of 6.3 to establish that the levels of 6.3.1 and 6.3.2 are not exceeded, followed by the tests of 6.4 to 6.11.*

#### 6.1.2 Exceptions

If it is not feasible for operating reasons to prevent the following parts being both ACCESSIBLE and HAZARDOUS LIVE, they are permitted to be ACCESSIBLE to an OPERATOR during NORMAL USE while they are HAZARDOUS LIVE:

- a) parts of lamps and lamp sockets after lamp removal;
- b) parts intended to be replaced by an OPERATOR (for example, batteries) and which may be HAZARDOUS LIVE during the replacement or other OPERATOR action, but only if they are ACCESSIBLE only by means of a TOOL and have a warning marking (see 5.2);

If any of the parts in a) and b) receives a charge from an internal capacitor, they shall not be HAZARDOUS LIVE 10 s after interruption of the supply.

NOTE In some countries, some STUDENT OPERATORS might not be permitted to have access to HAZARDOUS LIVE parts.

*If a charge is received from an internal capacitor, conformity is checked by the measurements of 6.3 to establish that the levels of 6.3.1 c) are not exceeded.*

### 6.2 Determination of ACCESSIBLE parts

#### 6.2.1 General

*Unless obvious, determination of whether a part is ACCESSIBLE is made as specified in 6.2.2 to ~~6.2.4~~ 6.2.5 in all positions of NORMAL USE. Test fingers (see Annex B) and pins are applied without force unless a force is specified. Parts are considered to be ACCESSIBLE if they can be touched with any part of a test finger or test pin, or if they could be touched in the absence of a covering which is not considered to provide suitable insulation (see 6.9.1).*

*If, in NORMAL USE, an OPERATOR is intended to perform any actions (with or without a TOOL) that could increase the accessibility of parts, such actions are taken before performing the examinations of 6.2.2 to ~~6.2.4~~ 6.2.5.*

NOTE Examples of such actions include:

- a) removing covers;
- b) opening doors;
- c) adjusting controls;
- d) replacing consumable material;
- e) removing parts.



Rack-mounted and panel-mounted equipment is installed as specified in the manufacturer's instructions before making the examinations of 6.2.2 to ~~6.2.4~~ 6.2.5. For such equipment, the OPERATOR is assumed to be in front of the panel.

## 6.2.2 Examination

The jointed test finger (see Figure B.23) is applied in every possible position. If a part could become ACCESSIBLE by applying a force, the rigid test finger (see Figure B.1) is applied with a force of 10 N. The force is exerted by the tip of the test finger so as to avoid wedge and lever action. The test is applied to all outer surfaces, including the bottom. However, on equipment accepting plug-in modules the tip of the jointed test finger is inserted only to a depth of 180 mm from the opening in the equipment.

The test finger is likewise applied to all openings in the ENCLOSURE, including holes and TERMINALS. In these cases, the ACCESSIBLE parts of the ENCLOSURE are considered to include any part of the test finger which can be inserted into the hole or TERMINAL (see Figure 1).

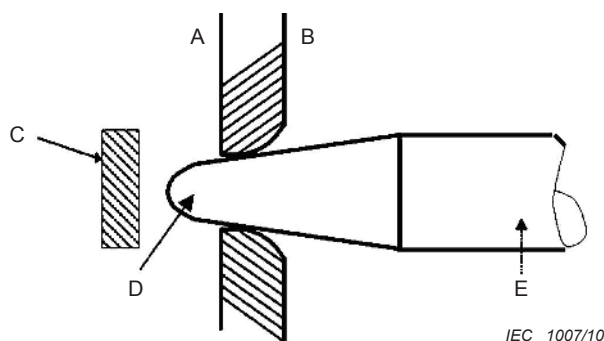

### Key

- A inside of equipment
- B outside of equipment
- C HAZARDOUS LIVE part
- D tip of test finger is considered to be ACCESSIBLE
- E test finger

Figure 1 – Measurements through openings in ENCLOSURES

## 6.2.3 ~~Not used~~ Openings above parts that are HAZARDOUS LIVE

~~A metal test pin 100 mm long and 4 mm in diameter is inserted into any openings above parts which are HAZARDOUS LIVE. The test pin is suspended freely and allowed to penetrate up to 100 mm.~~

~~The additional safety measures of 6.5.1 for protection in SINGLE FAULT CONDITION are not required solely because a part is ACCESSIBLE only by this test.~~

NOTE ~~This exception is permitted because the insertion of an object similar to this test pin is considered to be a SINGLE FAULT CONDITION and one means of protection is sufficient.~~

~~This test is not applied to TERMINALS.~~

## 6.2.4 ~~Not used~~ Openings for pre-set controls

~~A metal test pin 3 mm in diameter is inserted through holes intended to give access to pre-set controls which require the use of a screwdriver or other TOOL. The test pin is applied in every possible direction through the hole. Penetration shall not exceed three times the distance from the ENCLOSURE surface to the control shaft or 100 mm, whichever is smaller.~~

### **6.2.5 Additional determination for all openings except TERMINALS**

A metal test pin, 100 mm long and 1 mm in diameter, is inserted through all holes and gaps that might allow it to touch HAZARDOUS LIVE parts, except that it is not inserted into holes in the bottom of equipment whose size or weight make it unlikely that such a pin could be inserted into any such hole while the equipment is energised, or into TERMINALS.

NOTE This pin simulates an opened-out paper clip.

## **6.3 Limit values for ACCESSIBLE parts**

### **6.3.1 Levels in NORMAL CONDITION**

Voltages above the levels of a) are deemed to be HAZARDOUS LIVE if any of the levels of b) or c) are exceeded at the same time.

- a) The a.c. voltage levels are 33 V r.m.s., 46,7 V peak and the d.c. voltage level is 70 V. For equipment intended for use in WET LOCATIONS, the a.c. voltage levels are 16 V r.m.s., 22,6 V peak and the d.c. voltage level is 35 V.
- b) The current levels are:
  - 1) 0,5 mA r.m.s. for sinusoidal waveforms, 0,7 mA peak for non-sinusoidal waveforms or mixed frequencies, or 2 mA d.c., when measured with the measuring circuit of Figure A.1. If the frequency does not exceed 100 Hz, the measuring circuit of Figure A.2 can be used. The measuring circuit of Figure A.4 is used for equipment intended for use in WET LOCATIONS.
  - 2) 70 mA r.m.s. when measured with the measuring circuit of Figure A.3. This relates to possible burns at higher frequencies.
- c) The levels of capacitive charge or energy are:
  - 1) 45  $\mu$ C charge for voltages up to 15 kV peak or d.c.; line A of Figure 3 shows the capacitance versus voltage where the charge is 45  $\mu$ C.
  - 2) 350 mJ stored energy for voltages above 15 kV peak or d.c.

### **6.3.2 Levels in SINGLE FAULT CONDITION**

Voltages above the levels of a) are deemed to be HAZARDOUS LIVE if any of the levels of b) or c) are exceeded at the same time.

- a) The a.c. voltage levels are 55 V r.m.s., 78 V peak and the d.c. voltage level is 140 V. For equipment intended for use in WET LOCATIONS, the a.c. voltage levels are 33 V r.m.s., 46,7 V peak and the d.c. voltage level is 70 V. For voltages of short duration, the duration versus voltage levels are those of Figure 2, measured across a 50 k $\Omega$  resistor.
- b) The current levels are:
  - 1) 3,5 mA r.m.s. for sinusoidal waveforms, 5 mA peak for non-sinusoidal waveforms or mixed frequencies, or 15 mA d.c., when measured with the measuring circuit of Figure A.1. If the frequency does not exceed 100 Hz, the measuring circuit of Figure A.2 can be used. The measuring circuit of Figure A.4 is used for equipment intended for use in WET LOCATIONS;
  - 2) 500 mA r.m.s. when measured with the measuring circuit of Figure A.3. This relates to possible burns at higher frequencies.
- c) The capacitance level is line B of Figure 3.

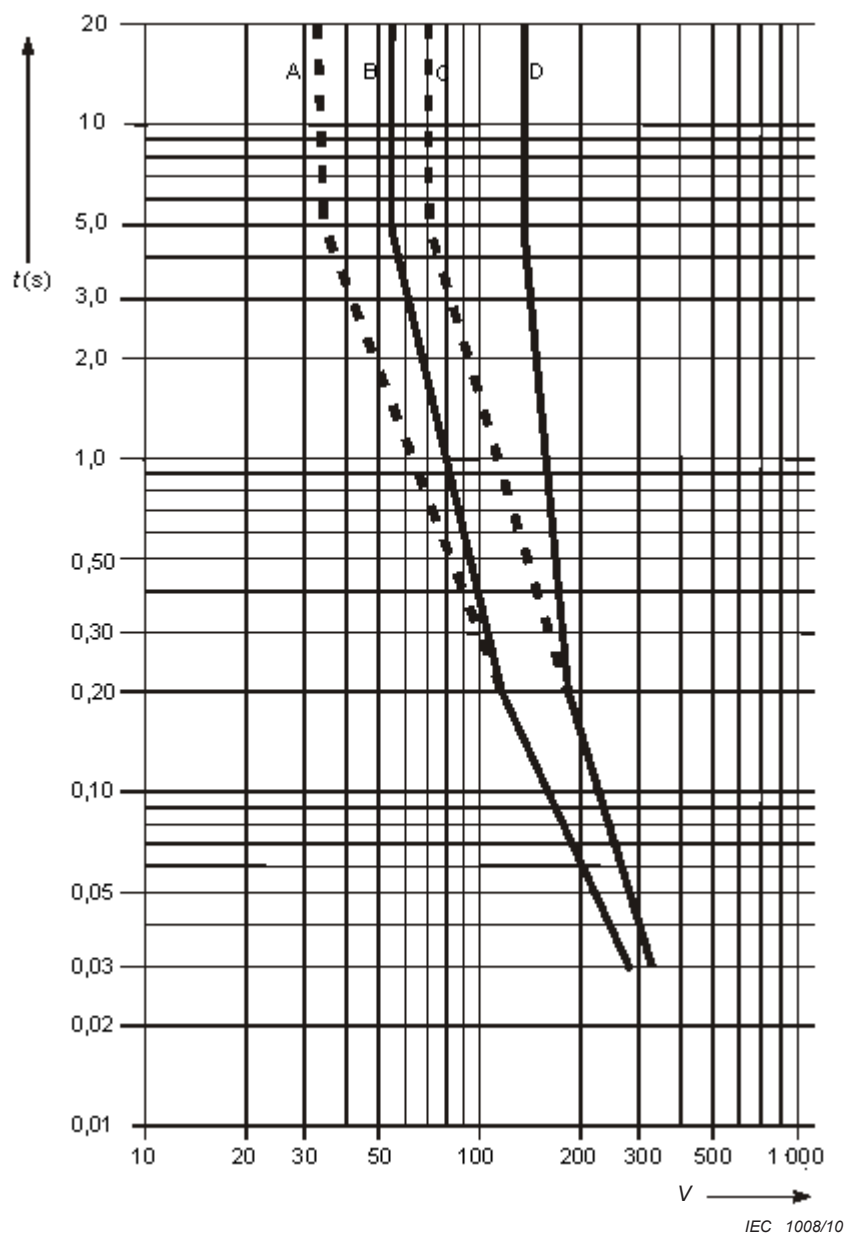

**Key**

- |   |                                     |   |                                     |
|---|-------------------------------------|---|-------------------------------------|
| A | a.c. voltage level in WET LOCATIONS | C | d.c. voltage level in WET LOCATIONS |
| B | a.c. voltage level in dry locations | D | d.c. voltage level in dry locations |

**Figure 2 – Maximum duration of short-term ACCESSIBLE voltages in SINGLE FAULT CONDITION (see 6.3.2 a))**

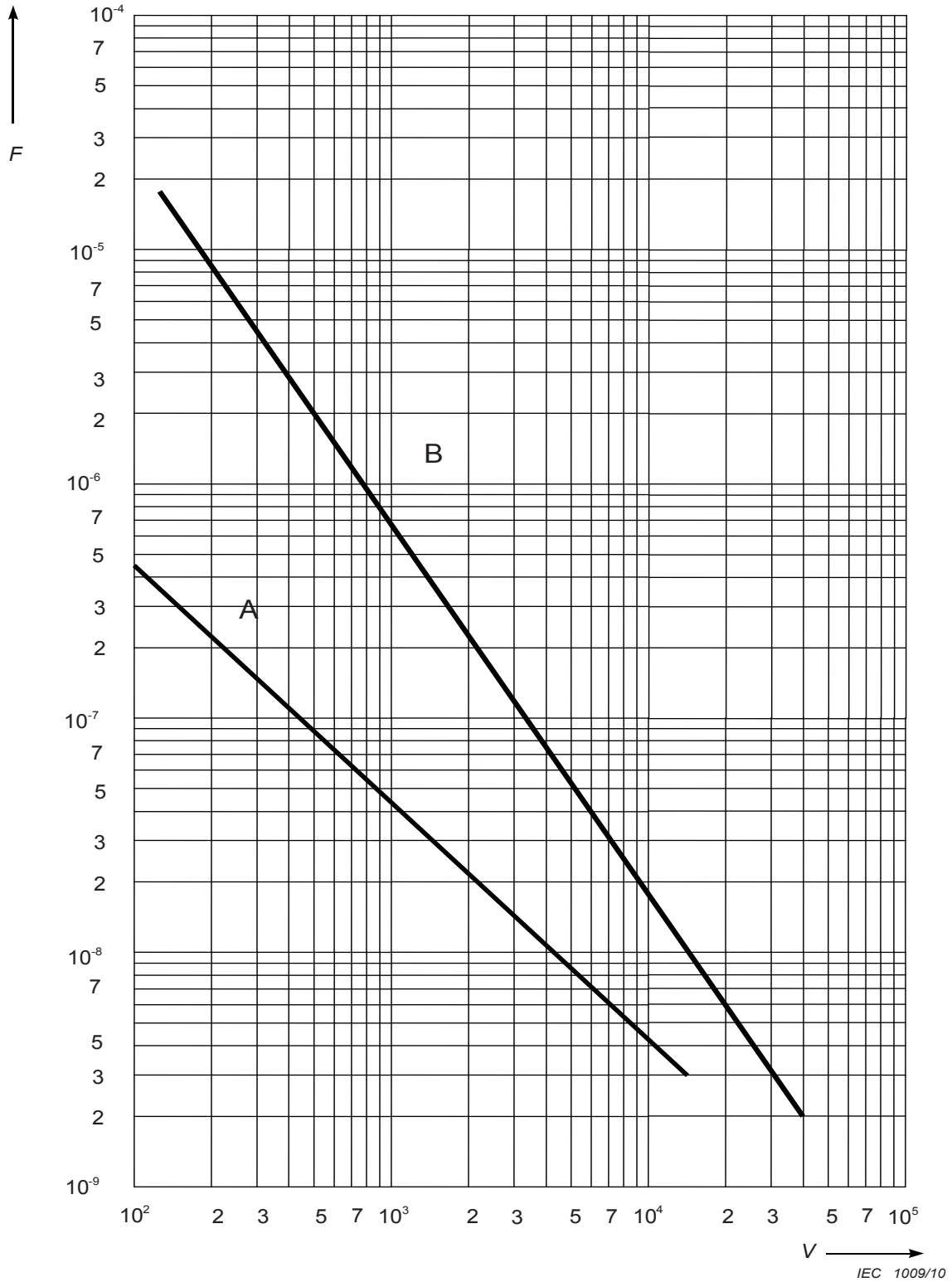

**Key**

- A NORMAL CONDITION
- B SINGLE FAULT CONDITION

**Figure 3 – Capacitance level versus voltage in NORMAL CONDITION and SINGLE FAULT CONDITION (see 6.3.1 c) and 6.3.2 c))**

## **6.4 Primary means of protection**

### **6.4.1 General**

ACCESSIBLE parts shall be prevented from becoming HAZARDOUS LIVE by one or more of the following means (see Annex D):

- a) ENCLOSURES or PROTECTIVE BARRIERS (see 6.4.2);
- b) BASIC INSULATION (see 6.4.3);
- c) impedance (see 6.4.4).

*Conformity is checked by inspection and as specified in 6.4.2. to 6.4.4.*

### **6.4.2 ENCLOSURES and PROTECTIVE BARRIERS**

ENCLOSURES and PROTECTIVE BARRIERS shall meet the rigidity requirements of 8.1.

If ENCLOSURES or PROTECTIVE BARRIERS provide protection by insulation, they shall meet the requirements of BASIC INSULATION.

If ENCLOSURES or PROTECTIVE BARRIERS provide protection by limiting access, CLEARANCES and CREEPAGE DISTANCES between ACCESSIBLE parts and HAZARDOUS LIVE parts shall meet the requirements of 6.7 and the applicable requirements for BASIC INSULATION.

*Conformity is checked as specified in 6.7 and 8.1.*

### **6.4.3 BASIC INSULATION**

CLEARANCES, CREEPAGE DISTANCES and solid insulation forming BASIC INSULATION between ACCESSIBLE parts and HAZARDOUS LIVE parts shall meet the requirements of 6.7.

*Conformity is checked as specified in 6.7.*

### **6.4.4 Impedance**

An impedance used as a primary means of protection shall meet all the following requirements:

- a) it shall limit the current or voltage to not more than the applicable level of 6.3.2;
- b) it shall be RATED for the maximum WORKING VOLTAGE and for the amount of power that it will dissipate;
- c) CLEARANCE and CREEPAGE DISTANCE between terminations of the impedance shall meet the applicable requirements of 6.7 for BASIC INSULATION.

*Conformity is checked by inspection, by measuring the voltage or current to confirm that they do not exceed the levels of 6.3.2, and by measuring CLEARANCE and CREEPAGE DISTANCE as specified in 6.7.*

## **6.5 Additional means of protection in case of SINGLE FAULT CONDITIONS**

### **6.5.1 General**

ACCESSIBLE parts shall be prevented from becoming HAZARDOUS LIVE in SINGLE FAULT CONDITION. The primary means of protection (see 6.4) shall be supplemented by one of a), b), c) or d). Alternatively one of the single means of protection e) or f) shall be used. See Figure 4 and Annex D.

- a) PROTECTIVE BONDING (see 6.5.2);
- b) SUPPLEMENTARY INSULATION (see 6.5.3);

- c) automatic disconnection of the supply (see 6.5.5);
- d) current- or voltage-limiting device (see 6.5.6);
- e) REINFORCED INSULATION (see 6.5.3);
- f) PROTECTIVE IMPEDANCE (see 6.5.4).

Conformity is checked by inspection and as specified in 6.5.2 to 6.5.6.

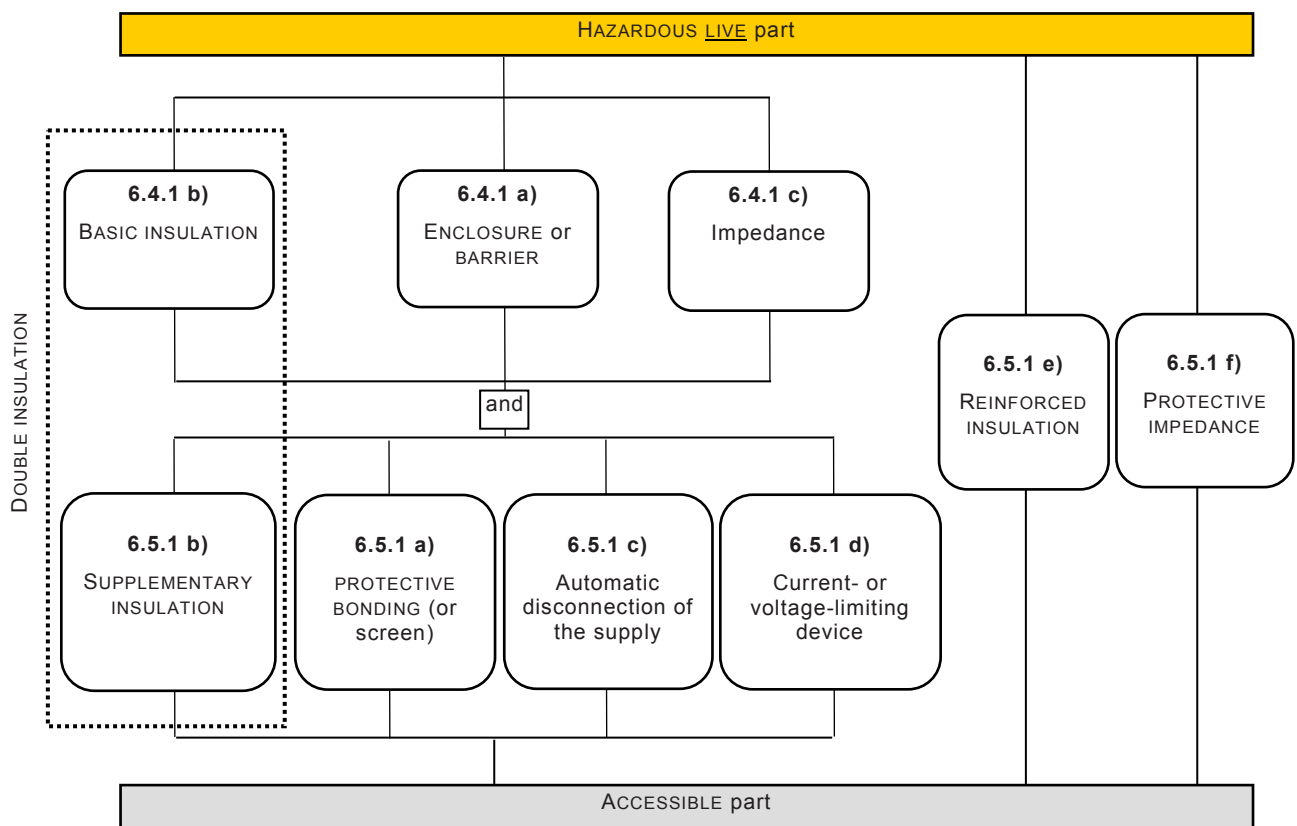

IEC 1010/10

Figure 4 – Acceptable arrangement of protective means against electric shock

## 6.5.2 PROTECTIVE BONDING

### 6.5.2.1 General

ACCESSIBLE conductive parts shall be bonded to the PROTECTIVE CONDUCTOR TERMINAL if they could become HAZARDOUS LIVE in case of a single fault of the primary means of protection specified in 6.4. Alternatively, such ACCESSIBLE parts shall be separated from parts which are HAZARDOUS LIVE by a conductive protective screen bonded to the PROTECTIVE CONDUCTOR TERMINAL.

Conformity is checked as specified in 6.5.2.2 to 6.5.2.6.

### 6.5.2.2 Integrity of PROTECTIVE BONDING

The integrity of PROTECTIVE BONDING shall be assured as specified below.

- a) PROTECTIVE BONDING shall consist of directly connected structural parts or discrete conductors, or both. It shall withstand all thermal and dynamic stresses to which it could be subjected before one of the overcurrent protective means specified in 9.6 disconnects the equipment from the supply.

- b) Soldered connections subject to mechanical stress shall be mechanically secured independently from the soldering. Such connections shall not be used for other purposes such as fixing constructional parts.
- c) Screw connections shall be secured against loosening.
- d) If a part of the equipment is removable by an OPERATOR, the PROTECTIVE BONDING for the remainder of the equipment shall not be interrupted (except for a part that also carries the MAINS input connection to the whole equipment).
- e) Unless they are specifically designed for electrical inter-connection and meet the requirements of 6.5.2.4, movable conductive connections, for example, hinges, slides, etc., shall not be the sole PROTECTIVE BONDING path.
- f) The exterior metal braid of cables shall not be regarded as PROTECTIVE BONDING, even if connected to the PROTECTIVE CONDUCTOR TERMINAL.
- g) If power from the MAINS supply is passed through equipment for use by other equipment, means shall also be provided for passing the protective conductor through the equipment to protect the other equipment. The impedance of the protective conductor path through the equipment shall not exceed that specified in 6.5.2.4.
- h) Protective conductors may be bare or insulated. Insulation shall be green-and-yellow, except in the following cases:
  - 1) for earthing braids, either green-and-yellow or colourless-transparent;
  - 2) for internal protective conductors, and other conductors connected to the PROTECTIVE CONDUCTOR TERMINAL in assemblies such as ribbon cables, busbars, flexible printed wiring, etc., any colour may be used provided that no HAZARD is likely to arise from non-identification of the protective conductor.

Equipment using PROTECTIVE BONDING shall be provided with a TERMINAL that is suitable for connection to a protective conductor and meets the requirements of 6.5.2.3.

*Conformity is checked by inspection.*

### **6.5.2.3 PROTECTIVE CONDUCTOR TERMINAL**

PROTECTIVE CONDUCTOR TERMINALS shall meet the following requirements.

- a) The contact surfaces shall be metal.

NOTE 1—Materials of PROTECTIVE BONDING systems should be chosen to minimize electro-chemical corrosion between the TERMINAL and the protective conductor, or any other metal in contact with them.
- b) The integral protective conductor connection of an appliance inlet shall be regarded as the PROTECTIVE CONDUCTOR TERMINAL.
- c) For equipment provided with a rewirable flexible cord and for PERMANENTLY CONNECTED EQUIPMENT, the PROTECTIVE CONDUCTOR TERMINAL shall be located near the MAINS supply TERMINALS.
- d) If the equipment does not require connection to a MAINS supply, but nevertheless has a circuit or part which is required to be protectively earthed, the PROTECTIVE CONDUCTOR TERMINAL shall be located near the TERMINALS of that circuit for which protective earthing is necessary. If this circuit has external TERMINALS, the PROTECTIVE CONDUCTOR TERMINAL shall also be external.
- e) PROTECTIVE CONDUCTOR TERMINALS for MAINS CIRCUITS shall be at least equivalent in current-carrying capacity to the MAINS supply TERMINALS.
- f) Plug-in type PROTECTIVE CONDUCTOR TERMINALS combined with other TERMINALS and intended to be connected and disconnected without the use of a TOOL, shall be designed so that the protective conductor connection makes first and breaks last with respect to the other connections. Examples include plugs and appliance couplers for MAINS cords and connector assemblies of plug-in units.
- g) If the PROTECTIVE CONDUCTOR TERMINAL is also used for other bonding purposes, the protective conductor shall be applied first and secured independently of other connections.

The protective conductor shall be connected in such a way that it is unlikely to be removed during servicing that does not require disconnection of the protective conductor.

h) For equipment in which the protective conductor is required for protection against a single fault in a measuring circuit, the following shall apply:

- 1) the PROTECTIVE CONDUCTOR TERMINAL and protective conductor shall have at least the current RATING of the measuring TERMINALS;
- 2) the PROTECTIVE BONDING shall not be interrupted by any switching or interrupting device.

i) FUNCTIONAL EARTH TERMINALS (for example, measuring earth TERMINALS) shall allow a connection which is independent from the connection of the protective conductor.

NOTE Equipment can be equipped with FUNCTIONAL EARTH TERMINALS, irrespective of the protective means taken.

j) If the PROTECTIVE CONDUCTOR TERMINAL is a binding screw assembly (see Figure 5), it shall be of a suitable size for the bond wire, but with a thread size no smaller than 4,0 mm, with at least three turns of the screw engaged.

k) The contact pressure required for a bonding connection shall not be capable of being reduced by deformation of materials forming part of the connection.

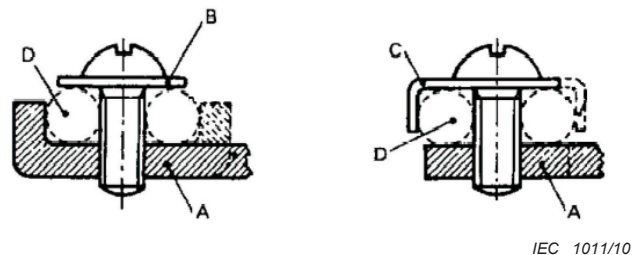

**Key**

- A fixed part
- B washer or clamping plate
- C anti-spread device
- D conductor space

**Figure 5 – Examples of binding screw assemblies**

Conformity is checked by inspection. Conformity for j) is also checked by the following test.

The binding screw assembly is to be tightened and loosened three times, together with the least favourable conductor to be secured, using the tightening torques specified in Table 2. All parts of the binding screw assembly shall withstand this test without mechanical failure.

**Table 2 – Tightening torque for binding screw assemblies**

Thread size mm	4,0	5,0	6,0	8,0	10,0
Tightening torque N·m	1,2	2,0	3,0	6,0	10,0

**6.5.2.4 Impedance of PROTECTIVE BONDING of plug-connected equipment**

The impedance between the PROTECTIVE CONDUCTOR TERMINAL and each ACCESSIBLE part for which PROTECTIVE BONDING is specified shall not exceed 0,1 Ω. If the equipment has a non-detachable power cord, the impedance between the protective conductor plug pin of the MAINS cord and each ACCESSIBLE part for which PROTECTIVE BONDING is specified shall not exceed 0,2 Ω.



*Conformity is checked by applying a test current for 1 min and then calculating impedance. The test current is the greater of:*

- a) *25 A a.c. r.m.s. at RATED MAINS frequency or d.c.;*
- b) *a current equal to twice the RATED current of the equipment.*

*If the equipment contains overcurrent protection devices for all poles of the MAINS supply, and if the wiring on the supply side of the overcurrent protection devices cannot become connected to ACCESSIBLE conductive parts in the case of a single fault, the test current need not be more than twice the RATED current of the internal overcurrent protection devices.*

#### **6.5.2.5 Impedance of PROTECTIVE BONDING of PERMANENTLY CONNECTED EQUIPMENT**

PROTECTIVE BONDING of PERMANENTLY CONNECTED EQUIPMENT shall be of low impedance.

*Conformity is checked by applying a test current of twice the value of the overcurrent protection means specified in the equipment installation instructions for the building supply MAINS CIRCUIT for 1 min between the PROTECTIVE CONDUCTOR TERMINAL and each ACCESSIBLE conductive part for which PROTECTIVE BONDING is required. The voltage between them shall not exceed 10 V a.c. r.m.s. or d.c.*

*If the equipment contains overcurrent protection devices for all poles of the MAINS supply, and if the wiring on the supply side of the overcurrent protection devices cannot become connected to ACCESSIBLE conductive parts in the case of a single fault, the test current need not be more than twice the RATED current of the internal overcurrent protection devices.*

#### **6.5.2.6 Transformer PROTECTIVE BONDING screen**

If the transformer is fitted with a screen for PROTECTIVE BONDING purposes that is separated only by BASIC INSULATION from a winding that is connected to a HAZARDOUS LIVE circuit, the screen shall satisfy the requirements of 6.5.2.2 a) and b), and be of low impedance.

*Conformity is checked by inspection and by one of the following tests:*

- a) *a test current of twice the value of the overcurrent protection means of the winding is applied for 1 min between the screen and the PROTECTIVE CONDUCTOR TERMINAL. The voltage between them shall not exceed 10 V a.c. r.m.s. or d.c.;*
- b) *the test of 6.5.2.4 using test current twice the value of the overcurrent protection means of the winding. The impedance shall not exceed 0,1  $\Omega$ .*

*NOTE If test a) or b) is carried out, a specially prepared sample transformer having an extra lead-out wire from the free end of the screen is used to ensure that the current during the test passes through the screen.*

#### **6.5.3 SUPPLEMENTARY INSULATION and REINFORCED INSULATION**

CLEARANCES, CREEPAGE DISTANCES and solid insulation forming SUPPLEMENTARY INSULATION or REINFORCED INSULATION shall meet the applicable requirements of 6.7.

*Conformity is checked as specified in 6.7.*

#### **6.5.4 PROTECTIVE IMPEDANCE**

A PROTECTIVE IMPEDANCE shall limit the current or voltage to the levels of 6.3.1 in NORMAL CONDITION and 6.3.2 in SINGLE FAULT CONDITION.

Insulation between the terminations of the PROTECTIVE IMPEDANCE shall meet the requirements of 6.7 for DOUBLE INSULATION or REINFORCED INSULATION.

A PROTECTIVE IMPEDANCE shall be one or more of the following:

- a) an appropriate single component which shall be constructed, selected and tested so that safety and reliability for protection against electric shock is assured. In particular, the component shall be:
  - 1) RATED for twice the maximum WORKING VOLTAGE;
  - 2) if a resistor, RATED for twice the power dissipation for the maximum WORKING VOLTAGE.
- b) a combination of components.

A PROTECTIVE IMPEDANCE shall not be a single electronic device that employs electron conduction in a vacuum, gas or semiconductor

*Conformity is checked by inspection, by measuring the current or voltage to confirm that they do not exceed the applicable levels of 6.3 and by measuring CLEARANCES and CREEPAGE DISTANCES as specified in 6.7. Conformity of a single component is checked by inspection of its RATINGS.*

### **6.5.5 Automatic disconnection of the supply**

An automatic disconnection device shall meet both the following requirements.

- a) It shall be RATED to disconnect the load within the time specified in Figure 2.
- b) It shall be RATED for the maximum RATED load conditions of the equipment.

*Conformity is checked by inspection of the device specification. In case of doubt, the device is tested to check that it disconnects the supply within the required time.*

### **6.5.6 Current- or voltage-limiting device**

A current- or voltage-limiting device shall meet all the following requirements:

- a) it shall be RATED to limit the current or voltage to the levels not exceeding the values of 6.3.2;
- b) it shall be RATED for the maximum WORKING VOLTAGE and, if applicable, for the maximum operational current;
- c) CLEARANCE and CREEPAGE DISTANCE between the terminations of the current or voltage-limiting device shall meet the applicable requirements of 6.7 for SUPPLEMENTARY INSULATION.

*Conformity is checked by inspection, by measuring the voltage or current to confirm that they do not exceed the levels of 6.3.2, and by measuring CLEARANCES and CREEPAGE DISTANCES as specified in 6.7.*

## **6.6 Connections to external circuits**

### **6.6.1 General**

In NORMAL CONDITION and in SINGLE FAULT CONDITION of the equipment, no ACCESSIBLE parts of the equipment and no ACCESSIBLE parts of an external circuit shall become HAZARDOUS LIVE as a result of connecting the external circuit to the equipment.

NOTE 1 External circuits are all circuits connected to TERMINALS of the equipment.

NOTE 2 For connection to MAINS supply source, see 6.10.

Protection shall be achieved by separation of circuits, unless short-circuiting of the separation could not cause a HAZARD.

The manufacturer's instructions or equipment markings shall include the following information, if applicable, for each external TERMINAL:

- a) RATED conditions at which the TERMINAL has been designed to operate while maintaining safety (maximum RATED input/output voltage, specific type of connector, designated use, etc.);
- b) RATING of the insulation required for the external circuit to conform to the requirements for protection against electric shock, arising from the connection to the TERMINAL, in NORMAL CONDITION and SINGLE FAULT CONDITION.

*Conformity is checked by:*

- 1) *inspection;*
- 2) *the determinations of 6.2;*
- 3) *the measurements of 6.3 and 6.7;*
- 4) *the voltage test of 6.8 (without humidity preconditioning) applicable to the type of insulation (see 6.7).*

### **6.6.2 TERMINALS for external circuits**

ACCESSIBLE conductive parts of TERMINALS that receive a charge from an internal capacitor shall not be HAZARDOUS LIVE 10 s after interruption of the supply.

*Conformity is checked by inspection, and by the determination of ACCESSIBLE conductive parts as specified in 6.2 and in case of doubt by measurement of the remaining voltage or charge.*

Female TERMINALS shall be such that a wire cannot be inserted through the TERMINAL to touch other internal HAZARDOUS LIVE conductive parts.

Conformity is checked by inspection and by test with the 100 mm × 1 mm test pin of 6.2.5 to determine whether a wire can be inserted through the TERMINAL.

TERMINALS on the equipment that can be HAZARDOUS LIVE shall be such that the HAZARDOUS LIVE conductive parts of the TERMINAL are not ACCESSIBLE.

Conformity is checked by inspection.

### **6.6.3 Circuits with TERMINALS which are HAZARDOUS LIVE**

These circuits shall not be connected to ACCESSIBLE conductive parts, except for circuits which are not MAINS CIRCUITS, and which are designed to be operated with one TERMINAL contact at earth potential. In such cases, the ACCESSIBLE conductive parts shall not be HAZARDOUS LIVE.

If such a circuit is also designed to be operated with one ACCESSIBLE TERMINAL contact (~~signal low~~) floating at a voltage which is not HAZARDOUS LIVE, this TERMINAL contact is permitted to be connected to a common FUNCTIONAL EARTH TERMINAL or system (for example, a coaxial screening system). This common FUNCTIONAL EARTH TERMINAL or system is also permitted to be connected to other ACCESSIBLE conductive parts.

*Conformity is checked by inspection.*

### **6.6.4 TERMINALS for stranded conductors**

TERMINALS for stranded conductors shall be located or shielded so that there is no possibility of accidental contact between HAZARDOUS LIVE parts of different polarity or between such parts and other ACCESSIBLE parts, even if a strand of a conductor escapes from a TERMINAL. Unless it is self-evident (which is preferable) TERMINALS shall be marked to show whether or not they are connected to ACCESSIBLE conductive parts (see 5.1.5.2 c)).

*Conformity is checked by inspection after fully inserting a stranded conductor with an 8 mm length of insulation removed, with one of the strands free. The strand shall not touch parts of different polarity or other ACCESSIBLE parts, when bent in every possible direction, without tearing back the insulation or making sharp bends.*

TERMINALS of circuits carrying HAZARDOUS LIVE voltage or current shall be anchored, fitted or designed so that conductors will not work loose when they are tightened, loosened or when connections are made.

*Conformity is checked by manual test and inspection.*

## **6.7 Insulation requirements**

### **6.7.1 The nature of insulation**

#### **6.7.1.1 General**

Insulation between circuits and ACCESSIBLE parts (see 6.2) or between separate circuits consists of a combination of CLEARANCES, CREEPAGE DISTANCES and solid insulation. When used to provide protection against a HAZARD, the insulation needs to withstand the electric stresses that are caused by the voltages that may appear on the MAINS supply or in the equipment.

Electric stresses originating from MAINS include:

- a) WORKING VOLTAGE across the insulation. This WORKING VOLTAGE is normally the line-to-neutral voltage of the MAINS supply (also see Annex I);
- b) TRANSIENT OVERVOLTAGES that may occasionally appear on the line conductors. The magnitude of the overvoltages depends on the OVERVOLTAGE CATEGORY and the line-to-neutral voltage of the MAINS supply;
- c) short-term TEMPORARY OVERVOLTAGES that may occur between the line conductor and earth in electrical installations. These TEMPORARY OVERVOLTAGES may have a value of the line-to-neutral voltage of the MAINS supply plus 1 200 V, and may last up to 5 s;
- d) long-term TEMPORARY OVERVOLTAGES that may occur between the line conductor and earth in electrical installations. These TEMPORARY OVERVOLTAGES may have a value of the line-to-neutral voltage of the MAINS supply plus 250 V and may last longer than 5 s.

NOTE See IEC 60364-4-44:2007, Clause 442 for additional information on these TEMPORARY OVERVOLTAGES.

The requirements for insulation depend on:

- 1) the required level of insulation (BASIC INSULATION, SUPPLEMENTARY INSULATION, or REINFORCED INSULATION);
- 2) the maximum TRANSIENT OVERVOLTAGE that may appear on the circuit, either as a result of an external event (such as a lightning strike or a switching transient), or as the result of the operation of the equipment;
- 3) the maximum WORKING VOLTAGE (including steady-state and recurring peak voltages);
- 4) the POLLUTION DEGREE of the micro-environment;
- 5) the maximum TEMPORARY OVERVOLTAGE that may occur in a MAINS CIRCUIT because of a fault in the MAINS distribution system.

#### **6.7.1.2 CLEARANCES**

Required CLEARANCES depend on the factors in 6.7.1.1 a) to d) as well as the RATED altitude for operation. If the equipment is RATED to operate at an altitude greater than 2 000 m, all CLEARANCES shall be multiplied by the applicable factor of Table 3.

**Table 3 – Multiplication factors for CLEARANCES of equipment  
 RATED for operation at altitudes up to 5 000 m**

<b>RATED operating altitude m</b>	<b>Multiplication factor</b>
Up to 2 000	1,00
2 001 to 3 000	1,14
3 001 to 4 000	1,29
4 001 to 5 000	1,48

See Annex C for details of how to measure CLEARANCES.

### 6.7.1.3 CREEPAGE DISTANCES

Required CREEPAGE DISTANCES depend on the factors in 6.7.1.1 a) to d) as well as the Comparative Tracking Index (CTI) of the insulating material.

Materials are separated into four groups according to their CTI values, as follows:

Material group I	$600 \leq \text{CTI}$
Material group II	$400 \leq \text{CTI} < 600$
Material group IIIa	$175 \leq \text{CTI} < 400$
Material group IIIb	$100 \leq \text{CTI} < 175$

These CTI values refer to values obtained, in accordance with IEC 60112, on samples of the relevant material specifically made for the purpose and tested with solution A. For materials where the CTI value is not known, material group IIIb is assumed.

For glass, ceramics, or other inorganic insulating materials which do not track, there are no requirements for CREEPAGE DISTANCES.

See Annex C for details of how to measure CREEPAGE DISTANCES.

### 6.7.1.4 Solid insulation

The requirements for solid insulation depend on the factors in 6.7.1.1 a) to d).

The term “solid insulation” is used to describe many different types of construction, including monolithic blocks of insulating material and insulation subsystems composed of multiple insulating materials, organized in layers or otherwise.

The electric strength of a thickness of solid insulation is considerably greater than that of the same thickness of air. The insulating distances through solid insulation are therefore typically smaller than the distances through air. As a result, electric fields in solid insulation are typically higher, and often are less homogeneous.

Solid insulation material may contain gaps or voids. When a solid insulation system is constructed from layers of solid materials, there are also likely to be gaps or voids between layers. These voids will perturb the electric field so that a disproportionately large part of the electric field is located in the void, potentially causing ionization within the void, resulting in partial discharge. These partial discharges will influence the adjacent solid insulation and may reduce its service life.

Solid insulation is not a renewable medium: damage is cumulative over the life of the equipment. Solid insulation is also subject to ageing and to degradation from repeated high voltage testing.

#### **6.7.1.5 Requirements for insulation according to type of circuit**

Requirements for insulation in particular types of circuits are specified as follows:

- a) in 6.7.2 for MAINS CIRCUITS of OVERVOLTAGE CATEGORY II with a nominal supply voltage up to 300 V;

NOTE 1 See Annex I for nominal voltages of MAINS supplies.

- b) in 6.7.3 for secondary circuits separated from the circuits in a) only by means of a transformer;

- c) in K.1 for MAINS CIRCUITS of OVERVOLTAGE CATEGORY III or IV or for OVERVOLTAGE CATEGORY II over 300 V;

- d) in K.2 for secondary circuits separated from the circuits in c) only by means of a transformer

- e) in K.3 for circuits that have one or more of the following characteristics:

- 1) the maximum possible TRANSIENT OVERVOLTAGE is limited by the supply source or within the equipment to a known level below the level assumed for the MAINS CIRCUIT;
- 2) the maximum possible TRANSIENT OVERVOLTAGE is above the level assumed for the MAINS CIRCUIT;
- 3) the WORKING VOLTAGE is the sum of voltages from more than one circuit, or is a mixed voltage;
- 4) the WORKING VOLTAGE includes a recurring peak voltage that may include a periodic non-sinusoidal waveform or a non-periodic waveform that occurs with some regularity;
- 5) the WORKING VOLTAGE has a frequency above 30 kHz.

NOTE 2 Requirements for insulation of measuring circuits are specified in IEC 61010-2-030.

NOTE 3 See K.3 for requirements for switching circuits such as a switching power supply.

### **6.7.2 Insulation for MAINS CIRCUITS of OVERVOLTAGE CATEGORY II with a nominal supply voltage up to 300 V**

#### **6.7.2.1 CLEARANCES and CREEPAGE DISTANCES**

CLEARANCES and CREEPAGE DISTANCES for MAINS CIRCUITS shall meet the values of Table 4 taking the following into account:

- a) the values in Table 4 are for BASIC INSULATION and SUPPLEMENTARY INSULATION. Values for REINFORCED INSULATION shall be twice the values for BASIC INSULATION;
- b) minimum CLEARANCE for BASIC INSULATION, SUPPLEMENTARY INSULATION and REINFORCED INSULATION for POLLUTION DEGREE 3 is 0,8 mm;
- c) if the equipment is RATED to operate at an altitude greater than 2 000 m, the CLEARANCES shall be multiplied by the applicable factor of Table 3.

*Conformity is checked by inspection and measurement.*

**Table 4 – CLEARANCES and CREEPAGE DISTANCES for MAINS CIRCUITS of OVERVOLTAGE CATEGORY II up to 300 V**

Voltage line-to-neutral a.c. r.m.s. or d.c.	Values for CLEAR-ANCE	Values for CREEPAGE DISTANCE								
		Printed wiring board material			Other insulating material					
		POLLUTION DEGREE 1	POLLUTION DEGREE 2	POLLUTION DEGREE 1	POLLUTION DEGREE 2			POLLUTION DEGREE 3		
		All material groups	Material groups I, II, IIIa	All material groups	Material group I	Material group II	Material group III	Material group I	Material group II	Material group III
V	mm	mm	mm	mm	mm	mm	mm	mm	mm	mm
≤ 150	0,5	0,5	0,5	0,5	0,8	1,1	1,6	2,0	2,2	2,5
> 150 ≤ 300	1,5	1,5	1,5	1,5	1,5	2,1	3,0	3,8	4,1	4,7

Coatings that meet the requirements of Annex H when applied to the outer surfaces of printed wiring boards reduce the POLLUTION DEGREE of the coated area to POLLUTION DEGREE 1.

*Conformity of coatings is checked as specified in Annex H.*

### 6.7.2.2 Solid insulation

#### 6.7.2.2.1 General

Solid insulation of MAINS CIRCUITS shall withstand the electric and mechanical stresses that may occur in NORMAL USE, in all RATED environmental conditions (see 1.4), during the intended life of the equipment.

**NOTE**—The manufacturer should take the expected life of the equipment into account when selecting insulating materials.

*Conformity is checked by inspection, and by the a.c. test of 6.8.3.1 with a duration of at least 1 min, or for MAINS CIRCUITS stressed only by d.c., the 1 min d.c. test of 6.8.3.2, using the applicable voltage from Table 5.*

**Table 5 – Test voltages for solid insulation in MAINS CIRCUITS of OVERVOLTAGE CATEGORY II up to 300 V**

Voltage line-to-neutral a.c. r.m.s. or d.c.	1 min a.c. test voltage		1 min d.c. test voltage	
	BASIC INSULATION and SUPPLEMENTARY INSULATION	REINFORCED INSULATION	BASIC INSULATION and SUPPLEMENTARY INSULATION	REINFORCED INSULATION
V	V	V	V	V
≤ 150	1 350	2 700	1 900	3 800
> 150 ≤ 300	1 500	3 000	2 100	4 200

Solid insulation shall also meet the following requirements, as applicable:

- for solid insulation used as an ENCLOSURE or PROTECTIVE BARRIER, the requirements of Clause 8;
- for moulded and potted parts, the requirements of 6.7.2.2.2;
- for inner layers of printed wiring boards, the requirements of 6.7.2.2.3;
- for thin-film insulation, the requirements of 6.7.2.2.4.



Conformity is checked as specified in 6.7.2.2.2 to 6.7.2.2.4, and in Clause 8, as applicable.

### 6.7.2.2.2 Moulded and potted parts

For BASIC INSULATION, SUPPLEMENTARY INSULATION and REINFORCED INSULATION, conductors located on an interface between the same two layers moulded together shall be separated by at least 0,4 mm (see Figure 6, item L) after the moulding is completed.

Conformity is checked by inspection and either by measurement of the separation or by inspection of the manufacturer's specifications.

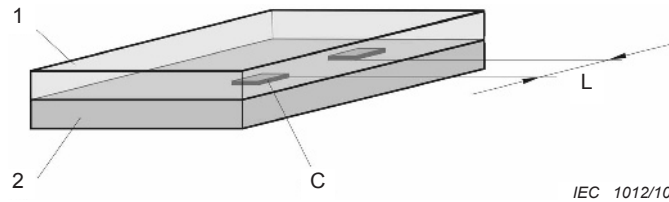

#### Key

- 1 Layer 1
- 2 Layer 2
- C Conductor
- L Distance between conductors

Figure 6 – Distance between conductors on an interface between two layers

### 6.7.2.2.3 Inner insulating layers of printed wiring boards

For BASIC INSULATION, SUPPLEMENTARY INSULATION and REINFORCED INSULATION, conductors located between the same two layers shall be separated by at least 0,4 mm (see Figure 7, item L).

Conformity is checked by inspection and either by measurement of the separation or by inspection of the manufacturer's specifications.

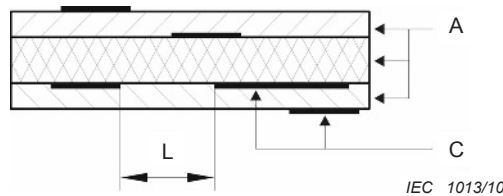

#### Key

- L Distance between adjacent conductors
- A Layers
- C Conductors

Figure 7 – Distance between adjacent conductors along an interface of two inner layers



REINFORCED INSULATION of inner insulating layers of printed wiring boards shall also have adequate electric strength through the respective layers. One of the following methods shall be used:

- a) the thickness of the insulation is at least 0,4 mm;

*Conformity is checked by inspection and either by measurement of the separation or by inspection of the manufacturer's specifications.*

- b) the insulation is assembled from at least two separate layers of printed wiring board materials, each of which is RATED by the manufacturer of the material for an electric strength of at least the value of the test voltage of Table 5 for BASIC INSULATION;

*Conformity is checked by inspection of the manufacturer's specifications.*

- c) the insulation is assembled from at least two separate layers of printed wiring board materials, and the combination of layers is RATED by the manufacturer of the material for an electric strength of at least the value of the test voltage of Table 5 for REINFORCED INSULATION.

*Conformity is checked by inspection of the manufacturer's specifications.*

#### 6.7.2.2.4 Thin-film insulation

For BASIC INSULATION, SUPPLEMENTARY INSULATION and REINFORCED INSULATION, conductors located between the same two layers (see Figure 8, item L).shall be separated by the applicable CLEARANCE and CREEPAGE DISTANCE of 6.7.2.1.

*Conformity is checked by inspection and either by measurement of the separation or by inspection of the manufacturer's specifications.*

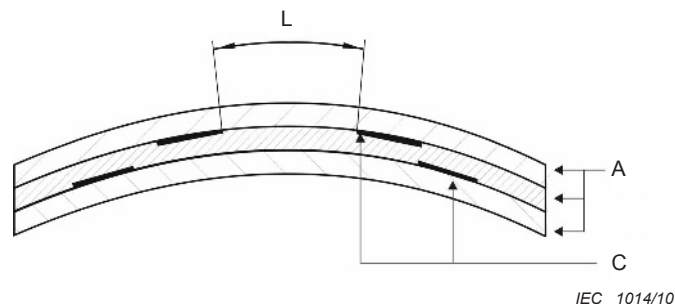

#### Key

- L Distance between adjacent conductors  
A Layers of thin-film material such as tape and polyester film  
C Conductors

NOTE Air is likely to be present between the layers.

**Figure 8 – Distance between adjacent conductors located between the same two layers**

REINFORCED INSULATION through the layers of thin-film insulation shall also have adequate electric strength. One of the following methods shall be used:

- a) the thickness through the insulation is at least 0,4 mm;

*Conformity is checked by inspection and either by measurement of the part or by inspection of the manufacturer's specifications.*

- b) the insulation consists of at least two separate layers of thin-film materials, each of which is RATED by the manufacturer of the material for an electric strength of at least the value of the test voltage of Table 5 for BASIC INSULATION;

*Conformity is checked by inspection of the manufacturer's specifications.*

- c) the insulation consists of at least three separate layers of thin-film materials, any two of which have been tested to exhibit adequate electric strength.

*Conformity is checked by the a.c. test of 6.8.3.1 with a duration of at least 1 min, or for MAINS CIRCUITS stressed only by d.c, the 1 min d.c. test of 6.8.3.2 applied to two of the three layers using the applicable voltage for REINFORCED INSULATION of Table 5.*

NOTE For the purposes of this test a special sample can be assembled with only two layers of the material.

### **6.7.3 Insulation for secondary circuits derived from MAINS CIRCUITS of OVERVOLTAGE CATEGORY II up to 300 V**

#### **6.7.3.1 General**

In this Technical Specification, secondary circuits are circuits where separation from MAINS CIRCUITS is achieved by a transformer in which the primary windings are separated from the secondary windings by REINFORCED INSULATION, DOUBLE INSULATION, or a screen connected to the PROTECTIVE CONDUCTOR TERMINAL.

NOTE These circuits are assumed to be subjected to lower TRANSIENT OVERVOLTAGE levels than the MAINS CIRCUIT.

#### **6.7.3.2 CLEARANCES**

CLEARANCES for secondary circuits shall meet a) or b):

- a) for BASIC INSULATION and SUPPLEMENTARY INSULATION, meet the values of Table 6, or for REINFORCED INSULATION meet twice the values of Table 6;
- b) pass the voltage test of 6.8 using the applicable test voltage from Table 6.

The following adjustments apply:

- 1) values for test voltages for REINFORCED INSULATION are 1,6 times the values for BASIC INSULATION;
- 2) if the equipment is RATED to operate at an altitude greater than 2 000 m, the values for CLEARANCES are multiplied by the applicable factor of Table 3;
- 3) minimum CLEARANCE is 0,2 mm for POLLUTION DEGREE 2 and 0,8 mm for POLLUTION DEGREE 3.

*Conformity is checked by inspection and measurement and for b) by the a.c. test of 6.8.3.1 with a duration of at least 5 s, or by the 1 min d.c. test of 6.8.3.2, using the applicable test voltage from Table 6. The value of the d.c. test voltage is  $\sqrt{2}$  times the a.c. r.m.s. test voltage.*

**Table 6 – CLEARANCES and test voltages for secondary circuits derived from MAINS CIRCUITS of OVERVOLTAGE CATEGORY II up to 300 V**

Secondary WORKING VOLTAGE		MAINS voltage, line-to-neutral, OVERVOLTAGE CATEGORY II			
		≤ 150 V a.c. r.m.s.		> 150 V ≤ 300 V a.c. r.m.s.	
a.c. r.m.s. V	d.c. or a.c. peak V	CLEARANCE mm	Test voltage V a.c. r.m.s.	CLEARANCE mm	Test voltage V a.c. r.m.s.
16	22,6	0,10	500	0,50	840
33	46,7	0,11	510	0,52	850
50	70	0,12	520	0,53	860
100	140	0,13	540	0,61	900
150	210	0,16	580	0,69	940
300	420	0,39	770	0,94	1 040
600	840	1,01	1 070	1,61	1 450
1 000	1 400	1,92	1 630	2,52	1 970
1 250	1 750	2,50	1 960	3,16	2 280
1 600	2 240	3,39	2 390	4,11	2 730
2 000	2 800	4,49	2 890	5,30	3 230
2 500	3 500	6,02	3 520	6,91	3 850
3 200	4 480	8,37	4 390	9,16	4 660
4 000	5 600	10,9	5 320	11,6	5 610
5 000	7 000	14,0	6 590	14,9	6 960
6 300	8 820	18,2	8 270	19,1	8 620
8 000	11 200	23,9	10 400	24,7	10 700
10 000	14 000	30,7	12 900	31,6	13 300
12 500	17 500	39,6	16 100	40,5	16 400
16 000	22 400	52,5	20 400	53,5	20 700
20 000	28 000	67,9	25 300	68,9	25 600
25 000	35 000	87,9	31 600	89,0	32 000
32 000	44 800	117	40 400	118	40 700
40 000	56 000	151	50 300	153	50 800
50 000	70 000	196	62 800	198	63 400
63 000	88 200	258	79 400	260	80 000

Linear interpolation is allowed.

### 6.7.3.3 CREEPAGE DISTANCES

CREEPAGE DISTANCES for BASIC INSULATION or SUPPLEMENTARY INSULATION for secondary circuits shall meet the applicable values of Table 7, based on the WORKING VOLTAGE which stresses the insulation. Values for REINFORCED INSULATION are twice the values for BASIC INSULATION.

*Conformity is checked by inspection and measurement.*

Coatings that meet the requirements of Annex H when applied to the outer surfaces of printed wiring boards reduce the POLLUTION DEGREE of the coated area to POLLUTION DEGREE 1.

*Conformity of coatings is checked as specified in Annex H.*

**Table 7 – CREEPAGE DISTANCES for secondary circuits**

Secondary WORKING VOLTAGE a.c. r.m.s. or d.c.	Printed wiring board material		Other insulating material						
	POLLUTION DEGREE 1	POLLUTION DEGREE 2	POLLUTION DEGREE 1	POLLUTION DEGREE 2			POLLUTION DEGREE 3		
	All material groups	Material groups I, II or IIIa	All material groups	Material group I	Material group II	Material group III	Material group I	Material group II	Material group III <sup>b</sup>
V	mm	mm	mm	mm	mm	mm	mm	mm	mm
10	0,025	0,04	0,08	0,40	0,40	0,40	1,00	1,00	1,00
12,5	0,025	0,04	0,09	0,42	0,42	0,42	1,05	1,05	1,05
16	0,025	0,04	0,10	0,45	0,45	0,45	1,10	1,10	1,10
20	0,025	0,04	0,11	0,48	0,48	0,48	1,20	1,20	1,20
25	0,025	0,04	0,125	0,50	0,50	0,50	1,25	1,25	1,25
32	0,025	0,04	0,14	0,53	0,53	0,53	1,3	1,3	1,3
40	0,025	0,04	0,16	0,56	0,80	1,10	1,4	1,6	1,8
50	0,025	0,04	0,18	0,60	0,85	1,20	1,5	1,7	1,9
63	0,040	0,063	0,20	0,63	0,90	1,25	1,6	1,8	2,0
80	0,063	0,10	0,22	0,67	0,95	1,3	1,7	1,9	2,1
100	0,10	0,16	0,25	0,71	1,00	1,4	1,8	2,0	2,2
125	0,16	0,25	0,28	0,75	1,05	1,5	1,9	2,1	2,4
160	0,25	0,40	0,32	0,80	1,1	1,6	2,0	2,2	2,5
200	0,40	0,63	0,42	1,00	1,4	2,0	2,5	2,8	3,2
250	0,56	1,0	0,56	1,25	1,8	2,5	3,2	3,6	4,0
320	0,75	1,6	0,75	1,60	2,2	3,2	4,0	4,5	5,0
400	1,0	2,0	1,0	2,0	2,8	4,0	5,0	5,6	6,3
500	1,3	2,5	1,3	2,5	3,6	5,0	6,3	7,1	8,0
630	1,8	3,2	1,8	3,2	4,5	6,3	8,0	9,0	10,0
800	2,4	4,0	2,4	4,0	5,6	8,0	10,0	11	12,5
1 000	3,2 <sup>a</sup>	5,0 <sup>a</sup>	3,2	5,0	7,1	10,0	12,5	14	16
1 250			4,2	6,3	9,0	12,5	16	18	20
1 600			5,6	8,0	11	16	20	22	25
2 000			7,5	10,0	14	20	25	28	32
2 500			10,0	12,5	18	25	32	36	40
3 200			12,5	16	22	32	40	45	50
4 000			16	20	28	40	50	56	63
5 000			20	25	36	50	63	71	80
6 300			25	32	45	63	80	90	100
8 000			32	40	56	80	100	110	125
10 000			40	50	71	100	125	140	160
12 500			50	63	90	125			
16 000			63	80	110	160			
20 000			80	100	140	200			
25 000			100	125	180	250			
32 000			125	160	220	320			
40 000			160	200	280	400			
50 000			200	250	360	500			
63 000			250	320	450	600			

Linear interpolation is allowed.

<sup>a</sup> For voltages above 1 000 V, CREEPAGE DISTANCES on printed wiring board material are the same as for other insulators of the same Material Group.

<sup>b</sup> Material group IIIb is not recommended for application in POLLUTION DEGREE 3 above 630 V.

### **6.7.3.4 Solid insulation**

#### **6.7.3.4.1 General**

Solid insulation in secondary circuits shall withstand the electrical and mechanical stresses that may occur in NORMAL USE, in all RATED environmental conditions (see 1.4), during the intended life of the equipment.

**NOTE**—The manufacturer should take the expected life of the equipment into account when selecting insulating materials.

*Conformity is checked by both of the following tests:*

- a) by the voltage test of 6.8.3.1 for 5 s using the applicable test voltage of Table 6 for BASIC INSULATION or SUPPLEMENTARY INSULATION. For REINFORCED INSULATION the values are multiplied by 1,6;*
- b) additionally, if the WORKING VOLTAGE exceeds 300 V, by the voltage test of 6.8.3.1 for 1 min with a test voltage of 1,5 times the WORKING VOLTAGE for BASIC INSULATION or SUPPLEMENTARY INSULATION and twice the WORKING VOLTAGE for REINFORCED INSULATION.*

Solid insulation shall also meet the following requirements, as applicable:

- 1) for solid insulation used as an ENCLOSURE or PROTECTIVE BARRIER, the requirements of Clause 8;
- 2) for moulded and potted parts, the requirements of 6.7.3.4.2;
- 3) for inner insulating layers of printed wiring boards, the requirements of 6.7.3.4.3;
- 4) for thin-film insulation, the requirements of 6.7.3.4.4.

*Conformity is checked as specified in 6.7.3.4.2 to 6.7.3.4.4 and Clause 8, as applicable.*

#### **6.7.3.4.2 Moulded and potted parts**

For BASIC INSULATION, SUPPLEMENTARY INSULATION and REINFORCED INSULATION, conductors located between the same two layers shall be separated by the applicable minimum distance of Table 8 (see Figure 6 item L).

*Conformity is checked by inspection and either by measurement of the separation or by inspection of the manufacturer's specifications.*

**Table 8 – Minimum values for distance or thickness  
 (see 6.7.3.4.2 to 6.7.3.4.4)**

Peak value of the a.c. or d.c. WORKING VOLTAGE or recurring peak voltage	Minimum value	Peak value of the a.c. or d.c. WORKING VOLTAGE or recurring peak voltage	Minimum value
kV	mm	kV	mm
> 0,046 7 ≤ 0,33	0,05	> 8,0 ≤ 10	3,5
> 0,33 ≤ 0,8	0,1	> 10 ≤ 12	4,5
> 0,8 ≤ 1,0	0,15	> 12 ≤ 15	5,5
> 1,0 ≤ 1,2	0,2	> 15 ≤ 20	8
> 1,2 ≤ 1,5	0,3	> 20 ≤ 25	10
> 1,5 ≤ 2,0	0,45	> 25 ≤ 30	12,5
> 2,0 ≤ 2,5	0,6	> 30 ≤ 40	17
> 2,5 ≤ 3,0	0,8	> 40 ≤ 50	22
> 3,0 ≤ 4,0	1,2	> 50 ≤ 60	27
> 4,0 ≤ 5,0	1,5	> 60 ≤ 80	35
> 5,0 ≤ 6,0	2	> 80 ≤ 100	45
> 6,0 ≤ 8,0	3		

#### 6.7.3.4.3 Inner insulating layers of printed wiring boards

For BASIC INSULATION, SUPPLEMENTARY INSULATION and REINFORCED INSULATION, conductors located between the same two layers shall be separated by the applicable minimum distance of Table 8 (see Figure 7, item L).

*Conformity is checked by inspection and either by measurement of the separation or by inspection of the manufacturer's specifications.*

REINFORCED INSULATION of inner insulating layers of printed wiring boards shall also have adequate electric strength through the respective layers. One of the following methods shall be used:

- a) the thickness of the insulation is at least the applicable minimum distance of Table 8;

*Conformity is checked by inspection and either by measurement of the separation or by inspection of the manufacturer's specifications.*

- b) the insulation is assembled from at least two separate layers of printed wiring board materials, each of which is RATED by the manufacturer of the material for an electric strength at least the value of the test voltage of Table 6 for BASIC INSULATION;

*Conformity is checked by inspection of the manufacturer's specifications.*

- c) the insulation is assembled from at least two separate layers of printed wiring board materials, and the combination of layers is RATED by the manufacturer of the material for an electric strength at least the value of the test voltage of Table 6 multiplied by 1,6.

*Conformity is checked by inspection of the manufacturer's specifications.*

#### 6.7.3.4.4 Thin-film insulation

For BASIC INSULATION, SUPPLEMENTARY INSULATION and REINFORCED INSULATION, conductors located between the same two layers (see Figure 8, item L) shall be separated by at least the applicable CLEARANCE and CREEPAGE DISTANCE of 6.7.3.2 and 6.7.3.3.

*Conformity is checked by measurement or by inspection of the part or the manufacturer's specifications.*

REINFORCED INSULATION through the layers of thin-film insulation shall also have adequate electric strength. One of the following methods shall be used:

- a) the thickness of the insulation is at least the applicable value of Table 8;

*Conformity is checked by inspection and either by measurement of the separation or by inspection of the manufacturer's specifications.*

- b) the insulation consists of at least two separate layers of thin-film materials, each of which is RATED by the manufacturer of the material for an electric strength of at least the value of the test voltage of Table 6 for BASIC INSULATION;

*Conformity is checked by inspection of the manufacturer's specifications.*

- c) the insulation consists of at least three separate layers of thin-film materials, any two of which have been tested to exhibit adequate electric strength.

*Conformity is checked by the a.c. test of 6.8.3.1 with a duration of at least 1 min, or, for circuits stressed only by d.c., the 1 min d.c. test of 6.8.3.2, using the applicable test voltage from Table 6 multiplied by 1,6, applied to two of the three layers.*

*NOTE—For the purposes of this test a special sample may be assembled with only two layers of the material.*

## 6.8 Procedure for voltage tests

### 6.8.1 General

*The following test procedures apply to type testing, and deterioration of the test specimen may occur. Further use of the test specimen may not be appropriate.*

*Test equipment for the voltage tests is specified in IEC 61180-1 and IEC 61180-2.*

*ACCESSIBLE insulating parts of the ENCLOSURE are covered with metal foil everywhere except around TERMINALS. For test voltages up to 10 kV a.c. peak or d.c., the distance from foil to TERMINAL is not more than 20 mm. For higher voltages it is the minimum to prevent flashover. For guidance to these minimum distances, see Table 9.*

*NOTE 1 The distances of Table 9 will prevent flashover between foil and TERMINALS.*

**Table 9 – Distances between TERMINALS and foil**

Test voltage	Distance
kV	mm
10	20
20	45
30	70
50	130
70	195
100	290

*ACCESSIBLE parts of controls with parts made of insulating material are wrapped in metal foil or have soft conductive material pressed against them.*

*The foil is applied after the humidity preconditioning (if applicable) and connected to the low TERMINAL of the test voltage generator.*

*The equipment is not energized during the tests.*

*When verifying CLEARANCES, the values for test voltages given in 6.7 apply to tests performed at 2 000 m. For other test site altitudes, the corrections of Table 10 are applied for CLEARANCES but not for tests of solid insulation.*

*NOTE 2 The electric testing of CLEARANCES will also stress the associated solid insulation.*

*NOTE 2—Where two or more protective means are used in combination (see 6.5.1), the voltages specified for REINFORCED INSULATION might be applied to parts of circuits which are not required to withstand these voltages. To test the complete equipment appropriately it may be necessary to test subassemblies separately.*

**Table 10 – Correction factors according to test site altitude for test voltages for CLEARANCES**

Test voltage peak	Correction factors			
	≥ 327 V < 600 V	≥ 600 V < 3 500 V	≥ 3 500 V < 25 kV	≥ 25 kV
Test voltage r.m.s.	≥ 231 V < 424 V	≥ 424 V < 2 475 V	≥ 2 475 V < 17,7 kV	≥ 17,7 kV
Test site altitude m				
0	1,08	1,16	1,22	1,24
500	1,06	1,12	1,16	1,17
1 000	1,04	1,08	1,11	1,12
2 000	1,00	1,00	1,00	1,00
3 000	0,96	0,92	0,89	0,88
4 000	0,92	0,85	0,80	0,79
5 000	0,88	0,78	0,71	0,70
Linear interpolation is allowed.				

### 6.8.2 Humidity preconditioning

*Unless otherwise specified in this Technical Specification, the equipment is subjected to humidity preconditioning before the voltage tests. The equipment is not energized during preconditioning.*

*This treatment need not be applied to parts that are clearly unlikely to be influenced by humidity and temperature.*

*Parts which can be removed without the use of a TOOL are removed and subjected to humidity preconditioning together with the main part.*

*Preconditioning is carried out in a humidity chamber containing air with a humidity of 93 % RH ± 3 % RH. The temperature of the air in the chamber is maintained at 40 °C ± 2 °C.*

*Before applying humidity, the equipment is brought to a temperature of 42 °C ± 2 °C, normally by keeping it at this temperature for at least 4 h before the humidity preconditioning.*

*The air in the chamber is stirred and the chamber is designed so that condensation will not precipitate on the equipment.*

*The equipment remains in the chamber for 48 h, after which it is removed and allowed a recovery period of 2 h under the environmental conditions of 4.3.1, with the covers of non-ventilated equipment removed.*



*The tests are performed and completed within 1 h of the end of the recovery period after humidity preconditioning. Parts that have been removed are re-assembled or not, whichever is less favourable.*

### **6.8.3 Test procedures**

#### **6.8.3.1 The a.c. voltage test**

*The generator shall be able to supply a power of at least 500 VA. The waveform of the power frequency test voltage shall be substantially sinusoidal. This requirement is fulfilled if the ratio between the peak value and the r.m.s. value is  $\sqrt{2} \pm 3\%$ .*

*The test voltage is raised uniformly from 0 V to the specified value within 5 s and held at that value for at least the specified time.*

*No flashover of CLEARANCES or breakdown of solid insulation shall occur during the test.*

#### **6.8.3.2 The 1 min d.c. voltage test**

*The d.c. test voltage shall be substantially free of ripple. This requirement is fulfilled if the ratio between the peak value of the voltage and the average value is  $1,0 \pm 3\%$ .*

*The d.c. test voltage is raised uniformly from 0 V to the specified value within 5 s and held at that value for at least 1 min.*

*No flashover of CLEARANCES or breakdown of solid insulation shall occur during the test.*

#### **6.8.3.3 The impulse voltage withstand test**

*The test shall be conducted for five impulses of each polarity with an interval of at least 1 s between impulses. The impulse voltage test is carried out with a 1,2/50  $\mu$ s waveform (see Figure 1 of IEC 61180-1:1992). The wave shape of each impulse shall be observed (see Note 4).*

*When verifying CLEARANCES within equipment by an impulse voltage test, it is necessary to ensure that the specified impulse voltage appears at the CLEARANCE. PROTECTIVE IMPEDANCE and voltage-limiting devices in parallel with the insulation to be tested shall be disconnected.*

*No flashover of CLEARANCES or breakdown of solid insulation shall occur during the test, but partial discharges are allowed. Partial discharge will be indicated by a step in the resulting wave shape which will occur earlier in successive impulses. Breakdown on the first impulse may either indicate a complete failure of the insulation system or the operation of overvoltage limiting devices in the equipment.*

*NOTE 1 ~~If there are overvoltage limiting devices in the equipment, care must be taken to examine the wave shape to ensure that operation of the overvoltage limiting device is not taken to indicate insulation failure. If the equipment includes overvoltage limiting devices, the wave shape shall be examined to ensure that operation of the overvoltage limiting device has not occurred during the test.~~ Distortions of the impulse voltage which do not change from impulse to impulse may be caused by operation of an overvoltage limiting device and do not indicate a (partial) breakdown of solid insulation.*

*NOTE Partial discharges in voids can lead to ~~cause repetitive~~ partial notches of extremely short durations in the wave shape which may be repeated in the course of an impulse.*

## **6.9 Constructional requirements for protection against electric shock**

### **6.9.1 General**

If a failure could cause a HAZARD:

- a) the security of wiring connections subject to mechanical stresses shall not depend on soldering;
- b) screws securing removable covers shall be captive if their length determines a CLEARANCE or CREEPAGE DISTANCE between ACCESSIBLE conductive parts and HAZARDOUS LIVE parts;
- c) accidental loosening or freeing of the wiring, screws, etc., shall not cause ACCESSIBLE parts to become HAZARDOUS LIVE;
- d) CLEARANCES and CREEPAGE DISTANCES between the ENCLOSURE and HAZARDOUS LIVE parts shall not be reduced below the values for BASIC INSULATION by loosening of parts or wires.

NOTE Screws or nuts with lock washers are not regarded as likely to become loose, nor are wires which are mechanically secured by more than soldering alone.

*Conformity is checked by inspection and by measurement of CLEARANCES and CREEPAGE DISTANCES.*

### **6.9.2 Insulating materials**

The following shall not be used as insulation for safety purposes:

- a) materials which can easily be damaged (for example, lacquer, enamel, oxides, anodic films);
- b) non-impregnated hygroscopic materials (for example, paper, fibres, fibrous materials).

*Conformity is checked by inspection.*

### **6.9.3 Colour coding**

Green-and-yellow insulation shall not be used except for:

- a) protective earth conductors;
- b) PROTECTIVE BONDING conductors;
- c) potential equalization conductors for safety purposes;
- d) functional earth conductors.

*Conformity is checked by inspection.*

## **6.10 Connection to the MAINS supply source and connections between parts of equipment**

### **6.10.1 MAINS supply cords**

The following requirements apply to non-detachable MAINS supply cords and to detachable MAINS supply cords supplied with the equipment.

Cords shall be RATED for the maximum current for the equipment and the cable used shall meet the requirements of IEC 60227-1 or IEC 60245-1. Cords certified or approved by a recognized testing authority are regarded as meeting this requirement.

If a cord is likely to contact hot external parts of the equipment, it shall be made of suitably heat-resistant material.

If the cord is detachable, both the cord and the appliance inlet shall have adequate temperature RATINGS.

Conductors coloured green-and-yellow shall be used only for connection to PROTECTIVE CONDUCTOR TERMINALS.

Detachable MAINS supply cords with MAINS connectors according to IEC 60320 shall either meet the requirements of IEC 60799, or shall be RATED at least for the current RATING of the MAINS connector fitted to the cord.

Figure 9 explains the terminology for MAINS supply cords.

*Conformity is checked by inspection and, where necessary, by measurement.*

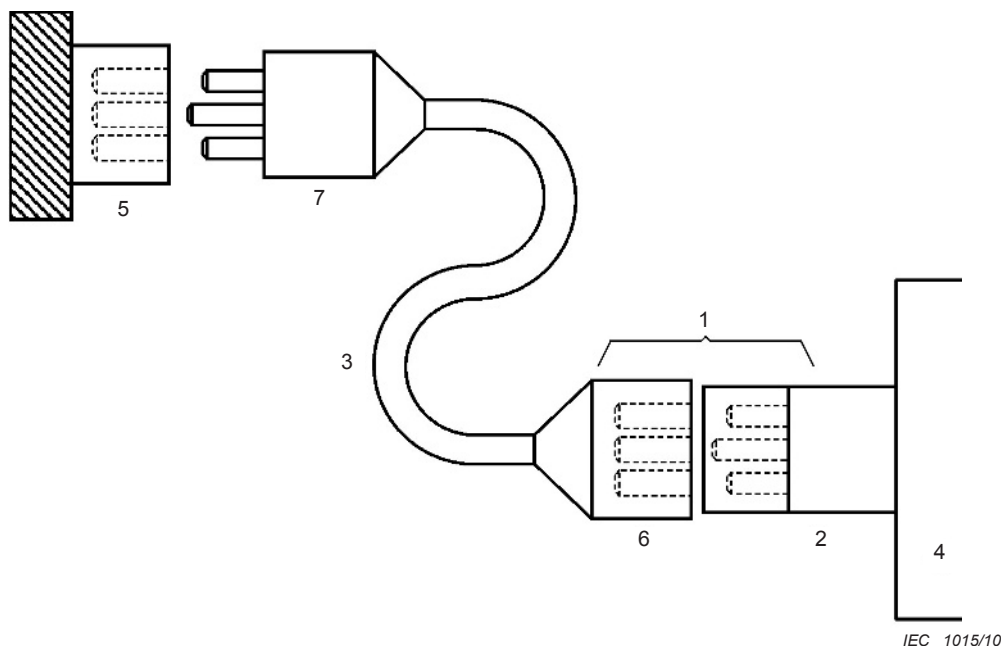

**Key**

- |   |                   |   |                           |
|---|-------------------|---|---------------------------|
| 1 | Appliance coupler | 5 | Fixed mains socket-outlet |
| 2 | Appliance inlet   | 6 | Mains connector           |
| 3 | Cable             | 7 | Mains plug                |
| 4 | Equipment         |   |                           |

**Figure 9 – Detachable MAINS supply cords and connections**

**6.10.2 Fitting of non-detachable MAINS supply cords**

**6.10.2.1 Cord entry**

MAINS supply cords shall be protected against abrasion and sharp bends at the point where the cord enters the equipment, by one of the following means:

- a) an inlet or bushing with a smoothly rounded opening;
- b) a reliably fixed flexible cord guard made of insulating material protruding beyond the inlet opening by at least five times the overall diameter of a cord with the largest cross-sectional area which can be fitted. For flat cords, the larger cross-sectional dimension is taken as the overall diameter.

*Conformity is by inspection, and if needed by measurement of dimensions.*

**6.10.2.2 Cord anchorage**

The cord anchorage shall relieve the conductors of the cord from strain, including twisting, where they are connected within the equipment, and shall protect the insulation of the conductors from abrasion. The protective earth conductor, if any, shall be the last to take the strain if the cord slips in its anchorage.

Cord anchorages shall meet the following requirements:

- a) the cord shall not be clamped by a screw which bears directly on the cord;
- b) knots in the cord shall not be used;
- c) it shall not be possible to push the cord into the equipment to an extent which could cause a HAZARD;
- d) failure of the cord insulation in a cord anchorage which has metal parts shall not cause ACCESSIBLE conductive parts to become HAZARDOUS LIVE.
- e) it shall not be possible to loosen the cord anchorage without the use of a TOOL.
- f) it shall be designed so that cord replacement does not cause a HAZARD, and it shall be clear how the relief from strain is provided.

A compression bushing shall not be used as a cord anchorage unless it is suitable for use with the MAINS supply cord supplied with it or specified for it by the manufacturer.

*Conformity is checked by inspection and by the following push-pull test:*

*For each combination of cord and bushing, the cord is pushed into the equipment manually, as far as possible. It is then subjected 25 times to a steady pull of the value shown in Table 11, applied for 1 s each time in the least favourable direction. Immediately afterwards it is subjected for 1 min to a torque of the value shown in Table 11. The torque shall be applied as close as possible to the external end of the cord anchorage or bushing.*

**Table 11 – Values for physical tests on cord anchorages**

Mass of equipment kg	Force for pull test N	Torque for torque test N·m
≤ 1	30	0,10
> 1 ≤ 4	60	0,25
> 4	100	0,35

*After the tests:*

- 1) *the cord shall not have been damaged;*
- 2) *the cord shall not have been displaced longitudinally by more than 2 mm;*
- 3) *there shall be no signs of strain at the point where the anchorage clamps the cord;*
- 4) *CLEARANCES and CREEPAGE DISTANCES shall not have been reduced below the applicable values;*
- 5) *the cord shall pass the a.c. voltage test of 6.8.3.1 (without humidity preconditioning) with a duration of at least 1 min as follows:*
  - i) *for equipment with a protective earth conductor, the test is made between the protective conductor and the line and neutral conductors joined together, with the test voltage from Table 5 or Table K.8 for BASIC INSULATION for the appropriate line-to-neutral voltage;*
  - ii) *for equipment without a protective earth conductor, the test is made between ACCESSIBLE conductive parts of the equipment and the line and neutral conductors joined together, with the test voltage from Table 5 or Table K.8 for REINFORCED INSULATION for the appropriate line-to-neutral voltage.*

### 6.10.3 Plugs and connectors

Plugs and connectors for connecting equipment to the MAINS supply, including appliance couplers used to connect detachable MAINS supply cords, shall conform to the relevant specifications for plugs, socket-outlets and connectors.

If the equipment is designed to be supplied only at voltages below the level of 6.3.2 a) in NORMAL CONDITION or SINGLE FAULT CONDITION, or from a source used solely to supply that equipment, the plugs of the power supply cord shall not fit into the socket-outlets of MAINS supply systems at voltages above the RATED supply voltage of the equipment. MAINS-type plugs and sockets shall not be used for purposes other than connection of a MAINS supply.

If plug pins of cord-connected equipment receive a charge from an internal capacitor, the pins shall not be HAZARDOUS LIVE 5 s after disconnection of the supply.

On equipment with accessory MAINS socket-outlets:

- a) if the outlet can accept a standard MAINS supply plug, there shall be a marking as specified in 5.1.3 e);
- b) if the outlet has a TERMINAL contact for a protective earth conductor, the input MAINS supply connection to the equipment shall include a protective earth conductor connected to a PROTECTIVE CONDUCTOR TERMINAL.

*Conformity is checked by inspection. For plugs receiving a charge from an internal capacitor, the measurements of 6.3 are made to establish that the levels of 6.3.1 c) are not exceeded.*

## 6.11 Disconnection from supply source

### 6.11.1 General

Except as specified in 6.11.2, equipment shall be provided with a means for disconnecting it from each electrical supply source, whether external or internal to the equipment. The disconnecting means shall disconnect all current-carrying conductors.

NOTE Equipment can also be provided with a switch or other disconnecting device for functional purposes.

*Conformity is checked as specified in 6.11.3.1 to 6.11.4.3.*

### 6.11.2 Exceptions

A disconnecting device is not required if a short circuit or overload cannot cause a HAZARD.

NOTE Examples include:

- a) equipment intended for supply only from a low energy source such as a small battery or signal powered equipment;
- b) equipment intended only for connection to an impedance protected supply. Such a supply is one having an impedance of such value that, if the equipment is subjected to an overload or short circuit, the RATED supply conditions are not exceeded and no HAZARD can arise;
- c) equipment which constitutes an impedance protected load. Such a load is a component without discrete overcurrent or thermal protection, and of such impedance that the RATING is not exceeded if the circuit of which the component is a part is subjected to an overload or short circuit.

*Conformity is checked by inspection. In case of doubt, a short circuit or overload is applied to check that no HAZARD can arise.*

### 6.11.3 Requirements according to type of equipment

#### 6.11.3.1 PERMANENTLY CONNECTED EQUIPMENT and multi-phase equipment

PERMANENTLY CONNECTED EQUIPMENT and multi-phase equipment shall employ a switch or circuit-breaker as the means for disconnection.

If a switch is not part of the equipment, documentation for equipment installation shall specify that:

- a) a switch or circuit-breaker must be included in the installation;
- b) it must be suitably located and easily reached;
- c) it must be marked as the disconnecting device for the equipment.

*Conformity is checked by inspection.*

### **6.11.3.2 Single-phase cord-connected equipment**

Single-phase cord-connected equipment shall have one of the following as a disconnecting device:

- a) a switch or circuit-breaker;
- b) an appliance coupler which can be disconnected without the use of a TOOL;
- c) a separable plug, without a locking device, to mate with a socket-outlet in the building.

*Conformity is checked by inspection.*

## **6.11.4 Disconnecting devices**

### **6.11.4.1 General**

If a disconnecting device is part of the equipment, it shall be located electrically as close as practicable to the supply. Power-consuming components shall not be electrically located between the supply source and the disconnecting device, except that electromagnetic interference suppression circuits are permitted to be located on the supply side of the disconnecting device.

*Conformity is checked by inspection.*

### **6.11.4.2 Switches and circuit-breakers**

An equipment switch or circuit-breaker employed as a disconnecting device shall meet the relevant requirements of IEC 60947-1 and IEC 60947-3 and be suitable for the application.

If a switch or a circuit-breaker is used as a disconnecting device, it shall be marked to indicate this function. If there is only one device – one switch or one circuit-breaker – symbols 9 and 10 of Table 1 are sufficient.

A switch shall not be incorporated in a MAINS supply cord.

A switch or circuit-breaker shall not interrupt a protective earth conductor.

*Conformity is checked by inspection.*

### **6.11.4.3 Appliance couplers and plugs**

If an appliance coupler or separable plug is used as the disconnecting device, it shall be readily identifiable and easily reached by the OPERATOR. ~~For single-phase PORTABLE EQUIPMENT, a plug on a cord of length not greater than 3 m is considered to be easily reached. The protective earth conductor of an appliance coupler shall be connected before the supply conductors and disconnected after them.~~

For single-phase PORTABLE EQUIPMENT, a plug on a cord of length not greater than 3 m for an OPERATOR or a STUDENT OPERATOR aged 11 years and above or 2 m for a STUDENT OPERATOR under 11 years is considered to be easily reached. For a STUDENT OPERATOR under 11 years a

3 m cord may be used provided that it can be clamped to the equipment in such a way that the STUDENT OPERATOR can still reach the plug. The protective earth conductor of an appliance coupler shall be connected before the supply conductors and disconnected after them.

*Conformity is checked by inspection.*

## **7 Protection against mechanical HAZARDS**

### **7.1 General**

The equipment shall not cause a mechanical HAZARD in NORMAL USE, or cause a HAZARD in a SINGLE-FAULT CONDITION that might not be easily noticed. Mechanical HAZARDS include, but are not limited to, the following:

- a) sharp edges which could cause cuts (see 7.2);
- b) moving parts that could crush body parts or penetrate the skin (see 7.3);
- c) unstable equipment that could fall on a person while in use or while being moved (see 7.4);
- d) falling equipment, resulting from breakage of the carrying device (see 7.5), wall mounting bracket (see 7.6) or other support part (see 7.5); and
- e) expelled parts from the equipment (see 7.7).

NOTE If the equipment consists of two or more units, the value of the mass refers to the mass of each individual unit. However, if one or more units are intended to be attached to or supported by another unit, these units are treated as a single unit.

*Conformity is checked as specified in 7.2 to 7.7.*

### **7.2 Sharp edges**

All easily-touched parts of the equipment shall be smooth and rounded so as not to cause injury during NORMAL USE of the equipment.

Unless the fault presents an obvious HAZARD, easily-touched parts of the equipment shall not cause an injury in SINGLE FAULT CONDITION.

*Conformity is checked by inspection and, if necessary, by application of an object that represents a finger in size, shape and hardness, to check for abrasions or cuts.*

NOTE An acceptable procedure is outlined in UL 1439.

### **7.3 Moving parts**

#### **7.3.1 General**

HAZARDS from moving parts shall not exceed a tolerable level except as specified in 7.3.2. The conditions specified in 0 and 7.3.5 are considered to represent a tolerable level. If these conditions are not met, a RISK assessment shall be carried out according to 7.3.3 or Clause 17.

NOTE In this context moving parts mean parts that are driven by an energy source other than directly applied human or animal effort.

*Conformity is checked as specified in 7.3.2, 7.3.3, 7.3.4, 7.3.5 and Clause 17 as applicable.*

#### **7.3.2 Exceptions**

If it is not feasible for operating reasons to prevent certain moving parts from causing a potential HAZARD, access is permitted in the following circumstances.



- a) Equipment with easily-touched moving parts which are obviously intended to operate on parts or materials external to the equipment, for example drilling and mixing equipment, shall be designed to minimize inadvertent touching of these moving parts (for example, by guards or handles).
- b) If, during routine maintenance outside NORMAL USE, it is unavoidable for technical reasons for an OPERATOR to perform a function which requires access to moving parts that could cause a HAZARD, access is permitted if all of the following precautions have been taken:
  - 1) access is not possible without the use of a TOOL;
  - 2) the instructions for the RESPONSIBLE BODY include a statement that OPERATORS must be trained before being allowed to perform the hazardous operation and that STUDENT OPERATORS should not perform routine maintenance outside NORMAL USE;
  - 3) there are warning markings on covers or parts which have to be removed to obtain access, prohibiting access by untrained OPERATORS. As an alternative, symbol 14 of Table 1 shall be placed on the covers or parts, with the warnings included in the documentation.

*Conformity is checked by inspection.*

### 7.3.3 Risk assessment for mechanical HAZARDS to body parts

RISKS shall be reduced to a tolerable level by at least the applicable minimum protective measure of Table 12, taking into account the severity, probability of exposure and possibility of avoiding the HAZARD.

*Conformity is checked by evaluation of the RISK assessment documentation to ensure that the RISKS have been eliminated or that only TOLERABLE RISKS remain.*

**Table 12 – Protective measures against mechanical HAZARDS to body parts**

Mechanical HAZARD conditions			Minimum protective measures
Severity <sup>a</sup>	Probability of exposure <sup>b</sup>	Possibility of avoiding the HAZARD <sup>c</sup>	
S	E <sub>2</sub>	P <sub>2</sub>	C
S	E <sub>2</sub>	P <sub>1</sub>	C
S	E <sub>1</sub>	P <sub>2</sub>	C
S	E <sub>1</sub>	P <sub>1</sub>	B
M	E <sub>2</sub>	P <sub>2</sub>	B
M	E <sub>2</sub>	P <sub>1</sub>	A
M	E <sub>1</sub>	P <sub>2</sub>	A
M	E <sub>1</sub>	P <sub>1</sub>	No action



**a Severity:**

M = Moderate HAZARDS, sufficient to bruise or scratch a body part.

S = Serious HAZARDS, sufficient to break bones or dismember a body part.

**b Probability of exposure:**

E<sub>1</sub> = Exposure is not intended during NORMAL USE.

E<sub>2</sub> = Exposure is intended during NORMAL USE.

**c Possibility of avoiding the HAZARD:**

P<sub>1</sub> = Possibility of avoidance:

The motion is visible and velocity is low enough for body parts to be removed without being trapped, or an audible or visible alarm is activated before body parts can be trapped.

P<sub>2</sub> = No possibility of avoidance:

Conditions other than P1.

**d Minimum protective measures:**

A = Low level measures; warning markings, audible or visual signals or instructions for use.

B = Moderate measures; emergency switches, PROTECTIVE BARRIERS or covers removable only with a TOOL, distances (see ISO 43852 13857), or separation (see ISO 13854 or EN 349).

C = Stringent measures; interlocks, PROTECTIVE BARRIERS or covers removable only with a TOOL and with instructions to disconnect from the power source.

### 7.3.4 Limitation of force and pressure

The physical levels specified below are not considered to be hazardous. They are based on a combination of contact force, duration and contact area. The levels below shall be met in NORMAL CONDITION and SINGLE-FAULT CONDITION.

The maximum tolerable continuous contact pressure is 50 N/cm<sup>2</sup>, with a maximum force of 150 N.

The maximum tolerable temporary force for body contact areas of at least 3 cm<sup>2</sup> is 250 N for a maximum duration of 0,75 s. The measurement of this force is made with a force gauge which has a spring ratio of at least 25 N/mm.

*Conformity is checked by inspection and, in case of doubt, by measurement.*

### 7.3.5 Gap limitations between moving parts

#### 7.3.5.1 Gap limitations between moving parts – Access normally allowed

If the force and pressure of the moving parts exceed the limits of 7.3.4 and if a body part could be inserted between moving parts, the width of the gap shall not decrease from a value larger than the minimum gap of Table 13 for that body part to a value smaller than the minimum gap in NORMAL CONDITION and SINGLE-FAULT CONDITION.

*Conformity is checked by inspection and, in case of doubt, by measurement.*

#### 7.3.5.2 Gap limitations between moving parts – Access normally prevented

~~While parts are moving, gaps between moving parts into which body parts could be inserted shall not increase to more than the acceptable gap of Table 14, in NORMAL CONDITION and SINGLE-FAULT CONDITION.~~





While parts are moving, gaps between moving parts into which body parts could be inserted shall:

- a) not increase to more than the acceptable gap of Table 14 for STUDENT OPERATORS aged 14 years and above in NORMAL CONDITION and SINGLE-FAULT CONDITION, and
- b) conform to ISO 13857:2008, 4.2.2.2 and 4.2.4.3 for STUDENT OPERATORS aged 3 years and above in NORMAL CONDITION and SINGLE-FAULT CONDITION.

Equipment with lower limb access to moving parts shall have a warning marking to indicate that STUDENT OPERATORS aged below 14 years are not permitted to use the equipment, unless a RISK assessment has been completed in accordance with Clause 17. See 5.2.

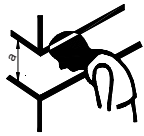
*Conformity is checked by inspection and, in case of doubt, by measurement.*

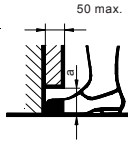
**Table 13 – Minimum maintained gaps to prevent crushing for different body parts**

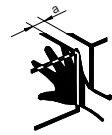
Part of body	Minimum gap (a) to avoid crushing mm	Illustration
Torso	500	
Head	300	
Leg	180	
Foot	120	
Toes	50	
Arm	120	
Hand, wrist, fist	100	

Part of body	Minimum gap (a) to avoid crushing mm	Illustration
Finger	25	
The values in this table are for adults. For equipment that may be operated by children or youths, consideration should be given to smaller dimensions.		

**Table 14 – Maximum gaps to prevent access for different body parts**

Part of body	Maximum gap (a) <sup>a</sup> to prevent access mm
Head	120
Foot	35
Finger	4
NOTE-The values in this table are for adults. For equipment that may be operated by <u>CHILDREN</u> or youths, consideration should be given to smaller dimensions.	
<sup>a</sup> See Table 13 for examples of gap (a).	

#### 7.4 Stability

Equipment and assemblies of equipment not secured to the building structure before operation shall be physically stable.

If means are provided to ensure that stability is maintained after the opening of drawers, etc. by an OPERATOR, either these means shall be automatic or there shall be a warning marking to apply the means.

Each castor and support foot shall be RATED to support a load of at least 4 times its normal load, or the castors and support feet shall be tested according to d) and e), below.

*Conformity is checked by inspection and by carrying out each of the following tests, if applicable, to ensure that the equipment will not overbalance. Containers contain the RATED amount of substance which provides the least favourable conditions of NORMAL USE. Castors are in their least favourable position of NORMAL USE. Doors, drawers, etc. are closed unless otherwise specified below.*

- a) *Equipment other than HAND-HELD EQUIPMENT is tilted in each direction to an angle of 10° from its normal position.*
- b) *Equipment which has both a height of 1 m or more and a mass of 25 kg or more, and all floor-standing equipment, has a force applied at its top, or at a height of 2 m if the equipment has a height of more than 2 m. The force is 250 N, or 20 % of the weight of the equipment, whichever is less, and is applied to all surfaces in directions which could cause the equipment to topple. Stabilizers used in NORMAL USE, and doors, drawers, etc., intended to be opened by an OPERATOR, are in their least favourable positions.*
- c) *Floor-standing equipment has a force of 800 N applied downwards at the point of maximum moment to:*
  - 1) *all horizontal working surfaces;*
  - 2) *other surfaces providing an obvious ledge and which are not more than 1 m above floor level.*

*Doors, drawers, etc. are closed, except that those intended to be opened by an OPERATOR are in their least favourable positions.*

- d) *The castor or support foot that supports the greatest load (M) is loaded with 4 times that load (4 x M).*
- e) *The castor or support foot that supports the greatest load is removed from the equipment and the equipment is placed on a flat surface.*

*NOTE 1—During this test, the unit should be secured so that complete overturning is not possible if this could present a HAZARD to those conducting the test. However, this restraint must not interfere with the determination of whether the unit would overbalance. If, during this test, complete overturning would present a HAZARD to those conducting the test the unit should be secured so that complete overturning is not possible, in such a manner that the restraint does not interfere with the determination of whether the unit would overbalance.*

*NOTE 2—The supporting block should be removed from a distance so that the unit cannot cause a HAZARD during the test.*

## **7.5 Provisions for lifting and carrying**

### **7.5.1 General**

Equipment or parts having a mass of 18 kg or more shall be provided with a means for lifting and carrying, or directions shall be given in the documentation.

*Conformity is checked as specified in 7.5.2 and 7.5.3.*

### **7.5.2 Handles and grips**

*If carrying handles or grips are fitted to the equipment, or supplied with it, they shall be capable of withstanding a force of four times the weight of the equipment.*

*Conformity is checked by inspection and by the following test.*

*A single handle or grip is subjected to a force corresponding to four times the weight of the equipment. Unless the handle mounting screws (if any) are secured against loosening, one screw is removed before performing these tests. The force is applied uniformly over a 70 mm width at the centre of the handle or grip, without clamping. The force is steadily increased so that the test value is attained after 10 s and maintained for a period of 1 min.*

*If more than one handle or grip is fitted, the force is distributed between the handles or grips in the same proportion as in NORMAL USE. If the equipment is fitted with more than one handle or grip but is so designed that it may readily be carried by only one handle or grip, the total force is applied to each handle or grip.*

*After the tests the handles or grips shall not have broken loose from the equipment and there shall not be any permanent distortion, cracking or other evidence of failure which could cause a HAZARD.*

### **7.5.3 Lifting devices and supporting parts**

Parts of lifting devices and parts that support heavy loads shall be RATED for the maximum load or shall be tested to withstand four times the maximum static load.

*Conformity is checked by inspection of the RATINGS of the parts, or by the following test:*

*A total load equal to four times the maximum load is placed at the least favourable position of a RATED load in NORMAL USE.*

*During the test, no part of a lifting device or a load support shall break or deform to an extent that could cause a HAZARD.*

## 7.6 Wall mounting

Mounting brackets on equipment intended to be mounted on a wall or ceiling shall withstand a force of four times the weight of the equipment.

*Conformity is checked after mounting the equipment in accordance with the manufacturer's instructions, using the fasteners and wall construction specified. Adjustable brackets are adjusted to the position that will give the maximum projection from the wall.*

*If no wall construction is specified, a 12 mm ± 2 mm thick plasterboard (drywall) on nominal 50 mm × 100 mm ± 10 mm studs at 400 mm ± 10 mm centres is used as the support surface. Fasteners are applied as specified in the installation documentation or, if not specified, are positioned in the plasterboard between the studs.*

*The mounting brackets are then subjected to a weight equal to four times the weight of the equipment, acting vertically through the centre of gravity. The test weight is applied gradually and is increased from zero to full load in 5 s to 10 s, then maintained for 1 min.*

*If more than one fastener is specified for mounting a bracket, then one fastener is removed and the test is repeated with a weight equal to two times the weight of the equipment.*

*After the tests, there shall be no damage to the bracket or the mounting surface which could cause a HAZARD.*

## 7.7 Expelled parts

Equipment shall contain or limit the energy of parts which could cause a HAZARD if expelled in the event of a fault.

The means of protection against expelled parts shall not be removable without the aid of a TOOL.

NOTE Clause 8 does not address HAZARDS from parts that could be expelled from inside the equipment.

*Conformity is checked by inspection after application of the relevant fault conditions of 4.4.*

## 8 Resistance to mechanical stresses

### 8.1 General

Equipment shall not cause a HAZARD when subjected to mechanical stresses likely to occur in NORMAL USE.

The normal energy protection level required is 5 J. Levels below 5 J but not less than 1 J are permitted provided that all the following criteria are met:

- a) the lower level is justified by a RISK assessment carried out by the manufacturer (see Clause 17);
- b) when the equipment is installed in its intended application it cannot easily be touched by unauthorized persons or the general public;
- c) in NORMAL USE, the equipment is only accessed for occasional operations such as adjustment, programming or maintenance;
- d) the equipment is marked with an IK code in accordance with IEC 62262 or with symbol 14 of Table 1, and the RATED energy level and test method are stated in the accompanying documentation. For non-metallic ENCLOSURES with a minimum RATED ambient temperature below 2 °C, the stated value shall be that applicable to the lowest RATED ambient

temperature. If impact energies used are between IK values of IEC 62262, any IK marking shall be for the nearest lower value.

*Conformity is checked by inspection and by performing each of the following tests on the ENCLOSURE as applicable:*

- 1) *the static test of 8.2.1;*
- 2) *for equipment other than HAND-HELD EQUIPMENT and DIRECT PLUG-IN EQUIPMENT, the impact test of 8.2.2 at the energy level specified above. If the specified energy level is not 5 J the test of IEC 62262 is an alternative to the impact test of 8.2.2, using test Eha (pendulum test) or test Ehc (vertical hammer) described in IEC 60068-2-75;*
- 3) *except for FIXED EQUIPMENT and equipment with a mass over 100 kg, the test of 8.3.1 or 8.3.2, as applicable. The equipment is not operated during the tests;*
- 4) *for PORTABLE EQUIPMENT with a mass up to 5 kg, both the test of 8.2.2 with an energy level of 5 J and the test of 8.3.2.*

*If the same test with the same energy level is required in both items 2) and 4), or in both items 3) and 4), then each test needs to be performed only once.*

*An ENCLOSURE with an impact RATING of at least IK08 by the ENCLOSURE manufacturer, and that would clearly have met the criteria of 8.1 i) to 8.1 vii) after that test, need not be subjected to the test of 8.2.2.*

*Parts which do not form part of an ENCLOSURE are not subjected to the tests of 8.2.1 and 8.2.2.*

*After the tests, visibly damaged windows and displays shall be inspected to check that HAZARDOUS LIVE parts exceeding the values of 6.3.2 have not become ACCESSIBLE, and insulation of all other parts of the ENCLOSURE which could have been affected by the tests shall pass the voltage tests of 6.8 (without humidity preconditioning) applicable to the type of insulation (see 6.7). In addition the equipment is inspected to check that:*

- i) there have been no leaks of corrosive or harmful substances;*
- ii) ENCLOSURES show no cracks which could cause a HAZARD;*
- iii) CLEARANCES are not less than their permitted values;*
- iv) the insulation of internal wiring remains undamaged;*
- v) PROTECTIVE BARRIERS necessary for safety have not been damaged or loosened;*
- vi) no moving parts are exposed, except as permitted by 7.3;*
- vii) there has been no damage which could cause spread of fire.*

## **8.2 ENCLOSURE rigidity tests**

### **8.2.1 Static test**

*The equipment is held firmly against a rigid support and subjected to a force of 30 N applied by the hemispherical end of a hard rod of 12 mm diameter. The rod is applied to each part of the ENCLOSURE which could easily be touched when the equipment is ready for use, including any part of the bottom of PORTABLE EQUIPMENT, and which could cause a HAZARD if distorted.*

*In case of doubt whether a non-metallic ENCLOSURE will pass this test at an elevated temperature, this test is performed after the equipment is operated at an ambient temperature of 40 °C, or the maximum RATED ambient temperature if higher, until a steady-state condition is reached. The equipment is disconnected from the supply source before the test is performed.*

### 8.2.2 Impact test

Bases, covers, etc., intended to be removed and replaced by an OPERATOR have their fixing screws tightened using a torque likely to be applied in NORMAL USE. With the equipment held firmly against a rigid support, the impact is applied to any point on surfaces which are easily touched in NORMAL USE and which would be likely to cause a HAZARD if damaged.

*NOTE* A support is considered to be sufficiently rigid if its displacement is less than or equal to 0,1 mm under the effect of an impact directly applied and whose energy corresponds to the degree of protection.

Non-metallic ENCLOSURES of equipment with a minimum RATED ambient temperature below 2 °C are cooled to the minimum RATED ambient temperature, then tested within 10 min.

Impacts may be applied to empty ENCLOSURES if it is clear that the equipment would have passed the test if it had been tested in complete condition.

If an ENCLOSURE is damaged by an impact but meets the pass criteria, a new ENCLOSURE may be used for the next impact.

FIXED EQUIPMENT is mounted as specified in the installation instructions. Other equipment is held firmly against a rigid support and each test point is subjected to one impact by a smooth steel sphere with a mass  $500\text{ g} \pm 25\text{ g}$  and with a diameter of approximately 50 mm.

The impact test can be performed with the equipment mounted at 90° to its normal position to allow both the method of Figure 10 a) and Figure 10 b).

Figure 10 a) shows the impact applied to a horizontal surface, with the sphere allowed to fall freely from a height of X.

Figure 10 b) shows the impact applied to a vertical surface, with the sphere suspended by a cord and allowed to fall as a pendulum through a vertical distance of X.

In both cases the dimension X is determined from Table 15 according to the energy level to be applied.

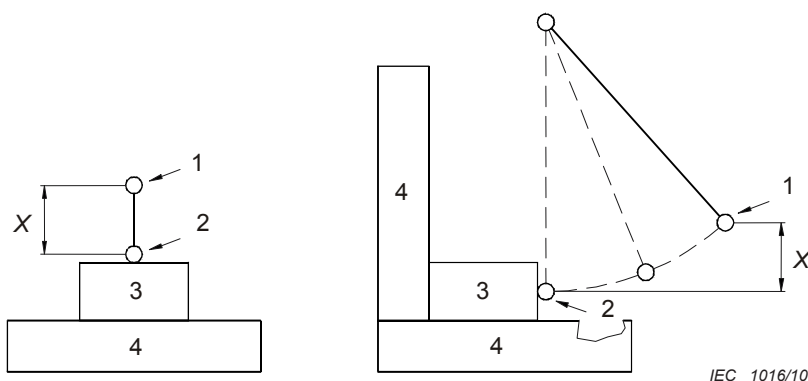

Figure 10 a) Impact applied to a horizontal surface

Figure 10 b) Impact applied to a vertical surface

**Key**

- |   |   |   |                          |
|---|---|---|--------------------------|
| 1 | Sphere start position                                 | 2 | Sphere impact position   |
| 3 | Test sample   | 4 | Rigid supporting surface |
| X | Vertical fall distance. See Table 15 for values of X. |   |                          |

**Figure 10 – Impact test using a sphere**



**Table 15 – Impact energy levels, test height and corresponding IK codes**

	Impact energy level J and IK Code		
	1 (IK06)	2 (IK07)	5 (IK08)
Vertical fall distance (X) mm	200	400	1 000

### 8.3 Drop test

#### 8.3.1 Equipment other than HAND-HELD EQUIPMENT and DIRECT PLUG-IN EQUIPMENT

*The equipment is placed in its position of NORMAL USE on a smooth, hard rigid surface of concrete or steel. It is then tilted about each bottom edge in turn so that the distance between the opposite edge and the test surface is 100 mm for equipment up to 20 kg, 25 mm for equipment between 20 kg and 100 kg, or so that the angle made by the bottom and test surface is 30°, whichever is less severe. It is then allowed to fall freely onto the test surface.*

*If the number of bottom edges exceeds four, the number of drops shall be limited to four edges.*

*NOTE—If the equipment consists of two or more units, the value for the mass refers to the mass of each individual unit. However, if one or more units are intended to be attached to, or supported by, another unit, these units are treated as a single unit.*

*The method of test shall not allow the equipment to topple onto any other face instead of falling back onto the test face as intended.*

#### 8.3.2 HAND-HELD EQUIPMENT and DIRECT PLUG-IN EQUIPMENT

*The equipment is dropped once through a distance of 1 m onto a 50 mm thick hardwood board having a density of more than 700 kg/m<sup>3</sup> lying flat on a rigid base such as concrete. The equipment is dropped so that it lands in the position expected to present the most severe condition.*

*Non-metallic ENCLOSURES of equipment with a minimum RATED ambient temperature below 2 °C are cooled to the minimum RATED ambient temperature, then tested within 10 min.*

## 9 Protection against the spread of fire

### 9.1 General

There shall be no spread of fire outside the equipment in NORMAL CONDITION or in SINGLE FAULT CONDITION. Figure 11 is a flow chart showing methods of conformity verification.

Equipment energized from a MAINS supply shall also meet the requirements of 9.6.

*Conformity is checked by at least one of the following methods.*

- a) *Testing in the SINGLE FAULT CONDITIONS (see 4.4) that could cause the spread of fire outside the equipment. The conformity criteria of 4.4.4.3 shall be met.*
- b) *Verifying elimination or reduction of the sources of ignition within the equipment as specified in 9.2.*
- c) *Verifying, as specified in 9.3, that if a fire occurs it will be contained within the equipment.*

*These alternative methods can be applied throughout the equipment or individually for different sources of HAZARDS or for different areas of the equipment.*



NOTE 1 Methods b) and c) are based on fulfilling specified design criteria, in contrast to method a) which relies entirely on testing in specified SINGLE FAULT CONDITIONS.

NOTE 2 See 13.2.2 concerning protection against fire caused by batteries.

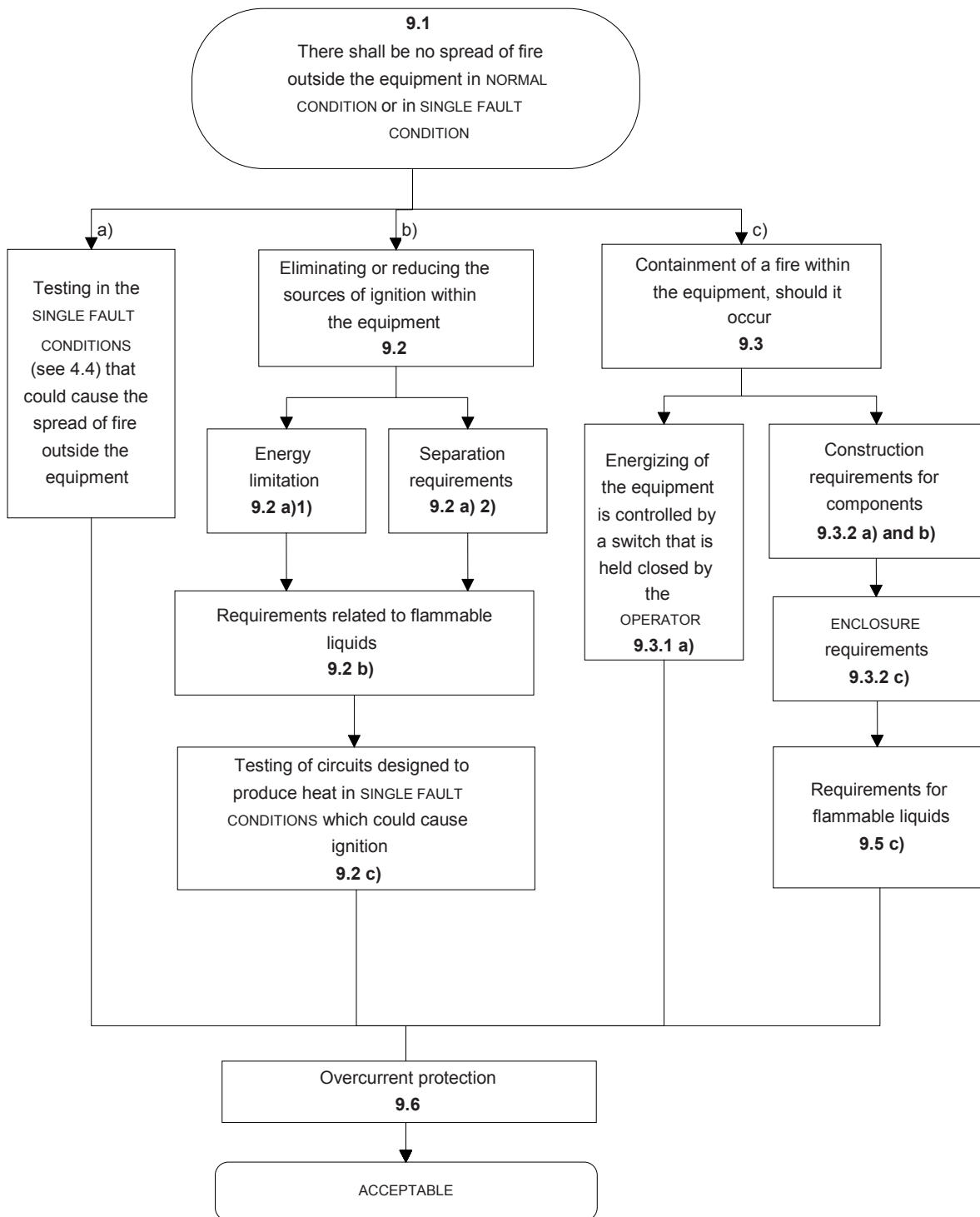

**Figure 11 – Flow chart to explain the requirements for protection against the spread of fire**

## 9.2 Eliminating or reducing the sources of ignition within the equipment

The possibility of ignition and occurrence of fire is considered to be reduced to a tolerable level if all the following requirements a), b) and c), if applicable, are met.

a) Either 1) or 2):

- 1) the voltage, current and power available to the circuit or part of equipment are limited as specified in 9.4;

*Conformity is checked by measurement of limited-energy values as specified in 9.4.*

- 2) insulation between parts at different potentials meets the requirements for BASIC INSULATION, or it can be demonstrated that bridging the insulation will not cause ignition.

*Conformity is checked by inspection and in case of doubt by test.*

b) Any ignition HAZARD related to flammable liquids is reduced to a tolerable level as specified in 9.5.

*Conformity is checked as specified in 9.5.*

c) In circuits designed to produce heat, no ignition occurs when tested in SINGLE FAULT CONDITION (see 4.4).

*Conformity is checked by the relevant tests of 4.4, applying the criteria of 4.4.4.3.*

## 9.3 Containment of fire within the equipment, should it occur

### 9.3.1 General

The possibility of the spread of fire outside the equipment is considered to be reduced to a tolerable level if the equipment meets one of the following constructional requirements:

- a) energizing of the equipment is controlled by a switch that needs to be continuously held in the energized state by the OPERATOR;
- b) the equipment and the equipment ENCLOSURE conform to the constructional requirements of 9.3.2 and the applicable requirements of 9.5 are met.

*Conformity is checked by inspection and as specified in 9.3.2 and 9.5.*

### 9.3.2 Constructional requirements

The following constructional requirements shall be met.

- a) Connectors and insulating material on which components are mounted shall have a flammability classification V-2, or better, of IEC 60695-11-10. See also 14.7 for requirements for printed wiring boards.

NOTE 1 V-0 is better than V-1, which is better than V-2.

*Conformity is checked by inspection of data on materials, and, in case of doubt, by performing the vertical burning test of IEC 60695-11-10 on samples of the material used in the relevant parts.*

- b) Insulated wires and cables shall retard flame propagation.

NOTE 2 Wire with a flammability rating of UL 2556 VW-1 or equivalent is considered to meet this requirement.

*Conformity is checked by inspection of data on materials, and, in case of doubt, by performing whichever of the following tests is applicable:*

- 1) for wires and cables with overall cross-sectional area of the conductors exceeding 0,5 mm<sup>2</sup>, the test of IEC 60332-1-2;
  - 2) for wires and cables with overall cross-sectional area of the conductors of 0,5 mm<sup>2</sup> or less, the test of IEC 60332-2-2.
- c) The ENCLOSURE shall meet the following requirements:
- 1) The bottom and sides of the ENCLOSURE within the 5° arc of Figure 13 of circuits that are not limited circuits according to 9.4 shall comply with one of the following requirements:
    - i) have no openings;
    - ii) be made of metal with perforations as specified in Table 16;
    - iii) be a metal screen with a mesh not exceeding 2 mm × 2 mm centre to centre and a wire diameter of at least 0,45 mm;
    - iv) have openings with baffles according to Figure 12.
  - 2) The ENCLOSURE, and any baffle or flame barrier, shall be made of metal (except magnesium) or of non-metallic materials having a flammability classification of V-1 or better, of IEC 60695-11-10.
  - 3) The ENCLOSURE, and any baffle or flame barrier, shall have adequate rigidity.

*Conformity is checked by inspection. In case of doubt, the flammability classification of requirement c) 2) is checked by performing the vertical burning test of IEC 60695-11-10 on samples of the material used in the relevant parts.*

**Table 16 – Acceptable perforation of the bottom of an ENCLOSURE**

Minimum thickness mm	Maximum diameter of holes mm	Minimum spacing of holes centre to centre mm
0,66	1,14	1,70 (233 holes/645 mm <sup>2</sup> )
0,66	1,19	2,36
0,76	1,15	1,70
0,76	1,19	2,36
0,81	1,91	3,18 (72 holes/645 mm <sup>2</sup> )
0,89	1,90	3,18
0,91	1,60	2,77
0,91	1,98	3,18
1,00	1,60	2,77
1,00	2,00	3,00

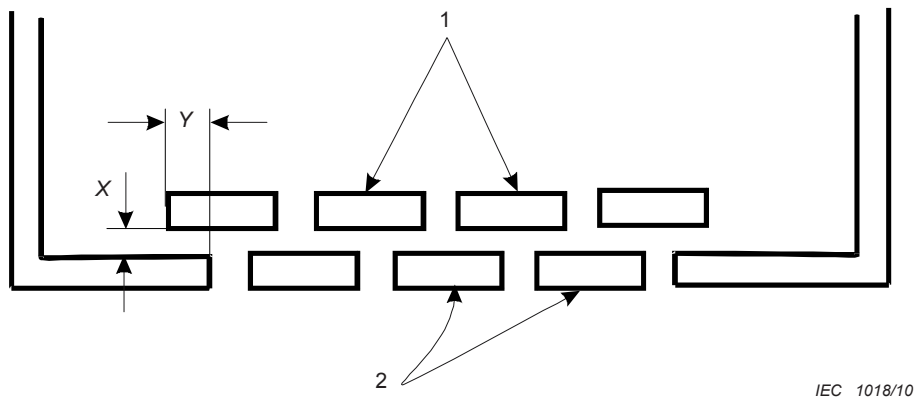

NOTE  $Y \geq$  twice  $X$  but never less than 25 mm

**Key**

- 1 Baffle plates (may be below the bottom of the ENCLOSURE)
- 2 Bottom of ENCLOSURE

**Figure 12 – Baffle**

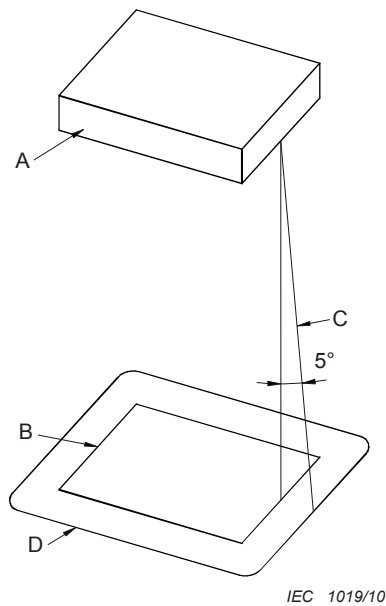

**Key**

- A Part or component of the equipment that is considered to be a source of fire HAZARD. This consists of an entire component or part of the equipment if it is not otherwise shielded, or the unshielded portion of a component that is partially shielded by its casing.
- B Projection of the outline of A on the horizontal plane.
- C Inclined line that traces out the minimum area of the bottom and sides to be constructed as specified in 9.3.2 c) 1) and 9.3.2 c) 2). This line projects at a 5° angle from the vertical at every point around the perimeter of A and is oriented so as to trace out the maximum area.
- D Minimum area of the bottom to be constructed as specified in 9.3.2 c) 1).

**Figure 13 – Area of the bottom of an ENCLOSURE  
 to be constructed as specified in 9.3.2 c) 1)**

#### 9.4 Limited-energy circuit

A limited-energy circuit is a circuit that meets all the following criteria.

- a) The voltage appearing in the circuit is not more than 30 V r.m.s., 42,4 V peak, or 60 V d.c.
- b) The current that can appear in the circuit is limited by one of the following means:
  - 1) the maximum available current is limited inherently or by impedance so that it cannot exceed the applicable value of Table 17;
  - 2) current is limited by an overcurrent protection device so that it cannot exceed the applicable values of Table 18;
  - 3) a regulating network limits the maximum available current so that it cannot exceed the relevant value of Table 17 in NORMAL CONDITION or as a result of a fault in the regulating network.
- c) It is separated by at least BASIC INSULATION from other circuits having energy values exceeding criteria a) and b) above.

If an overcurrent protection device is used, it shall be a fuse or a non-adjustable non-self-resetting electromechanical device.

*Conformity is checked by inspection and by measuring the potentials appearing in the circuit and the maximum available current, under the following conditions:*

- i) the potentials appearing in the circuit are measured in the load condition that maximizes the voltage;*
- ii) output current is measured after 60 s of operation, with the resistive load (including short circuit) which produces the highest value of current.*

**Table 17 – Limits of maximum available current**

Open-circuit output voltage ( $U$ or $\hat{U}$ )			Maximum available current A
V			
a.c. r.m.s.	d.c.	Peak <sup>a</sup>	a.c. r.m.s. or d.c.
$U \leq 2$	$U \leq 2$	$\hat{U} \leq 2,8$	50
$2 < U \leq 12,5$	$2 < U \leq 12,5$	$2,8 < \hat{U} \leq 17,6$	$100 / U$
$12,5 < U \leq 18,7$	$12,5 < U \leq 18,7$	$17,6 < \hat{U} \leq 26,4$	8
$18,7 < U \leq 30$	$18,7 < U \leq 60$	$26,4 < \hat{U} \leq 42,4$	$150 / U$

<sup>a</sup> The peak value ( $\hat{U}$ ) applies to non-sinusoidal a.c. and to d.c. with ripple exceeding 10 %, and is provided for convenience. The r.m.s. value of the maximum available current shall be determined as that value is related to heating.

**Table 18 – Values for overcurrent protection devices**

Potential appearing in the circuit ( $U$ or $\hat{U}$ )			Current that the device breaks after not more than 120 s <sup>b c</sup> A
V			
a.c. r.m.s.	d.c.	Peak <sup>a</sup>	a.c. r.m.s. or d.c.
$U \leq 2$	$U \leq 2$	$\hat{U} \leq 2,8$	62,5
$2 < U \leq 12,5$	$2 < U \leq 12,5$	$2,8 < \hat{U} \leq 17,6$	$125 / U$
$12,5 < U \leq 18,7$	$12,5 < U \leq 18,7$	$17,6 < \hat{U} \leq 26,4$	10
$18,7 < U \leq 30$	$18,7 < U \leq 60$	$26,4 < \hat{U} \leq 42,4$	$200 / U$

<sup>a</sup> The peak value ( $\hat{U}$ ) applies to non-sinusoidal a.c. and to d.c. with ripple exceeding 10 %, and is provided for convenience. The r.m.s. value of the maximum available current shall be determined as that value is related to heating.

<sup>b</sup> The evaluation is based on the specified time-current breaking characteristic of the device, which is different from the RATED breaking current. (For example, an ANSI/UL 248-14 5 A fuse is specified to break 10 A at 120 s or less and an IEC 60127 T-type 4 A fuse is specified to break at 8,4 A at 120 s or less.)

<sup>c</sup> The breaking current of fuses is dependent on temperature, and this has to be taken into account if the temperature immediately around the fuse is significantly higher than the room temperature.

## 9.5 Requirements for equipment containing or using flammable liquids

Flammable liquids contained in, or specified for use with, the equipment shall not cause the spread of fire in NORMAL CONDITION or in SINGLE FAULT CONDITION.

The HAZARDS arising from flammable liquids are considered to be reduced to a tolerable level if one of the following requirements is met.

- The temperature of the surface of the liquid and parts in contact with the surface, in NORMAL CONDITION and SINGLE FAULT CONDITION, is limited to a temperature not exceeding  $t - 25$  °C, where  $t$  is the fire point of the liquid (see 10.3 b)).

NOTE Fire point is the temperature to which a liquid must be heated (under specified conditions) so that at which the vapour/air mixture at the surface will support a flame for at least 5 s when an external flame is applied and withdrawn.

- The quantity of liquid is limited to an amount that could not cause the spread of fire.
- If the liquid can be ignited, the flames are contained to prevent the spread of fire outside the equipment. Detailed instructions for use shall be provided to establish adequate RISK reduction procedures.

Conformity with a) and b) is checked by inspection and by temperature measurement as specified in 10.4.

Conformity with c) is checked as specified in 4.4.4.3.

NOTE 2—For liquids with toxic combustion by-products, it may be convenient to use a different liquid with similar burn characteristics for testing purposes.

## 9.6 Overcurrent protection

### 9.6.1 General

Equipment intended to be energized from a MAINS supply shall be protected by fuses, circuit-breakers, thermal cut-outs, impedance limiting circuits or similar means, to provide protection against excessive current being drawn from the MAINS in case of a fault in the equipment.

NOTE 1—Overcurrent protection devices supplied with the equipment are intended to provide protection against faults which result in increased current flow, and therefore, increased

heating and the probability of the start and spread of fire. These devices are not intended to provide protection against short-circuits between MAINS conductors and protective earth conductors. The building installation contains overcurrent protection devices in each unearthed MAINS conductor which are intended to protect against short-circuits between the MAINS conductor and protective earth. The breaking capacity of the overcurrent protection device should be compatible with the current RATING of the installation.

A minimum of BASIC INSULATION is required between MAINS-connected parts of opposite polarity on the supply side of the overcurrent protection device.

Overcurrent protection devices shall not be fitted in the protective conductor. Fuses or single pole circuit-breakers shall not be fitted in the neutral conductor of multi-phase equipment.

**NOTE 2**—Overcurrent protection devices (for example, fuses) should preferably be fitted in all supply conductors. If fuses are used as overcurrent protection devices, the fuse holders should be mounted adjacent to each other. The fuses should be of the same RATING and characteristic. Overcurrent protection devices should preferably be located on the supply side of the MAINS CIRCUITS in the equipment, including any MAINS switch. It is recognized that, in equipment generating high frequencies, it is essential for the interference suppression components to be located between the MAINS supply and the overcurrent protection devices.

*Conformity is checked by inspection and by measurement, and for solid insulation by the a.c. voltage test of 6.8.3.1 with a duration of at least 1 min (without humidity preconditioning) with the test voltage from Table 5 for BASIC INSULATION for the appropriate line-to-neutral voltage. EMC capacitors meeting the requirements of 14.1 may be disconnected during the voltage test.*

#### **9.6.2 PERMANENTLY CONNECTED EQUIPMENT**

Overcurrent protection devices are optional in PERMANENTLY CONNECTED EQUIPMENT. If none are fitted, the installation instructions shall specify the characteristics of the overcurrent protection devices required in the building installation.

*Conformity is checked by inspection.*

#### **9.6.3 Other equipment**

If an overcurrent protection device is provided, it shall be within the equipment.

*Conformity is checked by inspection.*

### **10 Equipment temperature limits and resistance to heat**

#### **10.1 Surface temperature limits for protection against burns**

~~The temperature of easily touched surfaces shall not exceed the values of Table 19 in NORMAL CONDITION, and 105 °C in SINGLE FAULT CONDITION, at an ambient temperature of 40 °C.~~

~~Easily touched surfaces of equipment RATED for a maximum ambient temperature above 40 °C are permitted to exceed the values of Table 19 in NORMAL CONDITION, and to exceed 105 °C in SINGLE FAULT CONDITION, by not more than the amount by which the maximum RATED temperature exceeds 40 °C.~~

For all equipment, the temperature of easily touched surfaces shall not exceed the values of Table 19 in NORMAL CONDITION, and 105 °C in SINGLE FAULT CONDITION (70 °C for equipment intended to be used by STUDENT OPERATORS below the age of 14 years), when operated at an ambient temperature of 40 °C.

For equipment RATED for operation at an ambient temperature above 40 °C, easily touched surfaces are permitted to exceed the values in Table 19 in NORMAL CONDITION, and to exceed 105 °C in SINGLE FAULT CONDITION (70 °C for equipment intended to be used by STUDENT OPERATORS below the age of 14 years), by not more than the amount by which the maximum RATED ambient temperature exceeds 40 °C, when the equipment is operated at that maximum RATED ambient temperature.

If easily touched heated surfaces are necessary for the processing or heating of materials, or where otherwise not avoidable, they are permitted to exceed the values of Table 19 in NORMAL CONDITION and to exceed 105 °C (70 °C for equipment intended to be used by STUDENT OPERATORS below the age of 14 years) in SINGLE FAULT CONDITION, provided that they are recognizable as such by appearance or function or are marked with symbol 13 of Table 1. Equipment heated by its environment to temperature values exceeding the values in Table 19 in NORMAL CONDITION and 105 °C in SINGLE FAULT CONDITION need not to be marked with symbol 13.

Surfaces protected by barriers that prevent them from being touched accidentally are not considered to be easily touched surfaces, provided that the barriers cannot be removed without the use of a TOOL. Each fastener holding the barrier in place shall require more than one turn to release.

**Table 19 – Surface temperature limits in NORMAL CONDITION**

Part	<u>Limit for &lt; 14 years °C</u>	<u>Limit for ≥ 14 years °C</u>
1 Outer surface of ENCLOSURE (unintentional contact)		
a) metal, uncoated or anodized	<u>60</u>	65
b) metal, coated (paint, non-metallic)	<u>60</u>	80
c) plastics	<u>70</u>	85
d) glass and ceramics	<u>70</u>	80
e) small areas (<2 cm <sup>2</sup> ) that are not likely to be touched in NORMAL USE	<u>65</u>	100
f) <u>plastic film or label on uncoated metal<sup>a</sup></u>	<u>70</u>	<u>85</u>
2 Knobs and handles (NORMAL USE contact)		
a) metal	<u>50</u>	55
b) plastics	<u>60</u>	70
c) glass and ceramics	<u>55</u>	65
d) non-metallic parts that in NORMAL USE are held only for short periods (1 s to 4 s)	<u>70</u>	70
NOTE – EN 563 gives information about the effect of the duration of contact.		
<sup>a</sup> <u>Plastic film (polyamide 0,4 mm thick). Other plastic materials and thicknesses may be evaluated according to their heat conductivity properties (see burn threshold in IEC Guide 117).</u>		

*Conformity is checked by measurement as specified in 10.4, and by inspection of barriers to check that they protect against accidentally touching surfaces that are at temperatures above the values of Table 19, and that they cannot be removed without a TOOL.*

## 10.2 Temperatures of windings

If a HAZARD could be caused by excessive temperature, the temperature of the insulating material of windings shall not exceed the values of Table 20 in NORMAL CONDITION and SINGLE FAULT CONDITION.

*Conformity is checked by measurement as specified in 10.4, in NORMAL CONDITION and in the applicable SINGLE FAULT CONDITIONS of 4.4.2.5, 4.4.2.10 and 4.4.2.11, and also in any other SINGLE FAULT CONDITIONS that could cause a HAZARD as a result of excessive temperature.*



**Table 20 – Maximum temperatures for insulation material of windings**

<b>Class of insulation</b> (see IEC 60085)	<b>NORMAL CONDITION</b> °C	<b>SINGLE FAULT CONDITION</b> °C
Class A	105	150
Class B	130	175
Class E	120	165
Class F	155	190
Class H	180	210

### 10.3 Other temperature measurements

The following other measurements are made, if applicable, for the purposes of other sub-clauses. Tests are made in NORMAL CONDITION unless stated.

- a) The temperature of a field-wiring TERMINAL box or compartment is measured if there is a possibility that it could exceed 60 °C at an ambient temperature of 40 °C, or the maximum RATED ambient temperature if higher (in connection with the marking requirement of 5.1.8).
- b) The temperature of the surface of flammable liquids, and parts in contact with the surface, is measured in the SINGLE FAULT CONDITIONS of 4.4.2.10 and 4.4.2.11 (in connection with 9.5 a)).
- c) The temperature of non-metallic ENCLOSURES is measured during the test of 10.5.1 (to establish a base temperature for the test of 10.5.2).
- d) The temperature of parts made of insulating material which are used to support parts connected to the MAINS supply (to establish a temperature for test 1) of 10.5.3).
- e) The temperature of TERMINALS carrying a current exceeding 0,5 A if substantial heat could be dissipated in case of poor contact (to establish a temperature for test 1) of 10.5.3).

### 10.4 Conduct of temperature tests

#### 10.4.1 General

*Equipment shall be tested under reference test conditions. Unless a particular SINGLE FAULT CONDITION specifies otherwise, the manufacturer's instructions concerning ventilation, cooling liquid, limits for intermittent use, etc. are followed. Any cooling liquid shall be at the highest RATED temperature.*

*Maximum temperature is determined by measuring the temperature rise under reference test conditions and adding this rise to 40 °C, or to the maximum RATED ambient temperature if higher.*

*The temperature of insulating material of windings is measured as the temperature of winding wire and of core lamination in contact with the insulating material. It can be determined by the resistance method or by using temperature sensors selected and positioned so that they have a negligible effect on the temperature of the winding. The latter method may be used if the windings are non-uniform or if it is difficult to measure resistance.*

*Temperatures are measured when steady state has been reached.*

#### 10.4.2 Temperature measurement of heating equipment

*Equipment intended to produce heat for functional purposes is tested in a test corner.*

*The test corner consists of two walls at right angles, a floor and, if necessary, a ceiling, all of plywood approximately 20 mm thick and painted matt black. The linear dimensions of the test corner should be at least 15 % greater than those of the equipment under test. Equipment is*

*positioned at the distances from the walls, ceiling, or floor specified by the manufacturer. If no distances are specified then:*

- a) equipment normally used on a floor or a table is placed as near to the walls as possible;*
- b) equipment normally fixed to a wall is mounted on one of the walls, as near to the other wall and to the floor or ceiling as is likely to occur in NORMAL USE;*
- c) equipment normally fixed to a ceiling is fixed to the ceiling as near to the walls as is likely to occur in NORMAL USE.*

#### **10.4.3 Equipment intended for installation in a cabinet or a wall**

*Such equipment is built in as specified in the installation instructions, using walls of plywood painted matt black, approximately 10 mm thick when representing the walls of a cabinet, approximately 20 mm thick when representing the walls of a building.*

### **10.5 Resistance to heat**

#### **10.5.1 Integrity of CLEARANCES and CREEPAGE DISTANCES**

CLEARANCES and CREEPAGE DISTANCES shall meet the requirements of 6.7 when the equipment is operated at an ambient temperature of 40 °C, or the maximum RATED ambient temperature if higher.

*Conformity, in cases of doubt if the equipment produces an appreciable amount of heat, is checked by operating the equipment under the reference test conditions of 4.3, except that the ambient temperature is 40 °C, or the maximum RATED ambient temperature if higher. After this test, CLEARANCES and CREEPAGE DISTANCES shall not have been reduced below the requirements of 6.7.*

*If the ENCLOSURE is non-metallic, the temperature of parts of the ENCLOSURE is measured during the above test for the purposes of 10.5.2.*

#### **10.5.2 Non-metallic ENCLOSURES**

ENCLOSURES of non-metallic material shall be resistant to elevated temperatures.

*Conformity is checked by test, after one of the following treatments.*

- a) A non-operative treatment, in which the equipment, not energized, is stored for 7 h at 70 °C ± 2 °C, or at 10 °C ± 2 °C above the temperature measured during the test of 10.5.1, whichever is higher. If the equipment contains components that might be damaged by this treatment, an empty ENCLOSURE may be treated, followed by assembly of the equipment at the end of the treatment.*
- b) An operative treatment, in which the equipment is operated under the reference test conditions of 4.3, except that the ambient temperature is 20 °C ± 2 °C above 40 °C, or above the maximum RATED ambient temperature if higher than 40 °C.*

Within 10 minutes of the end of treatment the equipment shall be subjected to the suitable stresses of 8.2 and 8.3, and meet the pass criteria of 8.1.

#### **10.5.3 Insulating material**

Insulating material shall have adequate resistance to heat.

- a) Parts that are made of insulating material, and which are used to support other parts that are connected to the MAINS supply, shall be made of insulating materials that will not cause a HAZARD if short circuits occur inside the equipment.*
- b) If in NORMAL USE, TERMINALS carry a current exceeding 0,5 A and if substantial heat could be dissipated in case of poor contact, the insulation which supports the TERMINALS shall be*

made of material that will not soften to an extent that could cause a HAZARD or further short circuits.

*In case of doubt, conformity is checked by examination of material data. If the material data is not conclusive, one of the following tests is performed.*

- 1) *A sample of the insulating material, at least 2,5 mm thick, is subjected to a ball-pressure test using the test apparatus Figure 14. The test is made in a heating cabinet at the temperature measured as specified in 10.3 d) or 10.3 e)  $\pm 2$  °C, or at 125 °C  $\pm 2$  °C, whichever is higher. The part to be tested is supported so that its upper surface is horizontal, and the spherical part of the apparatus is pressed against this surface with a force of 20 N. After 1 h the apparatus is removed and the sample is cooled within 10 s to approximately room temperature by immersion in cold water. The diameter of the impression caused by the ball shall not exceed 2 mm.*

*NOTE 1—If necessary, the required thickness can be obtained by using two or more sections of the part.*

*NOTE 2—For bobbins, only those parts that support or retain TERMINALS in position are subjected to the test.*

*NOTE See IEC 60695-10-2 for more information about this test.*

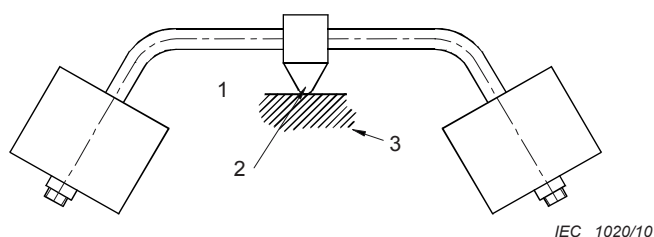

#### Key

- 1 Part to be tested
- 2 Spherical part of the apparatus (diameter 5 mm)
- 3 Support

**Figure 14 – Ball-pressure test apparatus**

- 2) *The Vicat softening test of ISO 306, method A120. The Vicat softening temperature shall be at least 130 °C.*

## 11 Protection against HAZARDS from fluids

### 11.1 General

Equipment shall be designed to give protection to OPERATORS and the surrounding area against HAZARDS from fluids encountered in NORMAL USE.

NOTE 1 Fluids likely to be encountered fall into three categories:

- a) those having continuous contact, for example, in vessels intended to contain them;
- b) those having occasional contact, for example, cleaning fluids;
- c) those having accidental (unexpected) contact. The manufacturer cannot safeguard against such cases.

Fluids specified by the manufacturer, including cleaning and decontaminating fluids, are considered. Other fluids are not considered.

NOTE 2 The term “fluids” includes both liquids and gases.

*Conformity is checked by the treatment and tests of 11.2 to 11.5.*

## 11.2 Cleaning

If a cleaning or decontamination process is specified by the manufacturer, this shall not cause a direct HAZARD, nor an electrical HAZARD, nor a HAZARD resulting from corrosion or other weakening of structural parts relied upon for safety.

*Conformity is checked by cleaning the equipment three times if a cleaning process is specified and decontaminating the equipment once if a decontamination process is specified, in accordance with the manufacturer's instructions. If, immediately after this treatment, there are any signs of wetting of parts likely to cause a HAZARD, the equipment shall pass the voltage tests of 6.8 (without humidity preconditioning) applicable to the type of insulation (see 6.7) and ACCESSIBLE parts shall not exceed the limits of 6.3.1.*

## 11.3 Spillage

If, in NORMAL USE, liquid is likely to be spilt into the equipment, the equipment shall be designed so that no HAZARD will occur, for example as a result of the wetting of insulation or of internal uninsulated parts, or as a result of the contact of potentially aggressive substances (such as corrosive, toxic or flammable liquids) with parts of the equipment.

If in NORMAL USE potentially aggressive substances (such as corrosive, toxic or flammable liquids) are likely to be spilt on parts of the equipment, the wetted material should be analyzed to determine compatibility with the aggressive substance.

*Conformity is checked by inspection. In case of doubt, 0,2 l of ~~water~~ dilute salt solution is poured steadily from a height of 0,1 m over a period of 15 s onto each point in turn where liquid might gain access to electrical parts. The salt solution contains 10 g of sodium chloride in 1 l of distilled water. Immediately after this treatment, the CLEARANCES and solid insulation shall pass the voltage tests of 6.8 (without humidity preconditioning) applicable to the type of insulation (see 6.7) and ACCESSIBLE parts shall not exceed the limits of 6.3.1.*

## 11.4 Overflow

Liquid overflowing from any container in the equipment which can be overfilled shall not cause a HAZARD during NORMAL USE, for example as a result of the wetting of insulation or of internal uninsulated parts that are HAZARDOUS LIVE.

Equipment likely to be moved while a container is full of liquid shall be protected against liquid surging out of the container.

*Conformity is checked by the following treatment and tests. The liquid container is completely filled. A further quantity of liquid equal to 15 % of the capacity of the container or 0,25 l, whichever is the greater, is then poured in steadily over a period of 60 s. If equipment is likely to be moved while a container is full of liquid, it is then tilted 15° in the least favourable direction from the position of NORMAL USE. Immediately after this treatment, the CLEARANCES and solid insulation shall pass the voltage tests of 6.8 (without humidity preconditioning) applicable to the type of insulation (see 6.7) and ACCESSIBLE parts shall not exceed the limits of 6.3.1.*

## 11.5 Battery electrolyte

Batteries shall be so mounted that safety cannot be impaired by leakage of their electrolyte.

NOTE Also see 13.2.2.

*Conformity is checked by inspection.*

## 11.6 Specially protected equipment

If the equipment is RATED and marked by the manufacturer as conforming to one of the stated degrees of protection of IEC 60529, it shall resist the entry of water to the extent specified.

*Conformity is checked by inspection and by subjecting the equipment to the appropriate treatment of IEC 60529, after which the CLEARANCES and solid insulation shall pass the voltage tests of 6.8 (without humidity preconditioning) applicable to the type of insulation (see 6.7) and ACCESSIBLE parts shall not exceed the limits of 6.3.1.*

## 11.7 Fluid pressure and leakage

### 11.7.1 Maximum pressure

The maximum pressure to which a part of the equipment can be subjected in NORMAL USE or SINGLE FAULT CONDITION shall not exceed the RATED maximum working pressure for the part.

The maximum pressure shall be considered to be the highest of the following:

- a) the RATED maximum supply pressure specified for an external source;
- b) the pressure setting of an overpressure safety device provided as part of the assembly;
- c) the maximum pressure that can be developed by a pressure generating device that is part of the assembly, unless the pressure is limited by an overpressure safety device.

*Conformity is checked by inspection of the RATINGS of the parts and, if necessary, by measuring pressures.*

NOTE ~~Equipment meeting the requirements of 11.7 may not be accepted as conforming to national requirements relating to high pressures. In some countries, national requirements relating to high pressures are different from the requirements of 11.7.~~ Annex G describes requirements and tests which are accepted as evidence of conformity with national regulations in the USA, in Canada, and in some other countries.

### 11.7.2 Leakage and rupture at high pressure

Fluid-containing parts which in NORMAL USE have both of the following characteristics shall not cause a HAZARD through rupture or leakage:

- a) a product of pressure and volume greater than 200 kPa·l;
- b) a pressure greater than 50 kPa.

*Conformity is checked by inspection and, if a HAZARD could arise, by the following hydraulic test.*

*The test pressure is the maximum pressure multiplied by a factor of 1,5 for testing against leakage and by factor 2,0 for testing against burst.*

NOTE National authorities might allow safety to be established by calculation, for example according to the, Pressure Equipment Directive (97/23/EC).

*The pressure is raised gradually to the specified test value and is held at that value for 1 min. The sample shall not burst, suffer from permanent (plastic) deformation (factor 2,0), or leak (factor 1,5). Leakage at a gasket during these tests is not considered a failure unless it occurs at a pressure of below 1,5 times the maximum working pressure.*

*No leakage is allowed from fluid-containing parts intended for toxic, flammable, or otherwise hazardous substances if it could be a HAZARD.*

*If unmarked fluid-containing parts and pipes cannot be hydraulically tested, integrity is to be verified by other suitable tests, for example, pneumatic tests using suitable media, at the same test pressure as for the hydraulic test.*

As an exception to the above requirements, fluid-containing parts of refrigeration systems shall meet the relevant pressure-related requirements of IEC 60335-2-24 or IEC 60335-2-89 as applicable.

*Conformity is checked as specified in IEC 60335-2-24 or IEC 60335-2-89 as applicable.*

### **11.7.3 Leakage from low-pressure parts**

Leakage from fluid-containing parts at pressures lower than the levels of 11.7.2 shall not cause a HAZARD.

*Conformity is checked by inspection of the RATINGS of parts and, if necessary, by subjecting the parts to a fluid pressure of twice the maximum pressure in NORMAL USE. No leakage shall occur which could cause a HAZARD.*

### **11.7.4 Overpressure safety device**

An overpressure safety device shall not operate in NORMAL USE. It shall conform to the following requirements.

- a) It shall be connected as close as possible to the fluid-containing parts of the system that it is intended to protect.
- b) It shall be installed so as to provide easy access for inspection, maintenance and repair.
- c) It shall not be capable of being adjusted without the use of a TOOL.
- d) It shall have its discharge opening so located and directed that the released material is not directed towards any person.
- e) It shall have its discharge opening so located and directed that operation of the device will not deposit material on parts if that could cause a HAZARD.
- f) It shall have adequate discharge capacity to ensure that the pressure cannot exceed the RATED maximum working pressure of the system.

There shall be no shut-off valve between an overpressure safety device and the parts that it is intended to protect.

*Conformity is checked by inspection and test.*

## **12 Protection against radiation, including laser sources, and against sonic and ultrasonic pressure**

### **12.1 General**

The equipment shall provide protection against the effects of internally generated ultraviolet, ionizing and microwave radiation; laser sources, and sonic and ultrasonic pressure.

*Conformity tests are carried out if the equipment is likely to cause such HAZARDS.*

### **12.2 Equipment producing ionizing radiation**

#### **12.2.1 Ionizing radiation**

##### **12.2.1.1 General**

Equipment containing or generating ionizing radiation (from either radioactive sources or X-radiation) shall meet the following requirements.

- a) If it is intended to emit radiation, it shall meet the requirements of 12.2.1.2. Alternatively, if it is within the scope of IEC 62598 ~~60405~~, it shall be tested, classified, and marked according to IEC 62598 ~~60405~~.



- b) If it uses or generates radiation but only emits stray radiation, it shall meet the requirements of 12.2.1.3.

NOTE 1 See IEC 62598 ~~60405~~ for further information on the requirements for equipment which utilizes ionizing radiation.

NOTE 2 ~~For X-ray and gamma radiation: 1  $\mu\text{Sv/h}$  = 0,1 mR/h and 5  $\mu\text{Sv/h}$  = 0,5 mR/h.~~

NOTE 2 Equipment that emits ionizing radiation is regulated by health authorities in most countries. These regulations often address both the emissions of radiation from the equipment and the cumulative dose of radiation received by the workers and others in the vicinity of the equipment. See the Ionizing Radiation Directive (96/29/EURATOM) or USA 29 CFR 1910.1096 as examples of these regulations.

*Conformity is checked by inspection of the IEC 62598 ~~60405~~ compliance documentation or as specified in 12.2.1.2 or 12.2.1.3, as applicable.*

### 12.2.1.2 Equipment intended to emit radiation

Equipment which contains radioactive substances or that generates x-rays, and is intended to emit ionizing radiation outside the equipment, shall be tested and marked as follows.

~~The effective dose rate of radiation shall be measured at a constant distance of 50 mm to 1 m from all surfaces of the equipment. The measuring distance shall be between 50 mm and 1 m. If measurements are performed at any distance other than 50 mm, the equivalent effective dose rate at a distance of 50 mm shall be calculated. If the effective dose rate at any easily reached point 50 mm from the outer surface exceeds 5  $\mu\text{Sv/h}$ , the equipment shall be marked with all the following markings, if applicable:~~

For x-ray sources, the effective dose rate of radiation shall be measured at a distance of 50 mm from the surface of the equipment, or for radioactive sources, 100 mm from the surface of the equipment. At these distances, the effective dose rate shall not exceed 5  $\mu\text{Sv/h}$  for X-ray radiation, 50  $\mu\text{Sv/h}$  for beta particle radiation, or 10  $\mu\text{Sv/h}$  for gamma radiation. The equipment shall be marked with all of the following markings, if applicable:

- a) symbol 17 of Table 1;
- b) for equipment containing one or more radioactive substances, the abbreviations of the radionuclides;
- c) ~~either with the maximum dose rate value at 1 m, or with a dose rate value between 1  $\mu\text{Sv/h}$  and 5  $\mu\text{Sv/h}$  at the appropriate distance in m~~ either the maximum dose rate value at 50 mm (X-rays), or at 100 mm (other ionizing radiation types).

NOTE Examples of suitable markings are: "2,5  $\mu\text{Sv/h}$  at 4-m 50 mm"; "3  $\mu\text{Sv/h}$  at 0,3-m 0,1 m".

*Conformity is checked by measuring the amount of radiation in the conditions that will produce maximum radiation. The method of determining the amount of radiation shall be effective over the range of possible radiation energies. Equipment containing X-ray sources is set to produce the maximum possible level of radiation.*

### 12.2.1.3 Equipment not intended to emit radiation

The effective dose rate of unintended stray radiation at any easily reached point 100 mm from the outer surface of the equipment shall not exceed 1  $\mu\text{Sv/h}$ .

NOTE Such equipment includes radioactive substances, cathode-ray tubes, X-ray sources, or electron accelerators with voltages exceeding 5 kV.

*Conformity is checked by measuring the amount of radiation in the conditions that will produce maximum radiation. The method of determining the amount of radiation shall be effective over the range of possible radiation energies. Equipment containing cathode-ray tubes is tested while displaying a pattern from each beam not exceeding 30 mm  $\times$  30 mm or the smallest possible display, whichever is larger. Equipment containing X-ray sources is set*

to produce the maximum possible level of radiation. Displays are positioned so as to produce maximum radiation.

### 12.2.2 Accelerated electrons

The equipment shall be so constructed that compartments in which electrons are accelerated by voltages exceeding 5 kV cannot be opened without the use of a TOOL.

Conformity is checked by inspection.

### 12.3 Ultraviolet (UV) Optical radiation

Lamp and lamp systems emitting ultraviolet, visible, or infrared radiation, including light emitting diodes, shall be assessed in accordance with IEC 62471 except for sources considered to be safe (Table 21), or conditionally safe (Table 22). Lamp and lamp systems assessed to be in Risk Groups 1, 2 or 3 of IEC 62471 shall be marked in accordance with IEC/TR 62471-2. Protective measures, restrictions on use and operating instructions that may be necessary for a STUDENT OPERATOR shall be provided, including the applicable conditions of use of Table 22.

~~Equipment containing a UV source not designed to provide external UV illumination shall not permit unintentional escape of UV radiation that could cause a HAZARD.~~

NOTE 1 Effects of UV-radiation include biological damage and degradation of materials such as plastic ENCLOSURES and insulation.

NOTE 2 Attention is drawn to the possible existence of additional guidelines or requirements ~~which may be specified by national authorities responsible for the~~ protection of the health and safety of labour forces.

Conformity is checked by inspection and by evaluation of the RISK assessment documentation.

**Table 21 – Lamp or lamp systems considered photobiologically safe**

<u>Lamp or lamp system</u>
<u>Indicator LED's</u>
<u>Personal digital assistant screens</u>
<u>LCD screens</u>
<u>Computer displays</u>
<u>Photographic flash lamps</u>
<u>Interactive whiteboard presentation equipment</u>
<u>Task lighting with tungsten filament lamps, compact fluorescent tubes, or fluorescent tubes with diffusers</u>

**Table 22 – Lamp or lamp systems considered photobiologically conditionally safe**

<u>Lamp or lamp system</u>	<u>Conditions of use</u>
<u>Fluorescent tubes without diffusers</u>	<u>Safe at normal illumination levels</u>
<u>Metal halide, or high-pressure mercury flood lights</u>	<u>Safe if the front cover glass is intact and if the lamp is not in line of sight</u>
<u>Desktop projectors</u>	<u>Safe provided the beam is not looked into</u>
<u>Low-pressure UVA blacklights</u>	<u>Safe if not in line of sight and hands are not irradiated while holding the blacklight</u>



## 12.4 Microwave radiation

In NORMAL CONDITION and in SINGLE FAULT CONDITION, at any point 50 mm from the equipment, the power density of spurious microwave radiation at frequencies between 1 GHz and 100 GHz shall not exceed  $10 \text{ W/m}^2$ . ~~This requirement does not apply to parts of the equipment where microwave radiation is propagated intentionally, for example, at waveguide output ports. The power density at any point 50 mm from a waveguide output port shall not exceed  $10 \text{ W/m}^2$ .~~

*Conformity is checked by test under reference test conditions.*

## 12.5 Sonic and ultrasonic pressure

### 12.5.1 Sound level

If equipment produces noise at a level which could cause a HAZARD, the manufacturer shall measure the maximum sound pressure level which the equipment can produce (except for sound from alarms and sound from parts remote from the equipment) and shall calculate the maximum sound power level as specified in ISO 3746 or ISO 9614-1.

Installation instructions shall specify how the RESPONSIBLE BODY can ensure that the sound pressure level from equipment, at its point of use after installation, will not reach a value which could cause a HAZARD. These instructions shall identify readily available and practicable protective materials or measures which may be used, including the fitting of noise-reducing baffles or hoods.

NOTE A sound pressure level of 80 dBA above a reference sound pressure of  $20 \mu\text{Pa}$  is at present regarded by many authorities as the threshold at which a HAZARD can be caused. Special means, such as the use of protective earpieces, can make a higher level non-hazardous to an OPERATOR.

NOTE 2—The instructions for use should recommend that the sound pressure level be measured or calculated by the RESPONSIBLE BODY both at the OPERATOR'S position in NORMAL USE and at whatever point 1 m from the ENCLOSURE of the equipment has the highest sound pressure level.

*Conformity is checked by measuring the maximum A-weighted sound pressure level at the OPERATOR'S position and at bystander positions, and if necessary, calculating the maximum A-weighted sound power level produced by the equipment, as specified in either ISO 3746 or ISO 9614-1. The following conditions apply.*

- a) *During measurement, any part necessary for the correct operation of the equipment and supplied by the manufacturer as an integral part of such equipment, for example, a pump is fitted and operated as in NORMAL USE.*
- b) *Sound level meters used in the measurement conform either to type 1 of IEC 61672-1 or, if an integrating sound level meter, to type 1 of IEC 61672-2.*
- c) *The test room is semi-reverberant, with a hard reflecting floor. The distance between any wall or any other object and the surface of the equipment is not less than 3 m.*
- d) *The equipment is tested with the combination of load and other operating conditions (for example, pressure, flow, temperature) which creates the maximum sound pressure level.*

### 12.5.2 Ultrasonic pressure

If equipment not intended to emit ultrasound produces ultrasound at a level which could cause a HAZARD, the manufacturer shall measure the maximum ultrasonic pressure level which the equipment can produce. When measured both at the OPERATOR'S normal position and at 1 m from the position on the equipment with the highest pressure level, the ultrasonic pressure shall not exceed 110 dB above the reference pressure value of  $20 \mu\text{Pa}$ , for frequencies between 20 kHz and 100 kHz.

*Conformity is checked by measuring the pressure under reference test conditions.*

If equipment intended to emit ultrasound produces ultrasonic pressure at a level which could cause a HAZARD, the manufacturer shall measure the maximum ultrasonic pressure level which the equipment can produce.

The sound pressure shall be measured at the OPERATOR'S normal position and at 1 m from the position on the equipment with the highest pressure level both outside and inside the useful beam.

Outside the useful beam the ultrasonic pressure shall not exceed 110 dB above the reference pressure value of 20  $\mu$ Pa, for frequencies between 20 kHz and 100 kHz.

If inside the useful beam the ultrasonic pressure exceeds 110 dB for frequencies between 20 kHz and 100 kHz, the equipment shall be marked with symbol 14 of Table 1 and the following information shall be in the documentation:

- a) the dimensions of the useful beam;
- b) the area of the useful beam in which the ultrasonic pressure exceeds 110 dB;
- c) the maximum sound pressure value inside the beam area.

*Conformity is checked by inspection and measurement of the pressure under reference test conditions.*

## 12.6 Laser sources

Equipment employing laser sources shall meet the requirements of IEC 60825-1.

Laser sources intended for use by STUDENT OPERATORS below the age of 11 years shall meet applicable requirements of IEC 60825-1 for a Class 1 laser product. Laser sources intended for use by STUDENT OPERATORS at least 11 years old shall meet applicable requirements of IEC 60825-1 for a Class 1 or Class 2 laser product.

Laser sources that are RATED for Class 2 of IEC 60825-1 or higher and are intended for use in laboratories shall be capable of being clamped to prevent them from being moved. The instructions for the laser source shall state that the laser source must be made stationary before use by fixing it in position with a clamp.

Laser diode modules and laser pointers shall have automatic power control limiting the light output to 1 mW.

*Conformity is checked by inspection and as specified in IEC 60825-1.*

## 13 Protection against liberated gases and substances, explosion and implosion

### 13.1 Poisonous and injurious gases and substances

Equipment shall not liberate dangerous amounts of poisonous or injurious gases or substances in NORMAL CONDITION.

The manufacturer's documentation shall state which potentially poisonous or injurious gases or substances can be liberated, and the quantities.

*Conformity is checked by inspection of the manufacturer's documentation. The wide variety of gases and substances makes it impossible to specify conformity tests based on limit values, so reference should be made to tables of occupational threshold limit values.*

## 13.2 Explosion and implosion

### 13.2.1 Components

If components liable to explode if overheated or overcharged are not provided with a pressure release device, protection for OPERATORS shall be incorporated in the equipment (see 7.7 concerning expelled parts).

Pressure release devices shall be located so that a discharge will not cause danger to OPERATORS. The construction shall be such that no pressure release device is obstructed.

*Conformity is checked by inspection.*

### 13.2.2 Batteries and battery charging

Batteries shall not cause explosion or produce a fire HAZARD as a result of excessive charge or discharge, or if a battery is installed with incorrect polarity. If necessary, protection shall be incorporated in the equipment, unless the manufacturer's instructions specify that it is for use only with batteries which have built-in protection.

If an explosion or fire HAZARD could occur through fitting a battery of the wrong type (for example, if a battery with built-in protection is specified) there shall be a warning marking on or near the battery compartment or mounting, and a warning in the manufacturer's instructions. An acceptable marking is symbol 14 of Table 1.

If equipment has means for charging rechargeable batteries, and if non-rechargeable cells could be fitted and connected in the battery compartment, there shall be a warning marking in or near the compartment. The marking shall warn against the charging of non-rechargeable batteries and indicate the type of rechargeable battery that can be used with the recharging circuit. An acceptable marking is symbol 14 of Table 1.

The battery compartment shall be designed so that there is no possibility of explosion or fire caused by build-up of flammable gases.

NOTE Also see 11.5.

Battery replacement shall be prevented for equipment designed for use by STUDENT OPERATORS under 14 years of age. Access to the battery shall be protected by a device requiring the use of a TOOL.

*Conformity is checked by inspection, including inspection of battery data, to establish that failure of a single component cannot lead to an explosion or fire HAZARD. If necessary, a short circuit and an open circuit is made on any single component (except the battery itself) whose failure could lead to such a HAZARD.*

*For batteries intended to be replaced by an OPERATOR, an attempt is made to install a battery with its polarity reversed. No HAZARD shall arise.*

### 13.2.3 Implosion of cathode ray tubes

Cathode-ray tubes with a maximum face dimension exceeding 160 mm shall be intrinsically protected against the effects of implosion and against mechanical impact, unless an ENCLOSURE provides adequate protection.

A non-intrinsically protected tube shall be provided with an effective protective screen which cannot be removed without the use of a TOOL. If a separate screen of glass is used, it shall not be in contact with the surface of the tube.

A cathode-ray tube is considered to be intrinsically protected with respect to the effects of implosion if no additional protection is necessary when it is correctly mounted.

*Conformity for cathode-ray tubes is checked as specified in IEC 60065.*

## 14 Components and subassemblies

### 14.1 General

If safety is involved, components and subassemblies, such as power supplies and built-in information technology equipment, shall be used in accordance with their specified RATINGS unless a specific exception is made. They shall conform to one of the following:

- a) applicable safety requirements of a relevant IEC standard. Conformity with other requirements of the component standard is not required. If necessary for the application, components shall be subjected to the tests of this Technical Specification, except that it is not necessary to carry out identical or equivalent tests already performed to check conformity with the component standard.

**NOTE 1**—For example if components meet the safety requirements of IEC 60950-1 but are RATED for a less severe environment than the applicable environment of 1.4, they also need to meet relevant additional requirements of this standard.

- b) the requirements of this Technical Specification and, where necessary for the application, any additional applicable safety requirements of the relevant IEC component standard, except that there are no additional requirements for motors and transformers which have passed the applicable tests of 4.4.2.5, 4.4.2.7, 14.2 and 14.6;
- c) if there is no relevant IEC standard, the requirements of this Technical Specification;
- d) applicable safety requirements of a non-IEC standard which are at least as high as those of the relevant IEC standard, provided that the component has been approved to the non-IEC standard by a recognized testing authority.

**NOTE 2**—Tests performed by a recognized testing authority which confirm conformity with applicable safety requirements do not need to be repeated, even if the tests were performed using a non-IEC standard.

Figure 15 is a flow chart showing methods of conformity verification.

*Conformity is checked by inspection and, if necessary, by test.*

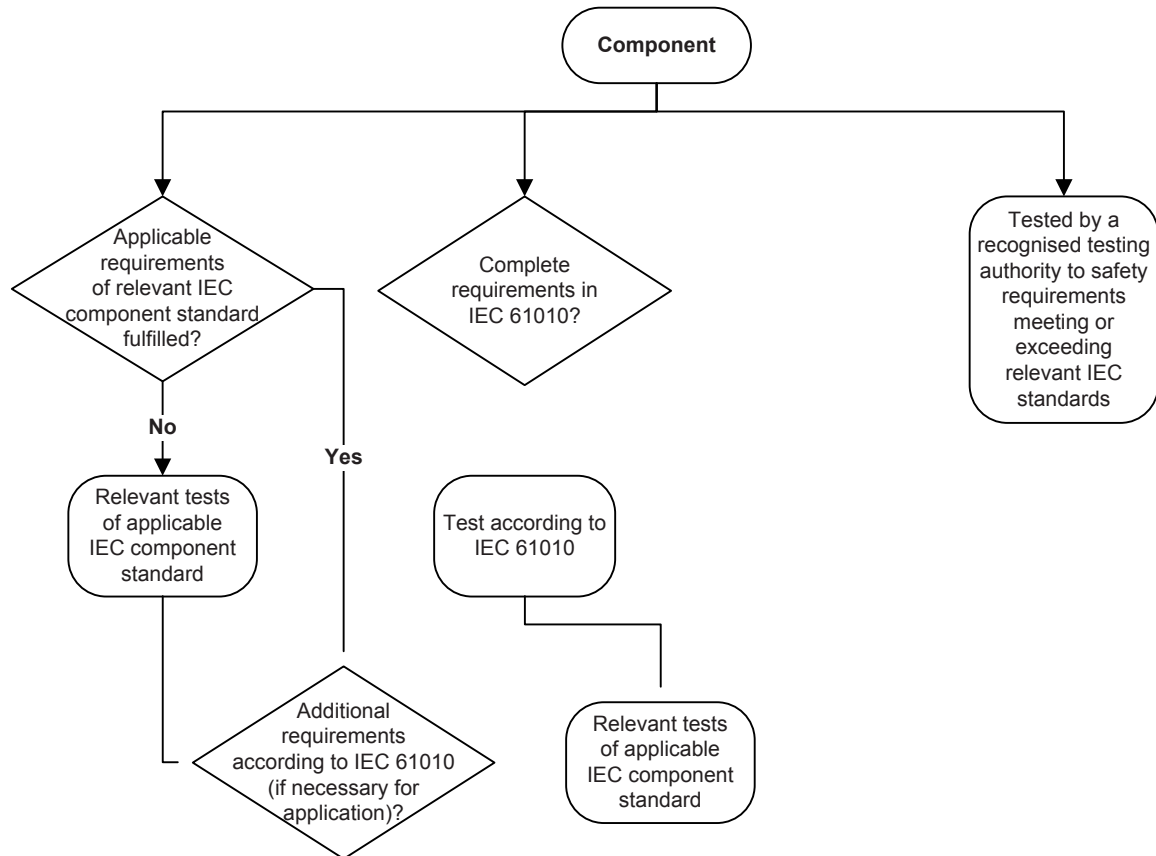

IEC 1021/10

Figure 15 – Flow chart for conformity options 14.1 a), b), c) and d)

## 14.2 Motors

### 14.2.1 Motor temperatures

Motors which, when stopped or prevented from starting (see 4.4.2.5), would present an electric shock HAZARD, a temperature HAZARD, or a fire HAZARD shall be protected by an overtemperature or thermal protection device meeting the requirements of 14.3.

*Conformity is checked by measurement of the temperature in the SINGLE FAULT CONDITION of 4.4.2.5.*

### 14.2.2 Series excitation motors

If an overspeeding series excitation motor could cause a HAZARD, it shall be connected directly to the devices driven by it.

*Conformity is checked by inspection.*

### 14.3 Overtemperature protection devices

Overtemperature protection devices are devices operating in SINGLE FAULT CONDITION. They shall meet all of the following requirements:

- a) be constructed so that reliable function is ensured;
- b) be RATED to interrupt the maximum voltage and current of the circuit in which they are employed;
- c) not operate in NORMAL USE.

If a self-resetting overtemperature protection device is used to prevent a HAZARD in case of failure of a temperature control system (for example a thermostat), the protected part of the equipment shall require intervention before becoming operational again.

*Conformity is checked by inspection of the circuit diagram, the data sheet for the overtemperature protection device, and the method in which it is installed in the equipment, and by the following tests, with the equipment operated in SINGLE FAULT CONDITION (see 4.4). The number of operations is as follows:*

- 1) *self-resetting overtemperature protection devices are caused to operate 200 times;*
- 2) *non-self-resetting overtemperature protection devices, except thermal fuses, are reset after each operation and thus caused to operate 10 times;*
- 3) *non-resetting overtemperature protection devices are caused to operate once.*

*NOTE Forced cooling and resting periods can be introduced to prevent damage to the equipment.*

*During the test, resetting overtemperature protection devices shall operate each time the SINGLE FAULT CONDITION is applied and non-resetting overtemperature protection devices shall operate once. After the test, resetting overtemperature protection devices shall show no sign of damage which could prevent their operation in a further SINGLE FAULT CONDITION.*

### 14.4 Fuse holders

If a fuse is intended to be replaced by an OPERATOR the fuse holder shall not permit HAZARDOUS LIVE parts to be ACCESSIBLE during fuse replacement.

Fuse replacement by a STUDENT OPERATOR shall be prevented. The fuse-holder shall not be openable without the use of a TOOL.

*Conformity is checked by inspection and by testing with the jointed test finger (see Figure B.23) applied without force.*

### 14.5 MAINS voltage selection devices

Devices shall be constructed so that a change from one voltage or one type of supply to another cannot occur accidentally. See 5.1.3 d) for marking requirements.

*Conformity is checked by inspection and manual test.*

### 14.6 MAINS transformers tested outside equipment

If environmental conditions could affect the test results, MAINS transformers tested outside the equipment (see 4.4.2.7) shall be tested in the same conditions as exist inside the equipment.

*Conformity is checked by the short-circuit and overload tests specified in 4.4.2.7, followed by the test of 4.4.4.1 b) and c). If there is any doubt whether a transformer would pass the other tests specified in 4.4.4 and 10.2 when installed in the equipment, the tests are repeated with the transformer installed in the equipment.*

#### 14.7 Printed wiring boards

Printed wiring boards shall be made of material with a flammability classification of V-1 or better of IEC 60695-11-10.

This requirement does not apply to printed wiring boards which contain only limited-energy circuits meeting the requirements of 9.4.

*Conformity of the flammability RATING is checked by inspection of data on the materials. Alternatively, conformity is checked by performing the vertical burn tests of IEC 60695-11-10 on three samples of the relevant parts. The samples may be complete boards, sections of the boards or specimens as specified in IEC 60695-11-10.*

#### 14.8 Circuits or components used as TRANSIENT OVERVOLTAGE limiting devices

TRANSIENT OVERVOLTAGES in a circuit may be limited by circuits or components. Components suitable for this purpose include varistors, spark gaps on printed wiring boards, and ceramic capacitors, in some cases combined with impedances or gas-filled surge arresters.

Any overvoltage limiting component or circuit that forms part of the equipment shall have adequate strength to limit likely TRANSIENT OVERVOLTAGES.

**Table 23 ~~Table 24~~ – Impulse withstand voltages for OVERVOLTAGE CATEGORY II**

Line-to-neutral MAINS voltage V r.m.s. or d.c.	Impulse withstand voltage V
≤ 50	500
> 50 ≤ 100	800
> 100 ≤ 150	1 500
> 150 ≤ 300	2 500
> 300 ≤ 600	4 000
> 600 ≤ 1 000	6 000

*Conformity is checked by applying 5 positive and 5 negative impulses with the applicable impulse withstand voltage of ~~Table 24~~ Table 23, spaced up to 1 min apart, from a hybrid impulse generator (see IEC 61180-1). The generator shall produce an open-circuit voltage waveform of 1,2/50 μs, a short-circuit current waveform of 8/20 μs, with an output impedance (peak open-circuit voltage divided by peak short-circuit current) of 12 Ω (resistance may be added in series if needed to raise the impedance). The test impulse shall be applied while the circuit is working under conditions during NORMAL USE, in combination with the MAINS supply. The MAINS voltage is the maximum RATED line-to-neutral MAINS voltage.*

*The test voltage is applied between each pair of MAINS supply TERMINALS of the equipment where voltage limiting devices are present.*

*No HAZARD shall arise in the event that the component ruptures or overheats during the test. If a rupture occurs, no part of the component shall bridge safety-relevant insulation. If the component overheats, it shall not heat other materials to their self-ignition points. Tripping the circuit breaker of the MAINS supply is an indication of failure.*

*NOTE The test voltage and generator output impedance specified above apply to equipment with a RATING for OVERVOLTAGE CATEGORY II. Conformity for equipment with a RATING for OVERVOLTAGE CATEGORIES III and IV is specified in Clause K.4.*



## 14.9 Small components

Small components (see ISO/IEC Guide 50) that fit entirely into the cylinder in Figure 16 without being compressed shall not be detachable from equipment by a STUDENT OPERATOR aged under 14 years without the use of a TOOL.

NOTE Additional information about small parts is found in ISO 8124-1, EN 71-1 and ASTM F 963-96a.

Conformity is checked by inspection.

Dimensions in mm

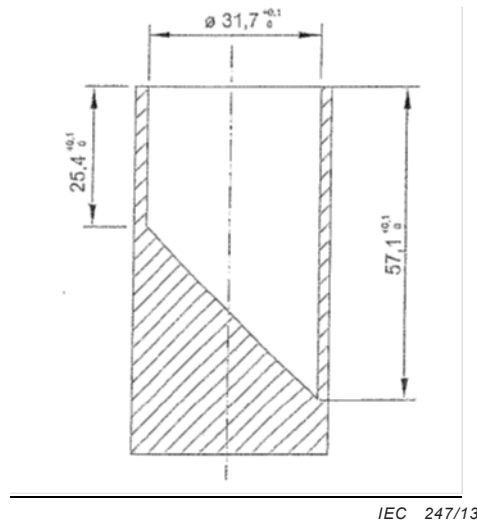

**Figure 16 – Cylinder for checking the size of small components**

## 15 Protection by interlocks

### 15.1 General

Interlocks used to protect OPERATORS from HAZARDS shall prevent an OPERATOR from being exposed to the HAZARD before the HAZARD is removed and shall meet the requirements of 15.2 and 15.3.

*Conformity is checked by inspection and by performing all relevant tests of this Technical Specification.*

### 15.2 Prevention of reactivating

Until the action which caused the interlock to operate has been reversed or cancelled, an interlock for the protection of an OPERATOR shall prevent the HAZARD being re-established by reactivating without the use of a TOOL.

*Conformity is checked by inspection and, if necessary, by attempting to operate by hand any interlock part which can be touched by the jointed test finger for CHILDREN (see Figure B-2 B.3).*

### 15.3 Reliability

An interlock system for the protection of OPERATORS shall ensure that a single fault in the interlock system is either unlikely to occur during the expected life of the equipment, or cannot cause a HAZARD.



*Conformity is checked by assessment of the interlock system. In case of doubt, the interlock system or relevant parts of the system are cycled to switch the least favourable load in NORMAL USE. The number of cycles is twice the maximum number likely to occur during the expected life of the equipment or 10 000 cycles of operation whichever is higher. After the test the protection shall not be impaired.*

## **16 HAZARDS resulting from application**

### **16.1 REASONABLY FORESEEABLE MISUSE**

No HAZARDS shall arise if adjustments, knobs, or other software-based or hardware-based controls are set in a way not intended, and not described in the instructions. Other possible cases of REASONABLY FORESEEABLE MISUSE including by a CHILD that are not addressed by specific requirements in this Technical Specification shall be addressed by RISK assessment (see Clause 17).

*Conformity is checked by inspection and by evaluation of the RISK assessment documentation.*

### **16.2 Ergonomic aspects**

If the following factors could give rise to a HAZARD, a RISK assessment shall be documented, taking into account at least the following aspects:

- a) limitation of body dimensions;
- b) displays and indicators;
- c) accessibility and conventions of controls;
- d) arrangements of TERMINALS.

*Conformity is checked by inspection and by evaluation of the RISK assessment documentation.*

NOTE Risk assessment procedures for ergonomics are found in EN 894-2, EN 894-3, ISO 9241, SEMI S8, and other documents. Not all of the requirements in these documents will be applicable to equipment within the scope of this Technical Specification.

## **17 Risk assessment**

If examination of the equipment shows that HAZARDS not fully addressed in Clauses 6 to 16 (see 1.2.1) might arise, then RISK assessment is required. It shall be carried out and documented to achieve at least a TOLERABLE RISK by an iterative process covering the following.

### a) RISK analysis

RISK analysis is the process to identify HAZARDS and to estimate the RISKS based on the use of available information.

### b) RISK evaluation

Each RISK analysis requires a plan to evaluate the estimated severity and likelihood of a RISK, and to judge the acceptability of the resulting RISK level.

### c) RISK reduction

If the initial RISK level is not acceptable, steps shall be taken to reduce the RISK. The process of RISK analysis and RISK evaluation shall then be repeated, including checking that no new RISKS have been introduced.

RISKS remaining after a RISK assessment shall be identified in the instructions for the RESPONSIBLE BODY. Adequate information about how to mitigate these RISKS shall be given (see 5.4.1 e)).

In selecting the most appropriate methods of RISK reduction, the manufacturer shall apply the following principles, in the order given:

- 1) eliminate or reduce RISKS as far as possible (an inherently safe design and construction);
- 2) take the necessary protective measures in relation to RISKS that cannot be eliminated;
- 3) inform ~~users~~ the RESPONSIBLE BODY of the residual RISKS due to any shortcomings of the protective measures adopted, indicate whether any particular training is required, and specify any need to provide personal protective equipment.

NOTE 1 One RISK assessment procedure is outlined in Annex J. Other RISK assessment procedures are contained in ISO 14971, SEMI S10-1296, IEC 61508, ISO 14121-1, and ANSI B11.TR3. Other established procedures which implement similar steps can also be used.

NOTE 2 Guidance on RISKS to children is given in ISO/IEC Guide 50.

*Conformity is checked by evaluation of the RISK assessment documentation to ensure that the RISKS have been eliminated or that only TOLERABLE RISKS remain.*

## Annex A (normative)

### Measuring circuits for touch current (see 6.3)

NOTE This annex is based on IEC 60990, which specifies procedures for measuring touch-current, and also specifies the characteristics for test voltmeters.

#### A.1 Measuring circuit for a.c. with frequencies up to 1 MHz and for d.c.

The current is measured using the circuit of Figure A.1. The current is calculated from:

$$I = \frac{U}{500}$$

where

$I$  is the current, in amperes;

$U$  is the voltage, in volts, indicated by the voltmeter.

This circuit represents the impedance of the body and compensates for the change of physiological response of the body with frequency.

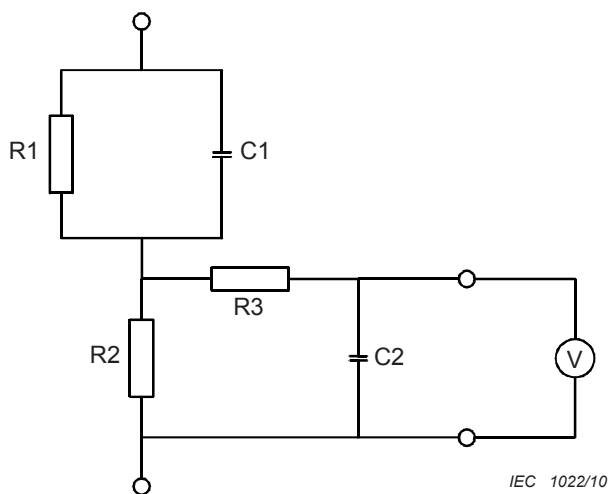

$R1 = 1\,500$  with a relative tolerance of 5 %

$R2 = 500$  with a relative tolerance of 5 %

$R3 = 10\,k$  with a relative tolerance of 5 %

$C1 = 0,22$  F with a relative tolerance of 10 %

$C2 = 0,022$  F with a relative tolerance of 10 %

**Figure A.1 – Measuring circuit for a.c. with frequencies up to 1 MHz and for d.c.**

## A.2 Measuring circuits for sinusoidal a.c. with frequencies up to 100 Hz and for d.c.

If the frequency does not exceed 100 Hz, the current may be measured using either of the circuits of Figure A.2. When using the voltmeter, the current is calculated from:

$$I = \frac{U}{2\,000}$$

where

$I$  is the current in amperes;

$U$  is the voltage, in volts, indicated by the voltmeter.

The circuit represents the impedance of the body for frequencies not exceeding 100 Hz.

NOTE The value 2 000 includes the impedance of the measuring instrument.

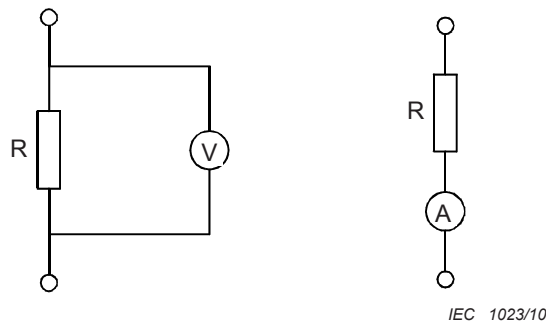

$R = 2\,000$  with a relative tolerance of 5 %

**Figure A.2 – Measuring circuits for sinusoidal a.c. with frequencies up to 100 Hz and for d.c.**

## A.3 Current measuring circuit for electrical burns at high frequencies

The current is measured using the circuit of Figure A.3. The current is calculated from:

$$I = \frac{U}{500}$$

where

$I$  is the current in amperes;

$U$  is the voltage, in volts, indicated by the voltmeter.

This circuit compensates for the effects of high frequency on the physiological response of the body.

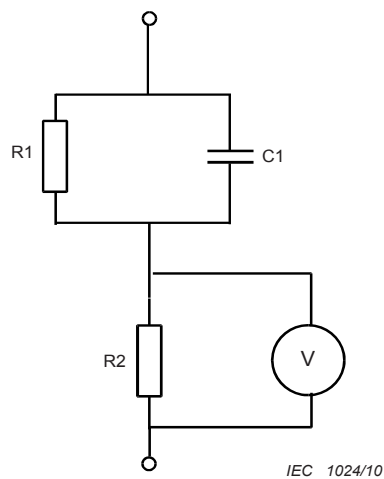

R1 = 1 500    with a relative tolerance of    5 %

R2 = 500    with a relative tolerance of    5 %

C1 = 0,22    F with a relative tolerance of    10 %

**Figure A.3 – Current measuring circuit for electrical burns**

#### **A.4    Current measuring circuit for WET LOCATION**

For WET LOCATION the current is measured using the circuit of Figure A.4. The current is calculated from:

$$I = \frac{U}{500}$$

where

$I$  is the current in amperes;

$U$  is the voltage, in volts, indicated by the voltmeter.

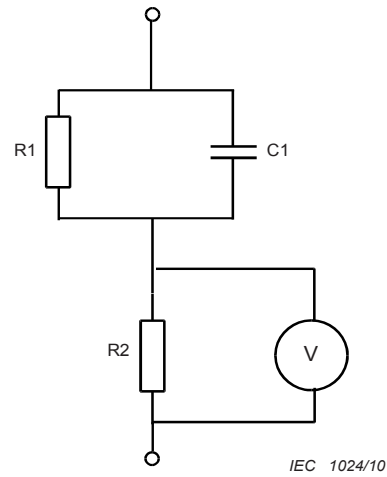

R1 = 375 with a relative tolerance of 5 %

R2 = 500 with a relative tolerance of 5 %

C1 = 0,22 F with a relative tolerance of 10 %

**Figure A.4 – Current measuring circuit for wet contact**

**Annex B**  
(normative)

**Standard test fingers**  
(see 6.2)

*Dimensions in millimetres*

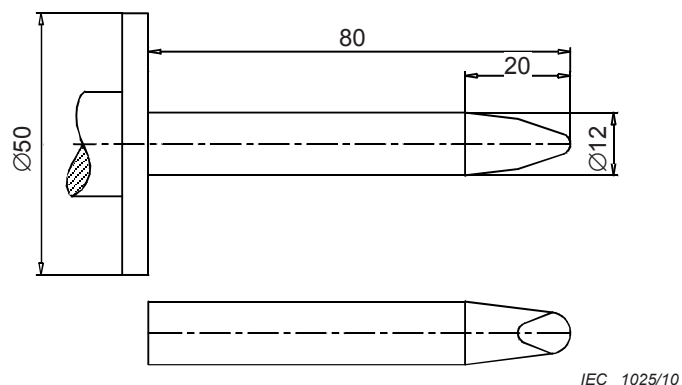

NOTE 1 For tolerances and dimensions of the fingertip, see Figure B.2.

NOTE 2 This test finger is the same as test probe 11 of IEC 61032:1997, Figure 7.

**Figure B.1 – Rigid test finger**

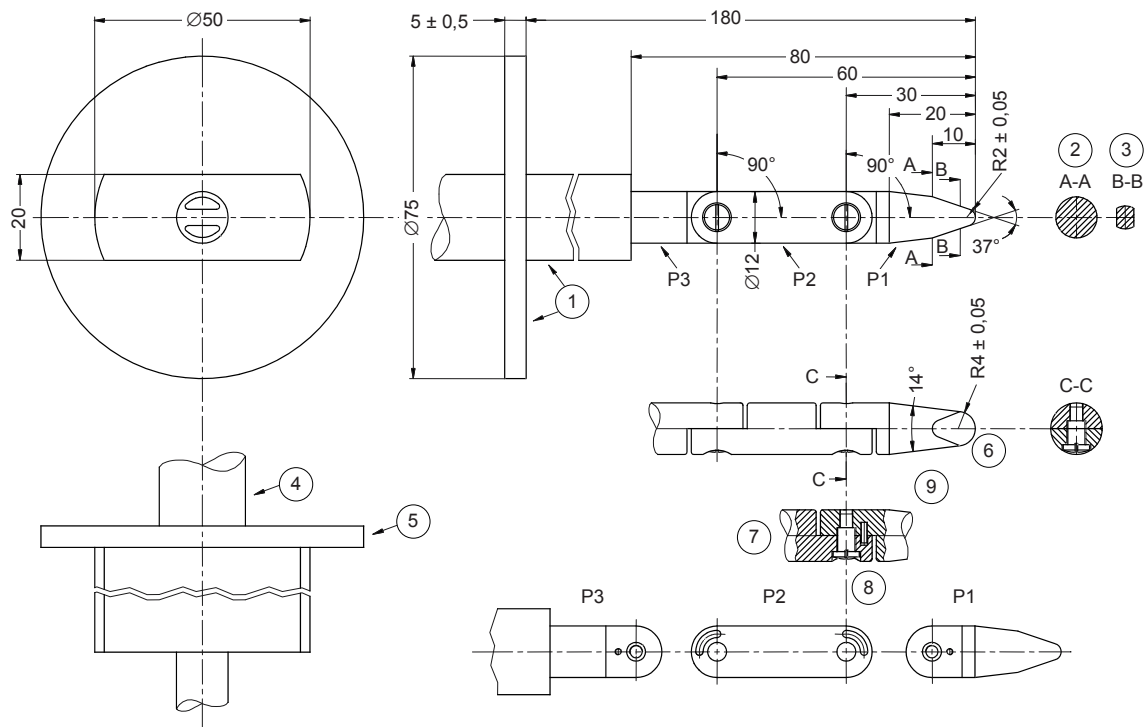

IEC 1026/10

Dimensions in millimetres

**Key**

- |   |                     |   |                    |
|---|---------------------|---|--------------------|
| 1 | insulating material | 6 | spherical          |
| 2 | section AA          | 7 | detail x (example) |
| 3 | section BB          | 8 | side view          |
| 4 | handle              | 9 | chamfer all edges  |
| 5 | stop plate          |   |                    |

Tolerances on dimensions without specific tolerance:

- on angles:  $\begin{matrix} 0 \\ -10^\circ \end{matrix}$
- on linear dimensions:
  - up to 25 mm:  $\begin{matrix} 0 \\ -0,05 \end{matrix}$  mm
  - over 25 mm:  $\pm 0,2$  mm

Material of finger: heat-treated steel, etc.

Both joints of this finger may be bent through an angle of  $(90 \begin{matrix} +10 \\ 0 \end{matrix})^\circ$ , but in one plane only.

Using the pin and groove solution is only one of the possible approaches in order to limit the bending angle to  $90^\circ$ . For this reason, dimensions and tolerances of these details are not given in the drawing. The actual design shall ensure a  $(90 \begin{matrix} +10 & +10 \\ 0 & 0 \end{matrix})^\circ$  bending angle.

NOTE This test finger is the same as test probe B of IEC 61032:1997, Figure 2.

**Figure B.2 – Jointed test finger**



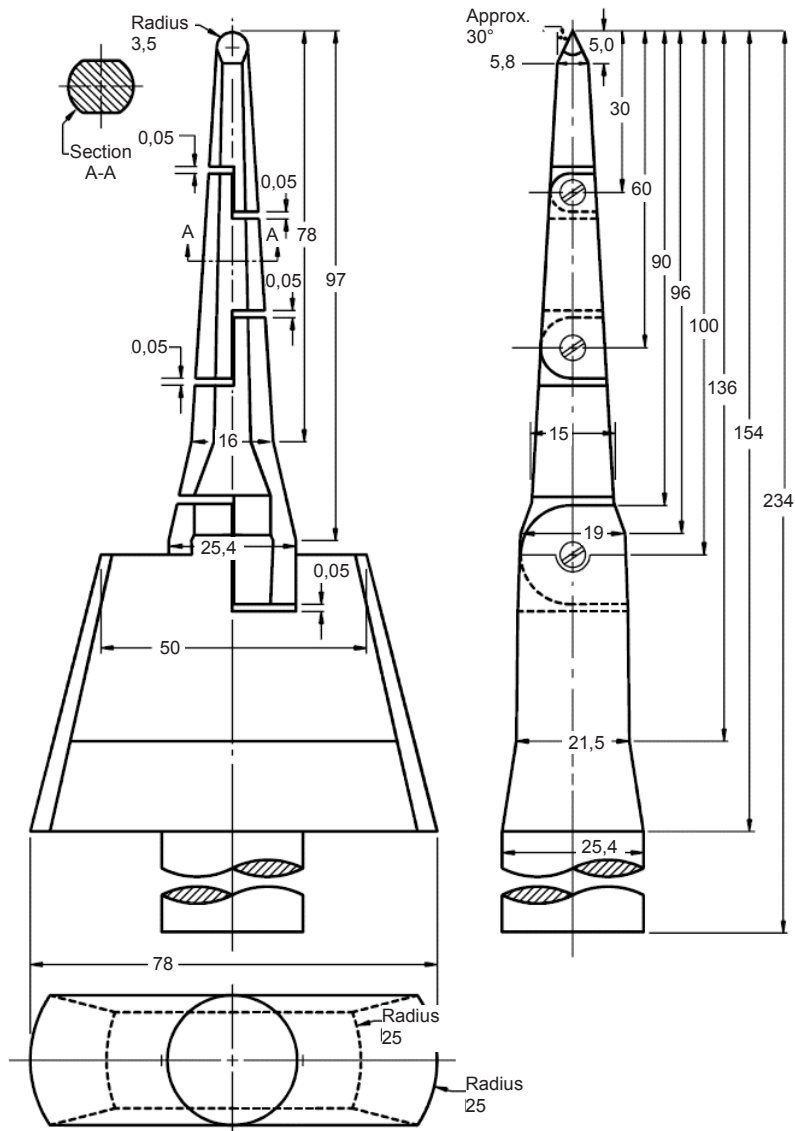

IEC 248/13

**NOTE 1** Linear dimensions in millimetres  
 Tolerances on dimensions without specific tolerance:

- on angles:  $\begin{matrix} 0 \\ -10' \end{matrix}$
- on linear dimensions:
  - up to 25 mm:  $\begin{matrix} 0 \\ -0,05 \end{matrix}$  mm
  - over 25 mm:  $\pm 0,2$  mm

Material of finger: \_\_\_\_\_ heat-treated steel, etc.

**NOTE 2** This test probe is identified in IEC 62368.

**Figure B.3 – Jointed test probe for equipment intended to be used by CHILDREN**

## Annex C (normative)

### Measurement of CLEARANCES and CREEPAGE DISTANCES

The methods of measuring CLEARANCES and CREEPAGE DISTANCES are indicated in the following examples 1 to 11 (see Figure C.1). These cases do not differentiate between gaps and grooves or between types of insulation.

The following assumptions are made:

- a) where the distance across a groove is equal to or larger than  $X$  (see Table C.1), the CREEPAGE DISTANCE is measured along the contours of the groove (see example 2);
- b) any recess is assumed to be bridged with an insulating link having a length equal to  $X$  and being placed in the least favourable position (see example 3);
- c) CLEARANCES and CREEPAGE DISTANCES measured between parts which can assume different positions in relation to each other are measured when these parts are in their least favourable position.

In the following examples dimension  $X$  has the value given in Table C.1 depending on the POLLUTION DEGREE.

**Table C.1 – Dimensions of  $X$**

POLLUTION DEGREE	Dimension $X$ mm
1	0,25
2	1,0
3	1,5

If the associated CLEARANCE is less than 3 mm, the dimension  $X$  in Table C.1 may be reduced to one-third of this CLEARANCE.

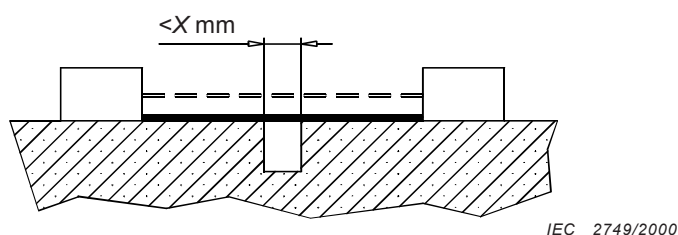

EXAMPLE 1 The path includes a parallel- or converging-sided groove of any depth with a width less than  $X$ . The CLEARANCE and the CREEPAGE DISTANCE are measured directly across the groove as shown.

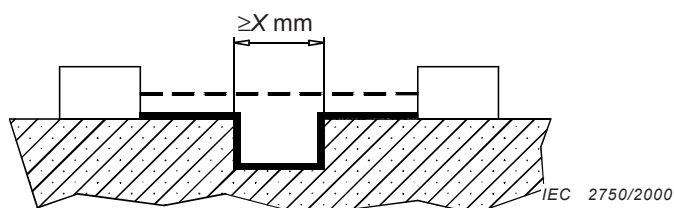

EXAMPLE 2 The path includes a parallel-sided groove of any depth and equal to or more than  $X$ . The CLEARANCE is the “line-of-sight” distance. The CREEPAGE DISTANCE follows the contour of the groove.

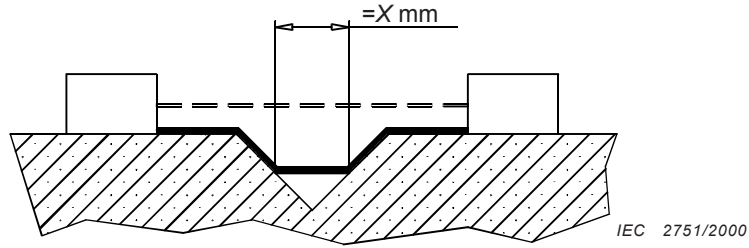

EXAMPLE 3 The path includes a V-shaped groove with a width greater than X.

The CLEARANCE is the "line-of-sight" distance. The CREEPAGE DISTANCE follows the contour of the groove but "short-circuits" the bottom of the groove by X link.

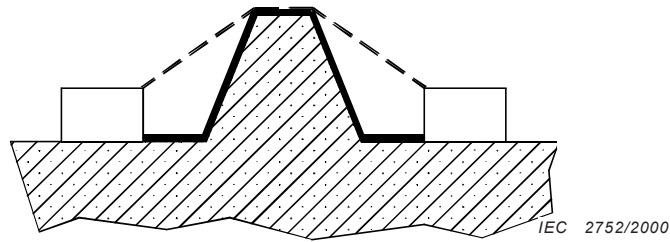

EXAMPLE 4 The path includes a rib.

The CLEARANCE is the shortest direct air path over the top of the rib. The CREEPAGE DISTANCE follows the contour of the rib.

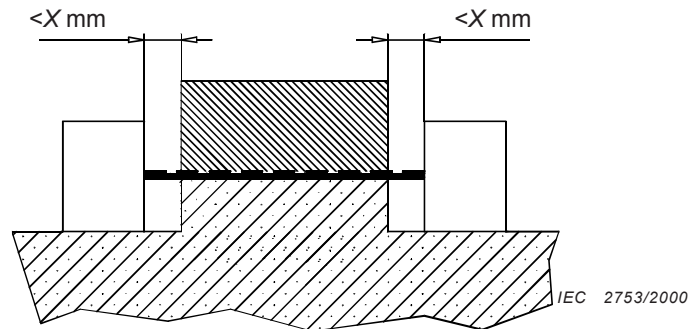

EXAMPLE 5 The path includes an uncemented joint with grooves less than X wide on each side.

The CLEARANCE and the CREEPAGE DISTANCE path is the "line-of-sight" distance shown.

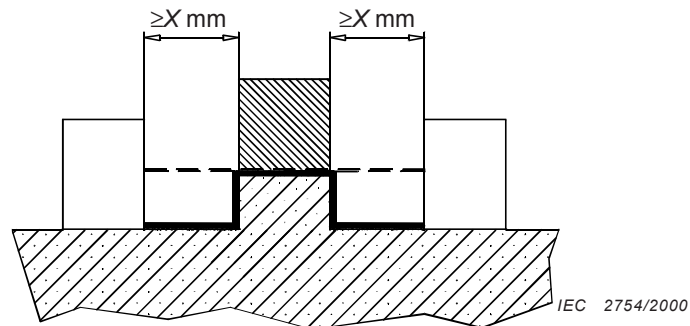

EXAMPLE 6 The path includes an uncemented joint with grooves equal to, or more than, X.

The CLEARANCE is the "line-of-sight" distance.

The CREEPAGE DISTANCE follows the contour of the grooves.

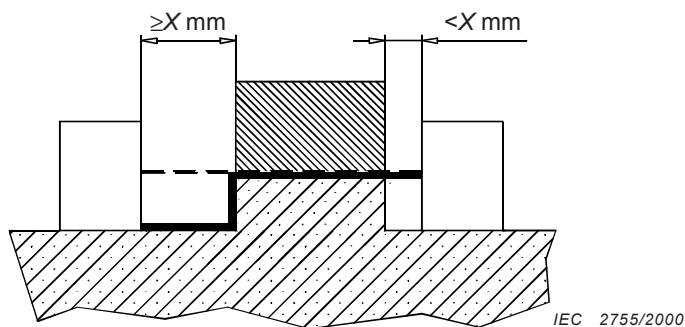

EXAMPLE 7 The path includes an uncemented joint with a groove on one side less than  $X$  wide and the groove on the other side equal to, or more than,  $X$  wide.

The CLEARANCE and the CREEPAGE DISTANCE are as shown.

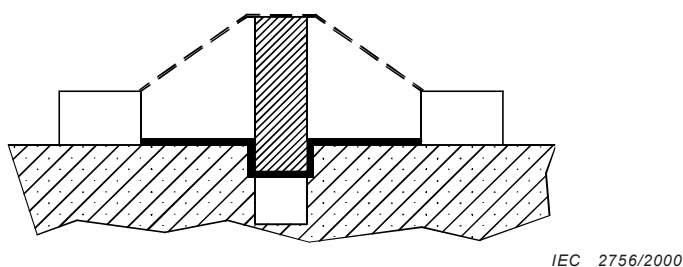

EXAMPLE 8 The CREEPAGE DISTANCE through the uncemented joint is less than the CREEPAGE DISTANCE over the barrier.

The CLEARANCE is the shortest direct air path over the top of the barrier.

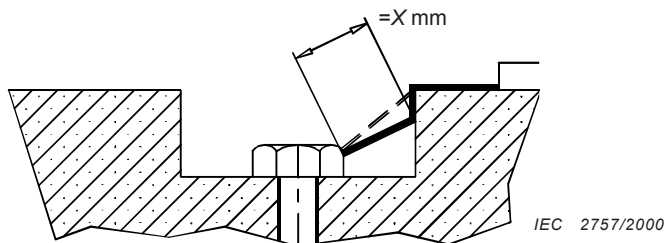

EXAMPLE 9 The gap between the head of the screw and the wall of the recess too narrow to be taken into account.

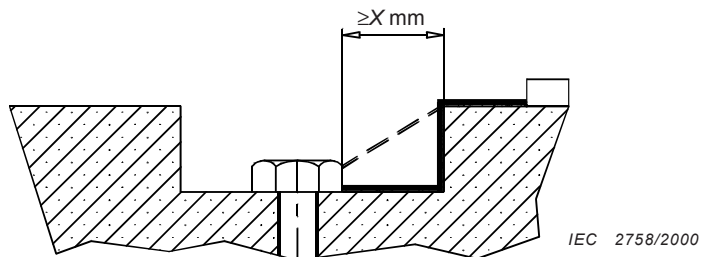

EXAMPLE 10 The gap between the head of the screw and the wall of the recess wide enough to be taken into account.

Measurement of the CREEPAGE DISTANCE is from screw to wall when the distance is equal to  $X$ .

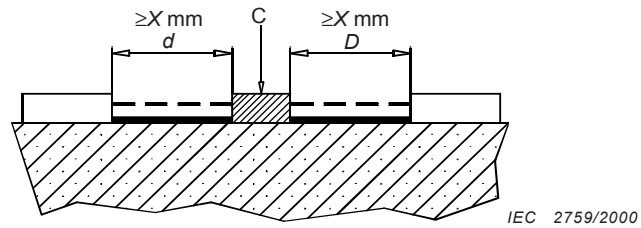

EXAMPLE 11 C = floating part

The CLEARANCE is the distance  $d + D$ . The CREEPAGE DISTANCE is also  $d + D$ .

———— CREEPAGE DISTANCE

- - - - CLEARANCE

**Figure C.1 – Examples of methods of measuring CLEARANCES and CREEPAGE DISTANCES**

**Annex D**  
(normative)

**Parts between which insulation requirements are specified**  
(see 6.4 and 6.5.3)

The following symbols are used in Figures D.1 to D.3 to indicate:

a) Requirements:

- B BASIC INSULATION is required
- D DOUBLE INSULATION or REINFORCED INSULATION is required

b) Circuits and parts:

- A ACCESSIBLE part, not bonded to the PROTECTIVE CONDUCTOR TERMINAL
- H circuit that is HAZARDOUS LIVE in NORMAL CONDITION
- R high impedance which, in combination with BASIC INSULATION, forms a PROTECTIVE IMPEDANCE (see 6.5.4)
- S protective screen
- T<sub>A</sub> ACCESSIBLE external TERMINAL (not exceeding the values of 6.3.1 in NORMAL CONDITION)
- T<sub>N</sub> TERMINAL (which may exceed the values of 6.3.1 in NORMAL CONDITION, and therefore shall not be ACCESSIBLE)
- Z impedance of secondary circuit

The secondary circuits shown may also be regarded merely as parts.

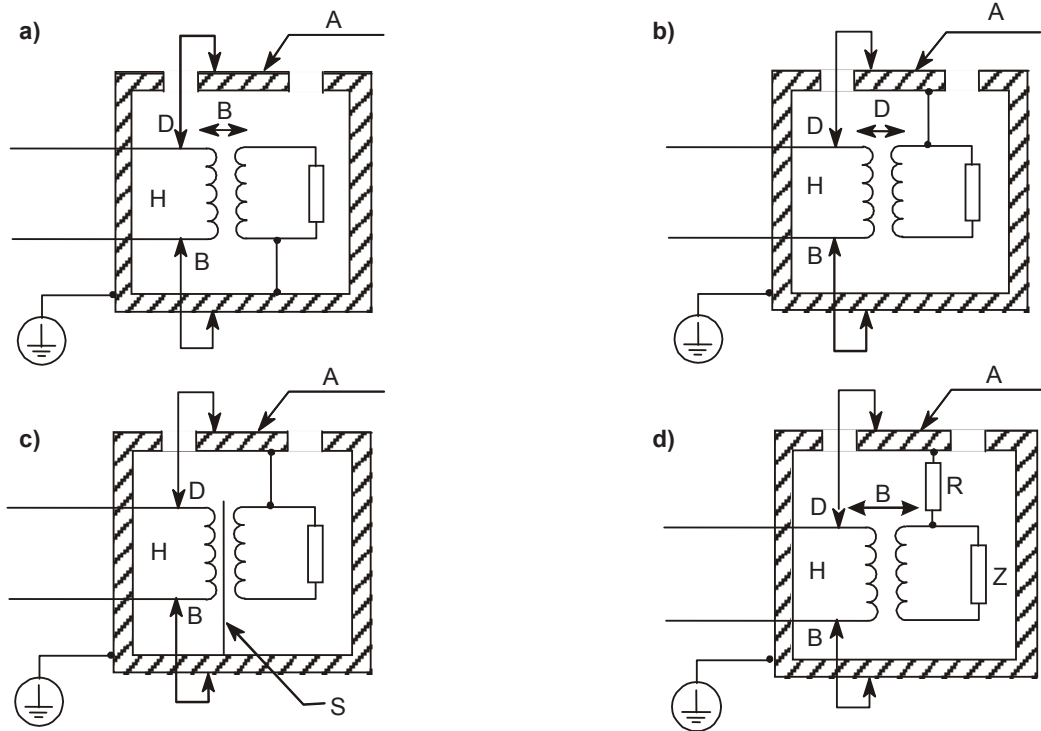

IEC 249/13

**Figures D.1 a) to d) – Protection between HAZARDOUS LIVE circuits and ACCESSIBLE parts**

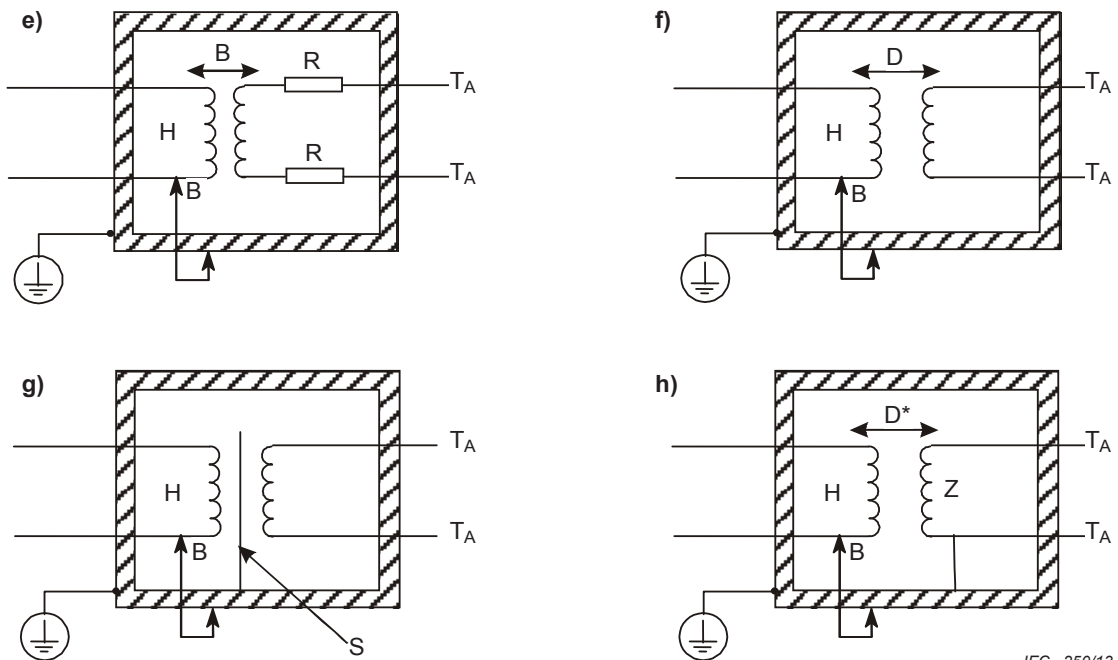

IEC 250/13

NOTE D\* may be B if Z is sufficiently low (see 6.6.1)

**Figures D.1 e) to h) – Protection between HAZARDOUS LIVE circuits and circuits which ACCESSIBLE external TERMINALS**



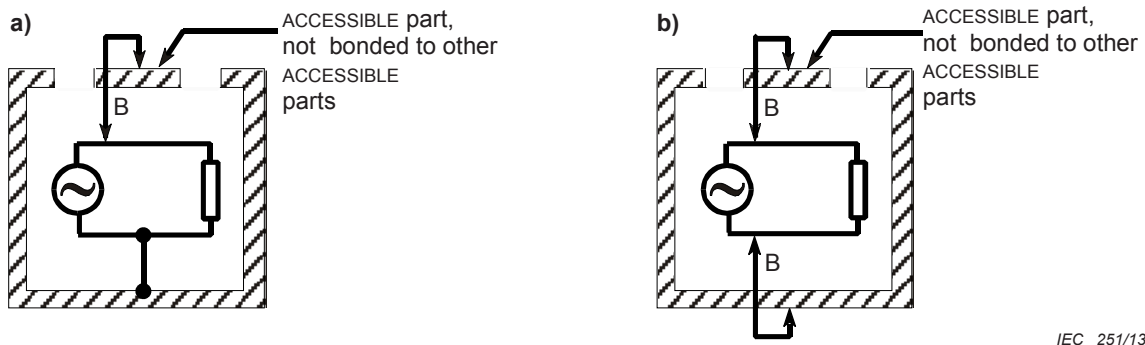

**Figures D.2 a) and b) – Protection between a HAZARDOUS LIVE internal circuit and an ACCESSIBLE part which is not bonded to other ACCESSIBLE parts**

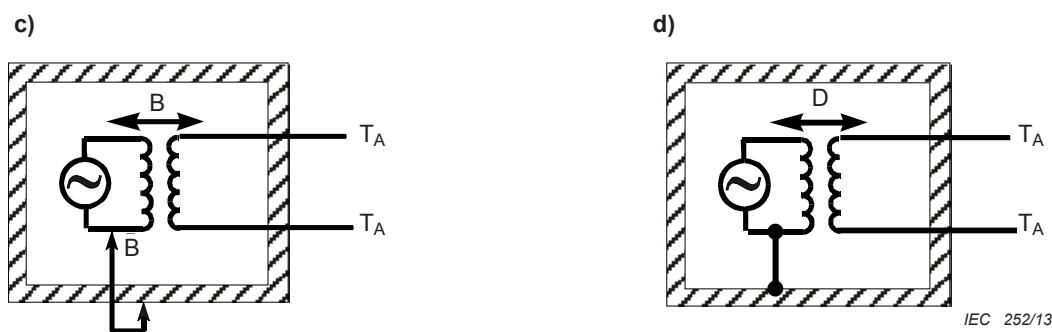

NOTE Other means of protection are also possible for the circuits shown in Figures D.2 c) and d), such as protective screening, PROTECTIVE BONDING of circuits (see 6.5.2) and PROTECTIVE IMPEDANCE (see 6.5.4).

**Figures D.2 c) and d) – Protection between a HAZARDOUS LIVE primary circuit and circuits which have ACCESSIBLE external TERMINALS**

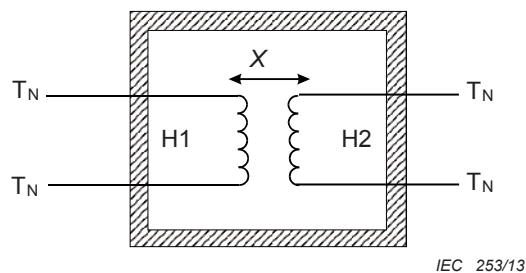

NOTE The requirement for insulation between an ACCESSIBLE part not bonded to the PROTECTIVE CONDUCTOR TERMINAL and either of these two HAZARDOUS LIVE circuits (H1 and H2) is as shown in D.1 a) to d).

**Figure D.3 – Protection of external ACCESSIBLE TERMINALS of two HAZARDOUS LIVE circuits**

The requirement for the insulation between H1 and H2 (X) is the most severe of the following:

- B BASIC INSULATION – If H1 and H2 are both connected, the insulation requirement is based on the highest RATED WORKING VOLTAGE that stresses the insulation between the circuits;
- D DOUBLE INSULATION or REINFORCED INSULATION – If H1 is connected and the TERMINALS of H2 are ACCESSIBLE for connection purposes, the insulation requirement is based on the highest RATED WORKING VOLTAGE that stresses the insulation of H1;
- D DOUBLE INSULATION or REINFORCED INSULATION – If H2 is connected and the TERMINALS of H1 are ACCESSIBLE for connection purposes, the insulation requirement is based on the highest RATED WORKING VOLTAGE that stresses the insulation of H2.

## Annex E (informative)

### Guideline for reduction of POLLUTION DEGREES

The micro-environment inside equipment is determined by the environmental conditions to which the equipment is exposed during operation, installation, maintenance, and any POLLUTION generated by the equipment itself as well as by the effectiveness of applied sealing measures.

Equipment can be divided into environmental situations as depicted in Table E.1.

**Table E.1 – Environmental situations**

Environmental situation	Equipment operated in ...	Installation or maintenance of equipment in ...
A	controlled environment <sup>a</sup>	controlled environment
B	uncontrolled environment	controlled environment or equipment is not opened during installation or maintenance
C	uncontrolled environment	uncontrolled environment

<sup>a</sup> A controlled environment is an environment having the conditions of 1.4.1 c) and d).

NOTE The environmental situation of Table E.1 provides a systematic classification of the environments to which the equipment is exposed and whether the equipment is opened for installation and maintenance purposes.

Reduction of the POLLUTION DEGREE of the micro-environment may be achieved by the methods of Table E.2.

**Table E.2 – Reduction of POLLUTION DEGREES**

POLLUTION DEGREE of macro environment	POLLUTION DEGREE of micro-environment						
	2			3		4	
	Environmental situation			Environmental situation		Environmental situation	
	A	B	C	B	C	B	C
ENCLOSURE IPx5, IPx6	1	2	2	3	3	4	4
ENCLOSURE IPx7, IPx8	1	1	2	2	3	2	4
Constant heating within the equipment with an ENCLOSURE of IPx4 or higher	1	2	2	3	3	4	4

IP RATINGS are according to IEC 60529.

## **Annex F** (normative)

### **ROUTINE TESTS**

#### **F.1 General**

The manufacturer shall perform the tests of F.2 to F.4 on 100 % of equipment produced which has both HAZARDOUS LIVE parts and ACCESSIBLE conductive parts. Unless it can be clearly shown that the result of the tests cannot be invalidated by subsequent manufacturing stages, tests shall be made with equipment fully assembled. Components shall not be unwired, modified or disassembled for the test, but snap-on covers and friction-fit knobs may be removed if they would interfere with the tests. The equipment shall not be energized during the tests, but the MAINS switch shall be in the on-position.

Wrapping the equipment in foil is not required, nor is humidity preconditioning necessary.

Test site altitude correction of the test voltage is not required.

The voltage test equipment shall be able to maintain the required voltage for the specified period of time. No other requirements apply.

*Conformity is checked by inspection.*

#### **F.2 Protective earth**

*A continuity test is made between the earth pin of the appliance inlet or the MAINS plug of plug-connected equipment, or the PROTECTIVE CONDUCTOR TERMINAL of PERMANENTLY CONNECTED EQUIPMENT on the one side, and all ACCESSIBLE conductive parts which are required by 6.5.2 to be connected to the PROTECTIVE CONDUCTOR TERMINAL on the other side.*

NOTE No value is specified for the test current.

#### **F.3 MAINS CIRCUITS**

##### **F.3.1 General**

*A test voltage is applied between:*

- a) the MAINS TERMINALS connected together, and
- b) all ACCESSIBLE conductive parts including the PROTECTIVE CONDUCTOR TERMINAL, if any, connected together.

*During this test, the equipment shall be electrically isolated from any external earthing. This test is not applied to small metal parts such as name plates, screws or rivets, if they are separated from parts which are HAZARDOUS LIVE by REINFORCED INSULATION or its equivalent.*

NOTE For equipment which has all ACCESSIBLE conductive parts connected to the PROTECTIVE CONDUCTOR TERMINAL, the interconnection of the ACCESSIBLE conductive parts is not necessary because the correct interconnections are tested by F.2.

*The test voltage may be a.c. or d.c. or impulse, and is selected from Table F.1 for the appropriate OVERVOLTAGE CATEGORY. For the a.c. and d.c. tests, the test voltage is raised to its specified value within 5 s, and maintained for at least 2 s. Impulse tests are the 1,2/50  $\mu$ s test specified in IEC 61180-1, conducted for a minimum of three pulses of each polarity at 1 s minimum intervals.*

*No flashover of CLEARANCES or breakdown of solid insulation shall occur during the test, nor shall the test device indicate failure.*

**Table F.1 – Test voltages for ROUTINE TESTS of MAINS CIRCUITS**

Nominal line-to-neutral voltage of MAINS supply	OVERVOLTAGE CATEGORY II			OVERVOLTAGE CATEGORY III			OVERVOLTAGE CATEGORY IV		
	a.c. r.m.s. or d.c.	a.c.	d.c.	1,2/50 $\mu$ s Impulse	a.c.	d.c.	1,2/50 $\mu$ s Impulse	a.c.	d.c.
V	V r.m.s.	V	V peak	V r.m.s.	V	V peak	V r.m.s.	V	V peak
$\leq 150$	840	1 200	1 200	1 400	2 000	2 000	2 200	3 100	3 100
$> 150 \leq 300$	1 400	2 000	2 000	2 200	3 100	3 100	3 300	4 700	4 700
$> 300 \leq 600$	2 200	3 100	3 100	3 300	4 700	4 700	4 300	6 000	6 000
$> 600 \leq 1\ 000$	3 300	4 700	4 700	4 300	6 000	6 000	5 300	7 500	7 500

### F.3.2 MAINS CIRCUITS with voltage limiting devices

*For MAINS CIRCUITS with voltage limiting devices that meet the requirements of 14.8, the a.c. or d.c. test of F.3.1 can be carried out using a test voltage of 0,9 times the clamping voltage of the voltage limiting device but not less than twice the WORKING VOLTAGE of the MAINS CIRCUIT.*

### F.4 Floating circuits

*A test voltage is applied between*

- a) *the TERMINALS of floating input and output circuits, which can be HAZARDOUS LIVE in NORMAL USE, connected together, and*
- b) *ACCESSIBLE conductive parts connected together.*

*The value of the applied voltage in each case is 1,5 times the maximum RATED voltage to earth but not less than 350 V a.c. r.m.s or 500 V d.c. If voltage-limiting (clamping) devices clamp below the applied voltage, the value of the applied voltage is 0,9 times the clamping voltage, but not less than that of the maximum RATED voltage to earth.*

*The test voltage is raised to its specified value within 5 s and maintained for at least 2 s, with the circuit electrically isolated from any external earthing means.*

*No flashover of CLEARANCES or breakdown of solid insulation shall occur during the test nor shall the test device indicate failure.*

## **Annex G** (informative)

### **Leakage and rupture from fluids under pressure**

#### **G.1 General**

The requirements and tests of this annex are accepted in the USA, Canada, and in some other countries, as proof of conformity with national regulations relating to high pressures. These requirements are not adequate for equipment intended for toxic, flammable, or otherwise hazardous materials. Refer to national authorities for requirements for such equipment.

Fluid-containing parts of equipment under pressure shall not cause a HAZARD through rupture or leakage in NORMAL CONDITION or SINGLE FAULT CONDITION.

*Conformity is checked as specified in G.2 to G.4.*

#### **G.2 Pressures above 2 MPa and a product pressure and volume greater than 200 kPa·l**

##### **G.2.1 General**

Fluid-containing parts of equipment which in NORMAL USE have both of the following characteristics shall not cause a HAZARD through rupture or leakage:

- a) a product of pressure and volume greater than 200 kPa·l;
- b) a pressure above 2 MPa.

NOTE Such equipment includes fluid-pressure-actuated equipment employing flexible bellows, diaphragms, Bourdon tubes, etc. and equipment such as flowmeters that are connected to process pressures RATED at or above 2 MPa.

*Conformity is checked by inspection and by performing the hydrostatic tests of G.2.2 to G.2.6. Any overpressure safety device which is used to limit the maximum working pressure is inactivated during the tests.*

Figure G.1 is a flow chart showing methods of conformity verification.

Throughout G.2, values are based on RATED pressure  $P_R$ . This is the maximum pressure as marked on the equipment or, if no value is marked, the maximum transient overpressure (maximum pressure which may be applied without permanent change in performance). In the case of differential pressure equipment, the RATED pressure is the higher of the working pressure and the static pressure.

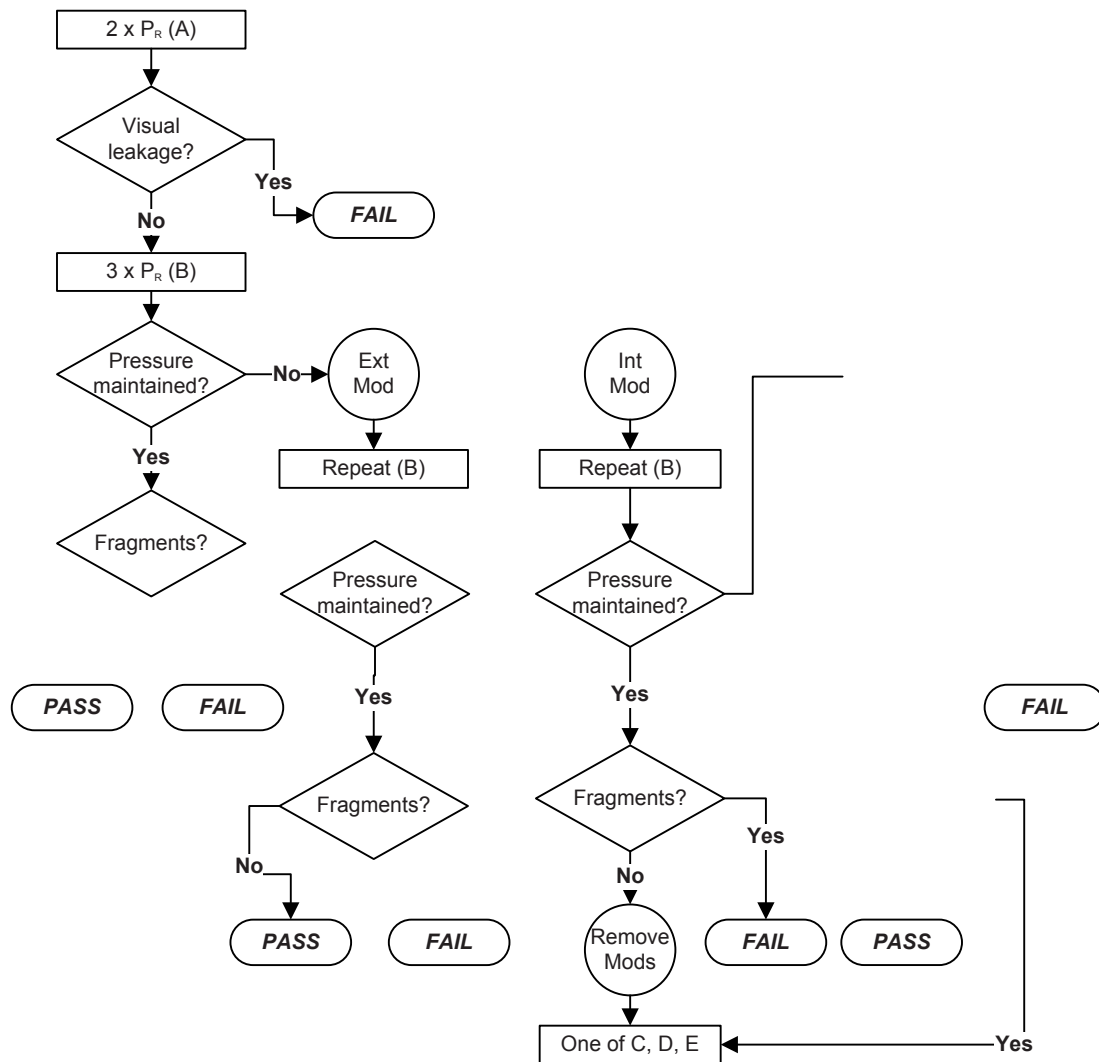

IEC 1030/10

NOTE Subclause references for tests A to F:

A = G.2.3 a) – B = G.2.3 b) – C = G.2.5 a) – D = G.2.5 b) – E = G.2.5 c) – F = G.2.6 –  $P_R$  = RATED pressure

**Figure G.1 – Conformity verification process (see G.2)**

### G.2.2 Conduct of hydrostatic tests for G.2.1

*The part of the equipment that is normally subjected to the fluid pressure is filled with a suitable liquid, such as water, to exclude air, and is then connected to a hydraulic pump. The pressure is raised gradually to the specified test pressure.*

*Those portions of the equipment which normally receive indirect pressure loading, as in hydraulically coupled systems, are subjected to the test pressure at the same time, either through the original hydraulic filling fluid or, in its absence, by filling with the test liquid.*

Test pressure values are based on RATED pressure  $P_R$ , see G.2.1.

Test pressure values specified in G.2.3 to G.2.6 apply to equipment with RATED pressure up to 14 MPa. For higher RATED pressures the values of Table G.1 apply.

If it is specified that pressure is applied to “the equipment”, this refers to that part of the equipment that is subjected to pressure in NORMAL USE. If it is specified that pressure is applied to “the outer casing” this refers to any unpressurized case, cover or housing that encloses all or part of the pressurized equipment, but that is not itself subjected to pressure in NORMAL USE.

### G.2.3 Initial tests

The following tests are performed.

- a) A pressure of  $2 \times P_R$  is applied to the equipment for 1 min without any visible leakage.
- b) A pressure of  $3 \times P_R$  is applied to the equipment for 1 min without any rupture or failure which results in fragments flying outside the equipment.

During test b), leakage may occur because of splits in Bourdon tubes, diaphragms, or bellows, or because of joint or gasket failure. These are not considered to be test failures if the pressure can be maintained for 1 min. However, if leakage is at a rate which prevents pressure being maintained for 1 min, the modifications specified in G.2.4 may be made, and the test repeated.

- 1) If the equipment passes the test of G.2.3 b) after modification only as specified in G.2.4 a), no further tests are performed.
- 2) If the equipment passes the test of G.2.3 b) after modification as specified in G.2.4 b), the modifications are removed, and one of the tests of G.2.5 is performed.
- 3) If the equipment again fails the test of G.2.3 b), the modifications are removed and the test of G.2.6 is performed.

### G.2.4 Modifications to minimize leakage

The following modifications may be made.

- a) External fittings may be modified to reduce leakage.
- b) A leaking gasket or a flexible seal (not part of the measuring element) which forms a structural partition between the part of the equipment that is under pressure in NORMAL USE and the outer casing may be replaced by a stronger non-functional member to reduce leakage.

### G.2.5 Additional tests if modification succeeded in minimizing leakage

If any modification as specified in G.2.4 b) was made before successfully repeating the test of G.2.3 b), the equipment is restored to its original state, and one of tests a), b) or c) below is performed on the unmodified equipment. For equipment intended for toxic, flammable or otherwise hazardous substances, test a) is performed.

- a) A pressure of  $2,5 \times P_R$  is applied to the equipment for 1 min without any visible leakage.
- b) A pressure of  $3 \times P_R$  is applied to the equipment for 1 min without any rupture or failure which results in fragments flying outside the outer casing.

NOTE 1 In this case, even if the pressure of  $3 \times P_{RATED}$  cannot be maintained within the equipment, leakage from the outer casing takes place at a rate which prevents a build-up of hazardous pressure.

- c) If the equipment has an outer casing capable of being pressurized, it is subjected to a pressure of  $P_R$  for 1 min without any rupture or failure which results in fragments flying outside the outer casing.

NOTE 2 In this situation, rupture and flying fragments are prevented by the capability of the outer casing to resist pressure.



### G.2.6 Additional test if modifications failed to reduce leakage

*If the equipment failed the test of G.2.3 b) after the modifications of G.2.4, but the leakage serves as a pressure relief mechanism, the equipment conforms to the requirements of G.2.3 b) if, after removal of the modifications, it passes the test specified below and, if the equipment has an outer casing, also passes one of tests a), b), and c) of G.2.5.*

*A pressure of  $2,5 \times P_R$  is applied to the equipment for 1 min without any rupture or failure which results in fragments flying outside the equipment.*

**Table G.1 – Test pressures for equipment with pressures above 14 MPa**

$P_R$	Pressure for test of G.2.5 c)	Pressure for test of G.2.3 a)	Pressure for tests of G.2.5 a) and G.2.6	Pressure for tests of G.2.3 b) and G.2.5 b)
$> 14 \leq 70$ MPa	$P_R$	$1,75 \times P_R$ plus 3,5 MPa	$2,0 \times P_R$ plus 7 MPa	$2,5 \times P_R$ plus 7 MPa
$> 70$ MPa	$P_R$	$1,3 \times P_R$ plus 35 MPa	$1,5 \times P_R$ plus 42 MPa	$2,0 \times P_R$ plus 42 MPa

### G.3 Pressures between 50 kPa and 2 MPa, and pressure times volume above 200 kPa·l

Fluid-containing parts of equipment which in NORMAL USE have both of the following characteristics shall not cause a HAZARD through rupture or leakage:

- a) a product of pressure and volume greater than 200 kPa·l;
- b) a pressure between 50 kPa and 2 MPa.

*Conformity is checked by a hydrostatic test conducted as specified in G.2.2. Any overpressure safety device which is used to limit the maximum working pressure is inactivated during the test.*

*A pressure of  $3 \times P_R$  is applied to the equipment for 1 min without leakage, permanent (plastic) deformation, or bursting. However, for equipment not intended for use with toxic, flammable, or otherwise hazardous substances, leakage at a gasket at a pressure above  $1,2 \times P_R$  is acceptable.*

*If a hydrostatic test cannot be performed on unmarked fluid-containing parts or pipes, their integrity is verified by suitable equivalent tests, such as pneumatic tests at  $3 \times P_R$ .*

*For refrigeration systems see applicable national standards for example ANSI/UL 471, CSA C22.2 No 120.*

### G.4 Pressures below 50 kPa, or pressure times volume below 200 kPa·l

Leakage from fluid-containing parts at lower pressures, or with a product of pressure and volume below 200 kPa·l, shall not cause a HAZARD.

*Conformity is checked by inspection of the RATINGS of parts and, if necessary, by subjecting the parts to a fluid pressure of twice the maximum pressure in NORMAL USE. The pressure is applied for 1 min. No leakage is to occur which could cause a HAZARD.*

## **G.5 Overpressure safety devices**

An overpressure safety device shall not operate in NORMAL USE and shall conform to all the following requirements.

- a) It shall be connected as close as possible to the fluid-containing parts of the system that it is intended to protect.
- b) It shall be installed so as to provide easy access for inspection, maintenance and repair.
- c) It shall not be capable of being adjusted without the use of a TOOL.
- d) It shall have its discharge outlet located and directed so that the released material is not directed towards any person.
- e) It shall have its discharge outlet located and directed so that operation of the device will not cause a HAZARD by depositing material that could cause deterioration of parts.
- f) It shall have sufficient discharge capacity to ensure that the pressure will not exceed  $1,1 \times P_R$  if there is a failure of the supply pressure control.
- g) There shall be no shut-off valve between any overpressure safety device and the parts that it is intended to protect.

Also see 11.7.4.

*Conformity is checked by inspection and test.*

## **Annex H** (normative)

### **Qualification of conformal coatings for protection against POLLUTION**

#### **H.1 General**

This annex covers requirements for conformal coatings used on printed wiring boards to reduce the POLLUTION DEGREE.

Conformal coatings shall meet the requirements of Clause H.2 and H.3.

NOTE 1 The requirements of Clause H.2 assure that the conformal coating has been suitably RATED for the purpose of coating printed wiring boards. The requirements of Clause H.3 assure that the coating will continue to adhere to the printed wiring board after environmental and physical stresses.

*Conformity is checked as specified in Clauses H.2 and H.3.*

NOTE 2 Conformal coatings that meet the requirements of ANSI/UL 746E are considered to meet these requirements.

#### **H.2 Technical properties**

The technical properties of conformal coatings shall be suitable for the intended application. In particular:

- a) the manufacturer of the coating material shall state that it is a coating for printed wiring boards;
- b) the RATED operating temperature range shall include the temperature range of the intended application;
- c) the comparative tracking index (CTI), the insulation resistance and the dielectric strength shall be suitable for the intended application;
- d) if the printed wiring board coating is to be exposed to sunlight, the coating shall have adequate UV resistance;
- e) the flammability RATING of the coating shall be at least the required flammability RATING of the printed wiring board to which it is applied.

*Conformity is checked by inspection of the manufacturer's data.*

#### **H.3 Qualification of coatings**



The coating shall meet the conformity requirements of Figure H.1 after the tests of Table H.1.

*Conformity is checked as specified in Table H.1 and Figure H.1, on 6 specimens of the coated printed wiring board.*

Table H.1 – Test parameters, test conditions and test procedures

Item	Test, conditioning	Test parameters and conditions	Test procedure
1	Scratch resistance	Temperature: 15 °C.... 35 °C Humidity: 45 %.... 75 % R.H. Any combination of temperature and humidity within these ranges is acceptable.	The scratch test is conducted according to 5.5 of IEC 60664-3, <u>Amendment 1:2010</u> .
2	Cold conditioning	Conditioning temperature: $T_{min}$ $T_{min}$ is the minimum RATED ambient temperature or the minimum RATED storage temperature, whichever is lower, of the specimen. Any humidity is acceptable. Conditioning time: 24 h	The specimens are placed in a temperature chamber and held at $T_{min}$ for the specified conditioning time.
3	Dry heat	Conditioning temperature: $T_{max}$ $T_{max}$ is the maximum RATED surface temperature, maximum RATED ambient temperature, or maximum RATED storage temperature, whichever is higher, of the specimen. Any humidity is acceptable. Conditioning time: 48 h	The specimen is placed in a temperature chamber and held at $T_{max}$ for the specified conditioning time.
4	Rapid change of temperature	Maximum temperature: $T_{max}$ $T_{max}$ is the maximum RATED surface temperature, maximum RATED ambient temperature, or maximum RATED storage temperature, whichever is highest, of the specimen. Minimum temperature: $T_{min}$ $T_{min}$ is the minimum RATED ambient temperature or the minimum RATED storage temperature, whichever is lower, of the specimen. Rate of change of temperature: within 30 s. Cycle time (duration of one cycle): $T_{max}$ and $T_{min}$ are each held until steady state conditions of the specimens are achieved and then maintained for 10 min. The cycle starts when the specimen has reached the target within 2° C. Number of cycles: 5 cycles	The conditioning procedure follows test Na of IEC 60068-2-14.
5	Damp heat	Temperature: 40 °C ± 2 °C Humidity: 90 %...95 % R.H. Conditioning time: 24 h	The specimens are placed in the humidity chamber and held at the specified temperature and humidity for the specified conditioning time.
6	Adhesion of coating	Temperature: 15 °C.... 35 °C Humidity: 45 %.... 75 % R.H. Pull force: 5 N	The test procedure follows the test described in 5.8.2 of IEC 60664-3:2003 using the specified pull force.
7	Humidity conditioning	Temperature: 40 °C ± 2 °C Humidity: 90 %...95 % R.H. Conditioning time: 48 h	The specimens are placed in the humidity chamber and held at the specified temperature and humidity for the specified conditioning time.
8	Insulation resistance of conductors	Temperature : 40 ± 2 °C Humidity: 90 %...95 % R.H. Insulation resistance: ≥ 100 MΩ	Insulation resistance is measured between the two outer conductors with the smallest CREEPAGE DISTANCE for at least 1 min. The test voltage shall be as close to the WORKING VOLTAGE as possible.

Figure H.1 (below) describes the test sequence and conformity.

<b>Preparation and scratch resistance</b>	
Preparation of the test specimens	Each specimen is to be assembled in the normal manner, using the normal soldering procedure, including any cleaning and protection steps that are normally applied.
Table H.1, item 1	Scratch resistance test
Visual inspection	<p>Conformity is checked by inspection.</p> <p>The specimens shall show no:</p> <ul style="list-style-type: none"> <li>– separation from base material,</li> <li>– cracks,</li> <li>– voids,</li> <li>– areas with adjacent unprotected conductive parts where the creepage distance between the parts is less than the required creepage distance for uncoated printed wiring boards.</li> </ul> <p><i>NOTE Areas of the specimens where scratch resistance test is applied need not be involved in the subsequent testing and inspection.</i></p>
	
<b>Conditioning of the test specimens</b>	
Table H.1, item 2	Cold conditioning
Table H.1, item 3	Dry heat
Table H.1, item 4	Rapid change of temperature
Table H.1, item 5	Damp heat test
	
<b>Mechanical and electrical tests after conditioning</b>	
Table H.1, item 6	Adhesion of coating (tape test)
Visual inspection	<p>Conformity is checked by inspection.</p> <p>On all specimens, the coating shall not have loosened and there shall be no material transferred to the tape that is visible to the naked eye.</p> <p><i>NOTE In order to assess whether there has been any transfer of material, the tape can be placed on a sheet of white paper or card. If a white or light-coloured coating is being tested, a suitably contrasting coloured paper or card is used instead.</i></p>
Table H.1, item 7	Humidity conditioning
Table H.1, item 8	<p>Insulation resistance</p> <p><i>Conformity is checked by measuring of the insulation resistance of Table H.1, item 8. All specimens shall meet the required value.</i></p>
	
Visual inspection	<p><i>Conformity is checked by inspection.</i></p> <p>All specimens shall show no</p> <ul style="list-style-type: none"> <li>– blistering,</li> <li>– swelling,</li> <li>– separation from base material,</li> <li>– cracks,</li> <li>– voids,</li> <li>– areas with adjacent unprotected conductive parts where the CREEPAGE DISTANCE between the parts is less than the required CREEPAGE DISTANCE for uncoated printed wiring boards.</li> </ul>

**Figure H.1 – Test sequence and conformity**

## Annex I (informative)

### Line-to-neutral voltages for common MAINS supply systems

For the purposes of this Technical Specification, Table I.1 gives the line-to-neutral voltage that should be used for determining CLEARANCE, CREEPAGE DISTANCE, and solid insulation requirements of MAINS circuits.

**Table I.1 – Line-to-neutral voltages for common MAINS supply systems**

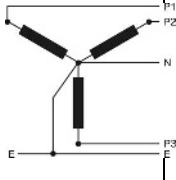
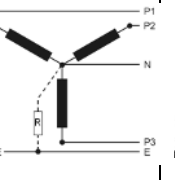
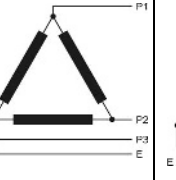
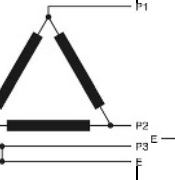
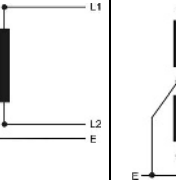
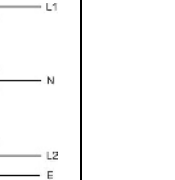
MAINS systems and nominal voltages						Line-to-neutral voltage pertinent to MAINS system type and nominal voltage
Three-phase four-wire systems <sup>a</sup> with earthed neutral	Three-phase four-wire systems <sup>b</sup> with unearthed neutral (IT networks) <sup>c</sup>	Three-phase three-wire systems unearthed	Three-phase three-wire systems with earthed phase	Single-phase two-wire systems a.c. or d.c.	Single-phase (split-phase) three-wire systems <sup>a</sup> a.c. or d.c.	
						V
V	V	V	V	V	V	V
				12,5 to 48	30/60	50
66/115		66	100	60	100/200	100
120/208 127/220		110, 115 120, 127	120	110, 115 120, 127	110/220 115/230 120/240	150
220/380 230/400 240/415 260/440 277/480	120/208 230/400 277/480	220, 230, 240 260, 277, 347 380, 400, 415 440, 480	200, 240	220 230 240	220/440 240/480	300
347/600 380/660 400/690 417/720 480/830	347/600	500 577 600	347, 380, 400, 415, 440, 480, 600	480	480/960	600
	400/690	660 690, 720 830, 1 000		1 000		1 000

<sup>a</sup> Voltages shown as two voltages separated by a "/" represent the phase-to-neutral (or line-to-neutral) voltage followed by the phase-to-phase (or line-to-line) voltage. For example, "120/208" indicates that the voltage from any phase to neutral is 120 V, and the voltage from any phase to another phase is 208 V. Likewise, "220/440" indicates that the voltage from either line-to-neutral is 220 V, and the voltage from line-to-line is 440 V.

<sup>b</sup> R is an impedance which may connect neutral to earth (usually 1 500 Ω).

<sup>c</sup> When insulation is monitored, neutral of these systems is considered to be earthed.

## Annex J (informative)

### Risk assessment

#### J.1 Risk assessment procedure

A RISK assessment procedure based on ISO/IEC Guide 51 (1999) is given below. Other RISK assessment procedures are contained in ISO 14971, SEMI S10, IEC 61508, ISO 14121-1, and ANSI TR3. Other established procedures which implement similar steps can also be used.

TOLERABLE RISK is achieved by the iterative process of RISK assessment (RISK analysis and RISK evaluation) and RISK reduction (see Figure J.1).

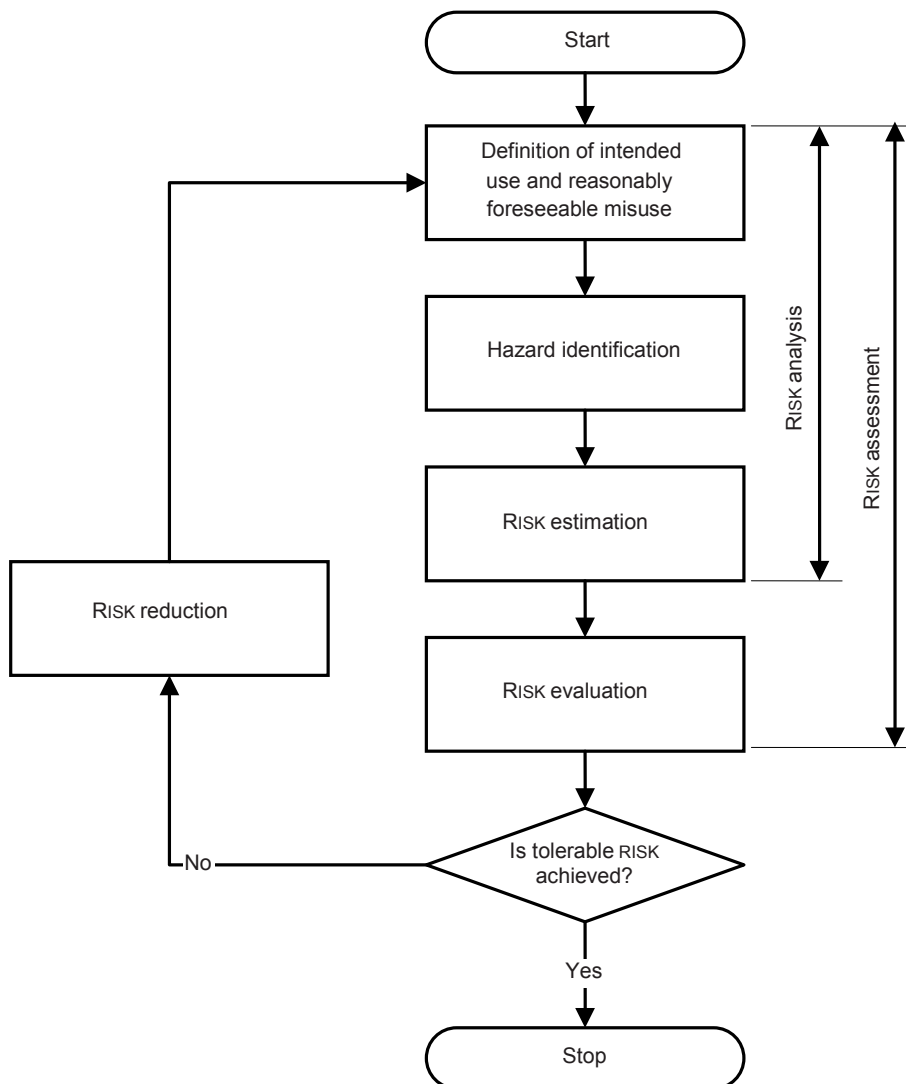

IEC 254/13

Figure J.1 – Iterative process of RISK assessment and RISK reduction

## J.2 Achieving TOLERABLE RISK

The following procedure (see Figure J.1) should be used to reduce RISKS to a tolerable level:

- a) identify the likely user group(s) for the product, process, or service (including those with special needs and the elderly), and any known contact group (e.g. use or contact by children);
- b) identify the intended use and assess the REASONABLY FORESEEABLE MISUSE of the product, process or service;
- c) identify each HAZARD (including any hazardous situation and harmful event) arising in all stages and conditions for the use of the product, process or service, including installation, maintenance, repair, and destruction or disposal;
- d) estimate and evaluate the RISK (see Figure J.1) to each identified user/contact group arising from each HAZARD identified;
- e) judge if the RISK is tolerable (e.g. by comparison with similar products, processes or services);
- f) if the RISK is not tolerable, reduce the RISK until it becomes tolerable.

When reducing RISKS the order of priority should be as follows:

- 1) eliminate or reduce RISKS as far as possible (inherently safe design and construction);
- 2) take the necessary protection measures in relation to RISKS that cannot be eliminated (protection devices);
- 3) inform users of the residual RISKS due to any shortcomings of the protection measures adopted, indicate whether any particular training is required, and specify any need to provide personal protection equipment (information for safety).

This procedure is based on the assumption that the user has a role to play in the RISK reduction procedure by complying with the information provided by the manufacturer (see Figure J.2).

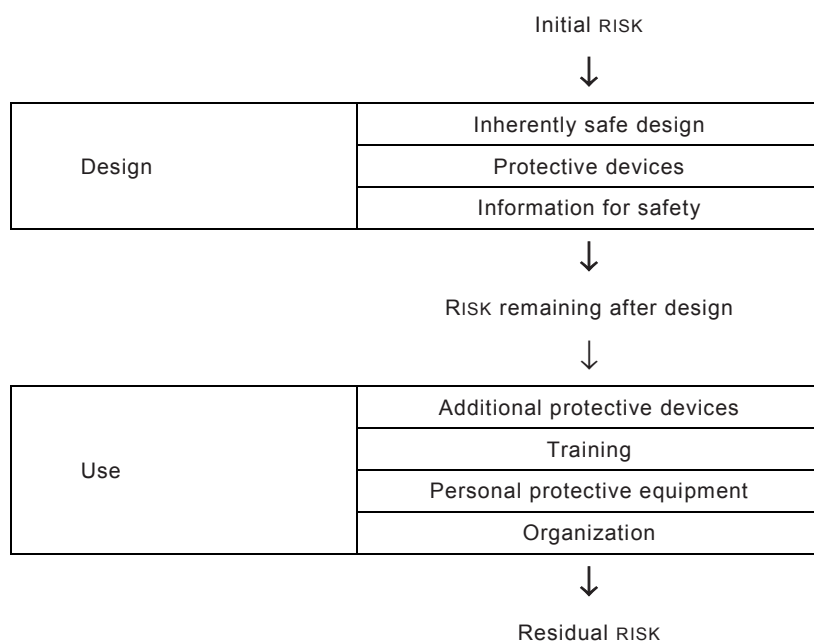

IEC 255/13

**Figure J.2 – Risk reduction**

The steps taken in the design procedure are shown in order of priority. The steps to be taken by the user are not in order of priority because this would depend on the application. It is



emphasized that the additional protection devices, personal protection equipment and provision of information to users should not be used as substitutes for design improvements.

### J.3 An application of RISK assessment procedures

For HAZARDS in the scope of this Technical Specification, examples of severity of harm are given in Table J.1. Probability of harm is given in Table J.2. The RISK category, which is selected based on severity and probability, is given in Table J.3.

**Table J.1 – Severity of harm**

Severity group	People	Equipment / Facility	Environment
Catastrophic	One or more fatalities	System or facility loss	Chemical release with acute or public health impact
Severe	Disabling injury/illness	Major subsystem loss or facility damage	Chemical release with temporary environmental or public health impact
Moderate	Medical treatment or restricted work activity	Minor subsystem loss or facility damage	Chemical release triggering external reporting requirements
Minor	First aid only	Non-serious equipment or facility damage	Chemical release requiring only routine cleanup without reporting

**Table J.2 – Probability of harm**

Likelihood	Expected rate of occurrence
Frequent	More than five times a year
Likely	More than once per year, but not more than five times a year
Possible	More than once in five years, but not more than one a year
Rare	More than once in ten years, but not more than one in five years
Unlikely	No more than once in ten years

**Table J.3 – Risk category**

Risk assessment / RISK category						
Severity of harm		Probability of harm				
		Frequent	Likely	Possible	Rare	Unlikely
Severity	Catastrophic	3	3	3	2	2
	Severe	3	3	2	2	1
	Moderate	3	2	1	1	1
	Minor	2	1	1	1	1
Key	Category	Description				
1	Broadly acceptable	This fulfils the requirement for TOLERABLE RISK.				
2	As low as reasonably practicable	This does not automatically fulfil the requirement for TOLERABLE RISK. If possible, these RISKS should be reduced further to Category 1. If not possible, then the instructions should contain a description of the RISK so that the RESPONSIBLE BODY can take appropriate steps to protect the safety of OPERATORS.				
3	Intolerable	This contains RISKS that are not TOLERABLE RISKS.				

## Annex K (normative)

### Insulation requirements not covered by 6.7

#### K.1 Requirements for MAINS CIRCUITS

##### K.1.1 General

The concept of OVERVOLTAGE CATEGORIES is elaborated in IEC 60364 and in IEC 60664-1. The descriptions below are made up of edited extracts from these two standards.

An OVERVOLTAGE CATEGORY is, as stated in 3.5.17, a numeral defining a TRANSIENT OVERVOLTAGE condition. The OVERVOLTAGE CATEGORIES are created to achieve insulation coordination between different parts of the MAINS supply installation. ~~IEC 60364-4-44:2007, 443.2.1 says that~~ “Impulse withstand (overvoltage) categories are provided to distinguish different degrees of availability of equipment with regard to required expectations on continuity of service and on an acceptable probability of failure”.

NOTE For further information see IEC 60364-4-44:2007, 3.2.1.

~~This means that~~ The decision of the appropriate RATING of the OVERVOLTAGE CATEGORY of a piece of equipment may be made on grounds of reliability as well as on grounds of safety. In this Technical Specification, requirements in Clauses 5 to 16 apply to equipment not forming part of the building installation, and the requirements for CLEARANCES and CREEPAGE DISTANCES are based on OVERVOLTAGE CATEGORY II, with MAINS voltages up to 300 V.

Equipment forming part of the building installation may include installation material, equipment intended to measure or control the MAINS supply within the building, and similar equipment. All such equipment is permanently connected to the MAINS, and is permanently installed in the building. However, equipment that utilizes the MAINS supply only for powering itself and associated equipment is not considered to be part of the building installation, even if it is permanently connected or permanently installed in the building.

If a manufacturer rates equipment for OVERVOLTAGE CATEGORY III or OVERVOLTAGE CATEGORY IV, the relevant requirements of this annex apply.

~~OVERVOLTAGE CATEGORY I is used, within the context of IEC 60364-4-44, for equipment intended to be connected to a MAINS supply in which means have been taken to substantially and reliably reduce TRANSIENT OVERVOLTAGES to a level where they cannot cause a HAZARD.~~ OVERVOLTAGE CATEGORY I is not relevant to this Technical Specification.

OVERVOLTAGE CATEGORY II is for equipment intended to be supplied from the building wiring. It applies both to plug-connected equipment and to PERMANENTLY CONNECTED EQUIPMENT. Subclause 6.7 covers only the requirements for OVERVOLTAGE CATEGORY II with a nominal supply voltage up to 300 V. The requirements for higher OVERVOLTAGE CATEGORIES and for OVERVOLTAGE CATEGORY II with a nominal supply voltage above 300 V are covered by this annex.

OVERVOLTAGE CATEGORY III is for equipment intended to form part of a building wiring installation. Such equipment includes socket outlets, fuse panels, and some MAINS installation control equipment. Manufacturers may also design equipment for OVERVOLTAGE CATEGORY III when a higher degree of reliability and availability is desired.

OVERVOLTAGE CATEGORY IV is for equipment installed at or near the origin of the electrical supply to a building, between the building entrance and the main distribution board. Such equipment may include electricity tariff meters and primary overcurrent protection devices.

Manufacturers may also design equipment for OVERVOLTAGE CATEGORY IV when an even higher degree of reliability and availability is desired.

### K.1.2 CLEARANCES and CREEPAGE DISTANCES for MAINS CIRCUITS

CLEARANCES and CREEPAGE DISTANCES for MAINS CIRCUITS shall meet the values of the following tables as applicable:

- a) for MAINS CIRCUITS of OVERVOLTAGE CATEGORY II, with nominal supply voltages above 300 V, Table K.2;
- b) for MAINS CIRCUITS of OVERVOLTAGE CATEGORY III, Table K.3;
- c) for MAINS CIRCUITS of OVERVOLTAGE CATEGORY IV, Table K.4.

NOTE See Annex I for nominal voltages of MAINS supplies.

The values in the following tables are for BASIC INSULATION and SUPPLEMENTARY INSULATION. Values for REINFORCED INSULATION shall be twice the values for BASIC INSULATION.

If the equipment is RATED to operate at an altitude greater than 2 000 m, the CLEARANCES shall be multiplied by the applicable factor of Table K.1.

NOTE 2—Material group IIIb is not recommended for application in POLLUTION DEGREE 3 above line-to-neutral voltages of 630 V.

*Conformity is checked by inspection and measurement.*

**Table K.1 – Multiplication factors for CLEARANCES for equipment RATED for operation at altitudes up to 5 000 m**

RATED operating altitude m	Multiplication factor
Up to 2 000	1,00
2 001 to 3 000	1,14
3 001 to 4 000	1,29
4 001 to 5 000	1,48

**Table K.2 – CLEARANCES and CREEPAGE DISTANCES for MAINS CIRCUITS of OVERVOLTAGE CATEGORY II above 300 V**

Voltage line-to- neutral a.c. r.m.s. or d.c.	Values for CLEAR- ANCE	Values for CREEPAGE DISTANCE								
		Printed wiring board material			Other insulating material					
		POLLUTIO N DEGREE 1	POLLUTION DEGREE 2	POLLUTION DEGREE 1	POLLUTION DEGREE 2			POLLUTION DEGREE 3		
		All material groups	Material groups I, II, IIIa	All material groups	Material I group I	Material group II	Material group III	Material group I	Material group II	Material group III
V	mm	mm	mm	mm	mm	mm	mm	mm	mm	mm
> 300 ≤ 600	3,0	3,0	3,0	3,0	3,0	4,3	6,0	7,5	8,3	9,4
> 600 ≤ 1 000	5,5	5,5	5,5	5,5	5,5	7,2	10,0	12,5	14,0	16,0

**Table K.3 – CLEARANCES and CREEPAGE DISTANCES for MAINS CIRCUITS of OVERVOLTAGE CATEGORY III**

Voltage line-to-neutral a.c. r.m.s. or d.c.	Values for CLEARANCE	Values for CREEPAGE DISTANCE								
		Printed wiring board material			Other insulating material					
		POLLUTION DEGREE 1	POLLUTION DEGREE 2	POLLUTION DEGREE 1	POLLUTION DEGREE 2			POLLUTION DEGREE 3		
		All material groups	Material groups I, II, IIIa	All material groups	Material group I	Material group II	Material group III	Material group I	Material group II	Material group III
V	mm	mm	mm	mm	mm	mm	mm	mm	mm	mm
≤150	1,5	1,5	1,5	1,5	1,5	1,5	1,6	2,0	2,2	2,5
> 150 ≤ 300	3,0	3,0	3,0	3,0	3,0	3,0	3,0	3,8	4,1	4,7
> 300 ≤ 600	5,5	5,5	5,5	5,5	5,5	5,5	6,0	7,5	8,3	9,4
> 600 ≤ 1 000	8,0	8,0	8,0	8,0	8,0	8,0	10,0	12,5	14,0	16

**Table K.4 – CLEARANCES and CREEPAGE DISTANCES for MAINS CIRCUITS of OVERVOLTAGE CATEGORY IV**

Voltage line-to-neutral a.c. r.m.s. or d.c.	Values for CLEARANCE	Values for CREEPAGE DISTANCE								
		Printed wiring board material			Other insulating material					
		POLLUTION DEGREE 1	POLLUTION DEGREE 2	POLLUTION DEGREE 1	POLLUTION DEGREE 2			POLLUTION DEGREE 3		
		All material groups	Material groups I, II, IIIa	All material groups	Material group I	Material group II	Material group III	Material group I	Material group II	Material group III
V	mm	mm	mm	mm	mm	mm	mm	mm	mm	mm
≤ 150	3,0	3,0	3,0	3,0	3,0	3,0	3,0	3,0	3,0	3,0
> 150 ≤ 300	5,5	5,5	5,5	5,5	5,5	5,5	5,5	5,5	5,5	5,5
> 300 ≤ 600	8,0	8,0	8,0	8,0	8,0	8,0	8,0	8,0	8,3	9,4
> 600 ≤ 1 000	14,0	14,0	14,0	14,0	14,0	14,0	14,0	14,0	14,0	16,0

Coatings that meet the requirements of Annex H when applied to the outer surfaces of printed wiring boards reduce the POLLUTION DEGREE of the coated area to POLLUTION DEGREE 1.

*Conformity of coatings is checked as specified in Annex H.*

### K.1.3 Solid insulation for MAINS CIRCUITS

#### K.1.3.1 General

Solid insulation of MAINS CIRCUITS shall withstand the electrical and mechanical stresses that may occur in NORMAL USE, in all RATED environmental conditions (see 1.4), during the intended life of the equipment.

**NOTE 1**—The manufacturer should take the expected life of the equipment into account when selecting insulating materials.

*Conformity is checked by both of the following tests:*

- a) the a.c. test of 6.8.3.1 with a duration of at least 5 s or the peak impulse test of 6.8.3.3 using the applicable voltages from Tables K.5, K.6 or K.7;
- b) the a.c. test of 6.8.3.1 with a duration of at least 1 min, or for MAINS CIRCUITS stressed only by d.c. the 1 min d.c. test of 6.8.3.2 using the applicable voltages from Table K.8.

**NOTE** These two different voltage tests ~~serve different purposes~~ are required for these circuits for the following reasons. Test a) checks the effects of TRANSIENT OVERVOLTAGES, while test b) checks the effects of long-term stress of solid insulation.

**NOTE 3**—If the test from Tables K.5 to K.7 is performed for at least 1 min, there is no need to repeat the test of b) above.

**Table K.5 – Test voltages for solid insulation in MAINS CIRCUITS of OVERVOLTAGE CATEGORY II above 300 V**

Voltage line-to-neutral a.c. r.m.s. or d.c.  V	Test voltage			
	5 s a.c. test V a.c. r.m.s.		Impulse test V peak	
	BASIC INSULATION and SUPPLEMENTARY INSULATION	REINFORCED INSULATION	BASIC INSULATION and SUPPLEMENTARY INSULATION	REINFORCED INSULATION
> 300 ≤ 600	2 210	3 510	4 000	6 400
> 600 ≤ 1 000	3 310	5 400	6 000	9 600

**Table K.6 – Test voltages for solid insulation in MAINS CIRCUITS of OVERVOLTAGE CATEGORY III**

Voltage line-to-neutral a.c. r.m.s. or d.c.  V	Test voltage			
	5 s a.c. test V r.m.s.		Impulse test V peak	
	BASIC INSULATION and SUPPLEMENTARY INSULATION	REINFORCED INSULATION	BASIC INSULATION and SUPPLEMENTARY INSULATION	REINFORCED INSULATION
≤ 150	1 390	2 210	2 500	4 000
> 150 ≤ 300	2 210	3 510	4 000	6 400
> 300 ≤ 600	3 310	5 400	6 000	9 600
> 600 ≤ 1 000	4 260	7 400	8 000	12 800

**Table K.7 – Test voltages for solid insulation in MAINS CIRCUITS  
of OVERVOLTAGE CATEGORY IV**

Voltage line-to-neutral a.c. r.m.s. or d.c.  V	Test voltage			
	5 s a.c. test V r.m.s.		Impulse test V peak	
	BASIC INSULATION and SUPPLEMENTARY INSULATION	REINFORCED INSULATION	BASIC INSULATION and SUPPLEMENTARY INSULATION	REINFORCED INSULATION
≤ 150	2 210	3 510	4 000	6 400
> 150 ≤ 300	3 310	5 400	6 000	9 600
> 300 ≤ 600	4 260	7 400	8 000	12 800
> 600 ≤ 1 000	6 600	11 940	12 000	19 200

**Table K.8 – Test voltages for testing long-term stress  
of solid insulation in MAINS CIRCUITS**

Voltage line-to-neutral a.c. r.m.s. or d.c.  V	Test voltage			
	1 min a.c. test V r.m.s.		1 min d.c. test voltage V d.c.	
	BASIC INSULATION and SUPPLEMENTARY INSULATION	REINFORCED INSULATION	BASIC INSULATION and SUPPLEMENTARY INSULATION	REINFORCED INSULATION
≤150	1 350	2 700	1 900	3 800
> 150 ≤ 300	1 500	3 000	2 100	4 200
> 300 ≤ 600	1 800	3 600	2 550	5 100
> 600 ≤ 1 000	2 200	4 400	3 100	6 200

Solid insulation shall also meet the following requirements, as applicable:

- 1) for solid insulation used as an ENCLOSURE or BARRIER, the requirements of Clause 8;
- 2) for moulded and potted parts, the requirements of K.1.3.2;
- 3) for inner layers of printed wiring boards, the requirements of K.1.3.3;
- 4) for thin-film insulation, the requirements of K.1.3.4;

*Conformity is checked as specified in K.1.3.2 to K.1.3.4, and in Clause 8, as applicable.*

#### **K.1.3.2 Moulded and potted parts**

For BASIC INSULATION, SUPPLEMENTARY INSULATION and REINFORCED INSULATION, conductors located between the same two layers moulded together (see Figure K.1, item L) shall be separated by at least the applicable minimum distance of Table K.9 after the moulding is completed.

*Conformity is checked by inspection and either by measurement of the separation or by inspection of the manufacturer's specifications.*

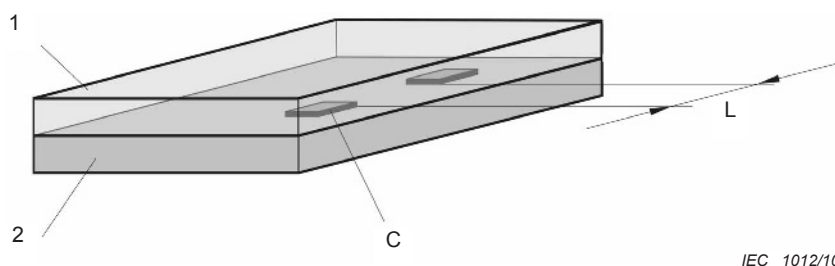

**Key**

- 1 Layer 1
- 2 Layer 2
- C Conductor
- L Distance between conductors

**Figure K.1 – Distance between conductors on an interface between two layers**

**K.1.3.3 Inner insulating layers of printed wiring boards**

For BASIC INSULATION, SUPPLEMENTARY INSULATION and REINFORCED INSULATION, conductors located between the same two layers (see Figure K.2, item L) shall be separated by at least the applicable minimum distance of Table K.9.

*Conformity is checked by inspection and either by measurement of the separation or by inspection of the manufacturer's specifications.*

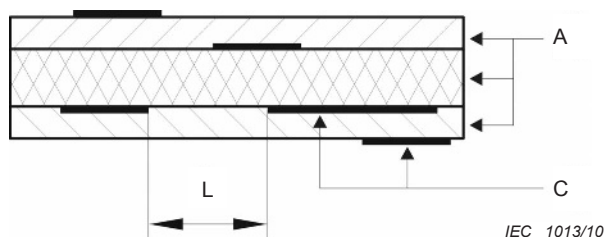

**Key**

- L Distance between adjacent conductors
- A Layers
- C Conductors

**Figure K.2 – Distance between adjacent conductors along an interface of an inner layer**

**Table K.9 – Minimum values for distance or thickness of solid insulation**

Line-to-neutral voltage	Minimum thickness a mm	Minimum distance L (see Figure K.2) a, b mm
V r.m.s. or d.c.	mm	mm
≤ 300	0,4	0,4
> 300 ≤ 600	0,6	0,6
> 600 ≤ 1 000	1,0	1,0

<sup>a</sup> These values are independent of the OVERVOLTAGE CATEGORY.  
<sup>b</sup> These values apply for BASIC INSULATION, SUPPLEMENTARY INSULATION and REINFORCED INSULATION.

REINFORCED INSULATION of inner insulating layers of printed wiring boards shall also have adequate electric strength through the respective layers. One of the following methods shall be used.

- a) the thickness through the insulation is at least the value of Table K.9.

*Conformity is checked by inspection and either by measurement of the separation or by inspection of the manufacturer's specifications.*

- b) the insulation is assembled from at least two separate layers of printed wiring board materials, each of which is RATED by the manufacturer of the material for an electric strength of at least the value of the test voltage of the applicable Table K.5, Table K.6 or Table K.7 for BASIC INSULATION.

*Conformity is checked by inspection of the manufacturer's specifications.*

- c) the insulation is assembled from at least two separate layers of printed wiring board materials, and the combination of layers is RATED by the manufacturer of the material for an electric strength of at least the value of the applicable Table K.5, Table K.6 or Table K.7 for REINFORCED INSULATION.

*Conformity is checked by inspection of the manufacturer's specifications.*

#### K.1.3.4 Thin-film insulation

For BASIC INSULATION, SUPPLEMENTARY INSULATION and REINFORCED INSULATION, conductors located between the same two layers (see Figure K.3, item L) shall be separated by at least the applicable CLEARANCE and CREEPAGE DISTANCE of K.1.2.

*Conformity is checked by inspection and either by measurement of the separation or by inspection of the manufacturer's specifications.*

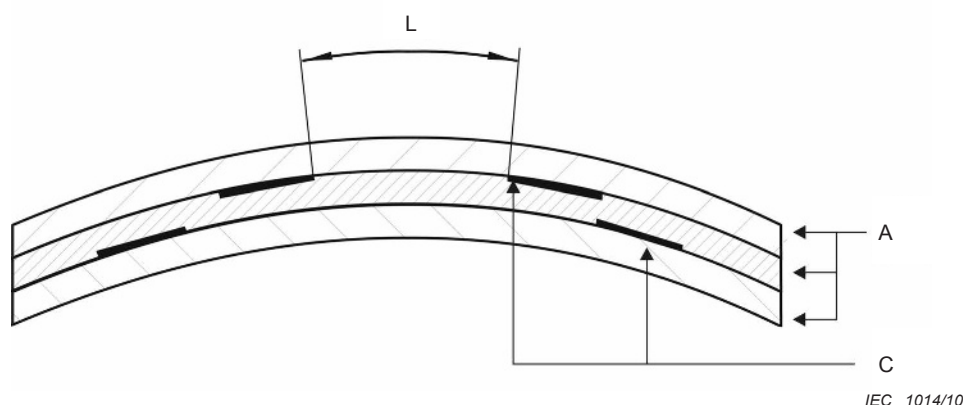

#### Key

- L Distance between adjacent conductors
- A Layers of thin-film material such as tape and polyester film
- C Conductors

NOTE There may be air present between the layers

**Figure K.3 – Distance between adjacent conductors located between the same two layers**

REINFORCED INSULATION through the layers of thin-film insulation shall also have adequate electric strength. One of the following methods shall be used.



- a) The thickness through the insulation is at least the value of Table K.9.

*Conformity is checked by inspection and either by measurement of the separation or by inspection of the manufacturer's specifications.*

- b) The insulation consists of at least two separate layers of thin-film materials, each of which is RATED by the manufacturer of the material for an electric strength of at least the value of the test voltages from Table K.5, Table K.6 or Table K.7 as applicable for BASIC INSULATION.

*Conformity is checked by inspection of the manufacturer's specifications.*

- c) The insulation consists of at least three separate layers of thin-film materials, any two of which have been tested to exhibit adequate electric strength.

*Conformity is checked by the a.c. test of 6.8.3.1 with a duration of at least 1 min or for MAINS CIRCUITS stressed only by d.c. the 1 min d.c. test of 6.8.3.2 applied to two of the three layers using the applicable voltage for REINFORCED INSULATION of Table K.5, Table K.6 or Table K.7.*

NOTE—For the purposes of this test a special sample may be assembled with only two layers of the material.

## **K.2 Insulation in secondary circuits**

### **K.2.1 General**

In this Technical Specification, secondary circuits are circuits where separation from MAINS CIRCUITS is achieved by a transformer in which the primary windings are separated from the secondary windings by REINFORCED INSULATION, DOUBLE INSULATION, or a screen connected to the PROTECTIVE CONDUCTOR TERMINAL.

NOTE These circuits are assumed to be subjected to lower TRANSIENT OVERVOLTAGE levels than the MAINS CIRCUIT.

### **K.2.2 CLEARANCES**

CLEARANCES for secondary circuits shall:

- a) for BASIC INSULATION or SUPPLEMENTARY INSULATION, meet the applicable values of Tables K.10, K.11 and K.12, or for REINFORCED INSULATION meet twice that value; or
- b) pass the voltage test of 6.8 using the applicable value of Table K.10, Table K.11 or Table K.12.

For the application of Tables K.10 to K.12, the following applies:

- 1) values for test voltages for REINFORCED INSULATION are 1,6 times the values for BASIC INSULATION;
- 2) if the equipment is RATED to operate at an altitude greater than 2 000 m, the values for CLEARANCES are multiplied by the applicable factor of Table K.1;
- 3) minimum CLEARANCE is 0,2 mm for POLLUTION DEGREE 2 and 0,8 mm for POLLUTION DEGREE 3.

*Conformity is checked by inspection and measurement and for b) by the a.c. test of 6.8.3.1 with a duration of at least 5 s, or by the 1 min d.c. test of 6.8.3.2, using the applicable test voltage from Tables K.10 to K.12. The value of the d.c. test voltage is  $\sqrt{2}$  times the a.c. r.m.s. test voltage.*

**Table K.10 – CLEARANCES and test voltages for secondary circuits derived from MAINS CIRCUITS of OVERVOLTAGE CATEGORY II above 300 V**

Secondary WORKING VOLTAGE		MAINS voltage > 300 ≤ 600 V r.m.s.		MAINS voltage > 600 ≤ 1 000 V r.m.s.	
a.c. r.m.s.	d.c. or a.c. peak	CLEARANCE	Test voltage	CLEARANCE	Test voltage
V	V	mm	V r.m.s.	mm	V r.m.s.
16	22,6	1,5	1 390	2,9	1 590
33	46,7	1,5	1 390	3,0	2 210
50	70	1,5	1 390	3,0	2 210
100	140	1,6	1 450	3,1	2 260
150	210	1,6	1 450	3,2	2 300
300	420	1,8	1 540	3,4	2 400
600	840	2,4	1 620	3,9	2 630
1 000	1 400	3,5	2 450	5,0	3 110
1 250	1 750	4,2	2 770	5,8	3 430
1 600	2 240	5,2	3 190	6,9	3 850
2 000	2 800	6,5	3 700	8,2	4 330
2 500	3 500	8,1	4 300	9,8	4 920
3 200	4 480	10	4 950	12	5 780
4 000	5 600	12	5 780	15	7 000
5 000	7 000	16	7 400	18	8 200
6 300	8 820	20	8 980	22	9 700
8 000	11 200	26	11 200	28	11 900
10 000	14 000	33	13 800	35	14 500
12 500	17 500	42	16 900	44	17 600
16 000	22 400	55	21 200	57	21 900
20 000	28 000	71	26 300	73	27 000
25 000	35 000	91	32 600	93	33 200
32 000	44 800	120	41 600	122	42 200
40 000	56 000	154	52 200	157	53 100
50 000	70 000	199	66 100	202	67 000
63 000	88 200	261	85 300	262	85 600

Linear interpolation is allowed.

**Table K.11 – CLEARANCES and test voltages for secondary circuits  
 derived from MAINS CIRCUITS of OVERVOLTAGE CATEGORY III**

Secondary WORKING VOLTAGE		MAINS voltage $\leq 150$ V a.c. r.m.s.		MAINS voltage $>150 \leq 300$ V a.c. r.m.s.		MAINS voltage $>300 \leq 600$ V a.c. r.m.s.		MAINS voltage $>600 \leq 1\ 000$ V a.c. r.m.s.	
a.c. r.m.s. V	d.c. or a.c. peak V	CLEARANCE mm	Test voltage V a.c. r.m.s.	CLEARANCE mm	Test voltage V a.c. r.m.s.	CLEARANCE mm	Test voltage V a.c. r.m.s.	CLEARANCE mm	Test voltage V a.c. r.m.s.
16	22,6	0,48	1 100	1,5	1 800	2,9	2 820	5,4	4 240
33	47,3	0,50	1 100	1,5	1 800	3,0	2 900	5,4	4 240
50	70	0,53	1 120	1,5	1 800	3,0	2 900	5,5	4 300
100	140	0,61	1 170	1,6	1 880	3,1	2 960	5,6	4 360
150	210	0,69	1 200	1,6	1 880	3,2	3 020	5,7	4 420
300	420	0,94	1 360	1,8	2 040	3,4	3 140	6,0	4 600
600	840	1,6	1 880	2,4	2 440	3,9	3 440	6,6	4 860
1 000	1 400	2,5	2 500	3,5	3 200	5,0	4 000	7,4	5 240
1 250	1 750	3,2	3 020	4,2	3 620	5,8	4 480	8,1	5 560
1 600	2 240	4,1	3 560	5,2	4 120	6,9	5 040	9,3	6 120
2 000	2 800	5,3	4 180	6,5	4 800	8,2	5 620	11	7 000
2 500	3 500	6,9	5 040	8,1	5 560	9,8	6 320	12	7 500
3 200	4 480	9,2	6 080	10	6 400	12	7 500	15	9 100
4 000	5 600	12	7 500	12	7 500	15	9 100	17	10 100
5 000	7 000	15	9 100	16	9 600	18	10 600	20	11 600
6 300	8 820	19	11 200	20	11 600	22	12 600	25	14 100
8 000	11 200	25	14 100	26	14 600	28	15 500	31	16 900
10 000	14 000	32	17 400	33	17 800	35	18 700	38	20 000
12 500	17 500	41	21 500	42	21 900	44	22 800	47	24 200
16 000	22 400	54	27 200	55	27 600	57	28 400	60	29 700
20 000	28 000	69	33 500	71	34 300	73	35 200	76	36 400
25 000	35 000	89	41 600	91	42 400	93	43 200	96	44 400
32 000	44 800	118	53 000	120	53 700	122	54 500	125	55 600
40 000	56 000	153	66 100	154	66 500	157	67 600	160	68 700
50 000	70 000	198	82 400	199	82 700	202	83 800	205	84 900
63 000	88 200	260	104 000	261	104 400	262	104 700	265	105 700

Linear interpolation is allowed.

**Table K.12 – CLEARANCES and test voltages for secondary circuits derived from MAINS CIRCUITS of OVERVOLTAGE CATEGORY IV**

Secondary WORKING VOLTAGE		MAINS voltage $\leq 150$ V a.c. r.m.s.		MAINS voltage $> 150 \leq 300$ V a.c. r.m.s.		MAINS voltage $> 300 \leq 600$ V a.c. r.m.s.		MAINS voltage $> 600 \leq 1\,000$ V a.c. r.m.s.	
a.c. r.m.s. V	d.c. or a.c. peak V	CLEARANCE mm	Test voltage V a.c. r.m.s.	CLEARANCE mm	Test voltage V a.c. r.m.s.	CLEARANCE mm	Test voltage V a.c. r.m.s.	CLEARANCE mm	Test voltage V a.c. r.m.s.
16	22,6	1,5	1 800	2,9	2 820	5,4	4 240	8,3	5 680
33	46,7	1,5	1 800	3,0	2 900	5,4	4 240	8,3	5 680
50	70	1,5	1 800	3,0	2 900	5,5	4 300	8,4	5 740
100	140	1,6	1 880	3,1	2 960	5,6	4 360	8,5	5 800
150	210	1,6	1 880	3,2	3 020	5,7	4 420	8,6	5 860
300	420	1,8	2 040	3,4	3 140	6,0	4 600	8,9	5 960
600	840	2,4	2 440	3,9	3 440	6,6	4 860	9,6	6 240
1 000	1 400	3,5	3 200	5,0	4 000	7,4	5 240	10	6 400
1 250	1 750	4,2	3 620	5,8	4 480	8,1	5 560	11	7 000
1 600	2 240	5,2	4 120	6,9	5 040	9,3	6 120	12	7 500
2 000	2 800	6,5	4 800	8,2	5 620	11	7 000	13	8 100
2 500	3 500	8,1	5 560	9,8	6 320	12	7 500	15	9 100
3 200	4 480	10	6 400	12	7 500	15	9 100	17	10 100
4 000	5 600	12	7 500	15	9 100	17	10 100	19	11 200
5 000	7 000	16	9 600	18	10 600	20	11 600	23	13 100
6 300	8 820	20	11 600	22	12 600	25	14 100	27	15 100
8 000	11 200	26	14 600	28	15 500	31	16 900	33	17 800
10 000	14 000	33	17 800	35	18 700	38	20 000	40	21 000
12 500	17 500	42	21 900	44	22 800	47	24 200	50	25 500
16 000	22 400	55	27 600	57	28 400	60	29 700	63	31 000
20 000	28 000	71	34 300	73	35 200	76	36 400	79	37 600
25 000	35 000	91	42 400	93	43 200	96	44 400	99	45 400
32 000	44 800	120	53 700	122	54 500	125	55 600	129	57 100
40 000	56 000	154	66 500	157	67 600	160	68 700	164	70 100
50 000	70 000	199	82 700	202	83 800	205	84 900	209	86 300
63 000	88 200	261	104 400	262	104 700	265	105 700	268	106 800

Linear interpolation is allowed.

### K.2.3 CREEPAGE DISTANCES

CREEPAGE DISTANCES for BASIC INSULATION or SUPPLEMENTARY INSULATION for secondary circuits shall meet the applicable values of Table K.13, based on the WORKING VOLTAGE which stresses the insulation. Values for REINFORCED INSULATION are twice the values for BASIC INSULATION.

*Conformity is checked by inspection and measurement.*

Coatings that meet the requirements of Annex H when applied to the outer surfaces of printed wiring boards reduce the POLLUTION DEGREE of the coated area to POLLUTION DEGREE 1.

*Conformity is checked by inspection and as specified in Annex H.*

**Table K.13 – CREEPAGE DISTANCES for secondary circuits**

Secondary WORKING VOLTAGE a.c. r.m.s. or d.c.	Printed wiring board material		Other insulating material						
	POLLUTION DEGREE 1	POLLUTION DEGREE 2	POLLUTION DEGREE 1	POLLUTION DEGREE 2			POLLUTION DEGREE 3		
	All material groups	Material group I, II or IIIa	All material groups	Material group I	Material group II	Material group III	Material group I	Material group II	Material group III <sup>b</sup>
V	mm	mm	mm	mm	mm	mm	mm	mm	mm
10	0,025	0,04	0,08	0,40	0,40	0,40	1,00	1,00	1,00
12,5	0,025	0,04	0,09	0,42	0,42	0,42	1,05	1,05	1,05
16	0,025	0,04	0,10	0,45	0,45	0,45	1,10	1,10	1,10
20	0,025	0,04	0,11	0,48	0,48	0,48	1,20	1,20	1,20
25	0,025	0,04	0,125	0,50	0,50	0,50	1,25	1,25	1,25
32	0,025	0,04	0,14	0,53	0,53	0,53	1,3	1,3	1,3
40	0,025	0,04	0,16	0,56	0,80	1,10	1,4	1,6	1,8
50	0,025	0,04	0,18	0,60	0,85	1,20	1,5	1,7	1,9
63	0,040	0,063	0,20	0,63	0,90	1,25	1,6	1,8	2,0
80	0,063	0,10	0,22	0,67	0,95	1,3	1,7	1,9	2,1
100	0,10	0,16	0,25	0,71	1,00	1,4	1,8	2,0	2,2
125	0,16	0,25	0,28	0,75	1,05	1,5	1,9	2,1	2,4
160	0,25	0,40	0,32	0,80	1,1	1,6	2,0	2,2	2,5
200	0,40	0,63	0,42	1,00	1,4	2,0	2,5	2,8	3,2
250	0,56	1,0	0,56	1,25	1,8	2,5	3,2	3,6	4,0
320	0,75	1,6	0,75	1,60	2,2	3,2	4,0	4,5	5,0
400	1,0	2,0	1,0	2,0	2,8	4,0	5,0	5,6	6,3
500	1,3	2,5	1,3	2,5	3,6	5,0	6,3	7,1	8,0
630	1,8	3,2	1,8	3,2	4,5	6,3	8,0	9,0	10,0
800	2,4	4,0	2,4	4,0	5,6	8,0	10,0	11	12,5
1 000	3,2 <sup>a</sup>	5,0 <sup>a</sup>	3,2	5,0	7,1	10,0	12,5	14	16
1 250			4,2	6,3	9,0	12,5	16	18	20
1 600			5,6	8,0	11	16	20	22	25
2 000			7,5	10,0	14	20	25	28	32
2 500			10,0	12,5	18	25	32	36	40
3 200			12,5	16	22	32	40	45	50
4 000			16	20	28	40	50	56	63
5 000			20	25	36	50	63	71	80
6 300			25	32	45	63	80	90	100
8 000			32	40	56	80	100	110	125
10 000			40	50	71	100	125	140	160
12 500			50	63	90	125			
16 000			63	80	110	160			
20 000			80	100	140	200			
25 000			100	125	180	250			
32 000			125	160	220	320			
40 000			160	200	280	400			
50 000			200	250	360	500			
63 000			250	320	450	600			

Linear interpolation is allowed.

<sup>a</sup> For voltages above 1 000 V, CREEPAGE DISTANCES on printed wiring board material are the same as for other insulators of the same material group.

<sup>b</sup> Material group IIIb is not recommended for application in pollution degree 3 above 630 V.

## **K.2.4 Solid insulation**

### **K.2.4.1 General**

Solid insulation in secondary circuits shall withstand the electrical and mechanical stresses that may occur in NORMAL USE, in all RATED environmental conditions (see 1.4), during the intended life of the equipment.

**NOTE**—The manufacturer should take the expected life of the equipment into account when selecting insulating materials.

*Conformity is checked by both of the following tests:*

- a) by the voltage test of 6.8.3.1 for 5 s using the applicable test voltage of Table K.10, Table K.11 or Table K.12 for BASIC INSULATION and SUPPLEMENTARY INSULATION. For REINFORCED INSULATION, the values are multiplied by 1,6;*
- b) additionally, if the WORKING VOLTAGE exceeds 300 V, by the voltage test of 6.8.3.1 for 1 min, with a test voltage of 1,5 times the WORKING VOLTAGE for BASIC INSULATION and SUPPLEMENTARY INSULATION and twice the WORKING VOLTAGE for REINFORCED INSULATION.*

Solid insulation shall also meet the following requirements, as applicable:

- 1) for solid insulation used as an ENCLOSURE or BARRIER, the requirements of Clause 8;
- 2) for moulded and potted parts, the requirements of K.2.4.2;
- 3) for inner insulating layers of printed wiring boards, the requirements of K.2.4.3;
- 4) for thin-film insulation, the requirements of K.2.4.4.

*Conformity is checked as specified in K.2.4.2 to K.2.4.4 and Clause 8, as applicable.*

### **K.2.4.2 Moulded and potted parts**

For BASIC INSULATION, SUPPLEMENTARY INSULATION and REINFORCED INSULATION, conductors located between the same two layers shall be separated by the applicable minimum distance of Table K.14 (see Figure K.1, item L).

*Conformity is checked by inspection and either by measurement of the separation or by inspection of the manufacturer's specifications.*

**Table K.14 – Minimum values for distance or thickness  
 (see K.2.4.2 to K.2.4.4)**

Peak value of the a.c. or d.c WORKING VOLTAGE or recurring peak voltage kV	Minimum value mm	Peak value of the a.c. or d.c WORKING VOLTAGE or recurring peak voltage kV	Minimum value mm
> 0,046 7 ≤ 0,33	0,05	> 8,0 ≤ 10	3,5
> 0,33 ≤ 0,8	0,1	> 10 ≤ 12	4,5
> 0,8 ≤ 1,0	0,15	> 12 ≤ 15	5,5
> 1,0 ≤ 1,2	0,2	> 15 ≤ 20	8
> 1,2 ≤ 1,5	0,3	> 20 ≤ 25	10
> 1,5 ≤ 2,0	0,45	> 25 ≤ 30	12,5
> 2,0 ≤ 2,5	0,6	> 30 ≤ 40	17
> 2,5 ≤ 3,0	0,8	> 40 ≤ 50	22
> 3,0 ≤ 4,0	1,2	> 50 ≤ 60	27
> 4,0 ≤ 5,0	1,5	> 60 ≤ 80	35
> 5,0 ≤ 6,0	2	> 80 ≤ 100	45
> 6,0 ≤ 8,0	3		

### K.2.4.3 Inner insulating layers of printed wiring boards

For BASIC INSULATION, SUPPLEMENTARY INSULATION and REINFORCED INSULATION conductors located between the same two layers shall be separated by the applicable minimum distance of Table K.14 (see Figure K.2, item L).

*Conformity is checked by inspection and either by measurement of the separation or by inspection of the manufacturer's specifications.*

REINFORCED INSULATION of inner insulating layers of printed wiring boards shall also have adequate electric strength through the respective layers. One of the following methods shall be used:

- a) the thickness of the insulation is at least the applicable minimum distance of Table K.14.

*Conformity is checked by inspection and either by measurement of the separation or by inspection of the manufacturer's specifications.*

- b) the insulation is assembled from at least two separate layers of printed wiring board materials, each of which is RATED by the manufacturer of the material for an electric strength at least the value of the test voltage of the applicable Table K.10 to K.12 for BASIC INSULATION.

*Conformity is checked by inspection of the manufacturer's specifications.*

- c) the insulation is assembled from at least two separate layers of printed wiring board materials, and the combination of layers is RATED by the manufacturer of the material for an electric strength at least the value of the test voltage of the applicable Table K.10, Table K.11 or Table K.12 multiplied by 1,6 for REINFORCED INSULATION.

*Conformity is checked by inspection of the manufacturer's specifications.*

#### K.2.4.4 Thin-film insulation

For BASIC INSULATION, SUPPLEMENTARY INSULATION and REINFORCED INSULATION conductors located between the same two layers (see Figure K.3, item L) shall be separated by at least the applicable CLEARANCE and CREEPAGE DISTANCE of K.2.2 and K.2.3.

*Conformity is checked by inspection and either by measurement of the separation or by inspection of the manufacturer's specifications.*

REINFORCED INSULATION through the layers of thin-film insulation shall also have adequate electric strength. One of the following methods shall be used:

- a) the thickness through the insulation is at least the applicable value of Table K.14;  
*Conformity is checked by inspection and either by measurement of the separation or by inspection of the manufacturer's specifications.*
- b) the insulation consists of at least two separate layers of thin-film materials, each of which is RATED by the manufacturer of the material for an electric strength at least the value of the test voltage of the applicable Table K.10, Table K.11 or Table K.12 for BASIC INSULATION;  
*Conformity is checked by inspection of the manufacturer's specifications.*
- c) the insulation consists of at least three separate layers of thin-film materials, any two of which have been tested to exhibit adequate electric strength.  
*Conformity is checked by the a.c. test of 6.8.3.1 with a duration of at least 1 min, or for MAINS CIRCUITS stressed only by d.c., the 1 min d.c. test of 6.8.3.2, using the applicable voltages from Table K.10, Table K.11 or Table K.12 multiplied by 1,6, applied to two of the three layers.*

*For the purposes of the test for option c), a special sample may be assembled with only two layers of the material.*

### K.3 Insulation in circuits not addressed in 6.7, K.1 or K.2

#### K.3.1 General

These circuits have one or more of the following characteristics:

- a) the maximum possible TRANSIENT OVERVOLTAGE is limited by the supply source or within the equipment (see K.4.) to a known level below the level assumed for the MAINS CIRCUIT;
- b) the maximum possible TRANSIENT OVERVOLTAGE is above the level assumed for the MAINS CIRCUIT;
- c) the WORKING VOLTAGE is the sum of voltages from more than one circuit, or is a mixed voltage;
- d) the WORKING VOLTAGE includes a recurring peak voltage that may include a periodic non-sinusoidal waveform or a non-periodic waveform that occurs with some regularity;
- e) the WORKING VOLTAGE has a frequency above 30 kHz.

In cases a) to c), CLEARANCES for BASIC INSULATION and SUPPLEMENTARY INSULATION are determined according to K.3.2.

In cases d) and e) CLEARANCES are determined according to K.3.3.

In all cases K.3.4 addresses CREEPAGE DISTANCE and K.3.5 solid insulation

NOTE Requirements for measuring circuits are given in IEC 61010-2-030.



### **K.3.2 CLEARANCE calculation**

CLEARANCES for BASIC INSULATION and SUPPLEMENTARY INSULATION are determined from the following formula:

$$\text{CLEARANCE} = D_1 + F \times (D_2 - D_1)$$

where

$F$  is a factor, determined from one of the equations:

$$F = (1,25 \times U_w/U_m) - 0,25 \quad \text{if } U_w/U_m > 0,2$$

$$F = 0 \quad \text{if } U_w/U_m \leq 0,2$$

where

$$U_m = U_w + U_t;$$

$U_w$  = the maximum peak value of the WORKING VOLTAGE;

$U_t$  = the maximum additional TRANSIENT OVERVOLTAGE

$D_1$  and  $D_2$  are values taken from Table K.15 for  $U_m$

where

$D_1$  represents the CLEARANCE that would be applicable to a TRANSIENT OVERVOLTAGE with the shape of a  $1,2 \times 50 \mu\text{s}$  impulse.

$D_2$  represents the CLEARANCE that would be applicable to the peak WORKING VOLTAGE without any TRANSIENT OVERVOLTAGE.

CLEARANCES for REINFORCED INSULATION are twice the values for BASIC INSULATION.

If the equipment is RATED to operate at an altitude greater than 2 000 m, the CLEARANCES shall be multiplied by the applicable factor of Table K.1.

Minimum CLEARANCE, for BASIC INSULATION, SUPPLEMENTARY INSULATION and REINFORCED INSULATION, is 0,2 mm for POLLUTION DEGREE 2 and 0,8 mm for POLLUTION DEGREE 3.

*Conformity is checked by inspection and measurement or by the a.c. test of 6.8.3.1 with a duration of at least 5 s or the impulse voltage test of 6.8.3.3, using the applicable voltage from Table K.16 for the required CLEARANCE.*

**Table K.15 – CLEARANCE values for the calculation of K.3.2**

Maximum voltage $U_m$	CLEARANCE		Maximum voltage $U_m$	CLEARANCE	
	$D_1$	$D_2$		$D_1$	$D_2$
V	mm	mm	V	mm	mm
14,1 to 266	0,010	0,010	4 000	2,93	6,05
283	0,010	0,013	4 530	3,53	7,29
330	0,010	0,020	5 660	4,92	10,1
354	0,013	0,025	6 000	5,37	10,8
453	0,027	0,052	7 070	6,86	13,1
500	0,036	0,071	8 000	8,25	15,2
566	0,052	0,10	8 910	9,69	17,2
707	0,081	0,20	11 300	12,9	22,8
800	0,099	0,29	14 100	16,7	29,5
891	0,12	0,41	17 700	21,8	38,5
1 130	0,19	0,83	22 600	29,0	51,2
1 410	0,38	1,27	28 300	37,8	66,7
1 500	0,45	1,40	35 400	49,1	86,7
1 770	0,75	1,79	45 300	65,5	116
2 260	1,25	2,58	56 600	85,0	150
2 500	1,45	3,00	70 700	110	195
2 830	1,74	3,61	89 100	145	255
3 540	2,44	5,04	100 000	165	290

Linear interpolation is allowed.

**Table K.16 – Test voltages based on CLEARANCES**

Required CLEARANCE	Test voltage	
	Impulse 1,2/50 µs	a.c. r.m.s. 50/60 Hz
	V peak	V r.m.s.
mm		
0,010	330	230
0,025	440	310
0,040	520	370
0,063	600	420
0,1	810	500
0,2	1 150	620
0,3	1 310	710
0,5	1 550	840
1,0	1 950	1 060
1,5	2 560	1 390
2,0	3 090	1 680
2,5	3 600	1 960
3,0	4 070	2 210
4,0	4 930	2 680
4,5	5 330	2 900
5,0	5 720	3 110
6,0	6 460	3 510
8,0	7 840	4 260
10,0	9 100	4 950
12,0	10 600	5 780
15,0	12 900	7 000
20	16 400	8 980
25	19 900	10 800
30	23 300	12 700
40	29 800	16 200
50	36 000	19 600
60	42 000	22 800
80	53 700	29 200
100	65 000	35 400

Linear interpolation is allowed.

NOTE Two examples of calculations follow:

EXAMPLE 1:

CLEARANCE for REINFORCED INSULATION for a WORKING VOLTAGE with peak value of 3 500 V and an additional transient voltage of 4 500 V (this can be expected within an electronic switching-circuit):

Maximum voltage  $U_m$  
$$U_m = U_w + U_t = (3\,500 + 4\,500) \text{ V} = 8\,000 \text{ V}$$

$$U_w / U_m = 3\,500 / 8\,000 = 0,44 > 0,2$$

$$\text{thus } F = (1,25 \times U_w / U_m) - 0,25 = (1,25 \times 3\,500 / 8\,000) - 0,25 = 0,297$$

Values derived from Table K.15 at 8 000 V:

$$D_1 = 8,25 \text{ mm}, D_2 = 15,2 \text{ mm}$$

$$\text{CLEARANCE} = D_1 + F \times (D_2 - D_1) = 8,25 + 0,297 \times (15,2 - 8,25) = 8,25 + 2,06 = 10,3 \text{ mm}$$

For REINFORCED INSULATION the value is doubled. CLEARANCE = 20,6 mm.

EXAMPLE 2:

CLEARANCE for BASIC INSULATION for a circuit driven from a MAINS transformer connected to an outlet of the distribution system with a MAINS voltage of 230 V and OVERVOLTAGE CATEGORY II. The circuit includes transient overvoltage limiting devices (see 14.8 and K.3.4) which limit the maximum voltage (including transients) in the circuit to 1 000 V.

The peak value ( $U_w$ ) of the voltage in the circuit is 150 V.

The maximum value of the voltage  $U_m$  is therefore 1 000 V.

$$U_m = 1\,000 \text{ V}$$

$$U_w / U_m = 150 / 1\,000 = 0,15 < 0,2, \text{ thus } F = 0$$

CLEARANCE  $D_1 = 0,15 \text{ mm}$  interpolated from Table K.15

The CLEARANCE is then corrected for altitude and checked against POLLUTION DEGREE minimum CLEARANCES.

**K.3.3 CLEARANCES in circuits having recurring peak voltages, or having WORKING VOLTAGES with frequencies above 30 kHz**

CLEARANCES for BASIC INSULATION and SUPPLEMENTARY INSULATION for circuits having recurring peak voltages but not subjected to frequencies above 30 kHz shall meet the values of the second column of Table K.17, using the recurring peak voltage as the index. (See Figure K.4 for an example of a recurring peak voltage.)

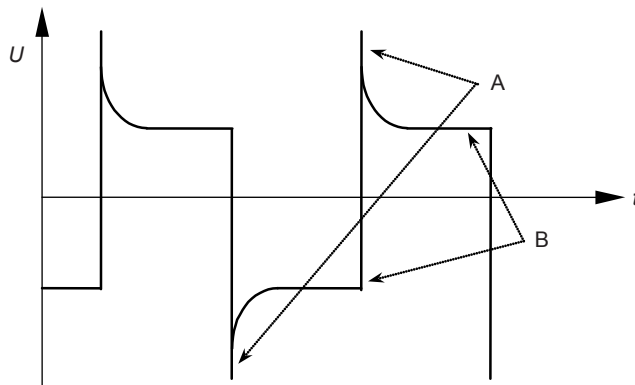

IEC 1206/02

**Key**

- A Peak value of recurring voltage
- B WORKING VOLTAGE value

**Figure K.4 – Example of recurring peak voltage**

CLEARANCES for BASIC INSULATION and SUPPLEMENTARY INSULATION for circuits that are subjected to frequencies above 30 kHz shall meet the values of the third column of Table K.17, using the peak value of the WORKING VOLTAGE as the index.

CLEARANCES for BASIC INSULATION and SUPPLEMENTARY INSULATION for circuits that may be subjected to both recurring peak voltages and to frequencies above 30 kHz shall meet the higher of these requirements.

CLEARANCES for REINFORCED INSULATION are twice the values for BASIC INSULATION.

If the equipment is RATED to operate at an altitude greater than 2 000 m, the CLEARANCES are multiplied by the applicable factor of Table K.1.

The minimum CLEARANCE, for BASIC INSULATION, SUPPLEMENTARY INSULATION and REINFORCED INSULATION, is 0,2 mm for POLLUTION DEGREE 2 and 0,8 mm for POLLUTION DEGREE 3.

*Conformity is checked by inspection and measurement.*

**Table K.17 – CLEARANCES for BASIC INSULATION in circuits having recurring peak voltages or WORKING VOLTAGES with frequencies above 30 kHz**

Voltage peak value	CLEARANCES	
	Frequencies up to 30 kHz	Frequencies above 30 kHz
V	mm	mm
0 to 330	0,01	0,02
400	0,02	0,04
500	0,04	0,07
600	0,06	0,11
800	0,13	0,26
1 000	0,26	0,48
1 200	0,42	0,76
1 500	0,76	1,1
2 000	1,27	1,8
2 500	1,8	2,6
3 000	2,4	3,5
4 000	3,8	5,7
5 000	5,7	8
6 000	7,9	10
8 000	11	15
10 000	15,2	20
12 000	19	25
15 000	25	32
20 000	34	44
25 000	44	58
30 000	55	72
40 000	77	100
50 000	100	
Linear interpolation is allowed.		

#### **K.3.4 CREEPAGE DISTANCES**

The requirements of K.2.3 apply.

*Conformity is checked as specified in K.2.3.*

### **K.3.5 Solid insulation**

The requirements of K.2.4 apply except that in K.2.4.1 a), K.2.4.3 b) and c), and K.2.4.4 b) and c) the values of Table K.16 are used in place of the applicable values of Table K.10, Table K.11, or Table K.12.

To determine the required test voltage from Table K.16, the following procedure shall be applied:

- a) Calculation of the theoretically required CLEARANCE according to K.3.2 considering the requirements of K.3.3. Minimum CLEARANCES for POLLUTION DEGREES 2 and 3 do not apply.
- b) Application of the resulting theoretically required CLEARANCE value of Table K.16 to determine the required test voltage.

*Conformity is checked as specified in K.2.4, using the test voltage determined above in place of the test voltage from Table K.10, Table K.11, or Table K.12.*

### **K.4 Reduction of TRANSIENT OVERVOLTAGES by the use of overvoltage limiting devices**

TRANSIENT OVERVOLTAGES in a circuit may be limited by combinations of circuits or components. Components suitable for this purpose include varistors and gas-filled surge arrestors.

If the overvoltage limiting device or circuit is intended to reduce TRANSIENT OVERVOLTAGES so that the circuit following it may have reduced CLEARANCES, a RISK assessment (see Clause 17) shall be performed, taking into account both of the following aspects:

- a) the circuit shall reduce TRANSIENT OVERVOLTAGES to the lower level even under SINGLE FAULT CONDITIONS;
- b) the circuit shall operate as intended even after withstanding repeated TRANSIENT OVERVOLTAGES.

*Conformity is checked by evaluation of the RISK assessment documentation to ensure that the RISKS have been eliminated or that only TOLERABLE RISKS remain.*

**Annex L**  
(informative)

**Index of defined terms**

<b>Term</b>	<b>Definition</b>
ACCESSIBLE (of a part) .....	3.5.1
BASIC INSULATION .....	3.6.1
<u>CHILD .....</u>	<u>3.5.20</u>
CLEARANCE .....	3.6.11
CREEPAGE DISTANCE .....	3.6.12
DIRECT PLUG-IN EQUIPMENT .....	3.1.6
DOUBLE INSULATION .....	3.6.3
ENCLOSURE .....	3.2.4
FIXED EQUIPMENT .....	3.1.1
FUNCTIONAL EARTH TERMINAL .....	3.2.2
HAND-HELD EQUIPMENT .....	3.1.4
HAZARD .....	3.5.2
HAZARDOUS LIVE.....	3.5.3
MAINS .....	3.5.4
MAINS CIRCUIT .....	3.5.5
NORMAL CONDITION.....	3.5.9
NORMAL USE.....	3.5.8
OPERATOR .....	3.5.11
OVERVOLTAGE CATEGORY .....	3.5.17
PERMANENTLY CONNECTED EQUIPMENT.....	3.1.2
POLLUTION .....	3.6.5
POLLUTION DEGREE.....	3.6.6
POLLUTION DEGREE 1 .....	3.6.7
POLLUTION DEGREE 2 .....	3.6.8
POLLUTION DEGREE 3 .....	3.6.9
POLLUTION DEGREE 4 .....	3.6.10
PORTABLE EQUIPMENT .....	3.1.3
PROTECTIVE BARRIER .....	3.2.5
PROTECTIVE BONDING .....	3.5.7
PROTECTIVE CONDUCTOR TERMINAL.....	3.2.3
PROTECTIVE IMPEDANCE .....	3.5.6
RATED (value).....	3.3.1
RATING .....	3.3.2
REASONABLY FORESEEABLE MISUSE.....	3.5.14
REINFORCED INSULATION .....	3.6.4
RESPONSIBLE BODY.....	3.5.12
RISK .....	3.5.15
ROUTINE TEST .....	3.4.2



SINGLE FAULT CONDITION.....	3.5.10
<u>STUDENT OPERATOR .....</u>	<u>3.5.21</u>
SUPPLEMENTARY INSULATION.....	3.6.2
TEMPORARY OVERVOLTAGE.....	3.5.19
TERMINAL.....	3.2.1
TOLERABLE RISK .....	3.5.16
TOOL .....	3.1.5
TRANSIENT OVERVOLTAGE .....	3.5.18
TYPE TEST.....	3.4.1
WET LOCATION.....	3.5.13
WORKING VOLTAGE.....	3.3.3

## Bibliography

IEC 60050 (all parts), *International Electrotechnical Vocabulary* (available at <http://www.electropedia.org>)

~~IEC 60050-151, International Electrotechnical Vocabulary – Part 151: Electrical and magnetic devices~~

~~IEC 60050-195, International Electrotechnical Vocabulary – Part 195: Earthing and protection against electric shock~~

~~IEC 60050-604, International Electrotechnical Vocabulary – Chapter 604: Generation, transmission and distribution of electricity – Operation~~

~~IEC 60050-826, International Electrotechnical Vocabulary – Part 826: Electrical installations~~

IEC 60079 (all parts), *Explosive atmospheres*

IEC 60085, *Electrical insulation – Thermal evaluation and designation*

IEC 60112, *Method for the determination of the proof and the comparative tracking indices of solid insulating materials*

IEC 60127 (all parts), *Miniature fuses*

IEC 60204 (all parts), *Safety of machinery – Electrical equipment of machines*

~~IEC 60332-1 (all parts), Tests on electric and optical fibre cables under fire conditions~~

~~IEC 60332-2 (all parts), Tests on electric and optical fibre cables under fire conditions~~

~~IEC 60335 (all parts), Household and similar electrical appliances – Safety~~

~~IEC 60364 (all parts), Low voltage electrical installations~~

IEC 60364-4-44:2007, Low-voltage electrical installations – Part 4-44: Protection for safety – Protection against voltage disturbances and electromagnetic disturbances

~~IEC 60439 (all parts), Low-voltage switchgear and controlgear assemblies~~

IEC 60445, *Basic and safety principles for man-machine interface, marking and identification – Identification of equipment terminals, conductor terminations and conductors*

IEC 60447, *Basic and safety principles for man-machine-interface, marking and identification – Actuating principles*

IEC 60601-1, *Medical electrical equipment – Part 1: General requirements for basic safety and essential performance*

IEC 60664-1, *Insulation coordination for equipment within low-voltage systems – Part 1: Principles, requirements and tests*

IEC 60695-10-2, *Fire hazard testing – Part 10-2: Abnormal heat – Ball pressure test*

IEC 60950 (all parts), *Information technology equipment – Safety*

IEC 60950-1, *Information technology equipment – Safety – Part 1: General requirements*

IEC 60990, *Methods of measurement of touch current and protective conductor current*

IEC 61010-031, Safety requirements for electrical equipment for measurement, control and laboratory use – Part 031: Safety requirements for hand-held probe assemblies for electrical measurement and test

IEC 61010-2-030, *Safety requirements for electrical equipment for measurement, control, and laboratory use – Part 2-030: Particular requirements for testing and measuring circuits*

IEC 61032:1997, *Protection of persons and equipment by enclosures – Probes for verification*

IEC 61243-3, *Live working – Voltage detectors – Part 3: Two-pole low-voltage type*

IEC 61326 (all parts), *Electrical equipment for measurement, control and laboratory use – EMC requirements*

IEC 61439-1, *Low-voltage switchgear and controlgear assemblies – Part 1: General rules*

IEC 61558 (all parts), *Safety of power transformers, power supplies, reactors and similar products*

IEC 62368-1, Audio/video, information and communication technology equipment – Part 1: Safety requirements

IEC 62471, Photobiological safety of lamps and lamp systems

IEC Guide 117, Electrotechnical equipment – Temperatures of touchable hot surfaces

ISO 8124-1, Safety of toys – Part 1: Safety aspects related to mechanical and physical properties

ISO 9241 (all parts), *Ergonomics of human-system interaction*

ISO 13732-1, Ergonomics of the thermal environment – Methods for the assessment of human responses to contact with surfaces – Part 1: Hot surfaces

ISO 13854, *Safety of machinery – Minimum gaps to avoid crushing of parts of the human body*

ISO 14121-1, *Safety of machinery – Risk assessment – Part 1: Principles*

ISO 14738, *Safety of machinery – Anthropometric requirements for the design of workstations at machinery*

ISO 14971, *Medical devices – Application of risk management to medical devices*

ANSI B11.TR3, *Risk Assessment and Risk Reduction – A Guide to Estimate, Evaluate and Reduce Risks Associated with Machine Tools*

ANSI/UL 248-14, *Low-Voltage Fuses – Part 14: Supplemental Fuses*

ANSI/UL 471, *Standard for Commercial Refrigerators and Freezers*

ANSI/UL 746E, *Standard for Polymeric Materials – Industrial Laminates, Filament Wound Tubing, Vulcanized Fibre, and Materials Used In Printed-Wiring Boards*

ANSI/UL 2556, *Wire and Cable Test Methods*

EN 71-1, *Safety of toys. Mechanical and physical properties*

EN 349, *Safety of machinery – Minimum gaps to avoid crushing of parts of the human body*

EN 894-2, *Safety of machinery – Ergonomics requirements for the design of displays and control actuators – Part 2: Displays*

EN 894-3, *Safety of machinery – Ergonomics requirements for the design of displays and control actuators – Part 3: Control actuators*

SEMI S8, *Safety Guidelines for Ergonomics Engineering of Semiconductor Manufacturing Equipment*

SEMI S10, *Safety guideline for risk assessment and risk evaluation process*

UL 1439, *Tests for Sharpness of Edges on Equipment*

ASTM F963, *Standard Consumer Safety Specification for Toy Safety*

ICRP Publication 36 *Protection against Ionizing Radiation in the Teaching of Science, International Commission on Radiological Protection (ICRP) (1983)*

ICNIRP EMF Guidelines, *Guidelines for limiting exposure to time-varying electric, magnetic, and electromagnetic fields (up to 300 GHz), International Commission on Non-Ionizing Radiation Protection (ICNIRP) (1998)*

*A Non-Binding Guide to the Artificial Optical Radiation Directive 2006/25/EC, Radiation Protection Division, Health Protection Agency, European Commission*

---



# British Standards Institution (BSI)

BSI is the independent national body responsible for preparing British Standards and other standards-related publications, information and services. It presents the UK view on standards in Europe and at the international level.

BSI is incorporated by Royal Charter. British Standards and other standardisation products are published by BSI Standards Limited.

## Revisions

British Standards and PASs are periodically updated by amendment or revision. Users of British Standards and PASs should make sure that they possess the latest amendments or editions.

It is the constant aim of BSI to improve the quality of our products and services. We would be grateful if anyone finding an inaccuracy or ambiguity while using British Standards would inform the Secretary of the technical committee responsible, the identity of which can be found on the inside front cover. Similar for PASs, please notify BSI Customer Services.

**Tel: +44 (0)20 8996 9001 Fax: +44 (0)20 8996 7001**

BSI offers BSI Subscribing Members an individual updating service called PLUS which ensures that subscribers automatically receive the latest editions of British Standards and PASs.

**Tel: +44 (0)20 8996 7669 Fax: +44 (0)20 8996 7001**

**Email: [plus@bsigroup.com](mailto:plus@bsigroup.com)**

## Buying standards

You may buy PDF and hard copy versions of standards directly using a credit card from the BSI Shop on the website [www.bsigroup.com/shop](http://www.bsigroup.com/shop). In addition all orders for BSI, international and foreign standards publications can be addressed to BSI Customer Services.

**Tel: +44 (0)20 8996 9001 Fax: +44 (0)20 8996 7001**

**Email: [orders@bsigroup.com](mailto:orders@bsigroup.com)**

In response to orders for international standards, BSI will supply the British Standard implementation of the relevant international standard, unless otherwise requested.

## Information on standards

BSI provides a wide range of information on national, European and international standards through its Knowledge Centre.

**Tel: +44 (0)20 8996 7004 Fax: +44 (0)20 8996 7005**

**Email: [knowledgecentre@bsigroup.com](mailto:knowledgecentre@bsigroup.com)**

BSI Subscribing Members are kept up to date with standards developments and receive substantial discounts on the purchase price of standards. For details of these and other benefits contact Membership Administration.

**Tel: +44 (0)20 8996 7002 Fax: +44 (0)20 8996 7001**

**Email: [membership@bsigroup.com](mailto:membership@bsigroup.com)**

Information regarding online access to British Standards and PASs via British Standards Online can be found at [www.bsigroup.com/BSOL](http://www.bsigroup.com/BSOL)

Further information about British Standards is available on the BSI website at [www.bsi-group.com/standards](http://www.bsi-group.com/standards)

## Copyright

All the data, software and documentation set out in all British Standards and other BSI publications are the property of and copyrighted by BSI, or some person or entity that own copyright in the information used (such as the international standardisation bodies) has formally licensed such information to BSI for commercial publication and use. Except as permitted under the Copyright, Designs and Patents Act 1988 no extract may be reproduced, stored in a retrieval system or transmitted in any form or by any means – electronic, photocopying, recording or otherwise – without prior written permission from BSI. This does not preclude the free use, in the course of implementing the standard, of necessary details such as symbols, and size, type or grade designations. If these details are to be used for any other purpose than implementation then the prior written permission of BSI must be obtained. Details and advice can be obtained from the Copyright & Licensing Department.

**Tel: +44 (0)20 8996 7070**

**Email: [copyright@bsigroup.com](mailto:copyright@bsigroup.com)**

## BSI

389 Chiswick High Road London W4 4AL UK

Tel +44 (0)20 8996 9001

Fax +44 (0)20 8996 7001

[www.bsigroup.com/standards](http://www.bsigroup.com/standards)