



BSI Standards Publication

# Pilot function through a control pilot circuit using PWM (pulse width modulation) and a control pilot wire

### **National foreword**

This Published Document is the UK implementation of IEC/TS 62763:2013.

The UK participation in its preparation was entrusted to Technical Committee PEL/69, Electric vehicles.

A list of organizations represented on this committee can be obtained on request to its secretary.

This publication does not purport to include all the necessary provisions of a contract. Users are responsible for its correct application.

© The British Standards Institution 2014.

Published by BSI Standards Limited 2014

ISBN 978 0 580 82419 7

ICS 43.120

**Compliance with a British Standard cannot confer immunity from legal obligations.**

This Published Document was published under the authority of the Standards Policy and Strategy Committee on 31 January 2014.

### **Amendments/corrigenda issued since publication**

<b>Date</b>	<b>Text affected</b>
-------------	----------------------

---



# TECHNICAL SPECIFICATION

---

**Pilot function through a control pilot circuit using PWM (pulse width modulation) and a control pilot wire**

INTERNATIONAL  
ELECTROTECHNICAL  
COMMISSION

PRICE CODE



---

ICS 43.120

ISBN 978-2-8322-1281-3

**Warning! Make sure that you obtained this publication from an authorized distributor.**

## CONTENTS

FOREWORD.....	4
INTRODUCTION.....	6
1 Scope.....	7
2 Normative references .....	7
3 Control pilot circuit.....	7
3.1 General.....	7
3.2 Typical pilot electric equivalent circuit .....	8
3.3 Simplified pilot electric equivalent circuit.....	9
3.4 Other requirements .....	9
4 Requirements for parameters .....	10
5 Test procedures for immunity of EV supply equipment to wide tolerances on the pilot wire and the presence of high frequency data signals on the pilot wire.....	25
5.1 General.....	25
5.2 Constructional requirements of the EV simulator .....	25
5.3 Test procedure.....	25
5.4 Test list – Oscillator frequency and generator voltage test .....	26
5.5 Duty cycle test .....	27
5.6 Pulse wave shape test .....	27
5.7 Sequences diagnostic – normal charge cycle .....	27
5.8 Open earth wire test.....	29
5.9 Test of short circuit values of the voltage .....	29
5.10 Example of a test simulator of the vehicle (informative).....	29
5.11 Optional hysteresis test.....	31
5.11.1 General .....	31
5.11.2 Test sequence for hysteresis between states B and C .....	32
5.11.3 Test sequence for hysteresis between states C-E, D-E .....	32
5.11.4 Test sequence for hysteresis between states C-D.....	32
Figure 1 – Typical control pilot electric equivalent circuit.....	8
Figure 2 – Simplified control pilot electric equivalent circuit .....	9
Figure 3 – State machine diagram for typical control pilot .....	15
Figure 4 – State machine diagram for simplified control pilot.....	15
Figure 5 – Normal operation cycle.....	27
Figure 6 – Simplified control pilot cycle .....	28
Figure 7 – Optional charge cycle test.....	29
Figure 8 – Example of a test circuit (EV simulator).....	30
Table 1 – Maximum allowable carrier signal voltages on pilot wire .....	10
Table 2 – Control pilot circuit parameters (see Figures 1 and 2).....	10
Table 3 – Vehicle control pilot circuit values and parameters .....	11
Table 4 – System states detected by the EV supply equipment.....	12
Table 5 – State behavior .....	14
Table 6 – List of sequences .....	16

Table 7 – Pilot duty cycle provided by EV supply equipment .....	24
Table 8 – Maximum current to be drawn by vehicle .....	24
Table 9 – Test resistance values .....	25
Table 10 – Parameters of control pilot voltages .....	26
Table 11 – Test parameters of control pilot signals at the measure point according to Figure 8 .....	27
Table 12 – Normal charge cycle test .....	28
Table 13 – Position of switches .....	31
Table 14 – Initial settings of the potentiometer at the beginning of each test .....	31

## INTERNATIONAL ELECTROTECHNICAL COMMISSION

---

### **PILOT FUNCTION THROUGH A CONTROL PILOT CIRCUIT USING PWM (PULSE WIDTH MODULATION) AND A CONTROL PILOT WIRE**

#### FOREWORD

- 1) The International Electrotechnical Commission (IEC) is a worldwide organization for standardization comprising all national electrotechnical committees (IEC National Committees). The object of IEC is to promote international co-operation on all questions concerning standardization in the electrical and electronic fields. To this end and in addition to other activities, IEC publishes International Standards, Technical Specifications, Technical Reports, Publicly Available Specifications (PAS) and Guides (hereafter referred to as "IEC Publication(s)"). Their preparation is entrusted to technical committees; any IEC National Committee interested in the subject dealt with may participate in this preparatory work. International, governmental and non-governmental organizations liaising with the IEC also participate in this preparation. IEC collaborates closely with the International Organization for Standardization (ISO) in accordance with conditions determined by agreement between the two organizations.
- 2) The formal decisions or agreements of IEC on technical matters express, as nearly as possible, an international consensus of opinion on the relevant subjects since each technical committee has representation from all interested IEC National Committees.
- 3) IEC Publications have the form of recommendations for international use and are accepted by IEC National Committees in that sense. While all reasonable efforts are made to ensure that the technical content of IEC Publications is accurate, IEC cannot be held responsible for the way in which they are used or for any misinterpretation by any end user.
- 4) In order to promote international uniformity, IEC National Committees undertake to apply IEC Publications transparently to the maximum extent possible in their national and regional publications. Any divergence between any IEC Publication and the corresponding national or regional publication shall be clearly indicated in the latter.
- 5) IEC itself does not provide any attestation of conformity. Independent certification bodies provide conformity assessment services and, in some areas, access to IEC marks of conformity. IEC is not responsible for any services carried out by independent certification bodies.
- 6) All users should ensure that they have the latest edition of this publication.
- 7) No liability shall attach to IEC or its directors, employees, servants or agents including individual experts and members of its technical committees and IEC National Committees for any personal injury, property damage or other damage of any nature whatsoever, whether direct or indirect, or for costs (including legal fees) and expenses arising out of the publication, use of, or reliance upon, this IEC Publication or any other IEC Publications.
- 8) Attention is drawn to the Normative references cited in this publication. Use of the referenced publications is indispensable for the correct application of this publication.
- 9) Attention is drawn to the possibility that some of the elements of this IEC Publication may be the subject of patent rights. IEC shall not be held responsible for identifying any or all such patent rights.

The main task of IEC technical committees is to prepare International Standards. In exceptional circumstances, a technical committee may propose the publication of a technical specification when

- the required support cannot be obtained for the publication of an International Standard, despite repeated efforts, or
- the subject is still under technical development or where, for any other reason, there is the future but no immediate possibility of an agreement on an International Standard.

Technical specifications are subject to review within three years of publication to decide whether they can be transformed into International Standards.

IEC/TS 62763, which is a technical specification, has been prepared by IEC technical committee 69: Electric road vehicles and electric industrial trucks.

Edition 2 of IEC 61851-1, published in 2010 is presently undergoing revision. This Technical Specification will be valid until the publication of Edition 3 of IEC 61851-1.

In this document, the numbers in square brackets at the beginning of a sentence, help to identify requirements.

The text of this technical specification is based on the following documents:

Enquiry draft	Report on voting
69/242/DTS	69/254/RVC

Full information on the voting for the approval of this technical specification can be found in the report on voting indicated in the above table.

This publication has been drafted in accordance with the ISO/IEC Directives, Part 2.

The committee has decided that the contents of this publication will remain unchanged until the stability date indicated on the IEC web site under "<http://webstore.iec.ch>" in the data related to the specific publication. At this date, the publication will be

- transformed into an International Standard,
- reconfirmed,
- withdrawn,
- replaced by a revised edition, or
- amended.

A bilingual version of this publication may be issued at a later date.

## INTRODUCTION

The pilot wire function described in this document has been designed as a control mechanism for the supply of electrical energy to electric vehicles, principally for the charging of the traction batteries of the vehicle. It concerns all charging systems that ensure the pilot function with a pilot wire circuit with PWM for mode 2, mode 3 and mode 4 charging as described in the IEC 61851 series. As indicated in the foreword, Edition 2 of IEC 61851-1, published in 2010 is presently undergoing revision. This Technical Specification will be valid until the publication of Edition 3 of IEC 61851-1.



## PILOT FUNCTION THROUGH A CONTROL PILOT CIRCUIT USING PWM MODULATION AND A CONTROL PILOT WIRE

### 1 Scope

This Technical Specification describes the pilot wire function designed as a control mechanism for the supply of electrical energy to electric vehicles, principally for the charging of the traction batteries of the vehicle. It concerns all charging systems that ensure the pilot function with a pilot wire circuit with PWM for mode 2, mode 3 and mode 4 charging as described in the IEC 61851 series.

This document describes the functions and sequencing of events for this circuit based on the recommended typical implementation circuit parameters. The parameters indicated also ensure the interoperability of control pilot wire systems designed according to SAE J1772.

This document is not applicable to vehicles using pilot functions that are not based on a PWM signal and a pilot wire.

NOTE 1 In the context of this document the words “EV supply equipment” designate any one of the following: the AC EV supply equipment in mode 3, the in cable control box in mode 2 and/or the DC EV supply equipment in mode 4.

NOTE 2 The control pilot wire is a supplementary conductor, in addition to the power lines linking the vehicle to EV supply equipment via the vehicle coupler.

### 2 Normative references

The following documents, in whole or in part, are normatively referenced in this document and are indispensable for its application. For dated references, only the edition cited applies. For undated references, the latest edition of the referenced document (including any amendments) applies.

IEC 61851-1:2010, *Electric vehicle conductive charging system – Part 1: General requirements*

IEC 61851-23<sup>1</sup>, *Electric vehicle conductive charging system – Part 23: D.C. electric vehicle charging station*

ISO/IEC 15118<sup>1</sup> (all parts), *Road vehicles – Vehicle to grid communication interface*

### 3 Control pilot circuit

#### 3.1 General

Two types of pilot functions are possible: simplified and typical.

- Simplified pilot function fulfils the basic requirements that are described in 6.4.1 of IEC 61851-1:2010.
- Typical pilot function fulfils the basic requirements that are described in 6.4.1 of IEC 61851-1:2010 and also allows the selection of charging rate as described in 6.4.2. of IEC 61851-1:2010.

---

<sup>1</sup> To be published.

Additional requirements for implementation in mode 4 system are described in IEC 61851-23.

Figures 1 and 2 show examples of the principle of operation of the control pilot circuit.

The EV (electric vehicle) supply equipment may cut off the power after at least 5 s in case the EV will use more current than the duty cycle indicates.

It is recommended to de-energize the system, if the measured current exceeds the current signalled by duty cycle with a tolerance of 10 %.

[RA03-010] The circuit parameters shall be designed in accordance with Table 2, Table 3 and 3.4.

[RA03-020] The functionality of the pilot line shall follow the requirements defined in Table 2, Table 6, Table 7, and Table 8.

This information may be provided to the pilot function controller by an energy management system.

### 3.2 Typical pilot electric equivalent circuit

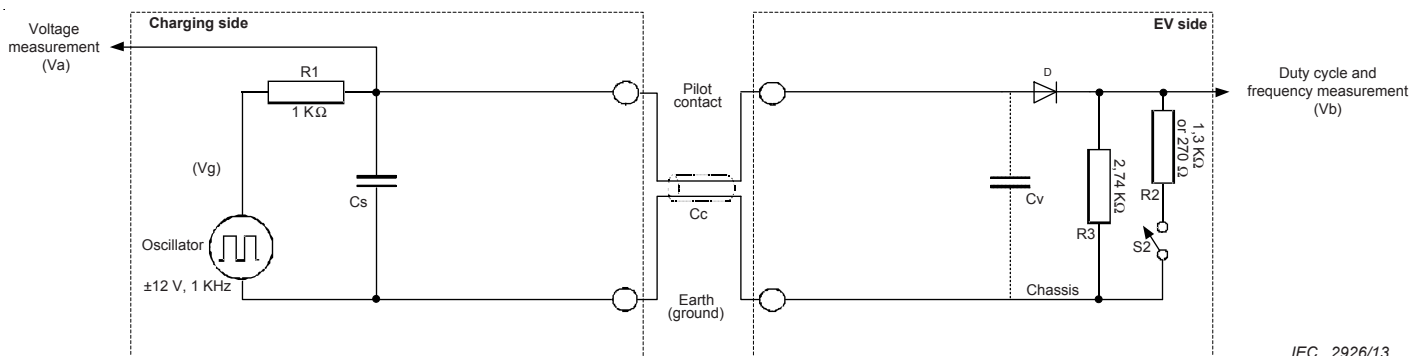

NOTE Inductive components can be included, but are not shown here.

**Figure 1 – Typical control pilot electric equivalent circuit**

The EV supply equipment communicates by setting the duty cycle of a PWM signal or a steady-state DC voltage of the pilot signal, (Table 7 and Table 8).

The EV supply equipment may change the duty cycle of the PWM at any time.

The EV communicates by loading the positive half-wave of the pilot signal.

For further information see also Table 3 and Table 4.

[RA03-030] Typical control pilot (Figure 1) shall support state B.

[RA03-040] Using a typical control pilot, the EV shall follow the PWM, Table 8.

NOTE The designations of R2 and R3 have been exchanged with respect to IEC 61851-1:2010..

### 3.3 Simplified pilot electric equivalent circuit

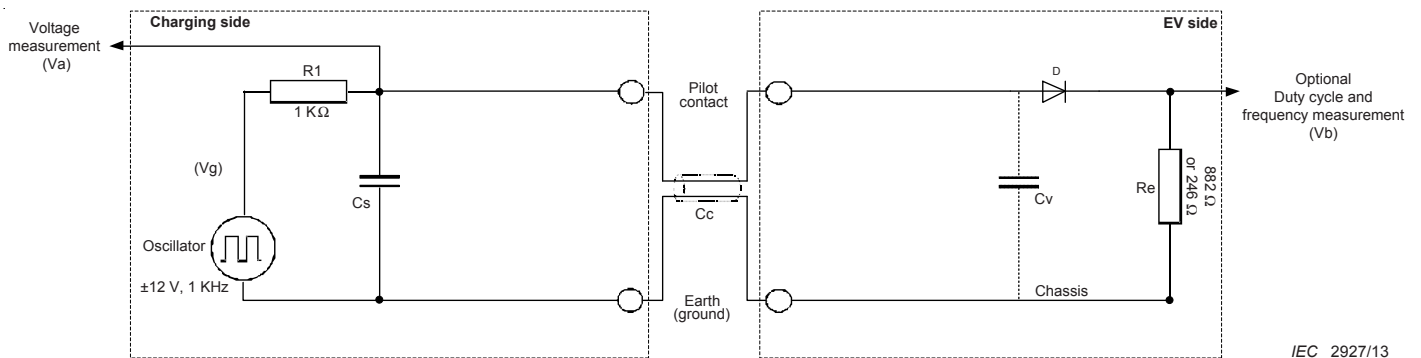

NOTE Inductive components can be included, but are not shown here.

**Figure 2 – Simplified control pilot electric equivalent circuit**

[RA03-050] EVs, designed with simplified circuit, shall be limited to single phase charging and not exceeding 10 A.

[RA03-060] For a system using the simplified control pilot, the EV supply equipment side shall modulate the PWM in the same manner as done for a system using a typical control pilot.

The simplified control pilot circuit gives an equivalent result to the circuit shown in Figure 1 as if the switch S2 is closed.

[RA03-070] In a simplified pilot circuit, state B does not exist.

[RA03-080] An EV using the simplified control pilot circuit, may measure the duty cycle.

[RA03-090] The EV supply equipment may cut off the power after at least 5 s in case the EV will use more current than the duty cycle indicates.

It is not recommended to use simplified pilot for new design.

For the EV in new design, it is recommended to follow the PWM.

NOTE In some countries simplified pilot is not allowed: US.

### 3.4 Other requirements

[RA03-100] Additional components required for signal coupling shall not cause the control pilot duty cycle signal, to get deformed beyond the limits defined in Table 7 and tested as in 5.5.

[RA03-110] Any impedance inserted in series with the pilot wire, at the EV supply equipment shall not have a total inductance of more than 1 mH (Lse).

[RA03-120] Any impedance inserted in series with the pilot wire, at the EV shall not have a total inductance of more than 1 mH (Lsv).

[RA03-130] Any inductive impedance inserted in series with the pilot wire shall be resistively damped to avoid high frequency oscillation of the PWM signal.

When using high frequency signals for digital communication the following requirements have to be taken into account.

[RA03-140] The additional signal shall have a frequency of at least 148 kHz.

[RA03-150] The voltage of the high frequency signal shall be in accordance with the values given in Table 1.

Digital communication standard is described in the ISO/IEC 15118 series.

NOTE One further capacitive (max of 2 000 pF) branch can be used for injection of the additional signals provided the resistance impedance to ground is greater than 10 k $\Omega$ . Such capacitive/resistive branch would typically be used for signal inputs and automatic signal voltage control (refer to Table 1).

**Table 1 – Maximum allowable carrier signal voltages on pilot wire**

Frequency (kHz)	Max peak/peak voltage (V)
148 to 249	0,4
250 to 499	0,6
500 to 1 000	1,2
> 1 000	2,5

#### 4 Requirements for parameters

**Table 2 – Control pilot circuit parameters (see Figures 1 and 2)**

Parameter <sup>a</sup>	Symbol	Value	Units	Remark
Generator open circuit positive voltage <sup>c</sup>	Voch	12 ( $\pm$ 0,6)	V	
Generator open circuit negative voltage <sup>c</sup>	Vocl	-12 ( $\pm$ 0,6)	V	
Frequency generator output	Fo	1 000 ( $\pm$ 2%)	Hz	The EV shall detect the frequency In case the frequency is outside of 1 kHz the EV should not charge. For simplified control pilot this is not applicable
Pulse width <sup>b c</sup>	Pwo	Per Table 7 ( $\pm$ 5 $\mu$ s)	$\mu$ s	
Maximum rise time (10 % to 90 %) <sup>c</sup>	Trg	2	$\mu$ s	
Maximum fall time (90 % to 10 %) <sup>c</sup>	Tfg	2	$\mu$ s	
Maximum settling time to 95 % steady state <sup>c</sup>	Tsg	3	$\mu$ s	
Equivalent source resistance	R1	1 000 $\pm$ 3 %	$\Omega$	970 $\Omega$ to 1 030 $\Omega$ 1 % equivalent resistors commonly recommended
EV supply equipment capacitance <sup>d</sup>	Cs	Max 1 600 Min 300	pF	
Cable capacitance	Cc	Max 1 500	pF	Case B (cord set)
EV capacitance <sup>e</sup>	Cv	Max 2 400	pF	
Stray and additional components				
Damping resistance	Rse,	100 to 1 000	$\Omega$	Typical values (may be included in ferrite losses)

	Rsv			
Optional additional series inductance	Lse	1	mH	Maximum value allowed on off board EV supply equipment
	Lsv	1	mH	Maximum value allowed on vehicle
NOTE 1 Va can be measured at the pilot terminal of the socket outlet or connector during state A (see Clause 4).				
NOTE 2 Cases A to C (as defined in IEC 61851-1) refer to the topology of the charging cable:				
<ul style="list-style-type: none"> <li>- case A: cable permanently attached to the vehicle, fitted with a plug;</li> <li>- case B: separate cable, fitted with plug and vehicle connector;</li> <li>- case C: cable permanently attached to the charging post, fitted with a vehicle connector.</li> </ul>				
<sup>a</sup> Tolerances to be maintained over the full useful life and under environmental conditions as specified by the manufacturer. <sup>b</sup> Measured at 0 V crossing of the 12 V signal. <sup>c</sup> Measured at point Vg as indicated on Figure 1. <sup>d</sup> For case C the max equivalent capacitance is total of Cc + Cs. <sup>e</sup> For case A the max equivalent capacitance is total of Cc + Cv.				

[RA04-010] Vehicle control pilot circuit values and parameters as indicated on Figures 1 and 2 are given in Table 3.

**Table 3 – Vehicle control pilot circuit values and parameters**

Parameter	Symbol	Value	Value range	Units
Permanent resistor value	R3	2,740	2 658 to 2 822	Ω
Switched resistor value for vehicles not requiring ventilation	R2 State Cx	1,300	1 261 to 1 339	Ω
Switched resistor value for vehicles requiring ventilation	R2 State Dx	270	261,9 to 278,1	Ω
Equivalent total resistor value no ventilation (Figure 2)	Re State Cx	882	856 to 908	Ω
Equivalent total resistor ventilation required (Figure 2)	Re State Dx	246	239 to 253	Ω
Diode voltage drop (2,75 mA, to 10 mA, - 40 °C to + 85 °C) Fast turn-off diode (Tr < 200 ns) Vr > 50 V	Vd	0,7	0,55 to 0,85	V
Maximum total equivalent input capacitance	Cv	2 400	N/A	pF

[RA04-020] Value ranges shall be maintained over full useful life and under design environmental conditions.

1 % resistors are commonly recommended for this application.

The Table 4 details the pilot voltage ranges as a result of Tables 2 and 3 components values. These voltage ranges apply to the EV supply equipment (Va).

**Table 4 – System states detected by the EV supply equipment**

Va <sup>a</sup>			PWM status	System state	EV connected to the EV supply equipment	S2 <sup>f</sup>	EV ready to receive energy <sup>g</sup>	EV supply equipment ready to supply energy <sup>h</sup>	EV supply equipment supply energy	Remark
Lower level (v)	Nominal (v)	Higher level (v)								
11	12 <sup>d</sup>	13	Off	A1	no	N/A	No	Not ready	Off	Vb = 0 V
11	12 <sup>d</sup>	13	On	A2 <sup>e i</sup>			No	Ready	Off	
10		11	N/A	Ax or Bx <sup>j</sup>	no/yes	open	No	N/A	Off	
8	9 <sup>b</sup>	10	Off	B1	yes	open	No	Not ready	Off	Re = R3 = 2,74 kΩ detected
8	9 <sup>b</sup>	10	On	B2 <sup>e i</sup>			No	Ready	Off	
7		8	N/A	Bx or Cx <sup>j</sup>		open/close	N/A	State dependent		
5	6 <sup>c</sup>	7	Off	C1		close	Yes	Not ready	Off	Re = 882 Ω detected
5	6 <sup>c</sup>	7	On	C2 <sup>e,i</sup>			Yes	Ready	On	
4		5	Off	Cx or Dx <sup>j</sup>			Yes	State dependent		
2	3 <sup>c</sup>	4	Off	D1			Yes	Not ready	Off	Re = 246 Ω detected
2	3 <sup>c</sup>	4	On	D2 <sup>e i</sup>		Yes	Ready	On	Charging area ventilation required	
1	N/A	2	N/A	Dx or E <sup>j</sup>			open	State dependent		
-1	0	1	Off	E		N/A	N/A	No	Not ready	Off
-13	-12	-11	Off	F	N/A	N/A	No	Not ready	Off	EV supply equipment not available
-13	-12	-11	On	x2	yes	N/A	State dependent		Low side of PWM signal	

Voltage values, Va, as indicated in the table are informative, actual values to be tested according to Clause 5.

- a All voltages are measured after stabilization period.
- b The EV supply equipment generator may apply a steady state DC voltage or a 12 V square wave during this period. The duty cycle indicates the available current as in Table 7.
- c The voltage measured is function of the value of R2 in Figure 1 (indicated as Re in Figure 2).
- d 12 V static voltage.
- e The EV supply equipment shall check pilot line low state of -12 V, diode presence, at least once before the closing of the supply switch on the EV supply equipment.
- f S2 = switch contacts in the EV.
- g EV ready to receive energy = EV ready to be charged by closing S2 contacts.
- h EV supply equipment ready to supply energy = ready – PWM on, not ready – PWM off.
- i Negative voltage range tolerances of the PWM are defined by “Low side of PWM signal” row (last row).
- j A control pilot circuit defines its own trigger level to separate the states inside this voltage range. It is recommended to use different trigger levels depending on the direction of the state change to include hysteresis behaviour.

There is no undefined voltage range, for the control pilot, between the system states.

The state is valid if it is within the above values, the state detection shall be noise resistant, e.g. against EMC and high frequency data signals on the pilot wire.

NOTE 1 Reliable detection of a state change can require measurements during a few milliseconds or a few PWM cycles.

[RA04-030] The EV supply equipment shall verify that the EV is properly connected by verifying the presence of the diode in the pilot circuit, before energizing the system. This shall be done at the transition from x1 to x2 or at least once during state x2, before closing the switching device. Presence of the diode is detected if the low side of the pilot pulse is within the voltage range defined in Table 4.

[RA04-040] The EV supply equipment shall open or close the switching device within the time indicated in Table 6.

[RA04-050] When not in State C or D, the EV supply equipment shall open the supply switching device within 100 ms.

Compliance is tested as in Clause 5.

NOTE 2 The EV supply equipment can attempt to retry the charging sequence in case a valid state is recognized.

NOTE 3 In some countries, in case of a short circuit between the control pilot and earth, a max time of 3 s is allowed to open the switching device according to SAE J1772:2012: US.

The state changes between A, B, C and D are caused by the EV or by the user.

The state changes between x1 and x2 are created by the EV supply equipment.

A change between state x1 and x2 indicates an unavailability or unavailability of power to the EV.

**Table 5 – State behavior**

States	Behaviour	Remark
x1 <sup>a</sup>	The EV supply equipment is not capable to deliver energy, either due to the lack of available power in the grid, or to the EV supply equipment intentionally stopping for intermittent charging.	If energy is available, the EV supply equipment shall change to x2 <sup>b</sup> . The EV can use this as a trigger to start or resume charging.
State E	No power to the EV supply equipment (e.g. AC voltage outage). Short circuit of control pilot to PE.	The EV supply equipment unlocks the socket outlet at maximum of 30 s, if any.
State F	Unavailability of the EV supply equipment (e.g. the EV supply equipment can't give service, software upgrade etc.).	The EV supply equipment unlocks the socket outlet at maximum of 30 s, if any.
<p><sup>a</sup> State x1 can be referred to A1 or B1 or C1 or D1.</p> <p><sup>b</sup> State x2 can be referred to B2 or C2 or D2.</p> <p>NOTE 1 In case of a power outage and the EV supply equipment has a backup battery, it can stay in state x1; after the drainage of the battery, it needs to reach state E.</p> <p>NOTE 2 In case of case B and the cable belonging to the EV supply equipment owner, an unlock is under the EV supply equipment owner's decision.</p> <p>NOTE 3 In case of state F and the EV supply equipment is able to unlock the socket outlet via user interaction (e.g. authorisation) there is no need to unlock in 30 s.</p>		

It is not recommended to use the F state to signal unavailability of energy to the EV. State x1 gives the same information.

The state E may be caused by any number of difficulties and shall not be used as a signalling state to convey specific information.

When plug-in and authentication (e.g. RFID, payment, etc.) is needed, the pilot line shall stay at x1 as long as the energy is not allowed to be supplied.

In case, no authentication is needed, the system can go to x2.

See Figures 3 and 4 for state machine diagrams.



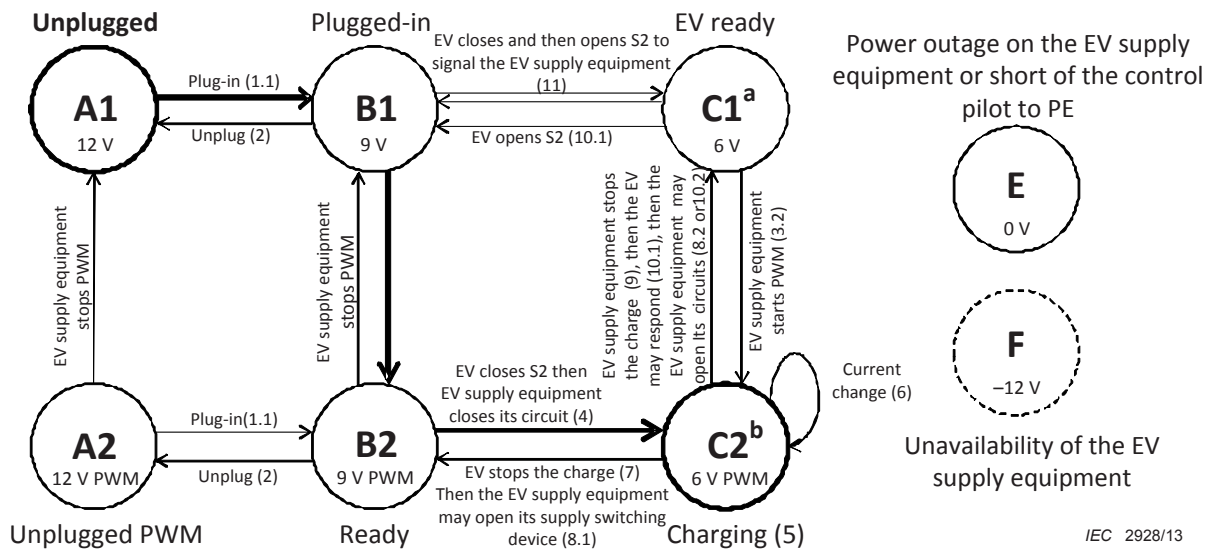

Numbers in brackets refer to the sequence reference in Table 6.

NOTE A change from any state to states Ax, E or F may take place at any time.

<sup>a</sup> Can be state D1, 3 V.

<sup>b</sup> Can be state D2, 3 V PWM.

**Figure 3 – State machine diagram for typical control pilot**

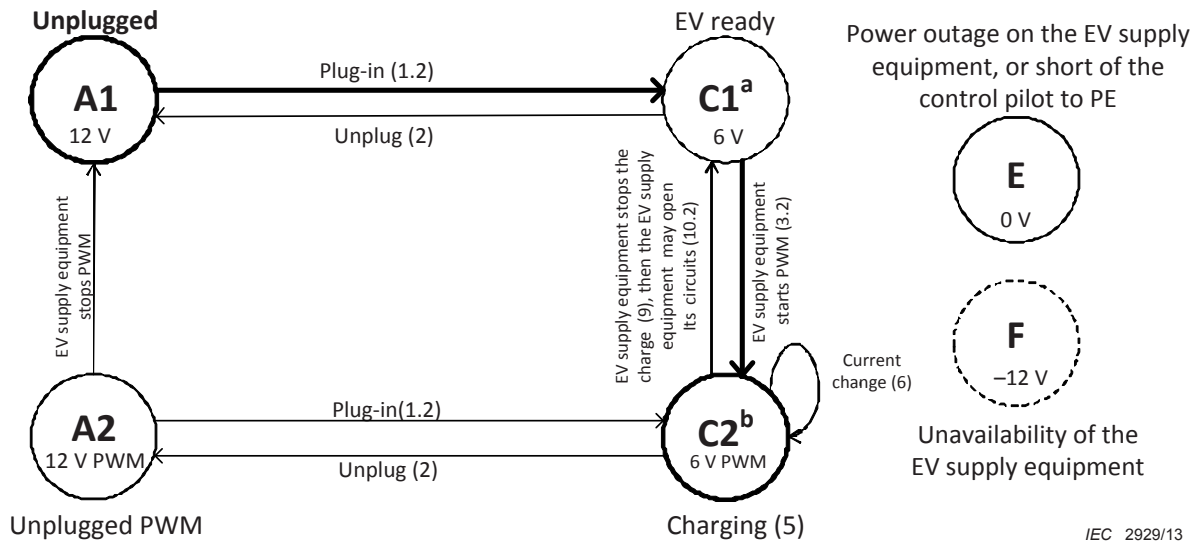

Numbers in brackets refer to the sequence reference in Table 6.

NOTE 1 A change from any state to states Ax, E or F may take place at any time.

NOTE 2 Simplified pilot not supported in J1772:2012.

<sup>a</sup> Can be state D1, 3 V.

<sup>b</sup> Can be state D2, 3 V PWM.

**Figure 4 – State machine diagram for simplified control pilot**

**Table 6 – List of sequences**

Seq		State or transition	Conditions	Timing
1.1 Plug-in (with S2)		A1	(1) EV not connected +12 V.	t <sub>1-2</sub> No max (3)
		A1→B1	(2) The cable assembly is connected to the vehicle and to the EV supply equipment, +9 V.  NOTE 1 This sequence is also applicable from A2→B2.	
1.2 Plug-in (w/o S2 or S2 always in close position)		A1	(1) EV not connected +12 V.	t <sub>1-3</sub> No max (3)
		A1→C1/D1	(3) The cable assembly is connected to the vehicle and to the EV supply equipment, +6 V. NOTE 2 This sequence indicates that the EV operates in simplified pilot function. NOTE 3 This sequence is also applicable from A2→C2/D2. NOTE 4 t <sub>2</sub> does not exist in this sequence. NOTE 5 In case of sequence 1.2, the EV supply equipment can assume that the EV operates in simplified control pilot and may not follow the current limitation indication by PWM.  Simplified pilot not supported in SAE J1772:2012.	

Seq		State or transition	Conditions	Timing
2.1 Unplug at state Bx		B2→A2 or B1→A1	(19) Plug disconnected from the EV supply equipment or EV connector disconnected from the inlet.  Delay for turning off the square wave oscillator after transition from state B2, C2 or D2 to state A1 via A2 (or from B2, C2 or D2 to A1).	T <sub>19-20</sub> No max (3)
2.2 Unplug during charging		C2, D2 → A2	(19) Plug disconnected from the EV supply equipment or EV connector disconnected from the inlet during charging, the EV supply equipment switching devices shall be open under load.	Max 100 ms
		A2 → A1	Delay for turning off the square wave oscillator.  NOTE 6: SAE J1772:2012 defines a max time of 2 s.	No max (3)
		A1 or A2	(20) EV not connected.  The EV supply equipment shall allow removal of the plug automatically, at a maximum of 5 s, when entering state A (case A or B) unless the locking was initiated through user interaction (e.g. authorization). Then unlocking can be done only by using the adequate user interaction or both.  In case A, EV with attached cable, a switch may be added on the pilot line, on the EV side (cable, plug, vehicle), to simulate the EV disconnection (state A).	
			(20) EV not connected  The EV supply equipment shall allow removal of the plug automatically, at a maximum of 5 s, when entering state A (case A or B) unless the locking was initiated through user interaction (e.g. authorization). Then unlocking can be done only by using the adequate user interaction or both. In case A, EV with attached cable, a switch may be added on the pilot line, on the EV side (cable, plug, vehicle), to simulate the EV disconnection (state A); an EV that uses this, needs to make sure that the load is below 1 A.	

Seq		State or transition	Conditions	Timing
3.1 EV supply equipment power available (state B)		B1→B2	<p>(5) The EV supply equipment is now able to supply power, and indicates the available current by the PWM duty cycle.</p> <p>The EV shall recognize the change of state from B1 to B2.</p> <p>NOTE 7 This sequence can take place in the beginning of a charging session or to resume a charging session.</p>	<p>t4-5 No max (3)</p>
3.2 EV supply equipment Power available (state C)		C1→C2	<p>(5) The EV supply equipment is now able to supply energy, and indicates the available current by the PWM duty cycle.</p> <p>(6) The EV is ready to receive energy.</p> <p>(7) EV supply equipment energizes the system. If state D2 is detected, the supply will close only if ventilation requirements are met.</p>	<p>t4-5 No max (3)</p> <p>t5-6 0s t6-7 Max 3 s</p>
4 EV ready to charge		<p>B2→C2,D2</p> <p>C2,D2</p>	<p>(6) The EV is ready to receive energy.</p> <p>(7) EV supply equipment energizes the system. If state D2 is detected, the supply will close only if ventilation requirements are met.</p> <p>In case an EV asks for ventilation delay, ventilation command turns on after transition from state C2 to state D2 in 3 s. In case the EV supply equipment does not have ventilation, it shall open its switching devices and may change to state x1.</p> <p>NOTE 8 In case of 5% duty cycle, the amount of current is indicated by the digital communication, the EV supply equipment may close the supply switches only after the authorization given by digital communication.</p>	<p>t6-7 Max 3 s</p>

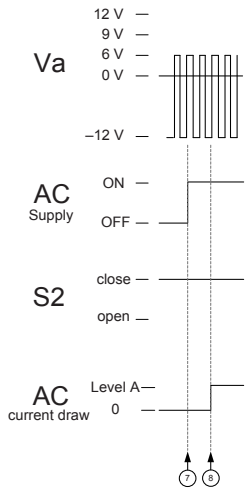
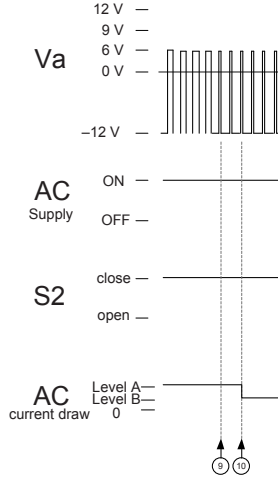
Seq		State or transition	Conditions	Timing
5 EV start charging	 <p>The diagram shows four signals over time. Va is a PWM signal with a peak of 12V and a trough of -12V. AC Supply is a step function that transitions from OFF to ON. S2 is a step function that transitions from open to close. AC current draw is a step function that transitions from 0 to Level A. Vertical dashed lines indicate the start of the PWM signal at time 7 and the start of the AC supply at time 8.</p>	C2,D2	<p>(8) Charge current drawn by the EV.</p> <p>NOTE 9 SAE J1772:2012 defines no min.</p>	<p>t7-8 Min 100 ms</p>
6 Current change	 <p>The diagram shows four signals over time. Va is a PWM signal with a peak of 12V and a trough of -12V. AC Supply is a step function that transitions from OFF to ON. S2 is a step function that transitions from open to close. AC current draw is a step function that transitions from 0 to Level A, then to Level B, and back to 0. Vertical dashed lines indicate the start of the PWM signal at time 9 and the start of the AC supply at time 10.</p>	C2,D2	<p>(9) The EV supply equipment indicates for a change of current. Such a demand may originate from the grid or by manual setting on EV supply equipment.</p> <p>The duty cycle can be changed at any time to any valid duty cycle.</p> <p>In normal operation, during the 5 s of the adjustment, the EV supply equipment shall not use sequence 6 for changing the PWM.</p> <p>(10) The EV adjusts the maximum current draw to be equal or below the PWM.</p> <p>The EV shall answer to this change.</p>	<p>Max 10 s From initiation (EV supply equipment gets the status) till EV responds</p> <p>t9-10 Max 5 s</p>

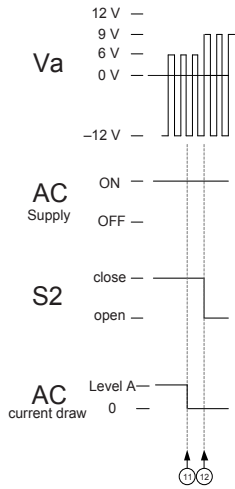
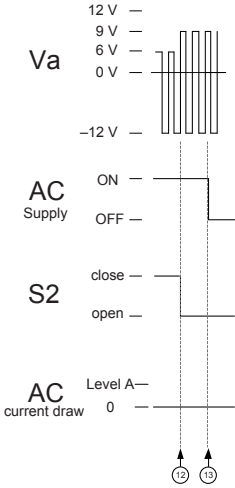
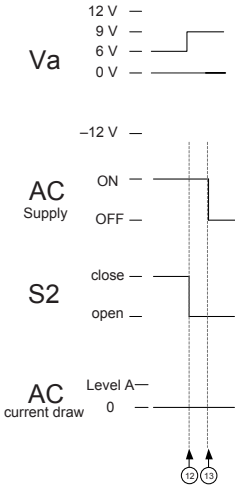
Seq		State or transition	Conditions	Timing
7 EV stops the charge	 <p>The diagram shows four signals over time. Va is a PWM signal between 0V and 12V. AC Supply is ON during the PWM and OFF after. S2 is close during the PWM and opens after. AC current draw is at Level A during the PWM and drops to 0 after. Vertical dashed lines mark time points t1 and t2.</p>	C2, D2	<p>(11) In normal operation an EV shall decrease the current draw to minimum (less than 1 A) before opening S2.</p> <p>During a non normal operation (emergency) the EV may open S2 immediately.</p>	t1-t2 No max (3)
8.1 EV supply equipment responds to EV opens S2 (with PWM)	 <p>The diagram shows four signals. Va is a PWM signal between 0V and 12V. AC Supply is ON during the PWM and OFF after. S2 is close during the PWM and opens after. AC current draw is at Level A during the PWM and drops to 0 after. Vertical dashed lines mark time points t2 and t3.</p>	B2	<p>(13) The EV supply equipment shall open its switching device responding to a state change from state C2/D2 to state B2 (considered as abnormal situation, S2 may open under load).</p> <p>NOTE 11 SAE J1772:2012 defines a max time of 3 s.</p>	t2-t3 Max 100 ms
8.2 EV supply equipment responds to EV opens S2 (w/o PWM)	 <p>The diagram shows four signals. Va is a step signal from 0V to 12V. AC Supply is ON during the step and OFF after. S2 is close during the step and opens after. AC current draw is at Level A during the step and drops to 0 after. Vertical dashed lines mark time points t2 and t3.</p>	B1	<p>(13) The EV supply equipment shall open its switching device responding to a state change from state C1/D1 to state B1.</p> <p>An EV using the simplified pilot circuit is not able to generate this sequence.</p> <p>Simplified pilot is not supported in SAE J1772:2012.</p>	t2-t3 Max 100 ms

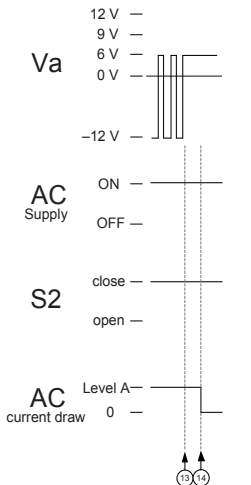
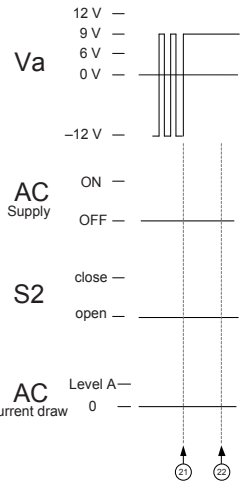
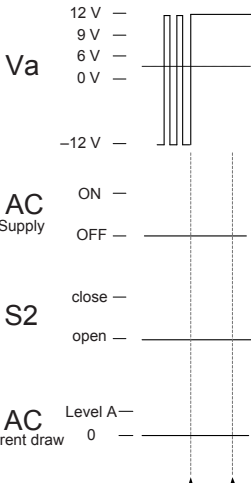
Seq		State or transition	Conditions	Timing	
9.1 EV supply equipment requests to stop charging	 <p>The diagram shows four signals over time. Va (top) starts at 0V, then has a series of pulses between 0V and 12V. AC Supply (second) is ON during the pulses and OFF otherwise. S2 (third) is 'close' during the pulses and 'open' otherwise. AC current draw (bottom) is at 'Level A' during the pulses and at '0' otherwise. Vertical dashed lines mark transitions 13 and 14.</p>	C2,D2 → C1,D1	(13) EV supply equipment may adjust the duty cycle to steady state in order to indicate the EV to stop the current draw.	t <sub>13-14</sub> Max 3 s	
		C1,D1	(14) The EV may respond to the steady state PWM, and stops the current draw.		
In case the EV will not follow the PWM the EV supply equipment may open its switching devices.					
9.2 EV supply equipment stops PWM at state B	 <p>The diagram shows four signals. Va (top) has a series of pulses between 0V and 12V. AC Supply (second) is ON during the pulses and OFF otherwise. S2 (third) is 'close' during the pulses and 'open' otherwise. AC current draw (bottom) is at 'Level A' during the pulses and at '0' otherwise. Vertical dashed lines mark transitions 21 and 22.</p>	B2 → B1	(21) EV supply equipment may stop the PWM at any time. (22) No action by the EV needs to take place.  In case sequence 3.1 will follow sequence 9.2, the EV supply equipment shall wait at least 3 s.	T <sub>21-22</sub> No max	
9.3 EV supply equipment stops PWM at state A	 <p>The diagram shows four signals. Va (top) has a series of pulses between 0V and 12V. AC Supply (second) is ON during the pulses and OFF otherwise. S2 (third) is 'close' during the pulses and 'open' otherwise. AC current draw (bottom) is at 'Level A' during the pulses and at '0' otherwise. Vertical dashed lines mark transitions 23 and 24.</p>	A2 → A1	(23) EV supply equipment may stop the PWM at any time. (24) No action by the EV needs to take place. EV disconnected  NOTE 12 SAE J1772:2012 defines a max time of 2s.	T <sub>23-24</sub> No max	

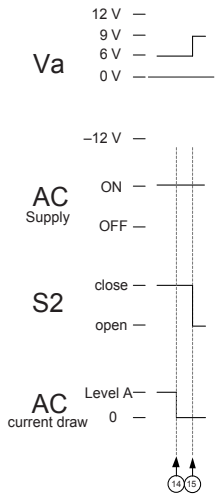
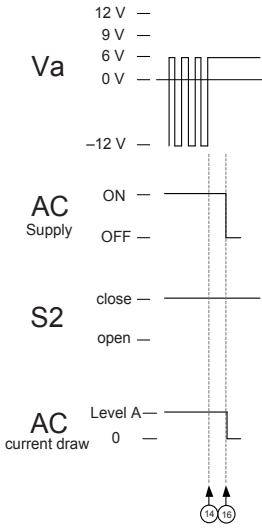
Seq		State or transition	Conditions	Timing
10.1 EV responds to stop charging request	 <p>The diagram shows four signals over time: Va (0V to 12V), AC Supply (ON/OFF), S2 (close/open), and AC current draw (Level A/0). Vertical dashed lines mark transitions 14 and 15.</p>	C1,D1	(14) The EV may respond to the steady state PWM, and stops the current draw.	t14-15
		C1,D1→B1	(15) The EV opens S2.	Max 3 s
<p>This sequence shall be followed by Sequence 8.2</p> <p>An EV using the simplified pilot circuit is not able to generate this sequence.</p> <p>Simplified pilot not supported in SAE J1772:2012.</p>				
10.2 EV does not respond to a stop charging request	 <p>The diagram shows four signals over time: Va (0V to 12V), AC Supply (ON/OFF), S2 (close/open), and AC current draw (Level A/0). Vertical dashed lines mark transitions 14 and 16.</p>	C1,D1	(14) The EV does not respond to the steady state PWM, and does not stop the current draw.	t14-16
		C1,D1	(16) The EV supply equipment shall open its switching device under load. (Timer starts upon the PWM change)	Min 3 s Max 5 s
<p>NOTE 13 t15 does not exist due to no change of S2 in this sequence.</p> <p>Simplified pilot not supported in SAE J1772:2012.</p>				



Seq		State or transition	Conditions	Timing
11 EV signal to the EV supply equipment	<p>The diagram shows four signals over time. Va (control pilot) starts at 12V, drops to 9V, then 6V, and finally to 0V. AC Supply starts ON and then transitions to OFF. S2 (switching contacts) starts in the 'close' position and transitions to 'open'. AC current draw starts at Level A and then drops to 0. Vertical dashed lines indicate the timing of state transitions 17 and 18.</p>	Bx→Cx/Dx →Bx	(17, 18) A transition from state Bx to Cx or Dx and Cx or Dx to Bx.  The EV supply equipment shall not move to state F due to sequence 11.  This sequence is optional, and shall be used only with digital communication (ISO/IEC 15118 series). This sequence may be used by the EV in order to signal the EV supply equipment. (e.g. wakeup the digital modem).  In any case the EV shall not draw current during this sequence.	t17-18  Min 200 ms  Max 3 s
12		XX→E  XX→F	Changing from any state to state E, the EV supply equipment switching device shall be open.  EV shall open S2, if any.  The EV supply equipment unlocks the socket-outlet if any.	Max 100 ms  Max 3 s  Max 30 s
<ul style="list-style-type: none"> <li>• Va – Voltage of the control pilot at the socket outlet or at the vehicle connector.</li> <li>• AC supply – Status of the relays/contactors at the EV supply equipment (EV supply equipment is ready to supply energy).</li> <li>• S2 – Switching contacts terminals of the EV switch.</li> <li>• AC current draw – Status of the relays/contactors in the EV (EV can take power).</li> </ul>				
It is not recommended to stop the PWM signal (move to state x1) more than 5 times during charge session (plug in to unplug).				
It is recommended that the EV supply equipment will resume the PWM on the EV request (sequences 4 and 11).				
The indication “no maximum” implies that the delay time has no constraints and may depend on external influences and the conditions existing on the EV supply equipment or the EV.				
If locking is used, the EV supply equipment shall lock the socket-outlet at least before energizing the EV.				
The EV supply equipment shall allow removal of the plug when entering state A (sequence 2, case B).				

**Table 7 – Pilot duty cycle provided by EV supply equipment**

Nominal duty cycle provided by EV supply equipment	Available line current
0 % duty cycle, continuous -12 V	EV supply equipment not available – State F.
5 % duty cycle	A duty cycle of 5 % indicates that digital communication is required and shall be established between the EV supply equipment and EV before charging.  In case the EV supply equipment changes the duty from 5 % to any valid duty cycle, this change of duty cycle shall be done through state x1 for a minimum of 3s.
(% duty cycle) = current[A] / 0,6 10 % ≤ duty cycle ≤ 85 %	Current from 6 A to 51 A
(% duty cycle) = (current[A] / 2,5) + 64 85 % < duty cycle ≤ 96 %	Current from 51 A to 80 A
100 % duty cycle, continuous positive voltage.	No current available (0 A) – state x1 (see Table 5)

NOTE Duty cycle tolerances are indicated in Table 2.

**Table 8 – Maximum current to be drawn by vehicle**

Nominal duty cycle interpretation by vehicle	Maximum current to be drawn by vehicle
Duty cycle < 3 %	Charging not allowed
3 % ≤ duty cycle ≤ 7 %	A duty cycle of 5 % indicates that digital communication is required and shall be established between the EV supply equipment and EV before charging.  Charging is not allowed without digital communication.  Digital communication may also be used with other duty cycles.
7 % < duty cycle < 8 %	Charging not allowed
8 % ≤ duty cycle < 10 %	6 A
10 % ≤ duty cycle ≤ 85 %	Available current = (% duty cycle) × 0,6 A
85 % < duty cycle ≤ 96 %	Available current = (% duty cycle – 64) × 2,5 A
96 % < duty cycle ≤ 97 %	80 A
Duty cycle > 97 %	Charging not allowed
<p>If the PWM signal is between 8 % and 97 %, the maximum current may not exceed the values indicated by the PWM even if the digital signal indicates a higher current.</p> <p>If the PWM signal is between 8 % and 97 % and there is a digital communication established, the maximum current may not exceed the lower values of either the PWM or the digital communication.</p> <p>In 3-phase systems, the duty cycle value indicates the current limit per each phase.</p> <p>The current indicated by the PWM signal shall not exceed the current cable capability and the EV supply equipment capability; the lower between them applies.</p> <p>The EV supply equipment can start at any valid value of the duty cycle, and may change during charging.</p>	

## 5 Test procedures for immunity of EV supply equipment to wide tolerances on the pilot wire and the presence of high frequency data signals on the pilot wire

### 5.1 General

This section describes tests that ensure the interoperability of vehicles and charging systems using the control pilot function with PWM modulation. The charging systems are designed to be in conformity with the parameters as defined in Clauses 3 and 4. However, it is necessary for the charging system to be tolerant to slight parameter changes (due for example to poor contacts or leakage on the pilot wire system) in order to ensure reliable charging of vehicles under most conditions.

### 5.2 Constructional requirements of the EV simulator

Testing is done using an EV simulator on the pilot wire that allows the testing in normal operation and at the tolerance limits allowed for the voltage and including the imposition of a high frequency signal on the pilot wire. The test scheme described in this clause allows the testing of the EV supply equipment when in normal operation and when subjected to high frequency imposed signals on the pilot wire.

[RA05-010] An EV simulator shall have the possibility of testing the EV supply equipment with all three possible resistor values as indicated in Table 9 with the following values for the other components.

- $C_v$  will use the maximum value from Table 2 (including the 1 000 pF of the generator).
- $L_{sv}$  will use the maximum value only from Table 2.
- $R_{sv}$  will use the minimum value from Table 2.
- $C_c$  will use the maximum value from Table 2.
- The high frequency test signal shall be injected at the EV supply equipment outlet for cases A and B, and at the coupler for case C.
- The diode shall conform with the specifications in Table 3.
- Resistor values shall be within a tolerance of 0,2 % of the value indicated in Table 9.

**Table 9 – Test resistance values**

	<b>R3 (<math>\Omega</math>)</b>	<b>R2 State Cx (<math>\Omega</math>)</b>	<b>R2 State Dx (<math>\Omega</math>)</b>
Maximum value	4 610	1 723	448
Nominal value	2 740	1 300	270
Minimum value	1 870	909	140
This table is not applicable to values used on vehicles (see Table 3).			

NOTE An example of a test setup is described in Figure 8

### 5.3 Test procedure

[RA05-020] The proper function of the EV supply equipment shall be tested under the following conditions.

[RA05-030] A sine wave generator with an impedance of 50  $\Omega$  is connected to the control pilot line via a 1 000 pF capacitor.

[RA05-040] The output amplitude of the sine wave generator is set so that the high frequency voltage component on the pilot wire is 2,5 V peak-peak.

The control of the imposed high frequency test component voltage shall be measured on the plug or socket outlet, as close as possible to the EV supply equipment.

During the test it is necessary to adjust the voltage of the generator.

[RA05-050] The frequency of the sine wave generator shall sweep through the frequency range from 1 MHz to 30 MHz with a logarithmic step width of 4 % and a holding time of 0,5 s.

[RA05-060] Unless otherwise specified, input voltage from power supply shall be the rated value, within the range of its tolerance.

[RA05-070] Unless otherwise specified, the tests shall be carried out in a draught-free location and at an ambient temperature of  $20\text{ °C} \pm 5\text{ °C}$ .

[RA05-080] The tests shall be carried out with the specimen, or any movable part of it, placed in the most unfavourable position which may occur in normal use.

NOTE The measure of the control pilot wire will take place on the EV supply equipment, socket outlet or plug, in case A and case B, and on the EV coupler in case C.

#### 5.4 Test list – Oscillator frequency and generator voltage test

[RA05-090] R2(state Cx), R3, and R2(state Dx) shall be at the nominal value for this test.

[RA05-100] The frequency shall be within  $\pm 0,5\%$  of 1 000 Hz at state B2 and C2 and D2 (if ventilation supported).

[RA05-110] The precision of measurements of voltages for this test shall be better than  $\pm 0,5\%$ .

[RA05-120] The voltage measured at the EV supply equipment output shall be as given in Table 10.

**Table 10 – Parameters of control pilot voltages**

	Minimum	Maximum
States A1, A2 / positive	11,4	12,6
States B1, B2 / positive	8,37	9,59
Negative	-12,6	-11,4

The internal resistor of the EV supply equipment (R1) value is calculated by the formula

$$R(\text{EV supply equipment}) = 2\,740 \times (V_{\text{state\_A}} - V_{\text{state\_B}}) / VR2$$

Where  $V_{\text{state\_A}}$  and  $V_{\text{state\_B}}$  are the two positive voltage values measured during the test of Table 10 and VR2 is the value of the positive voltage across R2 in state B.

[RA05-130] R(EV supply equipment) shall be  $1\,000\ \Omega \pm 3\%$ .

**5.5 Duty cycle test**

[RA05-140] Duty cycle should be tested at 5 % (if any), 10 % and the maximum current declared by the EV supply equipment manufacturer (in case the EV supply equipment cannot change the PWM it will be tested only at the default duty cycle).

[RA05-150] R2(state Cx), R3 and R2(state Dx) shall be at the nominal value for this test.

**5.6 Pulse wave shape test**

[RA05-160] The PWM pulse shape shall be within the values indicated in Table 11.

[RA05-170] R2(state Cx), R3 and R2(state Dx) shall be at the nominal value for this test.

**Table 11 – Test parameters of control pilot signals at the measure point according to Figure 8**

Parameter	Value	Unit
Maximum rise time (10 % to 90 %)	State B	10 μs
	State C	7 μs
	State D <sup>a</sup>	5 μs
Maximum fall time (90 % to 10 %)	States B, C, D <sup>a</sup>	13 μs
NOTE Signals are evaluated in the range of nominal resistance in the control pilot test circuit in Table 9.		
<sup>a</sup> In case ventilation is supported by the EV supply equipment.		

**5.7 Sequences diagnostic – normal charge cycle**

This test checks the AC supply and the timing in order to test the operation at the maximum and minimum allowed voltage levels.

These tests verify the operation of the pilot control over a complete cycle using the resistance values defined in Table 11.

[RA05-180] In case the EV supply equipment cannot change the PWM, there is no need to meet sequence 6.

All sequences need to be checked with the timing according to Table 6. A minimum delay of 20 s shall separate the sequences.

Figure 5 shows a normal operation cycle.

Testing the EV supply equipment by simulating an EV using the typical control pilot circuit 1.1 --> 3.1 --> 4 --> 7 --> 4 --> 6 --> 7 --> 8.1 --> 2.1.

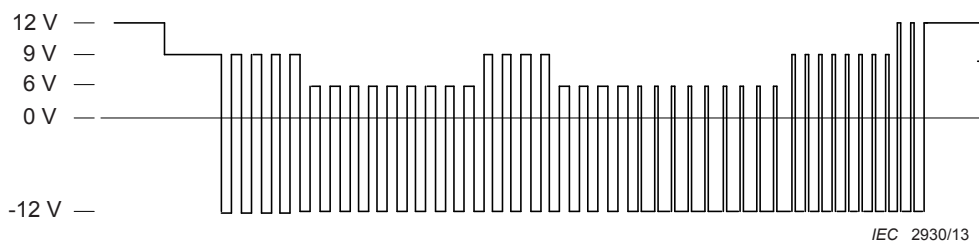

**Figure 5 – Normal operation cycle**

In case the EV supply equipment cannot change the PWM, sequence 6 is not needed.

[RA05-190] Unlocking of the coupler in the EV supply equipment, if any, needs to take place according to Table 5.

[RA05-200] Four complete standard charging cycles shall be performed using the resistor values indicated in Table 9. The EV supply equipment shall be deemed to have failed the test if the cycle is not completed.

**Table 12 – Normal charge cycle test**

	R3 (Ω)	R2 (Ω) State Cx	R2 (Ω) State Dx	HF voltage
Test 1	4 610	1 723	448	Not present
Test 2	4 610	1 723	448	Present
Test 3	1 870	909	140	Not present
Test 4	1 870	909	140	Present

Resistance tolerance is at least  $\pm 0,2\%$ .

HF voltage test is only required for EV supply equipment designed for digital communication. Lower voltages may apply for EV supply equipment not designed for digital communication systems.

NOTE HF voltage test is under consideration ( in ISO/IEC 15118-3<sup>2</sup>)

Testing the EV supply equipment by simulating an EV using the simplified control pilot circuit 1.2 --> 3.2 --> 5 --> 6 --> 2.2 is shown in Figure 6.

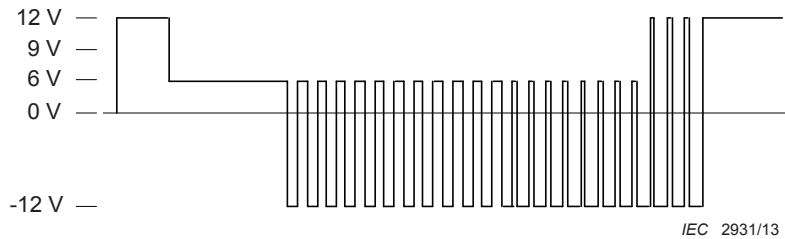

**Figure 6 – Simplified control pilot cycle**

Optional testing the EV supply equipment that support grid management by simulating an EV using the typical control pilot circuit is shown in Figure 7.

These tests are done using the nominal values of R2(state Cx), R3 and R2(state Dx) as given in Table 9.

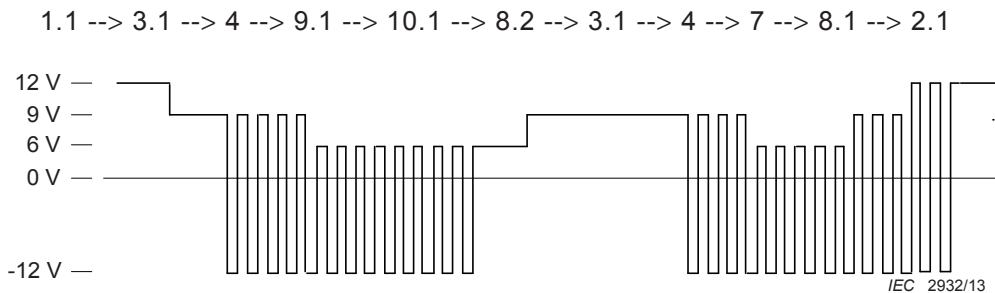

<sup>2</sup> Under consideration.

### Figure 7 – Optional charge cycle test

[RA05-210] During sequence 4, go to state E and unplug the power from the EV supply equipment.

NOTE Sequence 8.2 will take place just after sequence 10.1 with no waiting time.

#### 5.8 Open earth wire test

This test checks to determine whether the EV supply equipment is made as standard circuit.

[RA05-220] The EV supply equipment shall cut off the power in 100 ms when earth wire is opened (test is also a part of Table 13).

#### 5.9 Test of short circuit values of the voltage

[RA05-230] The EV supply equipment shall open the switching device when the short circuit voltage values are detected.

[RA05-240] The short circuit voltages are created by using intermediate resistance values.

[RA05-250] Test shall be initiated with R2 and R3 at the nominal value. When state C or D has been attained for at least 5 s, a supplementary resistance of 120  $\Omega$  is switched to connect between the pilot and the PE. According to Table 4 (Test is also a part of Table 13).the EV supply equipment shall open the supply switching device in max of 100 ms.

#### 5.10 Example of a test simulator of the vehicle (informative)

The Figure 8 gives an example of a possible test circuit that allows the simulation of the electric vehicle during charge. The switching of the resistor values (refer to Table 12) allows the extreme voltage values to be tested according to Table 9. The signal generator simulates the presence of an imposed high frequency data carrier.

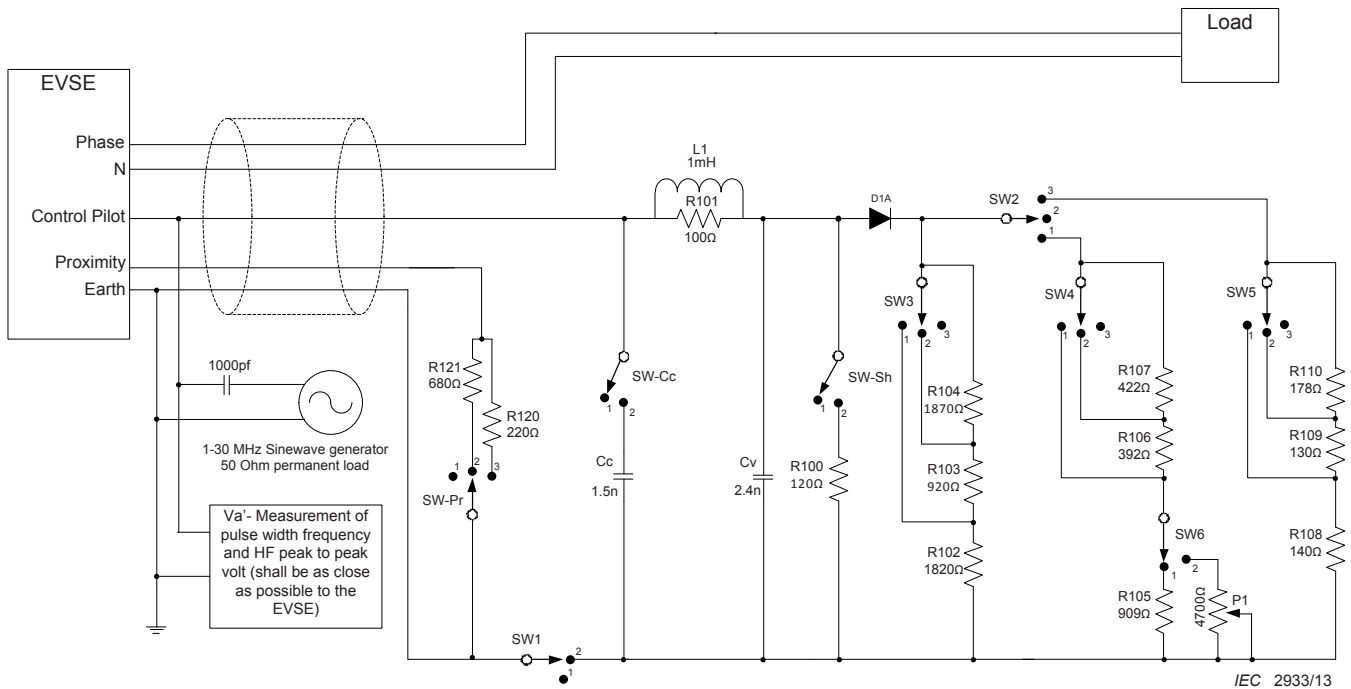

Charging cable length, for tests, is less than 3 m.

It is recommended to use metal coated resistors with 0,2 % tolerance or better.

Most of these resistances can be chosen from the E48 preferred resistance value of table, R102, R103 and R13 can be chosen from the E192 table and can also be constituted from several resistors from the E48 table.

High quality (gold plated contact) switches are recommended.

A fast turn off diode 1N4934 ( $I_{rms} = 1\text{ A}$ ,  $V_r > 100\text{ V}$ ,  $T_r = 200\text{ ns}$  or similar is recommended).

SW-Cc is for cable capacitance, open in case C.

**Figure 8 – Example of a test circuit (EV simulator)**

Table 13 defines the switch positions for the different operation conditions. It allows the simulation of the complete test cycles using the nominal resistances, or the tolerance limit values of the EV resistances. Out of bound values can also be created.

For tests at nominal values, SW1 and SW2 are used to switch between states A, B, C and D. Nominal values of the resistance are obtained with SW3, SW4, SW5, in position 2 and SW6 in position 1.



**Table 13 – Position of switches**

	State/switch		Pr	Sh	SW1	SW2	SW3	SW4	SW5	SW6
1	A	Unplugged	1	1	1	X	X	X	X	1
2	Earth fault	Open earth wire	X	1	1	X	X	X	X	1
3	E		2,3	2	2	2	X	X	X	1
4	B	Nominal values	2,3	1	2	2	2	X	X	1
5	C		2,3	1	2	1	2	2	X	1
6	D		2,3	1	2	3	2	X	2	1
7	B	Upper values	2,3	1	2	2	3	X	X	1
8	C		2,3	1	2	1	3	3	X	1
9	D		2,3	1	2	3	3	X	3	1
10	B	Lower values	2,3	1	2	2	1	X	X	1
11	C		2,3	1	2	1	1	1	X	1
12	D		2,3	1	2	3	1	X	1	1
13	B – C	Hysteresis	2,3	1	2	1	2	1	X	2
14	C – D		2,3	1	2	1	2	1	X	2
15	C – E		2,3	1	2	1	2	1	X	2
16	D – E		2,3	1	2	1	2	1	X	2

SW-Cc needs to be in position 1 in case C.

SW-Cc needs to be in position 2 in case A.

## 5.11 Optional hysteresis test

### 5.11.1 General

The test is done by modifying the value of R2 during the state C. The potentiometer P1 is used.

The test is done without the presence of a superimposed high frequency signal.

The voltage between the pilot wire terminals and the ground are monitored using a volt meter or similar.

It is not necessary to connect a load to the EV supply equipment during this test.

The initial value of the potentiometer P1 at the beginning of the test is set as indicated in Table 14

**Table 14 – Initial settings of the potentiometer at the beginning of each test**

Hysteresis between states	Initial resistance
B-C	1 300 Ω
C-D	1 300 Ω
C-E	1 300 Ω
D-E	270 Ω

### 5.11.2 Test sequence for hysteresis between states B and C

P1 is set to 1 300  $\Omega$ .

The charging system is brought to state C2 which results in the closing of the supply switching device.

The value of P1 is increased slowly so that the voltage on the pilot wire increases at less than 0,01 V/s, until the switching device opens. The voltage on the pilot wire at the instant of opening is noted.

The value of P1 is decreased slowly so that the voltage on the pilot wire increases at less than 0,01 V/s, until the switching device closes. The voltage on the pilot wire at the instant of closing is noted.

### 5.11.3 Test sequence for hysteresis between states C-E, D-E

P1 is set to 1 300  $\Omega$  for C-E and 270  $\Omega$  for D-E.

The charging system is brought to state C2 or D2 which results in the closing of the switching device.

The value of P1 is decreased slowly so that the voltage on the pilot wire decreases at less than 0,01 V/s, until the switching device opens. The voltage on the pilot wire at the instant of opening is noted.

The value of P1 is increased slowly so that the voltage on the pilot wire increases at less than 0,01V/s, until the switching device closes. The voltage on the pilot wire at the instant of closing is noted.

### 5.11.4 Test sequence for hysteresis between states C-D

P1 is set to 1 300  $\Omega$ .

The charging system is brought to state C2 which results in the closing of the switching device.

The value of P1 is decreased slowly so that the voltage on the pilot wire decreases at less than 0,01 V/s, until the ventilation switching device closes. The voltage on the pilot wire at the instant of closing is noted.

The value of P1 is increased slowly so that the voltage on the pilot wire increases at less than 0,01 V/s, until the ventilation switching device opens. The voltage on the pilot wire at the instant of closing is noted.

---



# British Standards Institution (BSI)

BSI is the national body responsible for preparing British Standards and other standards-related publications, information and services.

BSI is incorporated by Royal Charter. British Standards and other standardization products are published by BSI Standards Limited.

## About us

We bring together business, industry, government, consumers, innovators and others to shape their combined experience and expertise into standards-based solutions.

The knowledge embodied in our standards has been carefully assembled in a dependable format and refined through our open consultation process. Organizations of all sizes and across all sectors choose standards to help them achieve their goals.

## Information on standards

We can provide you with the knowledge that your organization needs to succeed. Find out more about British Standards by visiting our website at [bsigroup.com/standards](http://bsigroup.com/standards) or contacting our Customer Services team or Knowledge Centre.

## Buying standards

You can buy and download PDF versions of BSI publications, including British and adopted European and international standards, through our website at [bsigroup.com/shop](http://bsigroup.com/shop), where hard copies can also be purchased.

If you need international and foreign standards from other Standards Development Organizations, hard copies can be ordered from our Customer Services team.

## Subscriptions

Our range of subscription services are designed to make using standards easier for you. For further information on our subscription products go to [bsigroup.com/subscriptions](http://bsigroup.com/subscriptions).

With **British Standards Online (BSOL)** you'll have instant access to over 55,000 British and adopted European and international standards from your desktop. It's available 24/7 and is refreshed daily so you'll always be up to date.

You can keep in touch with standards developments and receive substantial discounts on the purchase price of standards, both in single copy and subscription format, by becoming a **BSI Subscribing Member**.

**PLUS** is an updating service exclusive to BSI Subscribing Members. You will automatically receive the latest hard copy of your standards when they're revised or replaced.

To find out more about becoming a BSI Subscribing Member and the benefits of membership, please visit [bsigroup.com/shop](http://bsigroup.com/shop).

With a **Multi-User Network Licence (MUNL)** you are able to host standards publications on your intranet. Licences can cover as few or as many users as you wish. With updates supplied as soon as they're available, you can be sure your documentation is current. For further information, email [bsmusales@bsigroup.com](mailto:bsmusales@bsigroup.com).

## BSI Group Headquarters

389 Chiswick High Road London W4 4AL UK

## Revisions

Our British Standards and other publications are updated by amendment or revision.

We continually improve the quality of our products and services to benefit your business. If you find an inaccuracy or ambiguity within a British Standard or other BSI publication please inform the Knowledge Centre.

## Copyright

All the data, software and documentation set out in all British Standards and other BSI publications are the property of and copyrighted by BSI, or some person or entity that owns copyright in the information used (such as the international standardization bodies) and has formally licensed such information to BSI for commercial publication and use. Except as permitted under the Copyright, Designs and Patents Act 1988 no extract may be reproduced, stored in a retrieval system or transmitted in any form or by any means – electronic, photocopying, recording or otherwise – without prior written permission from BSI. Details and advice can be obtained from the Copyright & Licensing Department.

## Useful Contacts:

### Customer Services

**Tel:** +44 845 086 9001

**Email (orders):** [orders@bsigroup.com](mailto:orders@bsigroup.com)

**Email (enquiries):** [cservices@bsigroup.com](mailto:cservices@bsigroup.com)

### Subscriptions

**Tel:** +44 845 086 9001

**Email:** [subscriptions@bsigroup.com](mailto:subscriptions@bsigroup.com)

### Knowledge Centre

**Tel:** +44 20 8996 7004

**Email:** [knowledgecentre@bsigroup.com](mailto:knowledgecentre@bsigroup.com)

### Copyright & Licensing

**Tel:** +44 20 8996 7070

**Email:** [copyright@bsigroup.com](mailto:copyright@bsigroup.com)



...making excellence a habit.™