



BSI Standards Publication

Direct current (DC) plugs and socket-outlets for information and communication technology (ICT) equipment installed in data centres and telecom central offices

Part 1: Plug and socket-outlet system for 2,6 kW

National foreword

This Published Document is the UK implementation of IEC/TS 62735-1:2015.

The UK participation in its preparation was entrusted to Technical Committee PEL/23, Electrical accessories.

A list of organizations represented on this committee can be obtained on request to its secretary.

This publication does not purport to include all the necessary provisions of a contract. Users are responsible for its correct application.

© The British Standards Institution 2015.

Published by BSI Standards Limited 2015

ISBN 978 0 580 75800 3

ICS 29.120.01; 29.120.30

Compliance with a British Standard cannot confer immunity from legal obligations.

This Published Document was published under the authority of the Standards Policy and Strategy Committee on 30 September 2015.

Amendments/corrigenda issued since publication

Date	Text affected
-------------	----------------------



TECHNICAL SPECIFICATION



**Direct current (DC) plugs and socket-outlets for information and communication technology (ICT) equipment installed in data centres and telecom central offices
Part 1: Plug and socket-outlet system for 2,6 kW**

INTERNATIONAL
ELECTROTECHNICAL
COMMISSION

ICS 29.120; 29.120.30

ISBN 978-2-8322-2869-2

Warning! Make sure that you obtained this publication from an authorized distributor.

CONTENTS

FOREWORD	6
1 Scope	8
2 Normative references	9
3 Terms and definitions	10
4 General requirements	14
5 General notes on tests	14
6 Ratings	16
7 Classification	16
7.1 Accessory classifications	16
7.1.1 Classification according to the method of connecting the cable	16
7.1.2 Classification according to the type of terminals	16
7.2 Socket-outlet classifications	16
7.2.1 Classification according to the degree of protection against electric shock	16
7.2.2 Classification according to the existence of shutters	16
7.2.3 Classification according to the method of application/mounting of the socket-outlet	16
7.2.4 Classification according to the method of installation	17
8 Marking	17
8.1 General	17
8.2 Symbols	17
8.3 Visibility of markings	18
8.4 Marking for plugs	18
8.5 Marking of terminals	18
8.6 Durability of marking	19
9 Checking of dimensions	19
10 Protection against electric shock	19
11 Provision for earthing	22
12 Terminals and terminations	23
12.1 General	23
12.2 Terminals with screw clamping for external copper conductors	24
12.3 Screwless terminals for external copper conductors	29
12.4 Flat quick-connect terminations	35
12.4.1 General	35
12.4.2 Constructional requirements	35
12.4.3 Electrical requirements	36
12.5 Permanent connections	36
13 Construction of socket-outlets	36
14 Construction of plugs	43
15 Interlocked socket-outlets	48
16 Resistance to ageing, protection provided by enclosures, and resistance to humidity	48
16.1 Resistance to ageing	48
16.2 Protection provided by enclosures	49
16.2.1 General	49

16.2.2	Protection against access to hazardous parts and against harmful effects due to ingress of solid foreign objects	49
16.3	Resistance to humidity	50
17	Insulation resistance and electric strength	51
18	Operation of earthing contacts	52
19	Temperature rise	53
20	Breaking capacity	56
21	Normal operation	57
22	Force necessary to withdraw the plug	58
22.1	General.....	58
22.2	Verification of the maximum withdrawal force for socket-outlets	59
22.3	Verification of the minimum withdrawal force.....	59
23	Flexible cables and their connection	60
24	Mechanical strength	63
25	Resistance to heat.....	72
26	Screws, current-carrying parts and connections.....	73
27	Creepage distances, clearances and distances through sealing compound.....	75
28	Resistance of insulating material to abnormal heat and to fire	77
29	Resistance to rusting	78
Annex A (normative) Safety-related routine tests for factory-wired accessories (protection against electric shock and correct polarity).....		107
A.1	General remarks	107
A.2	Polarized systems, “+” and “-” – correct connection.....	107
A.3	Earth continuity.....	108
A.4	Short-circuit/wrong connection and reduction of creepage distance and clearances between “+” and “-” to earth ()	108
Annex B (normative) Survey of specimens needed for tests		109
Annex C (informative) Alternative gripping tests.....		110
C.1	Gripping test C1.....	110
C.2	Gripping test C2.....	112
Annex D (normative) Standard sheets and gauges.....		114
D.1	Standard sheets.....	114
D.2	Gauges for checking the dimensions of the entry holes.....	118
Bibliography.....		121
Figure 1 – Examples of accessories.....		80
Figure 2 – Pillar terminals		81
Figure 3 – Screw terminals and stud terminals		82
Figure 4 – Saddle terminals		83
Figure 5 – Mantle terminals.....		84
Figure 6 – Example of thread-forming screw		84
Figure 7 – Example of thread-cutting screw		84
Figure 8 – Arrangement for compression test of 10.2 and 24.6		85
Figure 9 – Gauge for checking non-accessibility of live parts, through shutters		86
Figure 10 – Gauge for checking non-accessibility of live parts, through shutters, and of live parts of socket-outlets with increased protection.....		87

Figure 11 – Arrangement for checking damage to conductors	88
Figure 12 – Information for deflection test	89
Figure 13 – Device for checking the resistance to lateral strain	90
Figure 14 – Example of apparatus for breaking capacity and normal operation test.....	91
Figure 15 – Circuit diagram for breaking capacity and normal operation tests	92
Figure 16 – Apparatus for verification of maximum withdrawal force	92
Figure 17 – Apparatus for testing cord retention.....	93
Figure 18 – Apparatus for flexing test	94
Figure 19 – Sketches showing the application of the blows according to Table 20.....	95
Figure 20 – Apparatus for impact test at low temperature of 24.5	96
Figure 21 – Example of test arrangement to verify the fixation of pins in the body of the plug	97
Figure 22 – Arrangement for test on covers or cover-plates	97
Figure 23 – Gauge (thickness about 2 mm) for the verification of the outline of covers or cover-plates.....	98
Figure 24 – Examples of application of the gauge of Figure 23 on covers fixed without screws on a mounting surface or supporting surface	99
Figure 25 – Examples of application of the gauge of Figure 23 in accordance with the requirements of 24.16	100
Figure 26 – Gauge for verification of grooves, holes and reverse tapers	101
Figure 27 – Sketch showing the direction of application of the gauge of Figure 26	101
Figure 28 – Ball pressure test apparatus.....	101
Figure 29 – Apparatus for compression test for the verification of resistance to heat of 25.5	102
Figure 30 – Test procedures for normal operation (see Clause 21)	103
Figure 31 – Clamping unit for the temperature rise test of Clause 19	104
Figure 32 – The profile of the inrush current for the test of Clause 20	105
Figure 33 – Annex to Figure 32 with additional information on a possible circuit to produce the inrush current as given in Figure 32.....	105
Figure 34 – Circuit diagram for testing socket-outlets and plugs according to 18.2.....	106
Figure 35 – Possible test setup for the temperature rise test for Clauses 19 and 21	106
Figure C.1 – Reference plug for gripping test.....	111
Figure C.2 – Example of the test apparatus for plug gripping test	112
Figure D.1 – Standard sheet 1: 2,6 kW / 294 V to 400 V d.c. socket-outlet for class I equipment.....	115
Figure D.2 – Standard sheet 2: 2,6 kW / 294 V to 400 V d.c. plug for class I equipment.....	116
Figure D.3 – Standard sheet 3: positioning of the “+” and “–” pins/socket-contacts	117
Figure D.4 – Minimum gauges for checking the dimensions of the entry holes: C1	118
Figure D.5 – Maximum gauges for checking the dimensions of the entry holes: C2	118
Figure D.6 – Gauge for checking the first point of contact: C3.....	119
Figure D.7 – Gauges for checking the minimum withdrawal force (see 22.3)	119
Figure D.8 – Gauge for checking the maximum withdrawal force: C4max (see 22.2)	120
 Table 1 – Relationship between rated power and connectable nominal cross-sectional areas or American Wire Gauge (AWG) size of copper conductors	 24
Table 2 – Values for pull test for screw-type terminals	26

Table 3 – Composition of conductors	27
Table 4 – Tightening torques for the verification of the mechanical strength of screw-type terminals	28
Table 5 – Relationship between rated power and connectable cross-sectional areas or AWG size of copper conductors for screwless terminals	30
Table 6 – Value for pull test for screwless-type terminals.....	32
Table 7 – Values for flexing under mechanical load test for copper conductors	32
Table 8 – Test current for the verification of electrical and thermal stresses in normal use for screwless terminals.....	33
Table 9 – Nominal cross-sectional areas or AWG size of rigid copper conductors for deflection test of screwless terminals.....	34
Table 10 – Deflection test forces.....	35
Table 11 – Forces to be applied to tabs	36
Table 12 – Relationship between tab size and maximum current.....	36
Table 13 – Forces to be applied to covers, cover-plates or actuating members whose fixing is not dependent on screws	38
Table 14 – External cable dimension limits for surface-type socket-outlets	40
Table 15 – Nominal cross-sectional areas of copper conductors and test currents for the temperature rise test.....	54
Table 16 – Maximum and minimum withdrawal force for plugs and socket-outlets.....	60
Table 17 – External dimensions of flexible cables to be accommodated by cord anchorages.....	60
Table 18 – Torque test values for cord anchorages.....	61
Table 19 – Maximum dimensions of flexible cables to be accommodated in rewirable accessories	62
Table 20 – Height of fall for impact tests	65
Table 21 – Torque test values for glands	68
Table 22 – Resistance to heat of different types or parts of accessories	72
Table 23 – Creepage distances, clearances and distances through insulating sealing compound.....	76
Table B.1 – Number of specimens needed for the tests according to 5.5.....	109

INTERNATIONAL ELECTROTECHNICAL COMMISSION

**DIRECT CURRENT (DC) PLUGS AND SOCKET-OUTLETS FOR
INFORMATION AND COMMUNICATION TECHNOLOGY (ICT) EQUIPMENT
INSTALLED IN DATA CENTRES AND TELECOM CENTRAL OFFICES****Part 1: Plug and socket-outlet system for 2,6 kW**

FOREWORD

- 1) The International Electrotechnical Commission (IEC) is a worldwide organization for standardization comprising all national electrotechnical committees (IEC National Committees). The object of IEC is to promote international co-operation on all questions concerning standardization in the electrical and electronic fields. To this end and in addition to other activities, IEC publishes International Standards, Technical Specifications, Technical Reports, Publicly Available Specifications (PAS) and Guides (hereafter referred to as "IEC Publication(s)"). Their preparation is entrusted to technical committees; any IEC National Committee interested in the subject dealt with may participate in this preparatory work. International, governmental and non-governmental organizations liaising with the IEC also participate in this preparation. IEC collaborates closely with the International Organization for Standardization (ISO) in accordance with conditions determined by agreement between the two organizations.
- 2) The formal decisions or agreements of IEC on technical matters express, as nearly as possible, an international consensus of opinion on the relevant subjects since each technical committee has representation from all interested IEC National Committees.
- 3) IEC Publications have the form of recommendations for international use and are accepted by IEC National Committees in that sense. While all reasonable efforts are made to ensure that the technical content of IEC Publications is accurate, IEC cannot be held responsible for the way in which they are used or for any misinterpretation by any end user.
- 4) In order to promote international uniformity, IEC National Committees undertake to apply IEC Publications transparently to the maximum extent possible in their national and regional publications. Any divergence between any IEC Publication and the corresponding national or regional publication shall be clearly indicated in the latter.
- 5) IEC itself does not provide any attestation of conformity. Independent certification bodies provide conformity assessment services and, in some areas, access to IEC marks of conformity. IEC is not responsible for any services carried out by independent certification bodies.
- 6) All users should ensure that they have the latest edition of this publication.
- 7) No liability shall attach to IEC or its directors, employees, servants or agents including individual experts and members of its technical committees and IEC National Committees for any personal injury, property damage or other damage of any nature whatsoever, whether direct or indirect, or for costs (including legal fees) and expenses arising out of the publication, use of, or reliance upon, this IEC Publication or any other IEC Publications.
- 8) Attention is drawn to the Normative references cited in this publication. Use of the referenced publications is indispensable for the correct application of this publication.
- 9) Attention is drawn to the possibility that some of the elements of this IEC Publication may be the subject of patent rights. IEC shall not be held responsible for identifying any or all such patent rights.

The main task of IEC technical committees is to prepare International Standards. In exceptional circumstances, a technical committee may propose the publication of a Technical Specification when

- the required support cannot be obtained for the publication of an International Standard, despite repeated efforts, or
- the subject is still under technical development or where, for any other reason, there is the future but no immediate possibility of an agreement on an International Standard.

Technical Specifications are subject to review within three years of publication to decide whether they can be transformed into International Standards.

IEC TS 62735-1, which is a Technical Specification, has been prepared by IEC technical committee 23: Electrical accessories.

In this standard, the following print types are used:

- compliance statements: in *italic* type

The text of this Technical Specification is based on the following documents:

Enquiry draft	Report on voting
23/692/DTS	23/708A/RVC

Full information on the voting for the approval of this Technical Specification can be found in the report on voting indicated in the above table.

This publication has been drafted in accordance with the ISO/IEC Directives, Part 2.

A list of all parts in the IEC 62735 series, published under the general title *Direct current (DC) plugs and socket-outlets for information and communication technology (ICT) equipment installed in data centres and telecom central offices*, can be found on the IEC website.

The committee has decided that the contents of this publication will remain unchanged until the stability date indicated on the IEC website under "<http://webstore.iec.ch>" in the data related to the specific publication. At this date, the publication will be

- transformed into an International Standard,
- reconfirmed,
- withdrawn,
- replaced by a revised edition, or
- amended.

A bilingual version of this publication may be issued at a later date.

IMPORTANT – The 'colour inside' logo on the cover page of this publication indicates that it contains colours which are considered to be useful for the correct understanding of its contents. Users should therefore print this document using a colour printer.

DIRECT CURRENT (DC) PLUGS AND SOCKET-OUTLETS FOR INFORMATION AND COMMUNICATION TECHNOLOGY (ICT) EQUIPMENT INSTALLED IN DATA CENTRES AND TELECOM CENTRAL OFFICES

Part 1: Plug and socket-outlet system for 2,6 kW

1 Scope

This part of IEC 62735, which is a Technical Specification, applies to plugs and fixed socket-outlets for class I equipment with two active contacts plus an earthing contact, a rated power of 2,6 kW and a rated voltage range from 294 V to 400 V d.c. They are intended to power d.c. information and communication technology equipment only, products according to IEC 60950.

The accessories according to this part of IEC 62735 are intended to be used by ordinary persons in data centres only where the value of the d.c. voltage distribution system is defined as follows:

- 380 V with a tolerance of ± 20 V for installations with no backup battery or with a voltage regulation system;
- 380 V with a voltage range of 294 V to 400 V for installations with a backup battery where voltage regulation is not guaranteed;
- the voltage value between each live conductor and earth does not exceed 200 V d.c. during normal operation;
- there are two abnormal voltage ranges (duration below 10 min):
 - 260 V up to 294 V, and
 - above 400 V to 410 V.

The maximum current of the plug and the socket-outlet is

- 6,5 A when the voltage between live contacts is 400 V d.c.,
- 8,8 A when the voltage between live contacts is 294 V d.c.

and can rise up to 10 A when the voltage between live contacts decreases to 260 V d.c. for 10 min maximum.

The voltage between live conductors can fall down to 260 V d.c. when the voltage discharge value of the battery reaches the disconnecting level. The consequence is that the current increases accordingly.

The accessories according to this part of IEC 62735 do not require maintenance.

Plugs and socket-outlets covered by this part of IEC 62735 are intended for use in circuits where

- basic protection,
- an overcurrent protection (of 8,8 A or less for each socket-outlet or multiple socket-outlet),
- the fault protection (indirect contact protection), and
- additional protection

are already assured.

This part of IEC 62735 does not cover requirements for flush mounting boxes: however, it covers only those requirements for surface-type mounting boxes which are necessary for the tests on the socket-outlet.

NOTE 1 General requirements for mounting boxes are given in IEC 60670.

This part of IEC 62735 also applies to

- plugs incorporated in cord sets,
- plugs and socket-outlets incorporated in cord extension sets for data centres to be fixed to a wall or a rack,
- the cord extension set and multiple socket-outlets for data centres intended to be fixed to a wall or a rack, and
- socket-outlets which are a component of an assembly,

unless otherwise stated in the standard for the relevant assembly.

This part of IEC 62735 does not apply to

- single or multiple portable socket-outlets not fixed to a wall or a rack;
- plugs, socket-outlets and couplers for industrial purposes;
- plugs, socket-outlets and vehicle couplers for electric vehicles according to the IEC 61851 and IEC 62196 series;
- plugs and socket-outlets for household;
- appliance couplers;
- plugs, fixed and portable socket-outlets for extra-low voltage (ELV);

NOTE 2 ELV values are specified in IEC 60364-4-41.

- fixed socket-outlets combined with fuses, automatic switches, etc.

Socket-outlets with pilot lights are allowed provided that pilot lights comply with the relevant standard, if any.

Plugs and socket-outlets complying with this part of IEC 62735 are only suitable for use at ambient temperatures not normally exceeding +40 °C, but their average over a period of 24 h does not exceed +35 °C, with a lower limit of the ambient air temperature of –5 °C.

Socket-outlets complying with this part of IEC 62735 are only suitable for incorporation or mounting in equipment in such a way and in such a place that it is unlikely that the surrounding temperature exceeds 35 °C.

2 Normative references

The following documents, in whole or in part, are normatively referenced in this document and are indispensable for its application. For dated references, only the edition cited applies. For undated references, the latest edition of the referenced document (including any amendments) applies.

IEC 60050-151:2001, *International Electrotechnical Vocabulary – Part 151: Electrical and magnetic devices* (available at: www.electropedia.org)

IEC 60068-2-31, *Environmental testing – Part 2-31: Tests – Test Ec: Rough handling shocks, primarily for equipment-type specimens*

IEC 60227 (all parts), *Polyvinyl chloride insulated cables of rated voltages up to and including 450/750 V*

IEC 60245 (all parts), *Rubber insulated cables – Rated voltages up to and including 450/750 V*

IEC 60352-2, *Solderless connections – Part 2: Crimped connections – General requirements, test methods and practical guidance*

IEC 60423, *Conduit systems for cable management – Outside diameters of conduits for electrical installations and threads for conduits and fittings*

IEC 60512-12-1, *Connectors for electronic equipment – Tests and measurements – Part 12-1: Soldering tests – Test 12a: Solderability, wetting, solder bath method*

IEC 60512-12-2, *Connectors for electronic equipment – Tests and measurements – Part 12-2: Soldering tests – Test 12b: Solderability, wetting, soldering iron method*

IEC 60529, *Degrees of protection provided by enclosures (IP Code)*

IEC 60695-2-11, *Fire hazard testing – Part 2-11: Glowing/hot-wire based test methods – Glow-wire flammability test method for end-products (GWEPT)*

IEC 61032, *Protection of persons and equipment by enclosures – Probes for verification*

IEC 61210, *Connecting devices – Flat quick-connect terminations for electrical copper conductors – Safety requirements*

ISO 1456, *Metallic coatings – Electrodeposited coatings of nickel, nickel plus chromium, copper plus nickel and of copper plus nickel plus chromium*

3 Terms and definitions

For the purposes of this document, the terms and definitions given in IEC 60050-151 and the following apply.

NOTE 1 Where the terms "voltage" and "current" are used, they imply r.m.s. values, unless otherwise specified.

NOTE 2 Throughout this part of IEC 62735, the word "earthing" is used for "protective earthing".

NOTE 3 The term "accessory" is used as a general term covering plugs and socket-outlets; the term "portable accessory" covers plugs. Examples of the use of accessories are shown in Figure 1a.

3.1

plug

accessory having pins designed to engage with the contacts of a socket-outlet, also incorporating means for the electrical connection and mechanical retention of flexible cable

3.2

socket-outlet

accessory intended for frequent use by ordinary persons, having socket contacts designed to engage with the pins of a plug and having terminals, terminations or other means for the connection of cable and the like

Note 1 to entry: Throughout this part of IEC 62735, socket-outlets cover fixed socket-outlets, single and multiple socket-outlets for data centres to be fixed to a wall or a rack.

3.3

fixed socket-outlet

socket-outlet intended to be connected to fixed wiring

Note 1 to entry: An example is shown in Figure 1a.

3.4

single socket-outlet for data centres to be fixed to a wall or a rack

one socket-outlet for assemblies with or without cable

3.5

multiple socket-outlet for data centres to be fixed to a wall or a rack

combination of two or more socket-outlets for assemblies with or without cable

Note 1 to entry: An example is shown in Figure 1d.

3.6

socket-outlet for assemblies

socket-outlet intended to be built in, or fixed to assemblies

Note 1 to entry: Examples of assemblies are power strips, multiple socket-outlets to be fixed to a wall or a rack, power distribution units (PDUs), rectifier, d.c. power supply, and test equipment.

3.7

rewirable plug

plug so constructed that the flexible cable can be replaced

3.8

rewirable multiple socket-outlet for data centres intended to be fixed to a wall or a rack

multiple socket-outlet for data centres intended to be fixed to a wall or a rack so constructed that the flexible cable can be replaced

3.9

non-rewirable plug

plug so constructed that it forms a complete unit with the flexible cable after connection and assembly by the manufacturer of the accessory

Note 1 to entry: See also 14.1.

3.10

non-rewirable multiple socket-outlet for data centres intended to be fixed to a wall or a rack

multiple socket-outlet for data centres intended to be fixed to a wall or a rack so constructed that it forms a complete unit with the flexible cable after connection and assembly by the manufacturer of the accessory

Note 1 to entry: See also 14.1.

3.11

moulded-on plug

non-rewirable plug, the manufacture of which is completed by insulating material moulded around pre-assembled component parts and the terminations for the flexible cable or cord

[SOURCE: IEC 60050-442:1998, 442-01-14, modified – "accessory" has been replaced by "plug".]

3.12

mounting box

box intended for mounting in or on a wall, floor or ceiling, etc., for flush or surface application, intended for use with fixed socket-outlet(s)

3.13**cord extension set for data centres intended to be fixed to a wall or a rack**

assembly consisting of one flexible cable fitted with one plug and one single socket-outlet for equipment or multiple socket-outlet for data centres to be fixed to a wall or a rack

3.14**terminal**

insulated or non-insulated connecting device intended for reusable electrical connection of the external conductors

3.15**termination**

insulated or non-insulated connecting device intended for non-reusable electrical connection of the external conductors

3.16**clamping unit**

part or parts of a terminal necessary for the mechanical clamping and the electrical connection of the conductor(s) for test purposes

3.17**screw-type terminal**

terminal for the connection and subsequent disconnection of a conductor or the interconnection of two or more conductors, capable of being dismantled, the connection being made, directly or indirectly, by means of screws or nuts of any kind

3.18**pillar terminal**

screw-type terminal in which the conductor is inserted into a hole or cavity, where it is clamped under the end of the screw or screws

Note 1 to entry: The clamping pressure may be applied directly by the end of the screw or through an intermediate clamping member to which pressure is applied by the end of the screw.

Note 2 to entry: Examples of pillar terminals are shown in Figure 2.

3.19**screw terminal**

screw-type terminal in which the conductor is clamped under the head of the screw

Note 1 to entry: The clamping pressure may be applied directly to the head of a screw or through an intermediate part, such as a washer, clamping plate or anti-spread device.

Note 2 to entry: Examples of screw terminals are shown in Figure 3.

3.20**stud terminal**

screw-type terminal in which the conductor is clamped under a nut

Note 1 to entry: The clamping pressure may be applied directly by a suitably shaped nut or through an intermediate part, such as a washer, clamping plate or anti-spread device.

Note 2 to entry: Examples of stud terminals are shown in Figure 3.

3.21**saddle terminal**

screw-type terminal in which the conductor is clamped under a saddle by means of two or more screws or nuts

Note 1 to entry: Examples of saddle terminals are shown in Figure 4.

3.22**mantle terminal**

screw-type terminal in which the conductor is clamped against the base of a slot in a threaded stud by means of a nut

Note 1 to entry: The conductor is clamped against the base of the slot by a suitably shaped washer under the nut, by a central peg if the nut is a cap nut, or by an equally effective means for transmitting the pressure from the nut to the conductor within the slot.

Note 2 to entry: Examples of mantle terminals are shown in Figure 5.

3.23**screwless terminal**

connecting device for the connection and subsequent disconnection of a rigid (solid or stranded) or flexible conductor or the interconnection of two or more conductors, capable of being dismantled, the connection being made, directly or indirectly, by means of springs, parts of angled, eccentric or conical form, etc., without special preparation of the conductor concerned, other than removal of insulation

3.24**thread-forming screw**

screw having an uninterrupted thread, which by screwing in, forms a thread by displacing material

Note 1 to entry: An example of a thread-forming screw is shown in Figure 6.

3.25**thread-cutting screw**

screw having an interrupted thread, which by screwing in, forms a thread by removing material

Note 1 to entry: An example of a thread-cutting screw is shown in Figure 7.

3.26**rated power**

power assigned to the plug or socket-outlet

3.27**rated voltage range**

voltage range assigned to the plug or socket-outlet

3.28**shutter**

movable part incorporated into a socket-outlet arranged to shield at least the live socket-outlet contacts automatically when the plug is withdrawn

3.29**type test**

test of one or more devices made to a certain design to show that the design meets certain specifications

3.30**routine test**

test to which each individual device is subjected during and/or after manufacture to ascertain whether it complies with certain criteria

3.31**base**

part of the socket-outlet supporting the socket-contacts

3.32**live part**

conductor or conductive part intended to be energized in normal use, including a neutral conductor, but, by convention, not a PEN conductor

[SOURCE: IEC 60050-826: 826-12-08, modified – "normal operation" has been replaced by "normal use", "PEM or PEL conductor" has been deleted, and the note has been deleted.]

3.33**cable anchorage**

that part of an accessory which has the ability to limit the displacement of a fitted flexible cable against pull, push and turning forces

3.34**main part**

assembly consisting of the base and other parts

Note 1 to entry: This assembly is not intended to be dismantled at any time after manufacture.

3.35**prospective short-circuit current**

current that would flow in the circuit if the socket-outlet, the limitation device and the short circuit in the plug were replaced by links of negligible impedance without any other change in the circuit.

3.36**prospective let-through I^2t value**

value that would be let through by the current limiting device if the socket-outlet and the short circuit in the plug were replaced by links of negligible impedance

Note 1 to entry: The I^2t value may be limited by using an open wire fuse or other suitable devices.

3.37**stroke**

insertion or a withdrawal of the plug

4 General requirements

Accessories and boxes of surface mounting accessories shall be so designed and constructed that, in normal use, their performance is reliable and safety is achieved by reducing risk to a tolerable level, as defined in ISO/IEC Guide 51.

Compliance is checked by meeting all the relevant requirements and tests specified.

5 General notes on tests

5.1 *Tests shall be made to prove compliance with the requirements laid down in this part of IEC 62735, where applicable.*

Tests are made as follows:

- *type tests shall be made on representative specimens of each accessory;*
- *routine tests shall be made on each accessory manufactured according to this specification, where applicable.*

Subclauses 5.2 to 5.6 are applicable to type tests and 5.7 to routine tests.

5.2 *Unless otherwise specified, the specimens are tested as delivered and under normal conditions of use.*

Non-rewirable accessories are tested with the type and size of flexible cable as delivered; those not incorporated in a cord set or a cord extension set, or which are not a component of equipment, shall be provided for testing with at least 1 m of flexible cable.

Socket-outlets provided with a flexible cable are tested with the flexible cable as delivered.

Socket-outlets which require a box to complete their enclosure are tested with their boxes.

5.3 *Tests shall be carried out according to voltage described in test with a maximum tolerance of ± 5 %. In case of d.c. test voltage from rectifying a.c. voltage and not battery, ripple voltage shall not exceed 5 %.*

5.4 *Unless otherwise specified, the tests are carried out in the order of the clauses, at an ambient temperature between $+15$ °C and $+35$ °C.*

In case of doubt, the tests are made at an ambient temperature of $(+20 \pm 5)$ °C.

Plugs and socket-outlets are tested separately.

5.5 *Three specimens are subjected to all the relevant tests.*

For the tests of 12.3.11, additional specimens of socket-outlets having in total at least five screwless terminals are required.

For the tests of 12.3.12, three additional specimens of socket-outlets are necessary; in each specimen one clamping unit is tested.

For the tests of 13.19, three additional specimens of separate membranes, or of accessories incorporating membranes, are required.

For the tests of Clauses 20 and 21, additional specimens may be necessary (see Clauses 20 and 21, and Figure 30).

For non-rewirable accessories, six additional specimens are required for the test of 23.2 and 23.4.

For the test of 24.9, three additional specimens are required.

For the test of Clause 28, three additional specimens may be necessary.

NOTE Annex B specifies the number of specimens needed for the tests.

5.6 *The specimens are submitted to all the relevant tests and the requirements are satisfied if all the tests are met.*

If one specimen does not satisfy a test due to an assembly or a manufacturing fault, that test and any preceding one which may have influenced the results of the test shall be repeated, and also the tests which follow shall be made in the required sequence on another full set of specimens, all of which shall comply with the requirements.

NOTE The applicant can submit, together with a number of specimens specified in 5.5, the additional set of specimens which might be required, if one specimen fails. The testing station will then, without further request, test

the additional specimens and will only reject them if a further failure occurs. If the additional set of specimens is not submitted at the same time, the failure of one specimen will entail rejection.

5.7 *Routine tests are specified in Annex A.*

6 Ratings

Accessories shall have a rated power of 2,6 kW at any voltage within the rated voltage range of 294 V to 400 V.

7 Classification

7.1 Accessory classifications

7.1.1 Classification according to the method of connecting the cable

Accessories are classified according to the method of connecting the cable as follows:

- rewirable;
- non-rewirable.

7.1.2 Classification according to the type of terminals

Accessories are classified according to the type of terminals as follows:

- accessories with screw-type terminals;
- accessories with screwless terminals for rigid conductors only;
- accessories with screwless terminals for rigid and flexible conductors.

7.2 Socket-outlet classifications

7.2.1 Classification according to the degree of protection against electric shock

Socket-outlets are classified according to the degree of protection against electric shock when mounted as for normal use:

- a) socket-outlets with normal protection (see 10.2), or
- b) socket-outlets with increased protection (see 10.7).

NOTE Socket-outlets with increased protection can be socket-outlets with or without shutters.

7.2.2 Classification according to the existence of shutters

Socket-outlets are classified according to the existence of shutters:

- a) socket-outlets without shutters, or
- b) socket-outlets with shutters (see 10.5).

NOTE In the following countries, socket-outlets without shutters are not allowed: Belgium, France, and Italy.

7.2.3 Classification according to the method of application/mounting of the socket-outlet

Socket-outlets are classified according to the method of application/mounting of the socket-outlet:

- a) surface type;
- b) flush type;
- c) semi flush type;

- d) panel type;
- e) floor recessed type;
- f) assembly type;
- g) rail-mounting type.

7.2.4 Classification according to the method of installation

Socket-outlets are classified according to the method of installation, as a consequence of the design:

- a) fixed socket-outlets where the cover or cover-plate can be removed without displacement of the conductors (design A); or
- b) fixed socket-outlets where the cover or cover-plate cannot be removed without displacement of the conductors (design B).

If a fixed socket-outlet has a base (main part) which cannot be separated from the cover or cover-plate, and requires a supplementary plate to meet the specification which can be removed without displacement of the conductors, it is considered to be of design A, provided the supplementary plate meets the requirements specified for covers and cover-plates.

8 Marking

8.1 General

Accessories shall be marked with the following:

- a) rated power in watts;
- b) rated voltage range in volts;
- c) symbol for d.c.;
- d) manufacturer's or responsible vendor's name, trademark or identification mark;
- e) type reference which may be a catalogue number;
- f) capacitive electronic load.



In addition, socket-outlets with screwless terminals shall be marked with the following:

- g) an appropriate marking indicating the length of insulation to be removed before the insertion of the conductor into the screwless terminal;
- h) an indication of the suitability to accept rigid conductors only, for those socket-outlets having this restriction.

The additional markings may be put on the socket-outlet, on the packaging unit and/or given in an instruction sheet which accompanies the socket-outlet.

8.2 Symbols

When symbols are used, they shall be as follows:

Watt	W
Volt	V
Direct current	
positive	+
negative	-
Protective earth (IEC 60417-5019 (2006-08))	

For screwless terminals: suitability to accept rigid conductors only..... r

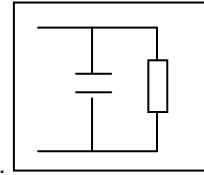

The type of load

NOTE 1 Details of construction of symbols are given in IEC 60417.

For the marking with rated power and rated voltage range the figures may be used alone. These figures shall be placed on one line separated by an oblique line or the figure for rated power shall be placed above the figure for rated voltage range, separated by a horizontal line.

The marking for the nature of the supply shall be placed next to the marking for rated power and rated voltage.

NOTE 2 The marking for voltage, power and nature of supply can be, for example, as follows:

2600 W / 294–400 V

8.3 Visibility of markings

For fixed socket-outlets, the following marking shall be placed on the main part:

- rated power, rated voltage range, and symbol for d.c.;
- either the name, trademark or identification mark of the manufacturer or of the responsible vendor;
- length of insulation to be removed before the insertion of the conductor into the screwless terminal, if any;
- the type reference, which may be a catalogue number or the series reference;
- the type of load.

Parts such as cover plates, which are necessary for safety purposes and are intended to be sold separately, shall be marked with the manufacturer's or responsible vendor's name, trademark or identification mark and type reference.

8.4 Marking for plugs

For plugs the marking specified in 8.1, other than the type reference, shall be easily discernible when the accessory is wired and assembled.

The type reference of rewirable plug may be marked on the inside of the enclosure or cover.

8.5 Marking of terminals

Terminals of the live parts shall be marked with their polarity.

Earthing terminals for the connection of the protective conductor shall be marked by the symbol

These markings shall not be placed on screws or any other easily removable parts.

"Easily removable parts" are those parts which can be removed during the normal installation of the socket-outlet or the assembly of the plug.

Terminations in non-rewirable accessories need not be marked.

NOTE In the following countries, the earthing terminal is coloured green, and a terminal intended to be connected to a neutral conductor is coloured white or grey: Canada, USA.

Terminals provided for the connection of conductors not forming part of the main function of the socket-outlets shall be clearly identified unless their purpose is self-evident, or indicated in a wiring diagram which shall be fixed to the accessory.

The indication of such terminals may be achieved by

- their being marked with graphical symbols according to IEC 60417 or colours and/or alphanumeric system, or
- their being marked with their physical dimensions or relative location.

Leads of neon or indicator lamps are not considered to be conductors in the context of 8.5.

8.6 Durability of marking

Marking shall be durable and easily legible.

Compliance is checked by inspection and by the following test.

The marking is rubbed by hand for 15 s with a piece of cloth soaked with water and again for 15 s with a piece of cloth soaked with petroleum spirit.

Marking made by impression, moulding, pressing or engraving is not subjected to this test.

The petroleum spirit should consist of a solvent hexane with an aromatic content of maximum 0,1 % volume fraction, a kauributanol value of approximately 29, an initial boiling point of approximately 65 °C, a dry point of approximately 69 °C and a density of approximately 0,68 g/cm³.

9 Checking of dimensions

Plugs and socket-outlets shall comply with the standard sheets and corresponding gauges in Annex D.

Compliance is checked by inspection to the dimensional requirements as given in the standard sheets and the rigidity test of the skirt as given in Clause 24.

10 Protection against electric shock

10.1 Socket lacquer, enamel and sprayed insulating coatings shall not be used as insulating material.

10.2 Socket-outlets shall be so designed and constructed that when they are mounted and wired as for normal use, live parts are not accessible, even after removal of parts which can be removed without the use of a tool.

Live parts of plugs shall not be accessible when the plug is in partial or complete engagement with a socket-outlet.

Compliance is checked by inspection and, if necessary, by the following test.

The test is made on the specimen mounted as for normal use and fitted with conductors of the smallest nominal cross-sectional area, the test being then repeated using conductors of the largest nominal cross-sectional area, specified in Table 1.

The standard test finger, test probe B of IEC 61032, is applied in every possible position, an electrical indicator with a voltage between 40 V and 50 V being used to show contact with the relevant parts.

For plugs, the test finger is applied when the plug is in partial and complete engagement with a socket-outlet.

For accessories where the use of thermoplastic or elastomeric material is likely to influence the requirements, one additional test is made but at an ambient temperature of $(35 \pm 2) ^\circ\text{C}$, the accessories being at this temperature.

During this additional test the accessories are subjected for 1 min to a force of 75 N, applied through the tip of a straight unjointed test finger, test probe 11 of IEC 61032. This finger with an electrical indicator as described above is applied to all places where yielding of insulating material could impair the safety of the accessory, but is not applied to membranes or the like and is applied to thin-walled knock-outs but with a force of 10 N.

During this test, accessories, with their associated mounting means, shall not deform to such an extent that those dimensions shown in the relevant standard sheets which ensure safety are unduly altered and no live parts shall be accessible.

Each specimen of plug or socket-outlet for data centres intended to be fixed to a wall or a rack is then pressed between two flat surfaces with a force of 150 N for 5 min, as shown in Figure 8. The specimen is checked 15 min after removal from the test apparatus, and shall not show such deformation as would result in undue alteration of those dimensions shown in the relevant standard sheets which ensure safety.

10.3 Parts which are accessible when the accessory is wired and mounted as for normal use, with the exception of small screws and the like, isolated from live parts, for fixing bases and covers or cover-plates of socket-outlets, shall be made of insulating material; however, the covers or cover-plates of fixed socket-outlets and accessible parts of plugs and socket-outlets for data centres intended to be fixed to a wall or a rack may be made of metal if the requirements given in 10.3.1 or 10.3.2 are fulfilled.

10.3.1 Metal covers or cover-plates are protected by supplementary insulation made by insulating linings or insulating barriers fixed to covers or cover-plates or to the body of accessories in such a way that the insulating linings or insulating barriers cannot be removed without being permanently damaged, or so designed that they cannot be replaced in an incorrect position and that, if they are omitted, the accessories are rendered inoperable or manifestly incomplete and there is no risk of accidental contact between live parts and metal covers or cover-plates, for example through their fixing screws, even if a conductor should come away from its terminal, and if precautions are taken in order to prevent creepage distances or clearances becoming less than the values specified in Table 23.

In the case of single-pole insertion, the requirement given in 10.4 applies.

Compliance is checked by inspection.

The above linings or barriers shall comply with the tests of Clauses 17 and 27.

10.3.2 Metal covers or cover-plates shall be automatically connected, through a low-resistance connection, to the earth during fixing of the cover or the cover-plate itself.

The creepage distances and the clearances between the live pins of a plug when fully inserted and the earthed metal cover of a socket-outlet shall comply with items 2 and 7 of Table 23, respectively. In addition, in the case of single-pole insertion, the requirement given in 10.4 applies.

Fixing screws or other means are allowed.

Compliance is checked by inspection and by the tests of 11.4.

10.4 It shall not be possible to make contact between a pin of a plug and a live socket-contact of a socket-outlet while any other pin is accessible.

Compliance is checked by inspection to the dimensional requirements as given in the standard sheets.

10.5 Shuttered socket-outlets shall, in addition, be so constructed that live parts are not accessible without a plug in engagement, with the gauges shown in Figures 9 and 10.

The gauges shall be applied to the entry holes corresponding to the live contacts only and shall not touch live parts.

The means for achieving this shall be such that they cannot easily be operated by anything other than a plug and shall not depend upon parts which are liable to be lost.

An electrical indicator with a voltage between 40 V and 50 V included is used to show contact with the relevant part.

Compliance is checked by inspection and for socket-outlets with a plug completely withdrawn by applying the above gauges as follows.

The gauge according to Figure 9 is applied to the entry holes corresponding to the live contacts with a force of 20 N.

The gauge is applied to the shutters in the most unfavourable position, successively in three directions, to the same place for approximately 5 s in each of the three directions.

During each application, the gauge shall not be rotated and it shall be applied in such a way that the 20 N force is maintained. When moving the gauge from one direction to the next, no force is applied but the gauge shall not be withdrawn.

A steel gauge according to Figure 10 is then applied with a force of 1 N and in three directions, for approximately 5 s in each direction, with independent movements, withdrawing the gauge after each movement.

For socket-outlets with enclosures or bodies of thermoplastic material, the test is made at an ambient temperature of (35 ± 2) °C, both the socket-outlets and the gauge being at this temperature.

10.6 The earthing contact of a socket-outlet shall be so designed that it cannot be deformed by the insertion of a plug to such an extent that safety is impaired.

Compliance is checked by the following test.

The socket-outlet is placed in such a position that the socket-contacts are in a vertical position.

A test plug, corresponding to the type of socket-outlet, is inserted into the socket-outlet with a force of 150 N which is applied for 1 min.

After this test, the socket-outlet shall still comply with the requirements of Clause 9.

10.7 Socket-outlets with increased protection shall be so constructed that, when mounted and wired as in normal use, live parts shall not be accessible.

Compliance is checked by inspection and by applying with a test wire of 1,0 mm diameter (see Figure 10) a force of 1 N on all accessible surfaces in the most unfavourable conditions without a plug inserted.

For socket-outlets with enclosures or bodies of thermoplastic material, the test is made at an ambient temperature of (35 ± 2) °C, both the socket-outlets and the gauge being at this temperature.

During this test, it shall not be possible to touch live parts with the gauge.

An electrical indicator as described in 10.2 shall be used.

11 Provision for earthing

11.1 Accessories shall be so constructed that when inserting the plug the earth connection is made before the current-carrying contacts of the plug become live.

When withdrawing the plug, the current-carrying pins shall separate before the earth connection is broken.

Compliance is checked by inspection to the dimensional requirements as given in the standard sheets.

11.2 Earthing terminals of rewirable accessories shall comply with the appropriate requirements of Clause 12.

They shall be of the same size as the corresponding terminals for the supply conductors.

Earthing terminals of rewirable accessories with earthing contact shall be internal.

Earthing terminals of fixed socket-outlets shall be fixed to the base or to a part reliably fixed to the base.

Earthing contacts of fixed socket-outlets shall be fixed to the base or to the cover. If fixed to the cover, they shall be automatically and reliably connected to the earthing terminal when the cover is put in place, the contact pieces being silver-plated or having a protection no less resistant to corrosion and abrasion.

This connection shall be ensured under all conditions which can occur in normal use, including loosening of cover-fixing screws, careless mounting of the cover, etc.

Except as mentioned above, parts of the earthing circuit shall be in one piece or shall be reliably connected together by riveting, welding, or the like.

The requirement regarding the connection between an earthing contact fixed to a cover and an earthing terminal may be met by the use of a solid pin and a resilient socket-contact.

For the purpose of the requirements of 11.2, screws are not considered as parts of contact pieces.

When considering the reliability of the connection between parts of the earthing circuit, the effect of possible corrosion is taken into account.

11.3 Accessible metal parts of fixed socket-outlets with earthing contact, which may become live in the event of an insulation fault, shall be permanently and reliably connected to the earthing terminal.

This requirement does not apply to the metal cover-plates mentioned in 10.3.1.

For the purpose of this requirement, small screws and the like – electrically separated from live parts – for fixing bases, covers, or cover-plates, are not considered as accessible parts which may become live in the event of an insulation fault.

For fixed socket-outlets with metal enclosures having an external earthing terminal, this terminal shall be interconnected with the terminal fixed to the base.

11.4 The connection between the earthing terminal and accessible metal parts to be connected to it shall be of low resistance.

Compliance is checked by the following test.

A current of $(25 \pm 0,25)$ A, derived from an a.c. source having a no-load voltage not exceeding 12 V, is passed between the earthing terminal and each of the accessible metal parts in turn.

The voltage drop between the earthing terminal and the accessible metal part is measured, and the resistance calculated from the current and this voltage drop.

In no case shall the resistance exceed 0,05 Ω .

Ensure that the contact resistance between the tip of the measuring probe and the metal part under test does not influence the test results.

12 Terminals and terminations

12.1 General

12.1.1 All the tests on terminals, with the exception of the test of 12.3.11 and 12.3.12 shall be made after the tests of Clause 16.

12.1.2 Rewirable socket-outlets except socket-outlets for assemblies shall be provided with screw-type terminals or with screwless terminals.

Socket-outlets for assemblies shall be provided with screw-type terminals, screwless terminals, male tabs of flat quick-connect terminations or other means.

Rewirable plugs shall be provided with terminals with screw clamping.

If pre-soldered flexible conductors are used, in screw-type terminals the pre-soldered area shall be outside the clamp area when connected as for normal use.

The means for clamping the conductors in the terminals shall not serve to fix any other component, although they may hold the terminals in place or prevent them from turning.

12.1.3 Non-rewirable accessories shall be provided with soldered, welded, crimped or equally effective permanent connections (termination); screwed or snap-on connections shall not be used.

Connections made by crimping a pre-soldered flexible conductor are not permitted, unless the soldered area is outside the crimping area.

12.1.4 *Compliance with the requirements of 12.1.1, 12.1.2, 12.1.3 is checked by inspection and by the tests of 12.2, 12.3, 12.4 or 12.5, as applicable.*

12.2 Terminals with screw clamping for external copper conductors

12.2.1 Accessories shall be provided with terminals which allow the proper connection of copper conductors having nominal cross-sectional areas as shown in Table 1.

Table 1 – Relationship between rated power and connectable nominal cross-sectional areas or American Wire Gauge (AWG) size of copper conductors

Power and type of accessory	Rigid (solid or stranded) copper conductors		Flexible copper conductors	
	Nominal cross-sectional area or AWG size	Corresponding diameter of the largest conductor mm	Nominal cross-sectional area or AWG size ^a	Corresponding diameter of the largest conductor mm
2,6 kW 2P+ 	1,5 mm ² or AWG 16	1,7 or 1,30	From 0,75 mm ² up to 1,5 mm ² inclusive or From AWG 18 up to AWG 16 inclusive	1,8 or 1,34
^a The nominal cross-sectional area of the conductors of socket-outlets for data centres intended to be fixed to a wall or a rack is 1,5 mm ² or AWG 16.				

The conductor space shall be at least that specified in Figures 2, 3, 4 or 5.

Compliance is checked by inspection, by measurement and by fitting conductors of the smallest and largest nominal cross-sectional areas specified.

12.2.2 Terminals with screw clamping shall allow the conductor to be connected without special preparation.

Compliance is checked by inspection.

The term "special preparation" covers soldering of the wires of the conductor, use of cable lugs, formation of eyelets, etc., but not the reshaping of the conductor before its introduction into the terminal or the twisting of a flexible conductor to consolidate the end.

12.2.3 Terminals with screw clamping shall have adequate mechanical strength.

Screws and nuts for clamping the conductors shall have a metric ISO thread or a thread comparable in pitch and mechanical strength.

Screws shall not be of metal which is soft or liable to creep, such as zinc or aluminium.

Compliance is checked by inspection and by the tests of 12.2.6 and 12.2.8.

SI, BA, and UN threads are considered to be comparable in pitch and mechanical strength to metric ISO thread.

12.2.4 Terminals with screw clamping shall be resistant to corrosion.

Terminals, the body of which is made of copper or copper alloy as specified in 26.5, are considered as complying with this requirement.

12.2.5 Terminals with screw clamping shall be so designed and constructed that they clamp the conductor(s) without undue damage to the conductor(s).

Compliance is checked by the following test.

The terminal is placed in the test apparatus according to Figure 11 and fitted with rigid, solid, stranded and/or flexible conductor(s) according to Table 1, first with the smallest and then with the largest nominal cross-sectional area, the clamping screw(s) or nut(s) being tightened with the torque according to Table 4.

Where rigid stranded conductors do not exist, the test may be made with rigid solid conductors only. In this case, there is no need for further tests.

The length of the test conductor shall be 75 mm longer than the height (H) specified in Table 7.

The end of the conductor is passed through an appropriate bushing in a plate positioned at a height (H) below the equipment, as given in Table 7. The bushing is positioned in a horizontal plane such that its centre line describes a circle of 75 mm diameter, concentric with the centre of the clamping unit in the horizontal plane; the platen is then rotated at a rate of (10 ± 2) r/min.

The distance between the mouth of the clamping unit and the upper surface of the bushing shall be within ± 15 mm of the height specified in Table 7. The bushing may be lubricated to prevent binding, twisting, or rotation of the insulated conductor.

A mass as specified in Table 7 is suspended from the end of the conductor. The duration of the test is approximately 15 min.

During the test, the conductor shall neither slip out of the clamping unit nor break near the clamping unit, nor shall the conductor be damaged in such a way as to render it unfit for further use.

The test shall be repeated with rigid solid conductors where they exist, if the first test has been made with rigid stranded conductors.

12.2.6 Terminals with screw clamping shall be so designed that they clamp the conductor reliably between metal surfaces.

Compliance is checked by inspection and by the following test.

The terminals are fitted with rigid solid or stranded conductors for socket-outlets and flexible conductors for plugs using conductors of the smallest and largest nominal cross-sectional

area specified in Table 1, the terminal screws being tightened with a torque equal to two-thirds of the torque shown in the appropriate column of Table 4.

If the screw has a hexagonal head with a slot, the torque applied is equal to two-thirds of the torque shown in column 3 of Table 4.

Each conductor is then subjected to a pull as specified in Table 2, applied in a smooth and continuous motion for 1 min in the direction of the axis of the conductor space.

Table 2 – Values for pull test for screw-type terminals

Nominal cross-sectional area or AWG size of conductors accepted by the terminal	Pull N
Above 0,75 mm ² up to 1,5 mm ² inclusive or AWG 18 to AWG 16	40

If the clamp is provided for two or three conductors, the appropriate pull is applied consecutively to each conductor.

During the test, the conductor shall not move noticeably in the terminal.

12.2.7 Terminals with screw clamping shall be so designed or placed that neither a rigid solid conductor nor a wire of a stranded conductor can slip out while the clamping screws or nuts are tightened.

Compliance is checked by the following test.

The terminals are fitted with conductors having the largest nominal cross-sectional area specified in Table 1.

The terminals of fixed socket-outlets are checked both with rigid solid conductors and with rigid stranded conductors.

The terminals of plugs and socket-outlets for data centres intended to be fixed to a wall or a rack are checked with flexible conductors.

Terminals intended for the looping-in of two or three conductors are checked, being fitted with the permissible number of conductors.

The terminals are fitted with conductors having the composition shown in Table 3.

Table 3 – Composition of conductors

Nominal cross-sectional area or AWG size	Number of wires (n) and nominal diameter of conductors (d) $n \times d^a$		
	Flexible conductor	Rigid solid conductor	Rigid stranded conductor
0,75 mm ² ^b	20 × 0,20	–	–
1,0 mm ²	32 × 0,20	1 × 1,13	7 × 0,42
1,5 mm ²	30 × 0,25	1 × 1,38	7 × 0,52
18 AWG	16 × 0,255	1 × 1,03	–
16 AWG	26 × 0,255	1 × 1,30	–

^a values of d in millimetres.
^b This diameter is only for plugs.

Before insertion into the clamping means of the terminal, wires of rigid (solid or stranded) conductors are straightened; rigid stranded conductors may, in addition, be twisted to restore them approximately to their original shape and flexible conductors are twisted in one direction so that there is a uniform twist of one complete turn in a length of approximately 20 mm.

The conductor is inserted into the clamping means of the terminal for the minimum distance prescribed or, where no distance is prescribed, until it just projects from the far side of the terminal and in the position most likely to allow the wire to escape.

The clamping screw is then tightened with a torque equal to two-thirds of the torque shown in the appropriate column of Table 4.

For flexible conductors the test is repeated with a new conductor which is twisted as before, but in the opposite direction.

After the test, no wire of the conductors shall have escaped from the clamping unit, thus reducing creepage distances and clearances to values lower than those indicated in Table 23.

12.2.8 Terminals with screw clamping shall be so fixed or located within the accessory that, when the clamping screws or nuts are tightened or loosened, the terminals shall not work loose from their fixing to accessories.

These requirements do not imply that the terminals are designed so that their rotation or displacement is prevented; but any movement is sufficiently limited so as to prevent non-compliance with this part of IEC 62735.

The use of sealing compound or resin is considered to be sufficient for preventing a terminal from working loose, provided that

- the sealing compound or resin is not subject to stress during normal use, and
- the effectiveness of the sealing compound or resin is not impaired by temperatures attained by the terminal under the most unfavourable conditions specified in this part of IEC 62735.

Compliance is checked by inspection, by measurement and by the following test.

A rigid solid copper conductor of the largest nominal cross-sectional area specified in Table 1 is placed in the terminal.

Where rigid solid conductors do not exist, the test may be made with rigid stranded conductors.

Before insertion into the clamping means of the terminal, wires of rigid (solid or stranded) conductors are straightened; rigid stranded conductors may, in addition, be twisted to restore them approximately to their original shape.

The conductor is inserted into the clamping means of the terminal for the minimum distance prescribed or, where no distance is prescribed, until it just projects from the far side of the terminal and in the position most likely to allow the wire to escape.

Screws and nuts are tightened and loosened five times by means of a suitable test screwdriver or spanner, the torque applied when tightening being equal to the torque shown in the appropriate column of Table 4 or in the table of the appropriate Figures 2, 3 or 4, whichever is the greater.

The conductor is moved each time the screw or nut is loosened.

Where a screw has a hexagonal head with a slot, only the test with the screwdriver is made with the torque values given in column 3.

Table 4 – Tightening torques for the verification of the mechanical strength of screw-type terminals

Nominal diameter of thread mm	Equivalent UNC screw size	Torque N·m		
		1 ^a	2 ^b	3 ^c
Up to and including 2,8	#3	0,2	0,4	–
Over 2,8 up to and including 3,0	#4	0,25	0,5	–
Over 3,0 up to and including 3,2	–	0,3	0,6	–
Over 3,2 up to and including 3,6	#6	0,4	0,8	–
Over 3,6 up to and including 4,1	–	0,7	1,2	1,2
Over 4,1 up to and including 4,7	#8	0,8	1,8	1,2
Over 4,7 up to and including 5,3	–	0,8	2,0	1,4

^a Column 1 applies to screws without a head if the screw, when tightened, does not protrude from the hole and to other screws which cannot be tightened by means of a screwdriver with a blade wider than the diameter of the screw.

^b Column 2 applies to other screws which are tightened by means of a screwdriver and to screws and nuts which are tightened by means other than a screwdriver.

^c Column 3 applies to nuts of mantle terminals which are tightened by means of a screwdriver.

During the test, terminals shall not work loose and there shall be no damage, such as breakage of screws or damage to heads, slots (rendering the use of the appropriate screwdriver impossible), threads, washers or stirrups that will impair the further use of the terminal.

For mantle terminals the specified nominal diameter is that of the slotted stud.

The shape of the blade of the test screwdriver shall suit the head of the screw to be tested.

The screws and nuts shall be tightened in a smooth and continuous motion.

12.2.9 Clamping screws or nuts of earthing terminals with screw clamping shall be adequately locked against accidental loosening and it shall not be possible to loosen them without the aid of a tool.

Compliance is checked by manual test.

The terminal designs shown in Figures 2, 3, 4 and 5 provide sufficient resiliency to comply with this requirement; for other designs, special provisions, such as the use of an adequate resilient part which is not likely to be removed inadvertently, may be necessary.

12.2.10 Earthing terminals with screw clamping shall be such that there is no risk of corrosion resulting from contact between these parts and the copper of the earthing conductor, or any other metal that is in contact with these parts.

The body of the earthing terminal shall be of brass or other metal no less resistant to corrosion, unless it is a part of the metal frame or enclosure, in which case the screw or nut shall be of brass or other metal no less resistant to corrosion.

If the body of the earthing terminal is a part of a frame or enclosure of aluminium alloy, precautions shall be taken to avoid the risk of corrosion resulting from contact between copper and aluminium or its alloys.

Compliance is checked by inspection.

Screws or nuts of plated steel withstanding the corrosion test are considered to be of a metal no less resistant to corrosion than brass.

12.2.11 For pillar terminals, the distance between the clamping screw and the end of the conductor, when fully inserted, shall be at least that specified in Figure 2.

The minimum distance between the clamping screw and the end of the conductor applies only to pillar terminals where the conductor cannot pass right through.

For mantle terminals, the distance between the fixed part and the end of the conductor, when fully inserted, shall be at least that specified in Figure 5.

Compliance is checked by measurement, after a solid conductor of the largest nominal cross-sectional area specified in Table 1 has been fully inserted and fully clamped.

12.3 Screwless terminals for external copper conductors

12.3.1 Screwless terminals may be of the type suitable for rigid copper conductors only or of the type suitable for both rigid and flexible copper conductors.

For the latter type the tests are carried out with rigid conductors first and then repeated with flexible conductors.

Subclause 12.3.1 is not applicable to socket-outlets provided with the following:

- screwless terminals requiring the fixing of special devices to the conductors before clamping them in the screwless terminal, for example flat push-on connectors;
- screwless terminals requiring twisting of the conductors, for example those with twisted joints;
- screwless terminals providing direct contact to the conductors by means of edges or points penetrating the insulation.

12.3.2 Screwless terminals shall be provided with two clamping units, each allowing the proper connection of rigid or of rigid and flexible copper conductors having nominal cross-sectional areas as shown in Table 7.

Table 5 – Relationship between rated power and connectable cross-sectional areas or AWG size of copper conductors for screwless terminals

Rated power kW	Conductors		
	Nominal cross-sectional areas or AWG size	Diameter of largest rigid conductor mm	Diameter of largest flexible conductor mm
2,6	1,5 mm ²	1,7	1,8
	or AWG 16	1,30	1,34

When two conductors have to be connected, each conductor shall be introduced in a separate independent clamping unit (not necessarily in separate holes).

Compliance is checked by inspection and by fitting conductors of the smallest and largest nominal cross-sectional areas specified.

12.3.3 Screwless terminals shall allow the conductor to be connected without special preparation.

Compliance is checked by inspection.

The term "special preparation" covers soldering of the wires of the conductor, use of terminal ends, etc., but not the reshaping of the conductor before introduction into the terminal or the twisting of a flexible conductor to consolidate the end.

12.3.4 Parts of screwless terminals mainly intended to carry current shall be of materials as specified in 26.5.

Compliance is checked by inspection and by chemical analysis.

Springs, resilient units, clamping plates and the like are not considered as parts mainly intended to carry current.

12.3.5 Screwless terminals shall be so designed that they clamp the specified conductors with sufficient contact pressure and without undue damage to the conductor.

The conductor shall be clamped between metal surfaces.

Conductors are considered to be unduly damaged if they show appreciably deep or sharp indentations.

Compliance is checked by inspection and by the tests of 12.3.10.

12.3.6 It shall be clear how the connection and disconnection of the conductors is to be made.

The intended disconnection of a conductor shall require an operation, other than a pull on the conductor, so that it can be made manually with or without the help of a general purpose tool.

It shall not be possible to confuse the opening intended for the use of a tool to assist the connection or disconnection with the opening intended for the conductor.

Compliance is checked by inspection and by the tests of 12.3.10.

12.3.7 Screwless terminals which are intended to be used for the interconnection of two or more conductors shall be so designed that

- during the insertion, the operation of the clamping means of one of the conductors is independent of the operation of that of the other conductor(s);
- during the disconnection, the conductors can be disconnected either at the same time or separately;
- each conductor is introduced in a separate clamping unit (not necessarily in separate holes);
- it is possible to clamp securely any number of conductors up to the maximum as designed.

Compliance is checked by inspection and by manual tests with the appropriate conductors (in number and size).

12.3.8 Screwless terminals of fixed socket-outlets shall be designed so that adequate insertion of the conductor is obvious and over-insertion is prevented if further insertion is liable to reduce the creepage distances and/or clearances required in Table 23, or to influence the operation of the socket-outlet.

Compliance is checked by inspection and by the tests of 12.3.10.

12.3.9 Screwless terminals shall be properly fixed to the socket-outlet.

They shall not work loose when the conductors are connected or disconnected during installation.

Compliance is checked by inspection and by the tests of 12.3.10.

Covering with sealing compound without other means of locking is not sufficient. Self-hardening resins may, however, be used to fix terminals which are not subject to mechanical stress in normal use.

12.3.10 Screwless terminals shall withstand the mechanical stresses occurring in normal use.

Compliance is checked by the following tests which are carried out with uninsulated conductors on one screwless terminal of each specimen, using a new specimen for each test.

The test is carried out with solid rigid copper conductors, first with conductors having the largest nominal cross-sectional area, and then with conductors having the smallest nominal cross-sectional area specified in Table 5.

Conductors are connected and disconnected five times, new conductors being used each time, except for the fifth time, when the conductors used for the fourth connection are clamped at the same place. For each connection, the conductors are either pushed as far as possible into the terminal or are inserted so that adequate connection is obvious.

After each connection, the conductor is subjected to a pull of the value shown in Table 6; the pull is applied in a smooth and continuous motion, for 1 min, in the direction of the longitudinal axis of the conductor space.

Table 6 – Value for pull test for screwless-type terminals

Rated power kW	Pull N
2,6	40

During the application of the pull, the conductor shall not come out of the screwless terminal.

The test is then repeated with rigid stranded copper conductors having the largest and smallest nominal cross-sectional areas specified in 12.3.2; these conductors are, however, connected and disconnected only once.

Screwless terminals intended for both rigid and flexible conductors shall also be tested with flexible conductors, making five connections and disconnections.

For fixed socket-outlets with screwless terminals, each conductor is subjected for 15 min to a circular motion with (10 ± 2) r/min using apparatus, an example of which is shown in Figure 11. During this test, a mass as specified in Table 7 is suspended from the end of the conductor.

Table 7 – Values for flexing under mechanical load test for copper conductors

Nominal cross-sectional area of conductor or AWG size	Diameter of bushing hole ^a mm	Height, <i>H</i> mm	Mass for conductor kg
1,5 mm ² , 16 AWG	6,5	260	0,4

^a If the bushing-hole diameter is not large enough to accommodate the conductor without binding, a bushing having the next larger hole size may be used.

During the test, the conductors shall not move noticeably in the clamping unit.

After these tests, neither the terminals nor the clamping means shall have worked loose and the conductors shall show no deterioration impairing their further use.

12.3.11 Screwless terminals shall withstand the electrical and thermal stresses occurring in normal use.

Compliance is checked by the following tests a) and b), which are carried out on five screwless terminals of socket-outlets which have not been used for any other test.

Both tests are carried out with new copper conductors.

a) *The test is carried out loading the screwless terminals for 1 h with a direct current as specified in Table 8 and connecting rigid solid conductors 1 m long having the nominal cross-sectional area as specified in Table 8.*

The test is carried out on each clamping unit.

Table 8 – Test current for the verification of electrical and thermal stresses in normal use for screwless terminals

Rated power	Test current	Nominal cross-sectional area of the conductor or AWG size
kW	A	
2,6	17,5	1,5 mm ² or AWG 16

During the test the current is not passed through the socket-outlet, but only through the terminals.

Immediately after this period, the voltage drop across each screwless terminal is measured with the maximum current at lowest voltage flowing.

In no case shall the voltage drop exceed 15 mV.

The measurements are made across each screwless terminal and as near as possible to the place of contact.

If the back connection of the terminal is not accessible, the specimens may be adequately prepared by the manufacturer; ensure that the behaviour of the terminals is not affected.

Ensure that, during the period of the test, including the measurements, the conductors and the measurement devices are not moved noticeably.

- b) *The screwless terminals already subjected to the determination of the voltage drop specified in the previous test a) are tested as follows.*

During the test, a current equal to the test current value given in Table 8 is passed.

The whole test arrangement, including the conductors, shall not be moved until the measurements of the voltage drop have been completed.

The terminals are subjected to 192 temperature cycles, each cycle having a duration of approximately 1 h and carried out as follows:

- the current flows for approximately 30 min;*
- for a further period of approximately 30 min no current flows.*

The voltage drop in each screwless terminal is determined as prescribed for the test of a) after every 24 temperature cycles and after the 192 temperature cycles have been completed.

In no case shall the voltage drop exceed 22,5 mV or twice the value measured after the twenty-fourth cycle, whichever is the smaller.

After this test an inspection by normal or corrected vision without additional magnification shall show no changes evidently impairing further use such as cracks, deformations or the like.

In addition, the mechanical strength test according to 12.3.10 is repeated and all specimens shall withstand this test.

12.3.12 Screwless terminals shall be so designed that the connected rigid solid conductor remains clamped, even when it has been deflected during normal installation, for example, during mounting in a box, and the deflecting stress is transferred to the clamping unit.

Compliance is checked by the following test which is made on three specimens of socket-outlets which have not been used for any other test.

The test apparatus, the principle of which is shown in Figure 12a, shall be so constructed that

- a specified conductor properly inserted into a terminal is allowed to be deflected in any of the 12 directions differing from each other by 30°, with a tolerance of ± 5° with respect to each direction; and*
- the starting point can be varied by 10° and 20° from the original point.*

A reference direction need not be specified.

The deflection of the conductor from its straight position to the testing positions shall be effected by means of a suitable device, applying a specified force to the conductor at a certain distance from the terminal.

The deflecting device shall be so designed that

- the force is applied in a direction perpendicular to the undeflected conductor;*
- the deflection is attained without rotation or displacement of the conductor within the clamping unit;*
- the force remains applied while the prescribed voltage drop measurement is made.*

Provisions shall be made so that the voltage drop across the clamping unit under test can be measured when the conductor is connected, as shown for example in Figure 12b.

The specimen is mounted on the fixed part of the test apparatus in such a way that the specified conductor inserted into the clamping unit under test can be freely deflected.

If necessary, the inserted conductor may be permanently bent around obstacles so that these do not influence the results of the test.

In some cases, with the exception of the case of guidance for the conductor, it may be advisable to remove those parts of the specimens which do not allow the deflection of the conductor corresponding to the force to be applied.

To avoid oxidation, the insulation shall be removed from the conductor immediately before starting the test.

A clamping unit is fitted as for normal use with a rigid solid copper conductor having the smallest nominal cross-sectional area specified in Table 9 and is submitted to a first test sequence. The same clamping unit is submitted to a second test sequence using the conductor having the largest nominal cross-sectional area, unless the first test sequence has failed.

The force for deflecting the conductor is specified in Table 10, the distance of 100 mm being measured from the extremity of the terminal, including the guidance, if any, for the conductor, to the point of application of the force to the conductor.

The test is made with continuous current (i.e. the current is not switched on and off during the test); a suitable power supply should be used and an appropriate resistance should be inserted in the circuit so that the current variations are kept within $\pm 5\%$ during the test.

Table 9 – Nominal cross-sectional areas or AWG size of rigid copper conductors for deflection test of screwless terminals

Rated power of the socket-outlet kW	Nominal cross-sectional area or AWG size of the test conductor	
	First test sequence	Second test sequence
2,6	1,5 mm ² or AWG 16	1,5 mm ² or AWG 16

Table 10 – Deflection test forces

Nominal cross-sectional area or AWG size of the test conductor	Force for deflecting the test conductor ^a N
1,5 mm ² or AWG 16	0,5
^a The force is chosen so that it stresses the conductor close to the limit of elasticity.	

A test current equal to the maximum current at lowest voltage of the socket-outlet is passed through the clamping unit under test. A force according to Table 10 is applied to the test conductor inserted in the clamping unit under test in one of the 12 directions shown in Figure 12a and the voltage drop across this clamping unit is measured. The force is then removed.

The force is then applied successively on each one of the remaining 11 directions shown in Figure 12a, following the same test procedure.

If, for any of the 12 test directions, the voltage drop is greater than 25 mV, the force is maintained in this direction until the voltage drop is reduced to a value below 25 mV, but for not more than 1 min. After the voltage drop has reached a value below 25 mV, the force is maintained in the same direction for a further period of 30 s during which period the voltage drop shall not have increased.

The other two specimens of socket-outlets of the set are tested following the same test procedure, but moving the 12 directions of the force so that they differ by approximately 10° for each specimen.

If one specimen has failed at one of the directions of application of the test force, the tests are repeated on another set of specimens, all of which shall comply with this new series of tests.

12.4 Flat quick-connect terminations

12.4.1 General

Male tabs and female connectors to be used for test purposes shall comply with IEC 61210.

12.4.2 Constructional requirements

12.4.2.1 Male tabs shall be of nominal sizes:

- 4,8 mm × 0,8 mm or
- 6,3 mm × 0,8 mm,

as detailed in IEC 61210.

Compliance is checked by measuring three specimens, all of which shall comply with the dimensional requirements of IEC 61210.

Round dimple indents, rectangular dimple indents, hole indents or provisions for nonreversible flat quick-connect terminations, if any, shall also comply with IEC 61210.

12.4.2.2 Male tabs shall be made from copper or copper alloy (bare or tin plated).

Materials or coatings other than those specified may be used, provided that their electrical and mechanical characteristics are no less reliable, particularly with regard to resistance to corrosion, stability of contact resistance and mechanical strength.

12.4.2.3 Male tabs shall have adequate strength to allow the application and removal of female connectors without damage to the socket-outlet so as to impair compliance with this part of IEC 62735.

Compliance is checked by applying, in a smooth and continuous motion, axial forces equal to those shown in Table 11.

No displacement or damage shall occur which might impair further use.

Table 11 – Forces to be applied to tabs

Male tab size (nominal) mm	Push N	Pull N
4,8 × 0,8	60	50
6,3 × 0,8	80	70

12.4.2.4 Male tabs shall be adequately spaced to allow the connection of the appropriate female connectors.

Compliance is checked by applying an appropriate female connector to each male tab; during this operation, no strain or distortion shall occur to any of the tabs or to their adjacent parts, nor shall the creepage distance or clearance be reduced below those specified in Clause 27.

12.4.3 Electrical requirements

Male tab sizes shall be related to the maximum current at the lowest voltage of the socket-outlet as shown in Table 12.

Table 12 – Relationship between tab size and maximum current

Male tab size (nominal) mm	Maximum current at lowest voltage A
4,8 × 0,8	10
6,3 × 0,8	10

12.5 Permanent connections

Crimped connections shall be tested according to IEC 60352-2.

Soldered connections shall be tested according to IEC 60512-12-1 or IEC 60512-12-2, as appropriate.

13 Construction of socket-outlets

13.1 Socket contact assemblies shall have sufficient resilience to ensure adequate contact pressure on plug pins.

Compliance is checked by inspection and the tests of Clauses 9, 21 and 22.

13.2 Socket contacts of socket-outlets shall be resistant to corrosion and abrasion.

Compliance is checked by inspection and the tests of 26.5.

13.3 Insulating linings, barriers and the like shall have adequate mechanical strength.

Compliance is checked by inspection and by the tests of Clause 24.

13.4 Socket-outlets shall be so constructed as to permit

- easy introduction and connection of the conductors in the terminals;
- easy fixing of the base to a wall or in a mounting box or in an assembly;
- correct positioning of the conductors;
- adequate space between the underside of the base and the surface on which the base is mounted or between the sides of the base and the enclosure (cover or box) so that, after installation of the socket-outlet, the insulation of the conductors is not necessarily pressed against live parts of different polarity.

This requirement does not imply that the metal parts of the terminal are necessarily protected by insulating barriers or insulating shoulders to avoid contact, due to incorrect installation of the terminal metal parts, with the insulation of the conductor.

For surface type socket-outlets to be mounted on a mounting plate, a wiring channel may be needed to comply with this requirement.

In addition, socket-outlets classified as design A shall permit easy positioning and removal of the cover or cover-plate, without displacing the conductors.

Compliance is checked by inspection and by an installation test with conductors of the largest nominal cross-sectional area specified in Table 1.

13.5 Socket-outlets shall be so designed that full engagement of associated plugs is not prevented by any projection from their engagement face.

Compliance is checked by determining that the gap between the engagement face of the socket-outlet and the plug does not exceed 1 mm when the plug is inserted into the socket-outlet as far as it will go.

13.6 If covers are provided with bushings for the entry holes for the pins, it shall not be possible to remove them from the outside or for them to become detached inadvertently from the inside when the cover is removed.

Compliance is checked by inspection and, if necessary, by manual test.

13.7 Covers, cover-plates or parts of them which are intended to ensure protection against electric shock shall be held in place at two or more points by effective fixings.

Covers, cover-plates or parts of them may be fixed by means of a single fixing (for example, by a screw), provided that they are positioned by another means (for example, by a shoulder).

The fixings of covers or cover-plates shall be captive.

The use of tight-fitting washers of cardboard or the like is deemed to be an adequate method for securing screws intended to be captive.

Non-earthed metal parts separated from live parts in such a way that creepage distances and clearances have the values specified in Table 23, are not considered as accessible if the requirements of 13.7 are met.

Where the fixings of covers or cover-plates of socket-outlets of design A serve to fix the base, there shall be means to maintain the base in position, even after removal of the covers or cover-plates.

Compliance is checked by the tests of 13.7.1, 13.7.2 or 13.7.3.

13.7.1 *For covers or cover-plates whose fixings are of the screw-type:*

by inspection only.

13.7.2 *For covers or cover-plates whose fixing is not dependent on screws and whose removal is obtained by applying a force in a direction approximately perpendicular to the mounting/supporting surface (see Table 13):*

- *when their removal may give access, with the standard test finger, to live parts:
by the tests of 24.13;*
- *when their removal may give access, with the standard test finger, to non-earthed metal parts separated from live parts in such a way that creepage distances and clearances have the values shown in Table 23:
by the tests of 24.14;*
- *when their removal may give access, with the standard test finger, only to*
 - *parts of insulating material, or*
 - *earthed metal parts, or*
 - *metal parts separated from live parts in such a way that creepage distances and clearances have twice the values shown in Table 23, or*
 - *live parts of SELV circuits not greater than 25 V a.c.:
by the tests of 24.15.*

Table 13 – Forces to be applied to covers, cover-plates or actuating members whose fixing is not dependent on screws

Accessibility with the standard test finger after removal of covers, cover-plates or parts of them	Tests according to ...	Force to be applied N			
		Number of socket-outlets complying with 24.16 and 24.17 which shall not come off		Number of socket-outlets not complying with 24.16 and 24.17 which shall not come off	
		shall not come off	shall come off	shall not come off	shall come off
To live parts	24.13	40	120	80	120
To non-earthed metal parts separated from live parts by creepage distances and clearances according to Table 23	24.14	10	120	20	120
To insulating parts, earthed metal parts, live parts of SELV ≤ 25 V a.c. or metal parts separated from live parts by creepage distances twice those according to Table 23	24.15	10	120	10	120

13.7.3 *For covers or cover-plates the fixing of which is not dependent on screws and whose removal is obtained by using a tool, in accordance with the manufacturer's instructions given in an instruction sheet or in other documentation:*

by the same tests of 13.7.2 except that the covers or cover-plates or parts of them need not come off when applying a force not exceeding 120 N in directions perpendicular to the mounting/supporting surface.

13.8 Surface-type socket-outlets shall be so constructed that, when they are fixed and wired as for normal use, there are no free openings in their enclosures other than the entry openings for the pins of the plug or other openings for contacts: locking devices, etc.

Small gaps between enclosures or boxes and conduits, cables, or earthing contacts (if any), or between enclosures or boxes and grommets or membranes and knockouts are ignored.

Compliance is checked by inspection and by an installation test using a cable having conductors of the smallest nominal cross-sectional area specified in Table 14.

13.9 Screws or other means for mounting the socket-outlet on a surface in a box or enclosure shall be easily accessible from the front. These means shall not serve any other fixing purpose.

13.10 Multiple socket-outlets with a common base shall be provided with fixed links for the interconnection of the contacts in parallel. The fixing of these links shall be independent of the connection of the supply wires.

NOTE Multiple socket-outlets cover multiple fixed socket-outlets and multiple socket-outlets for data centres to be fixed to a wall or a rack.

13.11 Multiple socket-outlets, comprising separate bases, shall be so designed that the correct position of each base is ensured. The fixing of each base shall be independent of the fixing of the combination to the mounting surface.

Compliance with the requirements of 13.9 to 13.11 is checked by inspection.

NOTE Multiple socket-outlets cover multiple fixed socket-outlets and multiple socket-outlet for data centres to be fixed to a wall or a rack.

13.12 The mounting plate of surface-type socket-outlets shall have adequate mechanical strength.

Compliance is checked by inspection after the test of 13.4 and by the test of 24.4.

13.13 Socket-outlets shall withstand the lateral strain imposed by equipment likely to be introduced into them.

Compliance is checked by means of the device shown in Figure 13.

Each specimen is mounted on a vertical surface with the plane through the socket-contacts horizontal. The device is then fully engaged and a mass hung on it such that the force exerted is 5 N.

The device is removed after 1 min and the socket-outlet is turned through 90° on the mounting surface. The test is made four times, the socket-outlet being turned through 90° after each engagement.

During the test the device shall not become disengaged from the socket-outlet.

After the tests, the socket-outlets shall not show any damage which impairs safety as required by Clause 4; in particular, they shall comply with the requirements of Clause 22.

13.14 Socket-outlets shall not be an integral part of lampholders.

Compliance is checked by inspection.

13.15 All contacts shall be locked against rotation.

When the product is ready for the wiring, it shall not be possible to remove any contact without the use of a tool.

It shall not be possible to remove a contact without the aid of a tool, after removal of an enclosure requiring the use of a tool.

Compliance is checked by inspection and by manual test.

13.16 Metal strips of the earthing circuit shall have no burrs which might damage the insulation of the supply conductors.

Compliance is checked by inspection.

13.17 Socket-outlets to be installed in a box shall be so designed that the conductor ends can be prepared after the box is mounted in position, but before the socket-outlet is fitted in the box.

Compliance is checked by inspection.

13.18 Inlet openings shall allow the introduction of the conduit or the sheath of the cable so as to afford complete mechanical protection.

Surface-type socket-outlets shall be so constructed that the conduit or sheath of the cable can enter at least 1 mm into the enclosure.

In surface-type socket-outlets the inlet opening for conduit entries, or at least two of them if there are more than one, shall be capable of accepting conduit sizes of 16, 20, 25 or 32 according to IEC 60423 or a combination of at least two of any of these sizes.

In surface-type socket-outlets, the inlet opening for cable entries will preferably be capable of accepting cables having the dimensions specified in Table 14 or be as specified by the manufacturer.

Socket-outlets for assemblies shall be so designed that the assembling of their component parts is not affected by the method of fixing the socket-outlet to the assembly

The method of fixing shall be such that the socket-outlet cannot turn and cannot be detached from the assembly without the aid of a tool.

Table 14 – External cable dimension limits for surface-type socket-outlets

Rated power kW	Nominal cross-sectional area or AWG size of conductors	Number of conductors	Limits of external dimensions of cables mm	
			Minimum	Maximum
2,6	1,5 mm ² or AWG 16	3	6,3	10.4

Compliance is checked by inspection and by measurement.

Inlet openings of adequate size may also be obtained by the use of knock-outs or of suitable insertion pieces.

13.19 Membranes (grommets) in inlet openings shall be reliably fixed and shall not be displaced by the mechanical and thermal stresses occurring in normal use.

Compliance is checked by inspection and by the following test.

Membranes are tested when assembled in the accessory.

First the accessories are fitted with membranes which have been subjected to the treatment specified in 16.1.

The accessories are then placed for 2 h in a heating cabinet as described in 16.1, the temperature being maintained at (40 ± 2) °C.

Immediately after this period, a force of 30 N is applied for 5 s to various parts of the membranes by means of the tip of a straight unjointed test finger (test probe 11 of IEC 61032).

During these tests, the membranes shall not deform to such an extent that live parts become accessible.

For membranes likely to be subjected to an axial pull in normal use, an axial pull of 30 N is applied for 5 s.

During this test, the membranes shall not become detached.

The test is then repeated with membranes which have not been subjected to any treatment.

After the tests of 13.19 the membranes shall show no harmful deformation, cracks or similar damage which would lead to non-compliance with this part of IEC 62735.

13.20 For rewirable single and multiple socket-outlets for data centres intended to be fixed to a wall or a rack, the following apply.

- It shall be clear how the relief from strain and the prevention of twisting is intended to be effected.
- The cord anchorage, or at least part of it, shall be integral with or securely fixed to one of the component parts of the plug or socket-outlet for data centres to be fixed to a wall or a rack.
- Makeshift methods, such as tying the flexible cable in a knot or tying the ends with string, shall not be used.
- The cord anchorage shall be suitable for the different types of flexible cable which may be connected to it.
- Screws, if any, which have to be operated to clamp the flexible cable, shall not serve to fix any other component. This does not exclude a cover serving to retain the flexible cable in position in the cord anchorage provided the cable remains in place in the accessory when the cover is removed.
- Cord anchorages shall be of insulating material or be provided with an insulating lining fixed to the metal parts.
- Metal parts of cord anchorages, including clamping screws, shall be insulated from the earthing circuit.

13.21 The enclosures of rewirable single and multiple socket-outlets for data centres intended to be fixed to a wall or a rack shall completely enclose the terminals and the ends of flexible cable.

The construction shall be such that the conductors can be properly connected and that, when the accessory is wired and assembled as for normal use, it is unlikely that

- pressing the cores together causes damage to the conductor insulation likely to result in a breakdown of the insulation;
- a core, whose conductor is connected to a live terminal, is pressed against accessible metal parts;
- a core, whose conductor is connected to an earthing terminal, is pressed against live parts.

13.22 Rewirable single and multiple socket-outlets for data centres intended to be fixed to a wall or a rack shall be designed with ample space for slack in the earthing conductor so that, if the strain relief is rendered inoperative, the connection of the earthing conductor is subjected to strain after the connections of the current-carrying conductors and, in case of excessive stress, the earthing conductor will break after the current-carrying conductors.

Compliance is checked by the following test.

The current-carrying conductors of a flexible cable are connected to the accessory in such a way that they are led from the strain relief to the corresponding terminals along the shortest possible path. Following which, the core of the earthing conductor is led to its terminal and cut off at a distance 8 mm longer than necessary when using the shortest possible path for its correct connection.

The earthing conductor is then connected to the terminal. It shall then be possible to house the loop, which is formed by the earthing conductor owing to its surplus length when the accessory is assembled correctly.

In non-rewirable non-moulded-on accessories with earthing contact, the length of the conductors between the terminations and the cord anchorage shall be adjusted in such a way that the current-carrying conductors will be stressed before the earthing conductor, if the flexible cable slips in its anchorage.

Compliance is checked by inspection.

13.23 Terminals of rewirable single and multiple socket-outlets for data centres intended to be fixed to a wall or a rack shall be located or shielded in such a way that loose wires from a conductor in the accessory will not present a risk of electric shock.

Compliance is checked by the following test.

A 6 mm length of insulation is removed from the end of a flexible conductor, having the minimum required nominal cross-sectional area specified in Table 1. One wire of the flexible conductor is left free and the remaining wires are fully inserted into and clamped in the terminal as for normal use.

The free wire is bent, without tearing the insulation back, in every possible direction, but without making sharp bends around barriers.

NOTE The prohibition against making sharp bends around barriers does not imply that the free wire has to be kept straight during the test. Sharp bends are, moreover, made if it is considered likely that such bends can occur during the normal assembly of the plug or socket-outlet for data centres to be fixed to a wall or a rack, for example when a cover is pushed on.

The free wire of a conductor connected to a live terminal shall not touch any accessible metal part or be able to emerge from the enclosure when the accessory has been assembled.

The free wire of a conductor connected to an earthing terminal shall not touch a live part.

If necessary, the test is repeated with the free wire in another position.

13.24 For rewirable single and multiple socket-outlets for data centres intended to be fixed to a wall or a rack, it shall not be possible to remove covers, cover-plates or parts of them intended to ensure protection against electric shock without the use of a tool.

Compliance is checked as follows:

- *for covers, cover-plates or parts of them whose fixing is of screw-type, compliance is checked by inspection;*
- *for covers, cover-plates or parts of them whose fixing is not dependent on screws and whose removal may give access to live parts, compliance is checked by the tests of 24.13.*

13.25 If covers of rewirable single and multiple socket-outlets for data centres intended to be fixed to a wall or a rack are provided with bushings for the entry holes for the pins, these bushes shall not be removable from the outside or detachable inadvertently from the inside, when the cover is removed.

Compliance is checked by inspection.

13.26 Rewirable single and multiple socket-outlets for data centres intended to be fixed to a wall or a rack shall have means for suspension from a wall or other mounting surfaces and shall be so designed that the suspension means do not allow access to live parts.

There shall be no free openings between the space intended for the suspension means, by which the socket-outlet is fixed to the wall, or other mounting surface and live parts.

Compliance is checked by inspection and by the tests of 24.10, 24.11 and 24.12.

13.27 Combinations of accessories and switches, circuit-breakers or other devices shall comply with the relevant individual IEC standards if a relevant combined product standard does not exist.

Compliance is checked by testing the components according to the relevant IEC standard.

13.28 Components, such as switches and fuses, incorporated in single and multiple socket-outlets for data centres intended to be fixed to a wall or a rack shall comply with the requirements of 14.12.

14 Construction of plugs

14.1 Non-rewirable plugs shall be such that

- the flexible cable cannot be separated from the plug without making it permanently useless, and
- the plug cannot be opened by hand or by using a general purpose tool, for example a screwdriver used as such.

A plug is considered to be permanently useless when parts or materials other than the original are to be used for re-assembling the plug.

Compliance is checked by inspection, by manual test and by the test of 24.13.3.

14.2 Pins of plugs shall have adequate mechanical strength and shall be of solid metal.

Compliance is checked by the test of Clause 24 and by inspection.

14.3 Pins of plugs shall be

- locked against rotation,
- not removable without dismantling the plug,
- adequately fixed in the body of the plug when the plug is wired and assembled as for normal use.

Compliance is checked by inspection and in case of doubt by the tests of Clause 21 and Clause 24.

All exposed surfaces of plug pins shall be smooth and free from burrs or sharp edges and other irregularities which could cause damage or excessive wear to corresponding socket contacts or shutters.

Compliance is checked by inspection and by manual test.

14.4 Pins shall be resistant to corrosion and abrasion.

Pins, which are made of copper or copper alloy as specified in 26.5, are considered as complying with this requirement.

Compliance is checked by inspection or by chemical analysis, if necessary.

14.5 The enclosures of rewirable plugs shall completely enclose the terminals and the ends of flexible cable.

The construction shall be such that the conductors can be properly connected and that, when the plug is wired and assembled as for normal use, it is unlikely that

- pressing the cores together causes damage to the conductor insulation likely to result in a breakdown of the insulation;
- a core, whose conductor is connected to a live terminal, is pressed against accessible metal parts;
- a core, whose conductor is connected to an earthing terminal, is pressed against live parts.

14.6 Rewirable plugs shall be designed in such a way that terminal screws or nuts cannot become loose and fall out of position in such a way that they establish an electrical connection between live parts and the earthing terminal or metal parts connected to the earthing terminal.

Compliance with the requirements of 14.5 and 14.6 is checked by inspection and by manual test.

14.7 Rewirable plugs with earthing contact shall be designed with ample space for slack in the earthing conductor so that, if the strain relief is rendered inoperative, the connection of the earthing conductor is subjected to strain after the connections of the current-carrying conductors and, in case of excessive stress, the earthing conductor will break after the current-carrying conductors.

Compliance is checked by the following test.

The current-carrying conductors of a flexible cable are connected to the plug in such a way that they are led from the strain relief to the corresponding terminals along the shortest possible path. Following which, the core of the earthing conductor is led to its terminal and cut off at a distance 8 mm longer than necessary when using the shortest possible path for its correct connection.

The earthing conductor is then connected to the terminal. It shall then be possible to house the loop, which is formed by the earthing conductor owing to its surplus length when the plug is assembled correctly.

In non-rewirable non-moulded-on plugs with earthing contact, the length of the conductors between the terminations and the cord anchorage shall be adjusted in such a way that the current-carrying conductors will be stressed before the earthing conductor, if the flexible cable slips in its anchorage.

Compliance is checked by inspection.

14.8 Terminals of rewirable plugs and terminations of non-rewirable plugs shall be located or shielded in such a way that loose wires from a conductor in the plug will not present a risk of electric shock.

For non-rewirable moulded-on plugs, means shall be provided to prevent loose wires of a conductor from reducing the minimum isolation distance requirements between such wires and all accessible external surfaces of the plug, with the exception of the engagement face of a plug.

Compliance is checked by the following:

- *for rewirable plugs, the test of 14.8.1;*
- *for non-rewirable non-moulded-on plugs, the test of 14.8.2;*
- *for non-rewirable moulded-on plugs, by verification and inspection according to 14.8.3.*

14.8.1 *A 6 mm length of insulation is removed from the end of a flexible conductor, having the minimum required nominal cross-sectional area specified in Table 1. One wire of the flexible conductor is left free and the remaining wires are fully inserted into and clamped in the terminal as for normal use.*

The free wire is bent, without tearing the insulation back, in every possible direction, but without making sharp bends around barriers.

NOTE The prohibition against making sharp bends around barriers does not imply that the free wire has to be kept straight during the test. Moreover, sharp bends are made if it is considered likely that such bends can occur during the normal assembly of the plug, for example when a cover is pushed on.

The free wire of a conductor connected to a live terminal shall not touch any accessible metal part or be able to emerge from the enclosure when the plug has been assembled.

The free wire of a conductor connected to an earthing terminal shall not touch a live part.

If necessary, the test is repeated with the free wire in another position.

14.8.2 *A length of insulation equivalent to the maximum designed stripping length declared by the manufacturer plus 2 mm is removed from the end of a flexible conductor having the cross-sectional area as fitted. One wire of the flexible conductor is left free in the worst position whilst the remaining wires are terminated in a manner as used in the construction of the plug.*

The free wire is bent, without tearing the insulation back, in every possible direction but without making sharp bends around barriers.

NOTE The prohibition against making sharp bends around barriers does not imply that the free wire has to be kept straight during the test. Moreover, sharp bends are made if it is considered likely that such bends can occur during the normal assembly of the plug, for example when a cover is pushed on.

The free wire of a conductor connected to a live termination shall not touch any accessible metal part or reduce the creepage distance and clearance through any constructional gap below 1,5 mm to the external surface.

The free wire of a conductor connected to an earth termination shall not touch any live part.

14.8.3 *Non-rewirable moulded-on plugs shall be inspected to verify that there are means to prevent stray wires of the conductor and/or live parts reducing the minimum distance through insulation to the external accessible surface below 1,5 mm (with the exception of the engagement face of plugs).*

NOTE The verification of "means" requires the checking of the product construction or assembly method.

14.9 For rewirable plugs:

- it shall be clear how the relief from strain and the prevention of twisting is intended to be effected;
- the cord anchorage, or at least part of it, shall be integral with or securely fixed to one of the component parts of the plug;
- makeshift methods, such as tying the flexible cable in a knot or tying the ends with string, shall not be used;
- the cord anchorage shall be suitable for the different types of flexible cable which may be connected to it;
- screws, if any, which have to be operated to clamp the flexible cable, shall not serve to fix any other component;

NOTE This does not exclude a cover serving to retain the flexible cable in position in the cord anchorage provided the cable remains in place in the plug when the cover is removed.

- cord anchorages shall be of insulating material or be provided with an insulating lining fixed to the metal parts;
- metal parts of cord anchorages, including clamping screws, shall be insulated from the earthing circuit.

Compliance is checked by inspection and, if applicable, by manual test.

14.10 For rewirable plugs and non-rewirable non-moulded-on plugs it shall not be possible to remove covers, cover-plates or parts of them intended to ensure protection against electric shock without the use of a tool.

Compliance is checked as follows:

- *for covers, cover-plates or parts of them whose fixing is of screw-type, compliance is checked by inspection;*
- *for covers, cover-plates or parts of them whose fixing is not dependent on screws and whose removal may give access to live parts, compliance is checked by the tests of 24.13.*

14.11 Screws intended to allow access to the interior of the plug shall be captive.

NOTE The use of tight-fitting washers of cardboard or the like is deemed to be an adequate method for making screws captive.

Compliance with the requirements of 14.11 is checked by inspection.

14.12 Components, such as switches and fuses, incorporated in plugs shall comply with the relevant IEC standard as far as it reasonably applies.

Components incorporated in plugs shall be so rated, or so protected, that overloading of either the component or the plug cannot occur in normal use.

For plugs the incorporated overcurrent protective device shall have a rated current equal to or less than the maximum current at lowest voltage of the plug.

NOTE Examples of overcurrent protective devices are: fuses, thermal or current cut-outs, MCBs (miniature circuit breakers), RCBOs (residual current operated circuit breaker with integral overcurrent protection).

Any other component(s), such as switches or control devices, shall have a rated current not less than

- the maximum current at lowest voltage of the plug, or
- the rated current of the incorporated overcurrent protective device, if any.

For components having different rated currents for resistive and inductive loads, the rated current to be referred to is the rated current for the resistive load.

For non-rewirable plugs, any other incorporated component(s), such as switches or control devices, shall have a rated current not less than

- the test current for the combination of the plugs and the cable as indicated in Table 20, for Clause 21, or
- the rated current of the incorporated overcurrent protective device, if any.

Any incorporated component(s) shall have a rated voltage not less than the rated voltage of the plug.

Compliance is checked by inspection and, if necessary, by testing the component according to the relevant IEC standard.

14.13 If a plug is an integral part of plug-in equipment, that equipment shall not cause overheating of the pins or impose undue strain on fixed socket-outlets.

NOTE Examples of equipment with plugs which are an integral part are lamps with rechargeable batteries, plug-in transformers, etc.

For plugs compliance is checked by the tests of 14.13.1 and 14.13.2.

14.13.1 *The plug of the equipment is inserted into a fixed socket-outlet complying with this part of IEC 62735, the socket-outlet being connected to a supply voltage equal to 1,1 times the highest rated voltage of the equipment.*

After 1 h, the temperature rise of the pins shall not exceed 45 K.

14.13.2 *The equipment is inserted into a fixed socket-outlet complying with this specification, the socket-outlet is pivoted about a horizontal axis through the axis of the live socket-contacts at a distance of 8 mm behind the engagement face of the socket-outlet and parallel to this engagement face.*

The additional torque which has to be applied to the socket-outlet in order to maintain the engagement face in the vertical plane shall not exceed 0,25 N·m.

14.14 Plugs shall be shaped in such a way and/or made of such material that they can easily be withdrawn by hand from the relevant socket-outlets.

In addition the gripping surfaces shall be so designed that the plug can be withdrawn without having to pull the flexible cable.

Compliance is checked by inspection and in case of doubt by a gripping test.

NOTE Examples of possible gripping tests are given in Annex C

14.15 Membranes in inlet openings of plugs shall meet the requirements of 13.19.

15 Interlocked socket-outlets

Socket-outlets interlocked with a switch shall be constructed in such a way that a plug cannot be inserted into or completely withdrawn from the socket-outlet while the socket-contacts are live, and the socket-contacts of the socket-outlet cannot be made live until a plug is almost completely in engagement.

Compliance is checked by inspection and by manual test.

NOTE Other test requirements are under consideration to be covered by a future part 2.

16 Resistance to ageing, protection provided by enclosures, and resistance to humidity

16.1 Resistance to ageing

Accessories shall be resistant to ageing.

Parts intended for decorative purposes only, such as certain lids, shall be removed if possible and these parts are not subjected to the test.

Compliance is checked by the following test.

Accessories, mounted as for normal use, are subjected to a test in a heating cabinet with an atmosphere having the composition and pressure of the ambient air and ventilated by natural circulation.

For socket-outlets for data centres intended to be fixed to a wall or a rack, a test plug as specified in Clause 20 shall be inserted into the socket-outlet during the test.

For accessories having lids the test plug shall be so designed that when it is inserted the lid can be closed.

The temperature in the cabinet shall be (70 ± 2) °C.

The specimens are kept in the cabinet for seven days (168 h).

The use of an electrically heated cabinet is recommended.

Natural circulation may be provided by holes in the wall of the cabinet.

After the treatment, the specimens are removed from the cabinet and kept at a room temperature and relative humidity between 45 % and 55 % for at least four days (96 h).

The specimens shall show no crack visible with normal or corrected vision without additional magnification, nor shall the material have become sticky or greasy, this being judged as follows:

- with the forefinger wrapped in a dry piece of rough cloth the specimen is pressed with a force of 5 N;*
- no traces of the cloth shall remain on the specimen and the material of the specimen shall not stick to the cloth.*

After the test, the specimens shall show no damage which would lead to non-compliance with this part of IEC 62735.

The force of 5 N can be obtained in the following way:

- the specimen is placed on one of the pans of a balance and the other pan is loaded with a mass equal to the mass of the specimen plus 500 g;*
- equilibrium is then restored by pressing the specimen with the forefinger, wrapped in a dry piece of rough cloth.*

16.2 Protection provided by enclosures

16.2.1 General

Enclosures shall provide protection against access to hazardous parts, harmful effects due to ingress of solid foreign objects in accordance with the IP designation of the accessory.

Compliance is checked by the tests of 16.2.2.

16.2.2 Protection against access to hazardous parts and against harmful effects due to ingress of solid foreign objects

16.2.2.1 General

Accessories and their enclosures shall provide a degree of protection against access to hazardous parts and against harmful effects due to ingress of solid foreign objects, which shall be at least IP20.

Fixed socket-outlets are mounted as in normal use on a vertical surface. Flush-type and semi-flush type socket-outlets are mounted in an appropriate box according to the manufacturer's instructions.

Accessories with screwed glands or membranes are fitted and connected with cables which shall be within the connecting range specified in Table 1. Glands are tightened with a torque equal to two-thirds of that applied during the test of 24.7.

Screws of the enclosure are tightened with a torque equal to two-thirds of the value given in Table 4.

Parts which can be removed without the aid of a tool are removed.

If an accessory has passed the test successfully, then this test is deemed to be passed for a combination of such single accessories.

Glands shall not be filled with sealing compound or the like.

16.2.2.2 Protection against access to hazardous parts

The appropriate test specified in IEC 60529 is performed (see also Clause 10).

16.2.2.3 Protection against harmful effects due to ingress of solid foreign objects

The appropriate test specified in IEC 60529 is performed.

16.3 Resistance to humidity

Accessories shall be proof against humidity which may occur in normal use.

Compliance is checked by the humidity treatment described in 16.3, followed immediately by the measurement of the insulation resistance and by the electric strength test specified in Clause 17.

Inlet openings, if any, are left open; if knock-outs are provided, one of them is opened.

Parts which can be removed without the aid of a tool are removed and subjected to the humidity treatment along with the main part; spring lids are open during this treatment.

The humidity treatment is carried out in a humidity cabinet containing air with a relative humidity maintained between 91 % and 95 %.

The temperature of the air in which the specimens are placed is maintained within ± 1 K of any convenient value t between 20 °C and 30 °C.

Before being placed in the humidity cabinet, the specimens are brought to a temperature between t and $(t + 4)$ °C.

The specimens are kept in the cabinet for two days (48 h).

In most cases, the specimens may be brought to the specified temperature by keeping them at this temperature for at least 4 h before the humidity treatment.

A relative humidity between 91 % and 95 % can be obtained by placing in the humidity cabinet a saturated solution of sodium sulphate (Na_2SO_4) or potassium nitrate (KNO_3) in water, having a sufficiently large contact surface with the air.

In order to achieve the specified conditions within the cabinet, it is necessary to ensure constant circulation of the air within and, in general, to use a cabinet which is thermally insulated.

After this treatment, the specimens shall not show any damage which impairs safety as required by Clause 4.

17 Insulation resistance and electric strength

17.1 The insulation resistance and electric strength of accessories shall be adequate.

Compliance is checked by the following tests, which are made immediately after the test of 16.3, in the humidity cabinet or in the room in which the specimens were brought to the prescribed temperature, after re-assembly of those parts which can be removed without the aid of a tool, which were removed for the test.

17.2 The insulation resistance is measured with a d.c. voltage of approximately 1 000 V, the measurement being made 1 min after application of the voltage.

The insulation resistance shall be not less than 5 M Ω .

17.2.1 For socket-outlets, the insulation resistance is measured consecutively:

- a) *between all poles connected together and the body, the measurement being made with a plug in engagement;*
- b) *between each pole in turn and all others, these being connected to the body with a plug in engagement;*
- c) *between any metal enclosure and metal foil in contact with the inner surface of its insulating linings, if any – this test is only made if an insulating lining is necessary to provide insulation;*
- d) *between any metal part of the cord anchorage, including clamping screws, and earthing terminal(s) or earthing contact(s), if any, of socket-outlets for data centres to be fixed to a wall or a rack;*
- e) *between any metal part of the cord anchorage of socket-outlets for data centres intended to be fixed to a wall or a rack and a metal rod of the maximum diameter of the flexible cable inserted in its place (see Table 17).*

The term "body" used in a) and b) includes all accessible metal parts, metal frames supporting the base of flush-type socket-outlets, metal foil in contact with the outer surface of accessible external parts of insulating material, fixing screws of bases or covers and cover-plates, external assembly screws, earthing terminals or earthing contacts.

Measurements d) and e) are not made on fixed socket-outlets and socket-outlets for assemblies.

While wrapping the metal foil round the outer surface or placing it in contact with the inner surface of parts of insulating material, it is pressed against holes or grooves, without any appreciable force, by means of a straight unjointed test finger test probe 11 of IEC 61032.

17.2.2 For plugs, the insulation resistance is measured consecutively

- a) *between all poles connected together and the body;*
- b) *between each pole in turn and all others, these being connected to the body;*
- c) *between any metal part of the cord anchorage, including clamping screws, and earthing terminal(s) or earthing contact(s), if any;*
- d) *between any metal part of the cord anchorage and a metal rod of the maximum diameter of the flexible cable inserted in its place (see Table 17).*

The term "body" used in a) and b) includes accessible metal parts, external assembly screws, earthing terminals, earthing contacts and a metal foil in contact with the outer surface of accessible external parts of insulating material, other than the engagement face.

Measurements c) and d) are not made on non-rewirable plugs.

While wrapping the metal foil round the outer surface or placing it in contact with the inner surface of parts of insulating material, it is pressed against holes or grooves, without any appreciable force, by means of a straight unjointed test finger test probe 11 of IEC 61032.

17.3 *A d.c. voltage of 3 000 V is applied for 1 min between the parts indicated in 17.2.*

Initially, not more than half the prescribed voltage is applied, then it is raised rapidly to the full value.

No flashover or breakdown shall occur during the test.

The test equipment shall be so designed that, when the output terminals are short-circuited after the output voltage has been adjusted to the appropriate test voltage, the output current is at least 200 mA.

The overcurrent relay shall not trip when the output current is less than 100 mA.

The test voltage applied shall be measured within $\pm 3\%$.

Glow discharges without drop in the voltage are neglected.

18 Operation of earthing contacts

18.1 Operation of earthing contacts under normal conditions

Earthing contacts shall provide adequate contact pressure and shall not deteriorate in normal use.

Compliance is checked by the tests of Clauses 19 and 21.

18.2 Operation of earthing contacts under fault conditions

Socket-outlets shall be so designed that the earthing contacts are adequate to ensure that they are able to connect safely under fault conditions. This means that the earthing path shall retain its integrity after removing and reinserting the plug.

Compliance is checked by the following test.

The socket-outlet shall be mounted as in Clause 17.

The prospective short-circuit current of the supply shall be 1 000 A at a voltage equal to 200 V.

The prospective let-through I^2t value shall be 15 000 A²s.

The socket-outlet and the plug are tested in a circuit (Figure 34) where the plug has a short circuit (Z_2) between line and earth.

NOTE The I^2t value of 15 000 A²s corresponds to a typical unfavourable let-through I^2t value of 10 A miniature circuit-breakers measured at 1 500 A prospective short-circuit current.

The diagram of the circuit in which the socket-outlet is tested is shown in Figure 34.

The impedance Z_1 (short-circuit impedance) shall be adjustable to satisfy the specified prospective short-circuit current.

The circuit is calibrated with the following tolerances: current $\pm 5\%$, voltage $\pm 10\%$, I^2t value $\pm 10\%$.

The socket-outlet shall be tested while the “+” terminal is connected to an appropriate 200 V d.c. supply and the earthing terminal is connected to earth. The line and earthing terminals of the test plug are short circuited (Z_2). The short circuit on the plug shall be capable of withstanding the 1 000 A short-circuit current. The socket outlet shall be rigidly supported.

The short circuit is caused by plugging in a short circuited plug.

After application of the earth fault, the mating plug shall be removed.

The test is repeated with the “-” terminal connected to an appropriate 200 V d.c. supply and the earthing terminal connected to the earth.

The socket-outlet and the plug are deemed to have passed the test when the following conditions are fulfilled:

- 1) *Socket-outlets shall be capable of accepting a mating plug.
Compliance is checked by inspection.*
- 2) *Live parts shall not be accessible.
Compliance is checked by the tests of Clause 10.*
- 3) *There shall be no damage to the earthing path.
Compliance is checked by submitting the socket-outlet to the temperature rise test according to Clause 19 where the current flows through the earth and the tested phase.*
- 4) *Socket-outlets shall maintain electrical continuity between the earthing pin of the plug and earthing socket-outlet contact.
Compliance is checked by the tests of Clause 11.*

19 Temperature rise

19.1 Accessories shall be so constructed that they comply with the following temperature rise test.

Socket-outlets and plugs are tested according to 19.2 except for plugs and socket-outlets with incorporated components, for which 19.3 applies.

Non-rewirable accessories are tested as delivered.

Rewirable accessories are fitted with polyvinyl chloride insulated conductors having a nominal cross-sectional area as shown in Table 15.

Table 15 – Nominal cross-sectional areas of copper conductors and test currents for the temperature rise test

Type of accessory	Test current		Cross-sectional area for the conductor
	Clause 19	Clause 21	
Fixed socket-outlet and socket-outlet for assemblies	11,6 A	8,8 A	1,5 mm ² or AWG 16
Socket-outlet for data centres to be fixed to a wall or a rack	11,6 A	8,8 A	1,5 mm ² or AWG 16
Moulded-on plug	8,8 A	6,7 A	0,75 mm ² or AWG 18
	11,6 A	8,8 A	1 mm ²
	11,6 A	8,8 A	1,5 mm ² or AWG 16
Rewirable plug	8,8 A	6,7 A	0,75 mm ² or AWG 18
	11,6 A	8,8 A	1 mm ² or AWG 16

NOTE 1 The values in this table are based upon a circuit which is protected by an 8 A circuit breaker.

If a fixed multiple socket-outlet is designed to be connected to the fixed wiring via a circuit breaker complying with IEC 60898-2 with a rated current higher than 8 A, the conductor between the circuit breaker and the socket-outlet shall be adequately sized.

The terminal screws or nuts are tightened with a torque equal to two-thirds of that specified in 12.2.8.

To ensure normal cooling of the terminals, the conductors connected to them shall have a length not less than 1 m.

Flush-mounted accessories and accessories for assemblies are mounted in flush-mounted boxes. The box is placed in a block of pinewood filled around the box with plaster, so that the front edge of the box does not protrude and is not more than 5 mm below the front surface of the pinewood block.

The test assembly shall be allowed to dry for at least seven days when first made.

The size of the pinewood block, which may be fabricated from more than one piece, shall be such that there is at least 25 mm of wood surrounding the plaster, the plaster having a thickness between 10 mm and 15 mm around the maximum dimensions of the sides and rear of the box.

The cable(s) connected to the socket-outlet shall enter through the top of the box, the point(s) of entry being sealed to prevent the circulation of air. The length of each conductor within the box shall be (80 ± 10) mm.

Surface-type fixed socket-outlets and the socket-outlets for data centres intended to be fixed to a wall or a rack shall be mounted centrally on the surface of a wooden block, which shall be at least 20 mm thick, 500 mm wide and 500 mm high.

The test assembly shall be placed in a draught-free environment for the test.

In the case of multiple socket-outlets, the test is carried out on the least favourable socket-outlet(s) with the test current as specified in Table 15 passed through.

The temperature rise of the terminals, terminations, socket contact engaged with the pin of a plug and clamping units according to Figure 31 determined by means of thermocouples shall not exceed 45 K.

For the purpose of the test of 25.4, the temperature rise of external parts of insulating material not necessary to retain current-carrying parts and parts of the earthing circuit in position, even though they are in contact with them, shall also be determined.

19.2 Tests for socket-outlets and plugs

Socket-outlets are tested using a test plug with brass pins having the minimum specified dimensions.

A test plug is inserted into the each relevant socket-outlet.

First, accessories shall be tested by passing a current as defined in Table 15 through the “+” contact and the “–” contact for 60^{+5}_0 min. Second, accessories shall be tested by passing a current as defined in Table 15 through either the “+” contact or the “–” contact and the earthing contact for 60^{+5}_0 min.

In case of multiple socket-outlets the test is performed by adding a load so as to pass a current as defined in Table 15 through the socket-outlet at the most unfavourable position in terms of temperature rise (e.g. the socket-outlet which is the furthest away from where the accessory is supplied) and an additional load resulting in the feed-through current as defined in Table 15 to the next unfavourable socket-outlet.

NOTE See Figure 35 for a possible test setup.

For this test the temperature rise is measured on the terminals, socket contact engaged with the pin of a plug and terminations.

Plugs are tested as follows.

The plug shall be tested in a draught-free environment at the centre of a plane wooden sheet which shall be at least 20 mm thick, 500 mm wide and 500 mm high.

Clamping units having the dimensions specified in Figure 31 are fitted on each live pin and earthing pin of the plug. Each clamping unit is equipped with a thermocouple which can be mounted either together with the pin or fixed permanently within the dotted area of Figure 31.

If it is not possible to use the clamping unit of Figure 31 due to the design of the plug, the clamping unit may be modified in order to perform the test.

In this case the diameter of the screw, the threaded hole and the total volume of the modified clamping unit shall be identical to Figure 31.

The screw is then placed approximately in the middle of the bare part of the pin and tightened with a torque of 0,8 N·m.

A current as specified in Table 15 is then passed for 60^{+5}_0 min.

19.3 Tests for plugs and socket-outlets for data centres intended to be fixed to a wall or a rack with incorporated components

Socket-outlets for data centres intended to be fixed to a wall or a rack and plugs with incorporated components are tested by the following two tests:

- *with a current as indicated in Table 15, for Clause 19 – for this test the incorporated components are short circuited;*

- *with a current as indicated in Table 15 or the rated current of the component(s), whichever is the lower.*

In addition to the verification of the temperature rise of the terminals, the maximum temperature rise of accessible metal parts shall be measured and shall not be higher than 30 K and of accessible non-metallic parts not higher than 40 K.

NOTE Examples of 'incorporated components' are switches and fuses.

20 Breaking capacity

Accessories shall have adequate breaking capacity.

Compliance is checked by testing socket-outlets by means of an appropriate test apparatus, an example of which is shown in Figure 14.

Rewirable accessories are fitted with conductors as specified for the test of Clause 19.

In case of failure of the shutters, the test on shuttered socket-outlets shall be repeated with operations made by hand.

Socket-outlets are tested using a test plug with brass pins (Type CuZn39Pb2-M) and having dimensions as specified in the relevant standard sheets.

Plugs are tested using a fixed socket-outlet complying with this part of IEC 62735 and having as near-to-average characteristics as can be selected.

The length of the stroke of test apparatus is between 50 mm and 60 mm.

First the test is done with a test voltage of 260 V and a test current of 1,5 times 10 A with an inrush of 300 A with a profile equivalent to that shown in Figure 32, for 100 strokes.

The periods during which the test current is passed from the insertion of the plug until subsequent withdrawal is $1,5^{+0,5}_0$ s.

The average speed of insertion and withdrawal of the plug during the test is 0,15 m/s.

No current is passed through the earthing circuit.

The test is made with the connections shown in Figure 15.

After this test the test is repeated with a test voltage of 410 V and a test current of 1,5 times 6,34 A with an inrush of 475 A with a profile equivalent to that shown in Figure 32, for 100 strokes.

No current is passed through the earthing circuit.

Accessible metal parts, metal supports and any metal frame supporting the base of flush-type socket-outlets are connected through the selector switch C to one of the poles of the supply for half the number of strokes, and to the other pole for the remainder.

In the case of multiple socket-outlets, the test is carried out on one socket-outlet.

During the test, no sustained arcing shall occur.

The line fuse or the grounding fuse shall not open during the test.

After the test, the specimens shall show no damage impairing their further use and the entry holes for the pins shall not show any damage which impairs safety as required by Clause 4.

21 Normal operation

Accessories shall withstand, without excessive wear or other harmful effect, the mechanical, electrical and thermal stresses occurring in normal use.

Compliance is checked by testing socket-outlets by means of an appropriate test apparatus, an example of which is shown in Figure 14.

The test pins (during the socket-outlet test) shall be replaced after 4 500 and 9 000 strokes.

The procedure specified in Figure 30 shall be followed.

The manufacturer shall be permitted to indicate at which point 1, 2 or 3 of Figure 30 the test program shall begin. If the manufacturer indicates to start at point 2 or point 3, the test shall be performed on new specimens that have previously been subjected to the test of Clause 20 in the conditions required to the relevant starting points 2 or 3.

Socket-outlets are tested using a plug with brass pins (Type CuZn39Pb2-M) complying with the standard sheets.

Plugs are tested using a fixed socket-outlet complying with this part of IEC 62735 and having as near to average characteristics as can be selected.

The specimens are first tested with a direct current of 6,5 A, at a voltage of 400 V, in a circuit producing an inrush current equal to 463 A with a profile equivalent to that shown in Figure 32, for 5 000 strokes at a rate of 30 strokes per minute.

Then the specimens are further tested with a direct current of 8,8 A, at a voltage of 294 V, in a circuit producing an inrush current equal to 340 A with a profile equivalent to that shown in Figure 32, for 5 000 strokes at a rate of 30 strokes per minute.

The test current is passed during each insertion and withdrawal of the plug.

The periods during which the test current is passed from insertion of the plug until subsequent withdrawal are $1,5^{+0,5}_0$ s.

The average speed of insertion and withdrawal of the plug during the test is 0,15 m/s.

No current is passed through the earthing circuit.

During the test, no sustained arcing shall occur.

The line fuse or the grounding fuse shall not open during the test.

The test is made with the connections indicated in Clause 20, the selector switch C being operated as prescribed in that clause.

In the case of multiple socket-outlets, the test is carried out on one socket-outlet of each type and current rating.

After the tests, the specimens shall not show

- wear impairing their further use,*
- deterioration of enclosures, insulating linings or barriers,*
- damage to the entry holes for the pins, that might impair proper working,*
- loosening of electrical or mechanical connections,*
- seepage of sealing compound.*

For shuttered socket-outlets, a gauge according to Figure 9 is applied to the entry holes corresponding to the live contacts with a force of 20 N.

The gauge is applied to the shutters in the most unfavourable position, successively in three directions to the same place, for approximately 5 s in each of the three directions.

During each application, the gauge shall not be rotated and it shall be applied such that the force of 20 N is maintained. When moving the gauge from one direction to the next, no force is applied but the gauge is not withdrawn.

A gauge according to Figure 10 is then applied with a force of 1 N and in three directions, for approximately 5 s in each of the three directions, with independent movements, withdrawing the gauge after each movement.

It shall not be possible to touch live parts with the gauges of Figures 9 and 10 when they remain under the relevant forces.

An electrical indicator, with a voltage between 40 V and 50 V, is used to show contact with the relevant part.

The specimens shall then comply with the requirements of Clause 19, using a test current as specified in Table 15. The temperature rise, at any point, shall not exceed 45 K, and the specimens shall withstand an electric strength test made according to 17.3, the test voltage being reduced to 2 000 V d.c.

The humidity treatment, according to 16.3, is not repeated before the electric strength test of Clause 21.

The tests of 13.2 and 14.2 are made after the tests of Clause 21.

22 Force necessary to withdraw the plug

22.1 General

The construction of accessories shall allow the easy insertion and withdrawal of the plug, and prevent the plug from working out of the socket-outlet in normal use.

Compliance is checked as follows.

For socket-outlets by:

- a test to ascertain that the maximum force necessary to withdraw the test plug from the socket-outlet is not higher than the force specified in Table 16, and*
- a test to ascertain that the minimum force necessary to withdraw a single pin gauge from the individual contact assembly is not lower than the force specified in Table 16.*

22.2 Verification of the maximum withdrawal force for socket-outlets

The socket-outlet is fixed to the mounting plate A of apparatus as shown in Figure 16, so that the axes of the socket-contacts are vertical and the entry holes for the pins of the plug face downwards.

The test plugs have finely ground pins of hardened steel, having a surface roughness between $0,6 \mu\text{m}$ ($\frac{0,6}{\sqrt{\text{V}}}$) and $0,8 \mu\text{m}$ ($\frac{0,8}{\sqrt{\text{V}}}$) over their active length.

The dimensions of the gauge are given in gauge C4max, Annex D.

The pins are wiped free from grease, before each test, using a cold chemical degreaser.

The gauge C4max is inserted into and withdrawn from the socket-outlet ten times. It is then inserted again, a carrier E for a principal mass F and a supplementary mass G being attached to it by means of a suitable clamp D. The supplementary mass is such that it exerts a force equal to one-tenth of the maximum withdrawal force shown in Table 16.

The principal mass, together with the supplementary mass, the clamp, the carrier and the plug exert a force equal to the maximum withdrawal force shown in Table 16.

The principal mass is hung on the plug without jolting and the supplementary mass is, if necessary, allowed to fall from a height of 50 mm onto the principal mass.

The plug shall not remain in the socket-outlet.

22.3 Verification of the minimum withdrawal force

The “+” and “-” socket-contacts are tested individually, using gauge C4Amin with the socket-outlet held in such way that the gauge is hanging downwards.

Shutters, if any, are rendered inoperative so as not to affect the test.

The protective earthing socket-contact is tested, using gauge C4Bmin with the socket-outlet held in such way that the gauge is hanging downwards.

The test pin gauge is made of hardened steel, having a surface roughness between $0,6 \mu\text{m}$ ($\frac{0,6}{\sqrt{\text{V}}}$) and $0,8 \mu\text{m}$ ($\frac{0,8}{\sqrt{\text{V}}}$) over its active length.

The force of the gauge shall be equal to that specified in Table 16.

The pin is wiped free from grease, before each test, using a cold chemical degreaser.

The test pin gauge is inserted into the contact assembly.

The test pin gauge is applied gently, and care is taken not to knock the assembly when checking the minimum withdrawal force. The gauge shall not fall from the contact assembly within 30 s.

Table 16 – Maximum and minimum withdrawal force for plugs and socket-outlets

Rating of the accessory	Number of poles of the accessory	Withdrawal force N	
		Multi-pin gauge maximum	Single-pin gauge minimum
2,6 kW	3	50	1,5

23 Flexible cables and their connection

23.1 Rewirable plugs and socket-outlets for data centres intended to be fixed to a wall or a rack shall be provided with a cord anchorage such that the conductors are relieved from strain, including twisting, where they are connected to the terminals and that their covering is protected from abrasion.

The sheath, if any, of the flexible cable shall be clamped within the cord anchorage.

Compliance is checked by inspection and by the test of 23.2.

Non-rewirable plugs shall be designed such that the cable is maintained in position and the terminations are relieved from strain and twisting.

The sheath, if any, of the flexible cable shall be maintained inside the accessory.

Compliance is checked by the test of 23.2 and 23.4.

23.2 *The effectiveness of the retention of the cable by the cord anchorage is checked by the following test by means of apparatus as shown in Figure 17.*

Non-rewirable plugs are tested as delivered; the test is made on new specimens.

Rewirable accessories are first tested with a cable having the smallest nominal cross-sectional area, and then with a cable having the largest nominal cross-sectional area, as shown in Table 17.

Accessories designed exclusively for use with flat flexible cables are tested only with the types of flat flexible cables specified.

Table 17 – External dimensions of flexible cables to be accommodated by cord anchorages

Rating of accessory	Number of poles ^a	Types of flexible cable (cable references)	Number of conductors and nominal cross-sectional area or AWG size	Limits for external dimensions for flexible cables mm	
				Minimum	Maximum
2,6 kW / 400 V	3	60227 IEC 53	3 × 0,75 mm ² or 18 AWG	6,4	8,4
		60227 IEC 53	3 × 1 mm ² or 16 AWG		

^a Earthing contacts, irrespective of their number, are considered as one pole.

Conductors or flexible cables of rewirable accessories are introduced into the terminals, the terminal screws being tightened just sufficiently to prevent the position of the conductors from easily changing.

The cord anchorage is used in the normal way, clamping screws, if any, being tightened with a torque equal to two-thirds of that specified in Table 4.

After reassembly of the specimen, the component parts shall fit snugly and it shall not be possible to push the flexible cable into the specimen to any appreciable extent.

The specimen is placed in the test apparatus so that the axis of the flexible cable is vertical where it enters the specimen.

The flexible cable is then subjected 100 times to a pull of 60 N.

The pull force is applied each time in one smooth and continuous motion for 1 s.

Exert the same pull on all parts (core, insulation and sheath) of the flexible cable simultaneously.

Immediately afterwards, the flexible cable is subjected for 1 min to a torque as specified in Table 18.

Table 18 – Torque test values for cord anchorages

Rating of plug or socket-outlet for data centres to be fixed to a wall or a rack	Flexible cable (number of cores × nominal cross-sectional area or AWG size)	
	3 × 0,75 mm ² or 18 AWG	3 × 1 mm ² or 16 AWG
2,6 kW / 400 V	0,25 N·m	0,25 N·m

After the tests, the flexible cable shall not have been displaced by more than 2 mm. For rewirable accessories, the end of the conductors shall not have moved noticeably in the terminals; for non-rewirable accessories, there shall be no break in the electrical connections.

For measurements of the longitudinal displacement, a mark is made on the flexible cable at a distance of approximately 20 mm from the end of the specimen or the flexible cable guard, before it is subjected to the pull.

If, for non-rewirable accessories, there is no definitive end to the specimen or the flexible cable guard, an additional mark is made on the body of the specimen.

The displacement of the mark on the flexible cable in relation to the specimen or flexible cable guard is measured while the flexible cable is subjected to the pull.

In addition, for rewirable accessories, it shall be checked by a manual test that they are suitable for fitting with the appropriate cable, as shown in Table 19.

Table 19 – Maximum dimensions of flexible cables to be accommodated in rewirable accessories

Rating of accessory	Number of poles ^a	Types of flexible cable (cable references)	Number of conductors and nominal cross-sectional area	Maximum dimensions for flexible cables mm
2,6 kW / 400 V	3	60245 IEC 53	3 × 1 mm ² or 16 AWG	9,2
^a Earthing contact is considered as one pole.				

23.3 Non-rewirable plugs shall be provided with a flexible cable complying with IEC 60227 or IEC 60245. The nominal cross-sectional areas of the conductors in relation to the rating of accessories are given in the relevant columns of Table 15.

NOTE Table 20 also specifies the test currents for the test of temperature rise and normal operation.

Flexible cables shall have the 3 conductors. The conductor connected to the earthing contact shall be identified by the colour combination green/yellow.

Compliance is checked by inspection, by measurement and by checking that the flexible cables are in accordance with the relevant parts of either IEC 60227 or IEC 60245, as applicable.

23.4 Non-rewirable plugs shall be designed in such a way that the flexible cable is protected against excessive bending where it enters the accessory.

Guards provided for this purpose shall be of insulating material and shall be fixed in a reliable manner.

Helical metal springs, whether bare or covered with insulating material, shall not be used as flexible cable guards.

Compliance is checked by inspection and by a flexing test made by means of apparatus as shown in Figure 18.

The test is made on new specimens.

The specimen is fixed to the oscillating member of the apparatus so that, when it is at the middle of its travel, the axis of the flexible cable, where it enters the specimen, is vertical and passes through the axis of oscillation.

Specimens with flat cords are mounted so that the major axis of the section is parallel to the axis of oscillation.

The plugs shall be fixed in the test apparatus by the pin.

The accessory is, by variation of the distance between the fixing part of the oscillating member and the axis of oscillation, positioned so that the flexible cable makes the minimum lateral movement when the oscillating member of the test apparatus is moved over its full travel.

In order to have the possibility of easily finding by experiment the mounting position with a minimum lateral movement of the flexible cable during the test, the flexing apparatus should

be built in such a way that the different supports for the accessories mounted on the oscillating member can be readily adjusted.

It is recommended to have a device (for example, a slot or a pin) to see whether the flexible cable makes the minimum lateral movement.

The flexible cable is loaded with a mass such that the force applied is

- 20 N for accessories with flexible cables having a nominal cross-sectional area exceeding 0,75 mm²;*
- 10 N for other accessories.*

A current equal to 6,84 A is passed through the conductors;

The voltage between the conductors is equal to 380 V.

The oscillating member is moved through an angle of 90° (45° on either side of the vertical), the number of flexings being 10 000 at a rate of 60 flexings per minute.

A flexing is one movement, either backwards or forwards.

Specimens with circular-section flexible cables are turned through 90° in the oscillating member after 5 000 flexings; specimens with flat flexible cables are only bent in a direction perpendicular to the plane containing the axes of the conductors.

During the flexing test, there shall be

- no interruption of the current longer than 10 ms,*
- no short circuit between conductors.*

A short-circuit between the conductors of the flexible cable is considered to occur if the current attains a value equal to twice the test current of the accessory.

After the test, the guard, if any, shall not have separated from the body and the insulation of the flexible cable shall show no sign of abrasion or wear; broken strands of the conductors shall not have pierced the insulation so far as to become accessible.

24 Mechanical strength

24.1 Accessories, surface mounting boxes, screwed glands and shrouds shall have adequate mechanical strength so as to withstand the stresses imposed during installation and use.

Compliance is checked by the appropriate tests as follows:

- for all kinds of fixed socket-outlets and socket-outlets for assemblies 24.2, 24.13;
- for fixed socket-outlets with a base intended to be mounted directly on a surface 24.4, 24.13;
- for single and multiple socket-outlets for data centres to be fixed to a wall or a rack 24.2, 24.10, 24.11 and 24.12;
- for plugs:
 - with enclosures, covers or bodies other than of elastomeric or thermoplastic material 24.3 and 24.9;
 - with enclosures, covers or bodies of elastomeric or thermoplastic material 24.3, 24.5, 24.6 and 24.9;
- for socket-outlets and plugs with screwed glands 24.7;
- for shuttered socket-outlets 24.8;
- for shroud of plugs 24.18.

24.2 The specimens are subjected to blows by means of impact-test apparatus as given in IEC 60068-2-75.

Surface-type socket-outlets and surface-mounting boxes are mounted on the plywood as in normal use.

Inlet openings which are not provided with knock-outs are left open; if they are provided with knock-outs, one of them is opened.

Flush-type socket-outlets are mounted in a recess provided in a block of hornbeam or material having similar mechanical characteristics, which is fixed to a sheet of plywood, and not in its relevant mounting box.

If wood is used for the block, the direction of the wood fibres shall be perpendicular to the direction of impact.

Flush-type screw fixing socket-outlets shall be fixed by means of screws to lugs recessed in the hornbeam block. Flush-type claw fixing socket-outlets shall be fixed to the block by means of the claws.

Before applying the blows, fixing screws of bases and covers are tightened with a torque equal to two-thirds of that specified in Table 4.

The specimens are mounted so that the point of impact lies in a vertical plane through the axis of the pivot.

The striking element is allowed to fall from a height specified in Table 20.

Table 20 – Height of fall for impact tests

Height of fall mm	Parts of enclosures subjected to impact
80	A and B
140	C
160	D
200	–

A Parts on the front surface, including the parts which are recessed.

B Parts which do not project more than 15 mm from the mounting surface (distance from the wall) after mounting as in normal use, with the exception of parts specified in A.

C Parts other than those specified in A which project more than 15 mm and not more than 25 mm from the mounting surface (distance from the wall) after mounting as in normal use.

D Parts other than those specified in A which project more than 25 mm from the mounting surface (distance from the wall) after mounting as in normal use.

The impact energy determined by the part of the specimen which projects most from the mounting surface is applied on all parts of the specimen, with the exception of those specified in A.

The specimens are subjected to blows, which are evenly distributed. The blows are not applied to knock-outs.

The following blows are applied.

- *For parts specified in A, five blows (see Figure 19a and Figure 19b):*
 - *one blow to the centre;*
 - *one blow on each of the two most unfavourable points between the centre and the edges, after the specimen has been moved horizontally;*
 - *one blow on similar points, after the specimen has been turned 90° about its axis perpendicular to the plywood.*
- *For parts specified in B (as far as applicable), C and D, four blows:*
 - *one blow on one of the sides of the specimen where the blow can be applied, after the plywood sheet has been turned 60° about a vertical axis (see Figure 19c);*
 - *one blow on the opposite side of the specimen where blows can be applied, after the plywood sheet has been turned 60° about a vertical axis, in the opposite direction (see Figure 19c).*

After the specimen has been turned 90° about its axis perpendicular to the plywood sheet:

- *one blow is applied on one of the sides of the specimen where the blow can be applied, after the plywood sheet has been turned 60° about a vertical axis (see Figure 19d);*
- *one blow on the opposite side of the specimen where blows can be applied, after the plywood sheet has been turned 60° about a vertical axis in the opposite direction (see Figure 19d).*

If inlet openings are provided, the specimen is mounted in such a way that the two lines of blows are, as closely as possible, equidistant from these openings.

Cover-plates and other covers of multiple socket-outlets are treated as though they were the corresponding number of separate covers, but only one blow is applied to any one point.

After the test, the specimen shall not show any damage which impairs safety as required by Clause 4. In particular, live parts shall not become accessible.

After the test on a lens (window for pilot lights) the lens may be cracked and/or dislodged, but it shall not be possible to touch live parts with

- the test probe B of IEC 61032 under the conditions stated in 10.2;*
- the test probe 11 of IEC 61032 under the conditions stated in 10.2, but with a force of 10 N;*
- the steel wire of Figure 10, applied with a force of 1 N, for accessories with increased protection.*

In case of doubt, it is verified that it is possible to remove and replace external parts such as boxes, enclosures, covers and cover-plates, without these parts or their insulating lining being broken.

If a cover-plate backed by an inner cover is broken, the test is repeated on the inner cover, which shall remain unbroken.

Damage to the finish, small dents which do not reduce creepage distances or clearances below the value specified in 27.1 and small chips which do not adversely affect the protection against electric shock are ignored.

Cracks not visible with normal or corrected vision, without additional magnification, and surface cracks in fibre-reinforced mouldings and the like are ignored.

Cracks or holes in the outer surface of any part of the accessory are ignored if the accessory complies with this specification even if this part is omitted. If a decorative cover is backed by an inner cover, fracture of the decorative cover is ignored if the inner cover withstands the test after removal of the decorative cover.

24.3 *Rewirable plugs are fitted with the flexible cable specified in 23.2 having the smallest nominal cross-sectional area specified in Table 1 and a free length of approximately 100 mm measured from the outer end of the guard.*

Terminal screws and assembly screws are tightened with a torque equal to two-thirds of that specified in Table 4.

Non-rewirable accessories are tested as delivered, the flexible cable being cut so that a free length of about 100 mm projects from the accessory.

The specimens are individually subjected to the test Free fall repeated, procedure 2 of IEC 60068-2-31, the number of falls being

- 1 000 if the mass of the specimen without flexible cable does not exceed 100 g,*
- 500 if the mass of the specimen without flexible cable exceeds 100 g, but does not exceed 200 g, and*
- 100 if the mass of the specimen without flexible cable exceeds 200 g.*

The barrel is turned at a rate of five revolutions per minute, 10 falls per minute thus taking place.

After the test, the specimens shall not show any damage which impairs safety as required by Clause 4. In particular,

- no part shall have become detached or loosened;*

- the pins shall not have become so deformed that the plug cannot be introduced into a socket-outlet complying with the relevant standard sheet and also fails to comply with the requirements of Clause 9 and 10.4;
- the pins shall not turn when a torque of 0,4 N·m is applied, first in one direction for 1 min and then in the opposite direction for 1 min.

Small pieces may be broken off without causing rejection provided that the protection against electric shock is not affected.

Damage to the finish and small dents which do not reduce the creepage distances or clearances below the values specified in 27.1 are ignored.

24.4 The bases of surface-type socket-outlets are first fixed to a cylinder of rigid steel sheet, having a radius equal to 4,5 times the distance between fixing holes but, in any case, no less than 200 mm. The axes of the holes are in a plane perpendicular to the axis of the cylinder and parallel to the radius through the centre of the distance between the holes.

The fixing screws of the base are gradually tightened, the maximum torque applied being 0,5 N·m for screws having a thread diameter up to and including 3 mm and 1,2 N·m for screws having a larger thread diameter.

The bases of socket-outlets are then fixed in a similar manner to a flat steel sheet.

During and after the tests, the bases of socket-outlets shall show no damage impairing their further use.

24.5 The specimens are subjected to an impact test by means of apparatus as shown in Figure 20.

The apparatus, positioned on a pad of sponge rubber 40 mm thick, is placed together with the specimens in a freezer at a temperature of (-15 ± 2) °C, for at least 16 h.

At the end of this period, each specimen, in turn, is placed in the normal position of use as shown in Figure 20, and a mass is allowed to fall from a height of 100 mm. The falling mass is $(1\ 000 \pm 2)$ g.

After the test, the specimen shall not show any damage which impairs safety as required by Clause 4.

24.6 The specimens are subjected to a compression test as shown in Figure 8, the temperature of the pressure plate, of the base and of the specimens being (23 ± 2) °C and the force applied being 300 N.

The specimens are first placed in the position shown in Figure 8a, and the force is applied for 1 min. They are then placed in the position shown in Figure 8b, and again subjected to the force for 1 min.

The specimens are removed from the test apparatus and after 15 min they shall not show any damage which impairs safety as required by Clause 4.

24.7 Screwed glands are fitted with a cylindrical metal rod having a diameter, in millimetres, equal to the nearest whole number below the internal diameter, in millimetres, of the packing.

The glands are then tightened by means of a suitable spanner, the torque shown in Table 21 being applied for 1 min.

Table 21 – Torque test values for glands

Diameter of test rod mm	Torque N·m	
	Metal glands	Glands of moulded material
Up to and including 14	6,25	3,75
Above 14, up to and including 20	7,5	5,0
Above 20	10,0	7,5

After the test, the glands and the enclosures of the specimens shall not show any damage which impairs safety as required by Clause 4.

24.8 Shuttered socket-outlets shall have the shutter so designed that it withstands the mechanical force which may be expected in normal use, for example when a pin of a plug is inadvertently forced against the shutter of a socket-outlet entry hole.

Compliance is checked by the following tests, which are carried out on specimens which have been submitted to the test according to Clause 21, both with and without previous treatment as in 16.1.

One pin from a plug of the same system is applied for 1 min with a force of 40 N against the shutter of an entry hole in a direction perpendicular to the front surface of the socket-outlet.

For shutters provided as the only means to prevent single pole insertion, the force shall be 75 N instead of 40 N.

The pin shall not come in contact with live parts.

An electrical indicator with a voltage not less than 40 V and not more than 50 V is used to show contact with the relevant part.

After the test, the specimens shall not show any damage which impairs safety as required by Clause 4.

Small dents on the surface which do not adversely affect further use of the socket-outlet are ignored.

24.9 *This test is made on new specimens.*

The plug is placed on a rigid steel plate provided with holes suitable for the pins of the plug as shown as an example in Figure 21.

The distances between the centres of the holes (for example, d_1 and d_2) shall be the same as the distances between the centres of the circle circumscribed around the cross-sectional area of each pin in the standard sheet of the plug.

Each hole shall have a diameter equal to that of the circle that circumscribes the pin plus $(6 \pm 0,5)$ mm.

The plug is positioned on the steel plate in such a way that the centres of the circles circumscribing the pins coincide with the centres of the holes.

A pull P equal to the maximum withdrawal force as given in Table 16 is applied, in a smooth and continuous motion, for 1 min on each pin in turn, in the direction of the longitudinal axis of the pin.

The pull is applied within a heating cabinet at a temperature of (70 ± 2) °C, 1 h after the plug has been placed in the heating cabinet.

After the test, the plug is allowed to cool down to ambient temperature and it shall be verified that no pin has been displaced in the body of the plug by more than 1 mm.

24.10 *Barriers, between the space intended for the suspension means fixed to the mounting surface and the live parts, likely to be subjected to mechanical strain when the socket-outlet is suspended on a mounting surface, are tested as follows.*

A cylindrical steel rod, having a diameter of 3 mm and a hemispherical end with a radius of 1,5 mm, is pushed perpendicular to the supporting mounting surface, in the most unfavourable position, for 10 s against the barrier, the force being equal to 1,5 times the maximum plug withdrawal force (as specified in 22.2 and Table 16).

The rod shall not pierce the barrier.

24.11 *The socket-outlet, fitted with an appropriate flexible cable, is suspended on the mounting surface as in normal use by means of a cylindrical steel rod having the same dimensions as the rod described in 24.10, and a length sufficient to touch the rear of the barrier.*

A pull equal to the force prescribed in 23.2 for checking the flexible cable anchorage is applied, in the most unfavourable position, to the flexible cable for 10 s.

During the test, the socket-outlet means for suspension on a mounting surface shall not break in a way which allows live parts to become accessible to the standard test finger.

24.12 *The socket-outlet is suspended on the mounting surface as in normal use, using a round head screw with shank diameter of 3 mm, and is subjected to a pull test with the maximum withdrawal force specified, for the corresponding plug, in Table 16, applied in a smooth and continuous motion.*

The pull force is applied for 10 s perpendicular to the engagement face of the socket-outlet giving the greatest strain on the suspension means.

During the test, the socket-outlet means for suspension on a wall shall not break in a way which allows live parts to become accessible to the test probe B of IEC 61032.

Where more than one means of suspension exist, the tests of 24.10, 24.11 and 24.12 are carried out on each means of suspension.

24.13 *When checking the forces necessary to retain or remove covers, cover-plates or parts of them, the accessories are mounted as for normal use.*

Flush-type socket-outlets are fixed in appropriate mounting boxes, which are installed as for normal use so that the rims of the boxes are flush with the walls and covers or cover-plates, or parts of them, are fitted.

Plugs and socket-outlets for data centres intended to be fixed to a wall or a rack are fixed in a suitable manner so that the force can be applied to the cover, cover-plates or parts of them.

If the covers or cover-plates, or parts of them, are provided with locking means which can be operated without the aid of a tool, these means are unlocked.

For fixed socket-outlets, compliance is checked according to 24.13.1 and 24.13.2 (see 13.7.2).

For plugs and socket-outlets for data centres intended to be fixed to a wall or a rack compliance is checked according to 24.13.3.

24.13.1 Verification of the retention of covers or cover-plates

Forces are gradually applied perpendicular to the mounting surface, in such a way that the resulting force acting on the centre of the covers, cover-plates, or parts of them is

- 40 N for covers, cover-plates or parts of them complying with the tests of 24.16 and 24.17, or*
- 80 N for other covers, cover-plates or parts of them.*

The force is applied for 1 min. The covers or cover-plates shall not come off.

The test is then repeated on new specimens, the cover or cover-plate being fitted on the wall after a sheet of hard material, (1 ± 0,1) mm thick, has been fitted around the supporting frame as shown in Figure 22.

The sheet of hard material is used to simulate wallpaper and may consist of a number of pieces.

After the test, the specimens shall not show any damage which impairs safety as required by Clause 4.

24.13.2 Verification of the removal of covers or cover-plates

A force not exceeding 120 N is gradually applied, perpendicular to the mounting/supporting surfaces, to covers, cover-plates or parts of them by means of a hook placed in turn in each of the grooves, holes, spaces or the like provided for removing them.

The covers or cover-plates shall come off.

The test is made 10 times on each separable part, the fixing of which is not dependent on screws, the removal force being applied each time to the different grooves, holes or the like provided for removing the separable part, equally distributing as far as practicable the application points.

The test is then repeated on new specimens, the cover or cover-plate being fitted on the wall after a sheet of hard material, (1 ± 0,1) mm thick, has been fitted around the supporting frame, as shown in Figure 22.

After the test, the specimens shall not show any damage which impairs safety as required by Clause 4.

24.13.3 *For plugs and socket-outlets for data centres to be fixed to a wall or a rack, a force is gradually applied until 80 N is achieved and maintained for 1 min, to covers, cover-plates or parts of them while the other parts of the accessory are fixed.*

The test shall be carried out in the most unfavourable conditions.

During the test the covers, cover-plates or parts of them shall not come off.

The test is then repeated with a force of 120 N.

For rewirable plugs and rewirable socket-outlets for data centres intended to be fixed to a wall or a rack, the cover, the cover-plate or parts of them may come off during the test but the specimen shall not show any damage which impairs safety as required by Clause 4.

For non-rewirable, non-moulded-on accessories, during the test, the cover, the cover-plate or parts of them may come off but the accessories shall be permanently useless (see 14.1).

24.14 *The test is made as described in 24.13, but applying, for 24.13.1, the following forces:*

- 10 N for covers or cover-plates complying with the tests of 24.16 and 24.17;
- 20 N for other covers or cover-plates.

24.15 *The test is made as described in 24.13, but applying, for 24.13.1, the force of 10 N for all covers or cover-plates.*

24.16 *The gauge shown in Figure 23 is pushed toward each side of each cover or cover-plate which is fixed without screws on a mounting or supporting surface, as shown in Figure 24. With face B resting on the mounting/supporting surface, and face A perpendicular to it, the gauge is applied at right angles to each side under test.*

In the case of a cover or cover-plate fixed without screws to another cover or cover-plate, or to a mounting box having the same outline dimensions, face B of the gauge shall be placed at the same level as the junction. The outline of the cover or cover-plate shall not exceed the outline of the supporting surface.

The distances between face C of the gauge and the outline of the side under test, measured parallel to face B, shall not decrease (with the exception of grooves, holes, reverse tapers or the like, placed at a distance less than 7 mm from a plane including face B and complying with the test of 24.17) when measurements are repeated, starting from point X in the direction of the arrow Y (see Figure 25).

24.17 *A gauge according to Figure 26, applied with a force of 1 N, shall not enter more than 1,0 mm from the upper part of any groove, hole, reverse taper or the like, when the gauge is applied parallel to the mounting/supporting surface and perpendicular to the part under test, as shown in Figure 27.*

Verification as to whether, according to Figure 26, the gauge has entered by more than 1,0 mm is made with reference to a surface perpendicular to face B and including the upper part of the outline of the grooves, holes, reverse tapers or the like.

24.18 *The shrouds of plugs are subjected to a compression test at an ambient temperature of (25 ± 5) °C in apparatus similar to that shown in Figure 29.*

The apparatus comprises two steel jaws, having a cylindrical face of 25 mm radius, a width of 15 mm and a length of 50 mm. The length of 50 mm can be increased, depending on the size of the accessory to be tested.

The corners are rounded with a radius of 2,5 mm.

The specimens are clamped in such a way that the front face of the jaws coincides with the front face of the shroud.

The force applied through the jaws is (20 ± 2) N.

After 1 min, and while the shrouds are still under pressure, the dimensions shall comply with the appropriate standard sheet.

The test is repeated with the specimen rotated 90°.

25 Resistance to heat

25.1 Accessories and surface-type mounting boxes shall be resistant to heat as specified in Table 22.

Table 22 – Resistance to heat of different types or parts of accessories

Specimen		Test according to 25.2	Test according to 25.3	Test according to 25.4	Test according to 25.5
A	surface-mounting boxes, separable covers, separable cover-plates and separable frames with the exception of parts of the front surface zone of thermoplastic material of 2 mm width surrounding the phase and neutral pin entry holes	–	–	X	–
B	plugs with the exception of the parts covered by A	X	X	X	X
C	plugs made of natural or synthetic rubber or a mixture of both or PVC	X	X	–	X
D	socket-outlets with the exception of the parts covered by A	X	X	X	–
E	socket-outlets made of natural or synthetic rubber or a mixture of both	X	X	–	–
X: test applicable –: test not applicable					

Parts intended for decorative purposes, such as certain lids, are not submitted to any of these tests.

25.2 The specimens are kept for 1 h in a heating cabinet at a temperature of (100 ± 2) °C.

During the test, they shall not undergo any change impairing their further use. Sealing compound, if any, shall not flow to such an extent that live parts are exposed.

After the test, the specimens are then allowed to cool down to approximately room temperature. There shall be no access to live parts which are normally not accessible when the specimens are mounted as in normal use, even if probe B of IEC 61032 is applied with a force not exceeding 5 N.

After the test, markings shall still be legible.

Discoloration, blisters or slight displacement of the sealing compound is disregarded, provided that safety is not impaired as required by Clause 4.

25.3 Parts of insulating material necessary to retain current-carrying parts and parts of the earthing circuit in position, as well as parts of the front surface zone of thermoplastic material, 2 mm wide, surrounding the phase and neutral pin entry holes of socket-outlets, shall be subjected to a ball-pressure test by means of the apparatus shown in Figure 28, except that the insulating parts necessary to retain the earthing terminals in position in a box shall be tested as specified in 25.4.

When it is not possible to carry out the test on the specimens, the test shall be carried out on a piece at least 2 mm thick which is cut from the specimen. If this is not possible, no more than four layers, each cut from the same specimen, may be used, in which case the total thickness of the layers shall be not less than 2,5 mm.

The part under test shall be placed on a steel plate at least 3 mm thick and in direct contact with it.

The surface of the part to be tested is placed in the horizontal position and the hemispherical tip of the test equipment is pressed against the surface with a force of 20 N.

The test load and the supporting means shall be placed within the heating cabinet for a sufficient time to ensure that they have attained the stabilized testing temperature before the test commences.

The test is made in a heating cabinet at a temperature of (125 ± 2) °C.

After 1 h the ball shall be removed from the specimen, which is then immersed within 10 s in cold water for cooling down to approximately room temperature.

The diameter of the impression caused by the ball is measured and shall not exceed 2 mm.

25.4 *Parts of insulating material not necessary to retain current-carrying parts and parts of the earthing circuit in position, even though they are in contact with them, are subjected to a ball-pressure test in accordance with 25.3, but the test is made at a temperature of (70 ± 2) °C, or (40 ± 2) °C plus the highest temperature rise determined for the relevant part during the test of Clause 19, whichever is the higher.*

25.5 *The specimens are subjected to a compression test by means of apparatus as shown in Figure 29, the test being made in a heating cabinet at a temperature of (80 ± 2) °C.*

The apparatus comprises two steel jaws, having a cylindrical face of 25 mm radius, a width of 15 mm and a length of 50 mm. The length of 50 mm can be increased, depending on the size of the accessory to be tested.

The corners are rounded with a radius of 2,5 mm.

The specimen is clamped between the jaws in such a way that these press against it in the area where it is gripped in normal use, the centre line of the jaws coinciding as nearly as possible with the centre of this area. The force applied through the jaws is 20 N.

After 1 h, the jaws are removed and the specimens shall not show any damage which impairs safety as required by Clause 4.

26 Screws, current-carrying parts and connections

26.1 Connections, electrical or mechanical, shall withstand the mechanical stresses occurring in normal use.

Mechanical connections to be used during installation of accessories may be made using thread-forming screws or thread-cutting screws only when the screws are supplied together with the piece in which they are intended to be inserted. In addition, thread-cutting screws intended to be used during installation shall be captive with the relevant part of the accessory.

Screws or nuts which transmit contact pressure shall be in engagement with a metal thread.

Compliance is checked by inspection and, for screws and nuts transmitting contact pressure or which are operated when connecting up the accessory, by the following test.

NOTE The requirements for the verification of terminals are given in Clause 12.

The screws or nuts are tightened and loosened

- *10 times for screws in engagement with a thread of insulating material and for screws of insulating material,*
- *five times for all other cases.*

Screws or nuts in engagement with a thread of insulating material and screws of insulating material are completely removed and reinserted each time.

The test is made by means of a suitable screwdriver or a suitable tool, applying a torque as specified in Table 4.

During the test, no damage impairing the further use of the screwed connections shall occur, such as breakage of screws or damage to the head slots (rendering the use of an appropriate screwdriver impossible), threads, washers or stirrups.

Screws or nuts which are operated when connecting accessories include screws for fixing covers or cover plates, etc., but not connecting means for screwed conduits and screws for fixing the base of a fixed socket-outlet.

The shape of the blade of the screwdriver used for the test shall match the head of the screw to be tested. The screws and nuts shall be tightened in a smooth and continuous motion. Damage to covers is ignored.

Screwed connections are considered as partially checked by the tests of Clauses 21 and 24.

26.2 For screws in engagement with a thread of insulating material which are operated when mounting the accessory during installation, their correct introduction into the screw hole or nut shall be ensured.

Compliance is checked by inspection and by manual test.

The requirement with regard to correct introduction is met if introduction of the screw in a slanting manner is prevented, for example by guiding the screw by the part to be fixed, by a recess in the female thread or by the use of a screw with the leading thread removed.

26.3 Electrical connections shall be designed in such a way that contact pressure is not transmitted through insulating material other than ceramic, pure mica or other material with characteristics no less suitable, unless there is sufficient resiliency in the metallic parts to compensate for any possible shrinkage or yielding of the insulating material.

Compliance is checked by inspection and, for the last requirement, by a test which is under consideration.

26.4 Screws and rivets, which serve as electrical as well as mechanical connections, shall be locked against loosening and/or turning.

Compliance is checked by inspection and by manual test.

Spring washers may provide satisfactory locking.

For rivets, a non-circular shank or an appropriate notch may be sufficient.

Sealing compound which softens on heating provides satisfactory locking only for screw connections not subjected to torsion in normal use.

26.5 Current-carrying parts, including those of terminals (as well as earthing terminals), shall be of metal having, under the conditions occurring in the accessory, mechanical strength, electrical conductivity and resistance to corrosion adequate for their intended use. Metals showing a difference of electromechanical potential greater than 0,030 V with respect to each other shall not be used in contact with each other. Under moist conditions, metals showing a difference of electromechanical potential greater than 0,030 V with respect to each other shall not be used.

Compliance is checked by inspection and, if necessary, by chemical analysis.

The requirement of 26.5 is deemed to be met if one of the following suitable metals is used within the permissible temperature range and under normal conditions of chemical pollution:

- *copper, with or without electroplated coating of silver or nickel;*
- *an alloy containing at least 58 % copper for parts made from cold-rolled sheet or at least 50 % copper for other parts, with or without electroplated coating of silver or nickel;*
- *stainless steel containing at least 13 % chromium and not more than 0,09 % carbon;*
- *steel provided with an electroplated coating of nickel and chromium according to ISO 1456, the coating having a thickness of at least 20 μm , service-condition number 2 according to ISO 1456, for accessories classified IP code IPX0. Current-carrying parts which may be subjected to mechanical wear shall not be made of steel provided with an electroplated coating.*

The requirement of 26.5 does not apply to screws, nuts, washers, clamping plates and similar parts of terminals.

26.6 Contacts which are subjected to a sliding action in normal use shall be of a metal resistant to corrosion.

Compliance with the requirements of 26.5 and 26.6 is checked by inspection and, in case of doubt, by chemical analysis.

26.7 Thread-forming screws and thread-cutting screws shall not be used for the connection of current-carrying parts.

Thread-forming screws and thread-cutting screws may be used to provide earthing continuity, provided that it is not necessary to disturb the connection in normal use and that at least two screws are used for each connection.

Compliance is checked by inspection.

27 Creepage distances, clearances and distances through sealing compound

27.1 Creepage distances, clearances and distances through sealing compound shall be not less than the values shown in Table 23.

Socket-outlets for assemblies are tested with the metal frame, if any, placed in the most unfavourable positions if this frame, acting as a support, is movable.

Table 23 – Creepage distances, clearances and distances through insulating sealing compound

Description	mm
<i>Creepage distance:</i>	
1 between live parts of different polarity;	4
2 between live parts and	
– accessible surface of parts of insulating material,	4
– earthed metal parts including parts of earthing circuit,	4
– metal frames supporting the base of flush-type socket-outlets,	4
– screws or devices for fixing bases, covers or cover-plates of fixed socket-outlets,	4
– external assembly screws, other than screws which are on the engagement face of plugs and are isolated from the earthing circuit;	4
3 between pins of plugs and metal parts connected to them, when fully engaged, and a socket-outlet of the same system having accessible unearthed metal parts ^a , made according to the most unfavourable construction ^b ;	8
4 between the accessible unearthed metal parts ^a of a socket-outlet and a fully engaged plug of the same system having pins and metal parts connected to them made according to the most unfavourable construction ^b ;	8
5 between live parts of a socket-outlet (without a plug) or of a plug and their accessible unearthed or functional earthed metal parts ^a .	8
<i>Clearance:</i>	
6 between live parts of different polarity;	4
7 between live parts and	4
– accessible surface of parts of insulating material,	4
– earthed metal parts not mentioned under items 8 and 9 including parts of earthing circuit,	4
– metal frames supporting the base of flush-type socket-outlets,	4
– screws or devices for fixing bases, covers or cover-plates of fixed socket-outlets,	4
– external assembly screws, other than screws which are on the engagement face of plugs and are isolated from the earthing circuit;	4
8 between live parts and	
– metal boxes intended to be earthed with the socket-outlet in the most unfavourable position,	4
– unearthed metal boxes, without insulating lining with the socket-outlet in the most unfavourable position,	8
– accessible unearthed or functional earthed metal parts ^a of socket-outlets and plugs;	8
9 between live parts and the surfaces on which the base of a socket-outlet for surface mounting is mounted;	8
10 between live parts and the bottom of any conductor recess, if any, in the base of a socket-outlet for surface mounting.	4
<i>Distance through insulating sealing compound:</i>	
11 between live parts covered with at least 2 mm of sealing compound and the surface on which the base of a socket-outlet for surface mounting is mounted;	4
12 between live parts covered with at least 2 mm of sealing compound and the bottom of any conductor recess, if any, in the base of a socket-outlet for surface mounting.	4
^a With the exception of screws and the like.	
^b The most unfavourable construction may be checked by means of a gauge which is based on the standard sheets relevant to the system concerned.	

Compliance is checked by measurement.

For rewirable accessories, the measurements are made on the specimen fitted with conductors of the largest nominal cross-sectional area specified in Table 1 and also without conductors.

The conductor shall be inserted into the terminal and connected in such a way that the core insulation touches the metal part of the clamping unit or, where the core insulation is prevented by construction from touching the metal part, the outside of the obstruction.

For non-rewirable accessories, the measurements are made on the specimen as delivered.

Socket-outlets are checked when in engagement with a plug and also without a plug.

Distances through slots or openings in external parts of insulating material are measured using a metal foil in contact with the accessible surface other than the engagement face of plugs. The foil is pushed into corners and the like by means of the test probe 11 of IEC 61032, but is not pressed into openings.

For surface-type socket-outlets classified IP20 according to IEC 60529, the most unfavourable conduit or cable is introduced for a distance of 1 mm into the socket-outlet in accordance with 13.19. If the metal frame supporting the base of a flush-type socket-outlet is movable, this frame is placed in the most unfavourable position.

The contribution to the creepage distance of any groove less than 1 mm wide is limited to its width.

Any air-gap less than 1 mm wide is ignored in computing the total clearance.

The surface on which the base of a socket-outlet for surface mounting is mounted includes any surface in contact with the base when the socket-outlet is installed. If the base is provided with a metal plate at the back, this plate is not regarded as the mounting surface.

27.2 Insulating sealing compound shall not protrude above the edge of the cavity in which it is contained.

27.3 Surface-type socket-outlets shall not have bare current-carrying strips at the back.

Compliance with the requirements of 27.2 and 27.3 is checked by inspection.

28 Resistance of insulating material to abnormal heat and to fire

Parts of insulating material which might be exposed to thermal stresses due to electric effects, and the deterioration of which might impair the safety of the accessory, shall not be unduly affected by abnormal heat and by fire.

For the purpose of this test, socket-outlets for assemblies are considered to be fixed socket-outlets.

Compliance is checked by the glow-wire flammability test method for end products according to IEC 60695-2-11 under the following conditions:

- for parts made of insulating material necessary to retain current-carrying parts and parts of the earthing circuit of socket-outlet in position, by the test made at 850 °C, with the exception of parts of insulating material needed to retain the earth terminal in position in a box, which shall be tested at a temperature of 650 °C;*
- for parts of insulating material necessary to retain current-carrying parts, and parts of the earthing circuit of plugs in position, by the test made at a temperature of 750 °C;*
- for parts of insulating material not necessary to retain current-carrying parts and parts of the earthing circuit in position, even though they are in contact with them, by the test made at a temperature of 650 °C.*

A current-carrying part or a part of the earthing circuit retained by mechanical means is considered to be retained in position. The use of grease or the like is not considered to be mechanical means.

External conductors cannot be considered as retaining the current-carrying parts.

In case of doubt, to determine whether an insulating material is necessary to retain current-carrying parts and parts of the earthing circuit in position, the device is examined without conductors while held in positions most likely to cause displacement of the current-carrying parts or parts of the earthing circuit with the insulating material in question removed.

If the tests specified have to be made at more than one place on the same specimen, ensure that any deterioration caused by previous tests does not affect the result of the test to be made.

The tests are not made on parts of ceramic material.

If possible, the specimen should be a complete accessory. If the test cannot be made on a complete accessory, a suitable part may be cut from it for the purpose of the test.

The test is made on one specimen.

The test is made by applying the glow-wire once.

In case of doubt, the test shall be repeated on two further specimens.

The specimen shall be positioned during the test in the most unfavourable position of its intended use (with the surface tested in a vertical position).

The tip of the glow-wire shall be applied to the specified surface of the specimen taking into account the conditions of the intended use under which a heated or glowing element may come into contact with the specimen.

The specimen is regarded as having passed the glow-wire flammability test method as given in IEC 60695-2-11.

If the material to be tested is not accessible due to the presence of moulded-on material the moulded-on material shall be removed to gain access. Alternatively, the manufacturer may provide the product as separate components and drawings to allow material retaining in position the current carrying parts to be tested.

29 Resistance to rusting

Ferrous parts, including covers and surface-mounting boxes, shall be adequately protected against rusting.

Compliance is checked by the following test.

All grease is removed from the parts to be tested, using a suitable degreasing agent.

The parts are then immersed for 10 min in a 10 % solution of ammonium chloride in water at a temperature of (20 ± 5) °C.

Without drying, but after shaking off any drops, the parts are placed for 10 min in a box containing air saturated with moisture at a temperature of (20 ± 5) °C.

After the parts have been dried for 10 min in a heating cabinet at a temperature of $(100 \pm 5) ^\circ\text{C}$, their surfaces shall show no signs of rust.

Traces of rust on sharp edges and any yellowish film removable by rubbing are ignored.

For small springs and the like, and for inaccessible parts exposed to abrasion, a layer of grease may provide sufficient protection against rusting. Such parts are subjected to the test only if there is doubt about the effectiveness of the grease film, and the test is then made without previous removal of the grease.

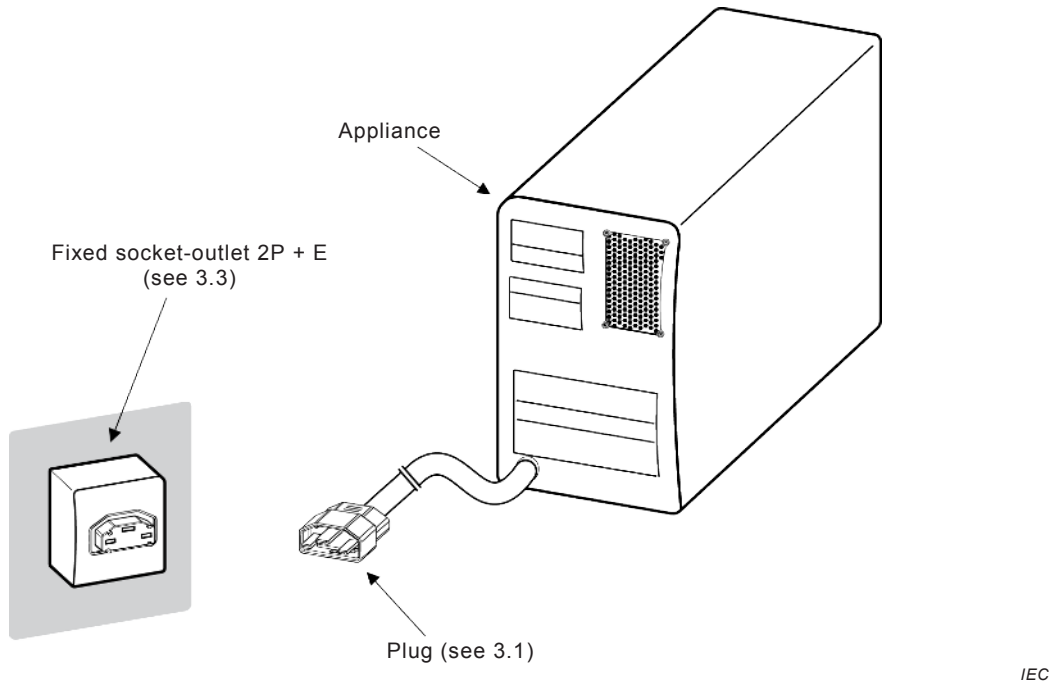

Figure 1a – Diagram showing various accessories and their use

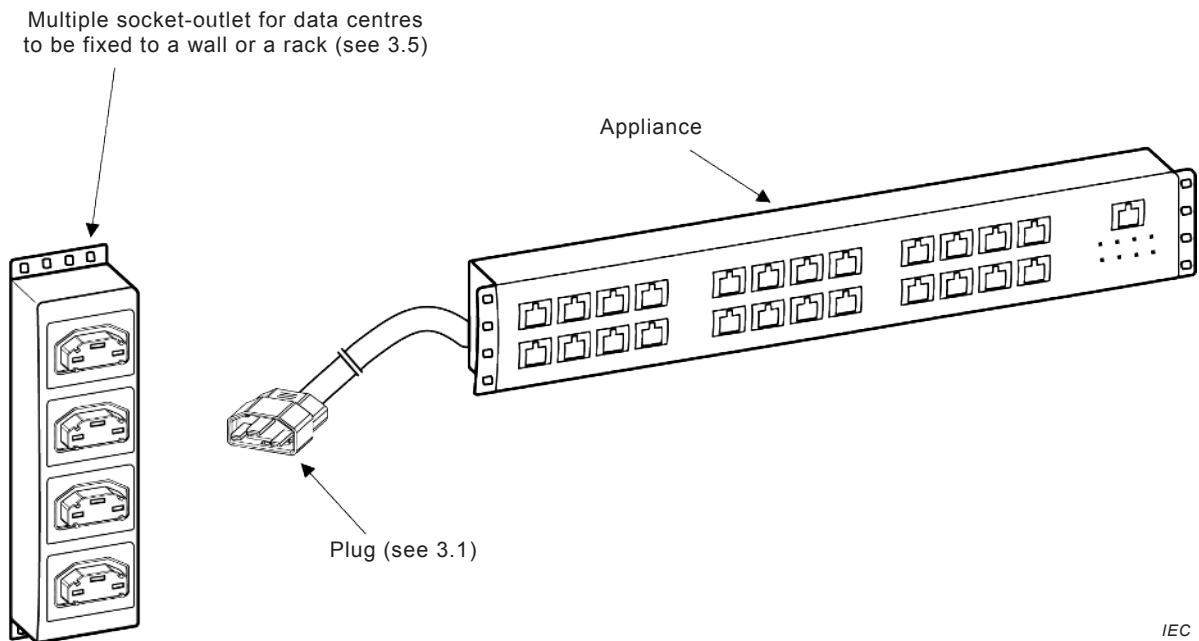
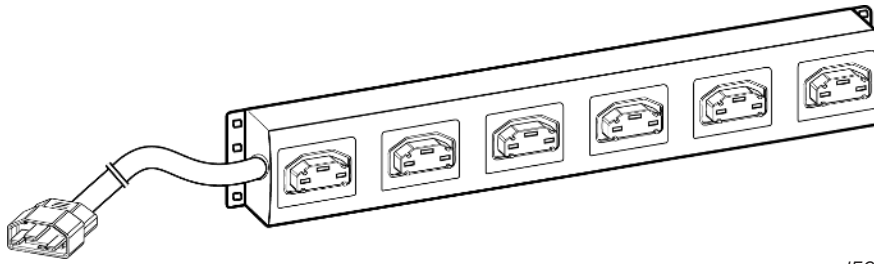
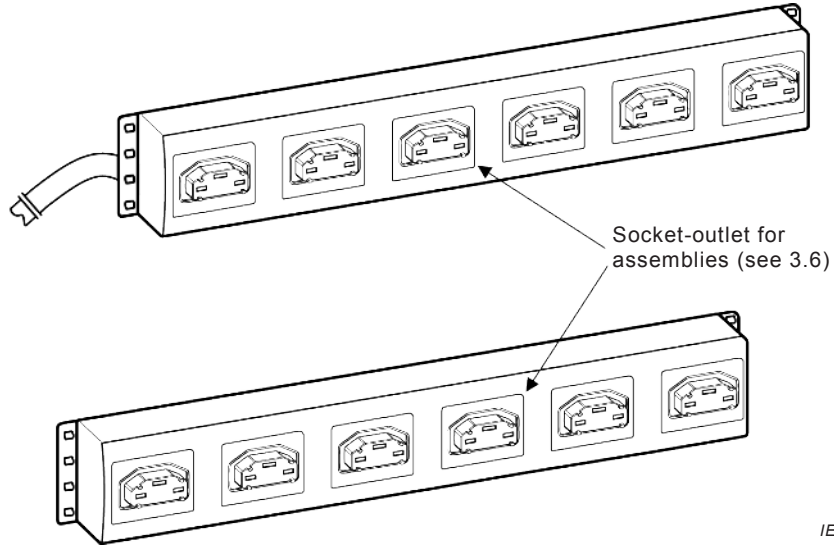

Figure 1b – Diagram showing various accessories and their use



IEC

Figure 1c – Cord extension set for data centres to be fixed to a wall or a rack



IEC

Figure 1d – Multiple socket-outlet for data centres to be fixed to a wall or a rack

Figure 1 – Examples of accessories

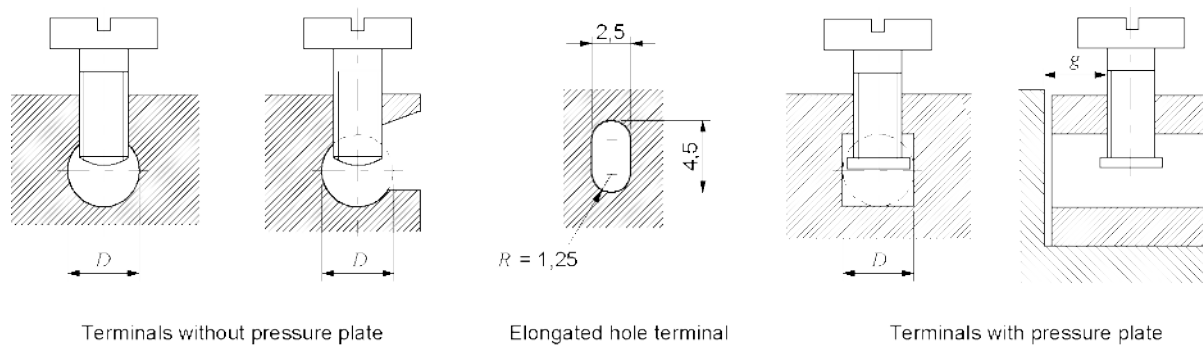

IEC

Dimensions in millimetres

Cross-section of conductor accepted by the terminal mm ²	Minimum diameter <i>D</i> (or minimum dimensions) of conductor space mm	Minimum distance <i>g</i> between clamping screw and end of conductor when fully inserted mm		Torque N·m					
				1 ^a		2 ^a		3 ^a	
				One screw	Two screws	One screw	Two screws	One screw	Two screws
Up to 1,5 or Up to AWG 16	2,5	1,5	1,5	0,2	0,2	0,4	0,4	0,4	0,4

^a The values specified apply to screws covered by the corresponding columns in Table 4.

The part of the terminal containing the threaded hole and the part of the terminal against which the conductor is clamped by the screw may be two separate parts, as in the case of terminals provided with a stirrup.

The shape of the conductor space may differ from those shown, provided that a circle with a diameter equal to the minimum specified for *D* or the minimum outline specified for the elongated hole accepting cross-sections of conductors up to 2,5 mm² can be inscribed.

Figure 2 – Pillar terminals

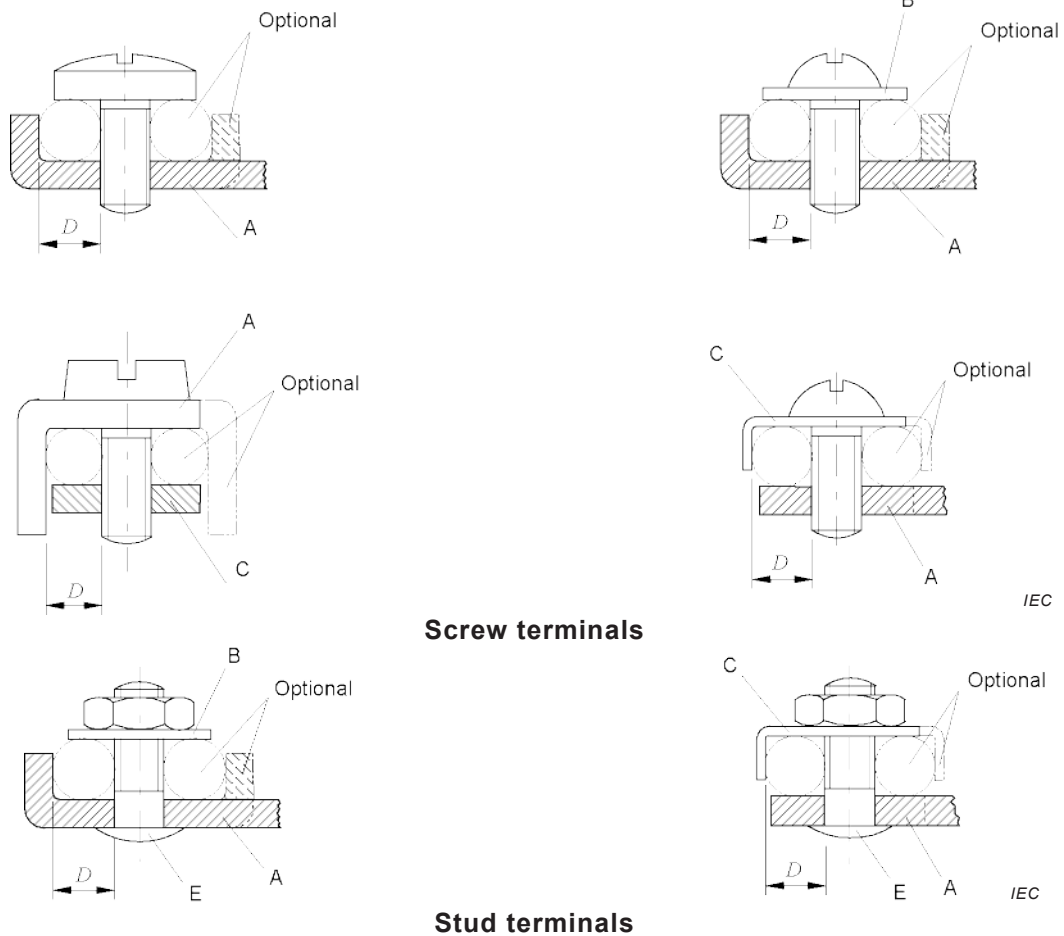

Screw terminals

Stud terminals

Figure 3a – Screw/stud not requiring washer or clamping plate

Figure 3b – Screw/stud requiring washer, clamping plate or anti-spread device

Key

- A Fixed part
- B Washer or clamping plate
- C Anti-spread device
- D Conductor space
- E Stud

Cross-section of conductor accepted by the terminal mm ²	Minimum diameter D of conductor space mm	Torque	
		3 ^a	
		One screw or stud	Two screws or studs
Up to 1,5 or Up to AWG 16	1,7	0,5	–

^a The values specified apply to the screws covered by the corresponding columns in Table 4.

The part which retains the conductor in position may be of insulating material provided the pressure necessary to clamp the conductor is not transmitted through the insulating material.

The second optional space for the terminal accepting cross-section of conductors up to 2,5 mm² may be used for the connection of the second conductor when it is required to connect two 2,5 mm² conductors.

Figure 3 – Screw terminals and stud terminals

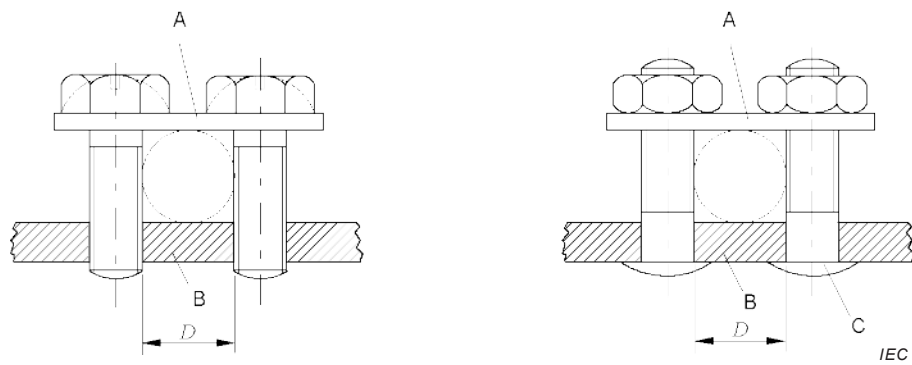

Key

- A Saddle
- B Fixed part
- C Stud
- D Conductor space

Cross-section of conductor accepted by the terminal mm ²	Minimum diameter <i>D</i> of conductor space mm	Torque N·m
Up to 4 or Up to AWG 12	3,0	0,5

The shape of the conductor space may differ from that shown in the figure, provided that a circle with a diameter equal to the minimum value specified for *D* can be inscribed.

The shape of the upper and lower faces of the saddle may have a different shape to accommodate conductors of either small or large cross-sectional areas by inverting the saddle.

Figure 4 – Saddle terminals

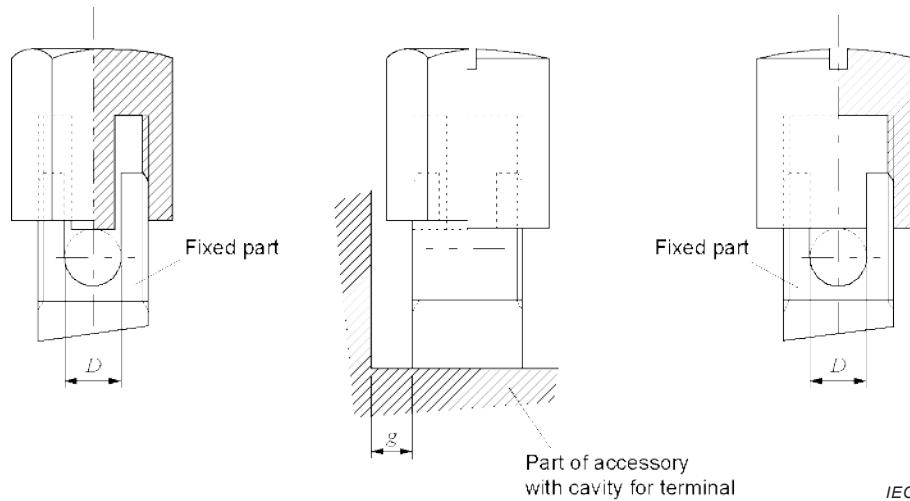

Cross-section of conductor accepted by the terminal	Minimum diameter D of conductor space ^a	Minimum distance g between fixed part and end of conductor when fully inserted
mm ²	mm	mm
Up to 1,5 or Up to AWG 16	1,7	1,5

^a The bottom of the conductor space shall be slightly rounded in order to obtain a reliable connection.

NOTE The value of the torque to be applied is that specified in column 2 or 3 of Table 4 as appropriate.

Figure 5 – Mantle terminals

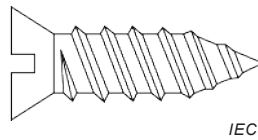

Figure 6 – Example of thread-forming screw

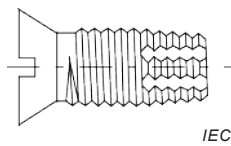

Figure 7 – Example of thread-cutting screw

Dimensions in millimetres

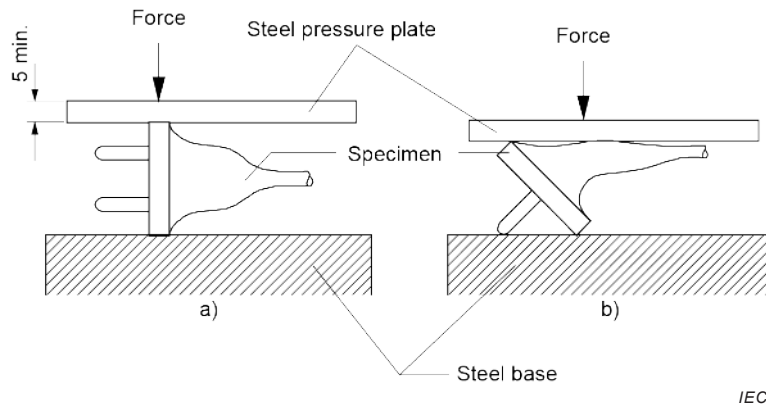
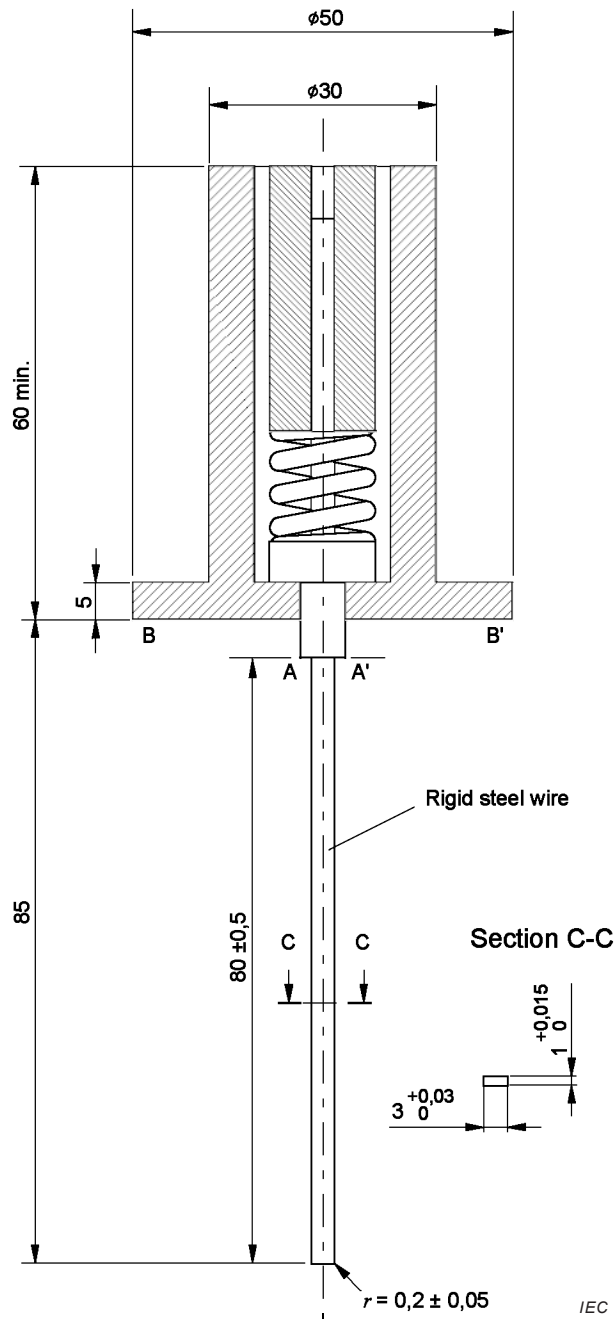

Figure 8 – Arrangement for compression test of 10.2 and 24.6

Dimensions in millimetres



To calibrate the gauge, a push force of 20 N is applied on the rigid steel wire in the direction of its axis: the characteristics of the gauge internal spring shall be such that the surface A–A' is brought practically to the same level as the surface B–B' when this force is applied.

Figure 9 – Gauge for checking non-accessibility of live parts, through shutters

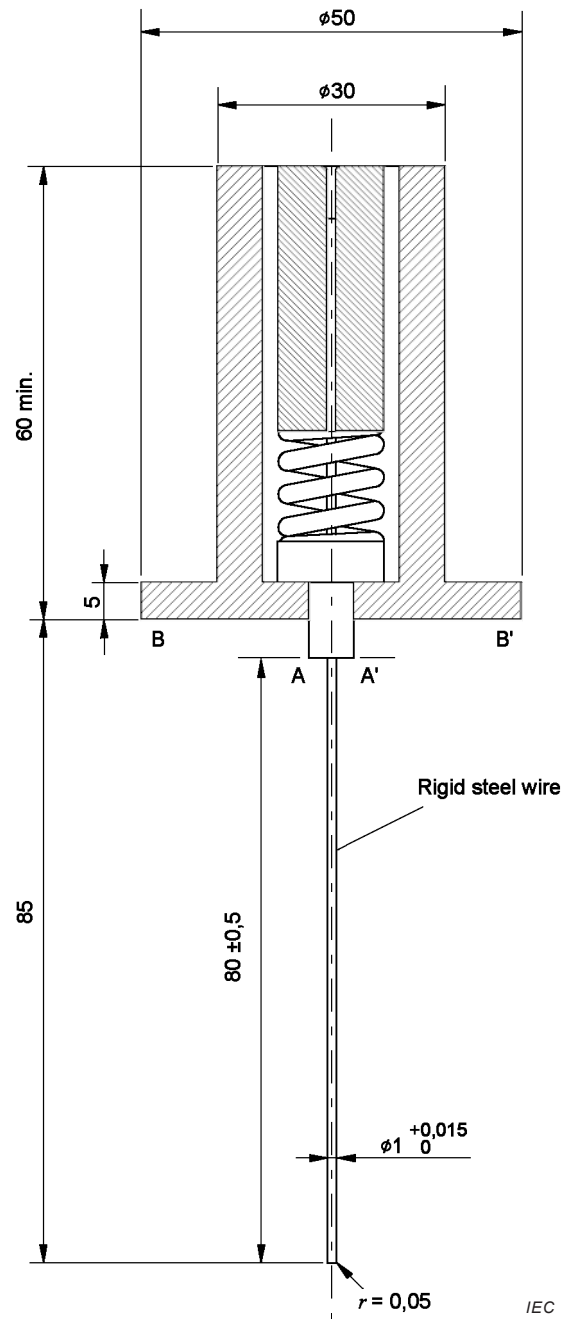

To calibrate the gauge, a push force of 1 N is applied on the rigid steel wire in the direction of its axis: the characteristics of the gauge internal spring shall be such that the surface A–A' is brought practically to the same level as the surface B–B' when this force is applied.

Figure 10 – Gauge for checking non-accessibility of live parts, through shutters, and of live parts of socket-outlets with increased protection

Dimensions in millimetres

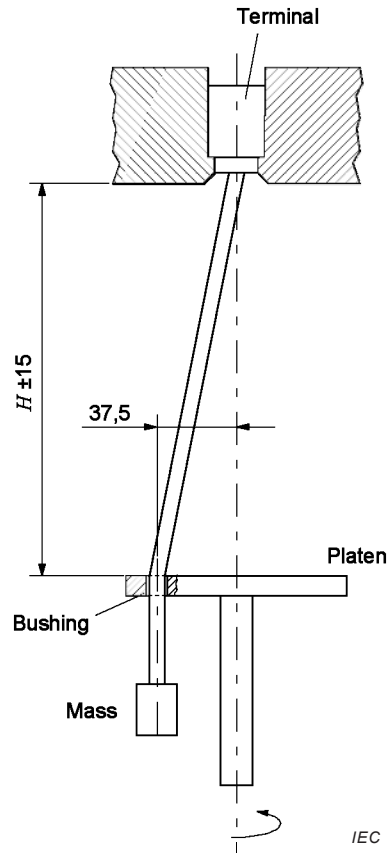

The bushing hole should be made in a way which ensures that the force extended to the cable is pure pulling force and that the transmission of any torque to the connection in the clamping means is avoided.

Figure 11 – Arrangement for checking damage to conductors

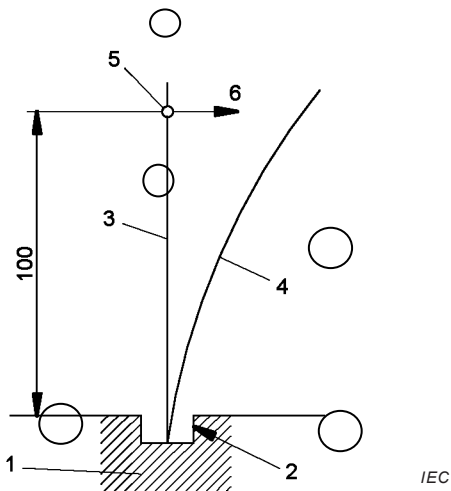
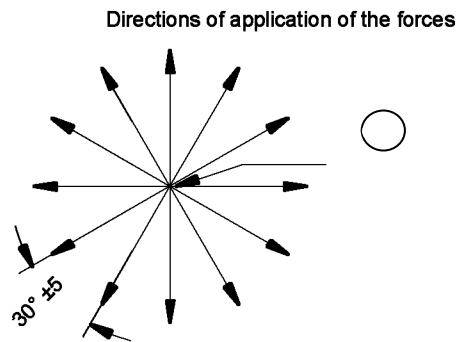

Figure 12a – Principle of the test apparatus for deflection on screwless terminals

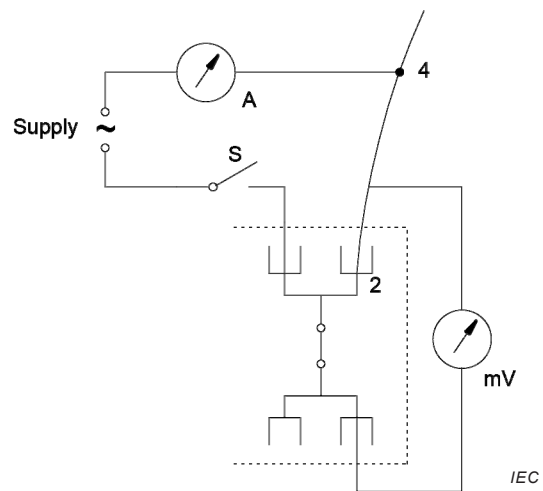
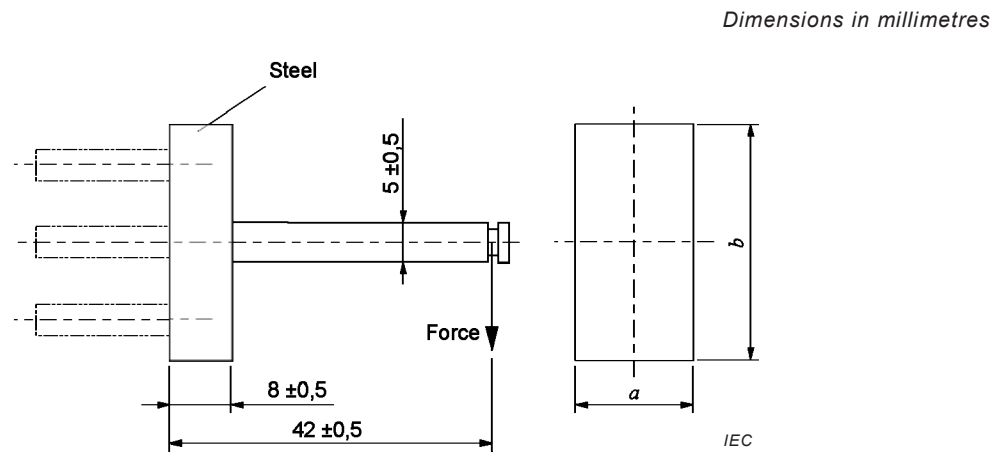

Figure 12b – Example of test arrangement to measure the voltage drop during deflection test on screwless terminals

Key

- A Ammeter
- mV Millivoltmeter
- S Switch
- 1 Specimen
- 2 Clamping unit under test
- 3 Test conductor
- 4 Test conductor, deflected
- 5 Point of application of the force for deflecting the conductor
- 6 Deflection force (perpendicular to the straight conductor)

Figure 12 – Information for deflection test



NOTE 1 The dimensions a and b are chosen according to the appropriate standard sheets.

NOTE 2 Dimensions and arrangement of pins are in compliance with standard sheets.

Figure 13 – Device for checking the resistance to lateral strain

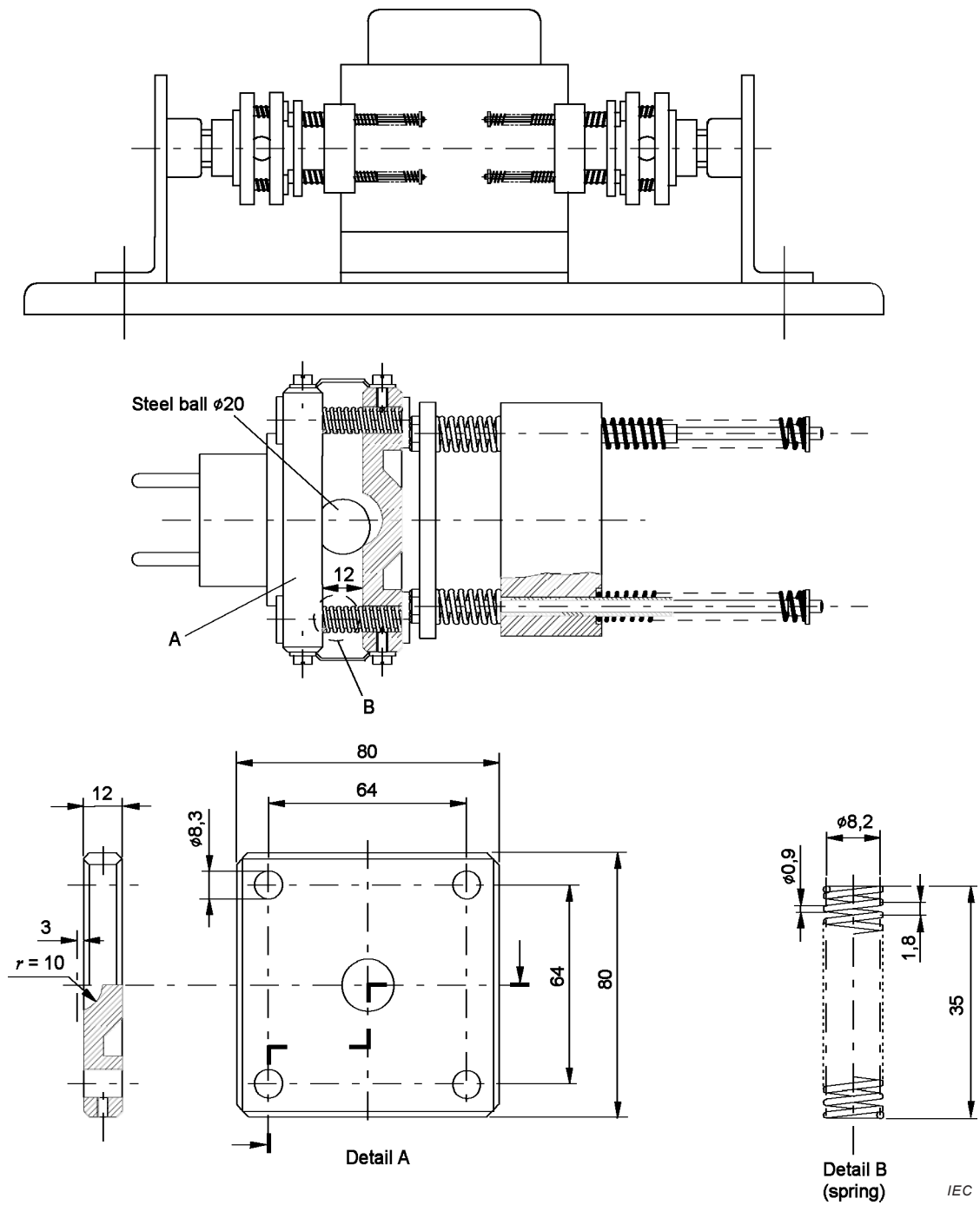
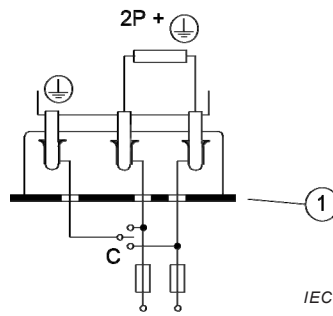

Figure 14 – Example of apparatus for breaking capacity and normal operation test



Key

1 Metal support

C Switch

Figure 15 – Circuit diagram for breaking capacity and normal operation tests

Dimensions in millimetres

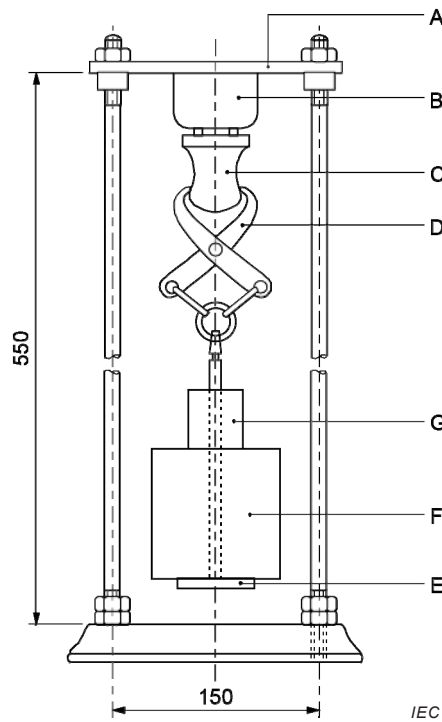

Key

A Mounting plate

B Specimen

C Test plug

D Clamp

E Carrier

F Principal mass

G Supplementary mass

Figure 16 – Apparatus for verification of maximum withdrawal force

Dimensions in millimetres

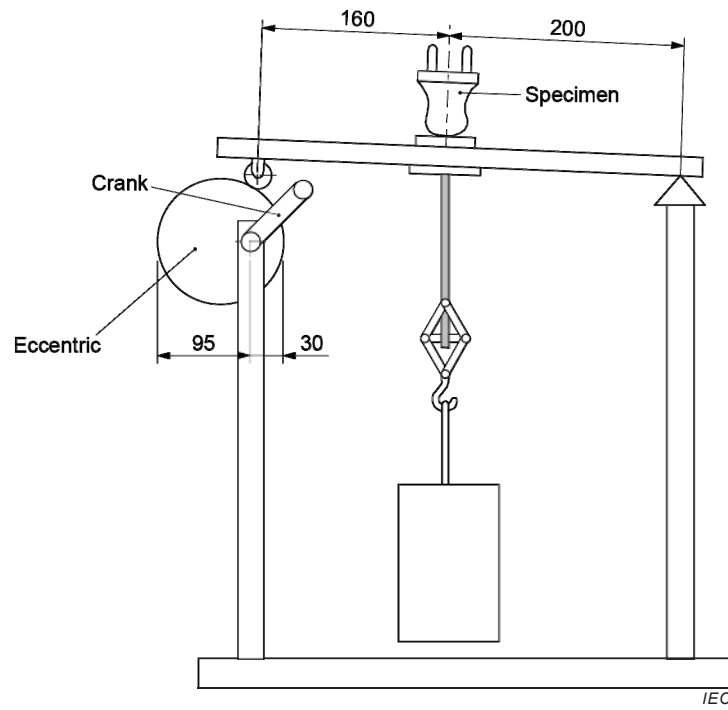
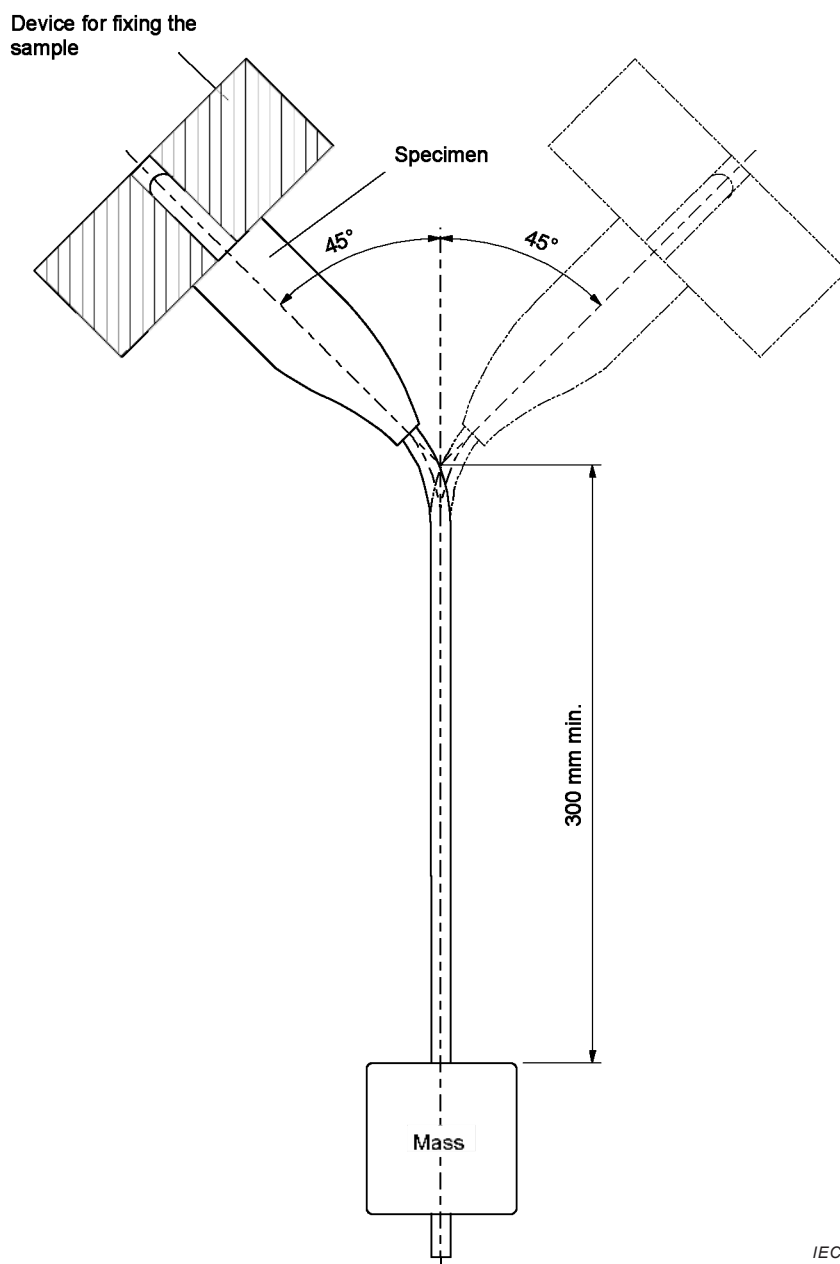
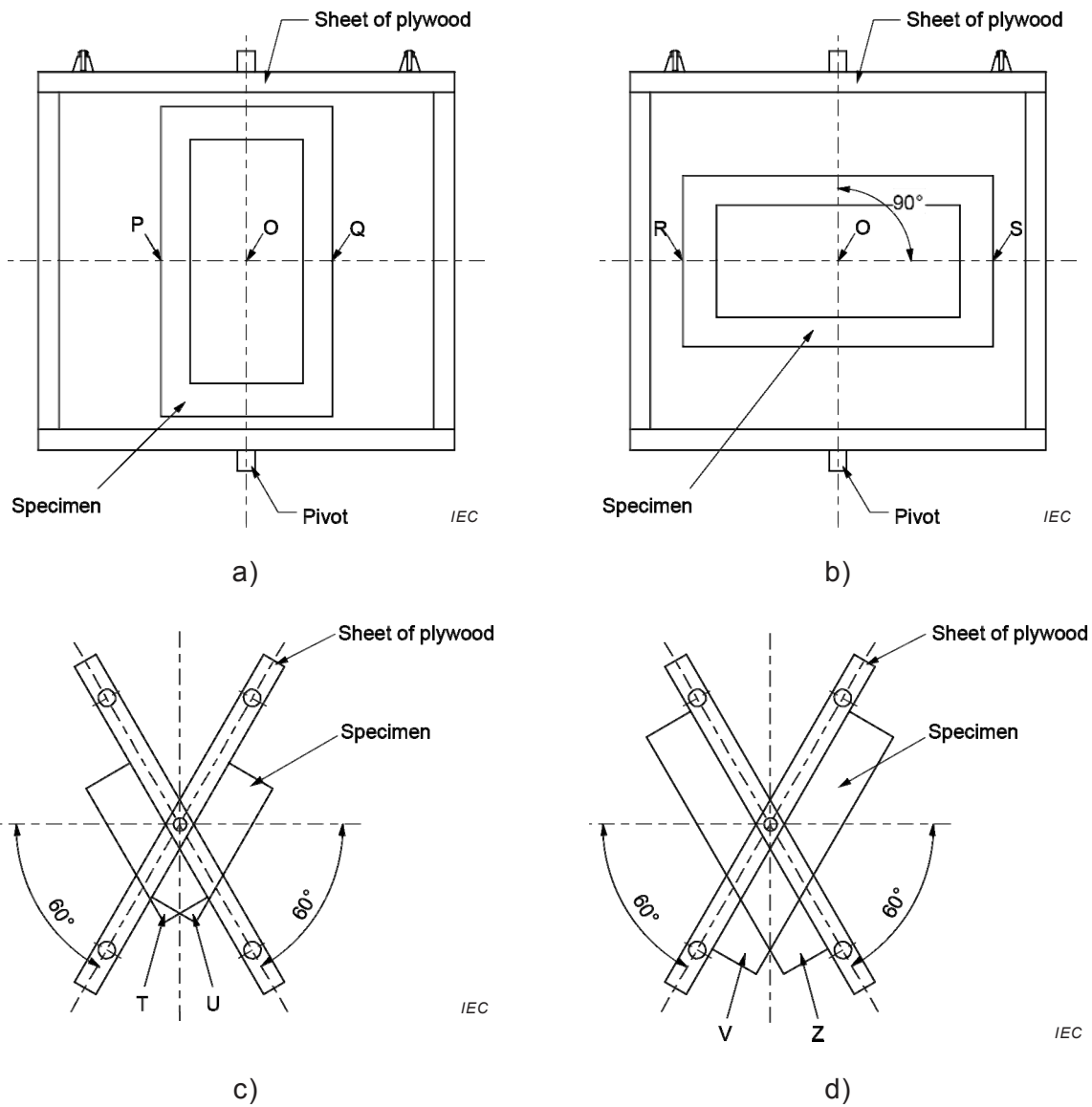

Figure 17 – Apparatus for testing cord retention



An adjustment of the different supports for the accessories by means of a threaded spindle shall be provided according to the explanation in 23.4.

Figure 18 – Apparatus for flexing test



Application of the blows			
Sketch	Total number of blows	Points of application	Parts to be tested
a)	3	One at the centre One between O and P ^a One between O and Q ^a	A
b)	2	One between O and R ^a One between O and S ^a	A
c)	2	One on the surface T ^a One on the surface U ^a	B, C and D
d)	2	One on the surface V ^a One on the surface Z ^a	B, C and D

^a The blow is applied to the most unfavourable point.

Figure 19 – Sketches showing the application of the blows according to Table 20

Dimensions in millimetres

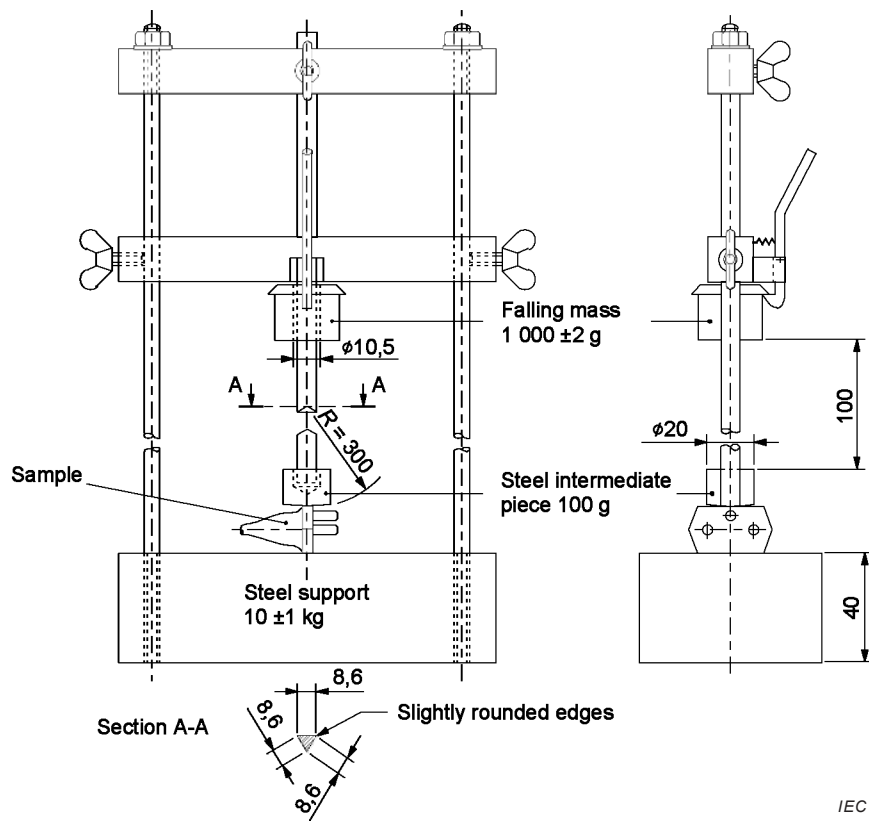
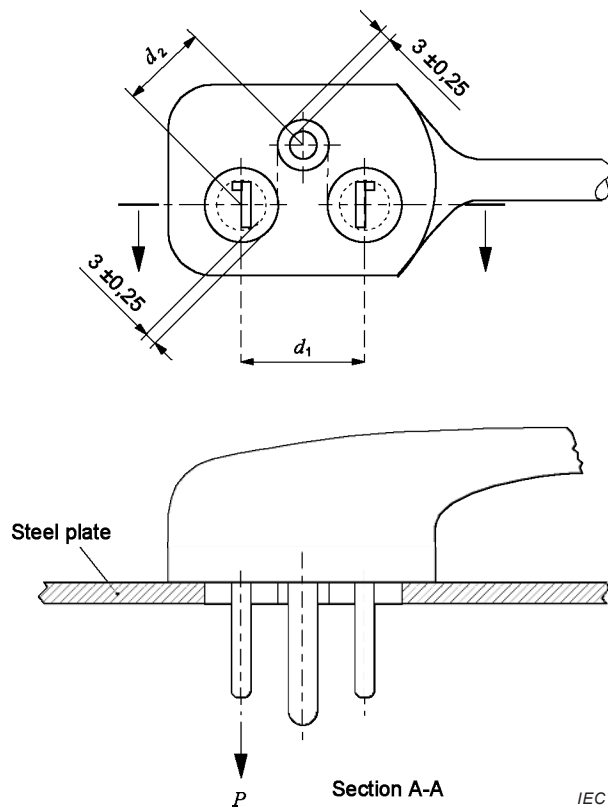

Figure 20 – Apparatus for impact test at low temperature of 24.5

Dimensions in millimetres



Key

P pull

Figure 21 – Example of test arrangement to verify the fixation of pins in the body of the plug

Dimensions in millimetres

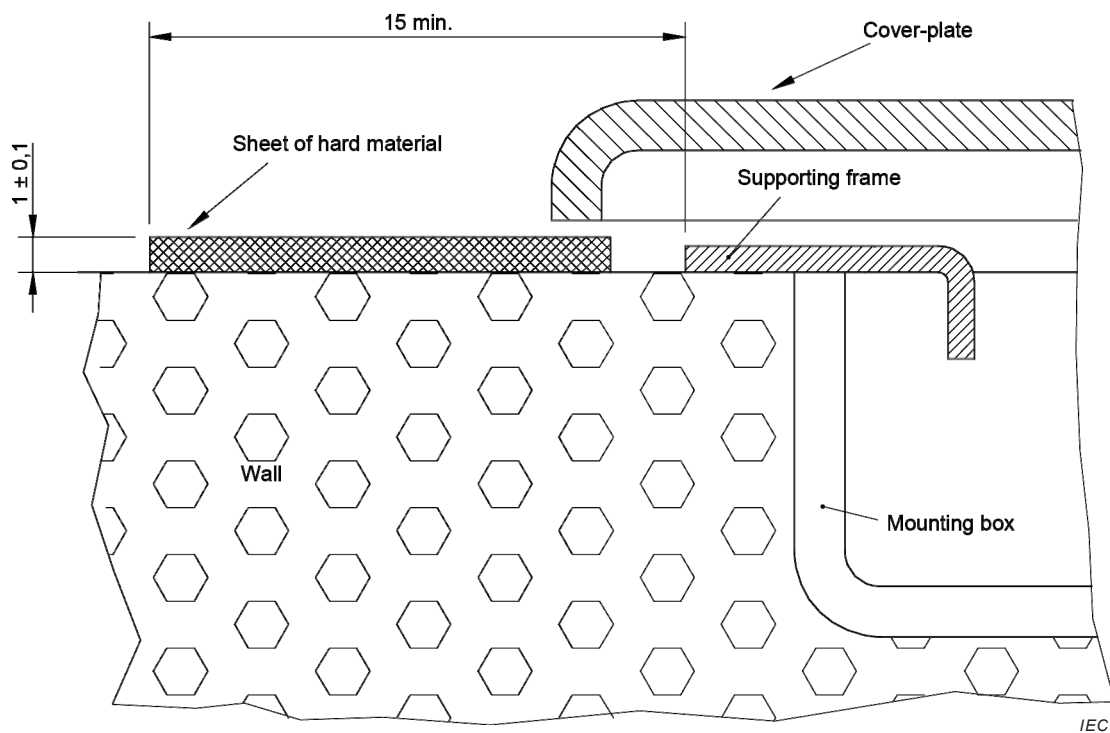

Figure 22 – Arrangement for test on covers or cover-plates

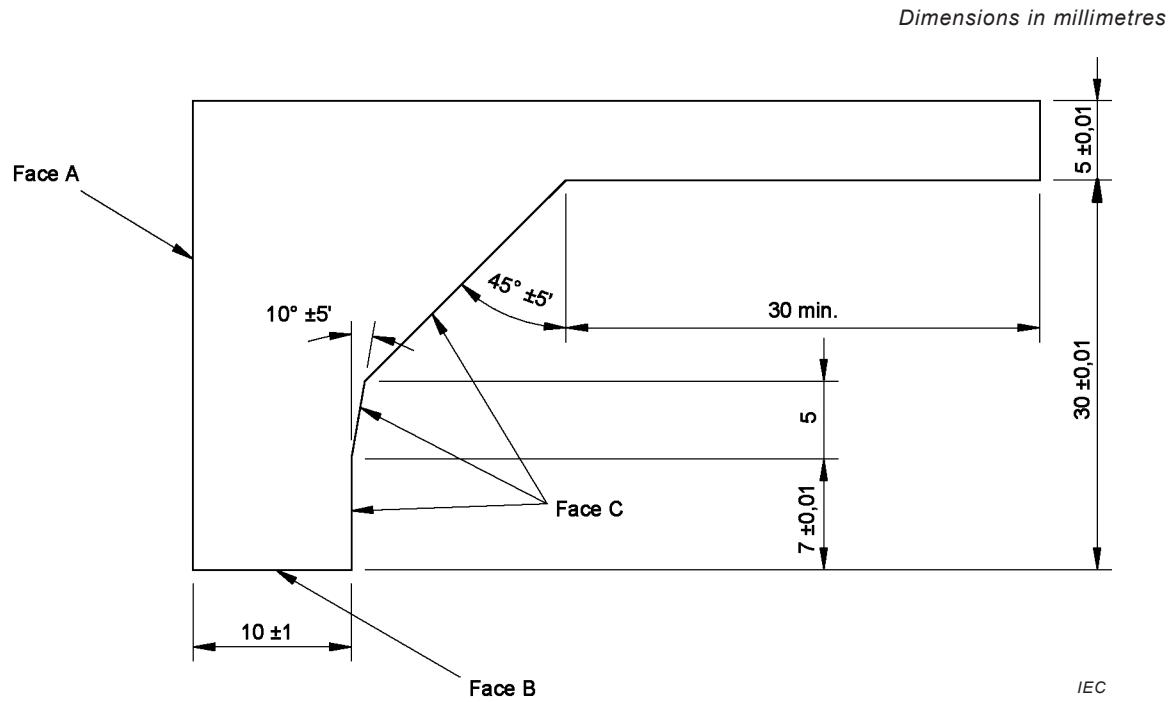
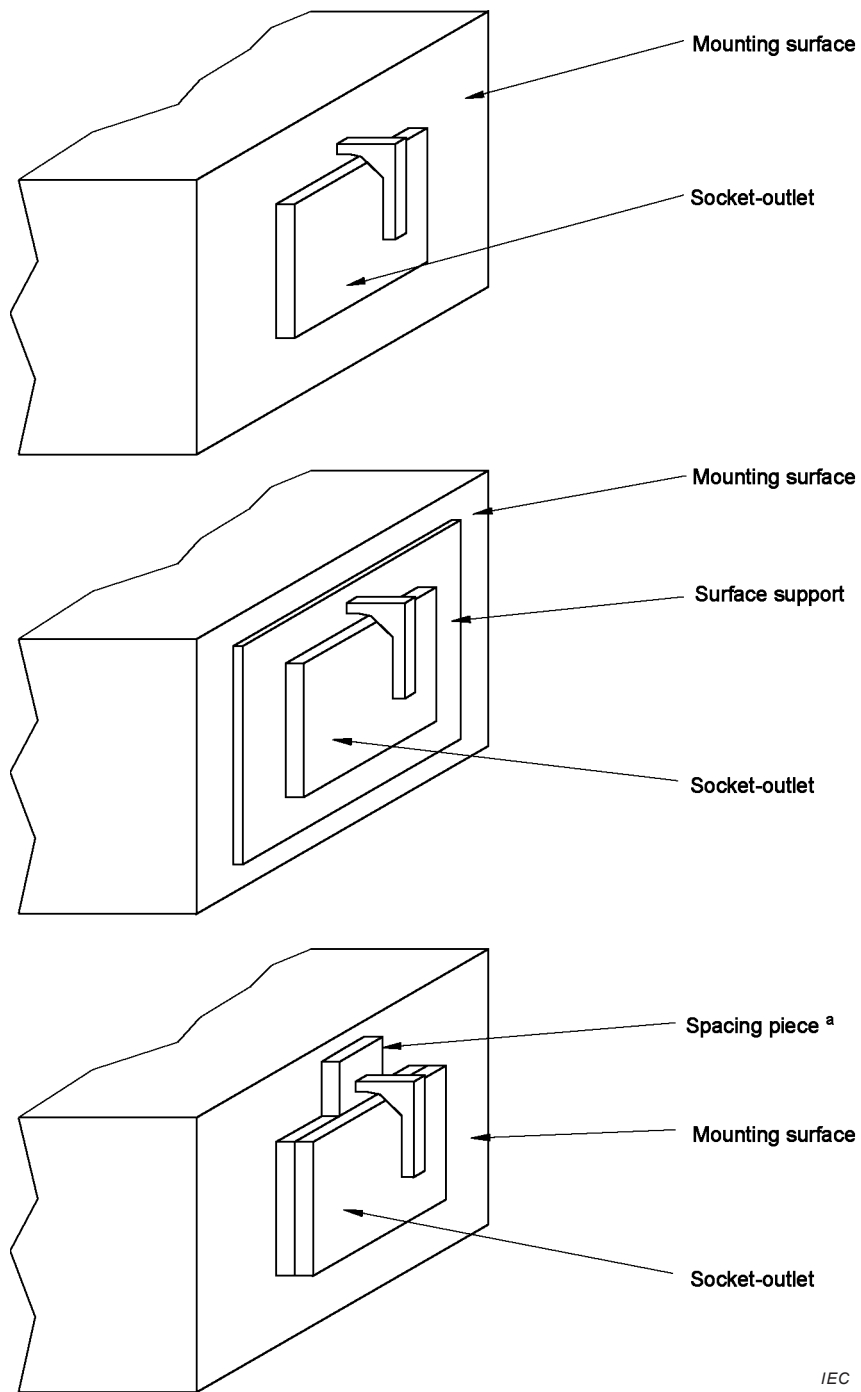

Figure 23 – Gauge (thickness about 2 mm) for the verification of the outline of covers or cover-plates

Dimensions in millimetres



^a The spacing piece has the same thickness as the supporting part.

Figure 24 – Examples of application of the gauge of Figure 23 on covers fixed without screws on a mounting surface or supporting surface

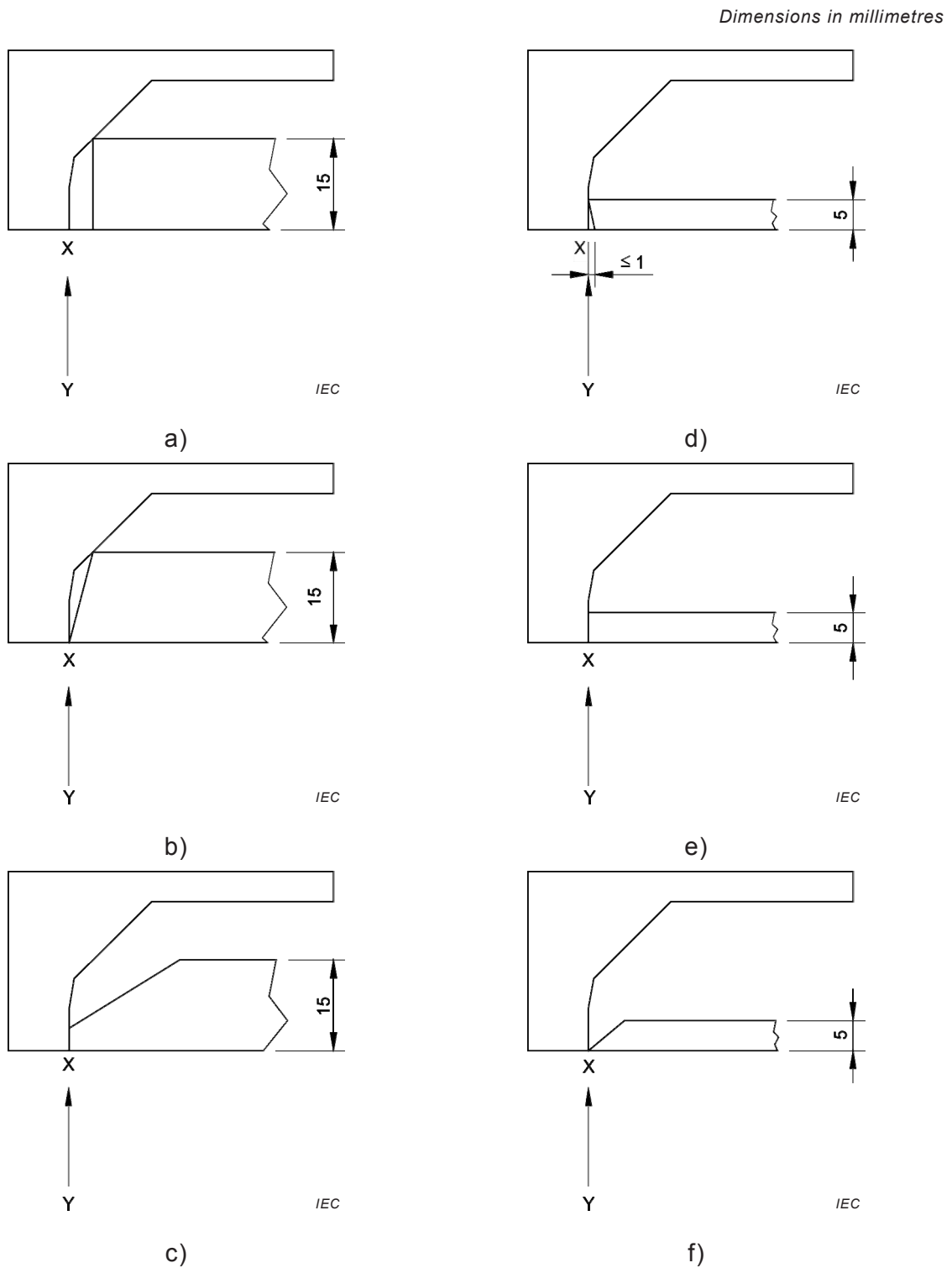

Cases a) and b) do not comply.

Cases c), d), e) and f) comply. (Compliance shall, however, also be checked with the requirements of 24.17, using the gauge shown in Figure 26.)

**Figure 25 – Examples of application of the gauge of Figure 23
in accordance with the requirements of 24.16**

Dimensions in millimetres

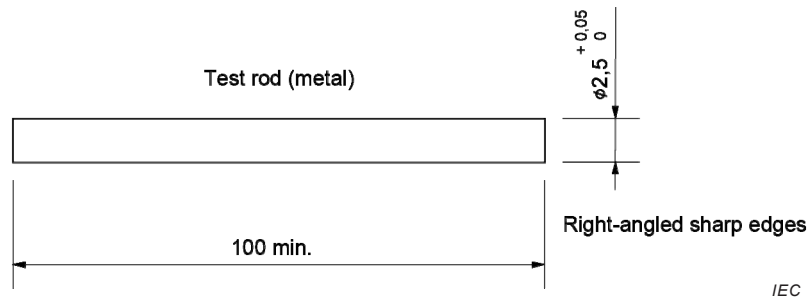

Figure 26 – Gauge for verification of grooves, holes and reverse tapers

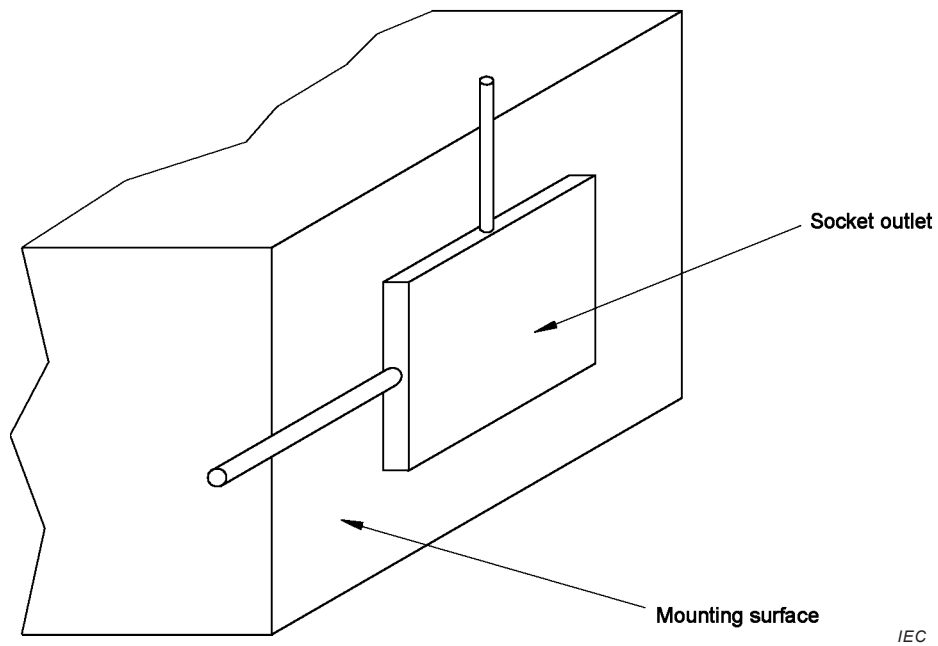

Figure 27 – Sketch showing the direction of application of the gauge of Figure 26

Dimensions in millimetres

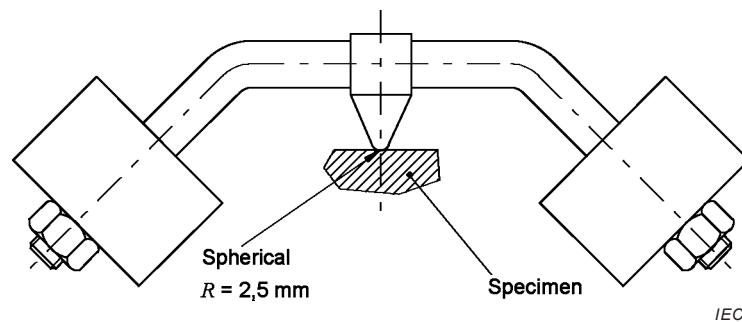
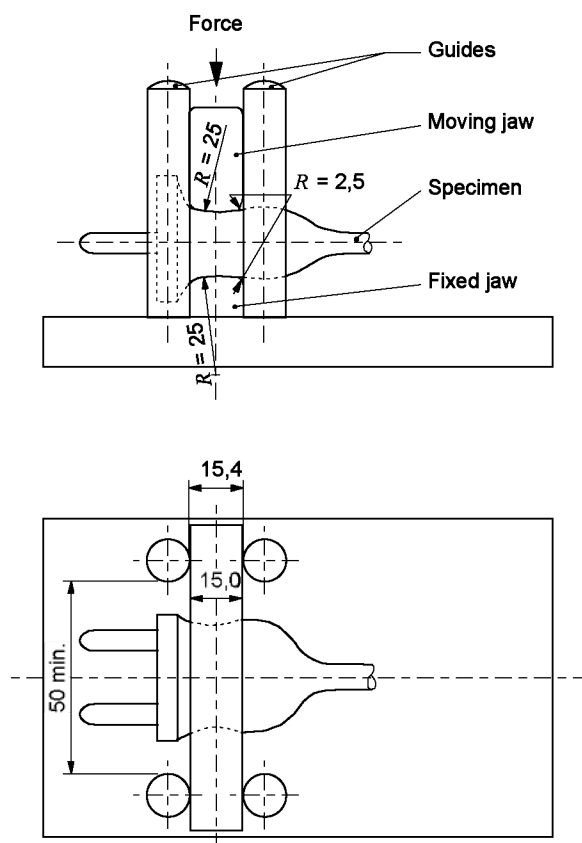

Figure 28 – Ball pressure test apparatus

Dimensions in millimetres



IEC

Figure 29 – Apparatus for compression test for the verification of resistance to heat of 25.5

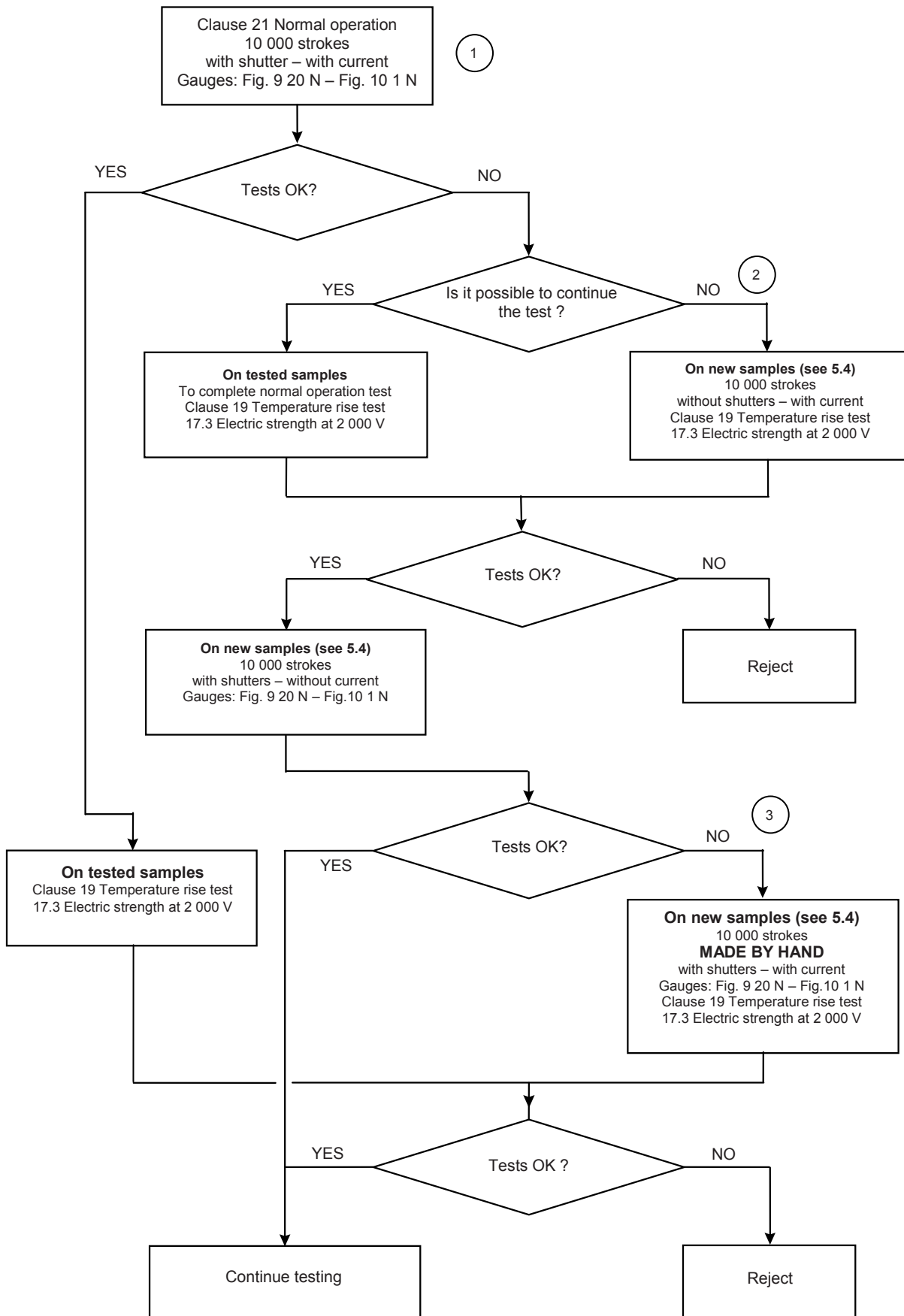
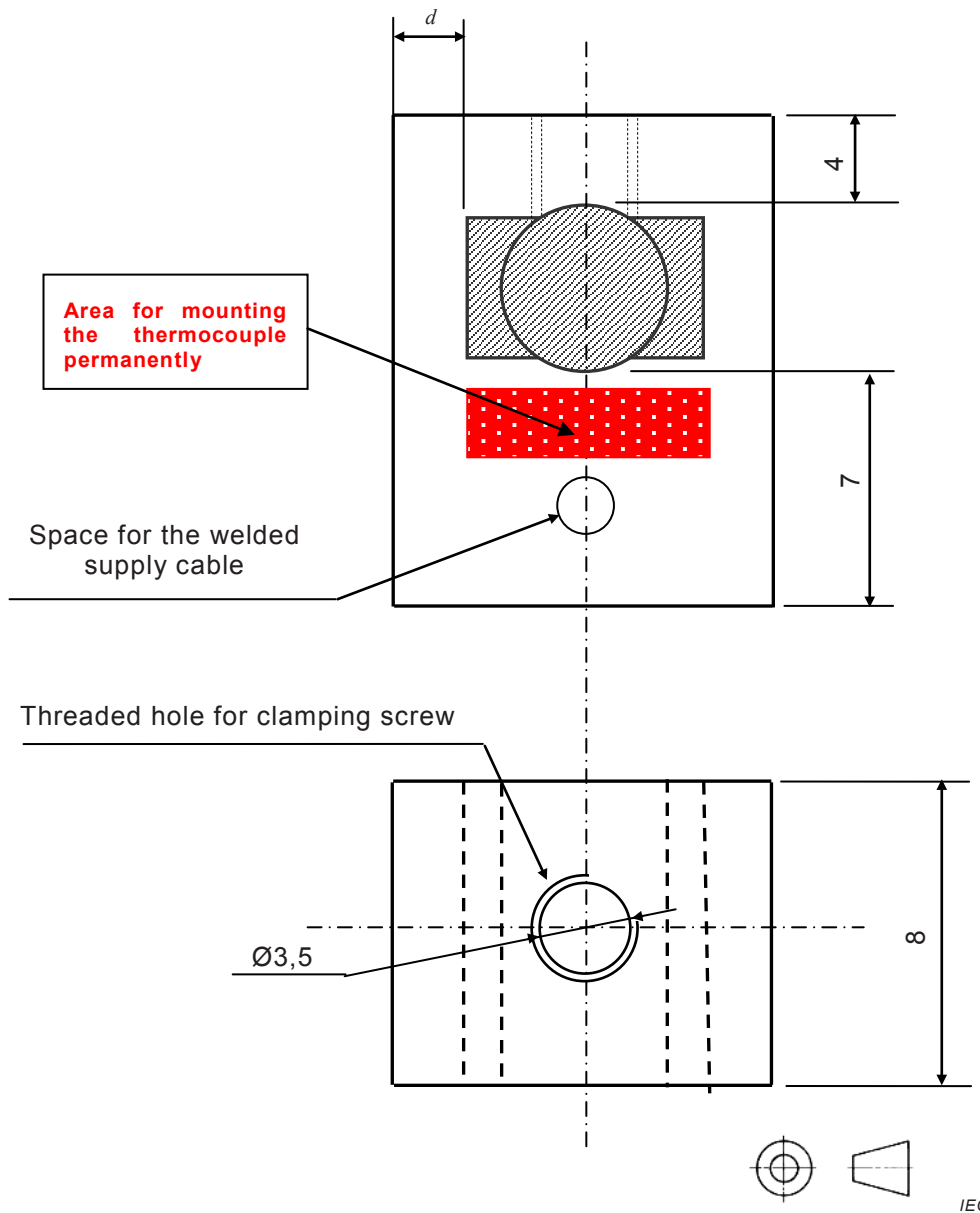

Figure 30 – Test procedures for normal operation (see Clause 21)

Dimensions in millimetres



Material: brass with at least 52 % of copper

Tolerance: $\pm 0,2$ mm unless otherwise stated

NOTE 1 The dimension(s) for the shaded area is(are) the maximum plug pin dimension(s) + 0,8 mm.

NOTE 2 $1,5 \leq d \leq 3$

NOTE 3 The thermocouple is placed within the shaded area but not directly under the clamping screw.

Figure 31 – Clamping unit for the temperature rise test of Clause 19

Simulation – $C_S = 3,3 \text{ mF}$, $C_L = 6,8 \text{ } \mu\text{F}$, $L = 500 \text{ mm}$

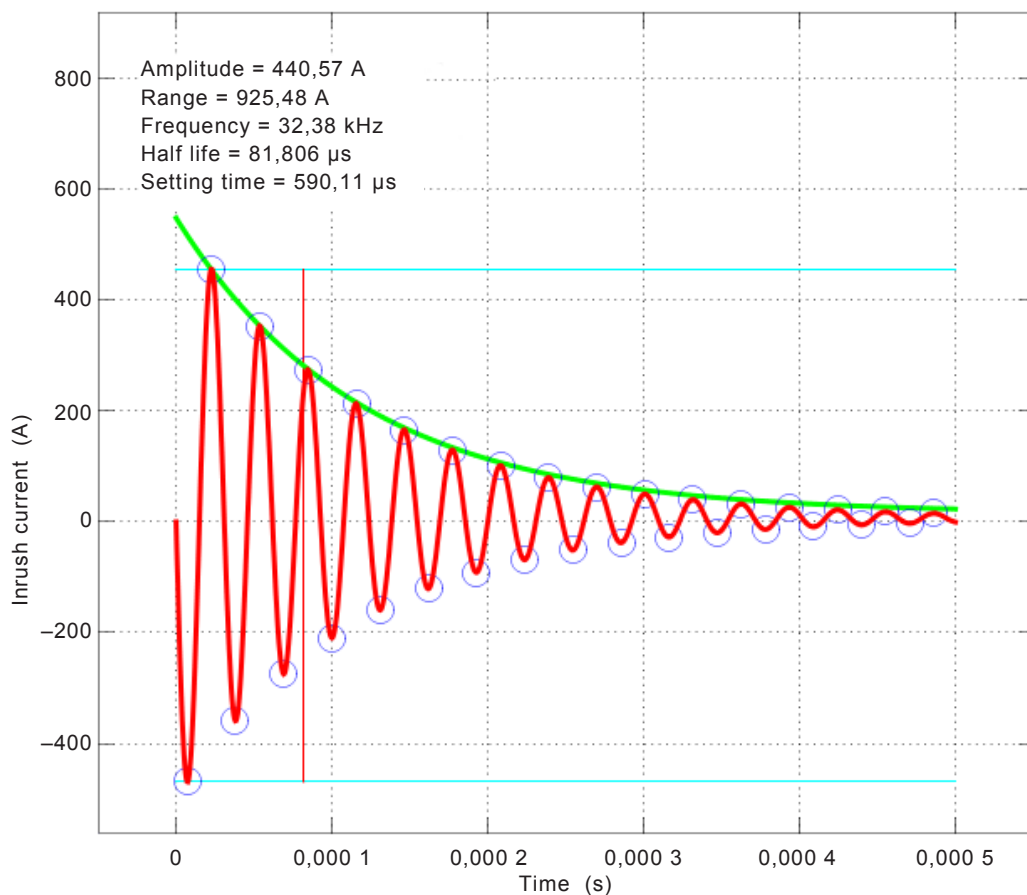

IEC

NOTE An inrush current with a profile as given in Figure 32 can be obtained by using a circuit as given in Figure 33.

Figure 32 – The profile of the inrush current for the test of Clause 20

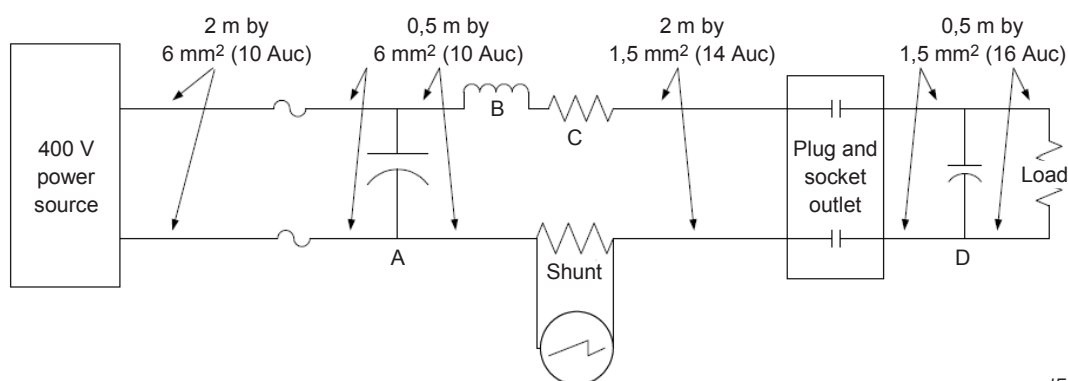

IEC

- A Source – estimated capacitor value 3 300 μF
- B Inductor – estimated value 3,5 μH
- C Variable resistor – estimated value 0,5 Ω
- D Load X-capacitor – estimated value 6,8 μF

Value of components need to be chosen in such a way to obtain the test load and inrush current as required for the test sequence

Figure 33 – Annex to Figure 32 with additional information on a possible circuit to produce the inrush current as given in Figure 32

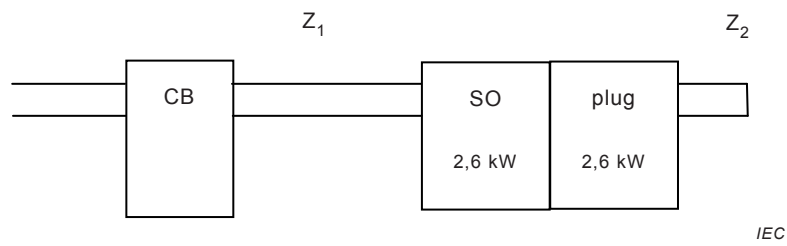

Key

- CB circuit breaker
- SO socket-outlet
- Z_1, Z_2 short circuits

Figure 34 – Circuit diagram for testing socket-outlets and plugs according to 18.2

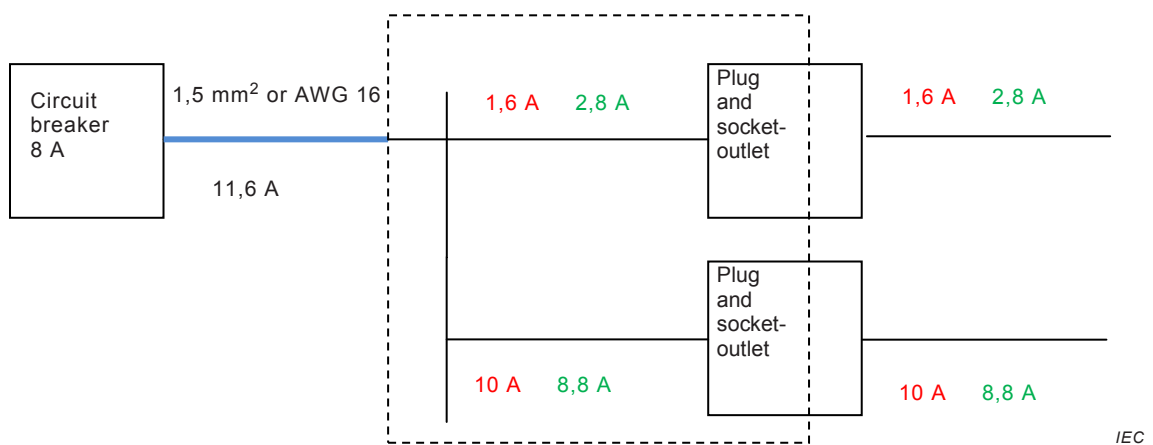

NOTE If there are more than 2 socket-outlets these 2 are the most remote from the supply.

Figure 35 – Possible test setup for the temperature rise test for Clauses 19 and 21

Annex A (normative)

Safety-related routine tests for factory-wired accessories (protection against electric shock and correct polarity)

A.1 General remarks

All factory-wired plugs and socket-outlets shall be subjected to all the following tests.

The test equipment or manufacturing systems shall be such that failed products are either made unfit for use or separated from satisfactory products in such a way that they cannot be released for sale.

"Unfit for use" means that the accessory is treated in such a way that it cannot fulfil the intended function. It is, however, accepted that repairable products (by a reliable system) may be repaired and re-tested.

It shall be possible by process or manufacturing system to identify that accessories released for sale have been subjected to all the appropriate tests.

The manufacturers shall maintain records of the tests carried out which show

- the type of product;
- the date of test;
- the place of manufacture (if manufactured in more than one place);
- the quantity tested;
- the number of failures and actions taken, i.e. destroyed/repaired.

The test equipment shall be checked before and after each period of use and for periods of continuous use, at least once every 24 h. During these checks the equipment shall show that it indicates faults when known faulty products are inserted or simulated faults are applied.

Products manufactured prior to a check shall only be released for sale if the check is found satisfactory.

Test equipment shall be verified (calibrated) at least once a year. Records shall be kept of all checks and any adjustments found necessary.

A.2 Polarized systems, "+" and "-" – correct connection

For polarized systems the test shall be made using SELV applied for a period of not less than 2 s:

- *for plugs and socket-outlets, between the remote end of the "+" and "-" conductors of the flexible cable independently, and the corresponding "+" and "-" pin or contact of the accessory;*
- *for cord extension sets, between the "+" and "-" pin at one end of the flexible cable and the corresponding "+" and "-" contact at the other end of the flexible cable.*

Polarity shall be correct.

The period of 2 s may be reduced to not less than 1 s on test equipment with automatic timing.

A.3 Earth continuity

The test shall be made using SELV applied for a period of not less than 2 s:

- *for plugs and socket-outlets, between the remote end of the earth conductor of the flexible cable, and the earth pin or contact of the accessory, as appropriate;*
- *for cord extension sets, between the corresponding earth pin or earth contact of the accessory at each end of the flexible cable.*

Continuity shall be present.

The period of 2 s may be reduced to not less than 1 s on test equipment with automatic timing.



A.4 Short-circuit/wrong connection and reduction of creepage distance and clearances between “+” and “-” to earth ()

The test shall be made by

- *applying at the supply end, for example to a plug, for a period of not less than 2 s, 2 000 V ± 10 %;*

The period of 2 s may be reduced to not less than 1 s on test equipment with automatic timing.

or

- *by applying an impulse voltage test using a 1,2/50 μs waveform of 4 kV peak value and three impulses for each pole, with intervals of not less than 1 s,*
 - *between “+” and , and*
 - *between “-” and .*

“+” and “-” may be connected together for this test.

No flashover shall occur.

Annex B (normative)

Survey of specimens needed for tests

The number of specimens needed for the tests according to 5.5 are as given in Table B.1.

Table B.1 – Number of specimens needed for the tests according to 5.5

Clauses and subclauses		Number of specimens	
		Fixed socket-outlets	Plugs
6	Ratings	A	A
7	Classification	A	A
8	Marking	A	A
9	Checking of dimensions	ABC	ABC
10	Protection against electric shock	ABC	ABC
11	Provision for earthing	ABC	ABC
12	Terminals	ABC ^a	ABC
13	Construction of fixed socket-outlets	ABC ^b	–
14	Construction of plugs	–	ABC ^b
15	Interlocked socket-outlets		
16	Resistance to ageing, to harmful ingress of water and to humidity	ABC	ABC
17	Insulation resistance and electric strength	ABC	ABC
18	Operation of earthing contacts	ABC	ABC
19	Temperature rise	ABC	ABC
20	Breaking capacity	ABC	ABC
21	Normal operation	ABC	ABC
22	Force necessary to withdraw the plug	ABC	–
23	Flexible cables and their connection	–	ABC ^c
24	Mechanical strength	ABC ^{d e}	ABC ^f
25	Resistance to heat	ABC	ABC
26	Screws, current-carrying parts and connections	ABC	ABC
27	Creepage distances, clearances and distances through sealing compound	ABC	ABC
28	Resistance to abnormal heat and to fire	DEF	DEF
29	Resistance to rusting	ABC	ABC
	TOTAL	6	6

^a One extra set of specimens is used for the test of 12.3.10, five extra screwless terminals are used for the test of 12.3.11 and one extra set of specimens is used for the test of 12.3.12.

^b One extra set of membranes is needed for the tests of 13.19.

^c One extra set of specimens is needed for 23.2 and 23.4 about non-rewirable accessories for each type of cable and cross-sectional area.

^d One extra set of specimens is needed for 24.8 about shuttered socket-outlets.

^e One extra set of specimens is needed for 24.13.1 and 24.13.2.

^f One extra set of specimens is needed for 24.9 about plugs.

Annex C (informative)

Alternative gripping tests

C.1 Gripping test C1

Prior to testing, the reference plug shown in Figure C.1 shall be cleaned with a metal cleaner.

The reference plug, the plug to be tested, and the hands of each person conducting the test shall be washed with soap and water, rinsed, and then dried.

The test apparatus consists of a measuring device equipped with a means to securely attach both the reference plug and the plug to be tested, in a manner that reduces the likelihood of rotational movement during the pulls. An engagement face simulating the use of a plug in a socket-outlet of the same system, having an opening for the plug pins shall be secured to the movable member.

NOTE Other methods for measuring force can be used.

The mounting arrangements for the plug being tested shall be such that the face of the plug is flush with the faceplate.

Typical apparatus is shown in Figure C.2.

The plug to be tested with the flexible cable cut off close to the plug shall be securely attached to the test apparatus.

The person performing the test shall grip the plug to be tested with either hand in a manner intended to apply the maximum pull force.

A steady straight pull shall be applied until the plug pulls free from the person's hand.

The person applying the force shall not view the force indicator during the pull.

The maximum pull force applied during the pull shall be recorded.

Immediately following the pull test, the reference plug shall be attached to the test apparatus and a comparison pull made using the same hand.

The maximum pull force shall be recorded.

The ratio of the force for the plug under test to that for the reference plug shall be calculated and recorded.

The comparison pull procedure described above shall be repeated on the same plug an additional two times by the same person.

The ratio for each pair of pulls (test plug/reference plug) shall be calculated and recorded.

One person shall test three plugs (total nine comparison pulls) as described above with the ratio for each pair of pulls being calculated and recorded for all three plugs. If the ratio of the pull force (plug under test/reference plug) for each pair of pulls resulting from the tests carried out by this person is 0,8 or greater, the test shall be stopped and the results considered acceptable.

If the ratio is lower than 0,8, two additional people shall test three plugs each (for a total of nine comparison pulls per person), as described above.

The ratio for each pair of pulls (plug under test/reference plug) shall be calculated and recorded.

The results are considered acceptable if all of the following conditions are met:

- a) the ratio for each pair of pulls (test/reference plug) is 0,55 or greater for at least two pulls (of the three pulls performed) on each plug;
- b) at least two (of the three) plugs tested by each person comply with item a); and
- c) at least two persons' test results comply with item b).

If only one person obtains results that comply with item b) then, at the manufacturer's request, two persons not previously involved in the testing may test three plugs each as previously described.

The results are considered acceptable if both of the additional persons' test results comply with items a) and b).

No result should be lower than the maximum withdrawal force for the relevant socket-outlet as specified in Table 16.

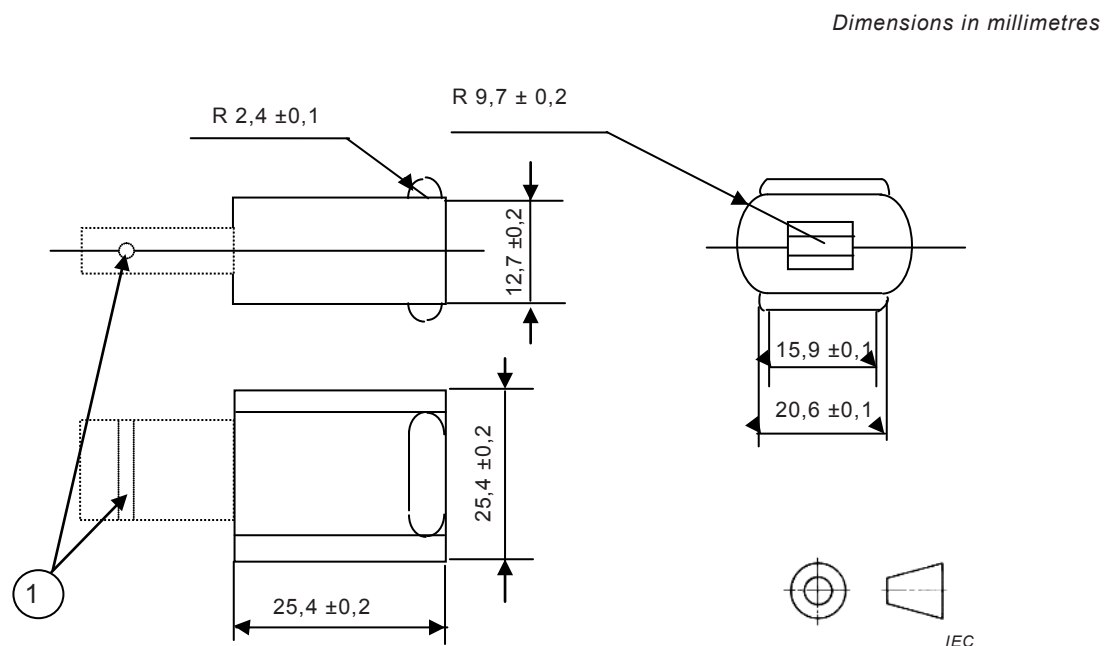

Key

1 Hole for retaining pins.

Material: for example heat-treated steel.

Surface roughness of the gripping surface: between $0,6 \mu\text{m}$ and $0,8 \mu\text{m}$.

The dimensions are to suit the test specimen and those of Figure C.2.

Figure C.1 – Reference plug for gripping test

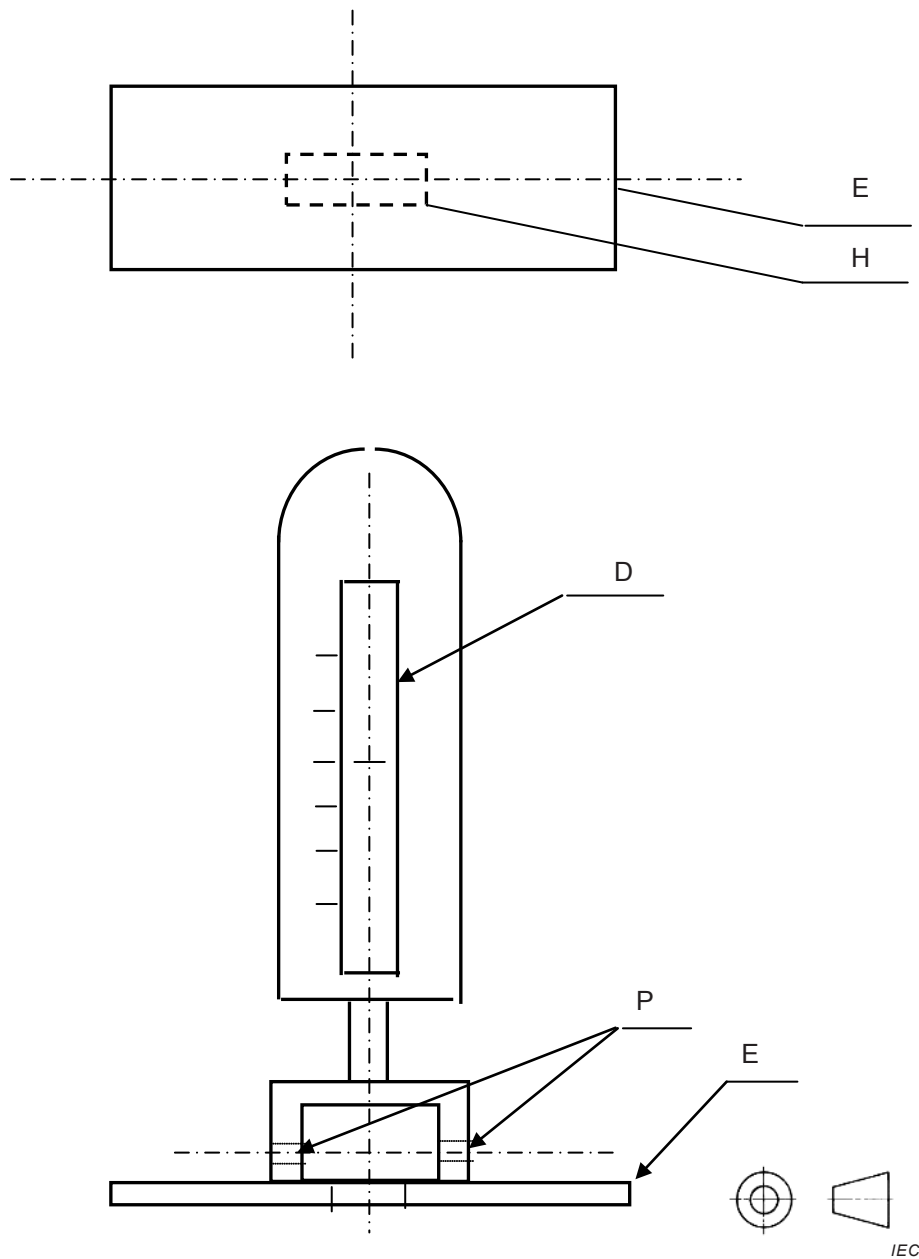

Key

- E Simulated engagement face
- H Hole for introduction of fixing means
- P Holes for pins for retention of fixing means
- D Measuring device

NOTE The figure is for guidance only and is not intended to govern the design of the test apparatus.

Figure C.2 – Example of the test apparatus for plug gripping test

C.2 Gripping test C2

This test consists of a verification of one of the following characteristics of the plug under test:

- *the plug has a usable length for gripping of at least 55 mm in the axial direction; or*
- *the plug has such indent(s) that a ball with a diameter of $(12 \pm 0,1)$ mm can penetrate radially into the body at least 2 mm from two opposite directions or at least 4 mm from one direction; or*

– *the plug has special means for withdrawal (e.g. hooks, rings).*

The results are considered acceptable if at least one of the above conditions is fulfilled.

Annex D (normative)

Standard sheets and gauges

D.1 Standard sheets

See Figures D.1 to D.3.

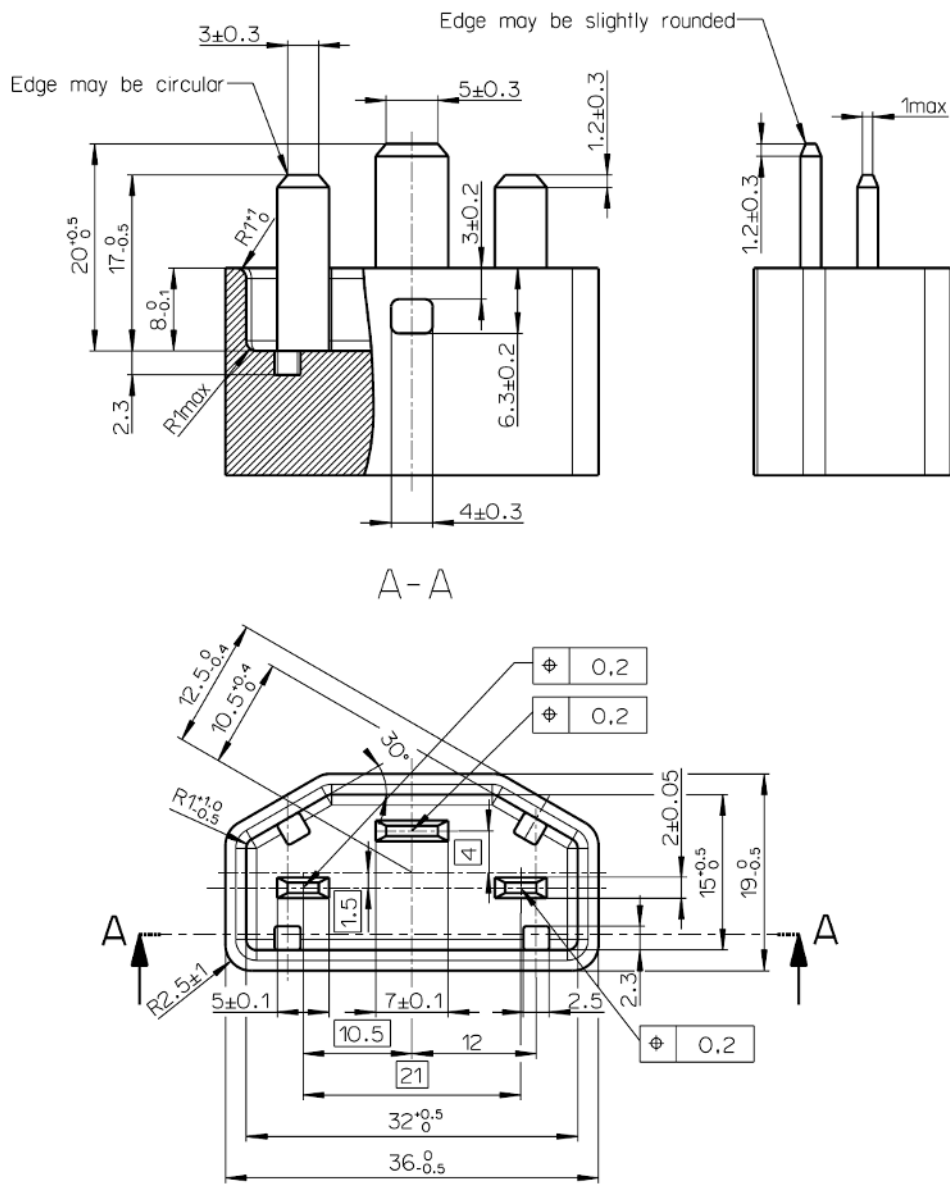

IEC

Figure D.2 – Standard sheet 2: 2,6 kW / 294 V to 400 V d.c. plug for class I equipment

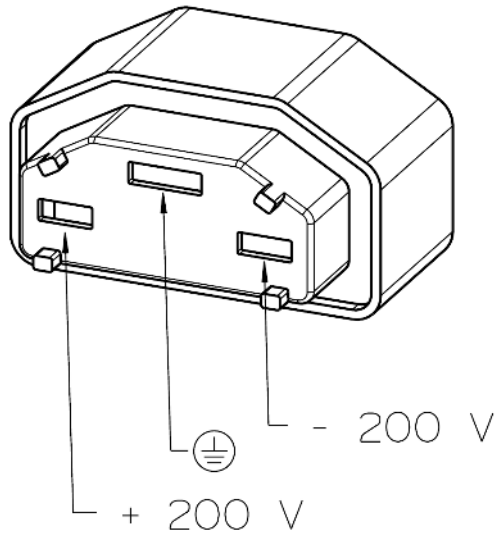
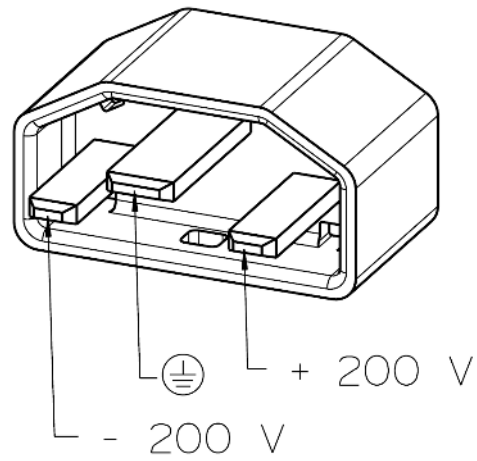

IEC

Figure D.3 – Standard sheet 3: positioning of the “+” and “-” pins/socket-contacts

D.2 Gauges for checking the dimensions of the entry holes

See Figures D.4 to D.8.

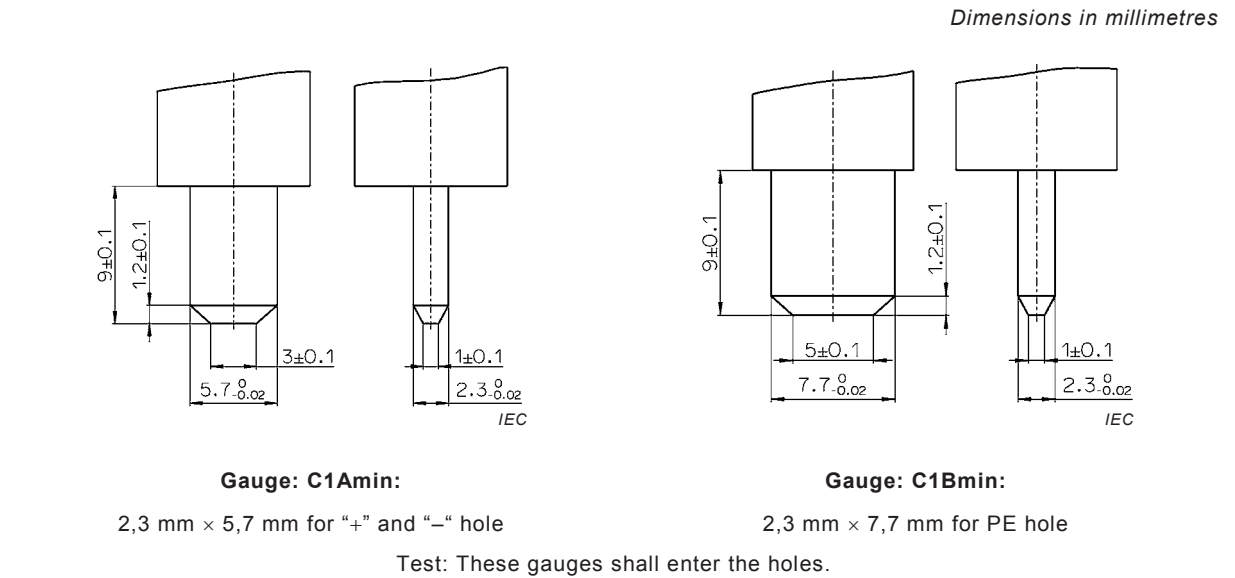

Figure D.4 – Minimum gauges for checking the dimensions of the entry holes: C1

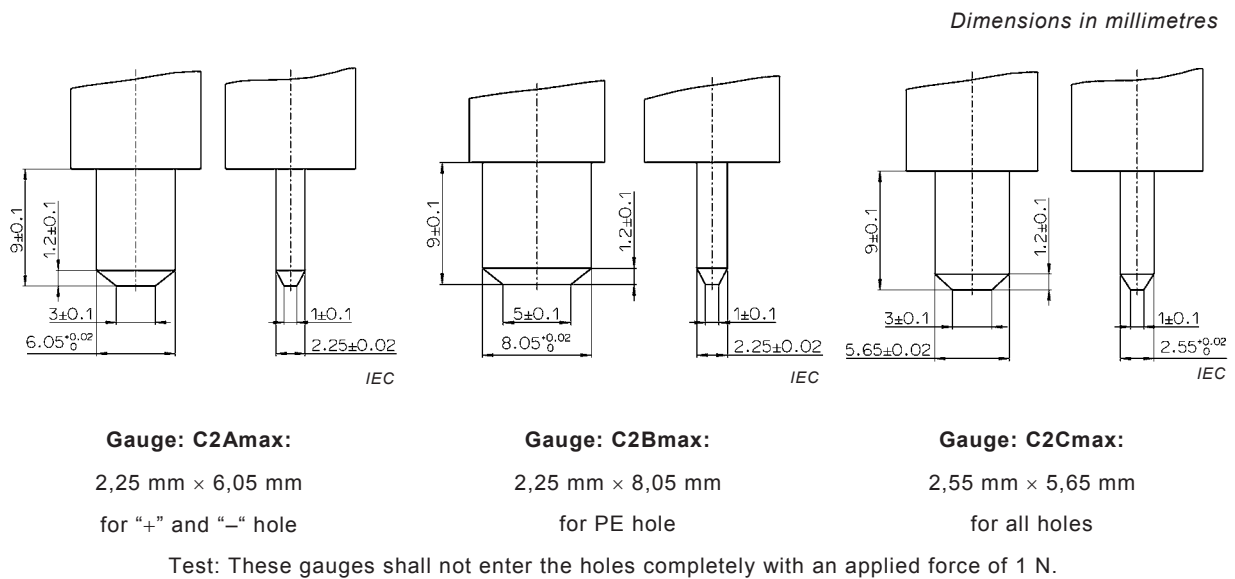
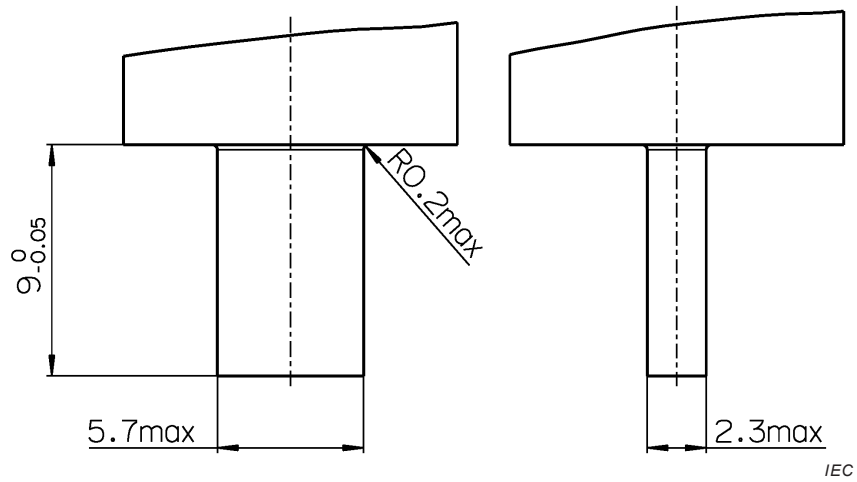

Figure D.5 – Maximum gauges for checking the dimensions of the entry holes: C2

Dimensions in millimetres



Test: The gauge is entered into the holes of the socket-outlet and moved around in the hole while keeping it perpendicular to the engagement face. The gauge shall not touch the “+” and the “-” contacts.

Figure D.6 – Gauge for checking the first point of contact: C3

Dimensions in millimetres

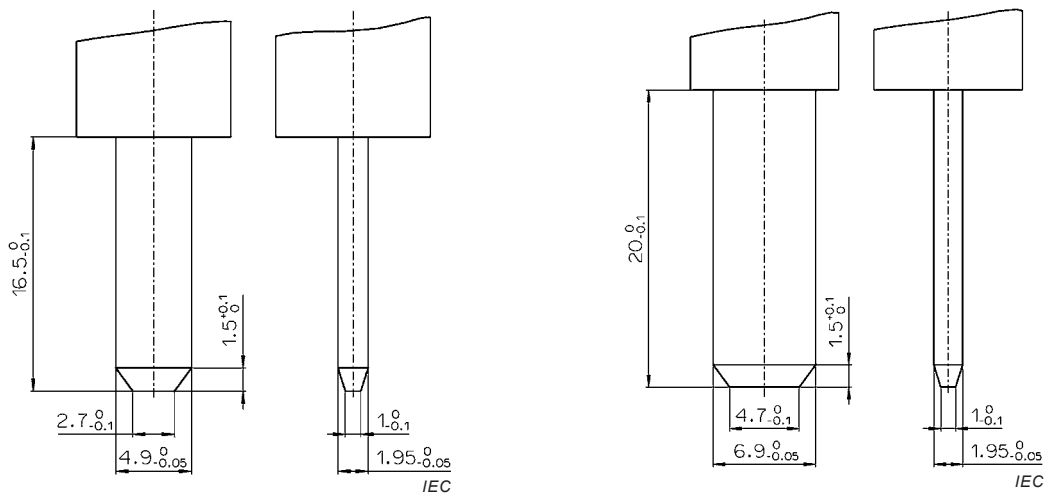

Gauge: C4Amin:

4,90 mm × 1,95 mm for “+” and “-” pin

Gauge: C4Bmin:

6,90 mm × 1,95 mm for PE pin

Figure D.7 – Gauges for checking the minimum withdrawal force (see 22.3)

Bibliography

IEC 60068-2-30, *Environmental testing – Part 2-30: Tests – Test Db: Damp heat, cyclic (12 h + 12 h cycle)*

IEC 60364 (all parts), *Low-voltage electrical installations*

IEC 60417, *Graphical symbols for use on equipment* (available from: <http://www.graphical-symbols.info/equipment>)

ISO/IEC Guide 51, *Safety aspects – Guidelines for their inclusion in standards*

British Standards Institution (BSI)

BSI is the national body responsible for preparing British Standards and other standards-related publications, information and services.

BSI is incorporated by Royal Charter. British Standards and other standardization products are published by BSI Standards Limited.

About us

We bring together business, industry, government, consumers, innovators and others to shape their combined experience and expertise into standards-based solutions.

The knowledge embodied in our standards has been carefully assembled in a dependable format and refined through our open consultation process. Organizations of all sizes and across all sectors choose standards to help them achieve their goals.

Information on standards

We can provide you with the knowledge that your organization needs to succeed. Find out more about British Standards by visiting our website at bsigroup.com/standards or contacting our Customer Services team or Knowledge Centre.

Buying standards

You can buy and download PDF versions of BSI publications, including British and adopted European and international standards, through our website at bsigroup.com/shop, where hard copies can also be purchased.

If you need international and foreign standards from other Standards Development Organizations, hard copies can be ordered from our Customer Services team.

Subscriptions

Our range of subscription services are designed to make using standards easier for you. For further information on our subscription products go to bsigroup.com/subscriptions.

With **British Standards Online (BSOL)** you'll have instant access to over 55,000 British and adopted European and international standards from your desktop. It's available 24/7 and is refreshed daily so you'll always be up to date.

You can keep in touch with standards developments and receive substantial discounts on the purchase price of standards, both in single copy and subscription format, by becoming a **BSI Subscribing Member**.

PLUS is an updating service exclusive to BSI Subscribing Members. You will automatically receive the latest hard copy of your standards when they're revised or replaced.

To find out more about becoming a BSI Subscribing Member and the benefits of membership, please visit bsigroup.com/shop.

With a **Multi-User Network Licence (MUNL)** you are able to host standards publications on your intranet. Licences can cover as few or as many users as you wish. With updates supplied as soon as they're available, you can be sure your documentation is current. For further information, email bsmusales@bsigroup.com.

BSI Group Headquarters

389 Chiswick High Road London W4 4AL UK

Revisions

Our British Standards and other publications are updated by amendment or revision.

We continually improve the quality of our products and services to benefit your business. If you find an inaccuracy or ambiguity within a British Standard or other BSI publication please inform the Knowledge Centre.

Copyright

All the data, software and documentation set out in all British Standards and other BSI publications are the property of and copyrighted by BSI, or some person or entity that owns copyright in the information used (such as the international standardization bodies) and has formally licensed such information to BSI for commercial publication and use. Except as permitted under the Copyright, Designs and Patents Act 1988 no extract may be reproduced, stored in a retrieval system or transmitted in any form or by any means – electronic, photocopying, recording or otherwise – without prior written permission from BSI. Details and advice can be obtained from the Copyright & Licensing Department.

Useful Contacts:

Customer Services

Tel: +44 845 086 9001

Email (orders): orders@bsigroup.com

Email (enquiries): cservices@bsigroup.com

Subscriptions

Tel: +44 845 086 9001

Email: subscriptions@bsigroup.com

Knowledge Centre

Tel: +44 20 8996 7004

Email: knowledgecentre@bsigroup.com

Copyright & Licensing

Tel: +44 20 8996 7070

Email: copyright@bsigroup.com



...making excellence a habit.™