



BSI Standards Publication

Nanomanufacturing — Key control characteristics

Part 4-2: Nano-enabled electrical energy storage — Physical characterization of cathode nanomaterials, density measurement

National foreword

This Published Document is the UK implementation of IEC/TS 62607-4-2:2016.

The UK participation in its preparation was entrusted to Technical Committee NTI/1, Nanotechnologies.

A list of organizations represented on this committee can be obtained on request to its secretary.

This publication does not purport to include all the necessary provisions of a contract. Users are responsible for its correct application.

© The British Standards Institution 2016.

Published by BSI Standards Limited 2016

ISBN 978 0 580 89475 6

ICS 07.120

Compliance with a British Standard cannot confer immunity from legal obligations.

This Published Document was published under the authority of the Standards Policy and Strategy Committee on 30 November 2016.

Amendments/corrigenda issued since publication

Date	Text affected
-------------	----------------------



TECHNICAL SPECIFICATION



**Nanomanufacturing – Key control characteristics –
Part 4-2: Nano-enabled electrical energy storage – Physical characterization
of cathode nanomaterials, density measurement**

INTERNATIONAL
ELECTROTECHNICAL
COMMISSION

ICS 07.120

ISBN 978-2-8322-3697-0

Warning! Make sure that you obtained this publication from an authorized distributor.

CONTENTS

FOREWORD	4
INTRODUCTION	6
1 Scope	7
2 Normative references	7
3 Terms, definitions, and abbreviated terms	7
3.1 Terms and definitions	7
3.2 Abbreviated terms	8
4 Sample preparation methods	8
4.1 Sieving	8
4.2 Drying	8
5 Test methods	8
5.1 Compacted density	8
5.1.1 General	8
5.1.2 Apparatus	9
5.1.3 Measurement steps	9
5.1.4 Data analysis / interpretation of results	9
5.1.5 Precision of the method	10
5.2 Rolling density	10
5.2.1 General	10
5.2.2 Apparatus	11
5.2.3 Measurement steps	11
5.2.4 Data analysis / interpretation of results	11
5.2.5 Repeatability of the method	12
6 Uncertainty	12
Annex A (informative) Case study	13
A.1 Sample preparation	13
A.1.1 Schematic figures of die for measuring compacted density and rolling density	13
A.1.2 Compacted density measurement results for LFP nanomaterial	15
A.2 Rolling density sample preparation case study	17
A.2.1 Procedures of rolling density sample preparation	17
A.2.2 Rolling density measurement results for LFP nanomaterial	18
Bibliography	20
Figure 1 – Appearance of die for compacted density measurement	10
Figure 2 – Appearance of die with compressor	10
Figure A.1 – Three-dimensional schematic of die for compacted density measurement	13
Figure A.2 – Engineering schematic of die for compacted density measurement	14
Figure A.3 – Schematic of rolling machine for rolling density measurement	15
Figure A.4 – Results consistency of sample A in Table A.1	16
Figure A.5 – Results consistency of sample B in Table A.2	17
Figure A.6 – Procedures of rolling density sample preparation	18
Figure A.7 – Results consistency of sample C in Table A.3	19

Table A.1 – Measurement method consistency and measurement results of sample A..... 15
Table A.2 – Measurement method consistency and measurement results of sample B..... 16
Table A.3 – Measurement method consistency and measurement results of sample C..... 19

INTERNATIONAL ELECTROTECHNICAL COMMISSION

**NANOMANUFACTURING –
KEY CONTROL CHARACTERISTICS –****Part 4-2: Nano-enabled electrical energy storage – Physical
characterization of cathode nanomaterials, density measurement**

FOREWORD

- 1) The International Electrotechnical Commission (IEC) is a worldwide organization for standardization comprising all national electrotechnical committees (IEC National Committees). The object of IEC is to promote international co-operation on all questions concerning standardization in the electrical and electronic fields. To this end and in addition to other activities, IEC publishes International Standards, Technical Specifications, Technical Reports, Publicly Available Specifications (PAS) and Guides (hereafter referred to as "IEC Publication(s)"). Their preparation is entrusted to technical committees; any IEC National Committee interested in the subject dealt with may participate in this preparatory work. International, governmental and non-governmental organizations liaising with the IEC also participate in this preparation. IEC collaborates closely with the International Organization for Standardization (ISO) in accordance with conditions determined by agreement between the two organizations.
- 2) The formal decisions or agreements of IEC on technical matters express, as nearly as possible, an international consensus of opinion on the relevant subjects since each technical committee has representation from all interested IEC National Committees.
- 3) IEC Publications have the form of recommendations for international use and are accepted by IEC National Committees in that sense. While all reasonable efforts are made to ensure that the technical content of IEC Publications is accurate, IEC cannot be held responsible for the way in which they are used or for any misinterpretation by any end user.
- 4) In order to promote international uniformity, IEC National Committees undertake to apply IEC Publications transparently to the maximum extent possible in their national and regional publications. Any divergence between any IEC Publication and the corresponding national or regional publication shall be clearly indicated in the latter.
- 5) IEC itself does not provide any attestation of conformity. Independent certification bodies provide conformity assessment services and, in some areas, access to IEC marks of conformity. IEC is not responsible for any services carried out by independent certification bodies.
- 6) All users should ensure that they have the latest edition of this publication.
- 7) No liability shall attach to IEC or its directors, employees, servants or agents including individual experts and members of its technical committees and IEC National Committees for any personal injury, property damage or other damage of any nature whatsoever, whether direct or indirect, or for costs (including legal fees) and expenses arising out of the publication, use of, or reliance upon, this IEC Publication or any other IEC Publications.
- 8) Attention is drawn to the Normative references cited in this publication. Use of the referenced publications is indispensable for the correct application of this publication.
- 9) Attention is drawn to the possibility that some of the elements of this IEC Publication may be the subject of patent rights. IEC shall not be held responsible for identifying any or all such patent rights.

The main task of IEC technical committees is to prepare International Standards. In exceptional circumstances, a technical committee may propose the publication of a Technical Specification when

- the required support cannot be obtained for the publication of an International Standard, despite repeated efforts, or
- the subject is still under technical development or where, for any other reason, there is the future but no immediate possibility of an agreement on an International Standard.

Technical Specifications are subject to review within three years of publication to decide whether they can be transformed into International Standards.

IEC TS 62607-4-2, which is a Technical Specification, has been prepared by IEC technical committee 113: Nanotechnology for electrotechnical products and systems.

The text of this Technical Specification is based on the following documents:

Enquiry draft	Report on voting
113/289/DTS	113/328/RVC

Full information on the voting for the approval of this Technical Specification can be found in the report on voting indicated in the above table.

This publication has been drafted in accordance with the ISO/IEC Directives, Part 2.

A list of all parts in the IEC 62607 series, published under the general title *Nanomanufacturing – Key control characteristics*, can be found on the IEC website.

The committee has decided that the contents of this document will remain unchanged until the stability date indicated on the IEC website under "<http://webstore.iec.ch>" in the data related to the specific publication. At this date, the publication will be

- transformed into an International Standard,
- reconfirmed,
- withdrawn,
- replaced by a revised edition, or
- amended.

A bilingual version of this publication may be issued at a later date.

IMPORTANT – The 'colour inside' logo on the cover page of this publication indicates that it contains colours which are considered to be useful for the correct understanding of its contents. Users should therefore print this document using a colour printer.

INTRODUCTION

Compared with normal bulk materials, nanomaterials often exhibit many unique properties, such as mechanical, thermal, magnetic, optical and electrochemical properties. Decreasing particle size of the cathode materials, e.g. lithium iron phosphate (LFP), down to nanoscale greatly enhances their electrochemical performance. For example, smaller particle size will shorten the diffusion length of lithium ion during lithium intercalation/de-intercalation process. Higher surface area will increase the electrode/electrolyte contact area, and subsequently improve the high current charge/discharge rates. Furthermore, the particle surfaces may introduce a sub-gap, which can smooth the electrode discharge curve, then help to prolong the cycling life of the electrode.

Density is one of the key control characteristics for cathode nanomaterials and affects the performance of electronic energy storage devices significantly. At an appropriate density, the electrochemical performance, such as low-temperature and high-temperature charge/discharge, and the ratio of charge/discharge capability, will be dramatically increased.

Among different densities, changing the compacted density of cathode nanomaterials to a suitable value can increase their charge capacity, decrease the internal resistance, lower the polarization effect, increase cycling life of electrical energy storage devices, and improve the usability of electrical energy storage devices. It is important to find the optimum compacted density for the electronic energy storage device design. If the compacted density is too large or too small, the intercalation and de-intercalation of ions will be affected. In general, compacted density is in a positive correlation to the device's specific capacity, and is considered as one of the key parameters for material energy density.

Rolling density affects the electrochemical performance characteristics of cathode nanomaterials in a similar way. Rolling density indicates the ratio of the mass of coating slurry compound to its volume. Rolling density is a valuable quantity not only for evaluating the volumetric energy density, but also for selecting a cathode nanomaterial candidate for Hybrid-Electric Vehicles (also known as HEVs) and Electric Vehicles (also known as EVs).

Both of these two types of properties need to be considered in the density assessment of a nano-enabled electrical energy storage device. Comparable results will be used to judge the consistence of cathode nanomaterials, which relates to performance and safety issues. Therefore, a standardized density measurement procedure for cathode nanomaterials becomes indispensable to its users for comparing the values of nanomaterials from different suppliers.

This standardized method is intended for use in comparing the characteristics of cathode nanomaterials in the study stage, not for evaluating the electrode in end-products. The method is applicable to materials exhibiting function or performance only possible with nanotechnology, intentionally added to the active materials to measurably and significantly change the characteristics of electrical energy storage devices.

NANOMANUFACTURING – KEY CONTROL CHARACTERISTICS –

Part 4-2: Nano-enabled electrical energy storage – Physical characterization of cathode nanomaterials, density measurement

1 Scope

This part of IEC 62607, which is a Technical Specification, provides a standardized method for the determination of the density of cathode nanomaterials in powder form used for electrical energy storage devices. This method provides users with a key control characteristic to decide whether or not a cathode nanomaterial is usable, or suitable for their application.

This document includes

- definitions of terminology used in this document,
- recommendations for sample preparation,
- outlines of the experimental procedures used to measure cathode nanomaterial properties,
- methods of interpretation of results and discussion of data analysis,
- case studies, and
- references.

2 Normative references

The following documents are referred to in the text in such a way that some or all of their content constitutes requirements of this document. For dated references, only the edition cited applies. For undated references, the latest edition of the referenced document (including any amendments) applies.

ISO/TS 80004-1, *Nanotechnologies – Vocabulary – Part 1: Core terms*

3 Terms, definitions, and abbreviated terms

3.1 Terms and definitions

For the purposes of this document, the terms and definitions given in ISO/TS 80004-1 and the following apply.

ISO and IEC maintain terminological databases for use in standardization at the following addresses:

- IEC Electropedia: available at <http://www.electropedia.org/>
- ISO Online browsing platform: available at <http://www.iso.org/obp>

3.1.1

cathode nanomaterial

material used as a cathode in a nano-enabled energy storage device which contains a fraction of nanomaterial and exhibits function or performance made possible only with the application of nanotechnology

Note 1 to entry: The cathode is a multilayered foil consisting of (1) an aluminium current collector, (2) an optional adhesion promoting carbon layer (to enhance cathode layer adhesion if necessary) and (3) the cathode layer. This cathode layer consists of the active phase (e.g. lithium containing mixed oxides or phosphate, such as LFP), a conducting phase (carbon black) and an organic binder (PVDF).

3.1.2

compacted density

ratio of the mass of powder to the volume it occupies after it has been subjected to compression under a certain pressure

3.1.3

rolling density

ratio of the mass of the rolled active material to its volume after being coated on a substrate

3.1.4

die

tool designed for containing and forming the powdered samples during compression, which is made from hard materials (e.g. tungsten carbide)

Note 1 to entry: A die is usually in a cylinder shape and contains two punches for producing compacts, and is of the floating type or of the type suspended from a spring, in order to ensure dual action pressure.

3.1.5

press

mechanical device designed for generating and applying pressure upon the die to compress the sample, which is capable of applying sufficient force to the die surface with an accuracy of ± 1 %

3.2 Abbreviated terms

LFP lithium iron phosphate, LiFePO_4

PVDF polyvinylidene fluoride

4 Sample preparation methods

4.1 Sieving

Sample should be homogeneous particulate powder with uniform sizes. If big chunks or large agglomerates exist, they should be removed by sieving (150 mesh) in order to avoid cracking, delamination and local ununiformity in the compacted density.

4.2 Drying

Dry the sample in an oven at a temperature above 100 °C until dry. For example, one drying protocol may consist of two hours in an oven at 105 °C. However, other samples may require longer time to be sufficiently dry for use in nano-enabled electrical energy storage devices.

5 Test methods

5.1 Compacted density

5.1.1 General

Weigh the desired mass of sample, place the sample in the die (The parameters and tolerances are indicated in Figure A.1 and engineering drawing is shown in Figure A.2 in Annex A.), and then put the die in the middle of the power compressor. Adjust the settings on the powder compressor until the desired pressure is reached. Maintain the pressure for a certain duration, then take out the cylindrical sample and measure its height. The compacted density is calculated by dividing the mass of cathode nanomaterials by the volume.

5.1.2 Apparatus

5.1.2.1 Analytical balance

The analytical balance used shall have a resolution of 0,01 g.

5.1.2.2 Powder compressor

The powder compressor consists of two parts:

- a) a die, having the three-dimensional appearance shown in Figure A.1 and Figure A.2;
- b) a die compressor, having the appearance shown in Figure 2.

5.1.2.3 Vernier caliper

The resolution of an appropriate vernier caliper used should be 0,02 mm.

5.1.3 Measurement steps

Measurement steps are as follows:

- a) Turn on the electronic balance, weigh a certain mass of sample (suggested range: 1 g to 10 g and record the mass (m) in grams. Care should be taken to ensure that the change of m during sample transfer and density measurement is minimal.
- b) Take out the die from the powder compressor and clean it with dustless paper, transfer the weighed sample into the die (if it cannot be filled all at once, do it as many times as necessary), make sure the powder is evenly distributed in the die, then cap the die (Figure 1).
- c) Gently place the die in the middle of the compressor and fix the hand wheel clockwise. Increase the pressure to the desired setting (the value can vary depending on the type of powder, such as particle size, shape. For LFP, it is suggested to be 10 MPa to 20 MPa, which is defined by the integrity of the sample cylinder). Maintain the pressure for 1 min to 2 min, and then release the pressure slowly.
- d) Take out the die (Figure 2) and then take out the sample – the sample should be a cylinder; measure the height (h) and diameter (d) using the vernier caliper and record h and d in millimetres.

In case of nanomaterials with which it is difficult to form intact cylinders, it is recommended to measure the sample height when it is still with the upper and lower pads, and then obtain the value by subtracting the predetermined pad heights.

5.1.4 Data analysis / interpretation of results

Compacted density is calculated by Formula (1):

$$\rho = \frac{m}{v} = \frac{4m}{\pi d^2 h \times 10^{-3}} \quad (1)$$

where

ρ is the compacted density, g/cm³;

m is the mass of the powder, g;

v is the volume of powder after compression, cm³;

π is the ratio of the circumference of a circle to the diameter;

d is the diameter of sample cylinder, mm;

h is the height of sample after compaction, mm.

Perform three individual measurements for the same sample, and then take the arithmetical average value if they pass the repeatability test, and report the final result, precise to $0,1 \text{ g/cm}^3$.



IEC

Figure 1 – Appearance of die for compacted density measurement



IEC

Figure 2 – Appearance of die with compressor

5.1.5 Precision of the method

5.1.5.1 Repeatability

The results of three independent single test results, obtained using the same method on identical testing material in the same laboratory by the same operator using the same equipment within a short interval of time, should not differ by more than 2 % of the arithmetic average of the three results.

Reject the results if the difference exceeds the indicated repeatability value and carry out new determinations.

5.1.5.2 Reproducibility

The average results of the duplicate tests, obtained using the same method on identical materials in each of two laboratories' testing materials, are expected to agree within 5 %.

5.2 Rolling density

5.2.1 General

Bind the cathode active materials to form a paste with a suitable viscosity. Coat the paste on the substrate (aluminium) followed by drying until the solvent is completely evaporated. And then the electrode composite is pressed through the rolling machine. Punch the rolled electrode composite in a certain area (configuration as shown in Figure A.6, step B). Rolling

density will be obtained by calculating the mass of cathode materials over the volume after rolling.

5.2.2 Apparatus

5.2.2.1 Balance

The balance used in the experiment should be capable of weighing to within $\pm 0,01$ g.

5.2.2.2 Micrometer

The micrometer used in the experiment should be capable of measuring to within $\pm 0,001$ mm.

5.2.2.3 Coating machine

The coating machine is shown in Figure A.6, step A.

5.2.2.4 Rolling machine

The rolling machine is shown in Figure A.6, step B.

5.2.3 Measurement steps

Measurement steps are as follows:

- a) Mix the cathode active material with a suitable amount of binder and conductive materials in water or NMP (1-Methyl-2-pyrrolidinone), etc. as the solvent, stir the mixture to form a suitable viscosity paste.
- b) Inject the paste into the coating machine and uniformly coat the paste on the substrate (aluminium) and then dry. This procedure should be conducted below a certain humidity as humidity may influence the property of coating. For LFP to be mixed into NMP, the humidity should be controlled in the range 0 % to 50 %.
- c) Rolling process: Place the cathode into the groove of the rolling machine to form the rolled cathode.
- d) Measurement: Select the shape and size of the cathode electrode and substrate – area (symbol: s), mass (symbol: $m_{\text{Electrode}}$ and $m_{\text{Substrate}}$), thickness (symbol: $h_{\text{Electrode}}$ and $h_{\text{Substrate}}$), respectively.

5.2.4 Data analysis / interpretation of results

Rolling density is calculated by Formula (2):

$$\rho = \frac{m}{v} = \frac{m_{\text{Electrode}} - m_{\text{Substrate}}}{s(h_{\text{Electrode}} - h_{\text{Substrate}}) \times 10^{-3}} \quad (2)$$

where

- | | |
|------------------------|--|
| ρ | is the rolling density, g/cm ³ ; |
| m | is the powder mass of cathode electrode, g; |
| v | is the powder volume of cathode electrode after rolling, cm ³ ; |
| $m_{\text{Electrode}}$ | is the mass of cathode electrode, g; |
| $m_{\text{Substrate}}$ | is the mass of cathode substrate, g; |
| s | is the area of cathode electrode after rolling, mm ² ; |
| $h_{\text{Electrode}}$ | is the thickness of cathode electrode after rolling, mm; |
| $h_{\text{Substrate}}$ | is the thickness of cathode substrate, mm. |

The final results shall be the arithmetic average value after three measurements, precise to $0,1 \text{ g/cm}^3$.

5.2.5 Repeatability of the method

The results of three independent single tests, obtained using the same method on identical testing material in the same laboratory by the same operator using the same equipment within a short interval of time, should not differ by more than 2 % of the arithmetic average of the three results.

Reject the results if the difference exceeds the indicated repeatability value and carry out new determinations.

6 Uncertainty

Currently, the uncertainties associated with measuring the compacted and rolling densities of cathode nanomaterials should be estimated from various origins as listed below:

- a) uncertainties associated with weighing the mass of the powder, which include the balance calibration, weighing operation, and spills when transferring the sample;
- b) uncertainties associated with measuring the volume of the compressed and rolled sample, which include caliper calibration, inhomogeneity in disc flatness, and baseline determination.

Annex A (informative)

Case study

A.1 Sample preparation

A.1.1 Schematic figures of die for measuring compacted density and rolling density

Schematic figures of die and rolling machine are shown in Figures A.1 to A.3.

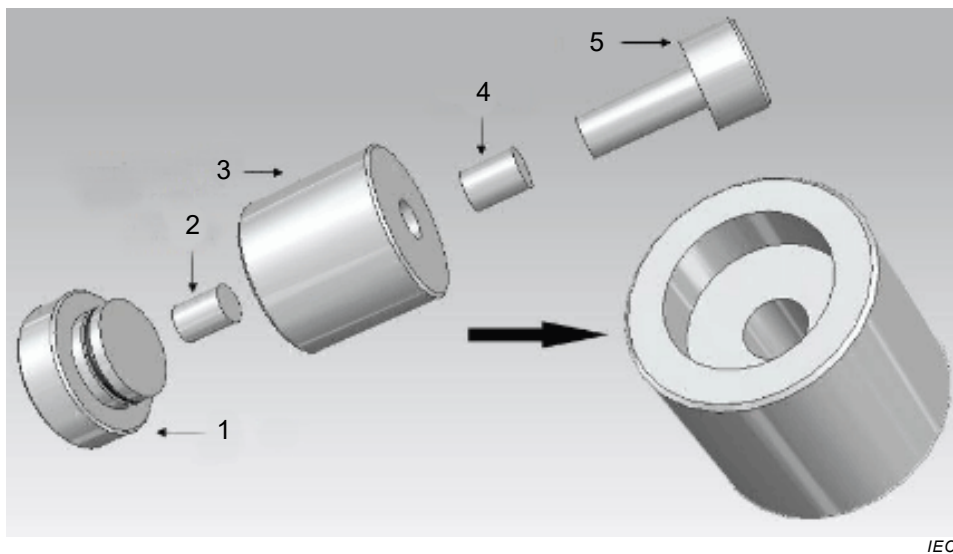

Key

- 1 die base
- 2 lower pad
- 3 sample container
- 4 upper pad
- 5 punch

Figure A.1 – Three-dimensional schematic of die for compacted density measurement

Dimensions in millimetres

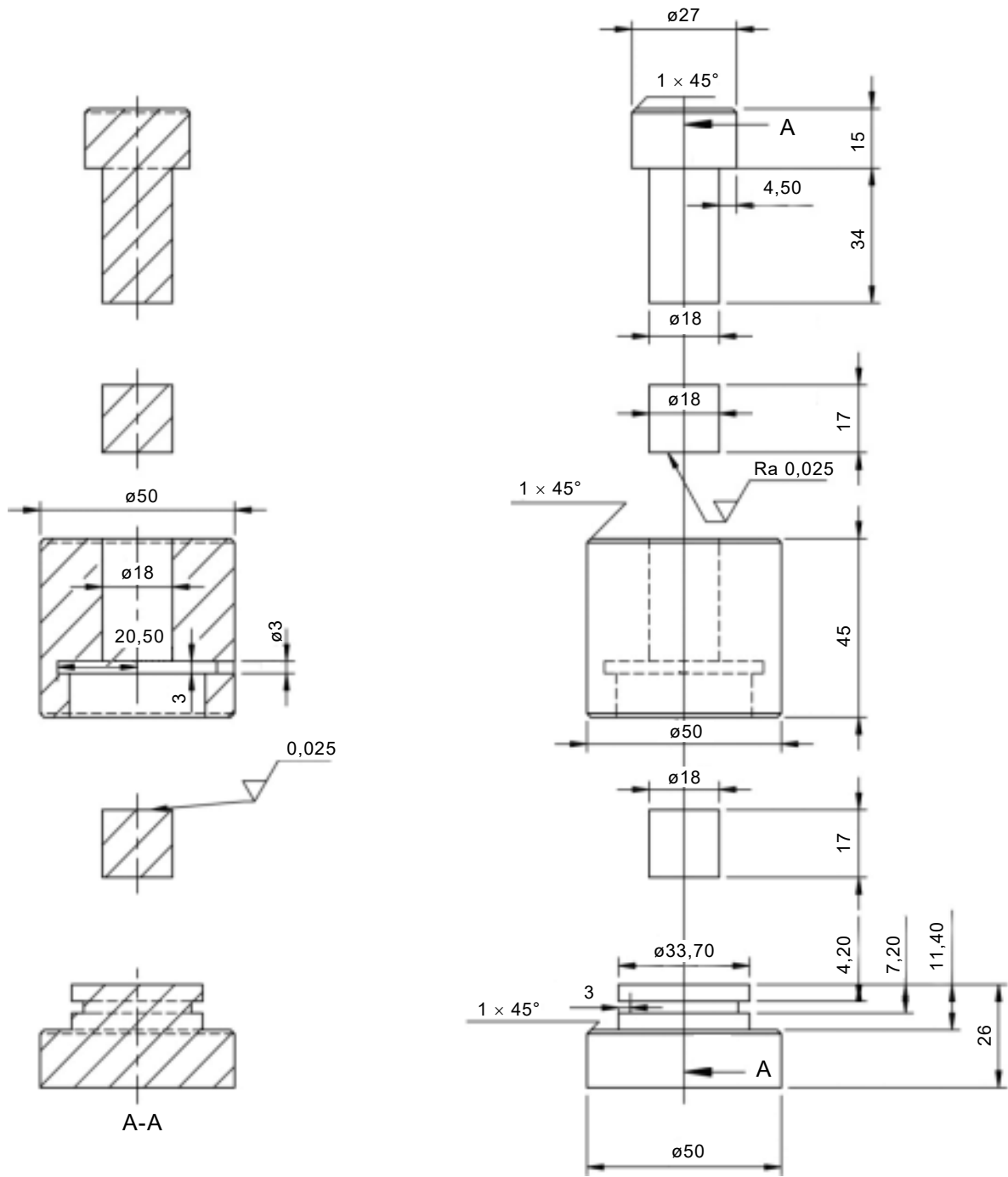

IEC

Figure A.2 – Engineering schematic of die for compacted density measurement

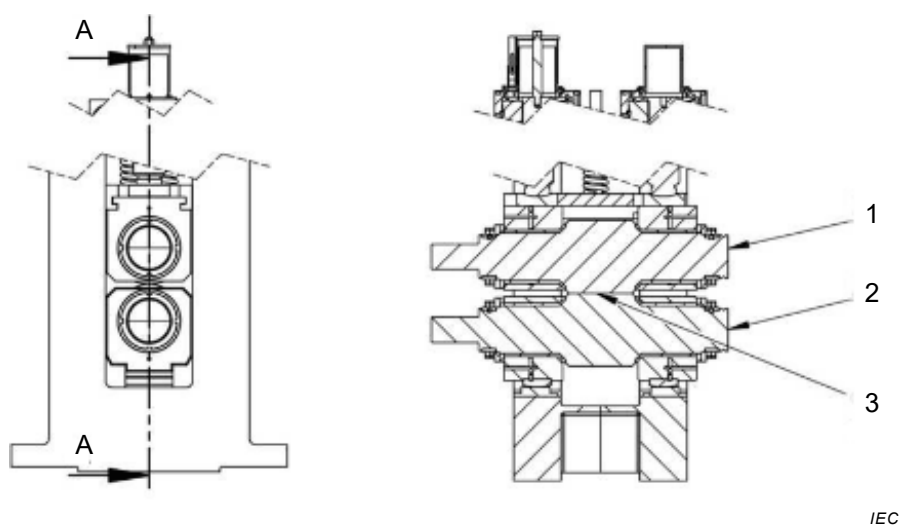

Key

- 1 upper roller
- 2 bottom roller

^a Cathode sheet is condensed through the gap by rolling.

Figure A.3 – Schematic of rolling machine for rolling density measurement

A.1.2 Compacted density measurement results for LFP nanomaterial

Measurement results for sample A are given in Table A.1 and represented graphically in Figure A.4.

Table A.1 – Measurement method consistency and measurement results of sample A

Sample	No.	Mass (g)	Compacted density (g/cm ³)	Average value (g/cm ³)	Absolute deviation (g/cm ³)	Relative deviation (%)	Standard deviation (g/cm ³)
Sample A	1	4,00	1,93	1,94	-0,01	0,52	0,010
	2	4,00	1,94		0	0	
	3	4,00	1,95		0,01	0,52	
Sample A	4	2,50	1,92	1,92	0	0	0,007
	5	2,50	1,92		0	0	
	6	2,50	1,91		-0,01	0,52	

Results from Table A.1 show that the deviation of compacted density in different measurements of sample A is lower than 2 % and 5 %.

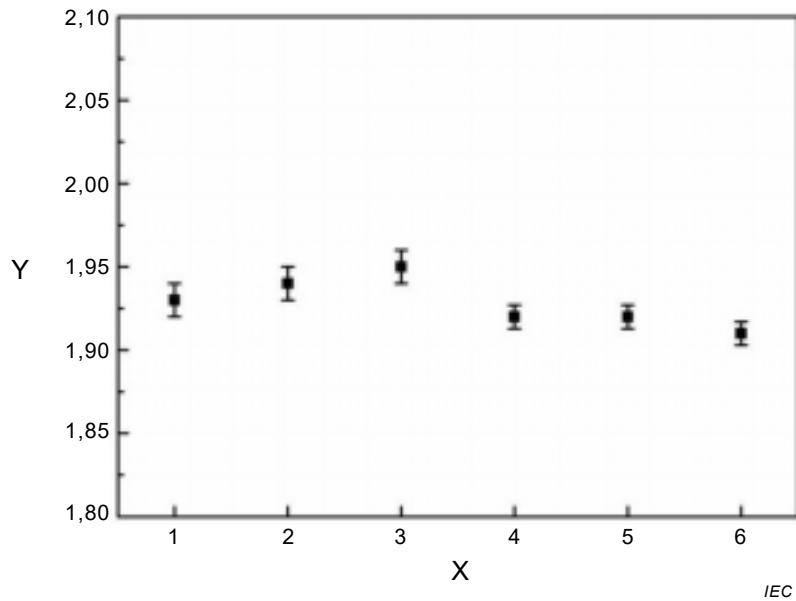

X index of experiments

Y compacted density (g/cm³)

Figure A.4 – Results consistency of sample A in Table A.1

Measurement results for sample B are given in Table A.2 and represented graphically in Figure A.5.

Table A.2 – Measurement method consistency and measurement results of sample B

Sample	No.	Mass (g)	Compacted density (g/cm³)	Average value (g/cm³)	Absolute deviation (g/cm³)	Relative deviation (%)	Standard deviation (g/cm³)
Sample B	1	4,00	2,40	2,42	-0,02	0,83	0,017
	2	4,00	2,43		0,01	0,41	
	3	4,00	2,43		0,01	0,41	
Sample B	4	2,51	2,42	2,41	0,01	0,41	0,012
	5	2,51	2,40		-0,01	0,41	
	6	2,50	2,42		0,01	0,41	

Results from Table A.2 show that the deviation of compacted density in different measurements of sample B is lower than 2 % and 5 %.

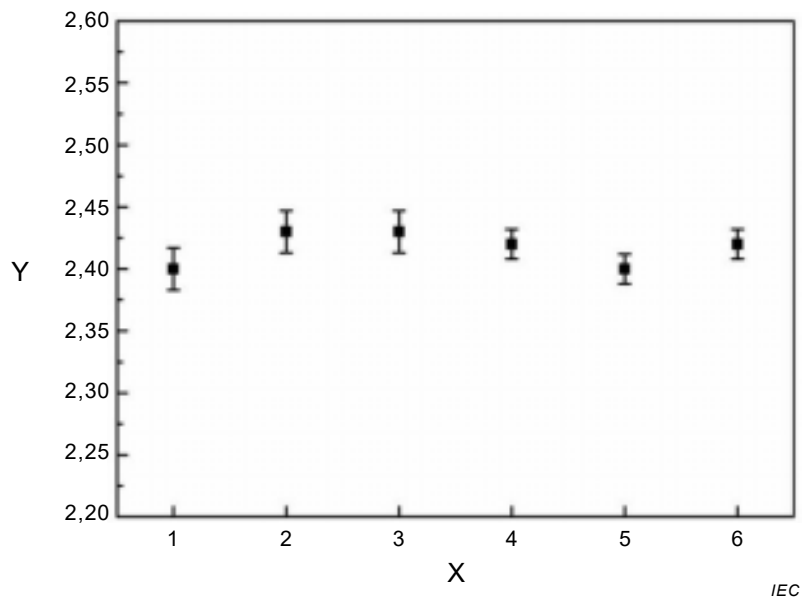

X index of experiments

Y compacted density (g/cm³)

Figure A.5 – Results consistency of sample B in Table A.2

A.2 Rolling density sample preparation case study

A.2.1 Procedures of rolling density sample preparation

Procedures of rolling density sample preparation are shown in Figure A.6.





Step	Figure	Description
A	 <p>Figure A shows three photographs. The top-left photo shows a coating machine with a substrate being processed. The top-right photo shows a person's hands holding a long, narrow, dark grey substrate. The bottom-left photo shows a close-up of the coating machine's rollers. The bottom-right photo shows a person's hands holding a dark grey substrate, similar to the one in the top-right photo.</p> <p style="text-align: right;"><i>IEC</i></p>	<p>Injecting paste into coating machine and coating the paste on the substrate (aluminium) uniformly and then drying.</p>
B	 <p>Figure B shows four photographs. The top-left photo shows a rolling machine with a substrate being processed. The top-right photo shows a person's hands holding a dark grey substrate. The bottom-left photo shows a dark grey substrate being held. The bottom-right photo shows a person's hands using a tool to punch a circular hole into a dark grey substrate.</p> <p style="text-align: right;"><i>IEC</i></p>	<p>Placing the cathode into the groove of rolling machine to form the rolled cathode. Then punching the rolled cathode in a certain area.</p>
C	 <p>Figure C shows two photographs of an electronic balance. The left photo shows a person's hands placing a dark grey circular cathode onto the balance's weighing pan. The right photo shows the balance's display screen showing a reading of 00.159 g.</p> <p style="text-align: right;"><i>IEC</i></p>	<p>Weighing the weight of the rolled cathode with an electronic balance.</p>
D	 <p>Figure D shows two photographs of a micrometer. The left photo shows the micrometer's display screen showing a reading of 0000. The right photo shows a person's hands using the micrometer to measure the thickness of a dark grey circular cathode.</p> <p style="text-align: right;"><i>IEC</i></p>	<p>Measuring the thickness of rolled cathode with a micrometer.</p>

Figure A.6 – Procedures of rolling density sample preparation

A.2.2 Rolling density measurement results for LFP nanomaterial

Measurement results for sample C are given in Table A.3 and represented graphically in Figure A.7.

Table A.3 – Measurement method consistency and measurement results of sample C

Sample	No.	Mass (g)	Area (mm ²)	Thickness of electrode (mm)	Thickness of substrate (mm)	Rolling density (g/cm ³)	Average value (g/cm ³)	Absolute deviation (g/cm ³)	Relative deviation (%)	Standard deviation (g/cm ³)
Sample C (rectangular electrode)	1	10,25	35 750	0,150	0,020	2,21	2,20	0,01	0,45	0,010
	2	10,27	35 750	0,151	0,020	2,19		-0,01	0,45	
	3	10,28	35 750	0,151	0,020	2,20		0	0	
Sample C (circular electrode)	4	8,99	31 400	0,149	0,020	2,22	2,21	0,01	0,45	0,007
	5	9,01	31 400	0,150	0,020	2,21		0	0	
	6	9,03	31 400	0,150	0,020	2,21		0	0	

Results from Table A.3 show that the deviation of compacted density in different measurements of sample C is lower than 2 %.

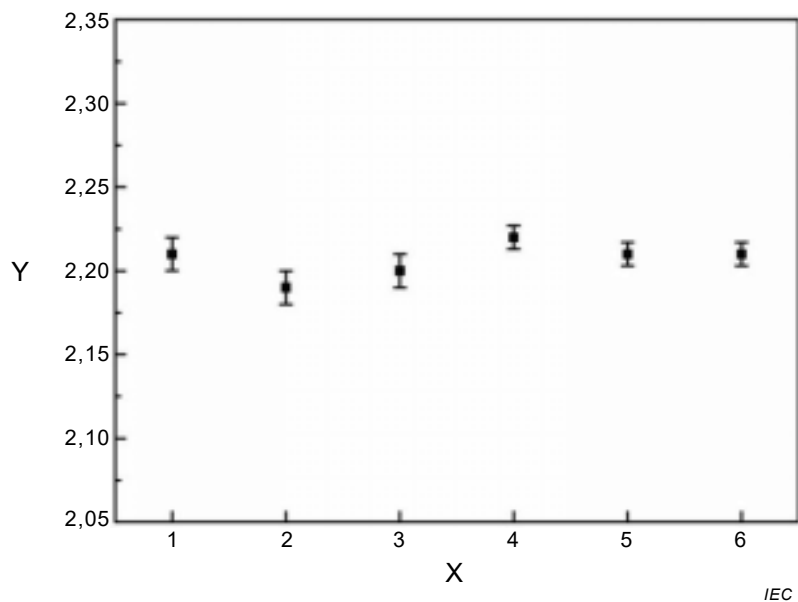

X index of experiments

Y rolling density (g/cm³)

Figure A.7 – Results consistency of sample C in Table A.3

Bibliography

ISO 5072, *Brown coals and lignites – Determination of true relative density and apparent relative density*

ISO 6770, *Instant tea – Determination of free-flow and compacted bulk densities*

ISO 8460, *Instant coffee – Determination of free-flow and compacted bulk densities*

G.W. Ling, X.P. Zhu, Y.B. He et al., Structural and thermal stabilities of spinel LiMn_2O_4 materials under commercial power batteries cycling and abusive conditions, *Int. J. Electrochem. Sci.* (2012) 7:2455-2467

A.O. Kurt, T.J. Davies, *A study of compaction of metal powders*, 493-506

Z.L. Lin, X.H. Zhang, L. Hong, Preparation and electrochemical properties of spherical LiFePO_4 and $\text{LiFe}_{0.9}\text{Mg}_{0.1}\text{PO}_4$ cathode materials for lithium rechargeable batteries, *J. Appl. Electrochem.* (2009) 39:2433-2438

T. Ruth, A model for the evaluation of uncertainty in routine multi-element analysis, *Accred. Qual. Assur.* (2004) 9: 349-354

British Standards Institution (BSI)

BSI is the national body responsible for preparing British Standards and other standards-related publications, information and services.

BSI is incorporated by Royal Charter. British Standards and other standardization products are published by BSI Standards Limited.

About us

We bring together business, industry, government, consumers, innovators and others to shape their combined experience and expertise into standards-based solutions.

The knowledge embodied in our standards has been carefully assembled in a dependable format and refined through our open consultation process. Organizations of all sizes and across all sectors choose standards to help them achieve their goals.

Information on standards

We can provide you with the knowledge that your organization needs to succeed. Find out more about British Standards by visiting our website at bsigroup.com/standards or contacting our Customer Services team or Knowledge Centre.

Buying standards

You can buy and download PDF versions of BSI publications, including British and adopted European and international standards, through our website at bsigroup.com/shop, where hard copies can also be purchased.

If you need international and foreign standards from other Standards Development Organizations, hard copies can be ordered from our Customer Services team.

Copyright in BSI publications

All the content in BSI publications, including British Standards, is the property of and copyrighted by BSI or some person or entity that owns copyright in the information used (such as the international standardization bodies) and has formally licensed such information to BSI for commercial publication and use.

Save for the provisions below, you may not transfer, share or disseminate any portion of the standard to any other person. You may not adapt, distribute, commercially exploit, or publicly display the standard or any portion thereof in any manner whatsoever without BSI's prior written consent.

Storing and using standards

Standards purchased in soft copy format:

- A British Standard purchased in soft copy format is licensed to a sole named user for personal or internal company use only.
- The standard may be stored on more than 1 device provided that it is accessible by the sole named user only and that only 1 copy is accessed at any one time.
- A single paper copy may be printed for personal or internal company use only.

Standards purchased in hard copy format:

- A British Standard purchased in hard copy format is for personal or internal company use only.
- It may not be further reproduced – in any format – to create an additional copy. This includes scanning of the document.

If you need more than 1 copy of the document, or if you wish to share the document on an internal network, you can save money by choosing a subscription product (see 'Subscriptions').

Reproducing extracts

For permission to reproduce content from BSI publications contact the BSI Copyright & Licensing team.

Subscriptions

Our range of subscription services are designed to make using standards easier for you. For further information on our subscription products go to bsigroup.com/subscriptions.

With **British Standards Online (BSOL)** you'll have instant access to over 55,000 British and adopted European and international standards from your desktop. It's available 24/7 and is refreshed daily so you'll always be up to date.

You can keep in touch with standards developments and receive substantial discounts on the purchase price of standards, both in single copy and subscription format, by becoming a **BSI Subscribing Member**.

PLUS is an updating service exclusive to BSI Subscribing Members. You will automatically receive the latest hard copy of your standards when they're revised or replaced.

To find out more about becoming a BSI Subscribing Member and the benefits of membership, please visit bsigroup.com/shop.

With a **Multi-User Network Licence (MUNL)** you are able to host standards publications on your intranet. Licences can cover as few or as many users as you wish. With updates supplied as soon as they're available, you can be sure your documentation is current. For further information, email subscriptions@bsigroup.com.

Revisions

Our British Standards and other publications are updated by amendment or revision.

We continually improve the quality of our products and services to benefit your business. If you find an inaccuracy or ambiguity within a British Standard or other BSI publication please inform the Knowledge Centre.

Useful Contacts

Customer Services

Tel: +44 345 086 9001

Email (orders): orders@bsigroup.com

Email (enquiries): cservices@bsigroup.com

Subscriptions

Tel: +44 345 086 9001

Email: subscriptions@bsigroup.com

Knowledge Centre

Tel: +44 20 8996 7004

Email: knowledgecentre@bsigroup.com

Copyright & Licensing

Tel: +44 20 8996 7070

Email: copyright@bsigroup.com

BSI Group Headquarters

389 Chiswick High Road London W4 4AL UK