



BSI Standards Publication

# Recommendations for renewable energy and hybrid systems for rural electrification

Part 5: Protection against  
electrical hazards

### **National foreword**

This Published Document is the UK implementation of IEC/TS 62257-5:2015. It supersedes DD IEC/TS 62257-5:2005 which is withdrawn.

The UK participation in its preparation was entrusted to Technical Committee GEL/82, Photovoltaic Energy Systems.

A list of organizations represented on this committee can be obtained on request to its secretary.

This publication does not purport to include all the necessary provisions of a contract. Users are responsible for its correct application.

© The British Standards Institution 2016.

Published by BSI Standards Limited 2016

ISBN 978 0 580 89917 1

ICS 27.160; 27.180

**Compliance with a British Standard cannot confer immunity from legal obligations.**

This Published Document was published under the authority of the Standards Policy and Strategy Committee on 31 January 2016.

### **Amendments/corrigenda issued since publication**

<b>Date</b>	<b>Text affected</b>
-------------	----------------------

---



# TECHNICAL SPECIFICATION



---

**Recommendations for renewable energy and hybrid systems for rural  
electrification –  
Part 5: Protection against electrical hazards**

INTERNATIONAL  
ELECTROTECHNICAL  
COMMISSION

---

ICS 27.160

ISBN 978-2-8322-3070-1

**Warning! Make sure that you obtained this publication from an authorized distributor.**

## CONTENTS

FOREWORD .....	5
INTRODUCTION .....	7
1 Scope .....	8
2 Normative references .....	8
3 Terms and definitions .....	9
4 Classification of decentralised rural electrification systems .....	11
5 Protection against electric shock .....	11
5.1 General .....	11
5.2 Requirements on the d.c. side of a DRES .....	11
5.3 Requirements on the a.c. side of a DRES .....	12
5.3.1 General .....	12
5.3.2 TT system .....	12
5.3.3 TN system .....	12
6 Protection against overcurrent .....	13
6.1 General .....	13
6.2 Protection against overload currents .....	13
6.3 Protection against short-circuits .....	13
7 Protection against risk of fire .....	13
8 Protection against effects of lightning .....	14
8.1 Principle .....	14
8.2 Examples .....	14
8.3 Protection against overvoltage .....	14
8.4 Protection against direct lightning .....	14
9 Determination of the pick up area of a rod or wire (see IEC 62305-3:2010) .....	14
9.1 General .....	14
9.2 Operational conditions and external influences .....	14
9.3 Wiring system .....	15
9.4 Isolation and switching .....	15
9.4.1 Isolation .....	15
9.4.2 Over-current protective devices .....	16
9.4.3 Residual Current Devices (RCD) .....	17
9.5 Surge protective devices .....	17
9.6 Earthing arrangement, protective conductors and protective bonding conductors .....	18
9.6.1 Earth electrodes .....	18
9.6.2 Protective bonding conductors .....	19
10 Verification .....	19
11 Operation and maintenance .....	19
Annex A (informative) Protection against electric shock in electrical installations .....	20
A.1 Protection against electric shock .....	20
A.2 Automatic disconnection of supply .....	20
A.2.1 General .....	20
A.2.2 In TN systems .....	21
A.2.3 In TT systems .....	21
A.3 Double or reinforced insulation .....	22

A.4	Extra-low-voltage (SELV and PELV) .....	22
A.5	Electrical separation .....	22
A.6	Additional protection .....	23
Annex B (informative)	Types of LV distribution systems earthing .....	24
B.1	Terms and definitions.....	24
B.2	Types of system earthing used in DRES (Figures are from IEC 60364-1:2005) .....	25
B.2.1	General .....	25
B.2.2	AC TN systems.....	27
B.2.3	AC TT systems .....	34
B.2.4	DC distribution systems .....	36
Annex C (informative)	Classification of electrical equipment .....	41
C.1	Classification of residual current devices (RCDs) (see IEC 61008, IEC 61009, IEC 60755, IEC 60947-2, IEC 62423) .....	41
C.2	Classification of circuit breakers for a.c. operation (see IEC 60898-1, IEC 60947-2) .....	42
C.3	Classification of surge protective devices (see IEC 61643-11) .....	43
Annex D (informative)	General information concerning protection against lightning .....	44
D.1	General.....	44
D.2	Protection against lightning – Principles.....	45
Bibliography	.....	46
Figure B.1	– General outline of the distribution system .....	24
Figure B.2	– Distribution system of the smallest type .....	25
Figure B.3	– TN-S system 3-phase, 4-wire with separate neutral conductor and protective conductor throughout the distribution system .....	28
Figure B.4	– TN-S system 3-phase, 3-wire with separate earthed line conductor and protective conductor throughout the distribution system .....	29
Figure B.5	– TN-S system 3-phase, 3-wire with protective conductor and no distributed neutral conductor throughout the distribution system .....	30
Figure B.6	– TN-C-S system 3-phase, 4-wire where the PEN conductor is separated into the protective conductor PE and the neutral conductor N elsewhere in the electrical installation .....	31
Figure B.7	– TN-C-S system 3-phase, 4-wire where the PEN conductor is separated into the protective conductor PE and the neutral conductor N at the origin of the electrical installation .....	32
Figure B.8	– TN-C-S system – single-phase, 2-wire where the PEN conductor is separated into the protective conductor PE and the neutral conductor N at the origin of the electrical installation .....	32
Figure B.9	– TN-C system 3-phase, 4-wire with neutral and protective conductor functions combined in a single conductor throughout the distribution system .....	33
Figure B.10	– TN-S multiple source system 3-phase, 4-wire with separate protective conductor and neutral conductor to current using equipment.....	34
Figure B.11	– TT system 3-phase, 4-wire with earthed protective conductor and neutral conductor throughout the distribution system .....	35
Figure B.12	– TT system 3-phase, 3-wire with earthed protective conductor and no distributed neutral conductor throughout the distribution system .....	35
Figure B.13	– TN-S d.c. system .....	37
Figure B.14	– TN-C d.c. system .....	38
Figure B.15	– TN-C-S d.c. system.....	39

Figure B.16 – TT d.c. system .....	40
Figure D.1 – Example of effects of a lightning stroke .....	44
Table 1 – Typology of decentralized electrification systems .....	11
Table 2 – Rated operating residual current of the protective device depending on the value of the earthing resistance .....	12
Table 3 – Number of protected poles with regard to the characteristics of the distribution system .....	16

## INTERNATIONAL ELECTROTECHNICAL COMMISSION

**RECOMMENDATIONS FOR RENEWABLE ENERGY  
AND HYBRID SYSTEMS FOR RURAL ELECTRIFICATION –****Part 5: Protection against electrical hazards**

## FOREWORD

- 1) The International Electrotechnical Commission (IEC) is a worldwide organization for standardization comprising all national electrotechnical committees (IEC National Committees). The object of IEC is to promote international co-operation on all questions concerning standardization in the electrical and electronic fields. To this end and in addition to other activities, IEC publishes International Standards, Technical Specifications, Technical Reports, Publicly Available Specifications (PAS) and Guides (hereafter referred to as “IEC Publication(s)”). Their preparation is entrusted to technical committees; any IEC National Committee interested in the subject dealt with may participate in this preparatory work. International, governmental and non-governmental organizations liaising with the IEC also participate in this preparation. IEC collaborates closely with the International Organization for Standardization (ISO) in accordance with conditions determined by agreement between the two organizations.
- 2) The formal decisions or agreements of IEC on technical matters express, as nearly as possible, an international consensus of opinion on the relevant subjects since each technical committee has representation from all interested IEC National Committees.
- 3) IEC Publications have the form of recommendations for international use and are accepted by IEC National Committees in that sense. While all reasonable efforts are made to ensure that the technical content of IEC Publications is accurate, IEC cannot be held responsible for the way in which they are used or for any misinterpretation by any end user.
- 4) In order to promote international uniformity, IEC National Committees undertake to apply IEC Publications transparently to the maximum extent possible in their national and regional publications. Any divergence between any IEC Publication and the corresponding national or regional publication shall be clearly indicated in the latter.
- 5) IEC itself does not provide any attestation of conformity. Independent certification bodies provide conformity assessment services and, in some areas, access to IEC marks of conformity. IEC is not responsible for any services carried out by independent certification bodies.
- 6) All users should ensure that they have the latest edition of this publication.
- 7) No liability shall attach to IEC or its directors, employees, servants or agents including individual experts and members of its technical committees and IEC National Committees for any personal injury, property damage or other damage of any nature whatsoever, whether direct or indirect, or for costs (including legal fees) and expenses arising out of the publication, use of, or reliance upon, this IEC Publication or any other IEC Publications.
- 8) Attention is drawn to the Normative references cited in this publication. Use of the referenced publications is indispensable for the correct application of this publication.
- 9) Attention is drawn to the possibility that some of the elements of this IEC Publication may be the subject of patent rights. IEC shall not be held responsible for identifying any or all such patent rights.

The main task of IEC technical committees is to prepare International Standards. In exceptional circumstances, a technical committee may propose the publication of a technical specification when

- the required support cannot be obtained for the publication of an International Standard, despite repeated efforts, or
- the subject is still under technical development or where, for any other reason, there is the future but no immediate possibility of an agreement on an International Standard.

Technical specifications are subject to review within three years of publication to decide whether they can be transformed into International Standards.

IEC 62257-5, which is a technical specification, has been prepared by IEC technical committee 82: Solar photovoltaic energy systems.

This second edition cancels and replaces the first edition issued in 2005. It constitutes a technical revision.

The main technical changes with regard to the previous edition are as follows:

- redefine the maximum AC voltage from 500 V to 1 000 V, the maximum DC voltage from 750 V to 1 500 V;
- removal of the limitation of 100 kVA system size. Hence the removal of the word “small” in the title and related references in this technical specification.

This technical specification is to be used in conjunction with the IEC 62257 series (specifically IEC TS 62257-1 to IEC TS 62257-6).

The text of this technical specification is based on the following documents:

Enquiry draft	Report on voting
82/950/DTS	82/1001A/RVC

Full information on the voting for the approval of this technical specification can be found in the report on voting indicated in the above table.

This publication has been drafted in accordance with the ISO/IEC Directives, Part 2.

A list of all parts in the IEC 62257 series, published under the general title *Recommendations for renewable energy and hybrid systems for rural electrification*, can be found on the IEC website.

Future standards in this series will carry the new general title as cited above. Titles of existing standards in this series will be updated at the time of the next edition.

The committee has decided that the contents of this publication will remain unchanged until the stability date indicated on the IEC website under "<http://webstore.iec.ch>" in the data related to the specific publication. At this date, the publication will be

- transformed into an International standard,
- reconfirmed,
- withdrawn,
- replaced by a revised edition, or
- amended.

A bilingual version of this publication may be issued at a later date.

**IMPORTANT – The 'colour inside' logo on the cover page of this publication indicates that it contains colours which are considered to be useful for the correct understanding of its contents. Users should therefore print this document using a colour printer.**



## INTRODUCTION

The IEC 62257 series intends to provide to different players involved in rural electrification projects (such as project implementers, project contractors, project supervisors, installers, etc.) documents for the setting up of renewable energy and hybrid systems with AC voltage below 1 000 V and DC voltage below 1 500 V.

These documents are recommendations:

- to choose the right system for the right place;
- to design the system;
- to operate and maintain the system.

These documents are focused only on rural electrification, concentrating on, but not specific to developing countries. They should not be considered as all inclusive to rural electrification. The documents try to promote the use of renewable energies in rural electrification; they do not deal with clean mechanisms developments at this time (CO<sub>2</sub> emission, carbon credit, etc.). Further developments in this field could be introduced in future steps.

This consistent set of documents is best considered as a whole with different parts corresponding to items for safety, sustainability of systems aiming at the lowest life cycle cost as possible. One of the main objectives is to provide the minimum sufficient requirements, relevant to the field of application, that is: renewable energy and hybrid off-grid systems.

# RECOMMENDATIONS FOR RENEWABLE ENERGY AND HYBRID SYSTEMS FOR RURAL ELECTRIFICATION –

## Part 5: Protection against electrical hazards

### 1 Scope

This part of IEC 62257 specifies the general requirements for the protection of persons and equipment against electrical hazards to be applied in decentralised rural electrification systems. Requirements dealing with protection against electric shock are based on basic rules from IEC 61140 and IEC 60364.

Decentralized Rural Electrification Systems (DRES) are designed to supply electric power for sites which are not connected to a large interconnected system, or a national grid, in order to meet basic needs.

The majority of these sites are:

- isolated dwellings,
- village houses,
- community services (public lighting, pumping, health centers, places of worship or cultural activities, administrative buildings, etc.),
- economic activities (workshops, micro-industry, etc.).

The DRE systems fall into three categories:

- process electrification systems (for example for pumping),
- individual electrification systems (IES) for single users,
- collective electrification systems (CES) for multiple users.

Process or individual electrification systems exclusively consist of two subsystems:

- an electric energy generation subsystem,
- the user's electrical installation.

Collective electrification systems, however, consist of three subsystems:

- an electric energy generation subsystem,
- a distribution subsystem, also called microgrid,
- user's electrical installations including interface equipment between the installations and the microgrid.

The general requirements specified in this part of IEC 62257 should be applied to all the identified categories of DRES. Application to each subsystem of a DRES is dealt within a specific subpart of IEC TS 62257-9.

### 2 Normative references

The following documents, in whole or in part, are normatively referenced in this document and are indispensable for its application. For dated references, only the edition cited applies. For

undated references, the latest edition of the referenced document (including any amendments) applies.

IEC 60364-4-41, *Low-voltage electrical installations – Part 4-41: Protection for safety – Protection against electric shock*

IEC 60364-4-43, *Low-voltage electrical installations – Part 4-43: Protection for safety – Protection against overcurrent*

IEC 60364-4-44:2007, *Low-voltage electrical installations – Part 4-44: Protection for safety – Protection against voltage disturbances and electromagnetic disturbances*  
IEC 60364-4-44:2007/AMD1:2015

IEC 60364-5-52:2009, *Low-voltage electrical installations – Part 5-52: Selection and erection of electrical equipment – Wiring systems*

IEC 60364-5-53:2001, *Electrical installations of buildings – Part 5-53: Selection and erection of electrical equipment – Isolation, switching and control*  
IEC 60364-5-53:2001/AMD1:2002  
IEC 60364-5-53:2001/AMD2:2015

IEC 60364-5-54, *Low-voltage electrical installations – Part 5-54: Selection and erection of electrical equipment – Earthing arrangements and protective conductors*

IEC 60364-7-712, *Electrical installations of buildings – Part 7-712: Requirements for special installations or locations – Solar photovoltaic (PV) power supply systems*

IEC 62305-2:2010, *Protection against lightning – Part 2: Risk management*

IEC 62305-3:2010, *Protection against lightning – Part 3: Physical damage to structures and life hazard*

IEC 61140:2015, *Protection against electric shock – Common aspects for installation and equipment*

IEC TS 62257-1, *Recommendations for renewable energy and hybrid systems for rural electrification – Part 1: General introduction to IEC 62257 series and rural electrification*

IEC TS 62257-2, *Recommendations for renewable energy and hybrid systems for rural electrification – Part 2: From requirements to a range of electrification systems*

IEC TS 62257-3, *Recommendations for renewable energy and hybrid systems for rural electrification – Part 3: Project development and management*

IEC TS 62257-4, *Recommendations for renewable energy and hybrid systems for rural electrification – Part 4: System selection and design*

IEC TS 62257-6, *Recommendations for renewable energy and hybrid systems for rural electrification – Part 6: Acceptance, operation, maintenance and replacement*

### **3 Terms and definitions**

For the purposes of this document, the following terms and definitions apply.

**3.1**  
**decentralized rural electrification system**  
**DRES**

any electrical power system that is stand alone and not connected to the grid

**3.2**  
**Renewable Energy**  
**RE**

energy from a source that is not depleted when used

**3.3**  
**mini-grid**

subsystem of a DRES intended for power distribution

**3.4**  
**mini-powerplant**

energy source of a DRES

**3.5**  
**Surge Protection Device**  
**SPD**

device intended to limit transient overvoltages and divert surge currents; contains at least one non-linear component. An appliance/device designed to protect electrical devices from voltage spikes.

**3.6**  
**protection against electric shock**

provision of measures reducing the risk of electric shock

**3.7**  
**basic protection**

protection against electric shock under normal conditions

**3.8**  
**fault protection**

protection against electric shock under single-fault conditions

**3.9**  
**hazardous-live-part**

live part which, under certain conditions, can give a harmful electric shock

**3.10**  
**lightning protection system**  
**LPS**

complete system used to reduce physical damage due to lightning flashes to a structure

**3.11**  
**external lightning protection system**

part of the LPS consisting of an air-termination system, a down-conductor system and an earth-termination system

**3.12**  
**earthing arrangement**  
**grounding arrangement, US**

all the electric connections and devices involved in the earthing of a system, an installation and equipment

### 3.13 equipotential bonding system EBS

interconnection of conductive parts providing equipotential bonding between those parts

Note 1 to entry: If an equipotential bonding system is earthed, it forms part of an earthing arrangement.

## 4 Classification of decentralised rural electrification systems

DRESs are classified into six different types. See Table 1.

**Table 1 – Typology of decentralized electrification systems**

Type of generator		Classification of associated systems	
		Individual	Collective
REN only, hybrid or not	no storage	T <sub>1</sub> .I	T <sub>1</sub> .C
REN only, hybrid or not	storage	T <sub>2</sub> .I	T <sub>2</sub> .C
REN, hybrid or not plus Genset	no storage	T <sub>3</sub> .I	T <sub>3</sub> .C
REN, hybrid or not plus Genset	storage	T <sub>4</sub> .I	T <sub>4</sub> .C
Genset only	no storage	T <sub>5</sub> .I	T <sub>5</sub> .C
Genset only	storage	T <sub>6</sub> .I	T <sub>6</sub> .C

Notation principle: T<sub>i</sub>.I = individual system, type i; T<sub>j</sub>.C = collective system, type j.  
Storage: storage of energy produced by one of the generator of the system and which can be reconverted.

Architecture and characteristics of the different electrification system types are developed in Clause 6 of IEC TS 62257-2:2015.

## 5 Protection against electric shock

### 5.1 General

Basic rules for protection against electric shock are given in IEC 61140 and IEC 60364-4-41. Information is also available in Annex A.

### 5.2 Requirements on the d.c. side of a DRES

The principles for the design and erection of a d.c. electrical circuit are similar to those for an a.c. circuit. The main differences concern short-circuit current calculation and the selection of the protective devices.

Protection by extra-low voltage (SELV and PELV systems) or protection by double or reinforced insulation should preferably be adopted on the d.c. side of DRES.

Simple separation, at least, should be provided between the a.c. side and the d.c. side unless the inverter is not able, by construction, to feed d.c. fault current into the a.c. installation.

Earthing of one of the live conductors of the d.c. side is permitted, if there is at least simple separation between the d.c. side and the a.c. side.

### 5.3 Requirements on the a.c. side of a DRES

#### 5.3.1 General

Protection by use of automatic disconnection of supply should preferably be adopted on the a.c. side of a DRES. For each circuit, maximum disconnecting times given in IEC 60364-4-41 should apply.

TN-S or TN-C-S system should preferably be used for decentralized rural electrification system, TT system is acceptable. IT system is normally not used for DRES and has hence not been dealt with in this specification.

A residual current protective device, with a rated residual operating current not exceeding 30 mA, should be provided as additional protection for each installation.

#### 5.3.2 TT system

Basic protection is provided by basic insulation of live parts or by barriers or enclosures. Fault protection is provided by residual current devices regarding the resistance value of the earth electrode to which the PE conductor is connected. The fault current should be high enough to activate the differential current device. The rated operating residual current  $I_{\Delta n}$  of the device should fulfil the formula:

Formula: Rated operating residual current

$$I_{\Delta n} \leq \frac{U_L}{R_A} \quad \text{with} \quad U_L = 50 \text{ V}$$

where  $U_L$  is the conventional maximum voltage and  $R_A$  is the earthing resistance.

This formula results in the values shown in Table 2.

**Table 2 – Rated operating residual current of the protective device depending on the value of the earthing resistance**

$R_A$ $\Omega$	$I_{\Delta n}$ A
$R_A \leq 50$	1
$50 < R_A \leq 100$	0,5
$100 < R_A \leq 167$	0,3
$167 < R_A \leq 300$	0,1
$300 < R_A \leq 500$	0,03

#### 5.3.3 TN system

Basic protection is provided by basic insulation of live parts or by barriers or enclosures. Fault protection is provided by devices protecting against over-currents.

Additional information is given in Annexes A and B.

## 6 Protection against overcurrent

### 6.1 General

Protective devices should be provided to break any over-current flowing in the circuit conductors before such a current could cause a danger due to thermal and mechanical effects or a temperature rise detrimental to insulation, joints, termination (see IEC 60364-4-43).

### 6.2 Protection against overload currents

The operating characteristics of a device protecting a cable against overload current should satisfy the two following conditions:

$$I_B \leq I_n \leq I_Z$$

$$I_2 \leq 1,45 \times I_Z$$

where

$I_B$  is the design current of the circuit;

$I_Z$  is the continuous current-carrying capacity of the cable;

$I_n$  is the rated current of the protective device;

$I_2$  is the current ensuring effective operation in the conventional time of the protective device.

### 6.3 Protection against short-circuits

For cables and isolated conductors, each short-circuit protective device should meet both of the following conditions:

- The breaking capacity should not be less than the prospective short-circuit current at the place of its installation, except where another protective device having the necessary breaking capacity and coordinated characteristics is installed upstream.
- All current caused by a short-circuit occurring at any point of the circuit should be interrupted in a time not exceeding that which brings the conductors to the admissible limit temperature. For short-circuits of duration up to 5 s, the time  $t$ , in which a given short-circuit current will raise the conductors from the highest admissible temperature in normal duty to the limit temperature can, as an approximation, be calculated from the formula:

$$\sqrt{t} = k \times S/I$$

where

$t$  is the duration in s;

$S$  is the cross-sectional area, in square millimetres;

$I$  is the effective short-circuit current, in amperes, expressed as r.m.s. value;

$k$  is a factor taking account of the resistivity, temperature coefficient and heat capacity of the conductor material, and the appropriate initial and final temperatures.

## 7 Protection against risk of fire

Where there is a risk of personal injury or property damage due to fire caused by an earth fault in the system, a residual current protective device should be provided at least at the origin of the user's installation. Its rated operating residual current should be  $\leq 300$  mA. Such a device should switch all live conductors.

## 8 Protection against effects of lightning

### 8.1 Principle

Information about the effects of lightning on electrical supply systems is given in Annex D.

Decision for lightning protective provision (lightning rod, surge protective devices, etc.) should be based on risk assessment, taking account of the lightning frequency statistics, the characteristics and position of the structures, the length of the overhead lines, if any, the cost and the requested availability of the equipment.

### 8.2 Examples

Examples of risk assessment methods appropriate for lightning protection can be found in IEC 60364-4-44:2007, Clause 443 and IEC 62305-2:2010, Provisions for lightning protection of DRES.

### 8.3 Protection against overvoltage

Where protection against overvoltage (for example due to indirect lightning) is required, an SPD(s) should be installed both at the distribution board of the micro-power plant, and at the origin of the user's installations or associated with each socket-outlet.

Installation of SPD should comply with IEC 60364-5-53:2001, Clause 534.

To minimize voltages induced by lightning, the area of all wiring loops should be as small as possible.

### 8.4 Protection against direct lightning

Where protection against direct lightning is required, the following provisions apply:

- In case of wind powered generation, the lightning rod should be installed at the summit of the mast.
- Where PV generation coexists with wind-powered generation, protection against direct lightning is generally achieved by placing the panels inside the pick-up zone of the wind-powered generator mast.
- Where PV generation is alone, the panels can be protected by installing a protective wire above the PV panel or lightning rod/s with an appropriate pick-up area.
- Protection should be completed by the installation of SPDs between conductors and between conductors and earth, with appropriate characteristics (see IEC 60364-5-53:2001, Clause 534).

## 9 Determination of the pick up area of a rod or wire (see IEC 62305-3:2010)

### 9.1 General

All equipment should be selected according to the rules of IEC 60364-5-53.

### 9.2 Operational conditions and external influences

Every item of equipment should be selected and erected in compliance with the appropriate standards.

Equipment should be suitable for the nominal voltage (r.m.s. value for a.c.) of the circuit concerned and for the overvoltages which could occur.



Equipment should be selected for the design current (r.m.s. value for a.c.) which it has to carry in normal service.

Equipment on the d.c. side should be suitable for direct voltage and direct current.

Equipment should also be capable of carrying the currents likely to flow in abnormal conditions for such periods of time as are determined by the characteristics of the protective devices.

If frequency has an influence on the characteristics of equipment, the rated frequency of the equipment should correspond to the frequency and frequency variations which could occur in the circuit concerned.

The electrical equipment should withstand the expected external influences such as wind, ice formation, temperature and solar radiation, etc. If a piece of equipment does not have, by construction, the necessary qualities corresponding to the location in which it is installed, appropriate additional protection should be provided, forming part of the installation.

Electrical equipment should be selected and erected so that it does not produce, in normal service, any interference with the other equipment in the system. The causes of interference include:

- power factor;
- inrush current;
- phase unbalance (three-phase systems);
- harmonics.

### 9.3 Wiring system

The minimum cross-sectional area of protective conductors should be determined according IEC 60364-5-54.

The minimum cross sectional area of conductors should be determined according to:

- The current-carrying capacity of conductors taking account of external influences and of the methods of installation. See tables in IEC 60364-5-52.
- The acceptable voltage drop in conductors of the user's installations should be determined according IEC 60364-5-54. Voltage values should comply with the following limits at the terminals of any user's electrical equipment:

For a.c. voltage,

$$0,90 \times 230 \text{ V} < U_{\text{a.c.}} < 1,10 \times 230 \text{ V}$$

For d.c. voltage,

$$0,85 \times 12 \text{ V} < U_{\text{d.c.}} < 1,20 \times 12 \text{ V or}$$

$$0,85 \times 24 \text{ V} < U_{\text{d.c.}} < 1,20 \times 24 \text{ V}$$

### 9.4 Isolation and switching

#### 9.4.1 Isolation

The purpose of isolation is to separate a circuit or equipment unit from the rest of the system in order to guarantee the safety of persons who may have to work on, to maintain or repair it.

Every circuit should be capable of being isolated.

In TN-C-S systems, the PEN conductor should not be interrupted (broken, switched or disconnected).

In TN-S systems, the neutral conductor needs not be interrupted.

Suitable means (padlocking, location within lockable enclosure, etc.) should be provided to prevent any equipment from being unintentionally energised.

The isolating distance between open contacts should be visible or clearly and reliably indicated.

**9.4.2 Over-current protective devices**

**9.4.2.1 General**

Fuses (gPV type) or circuit-breakers with appropriate range of instantaneous tripping should be used.

The range of instantaneous tripping for a circuit-breaker should be selected according to the prospective short-circuit current.

Overcurrent protective devices should be preferably of a type ensuring protection against both overload and short-circuit currents and capable of acting as isolating switch in the open position.

Special attention should be paid to over-current protective devices installed in series, to ensure that an appropriate coordination is achieved. Selectivity between protective devices in series should preferably be total.

**9.4.2.2 AC over-current protective devices**

The number of protected poles depends on the neutral earthing distribution system and on the cross-sectional area the neutral conductor, in accordance with Table 3.

NOTE A protected pole is a pole provided with an over-current release.

**Table 3 – Number of protected poles with regard to the characteristics of the distribution system**

Distribution system	Conductors	Cross-sectional area of the neutral, PEN or PEL conductor	Protected poles	Conditions
TT or TN-S	3 L		3 L	
	3 L + N	$S_N = S_L$	3 L or 3 L + N	
	L + N	$S_N = S_L$	L or L + N	
	3 L + N	$S_N < S_L$	3 L	1 + 2 + 3 + 4
	3 L + N	$S_N < S_L$	3 L + N	1 + 2 + 3
TN-C-S	3 L + PEN	$S_{PEN} = S_L$	3 L	
	3 L + PEN	$S_{PEN} < S_L$	3 L	1 + 2 + 3 + 4
	L + PEL	$S_{PEL} = S_L$	L	

Conditions:

- 1: The cross-sectional area of the conductors is >16 mm<sup>2</sup> Cu or >25 mm<sup>2</sup> Al.
- 2: The power consumed between phases and neutral is <10 % of the total power transmitted by the mains.
- 3: The maximum current expected to flow in the neutral conductor is less than its permissible current.
- 4: The neutral conductor is protected against short-circuits by the steps taken to protect the phase conductors.

### 9.4.2.3 DC over-current protective devices

For the selection of d.c. overcurrent protective devices, it is recommended to be assisted by the manufacturer after having determined and transmitted the characteristics of the circuit (short-circuit current, rated current, time constant).

NOTE For calculation of the short-circuit current in case of a battery whose internal resistance is not known, the following formula can be used:

$$I_k = 10 \times C$$

where  $C$  is in A/h.

For calculation of the short-circuit current at the terminals of a d.c. generator, the following formula can be used:

$$I_k = 1,1 \times U_n / R_i$$

where  $R_i$  is the internal resistance of the generator.

For calculation of the short-circuit current at any point of the installation, the following formula can be used:

$$I_k = 1,1 \times U_n / R_i + 2R_L$$

where  $R_L$  is the line resistance.

And in case of the presence of a d.c. motor, the value of  $I_k$ , here above is increased by the value of  $6I_N$  of the motor.

### 9.4.3 Residual Current Devices (RCD)

Residual current devices should be so selected, and the electric circuits so subdivided that any earth leakage current which may be expected to occur during normal operation of the connected load(s) will be unlikely to cause unnecessary tripping of the device.

NOTE Residual current protective devices can operate at any value of residual current in excess of 50 % of the rated operating current.

Residual current protective devices in d.c. systems should be specially designed for detection of d.c. residual currents, and to break circuit currents under normal conditions and fault conditions.

For the systems concerned, RCDs installed upstream surge protective devices should be of type S, in order to allow service continuity.

## 9.5 Surge protective devices

The selection and erection of SPDs should comply with IEC 60364-5-53:2001, Clause 534.

The following are the leading parameters needed to select SPDs (see also Clause C.3):

UP = protection level for nominal current (for example 2,5 kV, 1,5 kV).

UC = continuous service voltage to be chosen on the basis of mains nominal voltage.

$I_{\text{nominal}}$  (8/20 wave) = nominal discharge current. Standard values: 20 kA, 10 kA, 5 kA, etc.

Use of SPDs in presence of harmonics (e.g. where non sine-wave inverters are used) is problematic. Due to harmonics, the ageing of varistors is accelerated. One solution to overcome this is to install SPDs including internal spark-gaps in series with the varistor (SiC or ZnO). New SPD technologies are to be considered as well.

## **9.6 Earthing arrangement, protective conductors and protective bonding conductors**

### **9.6.1 Earth electrodes**

#### **9.6.1.1 General**

Materials and dimensions of the earth electrodes should be selected to withstand corrosion and to have mechanical strength.

When selecting type and embedded depth of earth electrode, consideration should be given to local conditions so that soil drying and freezing will be unlikely to increase the earth resistance of the earth electrode to such a value that would impair the protective measures against electric shock.

#### **9.6.1.2 Earth electrodes for the supply system**

Examples of earth electrodes which may be used are:

- underground structural network embedded in foundations (foundation earth electrode),
- rods or pipes,
- tapes or wires,
- metal sheaths and other metal coverings of cables according to local conditions or requirements,
- plates.

Where possible, a foundation earth electrode should be preferred.

Common minimum sizes for earth electrodes of commonly used material can be found in IEC 60364-5-54.

#### **9.6.1.3 Earth termination (electrode) of a lightning protection system**

In order to disperse the lightning current into the earth without causing dangerous overvoltages, the shape and the dimensions of the earth termination system of an LPS are more important than the value of the resistance of the earth electrode (characteristic applicable for d.c. or low frequency phenomena).

The earth termination system should be composed of:

- either conductors of the same nature and same cross-section as the down-conductors (in general, 30 mm × 2 mm copper strip) laid out in the form of a large crow's foot: 3 conductors 7 m to 8 m long buried horizontally at a depth of at least 0,60 m,
- or a set of 3 vertical rods 2 m in length connected together and set out at the apexes of an equilateral triangle with sides measuring about 2 m.

The earth termination system of the LPS should be bonded to the earthing arrangement with short connexions.

#### **9.6.1.4 Application to the protection of an ENR power system**

The wind-powered generator and/or the frame of the PV panels should be earthed by a crow's foot earth electrode with the lowest possible resistance (a 10 Ω at 50 Hz is frequently adopted). This earth electrode should be bonded, with short connexions, to the earthing arrangement of the technical rooms housing the other equipment of the installation.

### **9.6.2 Protective bonding conductors**

Where protective equipotential bonding conductors are installed, they should be parallel to and in closest contact as possible with d.c. cables and a.c. cables and accessories (IEC 60364-7-712).

## **10 Verification**

See IEC TS 62257-6.

## **11 Operation and maintenance**

See IEC TS 62257-6.

## **Annex A** (informative)

### **Protection against electric shock in electrical installations**

#### **A.1 Protection against electric shock**

The fundamental rule of protection against electric shock, according to IEC 61140, is that hazardous-live-parts should not be accessible and accessible conductive parts should not be hazardous live either under normal conditions or under single fault conditions.

According to IEC 61140, protection under normal conditions is provided by basic protective provisions and protection under single fault conditions is provided by fault protective provisions. Alternatively, protection against electric shock is provided by an enhanced protective provision which provides protection under normal conditions and under single fault conditions.

Consequently, a protective measure is:

- an appropriate combination of a protective provision for basic protection and an independent protective provision for fault protection, or
- an enhanced protective provision which provides both basic protection and fault protection.

In each part of an installation, one or more protective measures should be applied. Except otherwise specified, the following protective measures are permitted:

- automatic disconnection of supply;
- double or reinforced insulation;
- electrical separation for the supply of one item of current using equipment;
- extra-low voltage.

The following protective measures:

- use of obstacles;
- placing out of reach;

should only be used under the control of skilled or instructed persons.

The following protective measures:

- non-conducting location;
- earth-free local equipotential bonding;
- electrical separation for the supply of more than one item of current using equipment;

may be applied only when the installation is under the control of skilled or instructed persons so that unauthorized changes cannot be made.

#### **A.2 Automatic disconnection of supply**

##### **A.2.1 General**

Automatic disconnection of supply is a protective measure in which:

- basic protection is provided by basic insulation of live parts or by barriers or enclosures, and
- fault protection is provided by automatic disconnection of supply.

NOTE 1 Where specified, additional protection is provided by a residual current protective device with rated residual operating current not exceeding 30 mA.

A protective device should automatically disconnect the supply to the circuit or equipment in the event of a fault between a live part and an exposed-conductive-part or a protective conductor in the circuit or equipment within the time required.

The maximum disconnection time is given in IEC 60364-4-41.

If automatic disconnection cannot be achieved in the time required as appropriate, supplementary protective equipotential bonding should be provided.

In a.c. systems, additional protection by means of a residual current protective device with rated residual operating current not exceeding 30 mA should be provided for:

- socket-outlets with a rated current not exceeding 20 A, under the supervision of ordinary persons, and
 

NOTE 2 This additional protection can be in the socket-outlets (SRCD) or the circuit supplying the socket-outlet.

NOTE 3 For example, domestic dwellings are normally under the supervision of ordinary persons.
- the final circuits for hand-held and Class I current-using equipment, with a current rating not exceeding 32 A, for use outdoors where the equipment is connected other than through a socket-outlet.

### A.2.2 In TN systems

The characteristics of protective devices and the circuit impedances should fulfil the following requirement:

$$Z_s \times I_a \leq U_o \quad (\text{A.1})$$

where

$Z_s$  is the impedance in ohms of the fault loop comprising the source, the live conductor up to the point of the fault and the protective conductor between the point of the fault and the source;

$I_a$  is the current in amps causing the automatic operation of the disconnecting device within the time required. When the protective device is a residual current protective device, this current is the rated residual operating current;

$U_o$  is the nominal a.c. or d.c. line to earth voltage, in volts.

### A.2.3 In TT systems

When a residual current device is used for fault protection, the following condition should be fulfilled:

$$R_A \times I_{\Delta n} \leq 50 \text{ V} \quad (\text{A.2})$$

where

$R_A$  is the sum of the resistance in ohms of the earth electrode and the protective conductor for the exposed conductive-parts;

$I_{\Delta n}$  is the rated residual operating current of the RCD.

When an overcurrent protective device is used for fault protection, the following condition should be fulfilled:

$$Z_s \times I_a \leq U_o \quad (\text{A.3})$$

where

$Z_s$  is the impedance in ohms of the fault loop comprising the source, the live conductor up to the point of the fault, the protective conductor of the exposed conductive parts, the earth electrode of the installation and the earth electrode of the source;

$I_a$  is the current in amps causing the automatic operation of the disconnecting device within the time required;

$U_o$  is the nominal a.c. r.m.s. or ripple-free d.c. voltage, in volts to earth.

### A.3 Double or reinforced insulation

Double or reinforced insulation is a protective measure in which:

- basic protection is provided by basic insulation, and fault protection is provided by supplementary insulation, or
- basic and fault protection is provided by reinforced insulation between live parts and accessible parts.

NOTE This protective measure is intended to prevent the appearance of dangerous voltage on the accessible parts of electrical equipment through a fault in the basic insulation.

### A.4 Extra-low-voltage (SELV and PELV)

Protection by extra-low-voltage is a protective measure which consists of two different extra-low-voltage systems:

- SELV
- PELV

in which protection is provided by:

- limitation of voltage in the SELV or PELV system to a.c. voltage of 50  $V_{a.c.}$  or d.c. voltage of 120  $V_{d.c.}$ ,
- protective separation of the SELV or PELV system from all circuits other than SELV and PELV circuits, and basic insulation between the SELV or PELV system and other SELV or PELV systems.

For SELV systems only, basic insulation is provided between the SELV system and earth.

### A.5 Electrical separation

Electrical separation is a protective measure in which:

- basic protection is provided by basic insulation of live parts or by barriers and enclosures,



- fault protection is provided by simple separation of the separated circuit from other circuits.

This protective measure should be limited to the supply of one item of current using equipment supplied from one unearthed source with simple separation.

## **A.6 Additional protection**

The use of residual current protective devices, with a rated operating residual current not exceeding 30 mA, is recognized in a.c. systems as additional protection in the event of failure of other basic protective provisions or carelessness by users.

## Annex B (informative)

### Types of LV distribution systems earthing

#### B.1 Terms and definitions

For the purposes of this Annex, the following terms and definitions apply.

##### B.1.1

##### **current-carrying conductor**

conductor which carries the electric current under normal conditions

Note 1 to entry: The line conductor (L), the neutral conductor (N), the mid-point conductor (M), the PEN conductor, the PEM conductor and the PEL conductor are the current-carrying conductors. The protective conductor (PE) is not the current-carrying conductor.

##### B.1.2

##### **distribution network**

low-voltage electrical network consisting of the power source and a distribution line (overhead line or underground cable) and intended for supplying the electric power to electrical installations of buildings and other low-voltage electrical installations

##### B.1.3

##### **distribution system**

low-voltage electrical system consisting of a distribution network and an electrical installation

Note 1 to entry: The distribution system usually includes an electrical installation of building which is connected to the low-voltage distribution network consisting of a step-down transformer substation and an overhead line or an underground cable (see Figure B.1).

Note 2 to entry: The smallest distribution system includes a power source and one item of a current-using equipment (see Figure B.2).

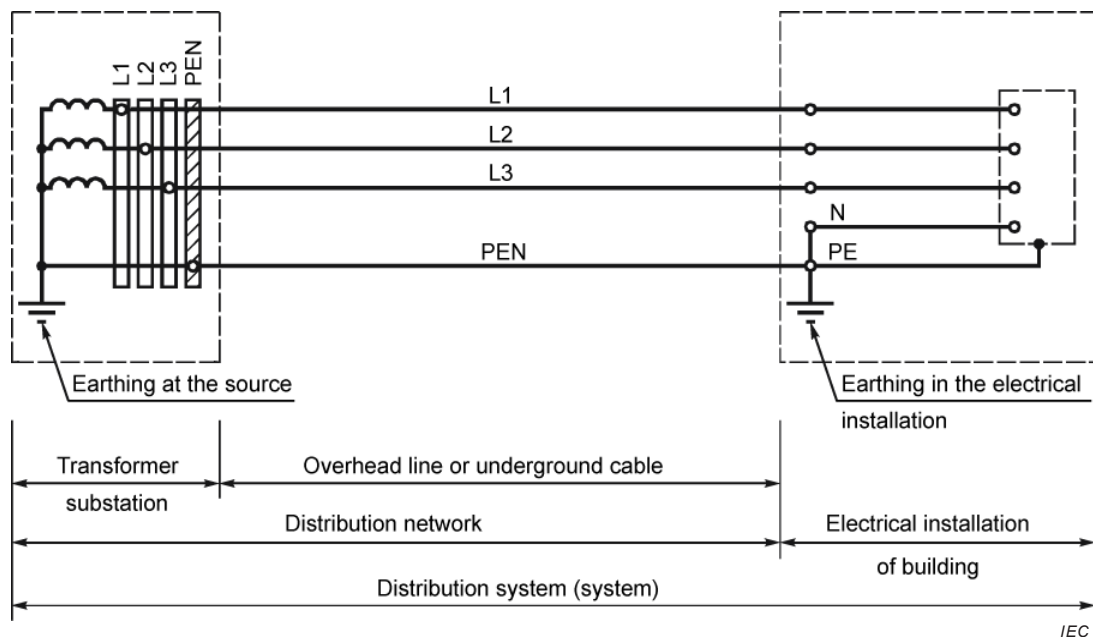

**Figure B.1 – General outline of the distribution system**

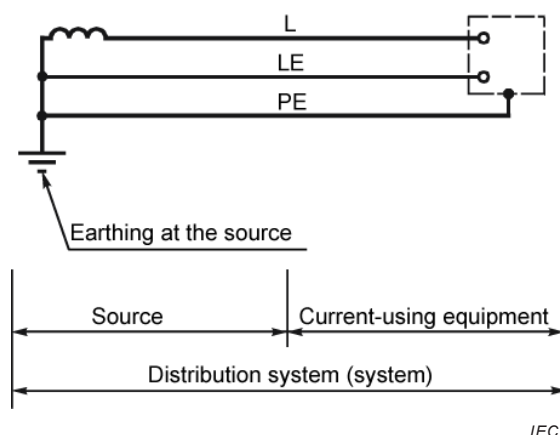

**Figure B.2 – Distribution system of the smallest type**

#### **B.1.4**

##### **earthed line conductor** (identification: LE)

line conductor which has an electrical connection with a local earth

#### **B.1.5**

##### **electrical installation of building**

assembly of associated electric equipment located in a building and having co-ordinated characteristics to fulfil specific purposes

[SOURCE: IEC 60050-826:2004, 826-01-01, modified: addition of "of building"]

#### **B.1.6**

##### **type of system earthing**

integrated characteristic of the distribution system, which assigns availability or absence of earthing of live parts of a power source, availability of earthing of exposed-conductive-parts of an electrical installation or an electrical equipment, availability and performance of electrical connection between earthed live parts of the power source and exposed-conductive-parts

Note 1 to entry: The characteristic «type of system earthing» determines special requirements to all elements of the distribution system. For components of the distribution network this characteristic determines following requirements:

- for the power source – presence or absence of earthing of its live parts. If the power source has the earthed live part the additional earthing of conductors connected electrically with the earthed live part of the power source may be provided in the distribution network. If the power source has live parts isolated from the earth the distribution network conductors, as a rule, should be isolated from the earth or, as an exception, some conductor can be earthed through an impedance;
- for the distribution line – requirements to the arrangement of the protective, neutral, mid-point and earthed line conductors.

For the electrical installations or the electrical equipment this characteristic determines requirements to earthing of the exposed-conductive-parts, and to presence or absence of an electrical connection of the exposed-conductive-parts with the earthed live part of the power source.

## **B.2 Types of system earthing used in DRES (Figures are from IEC 60364-1:2005)**

### **B.2.1 General**

The following types of system earthing for a.c. and d.c. electrical systems are taken into account in IEC 60364-1:2005.

NOTE 1 Figures B.3 to B.7, B.9 to B.12 show examples of commonly used three-phase systems. Figure B.8 shows an example of single-phase system. Figures B.13 to B.16 show examples of commonly used d.c. systems.

NOTE 2 The dotted lines indicate the parts of the system that are not covered by the scope of the standard, whereas the solid lines indicate the part that is covered by the standard.

NOTE 3 For private systems, the source and/or the distribution system may be considered as part of the installation within the meaning of this standard. For this case, the figures may be completely shown in solid lines.

The letter codes used for designations of the types of system earthing have the following meanings.

**The first letter** determines presence or absence of earthing of live parts of the power source:

- **T** – one live part of the power source is earthed.  
Additional earthing PEN, PEM, PEL conductors and protective conductor (PE) in the distribution network (if any) may be provided.
- **I** – all live parts of the power source are isolated from the earth or one live part is earthed through a high impedance.  
Conductors of the distribution network (if any), as a rule, should be isolated from the earth.

**The second letter** specifies the earthing of exposed-conductive-parts of the electrical installation or electrical connection presence between the exposed-conductive-parts and the earthed live part of the power source:

- **T** – the exposed-conductive-parts are earthed irrespective of presence or absence of the earthing of any live part of the power source;
- **N** – the exposed-conductive-parts have direct connection with the earthed live part of the power source executed by PEN, PEM, PEL conductors or protective conductors (PE).
- **Subsequent after N letters** specify how an electrical connection between the earthed live part of the power source and the exposed-conductive-parts of the electrical installation is performed in the distribution system, and also assign features of the arrangement of conductors which carry out the functions of protective conductor (PE) and the neutral (N), mid-point (M) or earthed line (LE) conductor in the distribution system:
- **C** – the specified connection is provided throughout the distribution system by means of PEN, PEM or PEL conductors. Functions of the protective conductor and the neutral, mid-point or earthed line conductor are provided throughout distribution system by means of the single conductor accordingly – PEN, PEM or PEL conductor;
- **S** – the specified connection is provided throughout the distribution system by means of the protective conductors (PE). Functions of the protective conductor and the neutral, mid-point or earthed line conductor are provided throughout distribution system by means separate conductors – the protective conductor and the neutral, mid-point or earthed line conductor;
- **C-S** – the specified connection is provided in a head part of the distribution system (from the power source) by means of PEN, PEM or PEL conductors, and in other parts of the distribution system – by means of protective conductors (PE). In the head part of the distribution system the functions of the protective conductor and the neutral, mid-point or earthed line conductor are provided by means of PEN, PEM or PEL conductor, and in other parts of the distribution system are provided by means of separate conductors – the protective conductor and the neutral, mid-point or earthed line conductor.

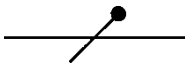
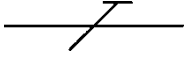
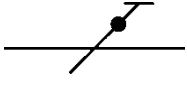
Explanation of symbols for Figures according to IEC 60617	
 IEC 60617-S00446	Neutral conductor (N); mid-point conductor (M)
 IEC 60617-S00447	Protective conductor (PE)
 IEC 60617-S00448	Combined protective earthing and a neutral conductor (PEN); combined protective earthing and a mid-point conductor (PEM)

## B.2.2 AC TN systems

### B.2.2.1 Single-source distribution systems

TN power systems have one live part directly earthed at the power source. The exposed-conductive-parts of the electrical installation are connected to that live part by protective conductors. Three types of TN systems are considered according to the arrangement of the neutral or earthed line conductor and the protective conductor, as follows:

- **TN-S system** in which, throughout the distribution system, a separate protective conductor is used (see Figures B.3, B.4 and B.5).

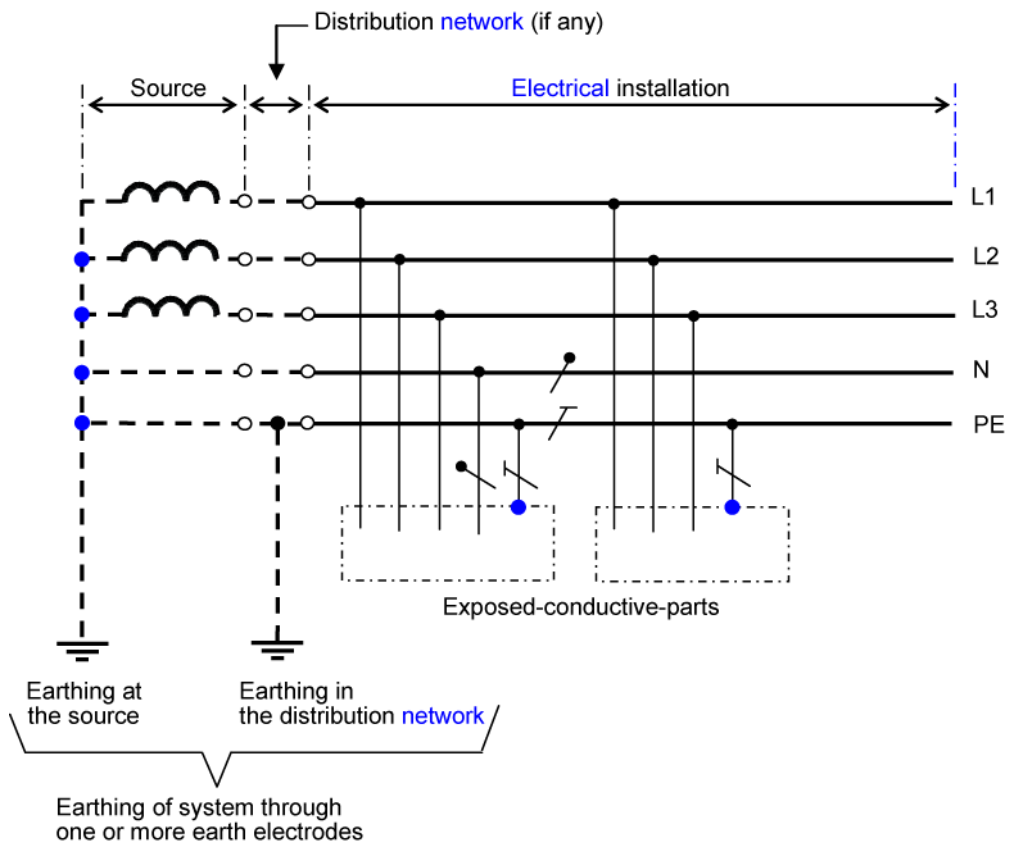

IEC

NOTE Additional earthing of the protective conductors PE in the distribution network and in the electrical installation may be provided.

**Figure B.3 – TN-S system 3-phase, 4-wire with separate neutral conductor and protective conductor throughout the distribution system**

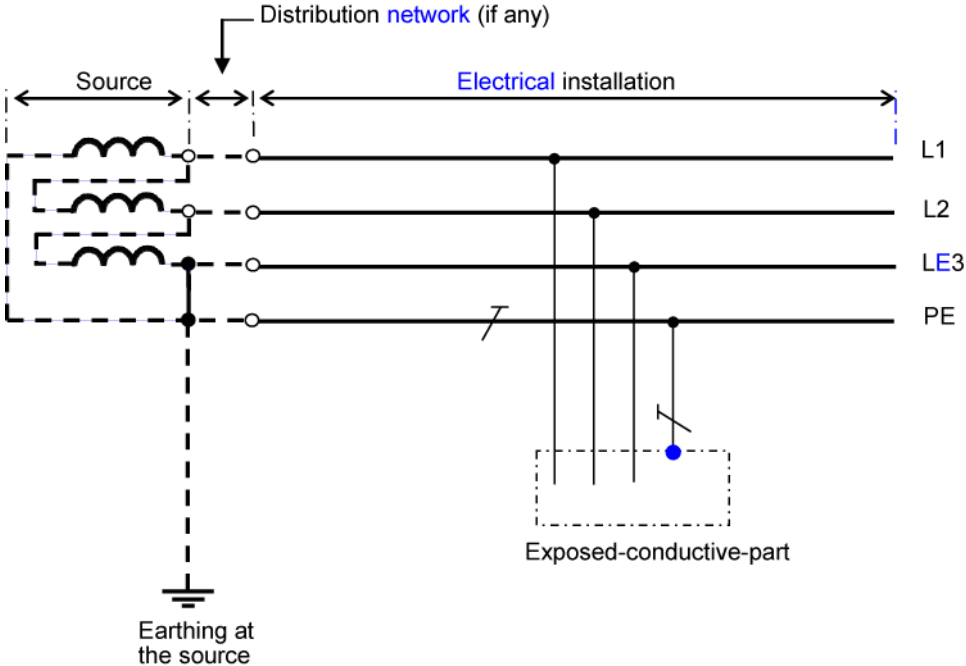

IEC

NOTE Additional earthing of the protective conductors PE in the distribution network and in the electrical installation may be provided.

**Figure B.4 – TN-S system 3-phase, 3-wire with separate earthed line conductor and protective conductor throughout the distribution system**

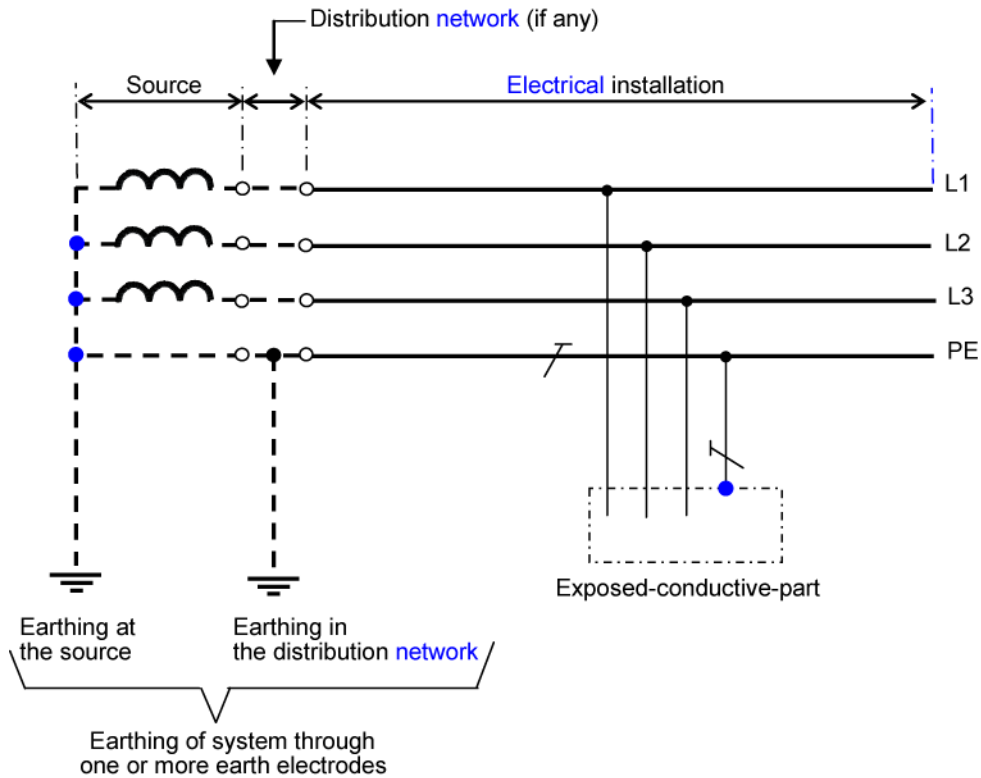

IEC

NOTE Additional earthing of the protective conductors PE in the distribution network and in the electrical installation may be provided.

**Figure B.5 – TN-S system 3-phase, 3-wire with protective conductor and no distributed neutral conductor throughout the distribution system**

- **TN-C-S system** in which a single conductor which is carrying out the neutral or earthed line conductor and protective conductor functions is used in a part of the distribution system (see Figures B.6, B.7 and B.8).

The PEN and PEL conductors are not allowed in the electrical installations of residential premises, public premises, commercial premises, medical locations. The distribution network PEN or PEL conductor should be separated into the neutral or earthed line and protective conductors at the origin of the electrical installation (see Figures B.7 and B.8).



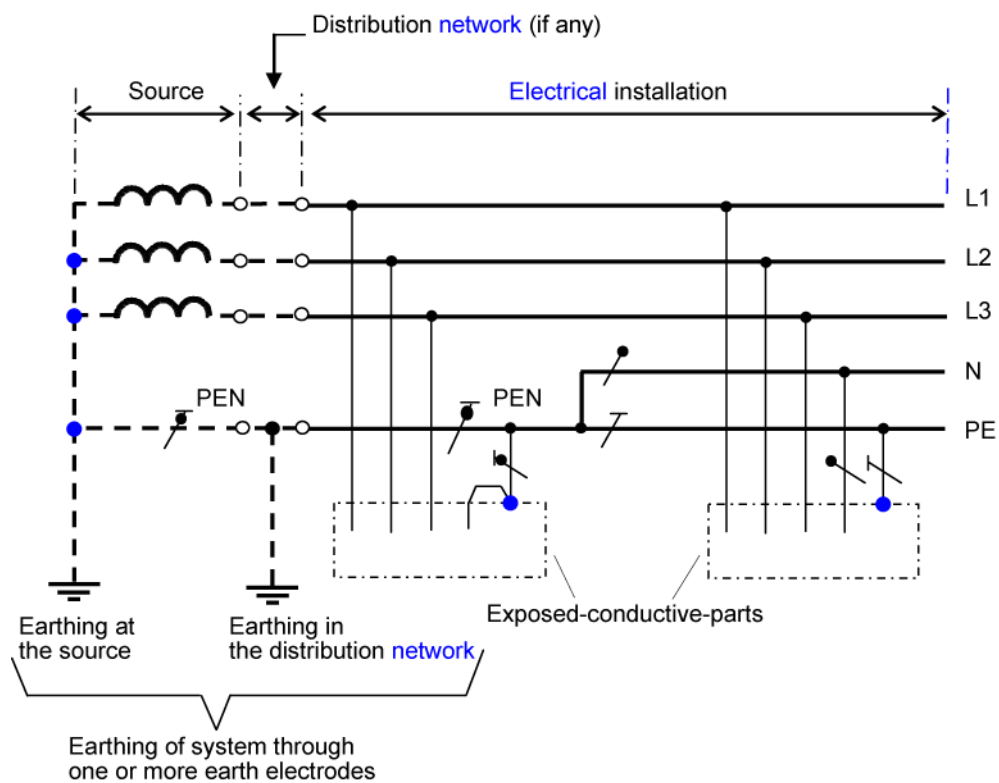

IEC

NOTE 1 Neutral and protective conductor functions combined in a single conductor in a part of the distribution system.

NOTE 2 Additional earthing of the PEN conductor or the protective conductor PE in the electrical installation may be provided.

NOTE 3 Additional earthing of the PEN conductor in the distribution network may be provided.

**Figure B.6 – TN-C-S system 3-phase, 4-wire where the PEN conductor is separated into the protective conductor PE and the neutral conductor N elsewhere in the electrical installation**

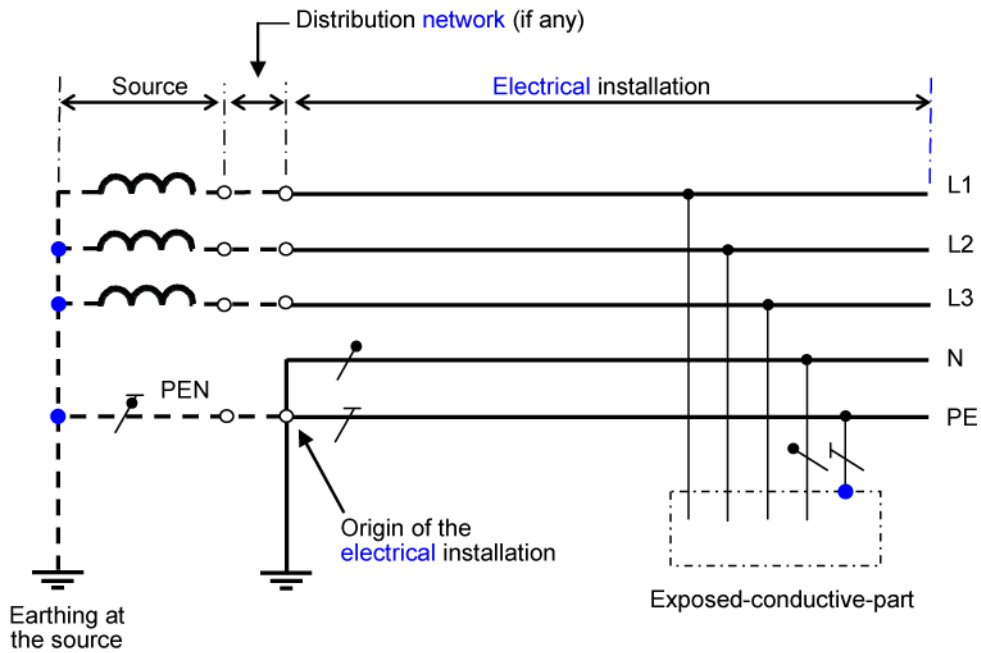

NOTE 1 Neutral and protective conductor functions combined in a single conductor in a part of the distribution system.

NOTE 2 Additional earthing of the PEN conductor in the distribution network and of the protective conductor PE in the electrical installation may be provided.

**Figure B.7 – TN-C-S system 3-phase, 4-wire where the PEN conductor is separated into the protective conductor PE and the neutral conductor N at the origin of the electrical installation**

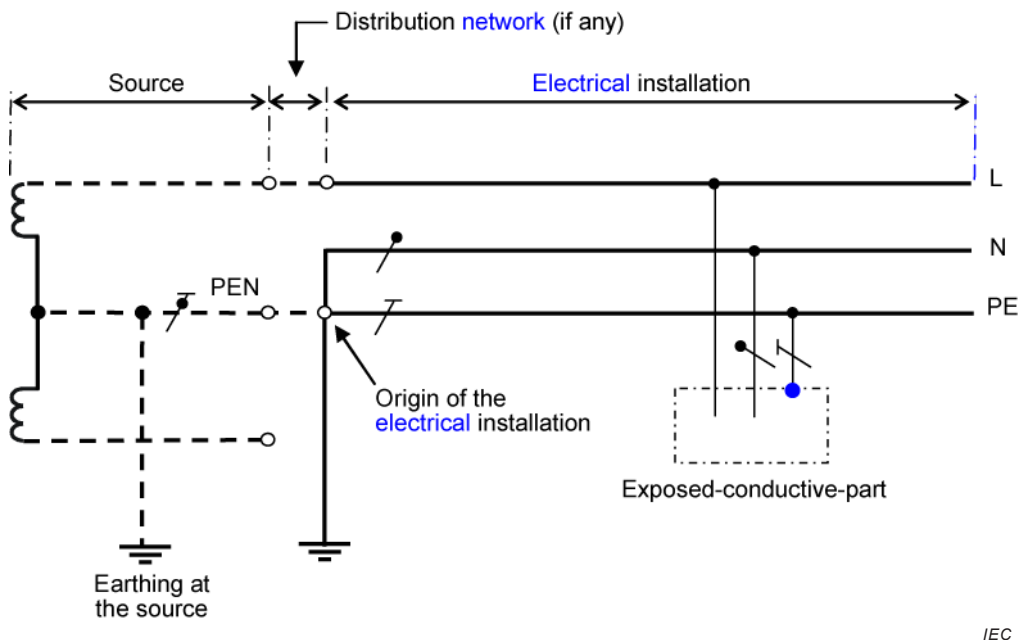

NOTE 1 Neutral and protective conductor functions combined in a single conductor in a part of the distribution system.

NOTE 2 Additional earthing of the PEN conductor in the distribution network and of the protective conductor PE in the electrical installation may be provided.

**Figure B.8 – TN-C-S system – single-phase, 2-wire where the PEN conductor is separated into the protective conductor PE and the neutral conductor N at the origin of the electrical installation**

- **TN-C system** in which a single conductor which is carrying out the neutral or earthed line conductor and protective conductor functions is used throughout the distribution system (see Figure B.9).

TN-C system is not allowed in the electrical installations of residential premises, public premises, commercial premises, medical locations.

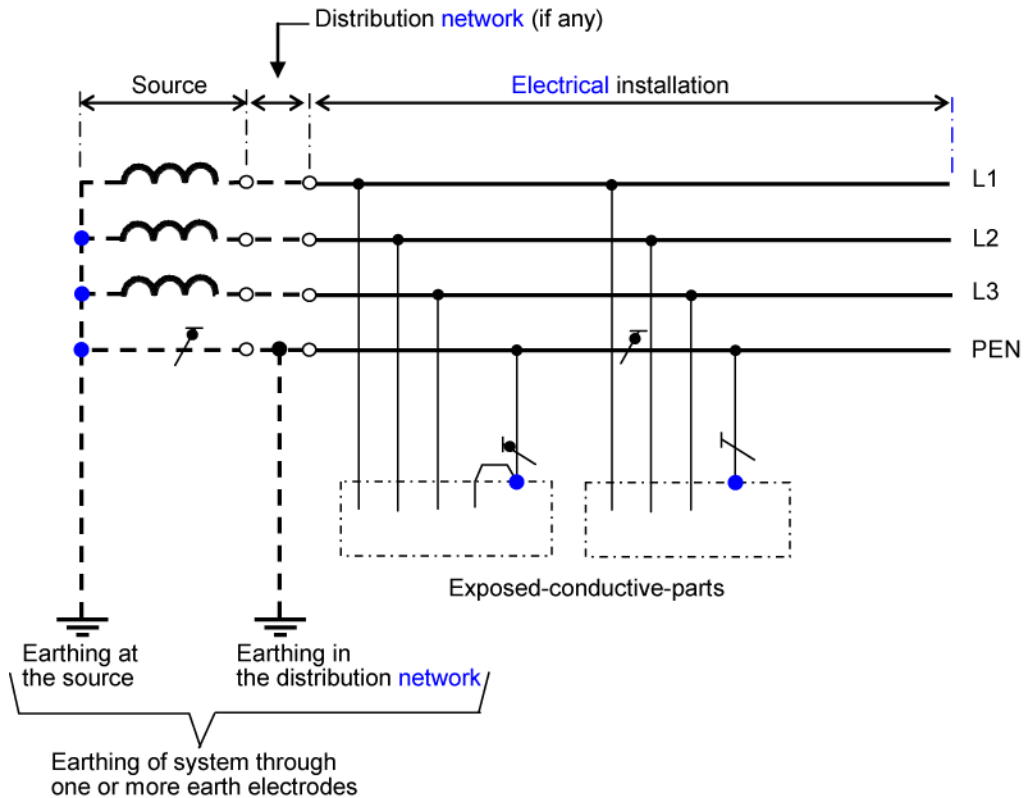

IEC

NOTE Additional earthing of the PEN conductor in the distribution network and in the electrical installation may be provided.

**Figure B.9 – TN-C system 3-phase, 4-wire with neutral and protective conductor functions combined in a single conductor throughout the distribution system**

### B.2.2.2 Multiple source distribution systems

NOTE 1 The multiple source distribution system is shown for the TN-S system with the unique aim of providing EMC. The multiple source system is not shown for IT and TT systems because these systems are generally compatible with regard to EMC.

NOTE 2 For the TT multiple source distribution system, see 444.4.6.2 of IEC 60364-4-44:2007.

In the case of an inappropriate design of an installation forming part of a TN-S system with multiple sources some of the operating current may flow through unintended paths. These currents may cause

- fire;
- corrosion;
- electromagnetic interference.

The system shown in Figure B.10 is a system where minor partial operating currents flow as currents through unintended paths. The essential design rules shown in Figure B.10 from a) to d) are given in the legend below Figure B.10.

The marking of the protective conductor PE shall be in accordance with IEC 60445.

Any extension of the system shall be taken into account with regard to the proper functioning of the protective measures.

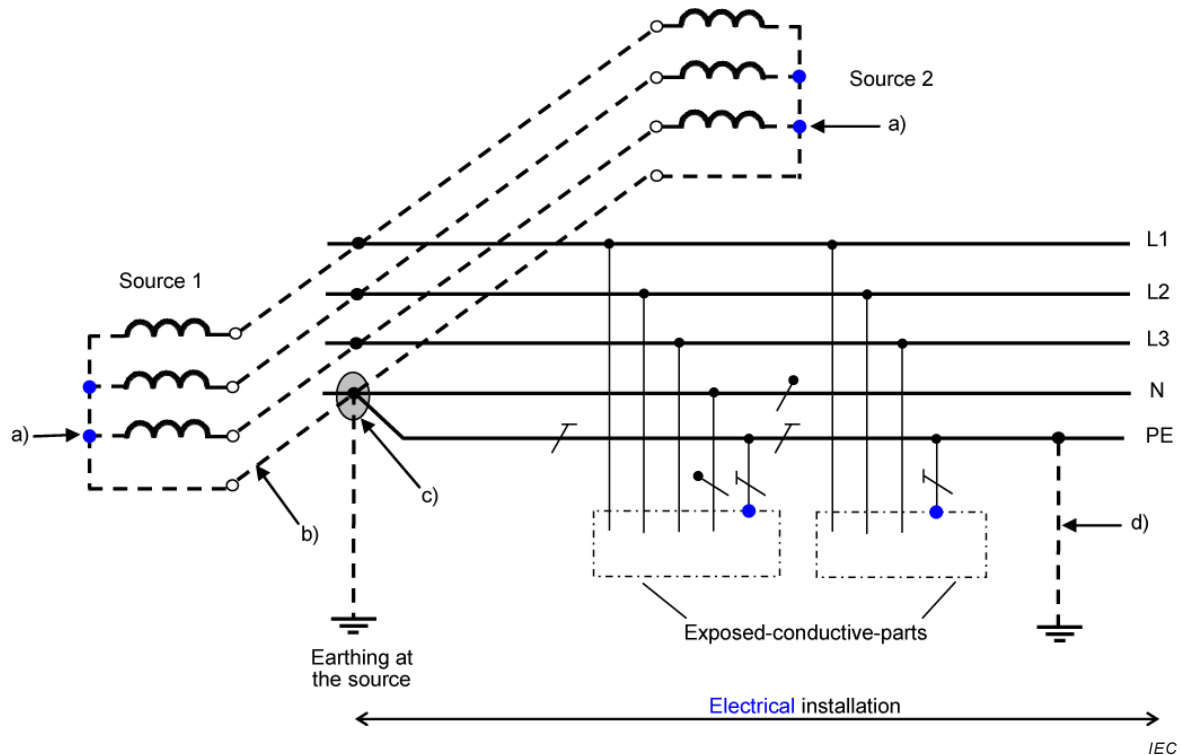

#### Key

- a) No direct connection from either the transformer or the generator neutral point to earth is permitted.
- b) The interconnection conductor between either the neutral points of the transformers or of the generators shall be insulated. The function of this conductor is like a PEN; however, it shall not be connected to current-using equipment.
- c) Only one connection between the interconnected neutral points of the sources and the protective conductor PE shall be provided. This connection shall be located inside the main switchgear assembly.
- d) Additional earthing of the protective conductor PE in the electrical installation may be provided.

**Figure B.10 – TN-S multiple source system 3-phase, 4-wire with separate protective conductor and neutral conductor to current using equipment**

#### B.2.3 AC TT systems

The TT power system has one live part directly earthed at the power source. The exposed-conductive-parts of the electrical installation are connected to earth electrodes electrically independent of the earth electrode of the power source (see Figures B.11 and B.12).

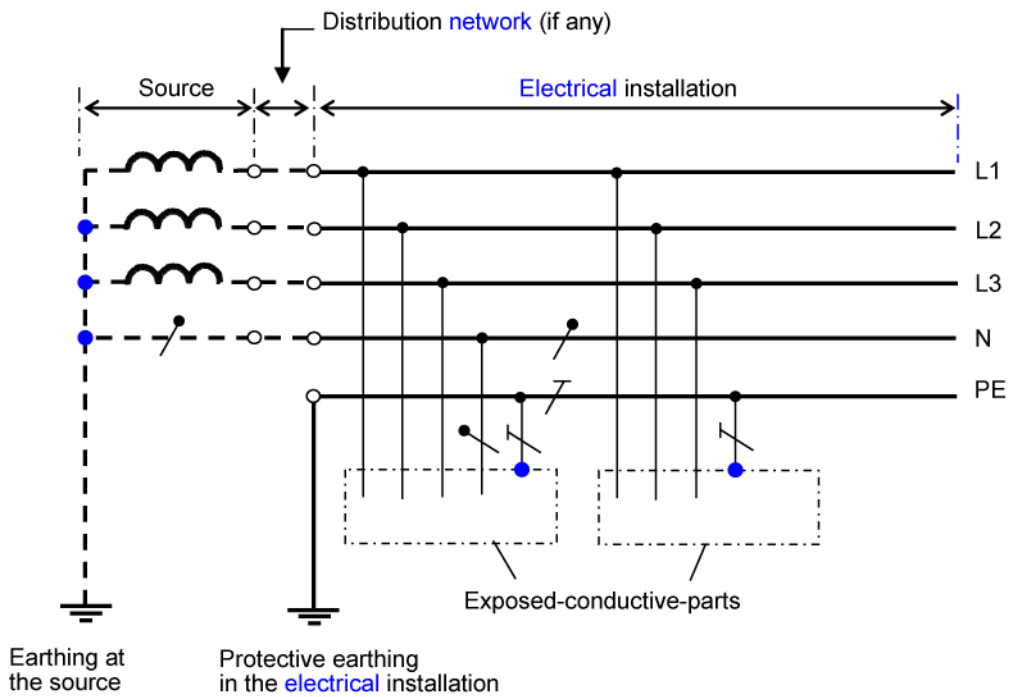

IEC

NOTE Additional earthing of the protective conductor PE in the electrical installation may be provided.

**Figure B.11 – TT system 3-phase, 4-wire with earthed protective conductor and neutral conductor throughout the distribution system**

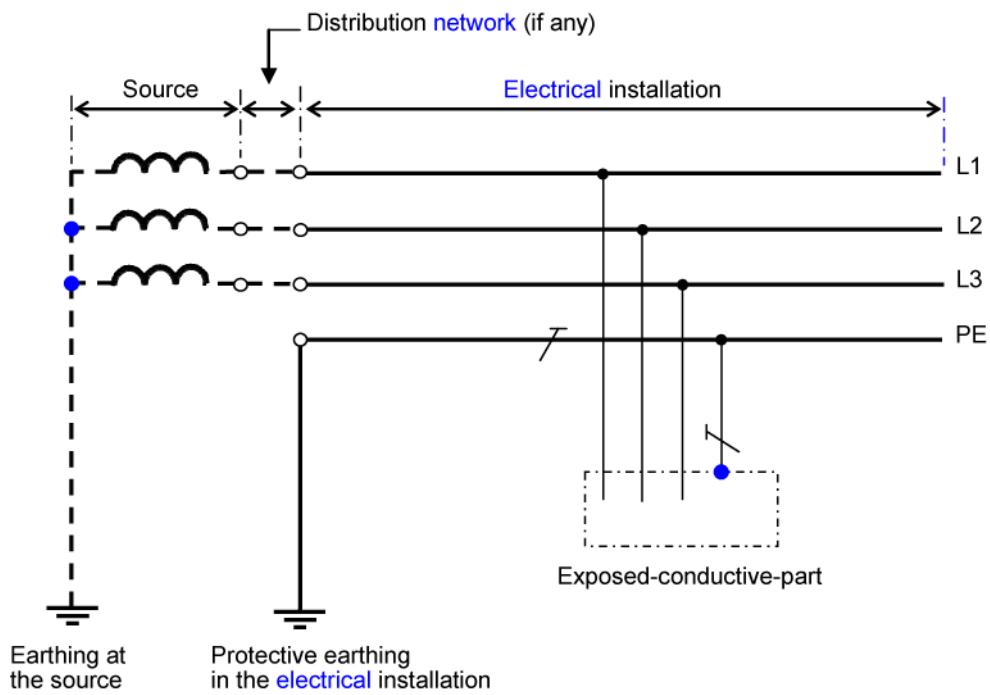

IEC

NOTE Additional earthing of the protective conductor PE in the electrical installation may be provided.

**Figure B.12 – TT system 3-phase, 3-wire with earthed protective conductor and no distributed neutral conductor throughout the distribution system**

## **B.2.4 DC distribution systems**

### **B.2.4.1 General**

Type of system earthing for direct current (d.c.) distribution systems.

Where the following Figures B.13 to B.16 show earthing of a specific pole of a two-wire d.c. system, the decision whether to earth the positive or the negative pole shall be based upon operational circumstances or other considerations, for example, avoidance of corrosion effects on line conductors and earthing arrangements.

### **B.2.4.2 TN-S-system**

The earthed line conductor LE– in the system of type a) or the earthed mid-point conductor M in the system of type b) is separated from the protective conductor throughout the electrical installation.

**Type a) – 2-wire**

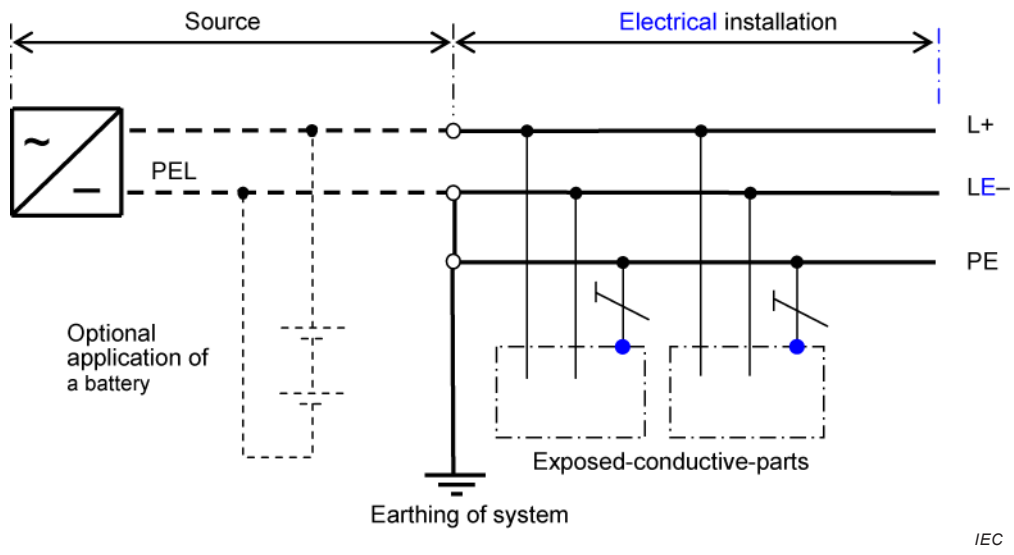

**Type b) – 3-wire**

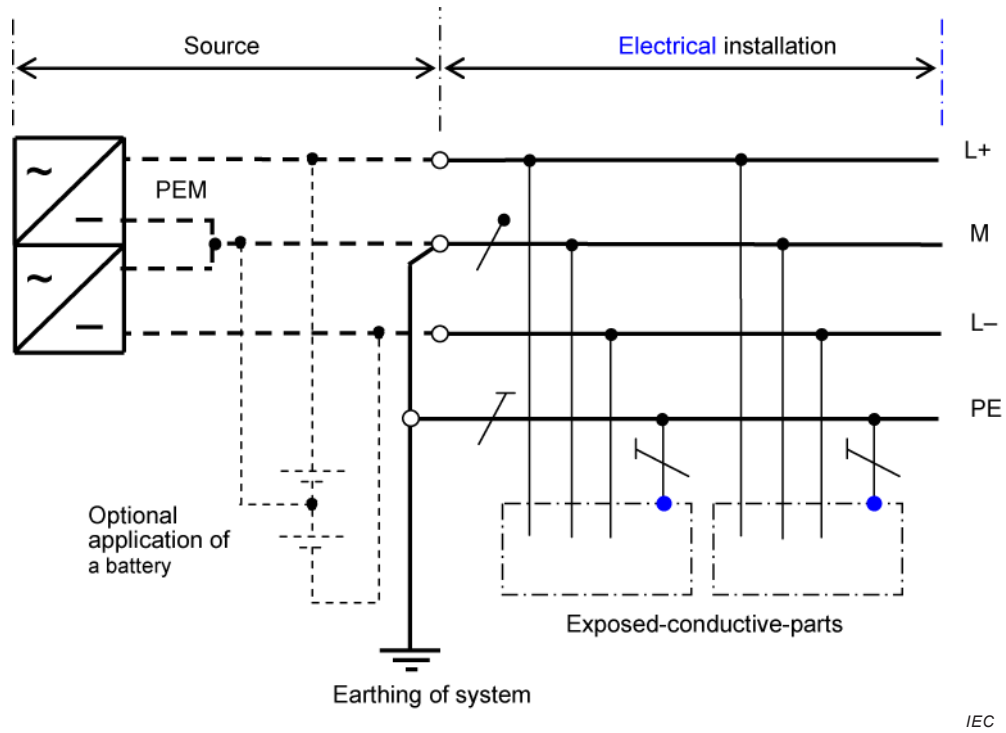

NOTE Additional earthing of the protective conductor PE in the electrical installation may be provided.

**Figure B.13 – TN-S d.c. system**

**B.2.4.3 TN-C-system**

The functions of the earthed line conductor LE- and of the protective conductor in the system of type a) are combined in one single PEL conductor throughout the electrical installation, or the earthed mid-point conductor M and the protective conductor in the system of type b) are combined in one single PEM conductor throughout the electrical installation.

TN-C system is not allowed in electrical installations of residential premises, public premises, commercial premises, medical locations or their parts.

**Type a) – 2-wire**

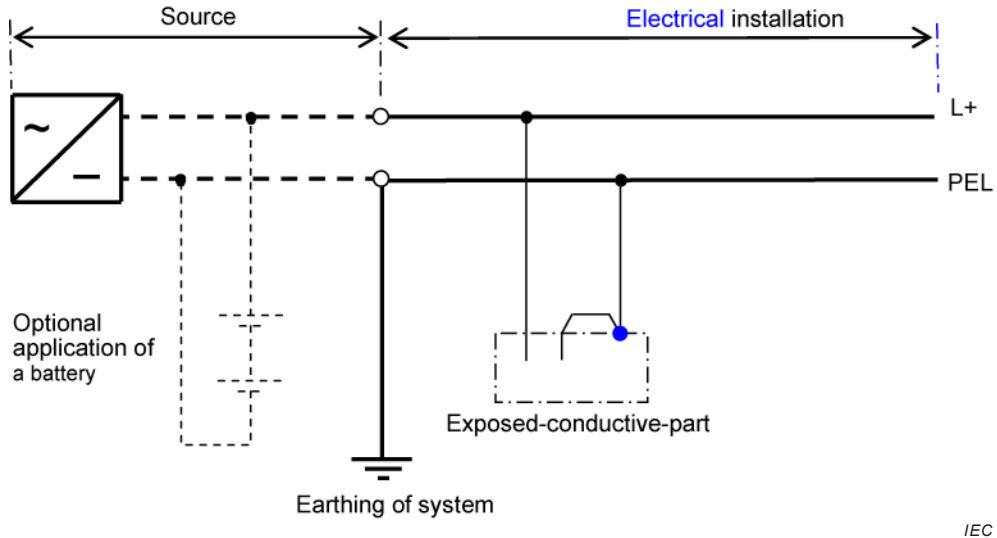

**Type b) – 3-wire**

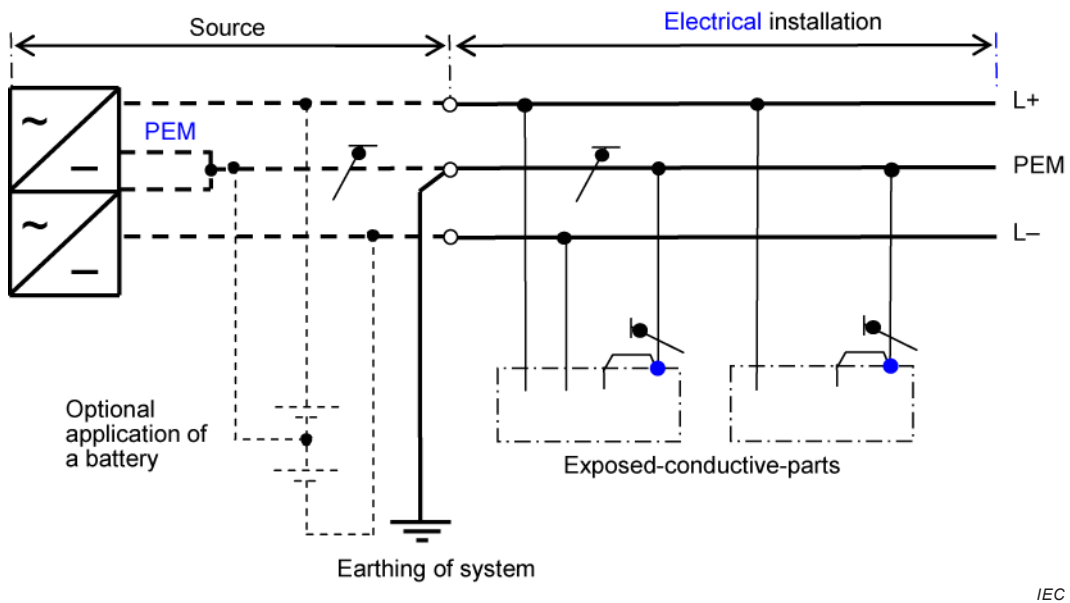

NOTE Additional earthing of the PEL conductor or the PEM conductor in the electrical installation may be provided.

**Figure B.14 – TN-C d.c. system**



**B.2.4.4 TN-C-S-system**

The functions of the earthed line conductor LE- and of the protective conductor in the system of type a) are combined in one single PEL conductor in a part of the electrical installation, or the earthed mid-wire conductor M and the protective conductor in the system of type b) are combined in one single PEM conductor in a part of the electrical installation.

The PEL conductors and PEM conductors are not allowed in the electrical installations of residential premises, public premises, commercial premises, medical locations.

**Type a) – 2-wire**

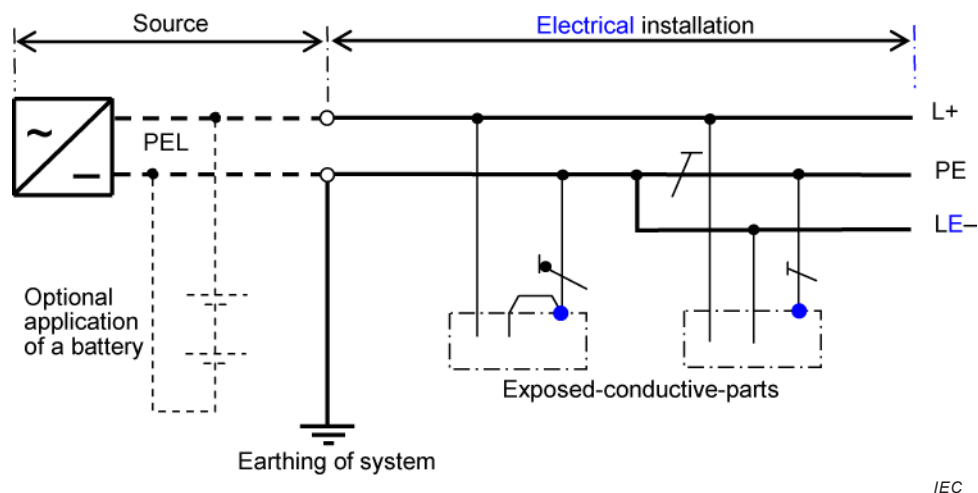

**Type b) – 3-wire**

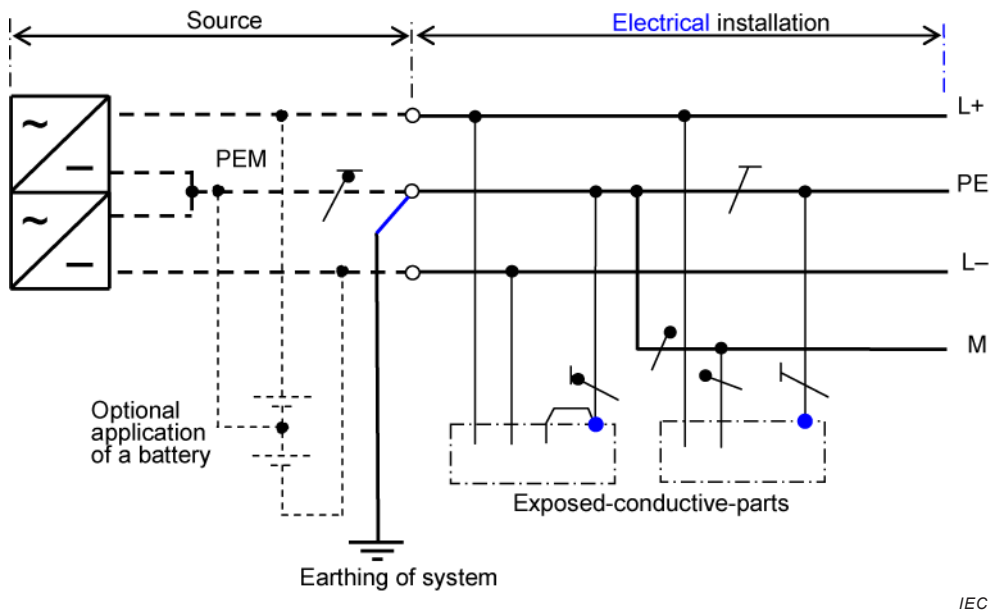

NOTE Additional earthing of the protective conductor PE in the electrical installation may be provided.

**Figure B.15 – TN-C-S d.c. system**

**B.2.4.5 TT-system**

One live part of the power source is earthed. The exposed-conductive-parts of the electrical installation are earthed by connection to earth electrodes electrically independent from the earth electrode of the power source.

**Type a) – 2-wire**

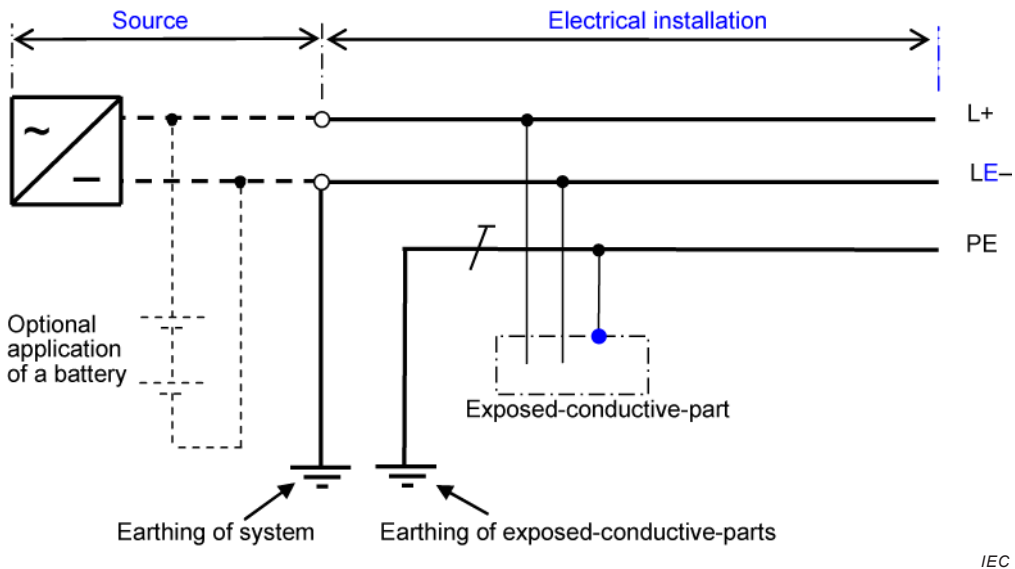

**Type b) – 3-wire**

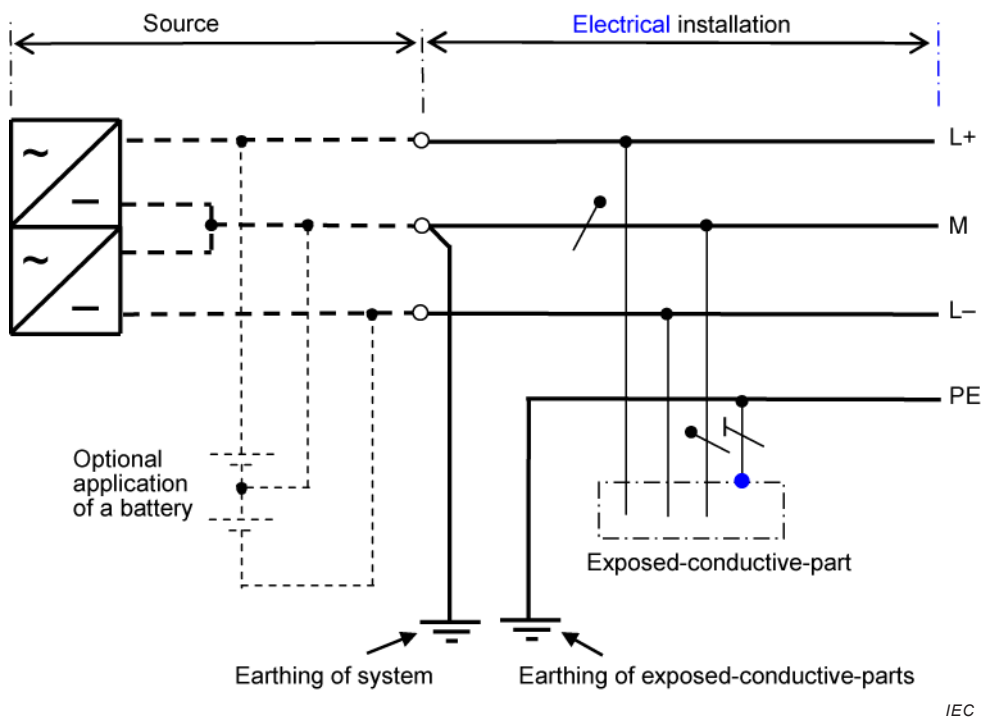

NOTE Additional earthing of the protective conductor PE in the electrical installation may be provided.

**Figure B.16 – TT d.c. system**

## **Annex C** (informative)

### **Classification of electrical equipment**

#### **C.1 Classification of residual current devices (RCDs)** (see IEC 61008, IEC 61009, IEC 60755, IEC 60947-2, IEC 62423)

Residual Current Devices (RCDs) are classified according to a number of criteria including the following:

- a) Classification according to the presence of integral over current protection
  - RCBOs: Residual current operated circuit-breakers with integral over current protection
  - RCCBs: Residual current operated circuit-breakers without integral over current protection
- b) Classification according to the method of operation
  - Functionally independent of the line voltage
  - Functionally dependent of the line voltage
    - Opening automatically in case of failure of the line voltage with or without delay
    - Not opening automatically in case of failure of the line voltage
- c) Classification according to the type of installation
  - For fixed installation and fixed wiring
  - For mobile installation and corded connexion
- d) Classification according to the number of poles and current paths
- e) Classification according to the possibility of adjusting the residual operating current
- f) Classification according to the resistance to unwanted tripping due to voltage surges
  - General type
  - Type S (increased resistance to unwanted tripping)
- g) Classification according to time-delay
  - Without time delay
  - With time delay: type S for selectivity
- h) Classification according to behavior in presence of d.c. components

DC components are caused by the rectifier devices now increasingly forming part of equipment. These d.c. components may diminish the sensitivity of certain differential devices or even completely inhibit operation by saturating their magnetic circuits. For this reason, four types of differential devices – AC, A, F and B – have been adopted by the relevant standards, as follows:

#### 1) AC type

Device for which tripping is ensured for residual sinusoidal alternating current, whether suddenly applied or slowly rising.

#### 2) A type

Device for which tripping is ensured for

- residual sinusoidal alternating current
- residual pulsating direct current

- for residual pulsating direct currents superimposed by a smooth direct current of 0,006 A,

with or without phase-angle control, independent of polarity, whether suddenly applied or slowly rising.

### 3) F type

Residual current device for which tripping is ensured as for Type A according to IEC 61008-1 or IEC 61009-1, as applicable, and in addition,

- for composite residual currents, whether suddenly applied or slowly rising intended for circuit supplied between phase and neutral or phase and earthed middle conductor;
- and for residual pulsating direct currents superimposed on smooth direct current of 0,01 A.

### 4) B type

Residual current device for which tripping is ensured as for Type F and in addition,

- for residual sinusoidal alternating currents up to 1 000 Hz;
- for residual alternating currents superimposed on a smooth direct current of 0,4 times the rated residual current ( $I_{\Delta n}$ );
- for residual pulsating direct currents superimposed on a smooth direct current of 0,4 times the rated residual current ( $I_{\Delta n}$ ) or 10 mA, whichever is the highest value;
- for residual direct currents which may result from rectifying circuits, i.e.;
- two-pulse bridge connection line to line for 2-, 3- and 4-pole devices;
- three-pulse star connection or six-pulse bridge connection for 3- and 4-pole devices;
- for residual smooth direct currents.

## C.2 Classification of circuit breakers for a.c. operation (see IEC 60898-1, IEC 60947-2)

Circuit breakers for overcurrent protection are classified according to a number of criteria including the following:

- Classification according to the number of poles
- Classification according to the instantaneous tripping current
  - Instantaneous tripping current.
  - Minimum value of current causing the circuit-breaker to operate automatically without intentional time-delay.
- Classification according to the  $I^2t$  characteristic

The  $I^2t$  characteristic is the curve giving the maximum value of  $I^2t$  as a function of the prospective current under stated conditions of operation.

Standard ratings:

- Rated short-circuit capacity
- Rated current
- Rated operational voltage
- Ranges of instantaneous tripping

Standard ranges of instantaneous tripping current are given hereunder (see IEC 60898-1):

- B type: above  $3 I_n$  up to and including  $5 I_n$
- C type: above  $5 I_n$  up to and including  $10 I_n$

- D type: above  $10 I_n$  up to and including  $20 I_n$

### C.3 Classification of surge protective devices (see IEC 61643-11)

Surge Protective Devices (SPDs) are classified according to a number of criteria including the following:

- a) Classification according to number of ports
  - one-port SPD: SPD connected in shunt with the circuit to be protected
  - two-port SPD: SPD with two sets of terminal, input and output.
- b) Classification according to design topology
  - voltage switching type SPD: spark gaps, gas tubes, thyristors and triacs
  - voltage limiting type SPD: varistors and suppressor diodes.
- c) Classification according to test class
  - Class I test is intended to simulate partial conducted lightning current impulses. SPDs subjected to Class I test methods are generally recommended for locations at points of high exposure, e.g. line entrances to buildings protected by LPS.
  - SPDs tested to class II or III test methods are subjected to impulses of shorter duration. These SPDs are generally recommended for locations with lesser exposure.
- d) Classification according to location and accessibility
  - indoor or outdoor
  - accessible or out-of-reach.
- e) Classification according to disconnecter location and function

A SPD disconnecter is a device for disconnecting an SPD from the system in the event of SPD failure. It is to prevent a persistent fault on the system and to give visible indication of the SPD failure.
- f) Classification according to temperature range
  - Normal or extended.
- g) Standard ratings
  - Impulse current (class I tests)/Nominal discharge current (for class II tests)/ Open circuit voltage (class III tests).
  - Voltage protection levels.
  - r.m.s. or d.c. maximum continuous operating voltage.

## Annex D (informative)

### General information concerning protection against lightning

#### D.1 General

Lightning acts in different ways, depending on whether the structure is struck directly or not (see Figure D.1).

- direct strokes inflicting mechanical damage and at the same time generating an increase in potential along the structures hit and around the point of impact,
- indirect strokes, source of over voltages that may result in remote destruction via a number of different propagation channels (air, soil, conductors, etc.).

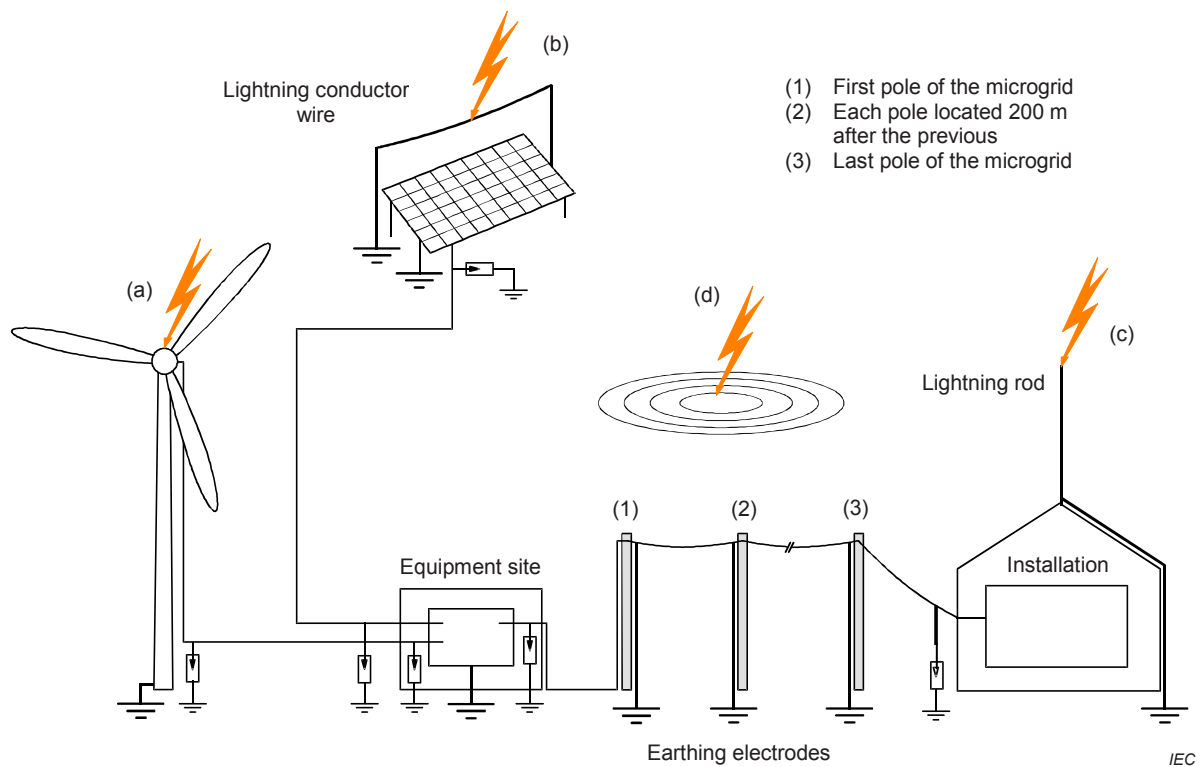

#### Key

- (a) Lightning stroke on wind generator
- (b) Lightning stroke on a photovoltaic panel
- (c) Direct stroke on a structure
- (d) Electromagnetic coupling between the lightning current and the distribution line and/or the installation cabling system

**Figure D.1 – Example of effects of a lightning stroke**

NOTE The electromagnetic coupling can be conductive or inductive.

Conductive coupling: the lightning strikes the soil near an installation and part of the lightning current is injected into the system through its earth electrodes.

Inductive coupling: the lightning strikes the soil near the installation and generates over voltages in the system by magnetic induction.

For each of the propagation modes, a combination of protective measures is to be applied (suitably adapted means and rules) to limit the direct and indirect effects of lightning to levels for the safety of persons, the protection and the operation of equipment.

General basic information regarding surge over voltages and surge protection in low voltage a.c. power systems is given in IEC 62066.

General principles for the protection of structures against lightning are given in the IEC 62305 series.

## **D.2 Protection against lightning – Principles**

Installing a lightning protection system on a building (LPS) usually results in implementing:

- An external lightning protection system (ELPS).
- Surge protective devices. These devices are located at the different links between the structures and their environment: mainly the power networks and data transmission cables.
- A unique earthing arrangement. This is necessary to limit the potential differences at any point on a site, and achieved by:
  - interconnecting the earth termination of the elps to the earthing arrangement with short connexions;
  - bonding of metal enclosures and screening;
  - metal pipes and cables should enter the buildings at the same place. metal sheets, screens, metal pipes and connections of these parts should be bonded and connected to the earthing arrangement with low impedance conductors;
  - connecting all the metal elements of the structure to the earthing arrangement.

## Bibliography

IEC 60050-826:2004, *International Electrotechnical Vocabulary (IEV) – Part 826: Electrical installations*

IEC 60364-1:2005, *Low-voltage electrical installations – Part 1: Fundamental principles, assessment of general characteristics, definitions*

IEC 60664-1:2007, *Insulation coordination for equipment within low voltage systems – Part 1: Principles, requirements and tests*

IEC TR 60755, *General requirements for residual current operated protective devices*

IEC 60898-1, *Electrical accessories – Circuit-breakers for overcurrent protection for household and similar installations – Part 1: Circuit-breakers for a.c. operation*

IEC 60947-2:2006, *Low-voltage switchgear and controlgear – Part 2: Circuit-breakers*

IEC 60947-2:2006/AMD1:2009

IEC 60947-2:2006/AMD2:2013

IEC 61008-1:2010, *Residual current operated circuit-breakers without integral overcurrent protection for household and similar uses (RCCBs) – Part 1: General rules*

IEC 61008-1:2010/AMD1:2012

IEC 61008-1:2010/AMD2:2013

IEC 61009-1:2010, *Residual current operated circuit-breakers with integral overcurrent protection for household and similar uses (RCBOs) – Part 1: General rules*

IEC 61009-1:2010/AMD1:2012

IEC 61009-1:2010/AMD2:2013

IEC 61439-1, *Low-voltage switchgear and controlgear assemblies – Part 1: General rules*

IEC 61643-11, *Low-voltage surge protective devices – Part 1: Surge protective devices connected to low-voltage power systems – Requirements and tests methods*

IEC 61643-12, *Low-voltage surge protective devices – Part 12: Surge protective devices connected to low-voltage power distribution systems – Selection and application principles*

IEC TR 62066, *Surge overvoltages and surge protection in low-voltage a.c. power systems – General basic information*

IEC 62257-9, *Recommendations for renewable energy and hybrid systems for rural electrification – Part 9: Integrated systems*

IEC 62305 (all parts): *Protection against lightning*

IEC 62423, *Type F and type B residual current operated circuit-breakers with and without integral overcurrent protection for household and similar uses*

---





# British Standards Institution (BSI)

BSI is the national body responsible for preparing British Standards and other standards-related publications, information and services.

BSI is incorporated by Royal Charter. British Standards and other standardization products are published by BSI Standards Limited.

## About us

We bring together business, industry, government, consumers, innovators and others to shape their combined experience and expertise into standards-based solutions.

The knowledge embodied in our standards has been carefully assembled in a dependable format and refined through our open consultation process. Organizations of all sizes and across all sectors choose standards to help them achieve their goals.

## Information on standards

We can provide you with the knowledge that your organization needs to succeed. Find out more about British Standards by visiting our website at [bsigroup.com/standards](http://bsigroup.com/standards) or contacting our Customer Services team or Knowledge Centre.

## Buying standards

You can buy and download PDF versions of BSI publications, including British and adopted European and international standards, through our website at [bsigroup.com/shop](http://bsigroup.com/shop), where hard copies can also be purchased.

If you need international and foreign standards from other Standards Development Organizations, hard copies can be ordered from our Customer Services team.

## Subscriptions

Our range of subscription services are designed to make using standards easier for you. For further information on our subscription products go to [bsigroup.com/subscriptions](http://bsigroup.com/subscriptions).

With **British Standards Online (BSOL)** you'll have instant access to over 55,000 British and adopted European and international standards from your desktop. It's available 24/7 and is refreshed daily so you'll always be up to date.

You can keep in touch with standards developments and receive substantial discounts on the purchase price of standards, both in single copy and subscription format, by becoming a **BSI Subscribing Member**.

**PLUS** is an updating service exclusive to BSI Subscribing Members. You will automatically receive the latest hard copy of your standards when they're revised or replaced.

To find out more about becoming a BSI Subscribing Member and the benefits of membership, please visit [bsigroup.com/shop](http://bsigroup.com/shop).

With a **Multi-User Network Licence (MUNL)** you are able to host standards publications on your intranet. Licences can cover as few or as many users as you wish. With updates supplied as soon as they're available, you can be sure your documentation is current. For further information, email [bsmusales@bsigroup.com](mailto:bsmusales@bsigroup.com).

## Revisions

Our British Standards and other publications are updated by amendment or revision.

We continually improve the quality of our products and services to benefit your business. If you find an inaccuracy or ambiguity within a British Standard or other BSI publication please inform the Knowledge Centre.

## Copyright

All the data, software and documentation set out in all British Standards and other BSI publications are the property of and copyrighted by BSI, or some person or entity that owns copyright in the information used (such as the international standardization bodies) and has formally licensed such information to BSI for commercial publication and use. Except as permitted under the Copyright, Designs and Patents Act 1988 no extract may be reproduced, stored in a retrieval system or transmitted in any form or by any means – electronic, photocopying, recording or otherwise – without prior written permission from BSI. Details and advice can be obtained from the Copyright & Licensing Department.

## Useful Contacts:

### Customer Services

**Tel:** +44 845 086 9001

**Email (orders):** [orders@bsigroup.com](mailto:orders@bsigroup.com)

**Email (enquiries):** [cservices@bsigroup.com](mailto:cservices@bsigroup.com)

### Subscriptions

**Tel:** +44 845 086 9001

**Email:** [subscriptions@bsigroup.com](mailto:subscriptions@bsigroup.com)

### Knowledge Centre

**Tel:** +44 20 8996 7004

**Email:** [knowledgecentre@bsigroup.com](mailto:knowledgecentre@bsigroup.com)

### Copyright & Licensing

**Tel:** +44 20 8996 7070

**Email:** [copyright@bsigroup.com](mailto:copyright@bsigroup.com)

## BSI Group Headquarters

389 Chiswick High Road London W4 4AL UK

