



BSI Standards Publication

# Artificial pollution tests on high-voltage ceramic and glass insulators to be used on d.c. systems

### **National foreword**

This Published Document is the UK implementation of IEC TS 61245:2015. It supersedes BS 7744:1994 which is withdrawn.

The UK participation in its preparation was entrusted to Technical Committee PEL/36, Insulators for power systems.

A list of organizations represented on this committee can be obtained on request to its secretary.

This publication does not purport to include all the necessary provisions of a contract. Users are responsible for its correct application.

© The British Standards Institution 2015.

Published by BSI Standards Limited 2015

ISBN 978 0 580 83553 7

ICS 29.080.10

**Compliance with a British Standard cannot confer immunity from legal obligations.**

This Published Document was published under the authority of the Standards Policy and Strategy Committee on 30 April 2015.

### **Amendments/corrigenda issued since publication**

<b>Date</b>	<b>Text affected</b>
-------------	----------------------

---



# TECHNICAL SPECIFICATION

---

**Artificial pollution tests on high-voltage ceramic and glass insulators to be used on d.c. systems**

INTERNATIONAL  
ELECTROTECHNICAL  
COMMISSION

---

ICS 29.080.10

ISBN 978-2-8322-2546-2

**Warning! Make sure that you obtained this publication from an authorized distributor.**

## CONTENTS

FOREWORD.....	4
INTRODUCTION.....	6
1 Scope.....	8
2 Normative references.....	8
3 Terms and definitions .....	8
4 General test requirements.....	11
4.1 General.....	11
4.2 Test methods .....	12
4.3 Arrangement of insulator for test.....	12
4.3.1 Test configuration .....	12
4.3.2 Insulator cleaning.....	12
4.4 Requirements for the test circuit .....	13
4.4.1 Test voltage.....	13
4.4.2 Atmospheric corrections .....	13
4.4.3 Characteristics of the measuring systems .....	13
4.4.4 Identification of flashover .....	13
5 Salt fog method .....	14
5.1 General information.....	14
5.2 Salt solution .....	14
5.3 Spraying system .....	16
5.4 Conditions before starting the test .....	19
5.5 Preconditioning process .....	19
5.6 Withstand test.....	20
5.7 Acceptance criteria for the withstand test.....	20
6 Solid layer method.....	20
6.1 General information.....	20
6.2 Main characteristics of inert materials.....	21
6.3 Composition of the contaminating suspension.....	21
6.4 Application of the pollution layer .....	22
6.5 Determination of the degree of pollution of the test insulator .....	23
6.6 Test procedure.....	23
6.7 Withstand test and acceptance criteria.....	24
Annex A (informative) Method for checking the uniformity of the layer .....	25
Annex B (informative) Determination of the withstand characteristics of insulators.....	27
B.1 General.....	27
B.2 Determination of the maximum withstand degree of pollution at a given test voltage.....	27
B.3 Determination of the maximum withstand voltage at a given degree of pollution.....	27
B.4 Determination of the 50 % withstand voltage at a given degree of pollution.....	28
Annex C (informative) Additional recommendations concerning the solid layer method procedures .....	29
C.1 General.....	29
C.2 Contamination practice.....	29
C.3 Drying of the pollution layer .....	29
C.4 Checking the wetting action of the fog .....	29

C.5	Checking fog uniformity for large or complex test objects .....	30
C.6	Fog input to the test chamber .....	30
C.7	Duration of the withstand test .....	31
C.8	Evaluation of the reference salt deposit density ( <i>SDD</i> ).....	31
Annex D (informative) Information to check equipment for artificial pollution tests .....		32
Annex E (informative) Supplementary information on artificial pollution tests on insulators for voltage systems of $\pm 600$ kV and above (solid layer method procedure B) .....		34
E.1	General.....	34
E.2	Test chamber .....	34
E.3	Fog generator .....	34
E.4	Wetting action and uniformity of fog density .....	34
E.5	Test of very large insulators .....	34
Annex F (informative) Further investigation .....		35
Bibliography .....		36
Figure 1 – Ripple amplitude and actual mean voltage, measured on a resistive load absorbing 100 mA.....		9
Figure 2 – Voltage drop and voltage overshoot and leakage current.....		14
Figure 3 – Value of factor b versus solution temperature $\theta$ .....		16
Figure 4 – Typical construction of fog spray nozzle.....		18
Figure 5 – Test layout for inclined insulators.....		19
Figure A.1 – Arrangement of the probe electrodes .....		25
Figure A.2 – Circuit diagram of the meter .....		26
Figure C.1 – Determination of layer conductance and evaluation of its rise time $T_C = t_2 - t_1$ .....		31
Table 1 – Salt-fog method: correspondence between the value of salinity and volume conductivity of the solution at a temperature of 20 °C .....		15
Table 2 – Main characteristics of the inert materials used in solid layer suspensions .....		21
Table 3 – Kaolin (or Tonoko) composition: approximate correspondence between the reference degrees of pollution on the insulator and the volume conductivity of the suspension at a temperature of 20 °C.....		22
Table D.1 – (Provisional) .....		33

## INTERNATIONAL ELECTROTECHNICAL COMMISSION

**ARTIFICIAL POLLUTION TESTS ON HIGH-VOLTAGE CERAMIC  
AND GLASS INSULATORS TO BE USED ON D.C. SYSTEMS**

## FOREWORD

- 1) The International Electrotechnical Commission (IEC) is a worldwide organization for standardization comprising all national electrotechnical committees (IEC National Committees). The object of IEC is to promote international co-operation on all questions concerning standardization in the electrical and electronic fields. To this end and in addition to other activities, IEC publishes International Standards, Technical Specifications, Technical Reports, Publicly Available Specifications (PAS) and Guides (hereafter referred to as "IEC Publication(s)"). Their preparation is entrusted to technical committees; any IEC National Committee interested in the subject dealt with may participate in this preparatory work. International, governmental and non-governmental organizations liaising with the IEC also participate in this preparation. IEC collaborates closely with the International Organization for Standardization (ISO) in accordance with conditions determined by agreement between the two organizations.
- 2) The formal decisions or agreements of IEC on technical matters express, as nearly as possible, an international consensus of opinion on the relevant subjects since each technical committee has representation from all interested IEC National Committees.
- 3) IEC Publications have the form of recommendations for international use and are accepted by IEC National Committees in that sense. While all reasonable efforts are made to ensure that the technical content of IEC Publications is accurate, IEC cannot be held responsible for the way in which they are used or for any misinterpretation by any end user.
- 4) In order to promote international uniformity, IEC National Committees undertake to apply IEC Publications transparently to the maximum extent possible in their national and regional publications. Any divergence between any IEC Publication and the corresponding national or regional publication shall be clearly indicated in the latter.
- 5) IEC itself does not provide any attestation of conformity. Independent certification bodies provide conformity assessment services and, in some areas, access to IEC marks of conformity. IEC is not responsible for any services carried out by independent certification bodies.
- 6) All users should ensure that they have the latest edition of this publication.
- 7) No liability shall attach to IEC or its directors, employees, servants or agents including individual experts and members of its technical committees and IEC National Committees for any personal injury, property damage or other damage of any nature whatsoever, whether direct or indirect, or for costs (including legal fees) and expenses arising out of the publication, use of, or reliance upon, this IEC Publication or any other IEC Publications.
- 8) Attention is drawn to the normative references cited in this publication. Use of the referenced publications is indispensable for the correct application of this publication.
- 9) Attention is drawn to the possibility that some of the elements of this IEC Publication may be the subject of patent rights. IEC shall not be held responsible for identifying any or all such patent rights.

The main task of IEC technical committees is to prepare International Standards. In exceptional circumstances, a technical committee may propose the publication of a technical specification when

- the required support cannot be obtained for the publication of an International Standard, despite repeated efforts, or
- the subject is still under technical development or where, for any other reason, there is the future but no immediate possibility of an agreement on an International Standard.

Technical specifications are subject to review within three years of publication to decide whether they can be transformed into International Standards.

IEC TS 61245, which is a technical specification, has been prepared by IEC technical committee 36: Insulators.

This second edition cancels and replaces the first edition published in 1993. This edition constitutes a technical revision.

This edition includes the following significant technical changes with respect to the previous edition:

- a) Corrections and the addition of explanatory material;
- b) The addition of Clause 4.4.2 on atmospheric correction;
- c) The change of upper limit of volume conductivity of tap water for insulator cleaning to 0,1 S/m;
- d) The extension to UHV voltages; and
- e) The addition of Annex B "Determination of the withstand characteristics of insulators" and Annex E "Supplementary information on artificial pollution tests on insulators for voltage systems of  $\pm 600$  kV and above (solid layer method procedure B)

The text of this technical specification is based on the following documents:

Enquiry draft	Report on voting
36/352/DTS	36/359/RVC

Full information on the voting for the approval of this technical specification can be found in the report on voting indicated in the above table.

This publication has been drafted in accordance with the ISO/IEC Directives, Part 2.

The committee has decided that the contents of this publication will remain unchanged until the stability date indicated on the IEC website under "<http://webstore.iec.ch>" in the data related to the specific publication. At this date, the publication will be

- transformed into an International standard,
- reconfirmed,
- withdrawn,
- replaced by a revised edition, or
- amended.

A bilingual version of this publication may be issued at a later date.

## INTRODUCTION

The electrical strength of d.c. insulation under pollution conditions determines, in many cases, the dimensions and the design of the insulation.

The d.c. test procedures as specified in this technical specification follow closely the ones established for a.c. by IEC 60507. This does not exclude the possibility that at a later time other d.c. test procedures will be defined.

The main differences between this technical specification and IEC 60507 are:

- test circuit requirements include ripple factor, voltage drop and voltage overshoot. No requirements are made for the minimum short circuit current or ratio between short circuit and leakage currents;
- different criteria for the identification of flashover are given;
- for the salt fog test, a pre-conditioning process with d.c. voltage may be used by agreement;
- the wetting rate, rather than the steam injection rate, is prescribed; the measurement of the layer conductance is used to check the wetting action of the fog;
- as regards the solid layer methods, only the test procedure type "B" is considered due to the high scatter of the results obtained with tests carried out according to the type "A" procedure.

The tests are deemed to be not a suitable measure to prove the insulation performance of polymeric or special types of insulators (e.g. insulators with semiconducting glaze or covered with any organic insulating material) under polluted conditions. The test procedures given in this standard do not take account of the different properties of insulators such as surface hydrophobicity and hydrophobicity transfer through the pollution layer etc. These questions are under consideration by CIGRE SC D1.

For the test methods described in this technical specification, it is recommended that the voltage for the withstand voltage tests be specified as the highest value of operating voltage which occurs under normal operating conditions. Other test voltages may be agreed upon. If not otherwise specified and agreed between the parties, voltage of the negative polarity will be applied.

Only those test methods in which the voltage is held constant during the whole test are considered suitable for standardization. Variants in which the voltage is raised continuously to flashover are not included in this technical specification.

The leakage current may be used for interpretation of the test results, and therefore it is recommended that this current be continuously measured during the artificial pollution tests.

To achieve repeatable results, the artificial layer for d.c. pollution tests should be as uniform as possible, since non-uniformity can influence d.c. withstand and flashover voltages.

The amount of non-soluble material on the insulator surface may affect the test results. Although this matter is under consideration and no requirements can be given, the definition of non-soluble deposit density has been introduced into this technical specification for reference.

The type and quantity of non-soluble material, the steam rate and the preconditioning procedure with salt fog (either by a.c. or d.c. voltage) may affect the test results.



The standard results are intended as results obtained in laboratories close to sea level (altitude  $\leq 1\,000$  m). Test results obtained at higher altitude or in test chambers with non-standard air densities are to be corrected for air density.

# ARTIFICIAL POLLUTION TESTS ON HIGH-VOLTAGE CERAMIC AND GLASS INSULATORS TO BE USED ON D.C. SYSTEMS

## 1 Scope

This technical specification is applicable for the determination of the d.c. withstand characteristics of ceramic and glass insulators to be used outdoors and exposed to polluted atmospheres, on d.c. systems with the highest voltage of the system greater than  $\pm 1\,000\text{ V}$ .

These tests are not applicable to polymeric insulators, to greased insulators or to special types of insulators (e.g. insulators with semiconducting glaze or covered with any organic insulating material).

The object of this technical specification is to prescribe procedures for artificial pollution tests applicable to insulators for overhead lines, substations and traction lines and to bushings.

It may also be applied to hollow insulators with suitable precautions to avoid internal flashover. In applying these procedures to apparatus incorporating hollow insulators, the relevant technical committees should consider their effect on any internal equipment and the special precautions which may be necessary.

## 2 Normative references

The following documents, in whole or in part, are normatively referenced in this document and are indispensable for its application. For dated references, only the edition cited applies. For undated references, the latest edition of the referenced document (including any amendments) applies.

IEC TS 60815-1, *Selection and dimensioning of high-voltage insulators intended for use in polluted conditions – Part 1: Definitions, information and general principles*

IEC 60060-1, *High-voltage test techniques – Part 1: General definitions and test requirements*

IEC 60060-2, *High-voltage test techniques – Part 2: Measuring systems*

## 3 Terms and definitions

For the purpose of this technical specification, the following terms and definitions apply.

### 3.1

#### individual test

one single process consisting in applying to the object a specified test voltage, for a specified time or until flashover occurs, at a specified degree of pollution

### 3.2

#### actual mean voltage

$U_a$

mean value of the voltage at a given instant over a time interval ending at the instant considered and having a duration equal to that of one cycle of the alternating voltage supplying the rectifier

Note 1 to entry: When it is not possible to determine the cycle of the supply voltage, the time interval is 20 ms.

### 3.3 test voltage

$U_t$   
actual mean voltage at the beginning of an individual test

### 3.4 ripple

periodic deviation from the arithmetic mean value of the test voltage

### 3.5 ripple amplitude

$U_r$   
half the difference between maximum and minimum values

### 3.6

**ripple factor**  
ratio of the ripple amplitude to the actual mean voltage

See:  $U_r/U_a$  in Figure 1

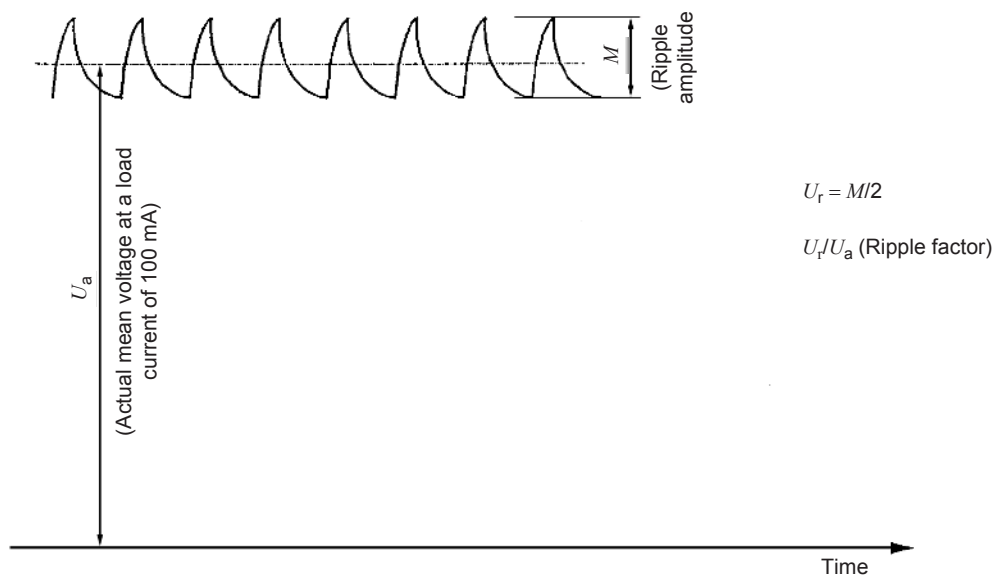

IEC

**Figure 1 – Ripple amplitude and actual mean voltage, measured on a resistive load absorbing 100 mA**

### 3.7 voltage drop

$\Delta u_t$   
difference between the test voltage and the actual mean voltage

See: Figure 2

### 3.8

**relative voltage drop**  
ratio of the voltage drop  $\Delta u_t$  to the test voltage ( $U_t$ ) usually expressed as a percentage

**3.9****voltage overshoot**

difference between the actual mean voltage and the test voltage

See: Figure 2

**3.10****relative voltage overshoot**

ratio of the voltage overshoot to the test voltage  $U_t$ , usually expressed as a percentage

**3.11****leakage current**

current measured in series with the insulator surface at its earth end during a pollution test

**3.12****short circuit current**

current delivered by the complete testing circuit, when the test object is energized at the test voltage and then short-circuited

**3.13****salinity** $S_a$ 

concentration of the solution of salt in tap water, expressed by the amount of salt divided by the volume of solution

Note 1 to entry: This is generally expressed in kg/m<sup>3</sup>.

**3.14****pollution layer**

conducting electrolytic layer on the insulator surface, composed of salt plus non-soluble materials

**3.15****layer conductance** $G_L$ 

ratio current/voltage measured as specified in Annex C.3

**3.16****salt deposit density****SDD**

amount of salt in the deposit on a given surface of the insulator (metal parts and assembling materials are not to be included in this surface), divided by the area of this surface

Note 1 to entry: See 6.5.

Note 2 to entry: This is generally expressed in mg/cm<sup>2</sup>.

**3.17****non-soluble deposit density****NSDD**

amount of non-soluble material in the deposit on a given surface of the insulator (metal parts and assembling materials are not to be included in this surface), divided by the area of this surface

Note 1 to entry: This is generally expressed in mg/cm<sup>2</sup>.

**3.18****degree of pollution**

value of the quantity (salinity, salt deposit density) which characterizes the artificial pollution applied to the test insulator

**3.19****reference salinity**

value of the salinity used to characterize an individual test

**3.20****reference salt deposit density**

value of the salt deposit density used to characterize an individual test

Note 1 to entry: This is defined as the average of the salt deposit density values measured on a few insulators (or on parts of them), which are chosen for this purpose from among the contaminated ones prior to their submission to any test.

**3.21****specified withstand degree of pollution**

reference degree of pollution at which an insulator shall withstand the specified test voltage in at least three individual tests out of four, under the conditions described in the relevant Subclauses 5.6 or 6.7

**3.22****maximum withstand degree of pollution**

highest degree of pollution at which an insulator has withstood at least three individual tests out of four at the specified test voltage, under the conditions described in Clause B.1

**3.23****maximum withstand voltage**

highest test voltage at which an insulator has withstood at least three individual withstand tests out of four at the specified degree of pollution, under the conditions described in Clause B.2

**3.24****50 % withstand voltage**

test voltage at which an insulator has 50 % probability to withstand one individual test

Note 1 to entry: See Clause B.3.

## **4 General test requirements**

### **4.1 General**

Pollution tests can be carried out for two main objectives:

- to obtain information about the pollution performance of insulators e.g. for comparison of different insulator types/profile;
- to check the performance in a configuration as close as possible to the in-service conditions.

To reach the first objective, tests on relatively short insulator sets (e.g. arcing distance  $\geq 1,5$  m – if representative of the full set in terms of radial geometry and profile) may be sufficient.

Tests to reach the second objective may be agreed between the manufacturer and the user whenever optimisation of the design is necessary and/or whenever it is expected that the mounting condition or the inner active parts in apparatus can affect the performance. Such tests shall be made simulating the relevant service conditions as closely as possible. In particular tests in other positions from the vertical (inclined, horizontal) duplicating actual service conditions may be agreed between the supplier and the user.

Tests at higher system voltages (of  $\pm 600$  kV and above) may present particular requirements as reported in Annex E.

## 4.2 Test methods

The two following pollution test methods are recommended for standard tests:

- the salt fog method (Clause 5) in which the insulator is subjected to a defined ambient pollution;
- the solid layer method (Clause 6) in which a fairly uniform layer of a defined solid pollution is deposited on the insulator surface.

In these test methods the voltage is held constant for a period of at least several minutes. Variants in which the voltage is raised continuously to flashover are not standardized but may be used for special purposes.

NOTE In testing of full scale insulators for system voltages of higher than  $\pm 600$  kV experiences with salt-fog method are not available yet. The application of solid layer method is therefore preferred. More information on the solid layer method for such insulators are given in Annex E.

## 4.3 Arrangement of insulator for test

### 4.3.1 Test configuration

The vertical position is in general suggested for comparison of different insulator types. Tests in other positions (inclined, horizontal) reproducing actual service conditions may be carried out when agreed between the manufacturer and the purchaser. When there are special reasons not to test insulators in the vertical position (e.g. wall bushings and circuit-breaker longitudinal insulation), only the service position shall be considered.

The minimum clearances between any part of the insulator and any earthed object other than the structure which supports the insulator and the columns of the nozzles, when used, shall be not less than 0,5 m per 100 kV of the test voltage and, in any case, not less than 1,5 m.

The configuration of the supporting structure and the energized metal parts, at least within the minimum clearance from the insulator, shall reproduce those expected in service.

As regards their influence on the test results, the available experience indicates that:

- external components, e.g. fittings, do not significantly affect the results;
- the internal components may affect the withstand value namely with low pollution severity.

### 4.3.2 Insulator cleaning

The insulator shall be carefully cleaned so that all traces of dirt and grease are removed. After cleaning, the insulating parts of the insulator shall not be touched by unprotected hand.

The surface of the insulator is deemed to be sufficiently clean and free from any grease if large continuous wet areas are observed after rinsing.

In the case of the solid-layer method, before the first contamination, scrubbing with a slurry of water and inert material such as kaolin shall be done, after which the insulator shall be thoroughly rinsed with tap water. A detergent may be added to the slurry.

Before every subsequent contamination, the insulator shall again be thoroughly washed with tap water only. Hand wiping might be necessary, if either the SDD-levels or the test results become inconsistent.

In the case of the salt-fog method, water, preferably heated to about 50 °C, with the addition of trisodium phosphate or other detergent, shall be used, after which the insulator shall be thoroughly rinsed with tap water. Before this final treatment, scrubbing as for the solid-layer method may be done if necessary.

When the volume conductivity of tap water is higher than 0,1 S/m, demineralized water shall be used.

NOTE If necessary, the metal parts and the assembling materials can be painted with a salt-water resistant paint to ensure that no corrosion products wash down on to the insulating surface during a test.

#### 4.4 Requirements for the test circuit

##### 4.4.1 Test voltage

Throughout the test, the insulator shall be continuously energized at the specified test voltage and polarity.

The ripple factor of the test voltage demonstrated in a suitable way shall be  $\leq 3\%$  for a current of 100 mA with a resistive load (Figure 1).

The relative voltage drop (Figure 2) occurring during individual tests resulting in withstand shall not exceed 10 %.

The relative voltage overshoot (Figure 2), usually due to load- release caused by extinction of electrical discharges on the insulator surface, shall not exceed 10 %.

If a flashover occurs during the time when a relative voltage overshoot is between 5 % and 10 %, the test is not valid.

The voltage measurement shall be carried out by voltage divider according to IEC 60060-2 suitable to measure continuous voltage and transients with required accuracy.

##### 4.4.2 Atmospheric corrections

No humidity correction factor shall be applied. Test voltages shall be corrected for air density according to IEC 60060-1. The coefficient  $m$  is however still under investigation.

NOTE 1 The temperature in test chamber for relative air density calculation is temperature measured at the height of the test object before the test.

NOTE 2 The coefficient  $m$  depends on many factors such as pollution severity and insulator characteristics. For the time being provisionally reference can be made to value  $m = 0,35$  [1]<sup>1</sup>.

NOTE 3 Atmospheric correction factors for polluted insulators are presently under consideration by CIGRE SC D1.

##### 4.4.3 Characteristics of the measuring systems

The systems used for measuring voltage and leakage current shall have an upper limiting frequency of at least 1 kHz.

##### 4.4.4 Identification of flashover

The complete bridging of the insulator under test by the short-circuit arc in the case of apparent flashover shall be demonstrated. One of the following criteria is sufficient:

- the voltage recording clearly indicates a breakdown to arc-voltage;
- the current measurements indicate the short-circuit of the complete circuit by an arc;
- the peak value of the current of the test circuit, measured in the microsecond range with a shunt resistor of suitable response, is higher than  $0,5 U_t/R_S$ ;

---

<sup>1</sup> Numbers in square brackets refer to the bibliography.

- photographic or video recordings with sufficient resolution clearly show the complete short-circuit arc.

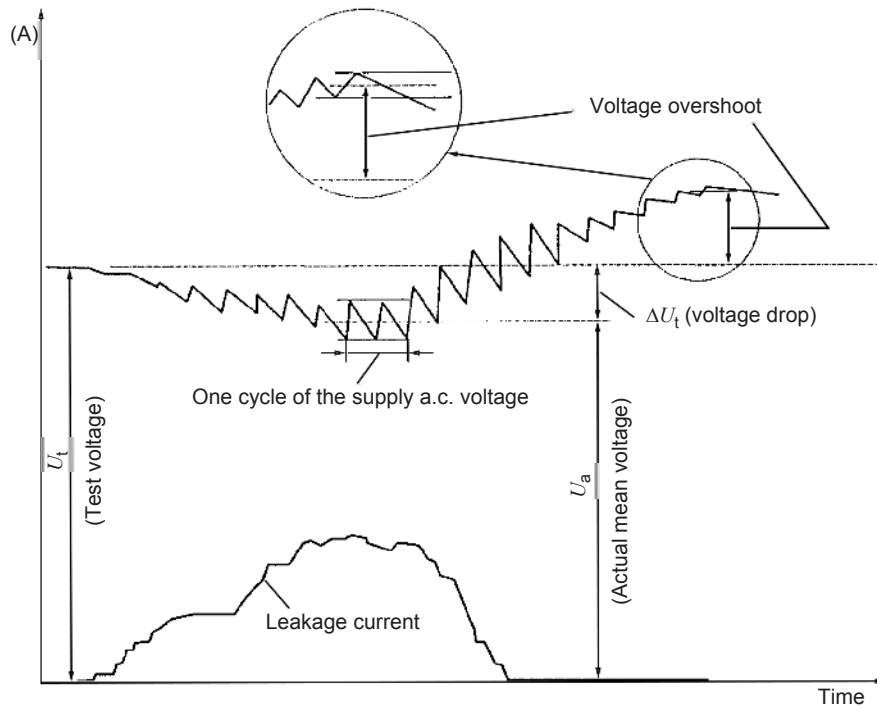

IEC

**Figure 2 – Voltage drop and voltage overshoot and leakage current**

## 5 Salt fog method

### 5.1 General information

The salt fog test procedure simulates type B pollution (see IEC TS 60815-1) where a liquid conductive layer covers the insulator surface. In practice, this layer does not contain any significant insoluble material.

The degree of pollution in a test is defined by the salinity of the salt fog expressed in kg of salt (NaCl) per  $\text{m}^3$  of water.

The test consists of two parts – preconditioning process (the aim of which is cleaning of the tested insulator surface) and withstand test. The detailed description of both procedures is in 5.5 and 5.6.

The salt fog test is currently not recommended for tests of insulator configurations at system voltages of higher than  $\pm 600$  kV. Further investigations are necessary to extend the applicability of this method also to higher system voltages.

### 5.2 Salt solution

The salt solution shall be made of sodium chloride (NaCl) of commercial purity and tap water.

Tap water with high hardness, e.g. with a content of equivalent  $\text{CaCO}_3$  greater than  $350 \text{ g/m}^3$ , can cause limestone deposits on the insulator surface. In this case deionized water shall be used for preparation of the salt solution.



NOTE Hardness of tap water is measured in terms of content of equivalent  $\text{CaCO}_3$  in accordance with the Condensed Chemical Dictionary, revised by Gessner G. Hawley: Encyclopaedia of Chemistry; Van Nostrand Reinhold Company New York (USA), 1971.

The salinity to be used shall be one of the values: 2,5; 3,5; 5; 7; 10; 14; 20; 28; 40; 56; 80; 112; 160; 224  $\text{kg/m}^3$ .

The maximum permissible tolerance in salinity is  $\pm 5\%$  of the specified value. It is recommended that the salinity be determined either by measuring the conductivity or by measuring the density with a correction for temperature. Table 1 gives the correspondence between the value of salinity, volume conductivity and density of the solution at a temperature of 20 °C.

When the solution temperature is not at 20 °C, conductivity and density values shall be corrected according to formulas (1) or (2).

Care shall be taken that the temperature of the salt solution is between 5 °C and 30 °C, since no experiment is available to validate tests performed outside this range of solution temperature.

**Table 1 – Salt-fog method: correspondence between the value of salinity and volume conductivity of the solution at a temperature of 20 °C**

Salinity Sa $\text{kg/m}^3$	Volume conductivity $\sigma_{20}$ S/m
2,5	0,43
3,5	0,60
5	0,83
7	1,15
10	1,6
14	2,2
20	3,0
28	4,1
40	5,6
56	7,6
80	10
112	13
160	17
224	20

The conductivity correction shall be made using formula (1):

$$\sigma_{20} = \sigma_{\theta} [1 - b (\theta - 20)] \quad (1)$$

where:

- $\theta$  is the solution temperature (°C)
- $\sigma_{\theta}$  is the volume conductivity at a solution temperature of  $\theta$  °C (S/m)
- $\sigma_{20}$  is the volume conductivity at a solution temperature of 20 °C (S/m)
- $b$  is the factor depending on solution temperature  $\theta$ , as obtained by the following equation, and as shown in Figure 3:

$$b = 3,200 \times 10^{-8}\theta^3 + 1,032 \times 10^{-5}\theta^2 - 8,272 \times 10^{-4}\theta + 3,544 \times 10^{-2}$$

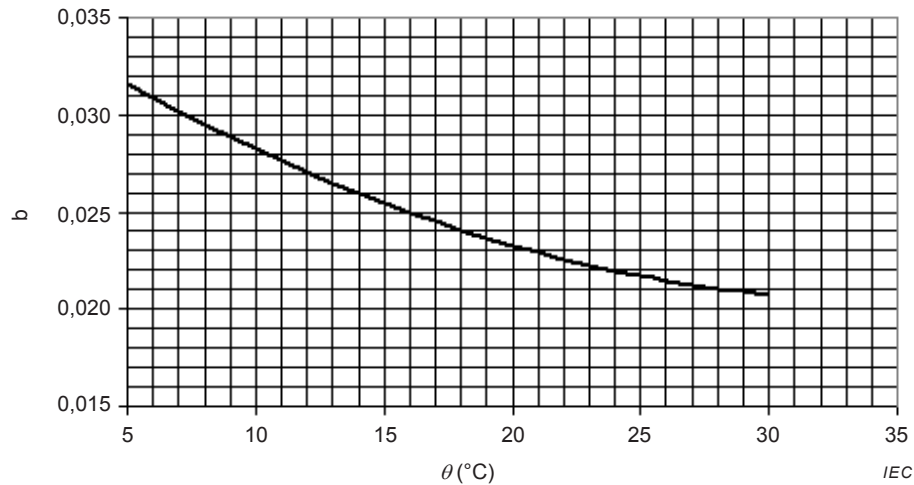

**Figure 3 – Value of factor b versus solution temperature  $\theta$**

The density correction shall be made using formula (2):

$$\Delta 20 = \Delta \theta [1 + (200 + 1,3 \text{ Sa}) (\theta - 20) \times 10^{-6}] \quad (2)$$

where:

- $\theta$  is the solution temperature (°C)
- $\Delta \theta$  is the density at a solution temperature of  $\theta$ °C (kg/m<sup>3</sup>)
- $\Delta 20$  is the density at a solution temperature of 20 °C (kg/m<sup>3</sup>)
- Sa is the salinity (kg/m<sup>3</sup>)

This correction formula is only valid for salinities over 20 kg/m<sup>3</sup>.

### 5.3 Spraying system

The fog is produced in the test chamber by means of a specified number of fog spray nozzles which atomize the solution by a stream of compressed air from the air nozzle blowing at right angles to the solution nozzle. The nozzles consist of corrosion resistant tubes, the internal diameter of the air nozzles being 1,2 mm ± 0,02 mm and the internal diameter of the solution nozzles being 2,0 mm ± 0,02 mm. Both nozzles shall have an outside diameter of 3,0 mm ± 0,05 mm and the ends of the nozzles shall be square-cut and polished.

The end of the solution nozzle shall lie on the axis of the air nozzle to within ±0,05 mm. The distance between the end of the air nozzle and the central line of the solution nozzle shall be 3 mm ± 0,05 mm. The axes of the two nozzles shall lie in the same plane to within ±0,05 mm.

Figure 4 shows a typical construction of the fog spray nozzle.

The fog spray nozzles shall be in two columns parallel to and on opposite sides of the insulator which shall have its axis in the same plane as the columns, i.e. a vertical insulator shall be tested with vertical columns and a horizontal insulator with horizontal columns. In the case of an inclined insulator (see Figure 5) the plane containing the insulator and the columns shall intersect the horizontal plane in a line at right angles to the insulator axis; in this case, the axis of the solution nozzles is vertical. The distance between the solution nozzles and the insulator axis shall be 3 m ± 0,05 m.

The fog spray nozzles shall be spaced at 0,6 m intervals, each air nozzle pointing at right angles to the column axis towards its counterpart on the other column and within an angle of 1° to the plane of the fog spray nozzles. This alignment can be checked for fog spray nozzles on vertical columns by lowering the solution nozzles, and passing water through the air nozzles and directing it towards the opposing nozzles. Then the solution nozzles are raised to the operating position. The mid-point of the insulator shall preferably be in line with the mid-points of the columns of fog spray nozzles. Both columns shall extend beyond the insulator at both ends by at least 0,6 m.

The minimum number  $N$  of fog spray nozzles per column shall be, for a length  $H$  in metres of the insulator:

$$N = \frac{H}{0,6} + 3$$

The air nozzles shall be supplied with filtered, oil-free air at a relative pressure of  $(7,0 \pm 0,35) \times 10^5$  Pa.

The flow of solution to each solution nozzle shall be  $(0,5 \pm 0,05)$  dm<sup>3</sup>/min for the period of the test and the tolerance on the total flow to all sprays shall be  $\pm 5$  % of the nominal value.

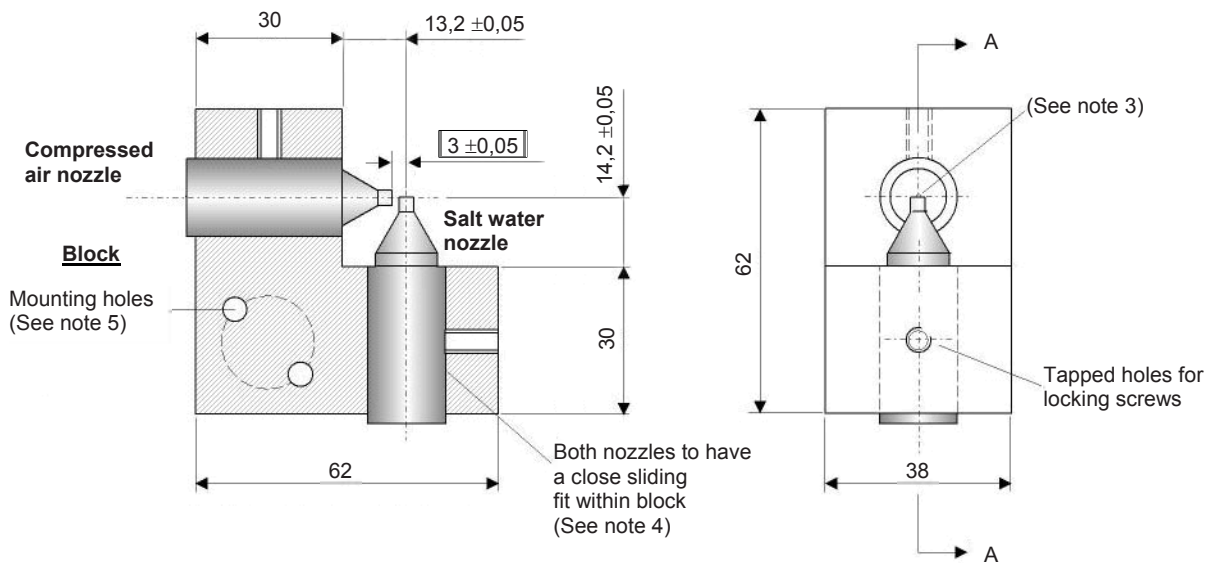

Section A-A showing nozzles in position

IEC

All dimensions in millimeters (except thread)

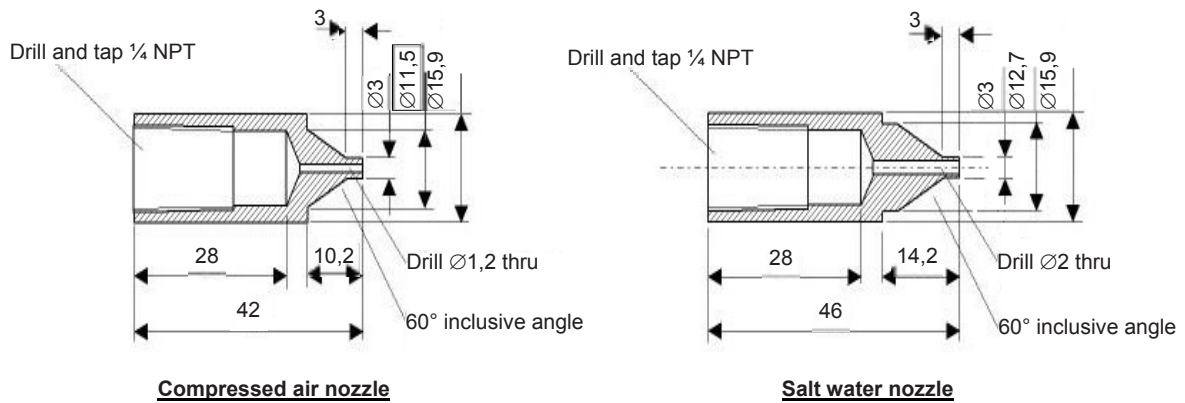

IEC

**NOTES:**

NOTE 1 Machine all over  $\pm 0,1$  mm unless stated otherwise.

NOTE 2 Concentricity of nozzles within 0,1 mm.

NOTE 3 Outer face of both nozzles to be square and polished.

NOTE 4 Finishing of nozzles in the block with a sized milling cutter is suggested to achieve the best fit.

NOTE 5 Remove all sharp edges except as Note 3.

NOTE 6 Mounting holes should be drilled through to allow unit to be positioned from either side.

NOTE 7 Unit should initially be assembled with nozzle shoulders flush with inboard surfaces of block as shown above. If required, small adjustments in the positioning of the nozzles can be made to optimize spray properties.

**HARDWARE REQUIREMENTS:**

2 off stainless steel fittings with hose barb (Swagelok No.: SS-4-HC-1-4)

2 off stainless steel set screws (as required).

Rubber hose as required with retaining clamps.

Corrosion-resistant mounting hardware (as required).

**MATERIAL REQUIREMENTS:**

Salt water nozzle – stainless steel Type 303

Compressed air nozzle – stainless steel Type 303

Block – nonabsorbent plastic\*

\*POM (polyoxymethylene) is recommended for ease of machining and dimensional stability

**Figure 4 – Typical construction of fog spray nozzle**

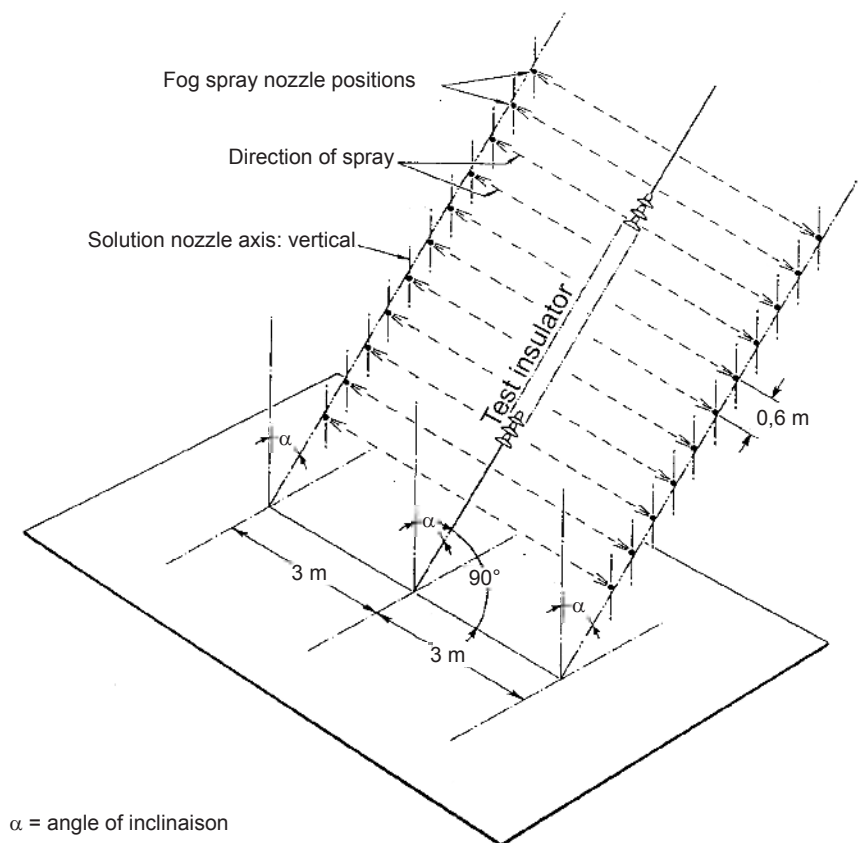

**Figure 5 – Test layout for inclined insulators**

#### 5.4 Conditions before starting the test

The test shall start while the insulator, cleaned as recommended in 4.3.2, is completely wet.

At the start of the test the insulator shall be in thermal equilibrium with the air in the test chamber. In addition the ambient temperature shall be not less than 5 °C or greater than 40 °C and its difference from the temperature of the salt solution shall not exceed 15 K.

The insulator is energized, the salt-solution pump and air compressor are switched on, and the test is deemed to have started as soon as the compressed air has reached the normal operating pressure at the nozzles.

#### 5.5 Preconditioning process

The insulator, cleaned as described in 4.3.2, is subjected to salinity equal to or higher than the one for the test, and preconditioning is carried out applying a.c. voltage. In the case of apparatus such as wall bushings, transducers and arresters, the maximum permissible a.c. preconditioning voltage shall be given by the manufacturer of the test object.

Unless the insulator flashes over earlier, the a.c. preconditioning voltage shall be maintained for 20 min. If the insulator does not flashover, the voltage shall be raised in steps of 10 % of the test voltage every 5 min until flashover or until the highest permissible preconditioning voltage is reached and maintained for 5 min.

If flashover occurs, the voltage shall be reapplied and raised as quickly as possible to 90 % of the flashover voltage just obtained and thereafter increased in steps of 5 % of the flashover voltage every 5 min until flashover occurs or the highest permissible preconditioning voltage

is reached. If flashover occurs, the latter process is repeated six further times. After the eight flashovers, the fog shall be cleared, the insulator shall be washed down with tap water and then the tests shall start as soon as possible.

Preconditioning procedure with d.c. voltage may be agreed between the parties. The number of flashovers shall be chosen using available experience.

NOTE 1 The users of this process are in agreement that the heavy current surging and the flashover itself in a flashover test removes the last traces of grease on an insulator surface after an effective cleaning process (see 4.3.2). The introduction of the preconditioning process, before the salt fog test is performed, ensures a suitable conditioning of the insulator surface.

NOTE 2 The use of d.c. for preconditioning can be problematic due to voltage source limitation in terms of voltage and current.

When test series are foreseen, the insulator shall be cleaned as described in 4.3.2 and subsequently preconditioned as described in the present clause, whenever the condition of the insulator requires it.

If the preconditioning process performed at the reference salinity requires excessively high voltages, the use of higher values of salinity for the preconditioning is allowed. If, in spite of this expedient, the voltage required remains too high, shorter sections of the insulator may be separately preconditioned using adequate procedures to avoid overstressing of the internal insulation, if any (e.g. in the case of arresters or bushings).

## 5.6 Withstand test

The object of this test is to confirm the specified withstand salinity at the specified test voltage.

The test shall start when the test insulator and the chamber conditions fulfil the requirements given in 5.4 and after preconditioning the insulator according to 5.5.

A series of individual tests shall be performed on the insulator at the specified test voltage, using a salt solution having the specified salinity in accordance with 5.2. Unless flashover occurs earlier, the duration of each individual test shall be 1 h. The insulator shall be carefully washed with tap water before each subsequent individual test.

## 5.7 Acceptance criteria for the withstand test

The specified characteristics of the insulator are confirmed if no flashover occurs during a series of three consecutive individual tests in accordance with the procedure in 5.6. If only one flashover occurs, a fourth test shall be performed and the insulator then passes the test if no further flashover occurs.

# 6 Solid layer method

## 6.1 General information

The solid layer test procedure simulates type A pollution (see IEC TS 60815-1) where a solid layer containing salts and inert materials builds up on the insulator surface. When wetted this layer becomes conductive.

Contrary to solid layer test method for a.c. voltage for d.c. voltage only the test procedure type "B" is considered due to the high scatter of the results obtained with tests carried out according to the type "A" procedure.

**Procedure B – wetting after energization**, where the test voltage is applied to a dry insulator before any wetting occurs. This simulates the most frequent situation for sites with solid layer contamination as may occur in rural, industrial and desert conditions.

The degree of pollution in a test is defined by Salt Deposit Density (SDD), which is expressed in mg of salt (NaCl) per cm<sup>2</sup> of the specified surface of the test specimen.

For this procedure, the wetting process is started after the application of constant test voltage to the insulator with the layer dry and it lasts with a constant steam input rate to the end of individual test.

Based on experience with solid layer pollution tests this procedure is recommended for testing of insulators for highest system voltage of 600 kV and above. Some supplementary information is given in Annex E.

## 6.2 Main characteristics of inert materials

Kaolin shall be preferred as the inert material. Other inert material as Tonoko can be used if it is agreed between manufacturer and purchaser, but test results are not directly comparable and the different suspension concentrations may be needed to attain the required NSDD range [1].

Ranges of values for the main characteristics of the inert materials are given in Table 2.

**Table 2 – Main characteristics of the inert materials used in solid layer suspensions**

Type of inert material	Weight composition %				Granulometry (cumulative distribution)			Volume conductivity $\sigma_{20}$ S/m
	SiO <sub>2</sub>	Al <sub>2</sub> O <sub>3</sub>	Fe <sub>2</sub> O <sub>3</sub>	H <sub>2</sub> O	μm			
					16 %	50 %	85 %	
Kaolin	40 to 50	30 to 40	0,3 to 2	7 to 14	0,5 to 2	2 to 8	8 to 25	0,0015 to 0,02
Tonoko	60 to 70	10 to 20	4 to 8	-	1 to 3	6 to 10	15 to 30	0,002 to 0,01

NOTE 1 Granulometry distribution gives the values of the hole diameter of a sieve in μm through which one of the quoted percentages of the total mass of particles passes. The values in Table 2 were determined by measurement using the laser light scattering technique. Other methods may provide somewhat different values.

NOTE 2 Volume conductivity for the characterization of inert material is determined with the use of demineralised water.

## 6.3 Composition of the contaminating suspension

- 40 g Kaolin (or Tonoko) (see 6.2);
- 1 000 g tap water;
- a suitable amount of NaCl of commercial purity.

NOTE The quantity of Kaolin (or Tonoko) above corresponds very roughly to an NSDD of about 0,1 mg/cm<sup>2</sup>.

When the volume conductivity of tap water is higher than 0,1 S/m, demineralized water shall be used.

To achieve the reference degree of pollution on the insulator under test, with the prescribed tolerance of ±15 %, an appropriate value of volume conductivity of the prepared suspension is to be determined by submitting the insulator itself (or part of it) to preliminary contamination trials. The desired volume conductivity is reached by adjusting the amount of salt in the suspension.

As an approximate guide to start the trials, Table 3 gives an approximate correspondence between the reference degree of pollution on the insulator and the volume conductivity of the suspension at a temperature of 20 °C, in the case of standard cap and pin insulators

contaminated in a vertical position in normal ambient conditions. The volume conductivity required for other insulators can vary from the values given in Table 3.

**Table 3 – Kaolin (or Tonoko) composition: approximate correspondence between the reference degrees of pollution on the insulator and the volume conductivity of the suspension at a temperature of 20 °C**

Reference degrees of pollution for Kaolin (or Tonoko) composition		Volume conductivity of the suspension
Salt deposit density <i>SDD</i> mg/cm <sup>2</sup>	Layer conductivity <i>K</i> <sub>20</sub> μS	
0,012	-	0,5
0,018	-	0,7
0,025	3	1
0,035	4,2	1,4
0,05	5,5	2
0,07	8	2,8
0,1	11	4
0,14	14,5	5,6
0,2	20	8
0,28	27	11,2
0,4	37	16

#### 6.4 Application of the pollution layer

The suspension prepared using the composition described in 6.3 shall be applied by spraying, flow-on or brushing on the dry insulator, previously cleaned as recommended in 4.3.2, to obtain a reasonably uniform layer. Alternatively the insulator may be dipped in the suspension, provided its size allows this operation.

The layer shall be left to dry prior to the submission of the insulator to the test. More details are given in Clause C.2.

If after the contaminating operation a blotched layer is observed on the insulator, its surface shall be washed and cleaned again according to 4.3.2. Then one or more further contaminations shall be performed, each followed by the relevant washing, until a continuous layer is achieved on the insulator. At this time tests can start on it. Experience has shown that, in general, a few repeated operations are sufficient to prepare the insulator surface in a satisfactory manner.

The artificial pollution layer may be applied on the insulator surface by spraying the prepared suspension through one or two nozzles of a commercial type spray gun. The direction of the spray nozzles is adjusted to ensure a reasonably uniform layer on the whole insulator surface. A distance of about 200 mm to 400 mm between the spray nozzle outlet and the rim of the insulator shed has been found satisfactory. It is desirable to keep the suspension stirred.

The required degree of pollution on the insulator may be obtained by repeated applications.

When dipping the insulator, the suspension shall be well stirred and the insulator may be turned to achieve uniformity in the layer.



The coating time can be reduced by preheating the insulator. In this case the whole insulator shall be in thermal equilibrium with the air in the test chamber at the start of the test. The coating time can be reduced also by drying the layer between successive applications.

NOTE 1 The practice of flooding the prepared suspension over the insulator surface until it is flowing-on ("flow-on" technique) is particularly suitable for large or long insulators.

The layer shall be as uniform as possible (see Clause C.5).

NOTE 2 In the case of cap-and-pin type insulators a uniform layer can be obtained by more careful dipping using a procedure described as follows: The insulator is contaminated before its assembly in the test chamber. If the insulator consists of several units in series, each of them can be dipped separately and then be kept with its axis vertical for the duration of dripping of the contaminant up to the complete drying of the layer.

NOTE 3 In the case of long insulators, a reasonable uniformity of the layer can be reached by rotating the insulator while drying.

NOTE 4 The uniformity of the wet layer can be checked with a probe (see Annex A).

## 6.5 Determination of the degree of pollution of the test insulator

The degree of pollution of the test insulator expressed in terms of salt deposit density SDD is determined either on the tested insulators or on an identical insulator contaminated in the same way as follows.

After the contamination of the insulator (or part of it) chosen for SDD measurement, drops at the rims shall be removed carefully before they have dried.

Then the deposit is removed and carefully collected from the surface of the insulator (or a part of it). The whole surface of this insulator or upper and lower surfaces separately, are cleaned for this purpose excluding metal parts and assembling materials. More details are given in Clause C.8.

When only one insulator is available for the test, measurement of SDD is made on a few sheds. The surface which was cleaned for the measurement shall be re-contaminated.

The collected deposit is then dissolved in a known quantity of water, preferably deionized water. The resulting suspension is stirred for at least 2 min before the measurement of its volume conductivity  $\sigma_{\theta}$  (S/m) and the temperature  $\theta$  (°C). Then the value  $\sigma_{20}$  is obtained from  $\sigma_{\theta}$  by the relationship given in 5.2.

The salinity  $S_a$  (kg/m<sup>3</sup>) of the suspension is determined, when  $\sigma_{20}$  is within the range (0,004 to 0,4) S/m, by the following formula:

$$S_a = (5,7 \times \sigma_{20})^{1,03}$$

The salt deposit density SDD (mg/cm<sup>2</sup>) is then obtained by the following formula:

$$\text{SDD} = \frac{S_a \cdot V}{A}$$

where:

$V$  is the volume of the suspension (cm<sup>3</sup>)

$A$  is the area of the cleaned surface (cm<sup>2</sup>)

## 6.6 Test procedure

The insulator is prepared for the test according to 6.4 and placed in its test position with the pollution layer still dry.

Steam fog shall be used for wetting the layer.

The test object shall be wetted by means of fog generators which provide a uniform fog distribution around and over the whole length of the test object. The temperature of the test object at the beginning of the wetting shall be within 2 K of the ambient temperature in the test chamber.

NOTE The steam can be generated by different methods, e.g boilers inside the test chamber or steam generator outside the test chamber with distribution inside the test chamber by suitable tubes with holes

The fog generation in the test chamber shall be maintained until the end of the individual test at a constant steady rate of flow.

The fog generation shall be under the test object as close as possible to the floor level. In any case they shall be at least 1 m away from the test object and their flow shall not be directed towards it (see also Clause C.6).

A plastic tent surrounding the test object may be used to limit the volume of the test chamber without influencing, however, the pattern of the fog development around the insulator.

NOTE If a plastic tent is used, it can be useful to check the wetting efficiency by dummy insulator (see Clause C.5)

The steam input rate in the chamber shall be zero until the test voltage is applied and maintained constant thereafter. At normal ambient temperature, the nominal steam input rate of  $(0,05 \pm 0,01)$  kg/h per cubic metre of the test chamber volume normally provides the required wetting rate. In cases of very low or high outdoor temperature, especially with poor thermal insulation of the chamber, high altitude, or the presence of turbulence in the chamber, a direct check of the wetting action of the fog may be required as described in Clause C.4 and according to the checking results the necessary steam input rate may be different.

NOTE 1 For the determination of the steam rate, one of the following methods can be used:

- power measurements for steam fog generation;
- measurement of the amount of water used for steam generation in an individual test.

NOTE 2 The wetting action of the fog will be affected by the absolute humidity and condensation on the walls.

For very large test objects uniform wetting of the layer may be difficult to achieve. In such cases the procedure described in Clause C.5 may be used to check fog uniformity.

The test voltage is maintained until flashover occurs. Otherwise it is maintained for 100 min from the start of the test or until the risk of flashover is judged negligible by measurement of the leakage current or other techniques. More detailed information is given in Clause C.7.

The pollution layer can be used only once.

## **6.7 Withstand test and acceptance criteria**

The object of this test is to confirm the specified withstand degree of pollution at the specified test voltage. The specified characteristics of the insulators are confirmed if no flashover occurs during three consecutive individual tests performed in accordance with 6.6. If only one flashover occurs, a fourth test shall be performed and the insulator then passes the test if no further flashover occurs.

## Annex A (informative)

### Method for checking the uniformity of the layer

The device for checking the uniformity of the wet layer on an insulator surface basically consists of a probe and a meter. As an indication a possible arrangement of such a device is described as follows:

- *Probe* (Figure A.1)  
Two spherical stainless steel electrodes, 5 mm diameter and 14 mm between centres, overhanging from the probe shall be pressed against the insulator surface. A constant surface pressure is obtained by means of a spring mechanism developing a force of about 9 N.
- *Meter* (Figure A.2)  
A voltage source stabilized by a Zener-diode at 6,8 V supplies the current across the electrodes and the surface between them. The measuring instrument with a full scale deflection at 50  $\mu\text{A}$  is protected by a diode in parallel.

Measurements shall be carried out at different points of the insulator surface. The polarization effect shall be taken into account by a momentary operation of the meter push-button.

The uniformity of the layer is deemed acceptable when the difference between each of the measurements and their average, as a percentage of the average value, does not exceed the limits  $\pm 30\%$ .

*Dimensions in millimetres*

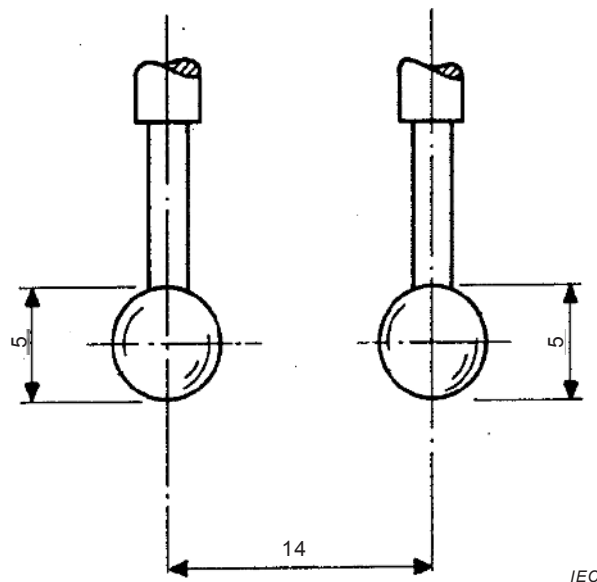
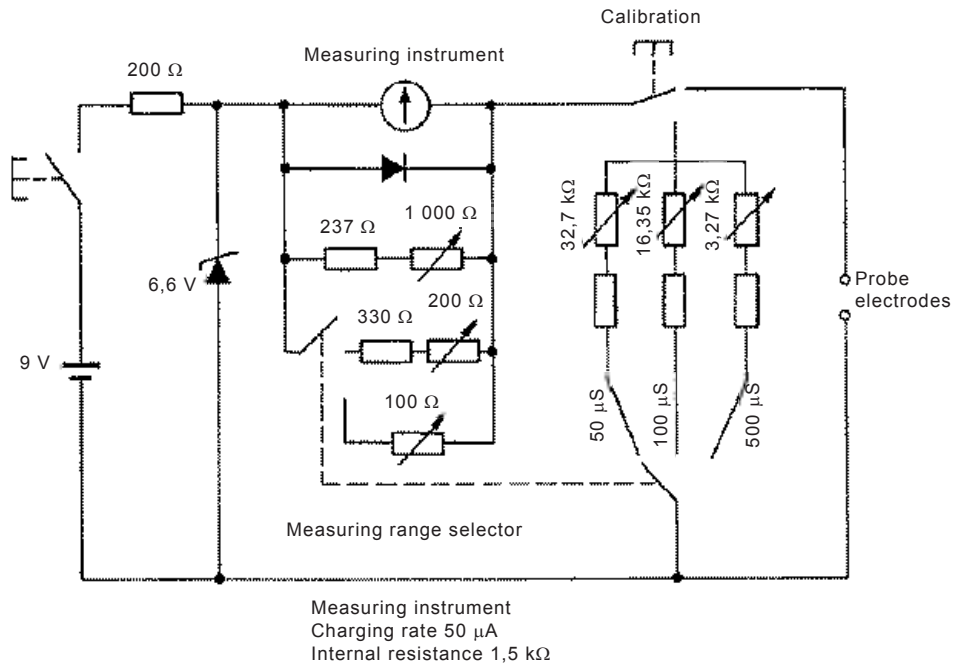

Figure A.1 – Arrangement of the probe electrodes



IEC

Figure A.2 – Circuit diagram of the meter

## **Annex B** (informative)

### **Determination of the withstand characteristics of insulators**

#### **B.1 General**

Clauses 5 and 6 deal with the verification of the specified withstand degree of pollution, at the specified test voltage. In addition, however, the characteristics of an insulator can be determined over a range of voltage, or, in other words, over a range of specific creepage distances of the insulator itself. To do this, the maximum withstand degree of pollution is measured at different voltage levels or the maximum withstand voltage is determined at different degrees of pollution values. Examples of procedures for such evaluations are described below (see Clauses B.2 and B.3).

Directions for checking the laboratory equipment for artificial pollution tests, when requested, are given in Annex E.

#### **B.2 Determination of the maximum withstand degree of pollution at a given test voltage**

The insulator shall be subjected to several tests at a given test voltage and at different degrees of pollution among those listed in 5.2 and 6.3. The tests shall be performed according to the test procedure of 5.6 or 6.6. The tests can be carried out in any sequence provided that:

- a) when the total number of individual tests ending with flashover at any degree of pollution reaches two, no further tests shall be carried out at the same or higher degree of pollution;
- b) when the total number of individual tests resulting in withstand reaches three, no further tests shall be carried out at the same or lower degree of pollution.

Should the individual tests at any degree of pollution lead to three tests resulting in withstand, the degree of pollution used can be declared to be the maximum withstand degree of pollution at the test voltage, provided that the next higher degree of pollution according to 5.2 or 6.3 leads to two individual tests, ending with flashover.

In the case of salt fog tests, the preconditioning process (see 5.5) shall be performed on the insulator before the determination of the maximum withstand salinity.

If four withstands occur in four individual tests at 224 kg/m<sup>3</sup> salinity, the maximum withstand salinity shall be assumed as being equal to or greater than 224 kg/m<sup>3</sup>. If one flashover and three withstands occur in four individual tests at 224 kg/m<sup>3</sup> salinity, this salinity shall be considered as the maximum withstand salinity.

#### **B.3 Determination of the maximum withstand voltage at a given degree of pollution**

A series of individual tests shall be carried out on insulators having a given degree of pollution. Each test shall be carried out at any one of a series of voltage levels, each of which shall be about 1,05 times the next lower value. The test shall be performed according to the test procedure of 5.6 or 6.6. The tests can be carried out in any sequence provided that:

- a) when the total number of individual tests ending with flashover at any voltage level reaches two, no further tests shall be carried out at the same or higher voltage level;

- b) when the total number of individual tests resulting in withstand at any voltage level reaches three, no further tests shall be carried out at the same or lower voltage level.

Should the individual tests, at any voltage level, result in three withstands, the voltage used can be declared to be the maximum withstand voltage at that degree of pollution, provided that the next higher voltage level leads to two individual tests ending with flashover.

In case of salt-fog tests, the preconditioning process (see 5.5) shall be performed on the insulator before the determination of the maximum withstand voltage.

#### **B.4 Determination of the 50 % withstand voltage at a given degree of pollution**

The insulator shall be subjected to at least ten "useful" tests at the given degree of pollution. The test shall be made in accordance with 5.6 or 6.6. The applied voltage level in each test shall be varied according to the up-and-down method. The voltage step shall be not more than 10 % of the expected 50 % withstand voltage.

The first "useful" test shall be selected as being the first one that yields a result different from the preceding test: only this test and at least nine following tests shall be taken as useful tests to be considered to determine the 50 % withstand voltage.

The calculation of the 50 % withstand voltage shall be made using the following formula:

$$U_{50\%} = \frac{\sum(n_i \times U_i)}{N}$$

where:

$U_i$  is an applied voltage level

$n_i$  is the number of groups of tests carried out at the same applied voltage level  $U_i$

$N$  is the number of useful tests

More details on the up-and-down method and processing of the relevant results are found in IEC 60060-1.

Alternatively, the method of maximum likelihood can be used to obtain  $U_{50\%}$ . More information about this method will be found in the relevant literature.

## **Annex C** (informative)

### **Additional recommendations concerning the solid layer method procedures**

#### **C.1 General**

The additional recommendations given below go more deeply into the practices of the solid layer methods. They provide criteria for auxiliary controls during the tests and help users who are not yet sufficiently expert in this field from obtaining inaccurate results.

#### **C.2 Contamination practice**

When the spraying or "flow-on" practice is used, the operation can be performed on the insulator placed in the chamber in its test position. When the dipping practice is used, the insulator shall be contaminated before its erection in the test chamber. If the insulator consists of several units in series, each of them shall be dipped separately and then be kept with its axis vertical for the duration of dripping of the contaminant and until the layer is completely dry.

If, after the contaminating operation, a blotched layer is observed on the insulator, its surface shall be washed and cleaned again according to 4.3.2. Then one or more trial contaminations are performed, each followed by the relevant washing, until a continuous layer is obtained on the insulator. The tests may then be started. Experience has shown that, in general, it suffices to repeat the operation several times in order to have the insulator surface ready to be contaminated in a satisfactory way, without using any preconditioning process.

#### **C.3 Drying of the pollution layer**

Natural drying of the pollution layer on the insulator may be sufficient, provided that it lasts long enough (6 h to 8 h) while the relative humidity is kept below 70 %. Humidity values lower than this level allow shorter drying times. If hot air is used to accelerate the drying of the layer, the method for producing hot air shall not result in the deposition of material which affects either the wetting of the insulator surface or the degree of pollution. Finally the speed of the hot air flow should be controlled, in order to prevent the disturbance of any content of the pollution layer on the insulator.

#### **C.4 Checking the wetting action of the fog**

The test insulator, contaminated with the same suspension as that which will be used for the actual test, shall be placed in the location where it will be tested.

Instead of the test insulator, a dummy insulator, similarly polluted, preferably of a similar type can be used. In this case the dummy insulator shall be installed as close as possible to the position of the insulator to be tested, and at the same average height above the floor.

While the fog generators are working as in the actual test, the layer conductance of the wet layer of the test insulator shall be periodically measured according to the following procedure.

Each measurement of the layer conductance consists of applying to the insulator a voltage (0 to 100 Hz) not lower than 1 000 V per metre of overall creepage distance and measuring the current. The voltage must be applied for sufficient time to determine the values of voltage

and current and short enough time to avoid serious error due to heating or drying of the pollution layer. No discharge activity shall occur.

The increase of the layer conductance with time shall be monitored. The rise time  $T_c$  shall be  $15 \text{ min} \leq T_c \leq 70 \text{ min}$  (see Figure C.1). If it is not, repeated humidification with different steam input rates shall be carried out until  $T_c$  is within the specified limits. The steam input rate so determined shall be used in the actual tests.

NOTE 1 The limits for the rise time are based on experience from a.c. tests and have been confirmed by some d.c. tests.

NOTE 2 It is suggested that a monitor insulator be installed also in the actual test chamber in order to achieve information to be useful for a future revision of the test procedures.

### C.5 Checking fog uniformity for large or complex test objects

If the test object is large or complex (e.g. more than 3 m long or with several insulating parts submitted to voltage) it may be necessary to check that the fog density (and hence the wetting rate) is uniform at the different parts of the test object. Uneven wetting of the test object, notably if the live end is wetted while the rest is still relatively dry can lead to incorrect results.

Measurements are made near the test object itself or placed at positions corresponding to the position of the test object if it is not present. It is left up to the test laboratory to decide on suitable measurements, typical examples are:

- Conductance measurement on polluted dummy insulators (measured as described in Clause C.4)

The dummy insulators shall be placed at positions that fall within the following guidelines:

- Within 1 to 1.5 m lateral distance from the test object
  - For test objects up to 3 m in height, one measurement site is sufficient and shall be placed approximately at the middle of the test object. For test objects exceeding 3 m in height the number of measuring sites shall be increased to cover the full height of the test object. It is recommended that the maximum distance between two adjacent measuring sites does not exceed 3 m.
- Conductance measurement on sections of the polluted test object itself is performed using suitable electrodes, e.g. copper adhesive tape. The conductance of these sections is measured as described in Clause C.4. The location of the electrodes should be such, to guarantee the uniform wetting distribution along the test object. In the case of multiple parallel insulator configurations, there is no need for measurement on each insulator arm.

It is recommended to carry out the wetting rate check as described in Clause C.4 after any adjustments in order to ensure that the steam input rate is still correct.

### C.6 Fog input to the test chamber

The fog shall be produced by steam generated by boiling water in open tanks or by steam admitted at low velocity through large diameter spray nozzles. The fog input to the test chamber shall be allowed only after the steam generation has reached its steady rate. Therefore, when the steam is produced in tanks, these shall be kept covered until the water inside reaches the boiling point.

The insulator shall be positioned so that the visible fog surrounds it as uniformly as possible.

The temperature rise in the test chamber, measured at the height of the test object, shall not exceed 15 K by the end of the test.



### C.7 Duration of the withstand test

Present knowledge indicates that the flashover risk becomes negligible when the test object withstands the test voltage for 100 min from fog application. However, the risk of flashover can be directly evaluated by measurement of leakage current on the energized test object during the test. This leakage current normally reaches a peak and then decreases due to washing of the layer. The risk of flashover is considered negligible if 30 min have passed from the start of discharge activity, indicated by the leakage current measurements.

When flashover is judged improbable by measurement of the leakage current or other techniques, the test can be stopped and considered as a withstand.

### C.8 Evaluation of the reference salt deposit density (*SDD*)

The pollution layer shall be removed completely from the area of the insulator chosen to be sampled. At least three consecutive wipings of that area shall be performed. As an indication, 2 l to 4 l of de-ionized water per square metre of the surface to be sampled can be used for dissolving the collected deposit. The effectiveness of the removal operation can be checked by making measurements of the residual deposit.

It is suggested to verify that that the ratio between local measurements of *SDD* (on upper surface or on lower surface of sheds) and the *SDD* on the whole sampled area of the insulator lies between 0,7 and 1,3.

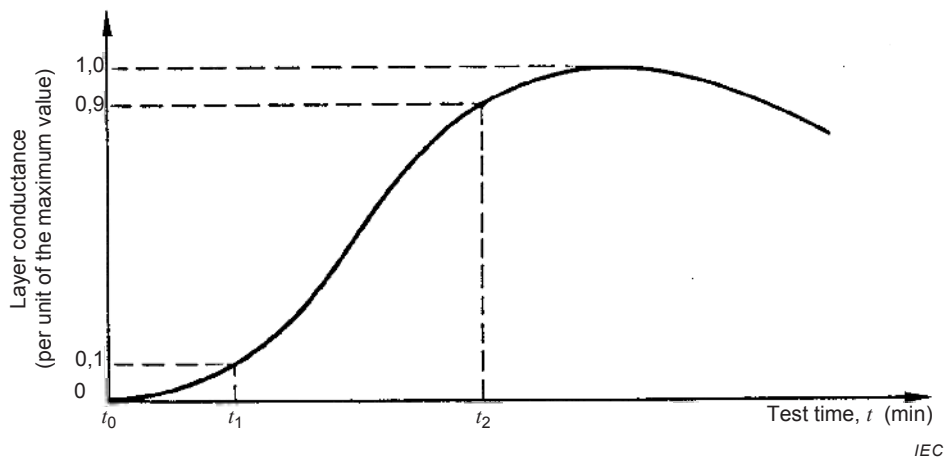

Figure C.1 – Determination of layer conductance and evaluation of its rise time  $T_c = t_2 - t_1$

## **Annex D** (informative)

### **Information to check equipment for artificial pollution tests**

To facilitate the adjustment of laboratory equipment for artificial pollution tests, values for the withstand characteristics of a few reference suspension insulators are given in Table D.1. These values, which are based for the time being on results from one laboratory located less than 1 000 m above sea level, were obtained according to the recommendations given in the present technical specification.

NOTE 1 Values to complete Table D.1 will be inserted after discussion of available results from different laboratories.

NOTE 2 The reference insulators given in Table D.1 are not to be seen as representative of their respective classes. Their choice does not imply in itself any judgement of merit or any assumption that they might have better performance than other similar types in tests or in operating conditions.

The choice of these insulators is based on the recommendations for the comparative inter-laboratory tests of the CIGRE/IEEE WG.

Laboratories starting artificial pollution tests or which are located at altitudes higher than 1 000 m above sea level, or which do not commonly use one of the above-mentioned test methods, may expect in the relevant results some variation from the ranges of values given in Table D.1.

**Table D.1 – (Provisional)**

Withstand degree of pollution and values of 50 % withstand voltage ( $U_{50\%}$ ) for reference insulators in artificial pollution tests. Single arrangement in vertical position. Results were obtained with tests procedures as given in the present technical specification.

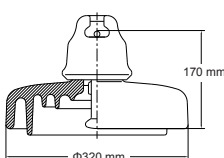
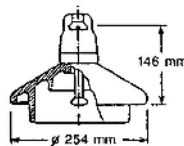
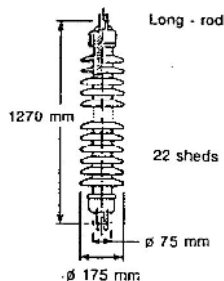
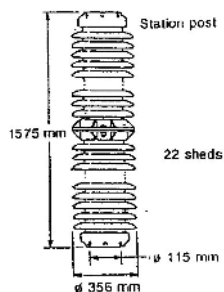
Insulator type and number of unit per string	Maximum withstand degree of pollution					$U_{50\%}$					
	Specified creepage distance	Applied voltage	kV unit	Salt fog method	Solid layer method	Salt fog method			Solid layer method <sup>a</sup>		
						Salinity	Creepage distance	$U_{50\%}$	SDD	Creepage distance	$U_{50\%}$
mm/kV	kV		kg/m <sup>3</sup>	mg/cm <sup>2</sup>	kg/m <sup>3</sup>	mm	kV	mg/cm <sup>2</sup>	mm	kV	
 <p>Antifog creepage distance: 570 mm Minimum: 5 units</p>								0,02	3 390	187	
 <p>Antifog creepage distance: 390 mm Minimum: 5 units</p>								0,02	2 730	144	
 <p>Long - rod 1270 mm 22 sheds 1 unit Creepage distance: 2 960 mm</p>								0,02	2 960	105	
 <p>Station post 1575 mm 22 sheds 1 unit Creepage distance: 3 353 mm</p>								0,02	3 353	102	

<sup>a</sup> These values are determined in only one laboratory. The reproducibility of the results is not established. The influence of the steam rate and of the absolute amount of steam depending on the size of testing chamber has still to be clarified.

## **Annex E**

### **(informative)**

## **Supplementary information on artificial pollution tests on insulators for voltage systems of $\pm 600$ kV and above (solid layer method procedure B)**

### **E.1 General**

In this annex, supplementary information, especially on testing facilities, wetting system, check of wetting action and steam input rate, is given with solid layer method–procedure B for artificial pollution tests on insulators for voltage systems above  $\pm 600$  kV.

### **E.2 Test chamber**

Recommended distances (in meters) of the live parts of test object from any earthed structure shall be greater than maximum phase to earth test voltage (in kV) divided by 200. The same distance shall be maintained between the live part of voltage supplier bushing and any part of test object.

### **E.3 Fog generator**

The fog can be generated in different ways, such as boiler(s) in the test chamber, horizontal and/or vertical nozzles fed by external steam generator, or combination of the above.

When nozzles are used they shall not be directly pointed at the test object.

### **E.4 Wetting action and uniformity of fog density**

Check of the wetting action and fog distribution uniformity according to Clauses C.4 and C.5 is recommended at least at each change of test configuration.

For large test objects there may be significant scatter in the test results, particularly at UHV test levels. To minimize this scatter precise control of all test parameters is necessary.

Test experience indicates that in a case of high temperature as in summer it may be necessary to increase the initial steam input rate for example up to  $0,080 \text{ kg/h/m}^3$  and to adjust the rate during the test. For example the initial rate could be kept for 10 to 20 minutes and then decreased for the rest of test duration.

### **E.5 Test of very large insulators**

When the main objective of the test is to obtain information about the pollution performance of insulators e.g. for comparison of different insulator types/profile (see 4.1), the test on relatively short insulator sets (e.g. arcing distance  $\geq 1,5$  m – if representative of the full set in terms of radial geometry and profile) may be sufficient.

## **Annex F** (informative)

### **Further investigation**

The following problems need further investigation:

- effectiveness of preconditioning with d.c. voltage in the case of salt fog procedure;
- influence of non-soluble materials on the test results in the case of solid layer procedure;
- influence of steam rate and actual d.c. electric field on wetting characteristics;
- application of atmospheric correction factors;
- salt fog test method for voltages greater than  $\pm 600$  kV.

## Bibliography

IEC 60507, *Artificial pollution tests on high-voltage ceramic and glass insulators to be used on a.c. systems*

- [1] Outdoor insulation in polluted conditions: Guidelines for selection and dimensioning. Part 2: The DC case. CIGRE Technical Brochure No. 518
-



# British Standards Institution (BSI)

BSI is the national body responsible for preparing British Standards and other standards-related publications, information and services.

BSI is incorporated by Royal Charter. British Standards and other standardization products are published by BSI Standards Limited.

## About us

We bring together business, industry, government, consumers, innovators and others to shape their combined experience and expertise into standards-based solutions.

The knowledge embodied in our standards has been carefully assembled in a dependable format and refined through our open consultation process. Organizations of all sizes and across all sectors choose standards to help them achieve their goals.

## Information on standards

We can provide you with the knowledge that your organization needs to succeed. Find out more about British Standards by visiting our website at [bsigroup.com/standards](http://bsigroup.com/standards) or contacting our Customer Services team or Knowledge Centre.

## Buying standards

You can buy and download PDF versions of BSI publications, including British and adopted European and international standards, through our website at [bsigroup.com/shop](http://bsigroup.com/shop), where hard copies can also be purchased.

If you need international and foreign standards from other Standards Development Organizations, hard copies can be ordered from our Customer Services team.

## Subscriptions

Our range of subscription services are designed to make using standards easier for you. For further information on our subscription products go to [bsigroup.com/subscriptions](http://bsigroup.com/subscriptions).

With **British Standards Online (BSOL)** you'll have instant access to over 55,000 British and adopted European and international standards from your desktop. It's available 24/7 and is refreshed daily so you'll always be up to date.

You can keep in touch with standards developments and receive substantial discounts on the purchase price of standards, both in single copy and subscription format, by becoming a **BSI Subscribing Member**.

**PLUS** is an updating service exclusive to BSI Subscribing Members. You will automatically receive the latest hard copy of your standards when they're revised or replaced.

To find out more about becoming a BSI Subscribing Member and the benefits of membership, please visit [bsigroup.com/shop](http://bsigroup.com/shop).

With a **Multi-User Network Licence (MUNL)** you are able to host standards publications on your intranet. Licences can cover as few or as many users as you wish. With updates supplied as soon as they're available, you can be sure your documentation is current. For further information, email [bsmusales@bsigroup.com](mailto:bsmusales@bsigroup.com).

## BSI Group Headquarters

389 Chiswick High Road London W4 4AL UK

## Revisions

Our British Standards and other publications are updated by amendment or revision.

We continually improve the quality of our products and services to benefit your business. If you find an inaccuracy or ambiguity within a British Standard or other BSI publication please inform the Knowledge Centre.

## Copyright

All the data, software and documentation set out in all British Standards and other BSI publications are the property of and copyrighted by BSI, or some person or entity that owns copyright in the information used (such as the international standardization bodies) and has formally licensed such information to BSI for commercial publication and use. Except as permitted under the Copyright, Designs and Patents Act 1988 no extract may be reproduced, stored in a retrieval system or transmitted in any form or by any means – electronic, photocopying, recording or otherwise – without prior written permission from BSI. Details and advice can be obtained from the Copyright & Licensing Department.

## Useful Contacts:

### Customer Services

**Tel:** +44 845 086 9001

**Email (orders):** [orders@bsigroup.com](mailto:orders@bsigroup.com)

**Email (enquiries):** [cservices@bsigroup.com](mailto:cservices@bsigroup.com)

### Subscriptions

**Tel:** +44 845 086 9001

**Email:** [subscriptions@bsigroup.com](mailto:subscriptions@bsigroup.com)

### Knowledge Centre

**Tel:** +44 20 8996 7004

**Email:** [knowledgecentre@bsigroup.com](mailto:knowledgecentre@bsigroup.com)

### Copyright & Licensing

**Tel:** +44 20 8996 7070

**Email:** [copyright@bsigroup.com](mailto:copyright@bsigroup.com)



...making excellence a habit.™