



BSI Standards Publication

Shunt capacitors for AC power systems having a rated voltage above 1 000 V

Part 3: Protection of shunt capacitors and shunt capacitor banks

National foreword

This Published Document is the UK implementation of IEC/TS 60871-3:2015.

The UK participation in its preparation was entrusted to Technical Committee PEL/33, Power capacitors.

A list of organizations represented on this committee can be obtained on request to its secretary.

This publication does not purport to include all the necessary provisions of a contract. Users are responsible for its correct application.

© The British Standards Institution 2015.

Published by BSI Standards Limited 2015

ISBN 978 0 580 85306 7

ICS 29.240.99; 31.060.70

Compliance with a British Standard cannot confer immunity from legal obligations.

This Published Document was published under the authority of the Standards Policy and Strategy Committee on 31 July 2015.

Amendments/corrigenda issued since publication

Date	Text affected
-------------	----------------------



TECHNICAL SPECIFICATION

**Shunt capacitors for AC power systems having a rated voltage above 1 000 V –
Part 3: Protection of shunt capacitors and shunt capacitor banks**

INTERNATIONAL
ELECTROTECHNICAL
COMMISSION

ICS 29.240.99; 31.060.70

ISBN 978-2-8322-2755-8

Warning! Make sure that you obtained this publication from an authorized distributor.

CONTENTS

FOREWORD	5
1 Scope	7
2 Normative references	7
3 Terms and definitions	7
4 Internal fuses	7
4.1 General	7
4.2 Fuse characteristics	8
4.2.1 Rated current.....	8
4.2.2 Rated discharge capability	8
4.2.3 Disconnecting capability	8
4.2.4 Voltage withstand capability after operation.....	8
4.3 Influence of capacitor element configuration on capacitor life.....	8
4.3.1 Capacitor with all elements connected in parallel.....	8
4.3.2 Capacitor with elements connected in series and parallel	8
5 External fuses	8
5.1 General	8
5.2 Fuse characteristics	9
5.2.1 Rated current.....	9
5.2.2 Rated voltage	9
5.2.3 Time-current characteristics	9
5.2.4 Discharge capability.....	10
5.3 Fuse types	10
5.3.1 General	10
5.3.2 Expulsion fuses	10
5.3.3 Current-limiting fuses.....	11
5.3.4 Combination current-limiting/expulsion fuses.....	11
5.4 Influence of capacitor bank configuration on fuse selection.....	11
5.4.1 Single series section grounded star and delta banks	11
5.4.2 Single series section ungrounded star banks.....	11
5.4.3 Multiple series section banks	11
5.5 Coordination with case rupture curves.....	11
6 Unbalance detection	12
6.1 Operation.....	12
6.2 Types of unbalance protection.....	12
6.2.1 Neutral current (Figure 3).....	12
6.2.2 Neutral voltage (Figure 4)	12
6.2.3 Current unbalance between neutrals (Figure 5)	13
6.2.4 Phase voltage unbalance (Figure 6)	13
6.2.5 Voltage difference (Figure 7).....	13
6.2.6 Current unbalance in bridge connection (Figure 8)	13
6.3 Current and voltage transformers	13
6.3.1 Current transformers.....	13
6.3.2 Voltage transformers.....	14
6.4 Relays and protection settings	14
6.5 Sensitivity	14
6.6 Initial unbalance.....	15

7	Overload current	15
7.1	Operation.....	15
7.2	Protective arrangement.....	15
7.3	Current transformers.....	15
7.4	Relays.....	15
7.5	Protective settings	16
8	Over and undervoltage	16
8.1	Operation.....	16
8.2	Overvoltage protection.....	16
8.3	Undervoltage protection	16
8.4	Reclosing.....	16
9	Other protection	17
9.1	Surge arresters.....	17
9.1.1	General	17
9.1.2	Operation	17
9.1.3	Lightning transients.....	17
9.1.4	Switching transients.....	17
9.1.5	Temporary overvoltages.....	17
9.1.6	Rated voltage	17
9.1.7	Energy absorption.....	18
9.2	Damping devices	18
9.2.1	Capacitor switching.....	18
9.2.2	Inrush currents	18
9.2.3	Voltage transients.....	19
9.2.4	Ratings.....	19
9.3	Synchronized switching.....	19
9.3.1	Operation	19
9.3.2	Breaker contacts delay.....	19
10	Safety	19
10.1	Discharging devices.....	19
10.1.1	General	19
10.1.2	Internal resistors.....	20
10.1.3	External discharge devices	20
10.1.4	Discharging after disconnection	20
10.2	Dead metallic parts	20
	Bibliography	25
	Figure 1 – Fuse types	10
	Figure 2 – Typical case rupture curves for approximately 30 000 cm ³ case volume	21
	Figure 3 – Star connection with the neutral grounded through a current transformer	21
	Figure 4 – Star connection with voltage transformer between neutral and ground	21
	Figure 5 – Star connection with ungrounded neutral and voltage transformers connected in an open delta	22
	Figure 6 – Double-star connection with ungrounded neutral	22
	Figure 7 – Star connection with grounded neutral and voltage transformers connected in differential measurement.....	22
	Figure 8 – Bridge connection	22

Figure 9 – Line overcurrent relays for capacitor bank, grounded22

Figure 10 – Line overcurrent relays for capacitor bank, ungrounded23

Table 1 – Melting currents for type-K (fast) fuse links, in amperes23

Table 2 – Melting currents for type-T (slow) fuse links, in amperes24

INTERNATIONAL ELECTROTECHNICAL COMMISSION

**SHUNT CAPACITORS FOR AC POWER SYSTEMS HAVING
A RATED VOLTAGE ABOVE 1 000 V –****Part 3: Protection of shunt capacitors and
shunt capacitor banks**

FOREWORD

- 1) The International Electrotechnical Commission (IEC) is a worldwide organization for standardization comprising all national electrotechnical committees (IEC National Committees). The object of IEC is to promote international co-operation on all questions concerning standardization in the electrical and electronic fields. To this end and in addition to other activities, IEC publishes International Standards, Technical Specifications, Technical Reports, Publicly Available Specifications (PAS) and Guides (hereafter referred to as “IEC Publication(s)”). Their preparation is entrusted to technical committees; any IEC National Committee interested in the subject dealt with may participate in this preparatory work. International, governmental and non-governmental organizations liaising with the IEC also participate in this preparation. IEC collaborates closely with the International Organization for Standardization (ISO) in accordance with conditions determined by agreement between the two organizations.
- 2) The formal decisions or agreements of IEC on technical matters express, as nearly as possible, an international consensus of opinion on the relevant subjects since each technical committee has representation from all interested IEC National Committees.
- 3) IEC Publications have the form of recommendations for international use and are accepted by IEC National Committees in that sense. While all reasonable efforts are made to ensure that the technical content of IEC Publications is accurate, IEC cannot be held responsible for the way in which they are used or for any misinterpretation by any end user.
- 4) In order to promote international uniformity, IEC National Committees undertake to apply IEC Publications transparently to the maximum extent possible in their national and regional publications. Any divergence between any IEC Publication and the corresponding national or regional publication shall be clearly indicated in the latter.
- 5) IEC itself does not provide any attestation of conformity. Independent certification bodies provide conformity assessment services and, in some areas, access to IEC marks of conformity. IEC is not responsible for any services carried out by independent certification bodies.
- 6) All users should ensure that they have the latest edition of this publication.
- 7) No liability shall attach to IEC or its directors, employees, servants or agents including individual experts and members of its technical committees and IEC National Committees for any personal injury, property damage or other damage of any nature whatsoever, whether direct or indirect, or for costs (including legal fees) and expenses arising out of the publication, use of, or reliance upon, this IEC Publication or any other IEC Publications.
- 8) Attention is drawn to the Normative references cited in this publication. Use of the referenced publications is indispensable for the correct application of this publication.
- 9) Attention is drawn to the possibility that some of the elements of this IEC Publication may be the subject of patent rights. IEC shall not be held responsible for identifying any or all such patent rights.

The main task of IEC technical committees is to prepare International Standards. In exceptional circumstances, a technical committee may propose the publication of a technical specification when

- the required support cannot be obtained for the publication of an International Standard, despite repeated efforts, or
- the subject is still under technical development or where, for any other reason, there is the future but no immediate possibility of an agreement on an International Standard.

International Standard IEC 60871-3, which is a technical specification, has been prepared by IEC technical committee 33: Power capacitors and their applications.

This second edition cancels and replaces the first edition published in 1996. This edition constitutes a technical revision.

This edition includes the following significant technical changes with respect to the previous edition:

- a) Clearer writing of formulas on energy limitation for expulsion fuses;
- b) Updated normative references and bibliography;
- c) A new clause for synchronized switching has been added.

The text of this technical specification is based on the following documents:

Enquiry draft	Report on voting
33/545/DTS	33/563/RVC

Full information on the voting for the approval of this technical specification can be found in the report on voting indicated in the above table.

This publication has been drafted in accordance with the ISO/IEC Directives, Part 2.

A list of all parts in the IEC 60871, published under the general title *Shunt capacitors for a.c. power systems having a rated voltage above 1 000 V*, can be found on the IEC website.

The committee has decided that the contents of this publication will remain unchanged until the stability date indicated on the IEC website under "<http://webstore.iec.ch>" in the data related to the specific publication. At this date, the publication will be

- transformed into an International standard,
- reconfirmed,
- withdrawn,
- replaced by a revised edition, or
- amended.

A bilingual version of this publication may be issued at a later date.

SHUNT CAPACITORS FOR AC POWER SYSTEMS HAVING A RATED VOLTAGE ABOVE 1 000 V –

Part 3: Protection of shunt capacitors and shunt capacitor banks

1 Scope

This part of IEC 60871, which is a technical specification, gives guidance on the protection of shunt capacitors and shunt capacitor banks. It applies to capacitors according to IEC 60871-1.

2 Normative references

The following documents, in whole or in part, are normatively referenced in this document and are indispensable for its application. For dated references, only the edition cited applies. For undated references, the latest edition of the referenced document (including any amendments) applies.

IEC 60549, *High-voltage fuses for the external protection of shunt capacitors*

IEC 60871-1, *Shunt capacitors for a.c. power systems having a rated voltage above 1 000 V – Part 1: General*

IEC 60871-4, *Shunt capacitors for AC power systems having a rated voltage above 1 000 V – Part 4: Internal fuses*

3 Terms and definitions

For the purposes of this document, the terms and definitions given in IEC 60549, IEC 60871-1 and IEC 60871-4 apply.

4 Internal fuses

4.1 General

Internal fuses for shunt capacitors are selective current-limiting fuses arranged inside a capacitor. As defined in IEC 60871-4, they are designed to isolate faulted capacitor elements or capacitor unit, to allow operation of the remaining parts of that capacitor unit and the bank in which the capacitor unit is connected.

The operation of an internal fuse is initiated by the breakdown of a capacitor element. The affected element is instantaneously disconnected by the operation of the element fuse without interruption in the operation of the capacitor.

The number of externally parallel connected capacitors and the available short-circuit current of the supply system should not affect the current-limiting of internal fuses.

It should be noted that internal fuses do not provide protection against a short circuit between internal connections or a short circuit between active parts and casing, both of which may lead to case rupture.

4.2 Fuse characteristics

4.2.1 Rated current

There is no definition or test method existing for element fuses.

Element fuses are, in general, designed for much higher currents than the maximum permissible element current. They are meant to disconnect only faulty elements. The faulty elements and their fuses are not intended to be replaced.

4.2.2 Rated discharge capability

IEC 60871-4 and IEC 60871-1 specify that the capacitor be subject to five undamped discharges from a d.c. charge level of $2,5 U_N$. For special applications, where inrush currents and/or peak voltages are limited, lower discharge requirements are applicable.

4.2.3 Disconnecting capability

Requirements and test procedures are given in IEC 60871-4. These tests verify that the fuse has a current-limiting action.

4.2.4 Voltage withstand capability after operation

Requirements and test procedures are given in IEC 60871-4.

4.3 Influence of capacitor element configuration on capacitor life

4.3.1 Capacitor with all elements connected in parallel

After the breakdown of an element, the respective fuse will melt in less than a millisecond owing to the discharge current from the parallel connected elements and capacitors and the power frequency current from the supply. The capacitor may, however, continue operating with a correspondingly reduced output.

If the capacitor is operated at a fixed bus voltage, no variation in operating voltage on the remaining healthy elements will occur.

4.3.2 Capacitor with elements connected in series and parallel

After the breakdown of an element, all parallel connected elements discharge their stored energy or part of it into the faulty element. The power frequency current is limited by the remaining healthy elements connected in series.

After the disconnection of the faulty element, the capacitor continues operating with a correspondingly reduced output. The remaining healthy elements of the group are then stressed with a voltage approximately $m \times n / [m(n - 1) + 1]$ times the initial voltage, where n is the number of parallel connected elements per group and m the number of series-connected sections per unit. In certain cases the voltage may be higher, for example due to neutral shift with an ungrounded star configuration.

5 External fuses

5.1 General

External fuses for shunt capacitors are defined in IEC 60549 as intended to clear faults inside a capacitor unit and to permit continued operation of the remaining parts of the bank in which the unit is connected. They will also clear an external capacitor bushing flashover.

The operation of an external fuse is generally determined by the power frequency fault current and by the discharge energy from capacitors connected in parallel with the faulty capacitor.

The initial breakdown is usually of an individual element within a capacitor. This invariably becomes a short circuit which removes all elements in parallel with it and eliminates one series section from the capacitor. Should the cause of the initial failure continue, failure of successive series sections (which see an increasing voltage with each series section removed) will occur. This causes an increase in the current through the capacitor to the point where the fuse operates removing the failed capacitor from the circuit.

It should be noted, particularly in the case of paper or paper/film dielectric capacitors, that the capacitor case may occasionally rupture in the event of failure. This occurs when the initial element failure has high resistance between the shorted electrodes due to the presence of paper and sustained arcing generates gas which swells the case to the point where it may rupture before the protecting fuse can disconnect the capacitor.

Capacitors with all-film dielectric have a lower incidence of case rupture because the film melts and generally allows a low resistance short between the electrodes. However, case rupture may still occur due to arcing when there is a broken internal connection and when there is excessive stored energy available in parallel capacitors and/or high power frequency fault current.

5.2 Fuse characteristics

5.2.1 Rated current

The rated current of the selected fuse should be consistent with the criteria used for the selection of a switch or circuit-breaker for the same bank. From the various national standards the minimum accepted rating is 1,35 times the rated capacitor current.

In a steady-state basis, there is no need for the fuse capability to exceed that for the switch or circuit-breaker. However, transient conditions such as currents associated with system or bank switching should be considered. It is common to use a fuse with a current rating of 1,65 times the rated capacitor current.

IEC 60549 specifies that the fuse rated current be at least 1,43 times the capacitor rating. This falls between the two values mentioned above of 1,35 and 1,65. For some banks, the fuse rating may be higher than 1,65 times the capacitor rated current to avoid spurious fuse operation due to switching transients and for mechanical reasons.

NOTE The continuous rating of the fuse is not necessarily its nameplate rating. For example, an expulsion fuse link with a rating much smaller than the rating of the fuse holder can carry 150 % of its nameplate rating on a continuous basis. It is extremely important that the actual current rating of the fuse link be known. Typically, fuse holders are available in two current ratings, one for up to 50 A and the other for up to 100 A, whereas fuse links used in these holders are rated from 5 A to 100 A. These holders also vary in voltage rating, e.g. up to 9 kV, 9 kV to 16 kV and 16 kV to 25 kV.

5.2.2 Rated voltage

The rated voltage of the fuse should be not less than 1,1 times the rated voltage of the capacitor with which it is associated in order to meet the requirements of IEC 60549.

5.2.3 Time-current characteristics

Time-current characteristics are available from most fuse manufacturers to assist in coordination.

This information is sometimes available in table form.

5.2.4 Discharge capability

The external fuse should be capable of withstanding inrush transients and currents due to external short circuits. IEC 60549 specifies tests to verify the I^2t to which the fuse may be subjected for 5 and 100 discharges.

5.3 Fuse types

5.3.1 General

The different types of fuse are indicated in Figure 1.

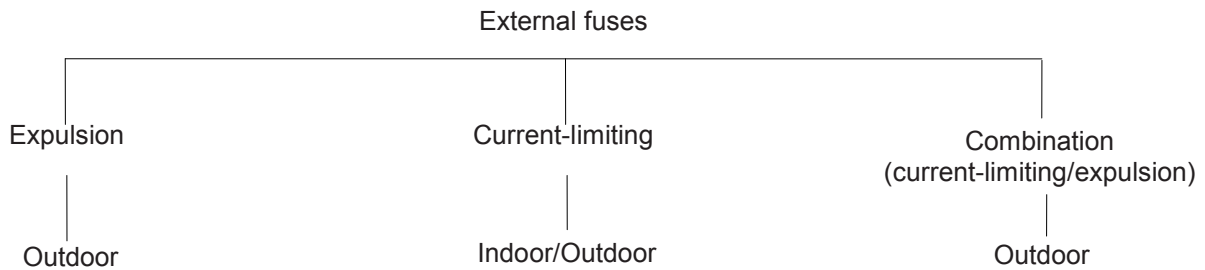

IEC

Figure 1 – Fuse types

5.3.2 Expulsion fuses

The following information on expulsion fuses should be noted:

- a) Expulsion fuses are normally used in outdoor applications due to noise and gases released during fuse operation.
- b) Expulsion fuses have limited power frequency fault current capability. Therefore consult with the fuse manufacturer when fault current at the fuse exceeds 1 800 A, or use current-limiting fuses.

Floating star-connected banks and those with multiple series sections minimize the importance of the power frequency interrupting capability of the fuse.

- c) Expulsion fuses have limited ability to clear against the discharge energy of capacitors connected in parallel with a shorted capacitor. Standard fuses are generally rated at 15 kJ or less; consult the fuse manufacturer.

Both fuse tubes and capacitor cases may rupture due to energy available in the event of a capacitor failure. The probability of case rupture in the event of capacitor failure is generally considered acceptable with all-film capacitors when the parallel energy has generally been limited to 15 kJ. This limit is calculated on the basis that the capacitor voltage is at 1,1 times the peak value of rated voltage (when higher power frequency overvoltages are anticipated, the parallel energy should be reduced accordingly). At rated voltage, this limit is equivalent to 4 650 kvar of parallel connected capacitors at 60 Hz and 3 900 kvar at 50 Hz. For all-paper and film/paper capacitors, the energy is typically limited to 10 kJ.

From energy in W.s. (J): $Energy = C \times (U_{rms})^2$

Substituting capacitance: $C (\mu F) = \frac{kvar \times 1000}{2\pi \times f_N \times U_N^2}$

It follows then that: $energy = 159 \times kvar/frequency$

- d) Expulsion fuse links are available in ANSI Type T and Type K (see bibliography). The difference in performance is in the time for melting of the link, as shown in Tables 1 and 2.

5.3.3 Current-limiting fuses

The following information on current-limiting fuses should be noted:

- a) Current-limiting fuses may be used for indoor and outdoor applications.
- b) Current-limiting fuses will limit the power frequency short-circuit current to less than the prospective value and will reduce the current to zero before the normal working frequency current zero.
- c) Generally, current-limiting fuses impose no upper limit on the parallel stored energy available to a shorted capacitor. However, some current-limiting fuses have a maximum limit for parallel energy. The fuse manufacturer should be consulted regarding the discharge energy interrupting rating.
- d) It should be noted that some fuses will not clear on power frequency current. The fuse manufacturer should be consulted regarding the interrupting rating for power frequency current.

5.3.4 Combination current-limiting/expulsion fuses

As the name implies, these fuses combine a totally enclosed current-limiting fuse with an expulsion fuse.

- a) As with expulsion fuses, combination fuses are normally used in outdoor applications due to noise and gases released during fuse operation.
- b) As with current-limiting fuses, combination fuses will limit the power frequency short-circuit current to less than the prospective value and will reduce the current to zero before the normal working frequency current zero.
- c) As with current-limiting fuses, combination fuses generally have no upper limit on the parallel stored energy available to a shorted capacitor. However, some combination fuses have a maximum limit for parallel energy. The fuse manufacturer should be consulted regarding the discharge energy interrupting rating.
- d) It should be noted that some fuses will not clear on power frequency current. The fuse manufacturer should be consulted regarding the interrupting rating for power frequency current.

5.4 Influence of capacitor bank configuration on fuse selection

5.4.1 Single series section grounded star and delta banks

Current-limiting or combination fuses are normally required because a shorted capacitor is subjected to high fault currents that may cause the fuse holder or capacitor case to rupture.

5.4.2 Single series section ungrounded star banks

The available energy from parallel connected capacitors will probably be the determining factor in selecting either expulsion or one of the current-limiting options.

5.4.3 Multiple series section banks

Available short-circuit current is not a factor in these banks since the multiple series sections will limit the fault current through a shorted capacitor. In large banks having many capacitors in parallel per series section, expulsion type fuses may often be used if the bank configuration is changed, e.g. to double star, to limit the parallel energy.

5.5 Coordination with case rupture curves

In addition to the considerations in fuse selection already dealt with, the fuse should coordinate with the rupture curves for the bank capacitor units.

These curves are available in some national standards and from manufacturers of capacitors. Figure 2 illustrates examples of these curves.

To minimize risk of case rupture, selected fuses should provide coordination in the "low probability" region. Refer to 5.3.2, 5.3.3 and 5.3.4 for comments on energy from capacitors connected in parallel.

6 Unbalance detection

6.1 Operation

Each time an internal capacitor element fails, a slight change of voltage distribution and current flow within the capacitor bank is encountered. The magnitude of these changes depends upon the number of failed elements and their location within the bank. If an externally fused capacitor is disconnected by its fuse, a larger voltage and current change is obtained than if single elements are disconnected by internal fuses.

By the use of various bank connections and relaying schemes, the voltage or current unbalance may be measured and utilized for protection. The main purpose of the unbalance protection is to give an alarm or to disconnect the entire capacitor bank when overvoltages across healthy capacitors, adjacent to a failed capacitor, are excessive. Normally not more than 10 % overvoltage should be allowed (overvoltage limit according to IEC 60871-1).

Another function of the unbalance protection is to remove the bank from service for a fault not isolated by a fuse or to protect banks that are not internally or externally fused. Unbalance protection is not a replacement for short-circuit protection.

6.2 Types of unbalance protection

6.2.1 Neutral current (Figure 3)

The capacitors are star-connected (grounded) with a current transformer between neutral and ground. An unbalance in the bank will cause current to flow from neutral to ground.

This protection scheme is sensitive to phase unbalances in the network and depends upon the system being effectively grounded. The settings should allow for normal variations and the sensitivity of the protection may therefore be impaired. Harmonic currents (3rd harmonic in particular) will pass through the current transformer; a filter may sometimes be necessary to avoid disturbances.

6.2.2 Neutral voltage (Figure 4)

The capacitors are star-connected (ungrounded) with a voltage transformer between neutral and ground. A voltage difference between neutral and ground will be measured at unbalance.

The sensitivity is relatively poor due to influence by phase unbalances and the scheme depends upon the system being effectively grounded. The settings should allow for normal variations and the sensitivity of the protection may therefore be impaired. The method is most suitable in combination with external fuses.

Voltage transformers used in this application should be rated for full system voltage. The neutral voltage will rise significantly during switching and the transformer may be saturated if not correctly rated. Resistive dividers and static relays may be used instead of voltage transformers to overcome the problems with saturation, transient overvoltages on switching and the high cost of a voltage transformer rated for full system voltage.

6.2.3 Current unbalance between neutrals (Figure 5)

The capacitors are arranged in two parallel stars (ungrounded) with a current transformer between the neutrals. The stars do not have to be equal in size. An unbalance in the bank will cause current to flow in the neutral.

This protection is not affected by unbalance in the network and it is not particularly sensitive to harmonics. The scheme may be used for both internal and external fuses. As the sensitivity performance is good the method is especially useful for internal fuses. The current transformer should be rated for full system voltage.

6.2.4 Phase voltage unbalance (Figure 6)

The capacitors are star-connected (ungrounded) and three line-to-neutral voltage transformers are used with their secondaries connected in open delta. An unbalance in the bank will cause a neutral shift voltage and thus an output signal from the open delta. These voltage transformers should have insulation rated for primary to ground and primary to secondary voltages.

Due to three-phase summation the output magnitude is higher than would be the case with the neutral to ground measurement (Figure 4). The sensitivity performance is therefore improved. The influence by phase unbalances is still a concern.

6.2.5 Voltage difference (Figure 7)

The capacitors are connected ungrounded or grounded star. The voltage shift of each phase midpoint (or close to midpoint) is measured relative to its line-to-neutral voltage by means of voltage transformers. Signals will be obtained separately from each phase where capacitor failures occur.

This method is suitable for large capacitor banks since the total bank will be divided into three separate protection zones. This may be of importance for overall sensitivity. The method is not influenced by phase voltage unbalance.

For very large capacitor banks a double star-connection may be used where comparisons are made between the midpoints of the two branches of each phase.

6.2.6 Current unbalance in bridge connection (Figure 8)

The capacitors in each phase are arranged in two branches with a current transformer connected between midpoints or close to midpoints of the two branches. Failures anywhere in the branches will cause an unbalance current to flow through the current transformer.

This method is suitable for large capacitor banks since the total bank will be divided into three separate protection zones. The method is not influenced by phase voltage unbalances. It may be used in delta- or star-connected banks with the neutral grounded or ungrounded.

6.3 Current and voltage transformers

6.3.1 Current transformers

Rated current is based on the calculated unbalance at different failure modes. Harmonic current should be considered in determining the rating. For internally fused capacitors the current may be very low and current transformers should be chosen accordingly.

For ungrounded banks the rated voltage should correspond to the system voltage. Lower ratings may be used if the banks are grounded.

The current transformer should be capable of withstanding currents during abnormal conditions such as short circuits. Such failures may lead to a high peak transient and high power frequency currents during the delay of the overcurrent protection. Switching current transient should also be taken into account. The current transformer may be protected at its primary by means of spark gaps or surge arresters.

The accuracy requirement is generally quite low. Class 10 P would normally be sufficient providing the measuring error of the current transformer at the protection setting current is less than 5 % (see IEC 60044-1). Should the maximum unbalance be much lower than the rated current of the current transformer, a better accuracy class is required.

6.3.2 Voltage transformers

The rated primary voltage of the voltage transformer should correspond to the calculated maximum unbalance.

For ungrounded banks the insulation class also applies to the voltage transformer. For grounded banks, voltage transformers with reduced insulation may be used.

When the primary winding forms a discharge path for the capacitor, the capability to withstand the discharge energy and peak current at disconnection from the line has to be considered.

Standard voltage transformers of accuracy class 0,5 are normally used (see IEC 60044-2). For connection schemes according to Figures 6 and 7, special attention should be paid to matching the voltage transformers in different phases.

6.4 Relays and protection settings

To avoid false operations due to switching or other transients, the unbalance relay should have a certain time delay. Typical delay-settings are about 0,1 s to 1 s; for external fuses, the coordination with fuses is of special importance. The relaying should also incorporate features for blocking of automatic reclosure if such a system is used.

Relays used for unbalance protection should normally have reduced sensitivity for frequencies other than the fundamental to prevent undesired operation and to simplify calculation of the relay setting.

When defining settings for the unbalance relay, one has to consider the overvoltage limit (10 %) for adjacent capacitors, i.e. alarm for overvoltages less than 10 %, trip when in excess of 10 %. For internally fused capacitors there may be different restrictions on voltage rise across parallel non-failed internal elements.

Depending on bank size, one or more fuses may be allowed to operate before an alarm is initiated. The protective relaying should trip the bank once the overvoltage limit is exceeded.

6.5 Sensitivity

The sensitivity of the protection depends upon the size of the capacitor bank or that part of the bank which is incorporated in one particular protection zone. For large banks a method that allows one separate relay (in rare cases even more) per phase is necessary.

When defining the number of relays based on sensitivity requirements, the influence of factors such as temperature differences within the bank should be considered.

Sensitivity analysis, i.e. the relation between number of failed elements, fuses and current or voltage outputs, is usually made by the capacitor manufacturer. Higher sensitivity is generally

needed with internally fused than with externally fused capacitors. Special computer programs are often available for sensitivity analysis.

6.6 Initial unbalance

Due to normal capacitance variation between capacitors, an initial unbalance may exist in a bank. This unbalance should be limited to a magnitude that allows for a clear definition of the criteria for relay operation and should normally not exceed 10 % of the relay setting.

As an alternative to initial balancing of capacitors, the unbalance may be compensated by means of suitable relays.

7 Overload current

7.1 Operation

Excessive capacitor currents may be obtained in connection with system voltage disturbances, harmonics and short-circuit failures. To protect the capacitors, current transformers with associated relays are used to detect current overloads and provide tripping operation of the bank.

As protection for short-circuit currents due to line-to-line and line-to-ground faults in moderately sized banks, power fuses may also be used.

7.2 Protective arrangement

For effectively grounded banks, the protection is normally arranged with a current transformer and its relay in each phase (Figure 9). If the bank is ungrounded, protection in two of the three phases is sufficient (Figure 10).

For smaller banks (typically less than 10 Mvar) without switched parallel sections, where the inrush transients are of short duration, a common relay for overload protection and short-circuit protection may be used. The setting will be an immediate trip at a relatively low current magnitude.

The current transients obtained with larger single banks, or when parallel banks are switched, lead to separate overload and short-circuit protection being required. The current settings are considerably higher for the short-circuit protection to avoid false operations at switching.

In the case of separate short-circuit protection, and if the bank is ungrounded, the current for line-to-line faults may not be sufficient to obtain instantaneous protection of the bank. However, the unbalance protection will always detect this kind of failure within a reasonable time delay.

7.3 Current transformers

Current transformers for overload protection should have a rated primary of at least 1,4 times rated current of the bank. Standard accuracy classes 5 P and 10 P would normally be sufficient for this application (see IEC 60044-1).

If a common current transformer is used for both metering and protection purposes, it will have two secondary windings, one for measuring devices and the other for relays.

7.4 Relays

The accuracy of the relays used for overload protection should be valid within the frequency range 50 Hz to 1 000 Hz. The resetting ratio should be at least 95 %; this ratio defines the

load level below the protection setting at which the relay is reset if the load decreases during the delayed functioning time.

7.5 Protective settings

For small banks (typically less than 10 Mvar) with common overload and short-circuit protection, the relay settings are normally in the range of 1,3 and 1,4 times rated current. The operation delay is set for a few cycles (maximum of 10 cycles).

For banks with separate overload and short-circuit protection, the overload protection is normally set in the range of 1,3 and 1,4 times rated current. The operation delay is set long enough to avoid false trips during switching. The short-circuit protection is set above $3 I_N$ and a few cycles delay. These settings have to be chosen with special attention to the inrush currents.

8 Over and undervoltage

8.1 Operation

For modern power capacitors, voltage withstand is often the decisive factor rather than thermal limitation. It may therefore be necessary to use overvoltage protection to complement the conventional overload protection based on current measurement.

Overvoltage protection may be arranged by means of peak value sensitive voltage relays with inverse voltage-time characteristics. Current relays with integrating functions to obtain the instantaneous peak voltage may also be used.

The voltage protection relay is also used to accomplish undervoltage protection and interlocking functions at reclosing.

Typically the voltage source for this protection system is derived from voltage transformers connected on the bus side of the capacitor switch. It should not be derived from voltage transformers connected line-to-earth on the capacitor side of the switch.

8.2 Overvoltage protection

Protection against overvoltage should take into account levels according to IEC 60871-1 and the particular application.

If the harmonic content is high, a special relay that measures the peak voltage should be used. To avoid undesired relay operations, the resetting ratio should be as high as possible.

8.3 Undervoltage protection

If the voltage is zero or abnormally low (e.g. $0,8 U_N$), the circuit-breaker of the capacitor bank should be opened and interlocked until the voltage returns to normal level. This is because upon re-energization the magnetization inrush current of power transformers contains a lot of harmonics and the capacitor may be in resonance with the network at one of these frequencies.

The circuit-breakers of power transformers and capacitor banks may also be coordinated to avoid these overvoltages and surge currents.

8.4 Reclosing

If a capacitor bank is not provided with discharge reactors (most usual case), reconnection of the bank after disconnection from the network should be delayed for the period defined by the

manufacturer, usually 3 min to 10 min. Before reconnection, the residual voltage should be less than $0,1 U_N$.

9 Other protection

9.1 Surge arresters

9.1.1 General

The guidelines below are applicable mainly to surge arresters of metal oxide varistor (MOV) types (see IEC 60099-4).

9.1.2 Operation

The purpose of the surge arresters is to limit possible overvoltages to levels not excessive to the protected equipment. The MOV arrester has a non-linear resistance that decreases several orders of magnitude when the voltage reaches a certain level. This limits the instantaneous voltage to a desired protective level.

9.1.3 Lightning transients

Surge arresters are traditionally used in power systems connected phase-ground and/or neutral-ground. Their purpose is mainly to protect against lightning surges, and the evaluation of necessary arrester performance is based on lightning peak current and system characteristics such as line impedance, line insulation level, etc. Surge arresters are not mainly intended for capacitor protection as a capacitor bank itself reduces transient voltages caused by lightning surges.

9.1.4 Switching transients

If circuit-breakers restrike or if misfiring failures occur in thyristor controlled systems, capacitors may experience severe overvoltages. In this case, arrester protection will be beneficial.

If the risk of restriking at switching is to be considered, a thorough investigation of voltage conditions and arrester capability should be carried out before selecting the components.

9.1.5 Temporary overvoltages

Capacitor banks exposed to temporary overvoltages of power frequency (and harmonics) may be protected by connection of arresters directly in parallel to each capacitor branch.

Temporary overvoltages may be caused by single-phase ground faults or switching in oscillations in low order tuned filters. They are characterized by fairly long duration (number of cycles). Generally detailed evaluation of dynamic voltages and energy loading of the arrester components should be carried out in these cases.

Data on permissible temporary overvoltages versus time for MOVs are given by the suppliers.

9.1.6 Rated voltage

The rated voltage of an arrester is used as a reference parameter to correlate operating and protective characteristics. It is defined as the level where a certain current flows through the arrester; this condition is usually permitted for durations in the order of minutes only.

The choice of the arrester rating is a compromise between protective level and temporary overvoltage capability. By increasing the rated voltage of the arrester, the probability to withstand overvoltage is increased, but the margin of protection is reduced.

Normally the continuous operating voltage across the equipment should not exceed 80 % of the rated voltage for a MOV arrester. Duration and frequency of the overvoltages may require the continuous operating voltage to be less than 80 % of the arrester rating.

9.1.7 Energy absorption

For proper selection of MOV arresters, the maximum energy developed during a discharge should be checked. For lightning duties, the evaluation is directly based on estimates on lightning charges and arrester voltage characteristics.

For switching and temporary overvoltage conditions, a more detailed evaluation of arrester energy development should be carried out. The energy absorption capability is usually specified by the supplier in terms of kilojoules per kilovolt of rating.

9.2 Damping devices

9.2.1 Capacitor switching

Damping devices, reactors and/or resistors, connected in series with a capacitor branch, are sometimes used for limiting the magnitude of switching transients. The transient phenomena at energization of a capacitor bank are characterized by a very high inrush current through the capacitor and a transient overvoltage with a magnitude up to two times rated voltage.

9.2.2 Inrush currents

The inrush currents may affect performance of the capacitor or the switching device. Capacitors may withstand current surges up to 100 times rated current, but the circuit-breakers are often limited to lower values.

The reactance of current-limiting reactors is normally less than 1 % of the bank impedance.

The maximum inrush peak current when switching a bank to the power supply may be calculated as shown in IEC 60871-1:

$$\hat{i}_s \approx I_N \sqrt{\frac{2S}{Q}}$$

where

\hat{i}_s is the peak inrush bank current, in amperes;

I_N is the rated capacitor bank current (r.m.s.), in amperes;

S is the short-circuit power (MVA) at the point where the capacitor is to be connected;

Q is the output of the bank, in megavars.

For calculating peak current when switching parallel banks the following formula may be used:

$$i_s = \frac{U\sqrt{2}}{\sqrt{X_C X_L}} \text{ where } X_C = 3U^2 \left(\frac{1}{Q_1} + \frac{1}{Q_2} \right) \times 10^{-6}$$

where

\hat{i}_s is the peak inrush bank current, in amperes;

U is the phase-to-earth voltage, in volts (r.m.s.);

X_C is the series-connected capacitive reactance per phase, in ohms;

X_L is the inductive reactance per phase between the banks, in ohms;

Q_1 is the output of the bank to be switched in, in megavars;

Q_2 is the sum of the output(s) of the bank(s) already energized, in megavars.

9.2.3 Voltage transients

Adequately selected series reactors may reduce the magnitude of transient overvoltages to acceptable levels. Other means for damping of transients are a combination of resistors and reactors or damping resistors only.

9.2.4 Ratings

Besides the desired inductance value, the continuous current load (r.m.s.) as well as maximum transient peak current should be specified for the damping reactor.

For continuous rating the maximum permissible current for the capacitor should be taken into account. According to IEC 60871-1 this maximum is 1,3 to 1,5 times the rated capacitor current.

9.3 Synchronized switching

9.3.1 Operation

Normal switching of a capacitor bank may cause severe transients. Energizing a discharged capacitor is similar to a momentary short circuit and it results in voltage and current transients that may cause problems. Controlling the circuit breaker to energize a capacitive load at zero voltage across the contacts will eliminate harmful transients.

Reduction of switching transients will reduce stresses in the system and its components. In addition, the circuit breaker itself will experience less energization currents, which will extend its service life. For capacitor banks the number of load switching operations can therefore be significantly increased before scheduled overhaul is required.

9.3.2 Breaker contacts delay

The magnitude of the transients depends on the point-on-wave where closing (or opening) of the circuit breaker contacts occur. The commands to the circuit breaker are delayed in such a way that making or contact separation will occur at the optimum time instant related to the phase angle. The time differences between phases depend on the application. For capacitor banks with grounded neutral, the three poles should close in succession with a time separation of 1/6 cycle. With ungrounded neutral, two poles should close simultaneously at phase – phase voltage zero, and the last one 1/4 cycle later.

10 Safety

10.1 Discharging devices

10.1.1 General

Each capacitor bank should be provided with means for discharging the bank after disconnection from the network.

The specified discharging times may be met by applying either internal (incorporated) discharge resistors per capacitor or, external discharge devices rated for the entire capacitor equipment.

Before touching any live parts, allow at least 10 min for the bank to self-discharge and then short-circuit each capacitor terminal together and to ground.

10.1.2 Internal resistors

Internal resistors are generally built into the individual capacitors. They are designed to insure the discharge of each capacitor, and therefore the whole bank. In a bank with several sections of capacitors in series, the residual voltage on the bank terminal is equal to the sum of the residual voltage in each section.

10.1.3 External discharge devices

External discharge devices are used in special cases. Each device should be adapted to the conditions existing at the site of erection of the equipment and have suitable strike distance, creepage path and insulation level. If the capacitors have no internal discharge resistors, there should be no isolating device between the capacitor bank and the discharge device.

Discharge reactors may be used, connected directly in parallel with the capacitor banks. Usually two reactors are connected line-to-line across two phases because of economical reasons. Under operation conditions, only the magnetizing current flows in the reactor. When switching off the capacitor equipment, all the stored energy circulates through the coil in a few seconds. Most of the energy is dissipated in the reactor. The number of discharges per unit of time should be restricted so that no overheating of the discharge reactor occurs.

Windings of transformers or motors are considered as suitable discharge impedances as well as the primary of voltage transformers.

10.1.4 Discharging after disconnection

Disconnected capacitor equipments should completely self-discharge, no matter where the discharge device is located, be it directly at each capacitor or at the connecting terminals of the equipment.

However, capacitor equipment comprising series connections and star connections, which have undergone puncturing of elements or internal or external arcing, may not be discharged completely through discharge devices connected to the terminals of the capacitor equipment. Although there is no voltage measurable at the equipment terminals, dangerous amounts of stored energy, with opposing charges, may exist in the capacitor equipment. These so-called "trapped charges" may persist over a period of several months and can only be discharged by individually discharging each section of the bank.

All the above-described risks are normally avoided by using capacitors with internal discharge resistors. However, there is a risk that a resistor may be destroyed during a capacitor failure leaving a charge on the capacitor.

It is important to note that a discharging device is not a substitute for short-circuiting the capacitor terminals together and to ground before and during handling.

10.2 Dead metallic parts

The voltage of every metallic part of the bank (frame and/or capacitor container) should be fixed. The voltage continuity is obtained by connecting the containers and frame with conducting wire of adequate size.

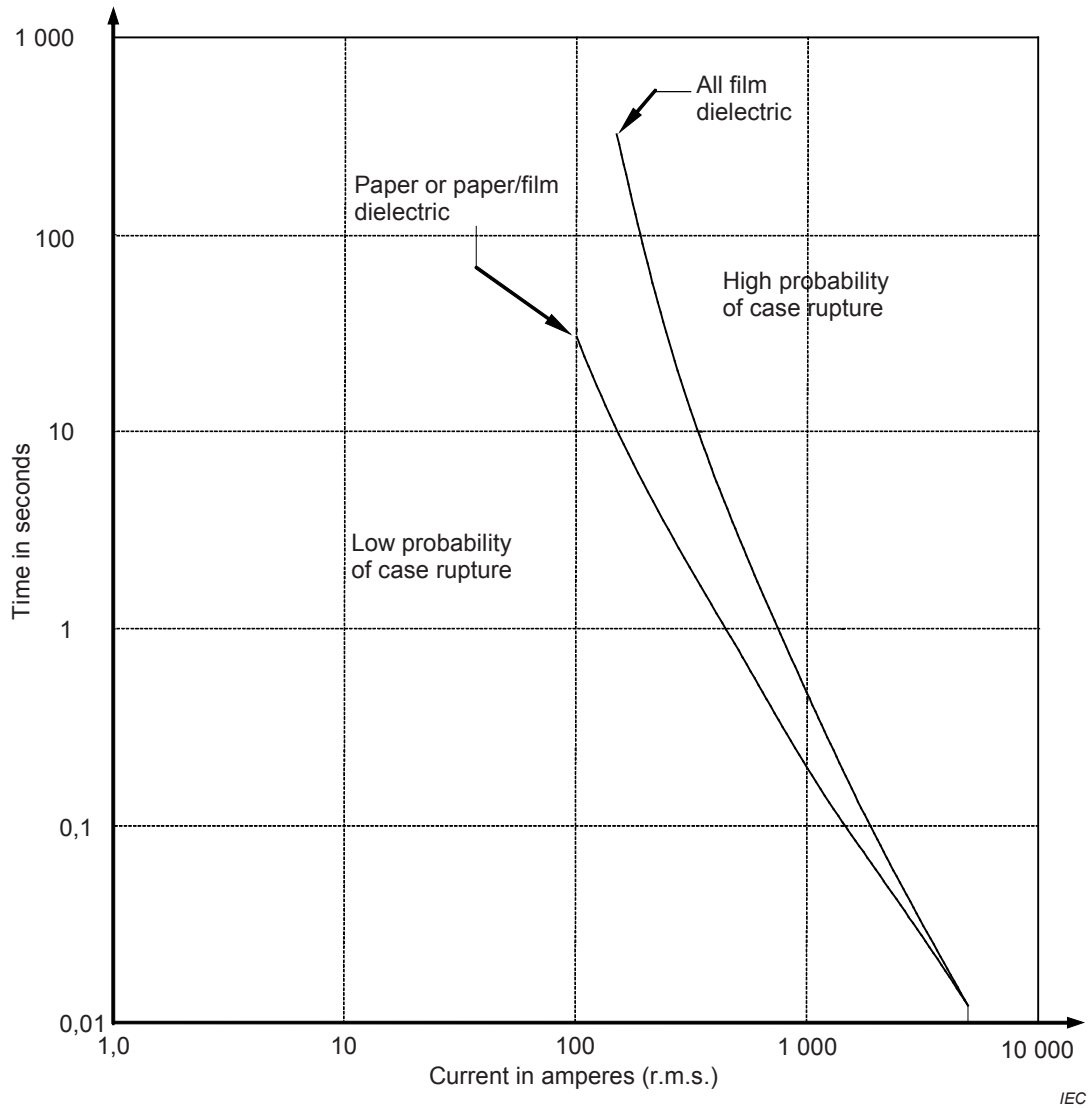

Figure 2 – Typical case rupture curves for approximately 30 000 cm³ case volume

NOTE The information contained in Figure 2 is copyrighted information of the IEEE extracted from standard IEEE 18-1992, IEEE standard for shunt power capacitors copyright ©1992 by the Institute of Electrical and Electronic Engineers, Inc. (IEEE). This information was written within the context of IEEE standard IEEE 18-1992. The IEEE takes no responsibility or liability and will assume no liability for any damages resulting from the placement and context in this publication. Information is reproduced with the permission of the IEEE.

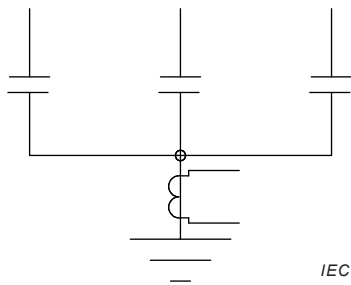

Figure 3 – Star connection with the neutral grounded through a current transformer

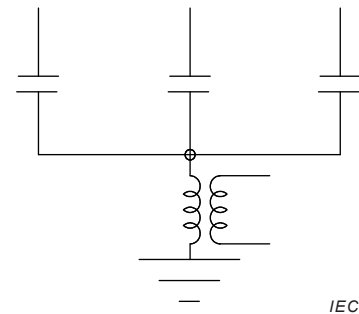

Figure 4 – Star connection with voltage transformer between neutral and ground

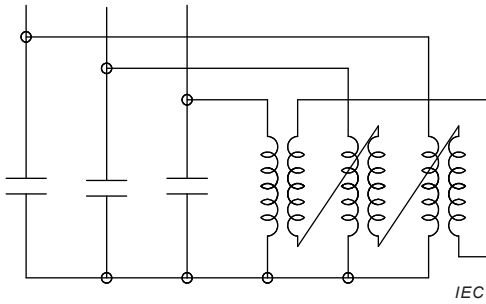

Figure 5 – Star connection with ungrounded neutral and voltage transformers connected in an open delta

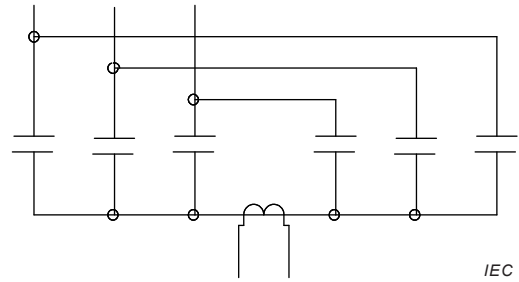

Figure 6 – Double-star connection with ungrounded neutral

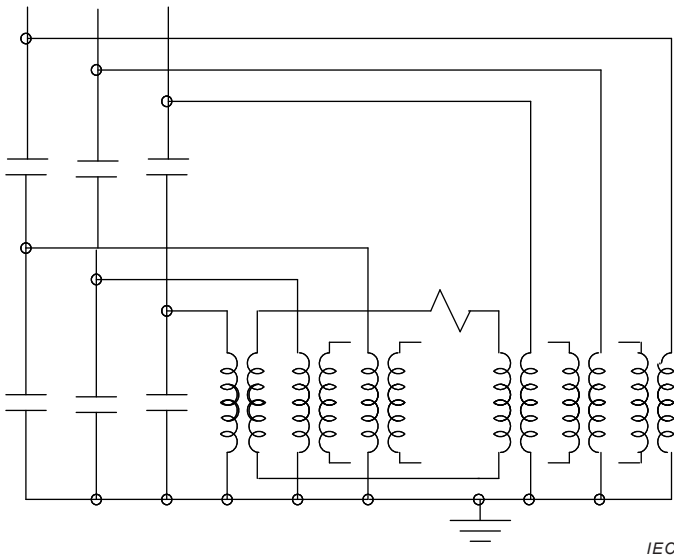

Figure 7 – Star connection with grounded neutral and voltage transformers connected in differential measurement

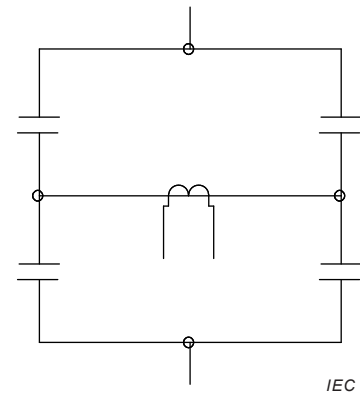

Figure 8 – Bridge connection

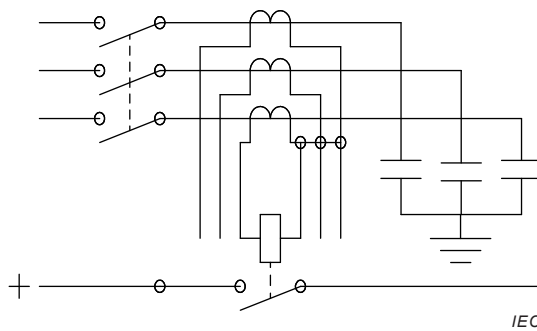
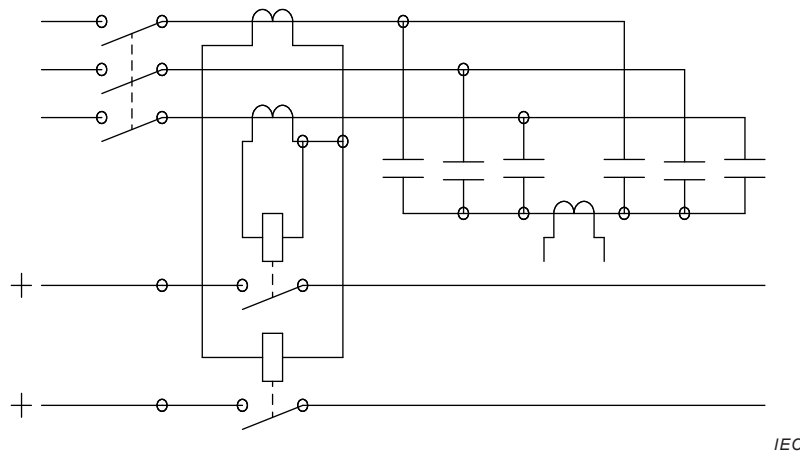

Figure 9 – Line overcurrent relays for capacitor bank, grounded



IEC

Figure 10 – Line overcurrent relays for capacitor bank, ungrounded

Table 1 – Melting currents for type-K (fast) fuse links, in amperes

Rated continuous current	300 s or 600 s melting current ¹⁾		10 s melting current		0,1 s melting current		Speed ratio
	Minimal	Maximal	Minimal	Maximal	Minimal	Maximal	
	Preferred ratings						
6	12,0	14,4	13,5	20,5	72	86	6,0
10	19,5	23,4	22,5	34	128	154	6,6
15	31,0	37,2	37,0	55	215	258	6,9
25	50	60	60	90	350	420	7,0
40	80	96	98	148	565	680	7,1
65	128	153	159	237	918	1 100	7,2
100	200	240	258	388	1 520	1 820	7,6
140	310	372	430	650	2 470	2 970	8,0
200	480	576	760	1 150	3 880	4 650	8,1
	Intermediate ratings						
8	15	18	18	27	97	116	6,5
12	25	30	29,5	44	166	199	6,6
20	39	47	48,0	71	273	328	7,0
30	63	76	77,5	115	447	546	7,1
50	101	121	126	188	719	862	7,1
80	160	192	205	307	1 180	1 420	7,4
	Ratings below 6 A						
1	2	2,4	²⁾	10	²⁾	58	–
2	4	4,8	²⁾	10	²⁾	58	–
3	6	7,2	²⁾	10	²⁾	58	–

NOTE Information in Table 1 is from Table 6 in *American National Standard C37.42 – 1989* (see bibliography) and is reproduced with the permission of the ANSI.

¹⁾ 300 s for fuse links rated 100 A and less; 600 s for fuse links rated 140 A and 200 A.

²⁾ No minimum value is indicated, since the requirement is that 1 A, 2 A, 3 A ratings shall coordinate with the 6 A rating but not necessarily with each other.

Table 2 – Melting currents for type-T (slow) fuse links, in amperes

Rated continuous current	300 s or 600 s melting current ¹⁾		10 s melting current		0,1 s melting current		Speed ratio
	Minimal	Maximal	Minimal	Maximal	Minimal	Maximal	
	Preferred ratings						
6	12,0	14,4	15,3	23,0	120	144	10,0
10	19,5	23,4	26,5	40,0	224	269	11,5
15	31,0	37,2	44,5	67,0	388	466	12,5
25	50	60	73,5	109	635	762	12,7
40	80	96	120	178	1 040	1 240	13,0
65	128	153	195	291	1 650	1 975	12,9
100	200	240	319	475	2 620	3 150	13,1
140	310	372	520	775	4 000	4 800	12,9
200	480	576	850	1 275	6 250	7 470	13,0
	Intermediate ratings						
8	15,0	18,0	20,5	31,0	166	199	11,1
12	25,0	30,0	34,5	52,0	296	355	11,8
20	39,0	47,0	57,0	85,0	496	595	12,7
<30	63,0	76	93,0	138	812	975	12,9
50	101	121	152	226	1 310	1 570	13,0
80	160	192	248	370	2 080	2 500	13,0
	Ratings below 6 A						
1	2	2,4	²⁾	11	²⁾	100	–
2	4	4,8	²⁾	11	²⁾	100	–
3	6	7,2	²⁾	11	²⁾	100	–

NOTE Information in this table is from Table 7 in *American National Standard C37.42 – 1989* (see bibliography) and is reproduced with the permission of ANSI.

¹⁾ 300 s for fuse links rated 100 A and less; 600 s for fuse links rated 140 A and 200 A.

²⁾ No minimum value is indicated, since the requirement is that 1 A, 2 A, 3 A ratings shall coordinate with the 6 A rating but not necessarily with each other.

Bibliography

IEC 61869-1, *Instrument transformers – Part 1: General requirements*

IEC 61869-2, *Instrument transformers – Part 2: Additional requirements for current transformers*

IEC 61869-5, *Instrument transformers – Part 5: Additional requirements for capacitor voltage transformers*

IEC 60417-SN, *Graphical symbols for use on equipment*

IEC 60617-SN, *Graphical symbols for diagrams*

IEEE Std 18, *IEEE Standard for shunt power capacitors*

IEEE Std 1036, *IEEE guide for application of shunt power capacitors*

IEEE Std C37.99, *IEEE guide for the protection of shunt capacitor banks*

IEEE Std C37.40, *IEEE Standard Service Conditions and Definitions for High-Voltage Fuses, Distribution Enclosed Single-Pole Air Switches, Fuse Disconnecting Switches, and Accessories*

IEEE Std C37.43, *IEEE Standard Specifications for High-Voltage Expulsion, Current-Limiting, and Combination-Type Distribution and Power Class External Fuses, with Rated Voltages from 1 kV through 38 kV, Used for the Protection of Shunt Capacitors*

British Standards Institution (BSI)

BSI is the national body responsible for preparing British Standards and other standards-related publications, information and services.

BSI is incorporated by Royal Charter. British Standards and other standardization products are published by BSI Standards Limited.

About us

We bring together business, industry, government, consumers, innovators and others to shape their combined experience and expertise into standards-based solutions.

The knowledge embodied in our standards has been carefully assembled in a dependable format and refined through our open consultation process. Organizations of all sizes and across all sectors choose standards to help them achieve their goals.

Information on standards

We can provide you with the knowledge that your organization needs to succeed. Find out more about British Standards by visiting our website at bsigroup.com/standards or contacting our Customer Services team or Knowledge Centre.

Buying standards

You can buy and download PDF versions of BSI publications, including British and adopted European and international standards, through our website at bsigroup.com/shop, where hard copies can also be purchased.

If you need international and foreign standards from other Standards Development Organizations, hard copies can be ordered from our Customer Services team.

Subscriptions

Our range of subscription services are designed to make using standards easier for you. For further information on our subscription products go to bsigroup.com/subscriptions.

With **British Standards Online (BSOL)** you'll have instant access to over 55,000 British and adopted European and international standards from your desktop. It's available 24/7 and is refreshed daily so you'll always be up to date.

You can keep in touch with standards developments and receive substantial discounts on the purchase price of standards, both in single copy and subscription format, by becoming a **BSI Subscribing Member**.

PLUS is an updating service exclusive to BSI Subscribing Members. You will automatically receive the latest hard copy of your standards when they're revised or replaced.

To find out more about becoming a BSI Subscribing Member and the benefits of membership, please visit bsigroup.com/shop.

With a **Multi-User Network Licence (MUNL)** you are able to host standards publications on your intranet. Licences can cover as few or as many users as you wish. With updates supplied as soon as they're available, you can be sure your documentation is current. For further information, email bsmusales@bsigroup.com.

BSI Group Headquarters

389 Chiswick High Road London W4 4AL UK

Revisions

Our British Standards and other publications are updated by amendment or revision.

We continually improve the quality of our products and services to benefit your business. If you find an inaccuracy or ambiguity within a British Standard or other BSI publication please inform the Knowledge Centre.

Copyright

All the data, software and documentation set out in all British Standards and other BSI publications are the property of and copyrighted by BSI, or some person or entity that owns copyright in the information used (such as the international standardization bodies) and has formally licensed such information to BSI for commercial publication and use. Except as permitted under the Copyright, Designs and Patents Act 1988 no extract may be reproduced, stored in a retrieval system or transmitted in any form or by any means – electronic, photocopying, recording or otherwise – without prior written permission from BSI. Details and advice can be obtained from the Copyright & Licensing Department.

Useful Contacts:

Customer Services

Tel: +44 845 086 9001

Email (orders): orders@bsigroup.com

Email (enquiries): cservices@bsigroup.com

Subscriptions

Tel: +44 845 086 9001

Email: subscriptions@bsigroup.com

Knowledge Centre

Tel: +44 20 8996 7004

Email: knowledgecentre@bsigroup.com

Copyright & Licensing

Tel: +44 20 8996 7070

Email: copyright@bsigroup.com



...making excellence a habit.™