



BSI Standards Publication

Electronic display devices

Part 3-2: Evaluation of optical characteristics — Mura

National foreword

This Published Document is the UK implementation of IEC/TR 62977-3-2:2016.

The UK participation in its preparation was entrusted to Technical Committee EPL/47, Semiconductors.

A list of organizations represented on this committee can be obtained on request to its secretary.

This publication does not purport to include all the necessary provisions of a contract. Users are responsible for its correct application.

© The British Standards Institution 2016.

Published by BSI Standards Limited 2016

ISBN 978 0 580 89485 5

ICS 31.120; 31.260

Compliance with a British Standard cannot confer immunity from legal obligations.

This Published Document was published under the authority of the Standards Policy and Strategy Committee on 31 January 2016.

Amendments/corrigenda issued since publication

Date	Text affected
-------------	----------------------



TECHNICAL REPORT



Electronic display devices – Part 3-2: Evaluation of optical characteristics – Mura

INTERNATIONAL
ELECTROTECHNICAL
COMMISSION

ICS 31.120; 31.260

ISBN 978-2-8322-3118-0

Warning! Make sure that you obtained this publication from an authorized distributor.

CONTENTS

FOREWORD	4
INTRODUCTION	6
1 Scope	7
2 Normative references	7
3 Terms and definitions	7
4 Standard measuring conditions	8
4.1 Standard measuring conditions	8
4.1.1 Standard measuring environmental conditions	8
4.1.2 Standard measuring darkroom conditions	8
4.2 Light measuring device (LMD)	8
4.3 Measuring setup	9
4.4 Test signal	9
4.5 Measuring conditions	10
5 Standard evaluation method	10
5.1 Measurement data processing method	10
5.2 Measurement data processing flow	10
5.2.1 General	10
5.2.2 Median filter process	11
5.2.3 Transformation to opponent colour space from CIE XYZ	12
5.2.4 Convolution with the contrast sensitivity function (CSF) of the human visual system	12
5.2.5 Transformation to CIE XYZ from the opponent colour space	12
5.2.6 Transformation to CIELAB from CIE XYZ	12
5.2.7 a^* correction	13
5.3 Mura evaluation method	13
5.3.1 General	13
5.3.2 Lightness mura evaluation	13
5.3.3 Chroma mura evaluation	15
5.3.4 Mura evaluation	16
5.3.5 Measurement report	16
6 Actual example	17
6.1 General	17
6.2 Evaluation objects	17
6.3 Subjective evaluation	17
6.4 Evaluation by the method indicated in this document using apparatus	18
6.5 Correlation between subjective evaluation and mura evaluation value	19
Annex A (informative) S-CIELAB model	20
A.1 General	20
A.2 S-CIELAB model	20
A.3 Spatial sensitivity function model (two-dimensional CSF model)	20
Annex B (informative) Type of mura	24
B.1 General	24
B.2 Classification of mura	24
Annex C (informative) Use case of a mura evaluation value	26
C.1 General	26

C.2	Example of a use case of a mura evaluation value	26
Annex D (informative)	Various mura measurement methods	27
D.1	General.....	27
D.2	Comparison of mura evaluation standards	27
Bibliography.....		28
Figure 1	– Measuring layout.....	9
Figure 2	– Example of input signal	10
Figure 3	– Measurement data processing flow adopting the S-CIELAB model	11
Figure 4	– Concept diagram of real-space information integration	14
Figure 5	– 3 × 3 neighbourhood domain	15
Figure 6	– Evaluation objects in a dark room	17
Figure 7	– CSF filter images in opponent colour space	18
Figure 8	– Correlation of mura evaluation value and ITU-R subjective evaluation values	19
Figure A.1	– Flowchart of S-CIELAB calculation.....	20
Figure A.2	– Two-dimensional CSF model	21
Figure A.3	– Examples of the convolution of a two-dimensional CSF filter for illusion.....	23
Figure B.1	– Classification of mura by forms and/or causes	25
Table 1	– Example of reported criteria of two-dimensional LMD	9
Table 2	– Example of measurement results for a display screen uniformity	16
Table 3	– ITU-R quality and impairment scales	17
Table 4	– Subjective evaluation results	18
Table 5	– Evaluation results by apparatus.....	19
Table A.1	– Parameters for each axis of the opponent colour space	21
Table C.1	– Example of a use case of a mura evaluation value	26
Table C.2	– Example of subjects to evaluate.....	26
Table D.1	– Comparison chart of various mura measurement standards	27

INTERNATIONAL ELECTROTECHNICAL COMMISSION

ELECTRONIC DISPLAY DEVICES –**Part 3-2: Evaluation of optical characteristics – Mura**

FOREWORD

- 1) The International Electrotechnical Commission (IEC) is a worldwide organization for standardization comprising all national electrotechnical committees (IEC National Committees). The object of IEC is to promote international co-operation on all questions concerning standardization in the electrical and electronic fields. To this end and in addition to other activities, IEC publishes International Standards, Technical Specifications, Technical Reports, Publicly Available Specifications (PAS) and Guides (hereafter referred to as "IEC Publication(s)"). Their preparation is entrusted to technical committees; any IEC National Committee interested in the subject dealt with may participate in this preparatory work. International, governmental and non-governmental organizations liaising with the IEC also participate in this preparation. IEC collaborates closely with the International Organization for Standardization (ISO) in accordance with conditions determined by agreement between the two organizations.
- 2) The formal decisions or agreements of IEC on technical matters express, as nearly as possible, an international consensus of opinion on the relevant subjects since each technical committee has representation from all interested IEC National Committees.
- 3) IEC Publications have the form of recommendations for international use and are accepted by IEC National Committees in that sense. While all reasonable efforts are made to ensure that the technical content of IEC Publications is accurate, IEC cannot be held responsible for the way in which they are used or for any misinterpretation by any end user.
- 4) In order to promote international uniformity, IEC National Committees undertake to apply IEC Publications transparently to the maximum extent possible in their national and regional publications. Any divergence between any IEC Publication and the corresponding national or regional publication shall be clearly indicated in the latter.
- 5) IEC itself does not provide any attestation of conformity. Independent certification bodies provide conformity assessment services and, in some areas, access to IEC marks of conformity. IEC is not responsible for any services carried out by independent certification bodies.
- 6) All users should ensure that they have the latest edition of this publication.
- 7) No liability shall attach to IEC or its directors, employees, servants or agents including individual experts and members of its technical committees and IEC National Committees for any personal injury, property damage or other damage of any nature whatsoever, whether direct or indirect, or for costs (including legal fees) and expenses arising out of the publication, use of, or reliance upon, this IEC Publication or any other IEC Publications.
- 8) Attention is drawn to the Normative references cited in this publication. Use of the referenced publications is indispensable for the correct application of this publication.

The main task of IEC technical committees is to prepare International Standards. However, a technical committee may propose the publication of a technical report when it has collected data of a different kind from that which is normally published as an International Standard, for example "state of the art".

IEC TR 62977-3-2, which is a technical report, has been prepared by IEC technical committee 110: Electronic display devices.

The text of this technical report is based on the following documents:

Enquiry draft	Report on voting
110/674A/DTR	110/701A/RVC

Full information on the voting for the approval of this technical report can be found in the report on voting indicated in the above table.

This publication has been drafted in accordance with the ISO/IEC Directives, Part 2.

A list of all parts in the IEC 62977 series, published under the general title *Electronic display devices*, can be found on the IEC website.

The committee has decided that the contents of this publication will remain unchanged until the stability date indicated on the IEC website under "<http://webstore.iec.ch>" in the data related to the specific publication. At this date, the publication will be

- reconfirmed,
- withdrawn,
- replaced by a revised edition, or
- amended.

A bilingual version of this publication may be issued at a later date.

IMPORTANT – The 'colour inside' logo on the cover page of this publication indicates that it contains colours which are considered to be useful for the correct understanding of its contents. Users should therefore print this document using a colour printer.

INTRODUCTION

Electronic displays, for example liquid crystal displays (LCDs), plasma display panels (PDPs), organic light emission displays (OLEDs), and so on, have grown popular as displays for high-quality images. It is therefore increasingly important to measure the image quality of electronic displays. One factor degrading the image quality is non-uniformity, known as 'mura'. The mura is classified into three types. The first is luminance mura, the second is colour mura. The third is called merely "mura" and includes luminance mura and colour mura simultaneously. It is impossible to recognize luminance mura and colour mura as completely separate objects.

Various measurement methods about luminance mura and colour mura have been reported in various academic conferences. There are also some standards for these mura. For example, uniformity of luminance and chromaticity are specified in IEC IEC 61747-30-1, SEMU (SEMI mura) is specified in SEMI D31-0213 and uniformity measurement is specified in IDMS ver.1.03 sec. 8. However there is no report which clearly provides the quantitative method for the mura that is called merely "mura" (see Annex D).

Therefore the majority of electronic display manufacturers are still using the limit sample for visual inspection.

This Technical Report, which intends to verify one mura measurement method, shows the detailed mura measurement method and its inspection experiment results.

The International Electrotechnical Commission (IEC) draws attention to the fact that it is claimed that compliance with this document may involve the use of a patent.

IEC takes no position concerning the evidence, validity and scope of this patent right.

The holder of this patent right has assured the IEC that he/she is willing to negotiate licences either free of charge or under reasonable and non-discriminatory terms and conditions with applicants throughout the world. In this respect, the statement of the holder of this patent right is registered with IEC. Information may be obtained from:

Sony Corporation

1-7-1 Konan, Minato-ku, Tokyo, 108-0075 Japan

Attention is drawn to the possibility that some of the elements of this document may be the subject of patent rights other than those identified above. IEC shall not be held responsible for identifying any or all such patent rights.

ISO (www.iso.org/patents) and IEC (<http://patents.iec.ch>) maintain on-line database of patents relevant to their standards. Users are encouraged to consult the databases for the most up to date information concerning patents.

ELECTRONIC DISPLAY DEVICES –

Part 3-2: Evaluation of optical characteristics – Mura

1 Scope

This part of IEC 62977, which is a Technical Report, provides an optical measuring method of mura for electronic displays. It defines general measuring procedures for mura measurement and an evaluation method of electronic displays.

2 Normative references

The following documents, in whole or in part, are referenced in this document and are indispensable for its application. For dated references, only the edition cited applies. For undated references, the latest edition of the referenced document (including any amendments) applies.

Void.

3 Terms and definitions

For the purposes of this document, the following terms and definitions apply.

3.1

lightness mura

luminance unevenness whose lightness differs partially from the background lightness of a display screen with the exception of pixel defects

3.2

chroma mura

colour unevenness whose chroma differs partially from the background of a display screen with the exception of pixel defects

3.3

mura

both luminance and colour unevenness whose lightness and chroma differ partially from the background of a display screen with the exception of pixel defects

Note 1 to entry: In general, lightness mura and chroma mura exist simultaneously. Mura evaluation shows the degree of screen uniformity considering how both lightness mura and chroma mura affect human perception.

3.4

lightness edge area

ratio of lightness gradient area that is rapidly changed lightness to whole screen area

3.5

lightness mura area

area of uneven lightness that is bright or dark regions against the background of a display screen

3.6

maximum lightness difference

maximum lightness difference from the average L^* of a whole display screen

3.7**chroma edge area**

ratio of the chroma gradient area that is rapidly changed from the chroma to the whole screen area

3.8**chroma mura area**

area of uneven chroma that is coloured regions against the background of a display screen

3.9**maximum chroma**

maximum C^* value in a whole display screen

3.10**opponent colour space**

three dimensions that are described as w/k , r/g , and b/y channels

Note 1 to entry: The w/k channel is a luminance component. The r/g and b/y channels are a chromaticity component of red to green, blue to yellow, respectively.

4 Standard measuring conditions**4.1 Standard measuring conditions****4.1.1 Standard measuring environmental conditions**

The standard measuring environmental conditions specified in IEC 62341-6-1:2009, 5.1, should be applied. [1]¹

4.1.2 Standard measuring darkroom conditions

The standard measuring darkroom conditions specified in IEC 62341-6-1:2009, 5.2, should be applied. [1]

4.2 Light measuring device (LMD)

The LMD used for measurements of the displays should be checked for the following criteria and specified accordingly:

- sensitivity of the measured quantity;
- errors caused by veiling glare and lens flare (i.e. stray light in optical system);
- errors caused by camera noise (i.e. dark charge noise of a charge coupled device (CCD));
- timing of data-acquisition and aliasing-effects;
- linearity of detection and data conversion;
- resolution when using a two-dimensional LMD.

A two-dimensional LMD such as a CCD area detector should be used for these measurements. When using a two-dimensional LMD, it should be calibrated, so that the measurement results correspond to those by the point-measurement LMD.

A two-dimensional LMD measures a map of luminance and/or colour coordinate values over the measurement area of the screen. The specification of the LMD used should be noted in the report as shown in Table 1 for example.

¹ Numbers in square brackets refer to the Bibliography.

It is important to avoid moiré and flicker effect when using a two-dimensional LMD. If a moiré pattern appears in the image, the measuring conditions specified in IDMS version 1.03 Sec. 8.2 should be applied. The measuring condition specified in IDMS ver. 1.03 A4.2.1 should be applied to avoid the flicker effect. [3]

NOTE 1 The point-measurement LMD measures the luminance and/or colour coordinate at each measurement point on the screen. A two-dimensional LMD measures the map of luminance and/or colour coordinate over the measurement area of the screen.

NOTE 2 A point-measurement LMD usually has higher sensitivity than a two-dimensional LMD. A two-dimensional LMD measures the uniformity of the measuring area more easily than a point-measurement LMD.

Table 1 – Example of reported criteria of two-dimensional LMD

CCD resolution (measurement points)	980 × 980	
Luminance range	0,05 cd/m ² to 100 000 cd/m ² (with ND filter)	
Wavelength range	380 nm to 780 nm	
System accuracy	Luminance variation	±3 %
	Colour coordinates (x, y)	±0,005
Colorimetric filters	CIE1931 matched colour filters	

4.3 Measuring setup

The measuring layout is shown in Figure 1.

The LMD should be set at a proper field angle and distance to be able to take the whole screen area.

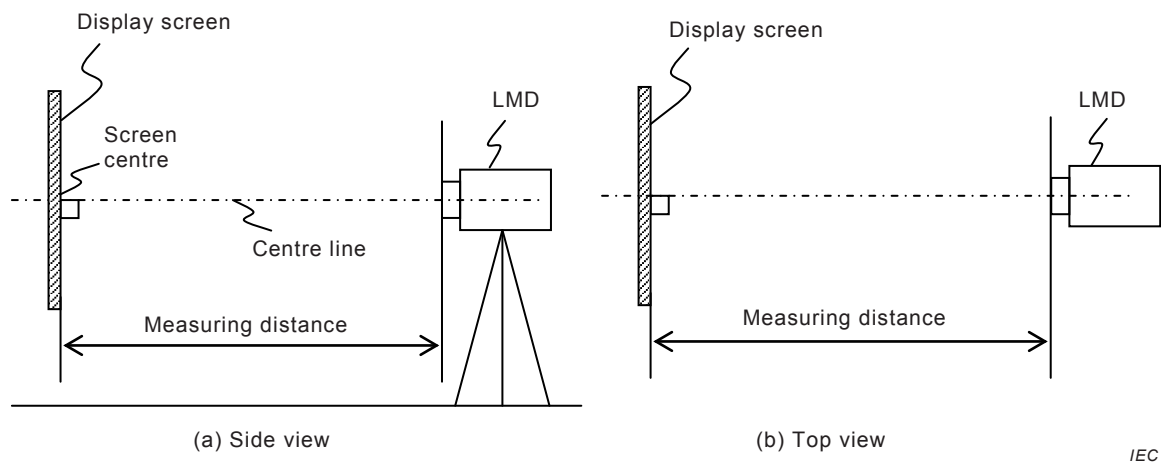

IEC

Figure 1 – Measuring layout

4.4 Test signal

A full white or gray signal is input into a display. The input signal level is determined by an evaluator and it should be noted in the measurement report.

The signal level should be specified at 0 %, 20 %, 50 %, 100 % of full white (see Figure 2).

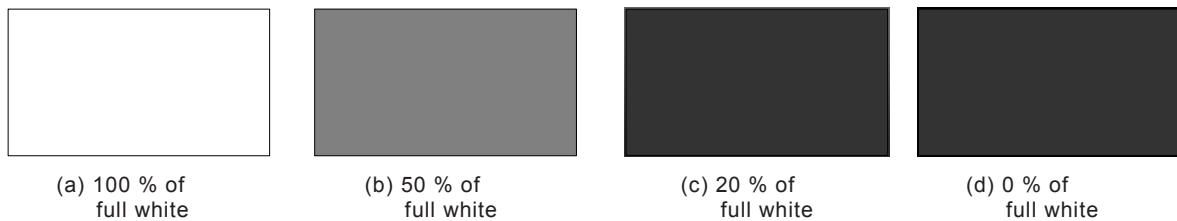

IEC

Figure 2 – Example of input signal

4.5 Measuring conditions

The measuring conditions are as follows:

- a) The shutter speed (exposure time) of the LMD should be determined so as to be synchronized with the display (or backlight) scan timing.
- b) The diaphragm stop of the LMD should be determined so as to obtain the proper saturation level of the charged capacity of the image sensor (CCD, complementary metal oxide semiconductor (CMOS)).

The evaluator should specify the factors of noise in the measuring conditions and strive to minimize those effects on the measurement data.

5 Standard evaluation method

5.1 Measurement data processing method

The measurement data should be outputted as three maps of CIE tristimulus values (X , Y , Z) using the two-dimensional LMD constructed in a CCD area detector and with CIE 1931 matched colour filters.

5.2 Measurement data processing flow

5.2.1 General

The measurement data processing flow is shown in Figure 3. The data is processed based on the S-CIELAB model (see Annex A).

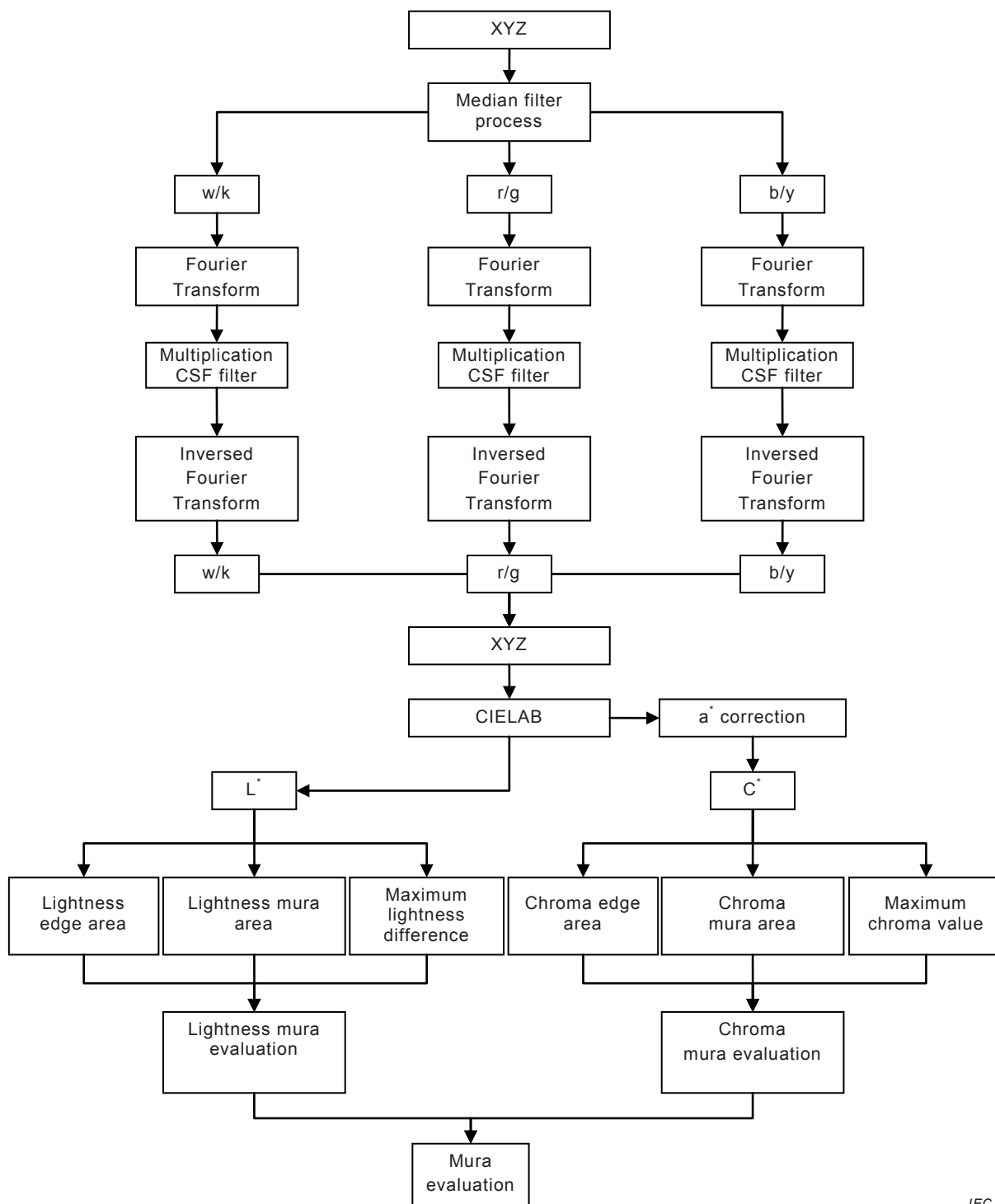

IEC

Figure 3 – Measurement data processing flow adopting the S-CIELAB model

5.2.2 Median filter process

The measurement data should be processed with a median filter to eliminate the noise of the LMD or the measuring conditions or any other factors.

It is recommended to consider which filter size should be used in accordance with the noise level. The amount of median filtering will affect the spatial frequency analysis. To minimize its impact, a small window size should be selected. For example, a (3 × 3) pixels or (5 × 5) pixels window size minimizes this impact. By selecting these sizes, the elimination of the

background sensor noise of the LMD is significant. A multiple measurement or long exposure time is effective for elimination of this background noise.

5.2.3 Transformation to opponent colour space from CIE XYZ

The following determinant should be applied to convert CIE XYZ to w/k , r/g , and b/y .

$$\begin{pmatrix} w/k \\ r/g \\ b/y \end{pmatrix} = \begin{pmatrix} 0,279 & 0,720 & -0,107 \\ -0,449 & 0,290 & -0,077 \\ 0,086 & -0,590 & 0,501 \end{pmatrix} \begin{pmatrix} X \\ Y \\ Z \end{pmatrix} \quad (1)$$

5.2.4 Convolution with the contrast sensitivity function (CSF) of the human visual system

Each of the opponent colour data was convolved with the visual spatial sensitivity function filter to that colour dimension.

A screen image is perceived through human eyes. Therefore, it is important to consider the characteristics of the human visual system for the evaluation. The spatial contrast sensitivity function is one useful characteristic for the evaluation of screen image quality (see Annex A).

NOTE The CSF of the human visual system does not have isotropic properties, insofar as the CSF in the vertical and horizontal directions is superior to the CSF in the diagonal direction. Therefore, it is better to consider using a modified S-CILEAB model.

5.2.5 Transformation to CIE XYZ from the opponent colour space

The following determinant should be applied to convert w/k , r/g , and b/y to CIE XYZ.

$$\begin{pmatrix} X \\ Y \\ Z \end{pmatrix} = \begin{pmatrix} 0,279 & 0,720 & -0,107 \\ -0,449 & 0,290 & -0,077 \\ 0,086 & -0,590 & 0,501 \end{pmatrix}^{-1} \begin{pmatrix} w/k \\ r/g \\ b/y \end{pmatrix} \quad (2)$$

5.2.6 Transformation to CIELAB from CIE XYZ

The measurement data should be converted to CIELAB colour space as specified in CIE 15. [2].

$$\begin{aligned} L^* &= 116 f(Y/Y_n) - 16 \\ a^* &= 500 [f(X/X_n) - f(Y/Y_n)] \\ b^* &= 200 [f(Y/Y_n) - f(Z/Z_n)] \end{aligned} \quad (3)$$

where

$$\begin{aligned} f(X/X_n) &= (X/X_n)^{1/3} & \text{if } (X/X_n) > (24/116)^3 \\ f(X/X_n) &= (841/108)(X/X_n) + 16/116 & \text{if } (X/X_n) \leq (24/116)^3 \end{aligned} \quad (4)$$

and

$$\begin{aligned} f(Y/Y_n) &= (Y/Y_n)^{1/3} & \text{if } (Y/Y_n) > (24/116)^3 \\ f(Y/Y_n) &= (841/108)(Y/Y_n) + 16/116 & \text{if } (Y/Y_n) \leq (24/116)^3 \end{aligned} \quad (5)$$

and

$$f(Z/Z_n) = (Z/Z_n)^{1/3} \quad \text{if } (Z/Z_n) > (24/116)^3 \quad (6)$$

$$f(Z/Z_n) = (841/108)(Z/Z_n) + 16/116 \quad \text{if} \quad (Z/Z_n) \leq (24/116)^3$$

Here X_n , Y_n , and Z_n are determined as follows.

$$\begin{pmatrix} X_n \\ Y_n \\ Z_n \end{pmatrix} = (Y_{\max} / Y_0) \begin{pmatrix} X_0 \\ Y_0 \\ Z_0 \end{pmatrix} \quad (7)$$

where

Y_{\max} is the highest value of Y in the measurement data

X_0 is the most frequent value of X in the measurement data

Y_0 is the most frequent value of Y in the measurement data

Z_0 is the most frequent value of Z in the measurement data

The slight shift of the white point depending on the input signal level should not be judged as mura. However, if (X_n, Y_n, Z_n) are defined as the measurement data at 100 % of full white input, the whole screen may be judged as a whole colour mura at another input level. To avoid this error, (X_n, Y_n, Z_n) are defined in the above formula using the most frequent value in each measurement data.

CIE 1976 a, b (CIELAB) chroma, C^*_{ab} , specified in CIE 15 is calculated in the formula below. [2]

$$C^*_{ab} = (a^{*2} + b^{*2})^{1/2} \quad (8)$$

5.2.7 a^* correction

The a^* value should be expanded by multiplying by 1,4 if it is a positive value. This a^* correction is described in detail in [5]. In the human visual system, a reddish uneven colour is perceived as a worse degree of mura than other colours. In order to correct this human perception which is reflected in the Helmholtz–Kohlrausch effect, expansion of a^* should be used for chroma mura evaluation.

5.3 Mura evaluation method

5.3.1 General

The L^* value should be used for lightness mura analysis, and the C^* value should be used for chroma mura analysis. This mura evaluation method provides a degree of perceived mura. The higher the evaluation value, the worse the perception of mura is.

5.3.2 Lightness mura evaluation

5.3.2.1 General

The purpose of this measurement is to evaluate the lightness mura of the display screen. The following formula described in [6] should be applied to compute a lightness mura evaluation value.

$$LEV = 1,90 L_{ma} + 0,186 L_{ml} + 19,9 L_{ea} \quad (9)$$

where

LEV is the lightness mura evaluation value

- L_{ma} is the lightness mura area (see 5.3.2.3)
- L_{ml} is the maximum lightness difference (see 5.3.2.4)
- L_{ea} is the lightness edge area (see 5.3.2.2)

5.3.2.2 Lightness edge area

Lightness gradient is calculated by a sobel operation. In order to support various display sizes, viewing distances and resolutions of LMD, the lightness edge should be defined as a lightness gradient per degree of the observer's viewing angle, considering the human visual system described in [7]. Since the sobel value is the amount of change per CCD pixel, the calculation method of the lightness edge is represented by the following formula and its concept is shown in Figure 4.

$$E_d = S_o \times G_F \tag{10}$$

$$G_F = H_R \times 2 \times V_D \times \tan (0,5) / W_L \text{ [CCD pixel/degree]} \tag{11}$$

where

- E_d is the edge value
- S_o is the sobel value
- G_F is the geometric factor relating the measured screen image with real-space information
- H_R is the horizontal pixel number of the measured screen image by the LMD (CCD pixel)
- V_D is the viewing distance (in mm)
- W_L is the width of the display screen (in mm)

H_R is not the display pixel of the DUT. It should be provided by counting the number of dots of the measured screen image.

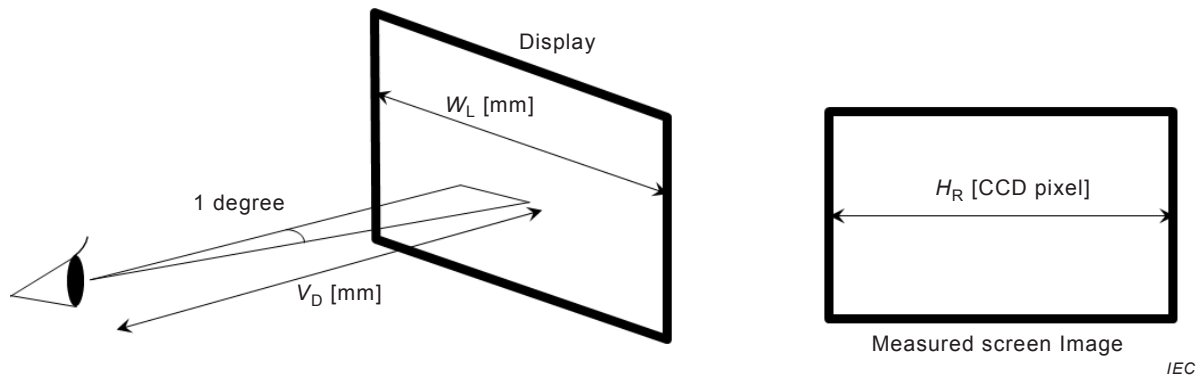

Figure 4 – Concept diagram of real-space information integration

The threshold of the lightness edge should also be defined as a lightness gradient per degree of the observer's viewing angle. A lightness gradient of more than 13 per degree on a display screen is determined as the lightness edge as described in detail in [7].

The lightness edge area is computed as the pixel count ratio of the lightness edge to the pixel count of the whole screen area.

A sobel operation is conducted to extract the major edge of the image. The following determinant should be applied for the calculation.

S_o is for pixel “E” in Figure 5.

$$S_o = (E_x^2 + E_y^2)^{1/2} \quad (12)$$

where

$$E_x = (C + 2F + I) - (A + 2D + G) \quad (13)$$

$$E_y = (A + 2B + C) - (G + 2H + I)$$

NOTE A to H are the L^* value of each pixel in the 3×3 neighbourhood domain (see Figure 5).

A	B	C
D	E	F
G	H	I

IEC

Figure 5 – 3×3 neighbourhood domain

5.3.2.3 Lightness mura area

The lightness mura area is computed as the pixel count ratio of the area whose lightness difference is more than 0,3 from the average L^* value on a display screen to the pixel count of the whole screen area.

5.3.2.4 Maximum lightness difference

The maximum L^* difference is defined as the value of the maximum lightness difference from the average L^* value of the whole display screen.

5.3.3 Chroma mura evaluation

5.3.3.1 General

The purpose of this measurement is to evaluate the chroma mura of the display screen. Formula (14), described in detail in [6], should be applied to compute a chroma mura evaluation value.

$$CEV = 3,97 C_{ma} + 0,0160 C_{mc} + 12,8 C_{ea} \quad (14)$$

where

CEV is the chroma mura evaluation value

C_{ma} is the chroma mura area (see 5.3.3.3)

C_{mc} is the maximum chroma (see 5.3.3.4)

C_{ea} is the chroma edge area (see 5.3.3.2)

5.3.3.2 Chroma edge area

The chroma gradient is calculated by a sobel operation and the same calculation method as the lightness edge shown in Figure 4. The threshold of chroma edge should also be defined as a chroma gradient per degree of the observer's viewing angle. The chroma gradient of more than 52 per degree on a display screen is defined as a chroma edge described in detail in [7].

The chroma edge area is computed as the pixel count ratio of the chroma edge to the pixel count of the whole screen area.

5.3.3.3 Chroma mura area

The chroma mura area is computed as the pixel count ratio of the area whose chroma value is more than 2 on a display screen to the pixel count of the whole screen area.

5.3.3.4 Maximum chroma

The maximum C^* value in the whole display screen is defined as maximum chroma.

5.3.4 Mura evaluation

The purpose of this measurement is to evaluate the mura of the display screen. Formula (15), described in detail in [6], should be applied to compute a mura evaluation value.

$$MEV = 0,705 LEV + 0,634 CEV \tag{15}$$

where

MEV is the mura evaluation value

5.3.5 Measurement report

The measured result should be reported in a table. Table 2 shows an example.

Table 2 – Example of measurement results for a display screen uniformity

Measuring item	Evaluation value	Signal level	50 % of full white
Mura evaluation value	3,80	Classification of mura (see Annex B)	Frame mura
Lightness mura evaluation value	3,61		
Chroma mura evaluation value	1,98		

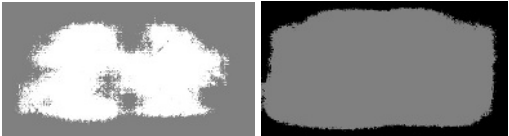
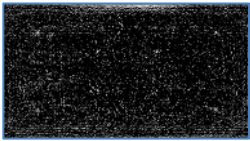
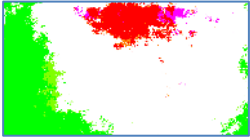
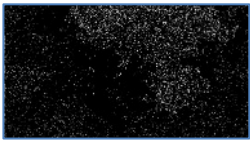
Mura evaluation index	Value of index	Mura image
Lightness mura area	0,671	 <p>Bright area Dark area</p>
Maximum lightness difference	3,01	
Lightness edge area	0,089	
Chroma mura area	0,312	
Maximum chroma	5,65	
Chroma edge area	0,051	

6 Actual example

6.1 General

The following is an actual example of mura evaluation values computed with the above measurement method and of the correlation of these values and subjective evaluation values. All the data in Clause 6 is reported in [8].

6.2 Evaluation objects

The evaluation objects were three commercially available 55-inch TVs and one 25-inch professional master monitor installed in a dark room as shown in Figure 6. Three input signal levels (100 %, 50 % and 20 % of full white described in 4.4) were used. Therefore, the evaluation subjects included 12 conditions.



Figure 6 – Evaluation objects in a dark room

6.3 Subjective evaluation

A subjective evaluation was conducted using the five-grade impairment scale based on [13] and shown in Table 3. The visual inspection criteria column in Table 3 shows the criteria that are generally used by a manufacturer inspector. These criteria should be noted because they are affected by the application of the displays: commercial model TVs, PC monitors, broadcast reference monitors, medical monitors and so on (see Annex C). In this experiment, participants were instructed to evaluate a commercial model TV. There is one more point to be careful about when performing a subjective evaluation. Because it is impossible to recognize lightness mura and chroma mura as completely separated objects, the subjective evaluation value corresponds to *MEV* (mura evaluation value). There were 8 participants who evaluated the degree of mura by watching each display screen at a distance of three times the display height from the display screen.

Table 3 – ITU-R quality and impairment scales

Grade	Quality	Impairment	Visual inspection criteria
5	Excellent	Imperceptible	Almost no effect
4	Good	Perceptible, but not annoying	Can be seen, but no effect on the customer
3	Fair	Slightly annoying	Acceptable level
2	Poor	Annoying	Can be seen, and not an acceptable level
1	Bad	Very annoying	Very bad

The results of the subjective evaluation are shown in Table 4. The bottom row in Table 4 shows the average value of each stimulus to compare with the mura evaluation value.

Table 4 – Subjective evaluation results

Signal level (%)	55-inch TV no. 1			55-inch TV no. 2			55-inch TV no. 3			25-inch Master monitor		
	20	50	100	20	50	100	20	50	100	20	50	100
A	1	3	3	2,5	4	4	4	4,5	5	5	5	5
B	1,5	3	3	3	4	4	4	4	5	5	5	5
C	1	2	2	2	3	3	4	4	5	5	5	5
D	1	2	1	2	3	4	2	3	4	3	4	3
E	2,3	2,8	2,8	2,8	3,2	3	4	4,2	4	4,5	4,8	4,5
F	2	3	3	2,5	2,5	3	3	4	4	5	5	5
G	2	3,5	4	3,5	4,5	4,5	4	4,5	5	5	5	5
H	1,5	3	3	3	4	4	3	4	4	5	5	5
Average	1,5	2,8	2,7	2,7	3,5	3,7	3,5	4	4,5	4,7	4,9	4,7

NOTE The letters A to H indicate each participant.

6.4 Evaluation by the method indicated in this document using apparatus

According to Clause 4, the measurement with the apparatus was performed. A 2D colorimeter was used to obtain an XYZ 2D distribution data of 12 conditions which were same as the subjective evaluation in the dark room. The evaluation was performed according to Clause 5. To calculate *MEV*, an analysis software that implemented this evaluation method was prepared. Figure 7 shows the example of CSF filter images for each axis of the opponent colour space computed based on Annex A. A CSF filter set should be computed for each measurement image, based upon display size, viewing distance, and measured XYZ image.

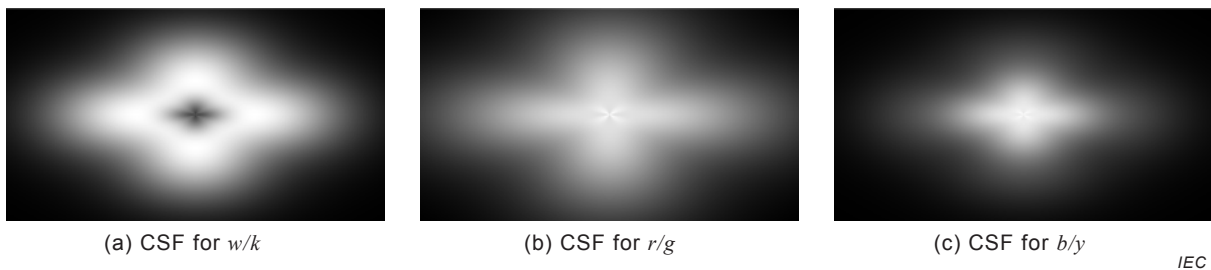

Figure 7 – CSF filter images in opponent colour space

The evaluation results are shown in Table 5. The comparison with the subjective evaluation value is impossible for lightness mura and chroma mura, but the evaluation values for these are listed for reference.

Table 5 – Evaluation results by apparatus

	55-inch TV no.1			55-inch TV no.2			55-inch TV no. 3			25-inch Master monitor		
	20	50	100	20	50	100	20	50	100	20	50	100
Signal level (%)	20	50	100	20	50	100	20	50	100	20	50	100
<i>MEV</i> (mura evaluation value)	15,7	6,7	6,7	10,7	5,6	3,6	4,5	2,8	1,5	1,6	1,3	1,1
Lightness mura evaluation value	13	4,8	4,5	9,9	4,1	3,6	2,1	1,6	0,6	0,6	0,4	0,3
Chroma mura evaluation value	9,9	4,7	5,5	6	1,5	1,6	4,7	2,7	1,8	1,8	1,5	1,5

6.5 Correlation between subjective evaluation and mura evaluation value

The correlation between the subjective evaluation value (in Table 4) and the mura evaluation value (in Table 5) is shown in Figure 8. The results show a high correlation ($R^2 = 0,90$). These results lead to the conclusion that a visual inspection can be replaced with the mura measurement method described in this document.

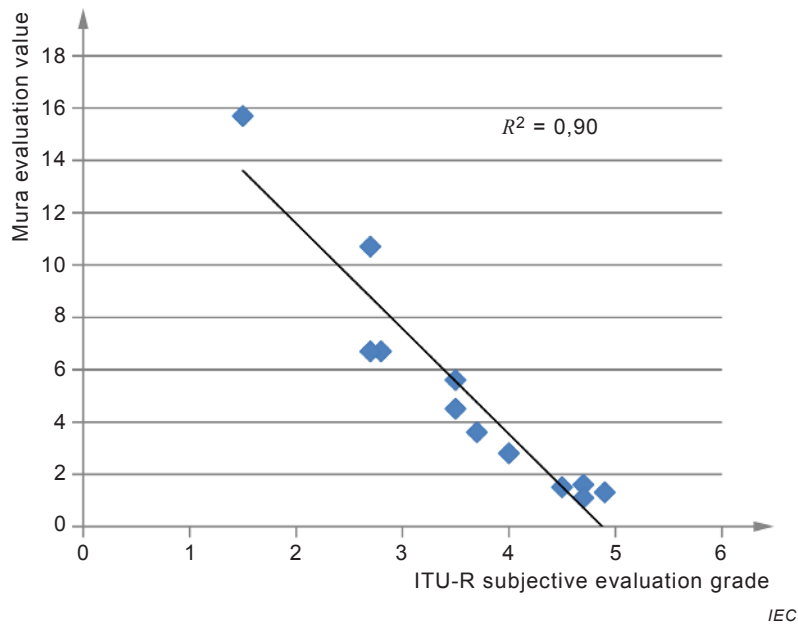

Figure 8 – Correlation of mura evaluation value and ITU-R subjective evaluation values

Annex A
(informative)

S-CIELAB model

A.1 General

A screen image is perceived through human eyes. Therefore, it is important to consider the characteristics of the human visual system for the evaluation. The spatial contrast sensitivity function is one of the useful characteristics for the evaluation of screen image quality. The CSF (contrast sensitivity function) is defined as the relationship between the spatial frequency and the contrast sensitivity of a human visual system. In this document, the CSF of the human visual system is introduced for measurement data processing to match the evaluation result to the human perception.

A.2 S-CIELAB model

The S-CIELAB model was proposed for the measurement of the colour reproduction error in digital image by Zhang and Wandell in 1997. [9] Figure A.1 shows how to calculate the S-CIELAB representation. The image data is transformed into an opponent colour space. Each opponent colour image is convolved with a kernel whose shape is determined by the visual spatial sensitivity to that colour dimension. The filtered representation is transformed into a CIE XYZ representation, and this representation is transformed using the CIELAB formulae.

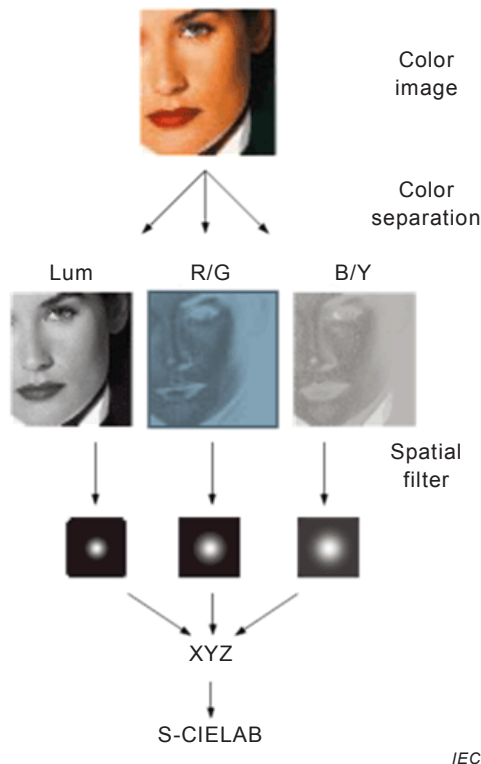

Figure A.1 – Flowchart of S-CIELAB calculation

A.3 Spatial sensitivity function model (two-dimensional CSF model)

The dependence of directivity in the spatial frequency characteristics of the human eye was measured. The result shows the anisotropic properties of contrast sensitivities in spatial frequency. The contrast sensitivity of the vertical and horizontal directions is superior to that of the diagonal direction (see Figure A.2). Based on this result, a two-dimensional CSF model

of the human eye was proposed by Miyake. [10], [11], [12] It is therefore this two-dimensional CSF model of the human eye considered with anisotropic properties which is intended to reflect more accurate characteristics of the human visual system for the evaluation.

NOTE 1 In references [9] to [12], the authors have used the word “MTF (modulation transfer function) of the eye” instead of “CSF”. To avoid any confusion, “CSF” is used to represent the spatial frequency characteristics of the human eye.

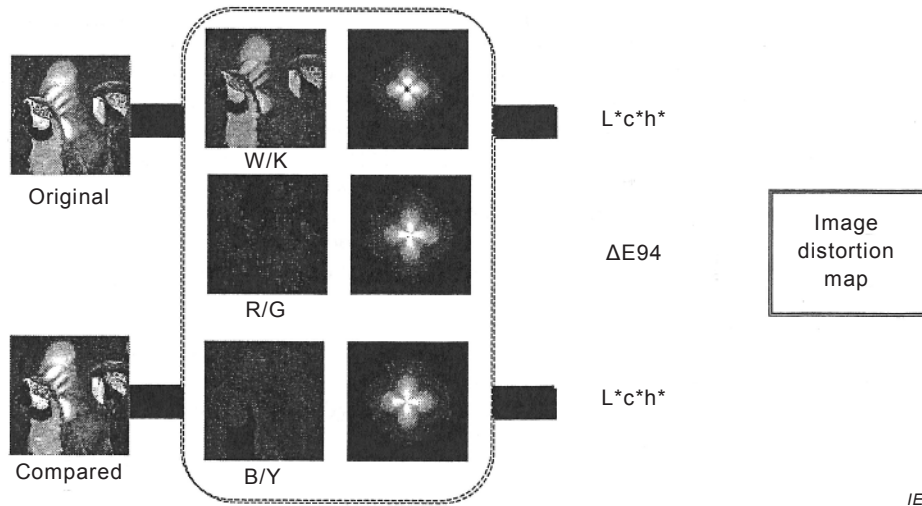

NOTE ΔE94 is a colour difference defined in CIE 114-1994. [14]

Figure A.2 – Two-dimensional CSF model

The dependence of directivity in the two-dimensional CSF model of the human eye is calculated with the following formula specified in [10] and given in more detail in [12].

$$M_{eye}(u, v) = M_0(\omega)[1 - \{1 - \gamma(\omega)\} |\sin^2(2\varphi)|] \tag{A.1}$$

where

$$\omega = (u^2 + v^2)^{1/2} \tag{A.2}$$

$$\varphi = \tan^{-1}(u/v)$$

(u, v) is the spatial frequency coordinate in (cycle per degree)

$M_0(\omega)$ is the spatial frequency characteristics of the horizontal direction

$$M_0(\omega) = \beta(O) \cdot \exp\{-2\pi^2 \cdot \sigma_p^2 \cdot (\omega - m_p)^2\} - \varepsilon \cdot [\beta(O) \cdot \exp\{-2\pi^2 \cdot \sigma_p^2 \cdot (m_c - m_p)^2\} - b_{ias}] \cdot \exp\{-2\pi^2 \cdot \sigma_c^2 \cdot (\omega - m_c)^2\} \tag{A.3}$$

NOTE 2 $M_0(\omega)$ is expressed for each opponent colour space using different parameters (see Table A.1).

Table A.1 – Parameters for each axis of the opponent colour space

Opponent colour space	$\beta(O)$	$\gamma(\omega)$	m_p	σ_p	ε	m_c	σ_c	b_{ias}
w/k	$\beta_w(w_k)$	$\gamma_w(\omega)$	5,5	1/40	1	0	1/12	55
r/g	$\beta_r(r_g)$	$\gamma_r(\omega)$	1,5	1/70	0	NA	NA	NA
b/y	$\beta_b(b_y)$	$\gamma_b(\omega)$	1,5	1/45	1/4	7,5	1/20	0

NOTE For the colour space of r/g, “ m_c ”, “ σ_c ” and “ b_{ias} ” are not defined since $\varepsilon = 0$.

$\beta(O)$ is the maximum sensitivity coefficient defined in each opponent colour space. The values of w_k , r_g and b_y are the average of each value of the opponent colour space in the whole display screen.

$$\begin{aligned}\beta_w(w_k) &= 0,003\,626\,6\,w_k^3 - 0,428\,34\,w_k^2 + 17,342\,w_k - 50,764 \\ \beta_r(r_g) &= -0,075\,70\,r_g^2 + 8,731\,r_g - 1,839 \\ \beta_b(b_y) &= 0,000\,777\,26\,b_y^3 - 0,099\,832\,b_y^2 + 5,090\,7\,b_y + 1,3\end{aligned}\tag{A.4}$$

$\gamma(\omega)$ is the correction factor of the spatial frequency characteristics of the 45° direction. $\gamma(\omega)$ is expressed by a different formula for each opponent colour space:

$$\begin{aligned}\gamma_w(\omega) &= 0,003\,100\,\omega^2 - 0,106\,80\,\omega + 1,396; \\ \gamma_r(\omega) &= 0,001\,531\,\omega^2 - 0,061\,49\,\omega + 1,140; \\ \gamma_b(\omega) &= 0,001\,919\,\omega^2 - 0,064\,27\,\omega + 1,090.\end{aligned}\tag{A.5}$$

Therefore, $M_{\text{eye}}(u, v)$ is calculated for each opponent colour space as shown in Figure 7. Each of the opponent colour data was convolved with the visual spatial sensitivity function calculated using formulae (A.1) to (A.5). It is necessary to match a unit of the visual spatial sensitivity function filter to that of the Fourier transformed data. Because the measured image data does not have a unit such as length and angle on real space, the unit of the Fourier transformed data is “cycle per CCD pixel”. To make the Fourier transformed data have the same unit as the CSF filter, “ G_F ” is a useful factor to transform the unit (see 5.3.2.2).

$$G_F = H_R \times 2 \times V_D \times \tan(0,5) / W_L \text{ [CCD pixel/degree]}\tag{A.6}$$

where

G_F is the geometric factor relating the measured screen image with the real-space information

H_R is the horizontal pixel number of the measured screen image (CCD pixel)

V_D is the viewing distance (in mm)

W_L is wide length of Display screen (in mm)

The two-dimensional CSF model of the human eye is one of the useful characteristics for converting a measured image with an apparatus to a recognized image by the human visual system. Figure A.3 shows two examples. These examples show that some visual illusion is computable by adapting the two-dimensional CSF filters.

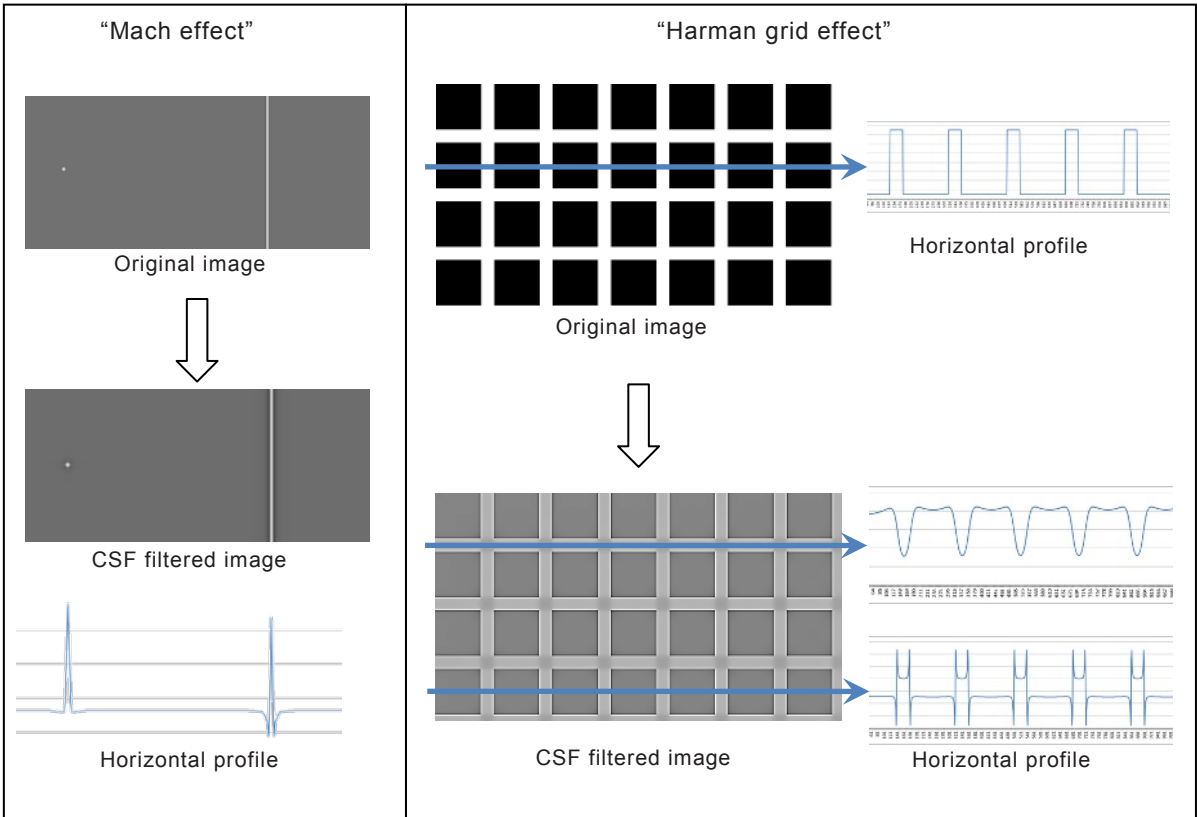

IEC

Figure A.3 – Examples of the convolution of a two-dimensional CSF filter for illusion

Annex B
(informative)









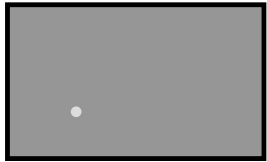

Type of mura

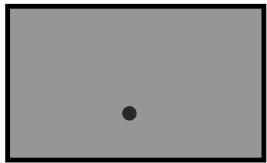
B.1 General

Mura could be classified depending on its form and/or causes. It is useful to classify mura for defect analysis. Various types of mura classification, including a specific cause for LCDs, were shown by Mr. Kai Chieh Chang in the meeting of IEC TC 110 in 2009. The classification of mura is shown in Clause B.2.

B.2 Classification of mura

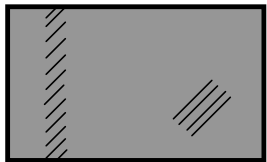
The classification of mura by forms and/or causes, including a cause peculiar to LCDs, is shown in Figure B.1.

Classification	Appearance	Classification	Appearance
Bright spot		White spot	
Spacer cluster		Black spot	
Dark spot		V-line	
Backlight white spot		H-line	
Backlight dust black spot		Rubbing mura	
Polarizer white spot		Backlight scratch	











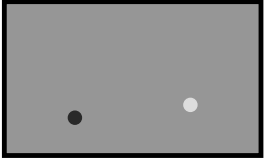

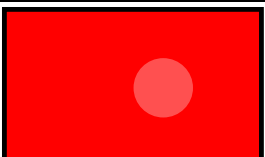

Classification	Appearance	Classification	Appearance
Polarizer black / white spot		Polarizer scratch	
Cell dust white spot		Backlight leakage	
H-band		Fill port mura	
V-band		CF mura	
File waving		Gap mura	
Shot mura		Bubble mura	
Frame mura		Gravity mura	
Cell light leakage		V-line cluster	
Around mura		Cloud mura	
Classification	Appearance	Classification	Appearance
Butterfly mura			

Figure B.1 – Classification of mura by forms and/or causes

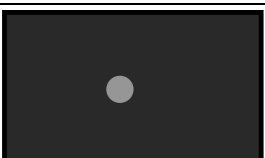
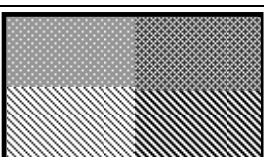
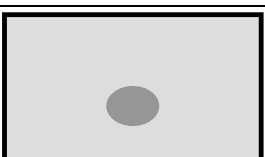
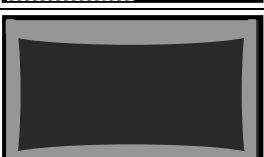
Annex C (informative)

Use case of a mura evaluation value

C.1 General

The ITU-R five-grade impairment scale is well known as a method for subjective assessment of image quality. The ITU-R five-grade visual inspection class is often used for mura evaluation. Therefore, knowing the relation between the mura evaluation value and the ITU-R five-grade visual inspection class is useful for the assessment of a mura quality level.

C.2 Example of a use case of a mura evaluation value

An example of a use case of a mura evaluation value is shown in Table C.1, and an example of subjects to evaluate is shown in Table C.2.

Table C.1 – Example of a use case of a mura evaluation value

ITU-R five-class visual inspection	Case 1	Case 2	Case 3
5	0 to 5	0 to 3	0 to 1
4	5 to 10	3 to 6	1 to 2
3	10 to 15	6 to 9	2 to 3
2	15 to 20	9 to 12	3 to 4
1	20 to 25	12 to 15	4 to 5

Table C.2 – Example of subjects to evaluate

Subject (device)	Signal input level
TV	20 %
	50 %
	100 %
Monitor	20 %
	50 %
	100 %
Monitor for medical	20 %
	50 %
	100 %

Annex D (informative)

Various mura measurement methods

D.1 General

Various measurement methods for luminance mura and colour mura have been used in various countries. However, there are hardly any methods that can be suggested for standardization. In this document, a mura measurement method using a 2D colorimeter is introduced, with the exception of the legacy method such as nine-point measurement.

D.2 Comparison of mura evaluation standards

The comparison chart of a mura measurement method using a 2D colorimeter is shown in Table D.1.

In IDMS the contrast sensitivity function (CSF) is applied to the human visual system. However, there are few descriptions of colour mura such as the following, “Color non-uniformities can optionally be measured by applying an appropriate CSF to chromaticity data and calculating the same defects.” [3]

As in IDMS, SEMI D31-0213 does not support mura, including luminance and colour mura simultaneously. The scope of SEMI D31-0213 is only about the luminance mura.[4] The threshold value is necessary to extract mura objects applying D31-0213, however, there is no description in the standard document of how to extract the mura area. Therefore the extract value cannot become common, because it is up to the user to define the threshold value.

The second column in Table D.1 is the method used in this document. It is suitable to the human visual system and has a high accuracy and availability.

Table D.1 – Comparison chart of various mura measurement standards

Comparison items	IEC TC110	ICDM	SEMI
Project/document number	IEC TR 62977-3-2, Edition1	IDMS version 1.03 Sec. 8.2: AREA UNIFORMITY	SEMI D31-0213
Lightness mura	available	available	available
Chroma mura	available	available	not available
Mura (lightness and chroma mura exist simultaneously)	available	not available	not available
Human vision factor: Contrast spatial frequency	supported	supported	not supported
Human vision factor: Helmholtz–Kohrausch effect	supported	not supported	not supported
Display size factor	supported	limited	not supported
Viewing distance factor	supported	limited	supported
Concept, common	available	available	available
Accuracy with actual sample	available	not available	not available
Availability	available	limited	limited

Bibliography

- [1] IEC 62341-6-1:2009, *Organic light emitting diode (OLED) displays – Part 6-1: Measuring methods of optical and electro-optical parameters*
 - [2] CIE Publication 15 (2004), *Colorimetry*
 - [3] ICDM Information Display Measurement Standard (IDMS) version 1.03:Sec.8.2 and A4.2.1
 - [4] SEMI D31-0213, *Definition of Measurement Index (Semu) for Luminance Mura in FPD Image Quality Inspection*
 - [5] K.Nagamine, S.Tomioka, T.Tamura, and Y.Shimpuku, *A Quantitative Evaluation Method for Color Uniformity of a Display Screen Based on Human Perceptions*. Proc. 31st IDRC EuroDisplay 2011: session 10.3
 - [6] K.Nagamine, S.Tomioka, T.Tamura, and Y.Shimpuku, *A Quantitative Evaluation Method for Luminance and Color Uniformity of a Display Screen Based on Human Perceptions*. IEICE TRANS. ELECTRON., Vol.E95-C, No.11 Nov.2012: p1699-1706
 - [7] K.Nagamine and S.Tomioka, *A Quantitative Mura Evaluation Method that Depends on Viewing Distance*. Proc. 19th International Display Workshops, Kyoto, 2012: p1975-1976
 - [8] S.Hasegawa, S.Tomioka and K.Nagamine, *General FPD Mura Index under the IEC Measurement Standard*. Proc. 21th International Display Workshops, Niigata, 2014: p949-952
 - [9] X.Zhang and B.A.Wandell, *A Spatila Extension of CIELAB for Digital Color Image Reproduction*. Journal of Society Information Display, 1997.5(1): p61-63
 - [10] Y.Miyake, T.Ishihara, K.Ohishi, and N.Tsumura, *Measurement and Modeling for the Two Dimensional MTF of Human Eye and Its Application for Digital Color Reproduction*. Proc. IS&T and SID Ninth Color Imaging Conference, 2001: p153-157
 - [11] Y.Miyake and K.Miyata, *Evaluation of multispectral imaging*, COLOUR IMAGE SCIENCE Exploiting Digital Media, 2002: p77-98
 - [12] T.Ishihara, K.Ohishi, N.Tsumura and Y.Miyake, *Dependence of Directivity in Spatial Frequency Response of Human Eye*. Journal of The Society of Photographic Science and Technology of Japan, Vol. 65, No. 2, 2002: p121-133
 - [13] Recommendation 500-13, *"Methodology for the Subjective Assessment of the Quality of Television Pictures"*, ITU-R Recommendations, 2012
 - [14] CIE 114-1994, *CIE Collection in Photometry and Radiometry*
-

